

1. Suppose you throw 10 darts randomly at the dart board below and that all darts hit the board. Find the probability of landing in the shaded region.

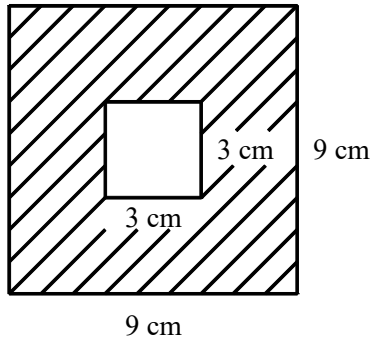

- [A] 9 [B] $\frac{1}{9}$ [C] $\frac{9}{8}$ [D] $\frac{8}{9}$

2. Compare the quantity in Column A with the quantity in Column B. Here are two different dart boards, A and B. The dashed line shows the target region of each. One dart is thrown at random at each board. What is the probability that the dart will land in the target area?

Column A

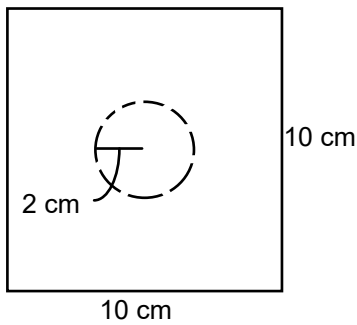

Column B

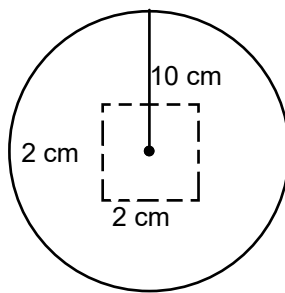

- [A] The quantity in Column A is greater. [B] The quantity in Column B is greater.
 [C] The quantities are equal.
 [D] The relationship cannot be determined on the basis of the information supplied.

3. You have 10 dowels that range in circumference from $\frac{1}{2}$ in. to 5 in. with $\frac{1}{2}$ in. increments. If you choose a dowel at random, what is the probability that it will go through a hole in a piece of wood that is 1 in. in diameter?

- [A] 1 [B] $\frac{3}{5}$ [C] 0 [D] $\frac{1}{2}$ [E] not given

4. Compare the quantity in Column A with the quantity in Column B.

Column A
the probability of
landing on red:

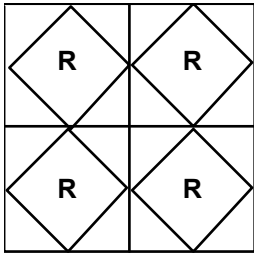

Column B
the probability of
landing on red:

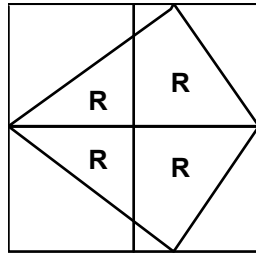

- [A] The quantity in Column A is greater. [B] The quantity in Column B is greater.
[C] The two quantities are equal.
[D] The relationship cannot be determined on the basis of the information supplied.

5. Two concentric circles have radii of 12 and 26 cm. Find the probability that a point chosen at random from the circles is located outside the smaller circle and inside the larger one.

- [A] 4.7% [B] 92.4% [C] 21.3% [D] 78.7%

6. A box is packed with six unopened cans. You win a prize if you drop a ball and it falls between the cans into the box. Assume that if a ball hits a can, it does not fall into the box. What is the probability you will win a prize? Would your chances improve with more or fewer cans packed in the same way?

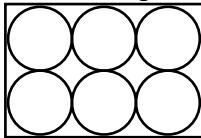

7. If a point is selected at random, what is the probability that it will lie within the shaded rectangular region rather than the unshaded rectangular region?

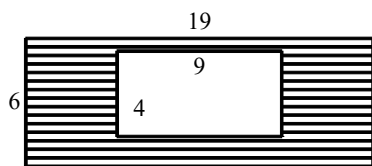

8. A wishing well is 6 ft in diameter. Centered at the bottom of the well is a bucket that is 1 ft in diameter. If you drop a coin in the well without looking, what is the probability it will land in the bucket?

Geometry Practice G.MG.A.3: Geometric Probability
www.jmap.org

[1] D

[2] A

[3] B

[4] C

[5] D

[6] 0.215; no, the probability remains the same
for any similar configuration of cans

[7] $\frac{13}{19}$

[8] $\frac{1}{36}$