

FOR TEACHERS ONLY

SG

INSTRUCTIONS FOR RATING SOLID GEOMETRY

Wednesday, August 25, 1954—12 m. to 3 p. m., only

Use only *red* ink or pencil in rating Regents papers. Do not attempt to *correct* the pupil's work by making insertions or changes of any kind. Use check marks to indicate pupil errors.

Unless otherwise specified, mathematically correct variations in the answers will be allowed. Units need not be given when the wording of the questions allows such omissions.

Part I

Allow $2\frac{1}{2}$ credits for each correct answer; allow no partial credit. For questions 14–16, allow credit if the pupil has written the correct expression instead of the letter *a*, *b* or *c*.

- (1) $\sqrt{194}$
- (2) 216
- (3) $4\pi r^2$
- (4) 3
- (5) 9:4
- (6) 960
- (7) 80
- (8) 25
- (9) 2.2
- (10) 36π

- (11) 30π
- (12) 6π
- (13) 12π
- (14) *c*
- (15) *a*
- (16) *c*
- (17) true
- (18) true
- (19) false
- (20) true

The University of the State of New York

322ND HIGH SCHOOL EXAMINATION

SOLID GEOMETRY

Wednesday, August 25, 1954 — 12 m. to 3 p. m., only

Instructions

Part I is to be done first and the maximum time allowed for it is one and one half hours. At the end of that time, this part of the examination must be detached and will be collected by the teacher. If you finish part I before the signal to stop is given, you may begin part II.

Write at top of first page of answer paper to parts II and III (a) names of schools where you have studied, (b) number of weeks and recitations a week in solid geometry previous to entering summer high school, (c) number of recitations in this subject attended in summer high school of 1954 or number and length in minutes of lessons taken in the summer of 1954 under a tutor licensed in the subject and supervised by the principal of the school you last attended, (d) author of textbook used.

The minimum time requirement is four or five recitations a week for half a school year. The summer school session will be considered the equivalent of one semester's work during the regular session (four or five recitations a week for half a school year).

For those pupils who have met the time requirement the minimum passing mark is 65 credits; for all others 75 credits.

For admission to this examination attendance on at least 30 recitations in this subject in a registered summer high school in 1954 or an equivalent program of tutoring approved in advance by the Department is required.

Part II

Answer two questions from part II.

- 21 Prove that two lines perpendicular to the same plane are parallel. [10]
- 22 Prove that the sum of the angles of a spherical triangle is greater than 180° and less than 540° . [10]
- 23 Given any three elements, e_1 , e_2 and e_3 , of a cone. Prove that if a plane divides e_1 , e_2 and e_3 proportionally, the plane is parallel to the base of the cone. [10]
- 24 Given horizontal plane H and point P which is 3 inches above H .
- a Describe *fully* the locus of points
- (1) at a distance of 5 inches from H [2]
 - (2) at a distance of r inches from P [2]
- b Tell whether *each* of the following statements is true or false:
- (1) The locus of points satisfying *both* conditions given in a is a point if $r = 2$. [2]
 - (2) The locus of points satisfying *both* conditions given in a consists of a circle and a point if $r = 3$. [2]
 - (3) The locus of points satisfying *both* conditions given in a consists of two circles if r has any value greater than 8. [2]

SOLID GEOMETRY

Part III

Answer three questions from part III. All work, including computation, should be shown.

25 The top and bottom parts of the fuel storage tank shown in the diagram are half cylinders; the middle part is a rectangular parallelepiped. The tank is 28 inches wide, 44 inches high and 60 inches long. Find the capacity of the tank to the nearest gallon. [1 gallon = 231 cubic inches; use $\pi = \frac{22}{7}$.] [10]

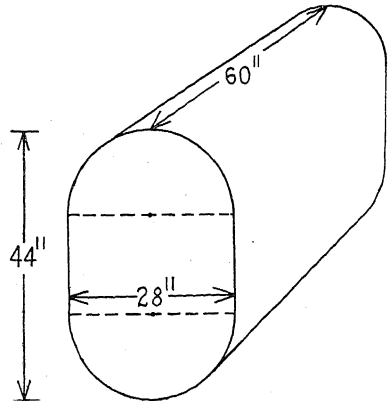

26 A grain chute is in the shape of two frustums of cones of revolution, as shown in the diagram. The radii of the bases are 3 feet, 6 feet and 9 feet, and the altitudes are 14 feet and 7 feet. Find the volume of the chute in cubic feet. [Use $\pi = \frac{22}{7}$; the formula for the volume of a frustum is $V = \frac{1}{3} \pi h (r_1^2 + r_2^2 + r_1 r_2)$] [10]

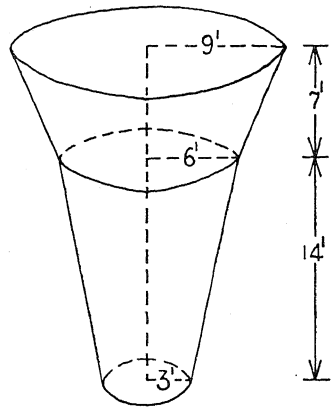

27 ABC is a spherical triangle with side AB equal to side AC and angle A equal to 30° . The area of the triangle is one third the area of the lune formed by extending the equal sides of the triangle.

a Find a base angle of the triangle. [6]

b If the perimeter of the lune is 12π inches, find in square inches the area of the triangle. [Answer may be left in terms of π .] [4]

28 The edge of a cube is e .

a Express e in terms of the volume, V , of the cube. [1]

b Express the lateral area, S , of the cube in terms of e . [1]

c Express S in terms of V . [3]

d If $V = 34.5$ cubic inches, find S to the nearest square inch. [5]

SOLID GEOMETRY

Fill in the following lines:

Name of pupil.....Name of school.....

Part I

Answer all questions in part I. Each correct answer will receive $2\frac{1}{2}$ credits. No partial credit will be allowed.

1 A rectangular parallelepiped has the dimensions 7, 8 and 9. Find its diagonal. [Answer may be left in radical form.] 1.....

2 A cube has a total area of 216 square inches. Find its volume in cubic inches. 2.....

3 A cylinder of revolution has its altitude equal to the radius, r , of its base. Express the total area of the cylinder in terms of r . 3.....

4 The volume of a circular cylinder is 63π and its altitude is 7. Find the radius of its base. 4.....

5 The volumes of two similar prisms are in the ratio 27 to 8. Find the ratio of the area of the base of the larger prism to that of the smaller. 5.....

6 A regular square pyramid has base edges of 24 and a slant height of 13. Find its volume. 6.....

7 The slant height of a frustum of a regular pyramid is 8 and the perimeters of its bases are 5 and 15. Find the lateral area of the frustum. 7.....

8 A cone has a base of 36 square inches and an altitude of 12 inches. Find the area in square inches of a section made by a plane parallel to the base and 2 inches from the base. 8.....

9 An element of a cone of revolution has a length of 7.0 inches and is inclined 18° to the base. Find the altitude of the cone to the nearest tenth of an inch. 9.....

10 The diameter of a sphere is 6. Find its volume. [Answer may be left in terms of π .] 10.....

11 A zone of a sphere has an altitude of 4 and an area of 24π . Find the area of a zone of the same sphere that has an altitude of 5. [Answer may be left in terms of π .] 11.....

12 A lune is drawn on a sphere whose area is 144π . If the angle of the lune is 15° , find the area of the lune. [Answer may be left in terms of π .] 12.....

13 A spherical triangle drawn on a sphere whose radius is 4 inches has angles of 80° , 100° and 135° . Find the area of the triangle in square inches. [Answer may be left in terms of π .] 13.....

Directions (14–16): Indicate the correct completion for each statement by writing on the line at the right the letter a , b or c .

14 If two face angles of a trihedral angle are the acute angles x and $2x$, the third face angle may be (a) $360^\circ - 3x$ (b) x (c) $2x$ 14.....

15 The number of points that are equidistant from all points on a given circle and also equidistant from two parallel planes that are oblique to the plane of the circle is (a) one (b) two (c) unlimited 15.....

SOLID GEOMETRY

16 If the radius of the lower base of a frustum of a cone of revolution is 5 inches and the radius of the upper base is one inch, the slant height must be (a) less than 4 inches (b) equal to 4 inches (c) greater than 4 inches

16.....

Directions (17–20): For each of the following, if the statement is *always* true, write the word *true* on the line at the right; if it is *not always* true, write the word *false*.

17 If line l is the edge of a dihedral angle whose plane angle is ABC , then AB is perpendicular to l .

17.....

18 If two planes are perpendicular, every line in one plane perpendicular to their intersection is also perpendicular to the other plane.

18.....

19 If two sides of a spherical triangle are quadrants, the spherical triangle is the polar triangle of itself.

19.....

20 If two planes are parallel, any line in one of the planes is parallel to more than one line in the other.

20.....