

1. 060301a, P.I. 7.N.6  
The number  $8.375 \times 10^{-3}$  is equivalent to  
[A] 0.0008375      [B] 0.08375  
[C] 8,375      [D] 0.008375

2. 060302a, P.I. A.G.1  
The accompanying diagram shows a square with side  $y$  inside a square with side  $x$ .

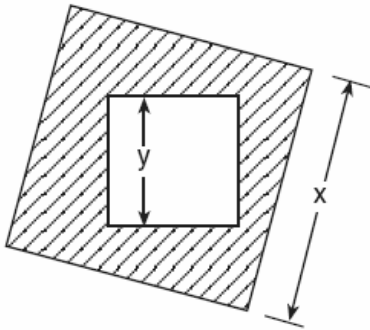

Which expression represents the area of the shaded region?

- [A]  $x^2 - y^2$       [B]  $y^2$   
[C]  $x^2$       [D]  $y^2 - x^2$
3. 060303a, P.I. 7.N.2  
Which expression represents an irrational number?  
[A]  $\sqrt{2}$     [B] 0    [C] 0.17    [D]  $\frac{1}{2}$
4. 060304a  
Which shape does *not* have rotational symmetry?  
[A] square    [B] circle  
[C] regular pentagon    [D] trapezoid

5. 060305a, P.I. A.S.23  
Bob and Laquisha have volunteered to serve on the Junior Prom Committee. The names of twenty volunteers, including Bob and Laquisha, are put into a bowl. If two names are randomly drawn from the bowl without replacement, what is the probability that Bob's name will be drawn first and Laquisha's name will be drawn second?

- [A]  $\frac{1}{20} \cdot \frac{1}{20}$       [B]  $\frac{2}{20}$   
[C]  $\frac{2}{20!}$       [D]  $\frac{1}{20} \cdot \frac{1}{19}$

6. 060306a, P.I. A.N.1  
Tori computes the value of  $8 \times 95$  in her head by thinking  $8(100 - 5) = 8 \times 100 - 8 \times 5$ . Which number property is she using?

- [A] associative      [B] commutative  
[C] distributive      [D] closure

7. 060307a, P.I. G.G.45  
A triangle has sides whose lengths are 5, 12, and 13. A similar triangle could have sides with lengths of

- [A] 3, 4, and 15      [B] 7, 24, and 25  
[C] 6, 8, and 10      [D] 10, 24, and 26

8. 060308a, P.I. G.G.26  
Which statement is logically equivalent to "If it is Saturday, then I am not in school"?

- [A] If it is not Saturday, then I am in school.  
[B] If I am in school, then it is not Saturday.  
[C] If it is Saturday, then I am in school.  
[D] If I am not in school, then it is Saturday.

9. 060309a, P.I. G.G.54  
A translation moves  $P(3,5)$  to  $P'(6,1)$ . What are the coordinates of the image of point  $(-3,-5)$  under the same translation?  
[A]  $(-6,-9)$  [B]  $(-5,-3)$   
[C]  $(-6,-1)$  [D]  $(0,-9)$
10. 060310a, P.I. A.A.22  
If  $x + y = 9x + y$ , then  $x$  is equal to  
[A] 0 [B]  $\frac{1}{5}y$  [C] 8 [D]  $y$
11. 060311a, P.I. A.A.21  
Which number is in the solution set of the inequality  $5x + 3 > 38$ ?  
[A] 8 [B] 5 [C] 7 [D] 6
12. 060312a, P.I. A.A.12  
The expression  $3^2 \cdot 3^3 \cdot 3^4$  is equivalent to  
[A]  $3^{24}$  [B]  $27^9$  [C]  $27^{24}$  [D]  $3^9$
13. 060313a, P.I. A.A.27  
What is the solution set of the equation  $x^2 - 5x - 24 = 0$ ?  
[A]  $\{-3,8\}$  [B]  $\{3,8\}$   
[C]  $\{3,-8\}$  [D]  $\{-3,-8\}$
14. 060314a, P.I. 7.N.11  
If the expression  $3 - 4^2 + \frac{6}{2}$  is evaluated, what would be done *last*?  
[A] adding [B] squaring  
[C] subtracting [D] dividing
15. 060315a, P.I. A.N.1  
What is the additive inverse of  $\frac{2}{3}$ ?  
[A]  $\frac{1}{3}$  [B]  $\frac{3}{2}$  [C]  $-\frac{3}{2}$  [D]  $-\frac{2}{3}$
16. 060316a, P.I. A.N.3  
The sum of  $\sqrt{18}$  and  $\sqrt{72}$  is  
[A]  $3\sqrt{10}$  [B]  $\sqrt{90}$   
[C]  $9\sqrt{2}$  [D]  $6\sqrt{3}$
17. 060317a, P.I. G.G.26  
What is the inverse of the statement "If Julie works hard, then she succeeds"?  
[A] If Julie does not work hard, then she does not succeed.  
[B] If Julie succeeds, then she works hard.  
[C] If Julie works hard, then she does not succeed.  
[D] If Julie does not succeed, then she does not work hard.
18. 060318a, P.I. A.A.20  
If one factor of  $56x^4y^3 - 42x^2y^6$  is  $14x^2y^3$ , what is the other factor?  
[A]  $4x^2y - 3xy^3$  [B]  $4x^2 - 3y^2$   
[C]  $4x^2y - 3xy^2$  [D]  $4x^2 - 3y^3$
19. 060319a, P.I. A.A.15  
For which value of  $x$  is the expression  $\frac{3x-6}{x-4}$  undefined?  
[A] 0 [B] 2 [C] 4 [D] -4
20. 060320a, P.I. A2.S.11  
How many different five-member teams can be made from a group of eight students, if each student has an equal chance of being chosen?  
[A] 56 [B] 6,720 [C] 336 [D] 40

21. 060321a, P.I. 6.S.5  
The student scores on Mrs. Frederick's mathematics test are shown on the stem-and-leaf plot below.

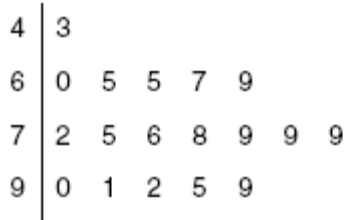

Key: 4 | 3 = 43 points

Find the median of these scores.

22. 060322a, P.I. G.G.58  
The lengths of the sides of two similar rectangular billboards are in the ratio 5:4. If 250 square feet of material is needed to cover the larger billboard, how much material, in square feet, is needed to cover the smaller billboard?
23. 060323a, P.I. A.A.22  
Solve for  $m$ :  $0.6m + 3 = 2m + 0.2$
24. 060324a, P.I. 8.A.12  
In the accompanying diagram, line  $m$  is parallel to line  $p$ , line  $t$  is a transversal,  $m\angle a = 3x + 12$ , and  $m\angle b = 2x + 13$ . Find the value of  $x$ .

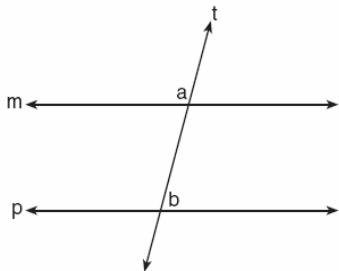

25. 060325a  
On the accompanying diagram of  $\triangle ABC$ , use a compass and a straightedge to construct a median from  $A$  to  $\overline{BC}$ .

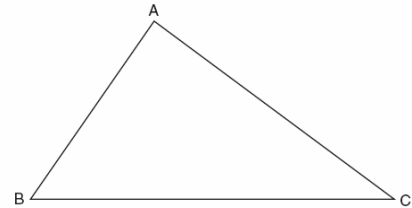

26. 060326a, P.I. A.A.7  
Seth has one less than twice the number of compact discs (CDs) that Jason has. Raoul has 53 more CDs than Jason has. If Seth gives Jason 25 CDs, Seth and Jason will have the same number of CDs. How many CDs did *each* of the three boys have to begin with?
27. 060327a  
Tina's preschool has a set of cardboard building blocks, each of which measures 9 inches by 9 inches by 4 inches. How many of these blocks will Tina need to build a wall 4 inches thick, 3 feet high, and 12 feet long?
28. 060328a, P.I. A.N.5  
In a town election, candidates  $A$  and  $B$  were running for mayor. There were 30,500 people eligible to vote, and  $\frac{3}{4}$  of them actually voted. Candidate  $B$  received  $\frac{1}{3}$  of the votes cast. How many people voted for candidate  $B$ ? What percent of the votes cast, to the nearest tenth of a percent, did candidate  $A$  receive?

29. 060329a, P.I. A.N.8

A certain state is considering changing the arrangement of letters and numbers on its license plates. The two options the state is considering are:

Option 1: three letters followed by a four-digit number with repetition of both letters and digits allowed

Option 2: four letters followed by a three-digit number without repetition of either letters or digits

[Zero may be chosen as the first digit of the number in either option.]

Which option will enable the state to issue more license plates? How many *more* different license plates will that option yield?

30. 060330a

To get from his high school to his home, Jamal travels 5.0 miles east and then 4.0 miles north. When Sheila goes to her home from the same high school, she travels 8.0 miles east and 2.0 miles south. What is the measure of the shortest distance, to the *nearest tenth of a mile*, between Jamal's home and Sheila's home? [The use of the accompanying grid is optional.]

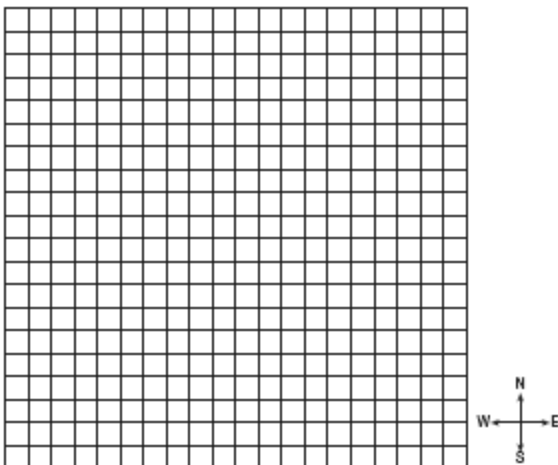

31. 060331a

Deborah built a box by cutting 3-inch squares from the corners of a rectangular sheet of cardboard, as shown in the accompanying diagram, and then folding the sides up. The volume of the box is 150 cubic inches, and the longer side of the box is 5 inches more than the shorter side. Find the number of inches in the shorter side of the *original* sheet of cardboard.

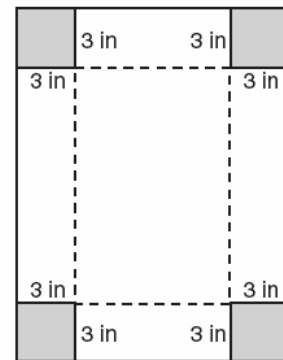

32. 060332a, P.I. G.G.22

A triangular park is formed by the intersection of three streets, Bridge Street, Harbor Place, and College Avenue, as shown in the accompanying diagram. A walkway parallel to Harbor Place goes through the park. A time capsule has been buried in the park in a location that is equidistant from Bridge Street and College Avenue and 5 yards from the walkway. Indicate on the diagram with an **X** *each* possible location where the time capsule could be buried.

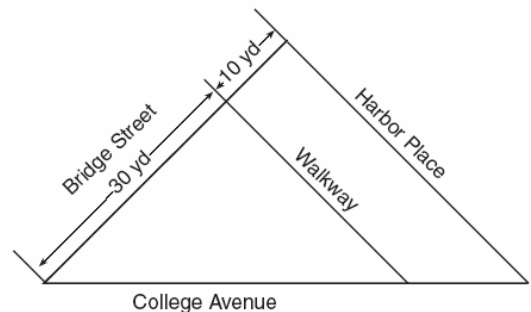

33. 060333a, P.I. A.G.4

An architect is designing a museum entranceway in the shape of a parabolic arch represented by the equation  $y = -x^2 + 20x$ , where  $0 \leq x \leq 20$  and all dimensions are expressed in feet. On the accompanying set of axes, sketch a graph of the arch and determine its maximum height, in feet.

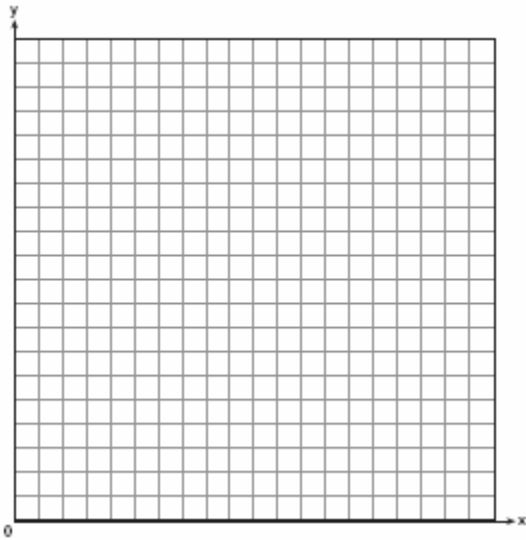

35. 060335a, P.I. A.A.7

The senior class is sponsoring a dance. The cost of a student disk jockey is \$40, and tickets sell for \$2 each. Write a linear equation and, on the accompanying grid, graph the equation to represent the relationship between the number of tickets sold and the profit from the dance. Then find how many tickets must be sold to break even.

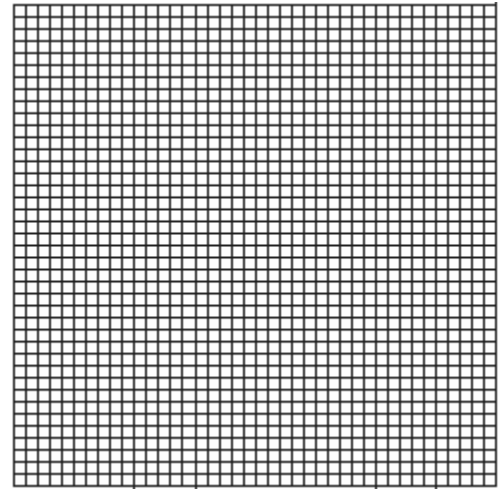

34. 060334a, G.G.48

A straw is placed into a rectangular box that is 3 inches by 4 inches by 8 inches, as shown in the accompanying diagram. If the straw fits exactly into the box diagonally from the bottom left front corner to the top right back corner, how long is the straw, to the *nearest tenth of an inch*?

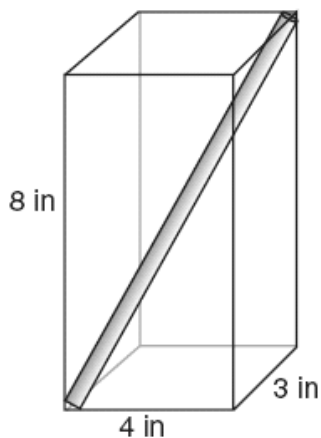

- [1]   D
- [2]   A
- [3]   A
- [4]   D
- [5]   D
- [6]   C
- [7]   D
- [8]   B
- [9]   D
- [10]  A
- [11]  A
- [12]  D
- [13]  A
- [14]  A
- [15]  D
- [16]  C
- [17]  A
- [18]  D
- [19]  C
- [20]  A

[2] 77, and appropriate work is shown, such as  $(76 + 78) \div 2$ .

[1] 76 and 78 are identified.

or [1] 77, but no work is shown.

[0] A zero response is completely incorrect, irrelevant, or incoherent or is a correct response that was obtained by an obviously

[21] incorrect procedure.

[2] 160, and appropriate work is shown, such as the proportion  $\frac{25}{16} = \frac{250}{x}$ .

[1] Appropriate work is shown, but one computational error or one conceptual error is made, such as  $\frac{5}{4} = \frac{250}{x}$ .

or [1] 160, but no work is shown.

[0] A zero response is completely incorrect, irrelevant, or incoherent or is a correct response that was obtained by an obviously

[22] incorrect procedure.

[2] 2, and appropriate work is shown.

[1] Appropriate work is shown, but one computational error or one conceptual error is made.

or [1] 2, but no work is shown.

[0] A zero response is completely incorrect, irrelevant, or incoherent or is a correct response that was obtained by an obviously

[23] incorrect procedure.

[2] 31, and appropriate work is shown, such as  $5x + 25 = 180$ .

[1] Appropriate work is shown, but one computational error is made.

or [1] Appropriate work is shown, but one conceptual error is made, such as setting the given angles equal to each other.

or [1] A correct equation is written, but no further correct work is shown.

or [1] 31, but no work is shown.

[0] A zero response is completely incorrect, irrelevant, or incoherent or is a correct response that was obtained by an obviously

[24] incorrect procedure.

- [2] A correct construction is drawn to find the midpoint of  $\overline{BC}$ , showing both sets of arcs and a line connecting A with the midpoint.
- [1] A correct construction is drawn to find the midpoint of  $\overline{BC}$ , but the median is not drawn.
- or [1] The construction is appropriate, but a compass and a straightedge are not used.
- [0] No construction arcs are shown.
- or [0] A zero response is completely incorrect, irrelevant, or incoherent or is a correct response that was obtained by an obviously incorrect procedure.
- 
- [25] [3] Seth had 101, Jason had 51, and Raoul had 104, and appropriate work is shown, such as  $x + 25 = (2x - 1) - 25$  or trial and error with at least three trials and appropriate checks.
- [2] Appropriate work is shown, but one computational error is made.
- or [2] 101, 51, and 104, and appropriate work is shown, but the solutions are not labeled or are labeled incorrectly.
- or [2] A correct equation is solved, but the number of CDs for only one boy is found.
- or [2] The trial-and-error method is used to find a correct solution, but only two trials and appropriate checks are shown.
- [1] Appropriate work is shown, but more than one computational error is made.
- or [1] Appropriate work is shown, but one conceptual error is made, but an appropriate number of CDs is found for each boy.
- or [1] A correct equation is written, but no further correct work is shown.
- or [1] Seth had 101, Jason had 51, and Raoul had 104, but no work or only one trial with an appropriate check is shown.
- [0] Seth had 101 or Jason had 51 or Raoul had 104, but no work is shown.
- or [0] 101, 51, and 104, but no work is shown and the solutions are not labeled or are labeled incorrectly.
- or [0] A zero response is completely incorrect, irrelevant, or incoherent or is a correct response that was obtained by an obviously incorrect procedure.
- 
- [26]

- [3] 64, and appropriate work is shown, such as calculating  $\frac{(36 \times 144)}{(9 \times 9)}$  or drawing a labeled diagram.
- [2] Appropriate work is shown, but one computational error is made.
- [1] Appropriate work is shown, but more than one computational error is made.
- or [1] Appropriate work is shown, but one conceptual error is made.
- or [1] 64, but no work is shown.
- [0] A zero response is completely incorrect, irrelevant, or incoherent or is a correct response that was obtained by an obviously incorrect procedure.
- 
- [27] [3] 7,625 and 66.7%, and appropriate work is shown.
- [2] Appropriate work is shown, but one computational error is made.
- or [2] Only the number of votes for candidate B is found correctly, but appropriate work is shown.
- [1] Appropriate work is shown, but more than one computational error is made.
- or [1] Appropriate work is shown, but one conceptual error is made.
- or [1] The percent of votes cast for candidate A is found correctly, but no further correct work is shown.
- or [1] 7,625 and 66.7%, but no work is shown.
- [0] 7,625 or 66.7%, but no work is shown.
- or [0] A zero response is completely incorrect, irrelevant, or incoherent or is a correct response that was obtained by an obviously incorrect procedure.
- 
- [28]

- [3] Option 2 will yield 82,576,000 more possibilities, and appropriate work is shown, such as  $26^3 \cdot 10^4$  and  ${}_{26}P_4 \cdot {}_{10}P_3$ .
- [2] Appropriate work is shown, but one computational error is made, but the appropriate option is identified.  
or [2] The correct numbers of arrangements are found for both Option 1 and Option 2, but the question of which option will yield more arrangements is not answered or is answered incorrectly.
- [1] Appropriate work is shown, but more than one computational error is made, but the appropriate option is identified.  
or [1] Appropriate work is shown, but one conceptual error is made, but the appropriate option is identified.  
or [1] Either Option 1 or Option 2 is found correctly, but no further correct work is shown.  
or [1] Option 2 will yield 82,576,000 more possibilities, but no work is shown.  
[0] Option 2, but no work or inappropriate work is shown.  
or [0] A zero response is completely incorrect, irrelevant, or incoherent or is a correct response that was obtained by an obviously incorrect procedure.
- [29] 

---
- [3] 6.7, and appropriate work is shown, such as using the distance formula.
- [2] Appropriate work is shown, but one computational or rounding or graphing error is made or the answer is left in radical form.
- [1] Appropriate work is shown, but more than one computational or rounding or graphing error is made.  
or [1] Only an appropriate diagram or graph is shown.  
or [1] The horizontal distance is determined to be 3, and the vertical distance is determined to be 6, but the shortest distance is not found.  
or [1] 6.7, but no work is shown.  
[0] A zero response is completely incorrect, irrelevant, or incoherent or is a correct response that was obtained by an obviously incorrect procedure.
- [30] 

---
- [4] 11, and appropriate work is shown, such as solving the quadratic equation  $3x(x+5) = 150$  or trial and error with at least three trials and appropriate checks.
- [3] Appropriate work is shown, but one computational error is made.  
or [3] Appropriate work is shown to determine that 5 is the shorter side of the box, but the shorter side of the original sheet is not found or is found incorrectly.  
or [3] An incorrect quadratic equation of equal difficulty is solved appropriately, and an appropriate shorter side of the original sheet is found.
- [2] Appropriate work is shown, but more than one computational error is made.  
or [2] Appropriate work is shown, but one conceptual error is made.  
or [2] An incorrect quadratic equation of equal difficulty is solved appropriately, but the shorter side of the original sheet is not found.  
or [2] A correct quadratic equation is set equal to zero, but no further correct work is shown.  
or [2] The trial-and-error method is used to find a correct solution, but only two trials and appropriate checks are shown.
- [1] Appropriate work is shown, but one conceptual error and one computational error are made.  
or [1] One conceptual error is made in finding the shorter side of the box, and the corresponding shorter side of the original sheet is not found or is found incorrectly.  
or [1] A correct quadratic equation is written, but it is not set equal to zero, and no further correct work is shown.  
or [1] 11, but no work or only one trial with an appropriate check is shown.  
[0] A zero response is completely incorrect, irrelevant, or incoherent or is a correct response that was obtained by an obviously incorrect procedure.
- [31] 

---



- [4] Two Xs are indicated at the intersections of the angle bisector and the parallel lines in the correct sketch of the loci.
- [3] All loci are drawn correctly, but no Xs are drawn to indicate the locations, or only one X is drawn.
- or [3] The angle bisector is drawn correctly, but only one line is drawn parallel to the walkway, but an X is indicated appropriately.
- [2] Only one correct locus is drawn, but Xs indicate the two appropriate locations of the intersection of the loci.
- [1] Xs are drawn in the correct locations, but no loci are shown.
- or [1] Only one correct locus is drawn, and no Xs are indicated.
- or [1] Both loci are drawn incorrectly, but Xs are drawn on the appropriate points of intersection.
- [0] A zero response is completely incorrect, irrelevant, or incoherent or is a correct response that was obtained by an obviously incorrect procedure.
- 

- [4] 100 and a correct parabolic arch is drawn, and appropriate work is shown, such as a table of values for the parabola or correctly labeled points.
- [3] 100 and a correct parabolic arch is drawn, but no table of values or labeled points are shown.
- or [3] 100 and a correct parabolic arch is drawn, and appropriate work is shown, but no scale or an incorrect scale is shown.
- or [3] A correct parabolic arch is drawn, but the maximum height is missing or is incorrect.
- [2] An incorrect parabolic arch is drawn, but an appropriate maximum height is found.
- or [2] A correct height is determined algebraically, but a parabolic arch is not drawn.
- or [2] 100 and an appropriate parabolic arch is drawn, but it is not drawn between  $0 \leq x \leq 20$ .
- [1] A correct parabolic arch is drawn, but no work is shown, such as a table of values or correctly labeled points, and the maximum height is missing or is incorrect.
- or [1] 100, but no work is shown and no parabolic arch is drawn.
- [0] A zero response is completely incorrect, irrelevant, or incoherent or is a correct response that was obtained by an obviously incorrect procedure.
-

- [4] 9.4, and appropriate work is shown, such as the use of the Pythagorean theorem.  
[3] Appropriate work is shown, but one computational or rounding error is made.  
[2] Appropriate work is shown, but more than one computational or rounding error is made.  
or [2] Appropriate work is shown, but one conceptual error is made.  
or [2] An incorrect diagonal of the base is found, but an appropriate solution is found.  
or [2] Only the diagonal of the base is found correctly, but appropriate work is shown, such as  $3^2 + 4^2 = d^2$  or use of 3–4–5 right triangles.  
[1] Appropriate work is shown, but one conceptual error and one computational or rounding error are made.  
or [1] The Pythagorean theorem is used to find the length of the straw, but the appropriate legs are not used.  
or [1] 9.4, but no work is shown.  
[0] A zero response is completely incorrect, irrelevant, or incoherent or is a correct response that was obtained by an obviously incorrect procedure.  
[34] 

---

- [4]  $y = 2x - 40$ , a correctly drawn graph with a slope of 2 and a y-intercept of -40, and 20, and appropriate work is shown.  
[3] Appropriate work is shown, but one computational or graphing error is made.  
or [3] The equation and graph are correct, but the breakeven point is missing or is incorrect.  
[2] Appropriate work is shown, but more than one computational or graphing error is made.  
or [2] An incorrect equation is written, but an appropriate graph is drawn, and an appropriate breakeven point is identified.  
[1] An incorrect equation is written, but an appropriate graph is drawn, but the breakeven point is missing or is incorrect.  
or [1] A correct equation is written, but the graph is incorrect, and the breakeven point is not identified.  
or [1]  $y = 2x - 40$  and 20, but no work is shown and no graph is drawn.  
[0] A zero response is completely incorrect, irrelevant, or incoherent or is a correct response that was obtained by an obviously incorrect procedure.  
[35] 

---