

The University of the State of New York
REGENTS HIGH SCHOOL EXAMINATION

MATHEMATICS A

Monday, January 27, 2003 — 1:15 to 4:15 p.m., only

Print Your Name:

Steve Watson

Print Your School's Name:

IHS @ PH

Print your name and the name of your school in the boxes above. Then turn to the last page of this booklet, which is the answer sheet for Part I. Fold the last page along the perforations and, slowly and carefully, tear off the answer sheet. Then fill in the heading of your answer sheet.

Scrap paper is not permitted for any part of this examination, but you may use the blank spaces in this booklet as scrap paper. A perforated sheet of scrap graph paper is provided at the end of this booklet for any question for which graphing may be helpful but is not required. Any work done on this sheet of scrap graph paper will *not* be scored. All work should be written in pen, except graphs and drawings, which should be done in pencil.

This examination has four parts, with a total of 35 questions. You must answer all questions in this examination. Write your answers to the Part I multiple-choice questions on the separate answer sheet. Write your answers to the questions in Parts II, III, and IV directly in this booklet. Clearly indicate the necessary steps, including appropriate formula substitutions, diagrams, graphs, charts, etc.

When you have completed the examination, you must sign the statement printed at the end of the answer sheet, indicating that you had no unlawful knowledge of the questions or answers prior to the examination and that you have neither given nor received assistance in answering any of the questions during the examination. Your answer sheet cannot be accepted if you fail to sign this declaration.

Notice. . .

A minimum of a scientific calculator, a straightedge (ruler), and a compass must be available for your use while taking this examination.

DO NOT OPEN THIS EXAMINATION BOOKLET UNTIL THE SIGNAL IS GIVEN.

Part I

Answer all questions in this part. Each correct answer will receive 2 credits. No partial credit will be allowed. Record your answers in the spaces provided on the separate answer sheet. [40]

1 The accompanying diagram shows a box-and-whisker plot of student test scores on last year's Mathematics A midterm examination.

Use this space for computations.

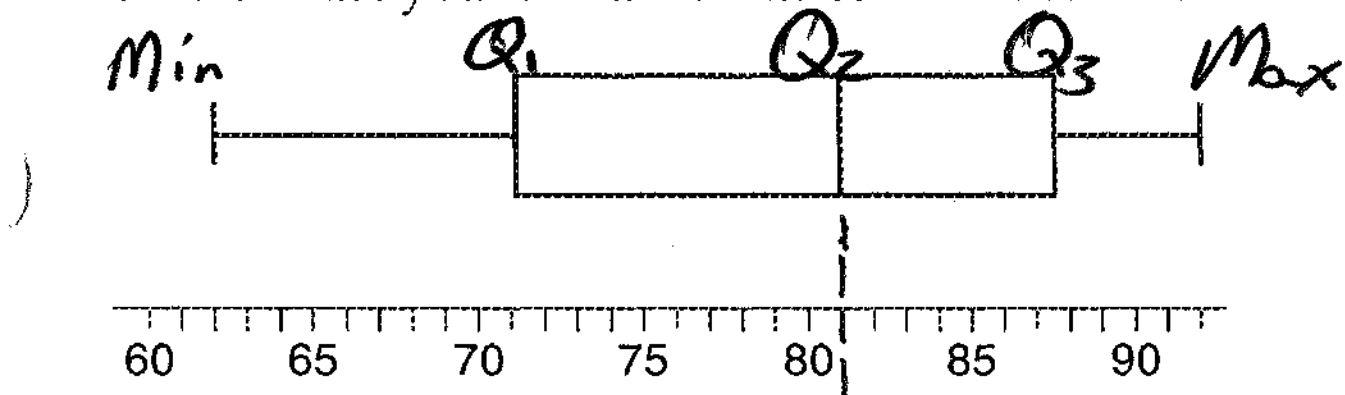

$Q_3 = \text{Median}$

What is the median score?

- (1) 62
- (2) 71
- (3) 81
- (4) 92

2 Triangle $A'B'C'$ is the image of $\triangle ABC$ under a dilation such that $A'B' = 3AB$. Triangles ABC and $A'B'C'$ are

Dilations are always similar.

- (1) congruent but not similar
- (2) similar but not congruent
- (3) both congruent and similar
- (4) neither congruent nor similar

3 What is the inverse of the statement "If Mike did his homework, then he will pass this test"?

Given If 1, then 2

Converse If 2, then 1

2 →

- (1) If Mike passes this test, then he did his homework.
- (2) If Mike does not pass this test, then he did not do his homework.
- (3) If Mike does not pass this test, then he only did half his homework.
- (4) If Mike did not do his homework, then he will not pass this test.

Inverse If not 1, then not 2

Contrapositive If not 2, then not 1

Inverse begins with "In", which rhymes with "n", which stands for "not".

4 In which list are the numbers in order from least to greatest?

- (1) $3.2, \pi, 3\frac{1}{3}, \sqrt{3}$
- (2) $\sqrt{3}, 3.2, \pi, 3\frac{1}{3}$
- (3) $\sqrt{3}, \pi, 3.2, 3\frac{1}{3}$
- (4) $3.2, 3\frac{1}{3}, \sqrt{3}, \pi$

$\sqrt{3} = 1.732050808 \dots$

$\pi = 3.14159 \dots$

$3.2 = 3.20000 \dots$

[2] $3\frac{1}{3} = 3.33333 \dots$

5 The accompanying diagram shows a transformation.

Use this space for computations.

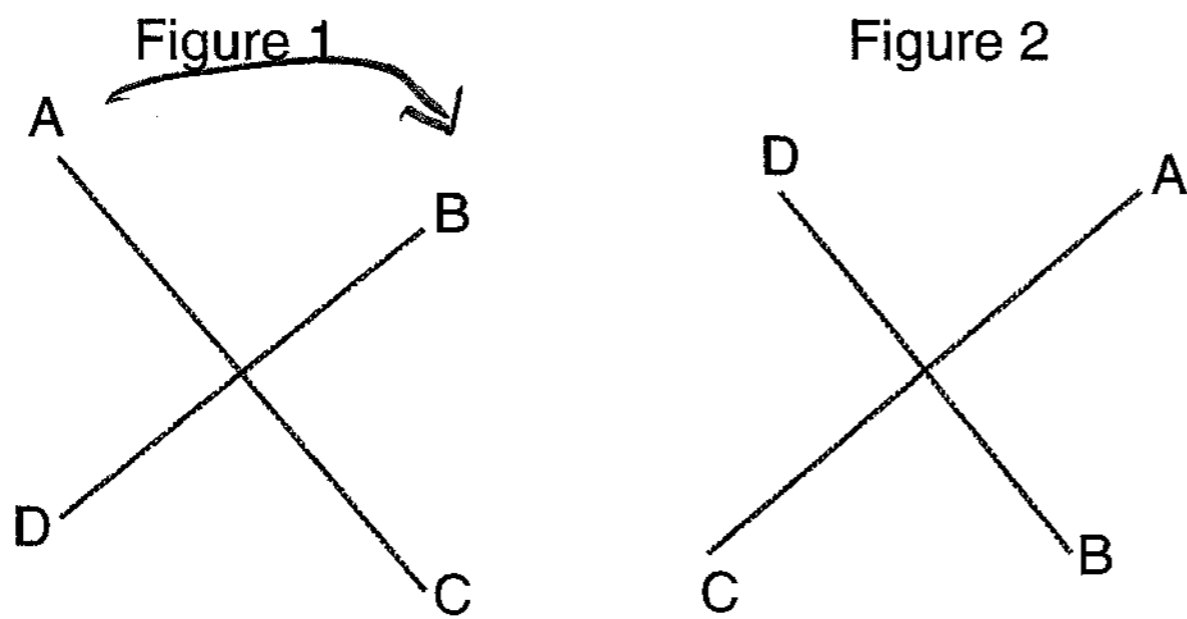

Which transformation performed on figure 1 resulted in figure 2?

- (1) rotation
- (2) reflection
- (3) dilation
- (4) translation

6 The product of $3x^5$ and $2x^4$ is

- (1) $5x^9$
- (2) $5x^{20}$
- (3) $6x^9$
- (4) $6x^{20}$

Handwritten work for problem 6:

$$(3 \times 5) (2 \times 4)$$

$$(3) (x^5) (2) (x^4)$$

$$(3 \cdot 2) (x^{5+4})$$

$$6x^9$$

7 There are 12 people on a basketball team, and the coach needs to choose 5 to put into a game. How many different possible ways can the coach choose a team of 5 if each person has an equal chance of being selected?

- (1) ${}_{12}P_5$
- (2) ${}_5P_{12}$
- (3) ${}_{12}C_5$
- (4) ${}_5C_{12}$

Handwritten notes for problem 7:

$nPr \rightarrow$ Permutation
order matters

$nCr \rightarrow$ Combination
order does not matter

8 Given the true statement: "If a person is eligible to vote then that person is a citizen."

Which statement must also be true?

- (1) Kayla is not a citizen; therefore, she is not eligible to vote.
- (2) Juan is a citizen; therefore, he is eligible to vote.
- (3) Marie is not eligible to vote; therefore, she is not a citizen.
- (4) Morgan has never voted; therefore, he is not a citizen.

Handwritten notes for problem 8:

See notes for problem #3

The contrapositive has the same truth value as the given.

Handwritten note at the bottom:

If not that person is a citizen, then not that person is eligible to vote.

9 Line P and line C lie on a coordinate plane and have equal slopes. Neither line crosses the second or third quadrant. Lines P and C must

- (1) form an angle of 45° (3) be horizontal
 (2) be perpendicular (4) be vertical

Use this space for computations.

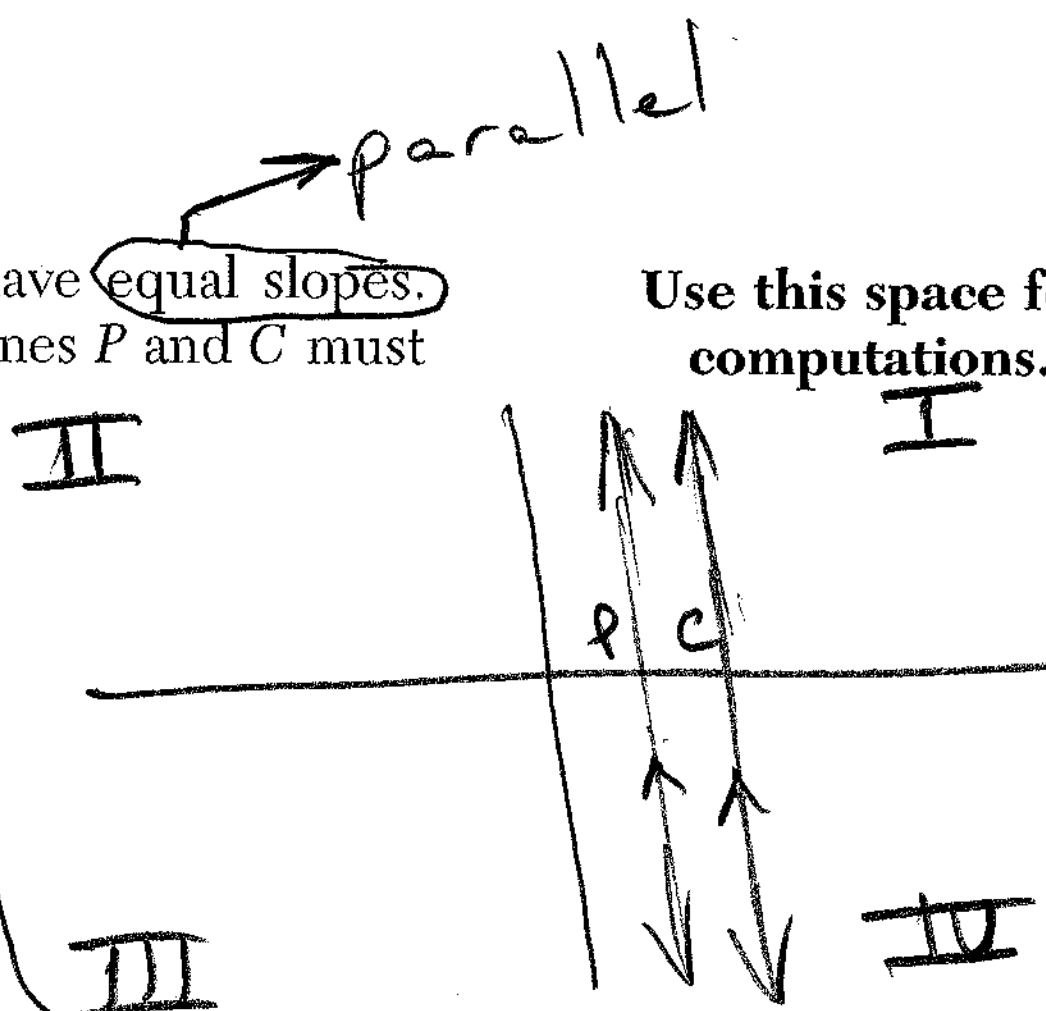

10 The equation $P = 2L + 2W$ is equivalent to

- (1) $L = \frac{P - 2W}{2}$ (3) $2L = \frac{P}{2W}$
 (2) $L = \frac{P + 2W}{2}$ (4) $L = P - W$

Isolate "L"

$$\begin{array}{r} P = 2L + 2W \\ -2W \quad -2W \\ \hline P - 2W = 2L \end{array} \quad \rightarrow \quad \begin{array}{r} P - 2W = 2L \\ \frac{P - 2W}{2} = \frac{2L}{2} \\ \frac{P - 2W}{2} = L \end{array}$$

11 The sum of $\sqrt{75}$ and $\sqrt{3}$ is

- (1) 15 (3) $6\sqrt{3}$
 (2) 18 (4) $\sqrt{78}$

$$\begin{aligned} &\sqrt{75} + \sqrt{3} \\ &\sqrt{25} \sqrt{3} + \sqrt{3} \\ &5\sqrt{3} + \sqrt{3} \\ &6\sqrt{3} \end{aligned}$$

12 Which graph represents the solution set for $2x - 4 \leq 8$ and $x + 5 \geq 7$?

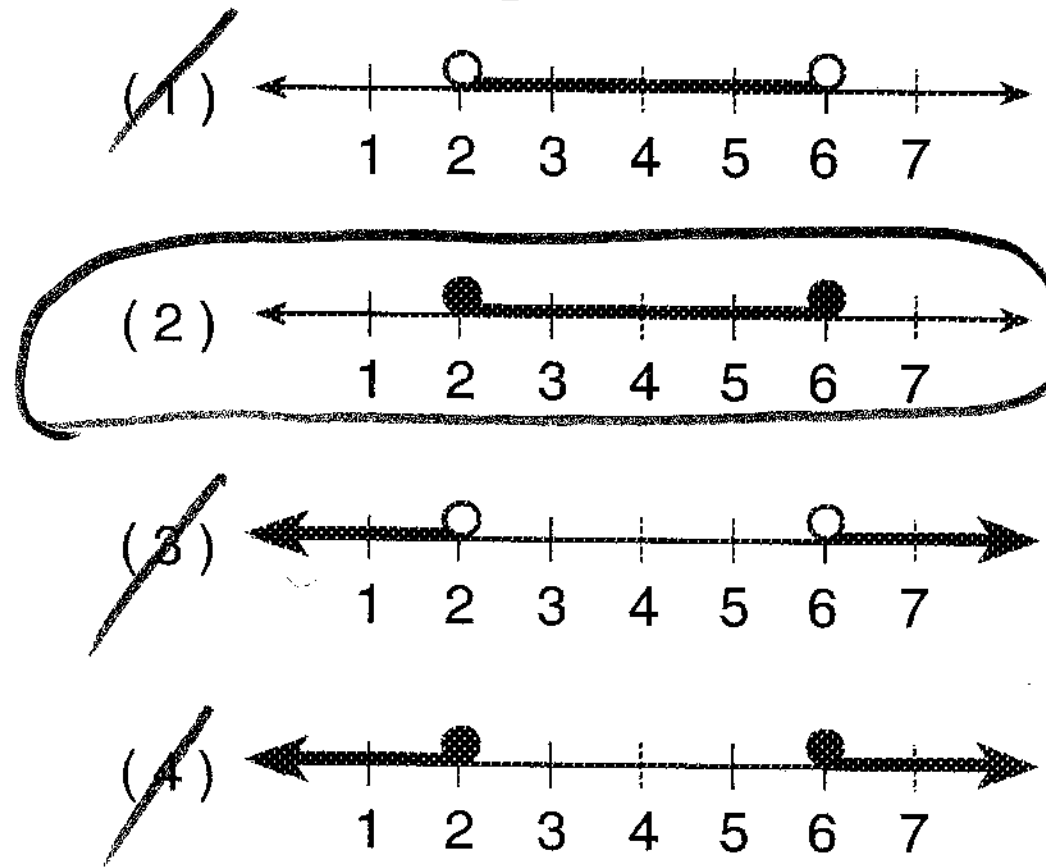

(2)

$$\begin{array}{r} 2x - 4 \leq 8 \\ \frac{2x}{2} - \frac{4}{2} \leq \frac{8}{2} \\ x - 2 \leq 4 \\ +2 \quad +2 \\ \hline x \leq 6 \end{array}$$

$$\begin{array}{r} x + 5 \geq 7 \\ -5 \quad -5 \\ \hline x \geq 2 \end{array}$$

13 If the measure of an angle is represented by $2x$, which expression represents the measure of its complement?

- (1) $180 - 2x$
- (2) $90 - 2x$
- (3) $90 + 2x$
- (4) $88x$

Use this space for computations.

→ 2 angles sum to 90°

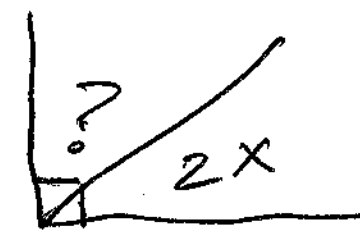

$$2x + ? = 90$$

$$\quad \quad \quad -2x \quad \quad -2x$$

$$? = 90 - 2x$$

14 Which equation illustrates the multiplicative identity element?

- (1) $x + 0 = x$
- (2) $x - x = 0$
- (3) $x \cdot \frac{1}{x} = 1$
- (4) $x \cdot 1 = x$

→ multiplication
→ doesn't change the other number.

1 is the multiplicative identity element

15 The ages of five children in a family are 3, 3, 5, 8, and 18. Which statement is true for this group of data?

- (1) mode > mean
- (2) mean > median
- (3) median = mode
- (4) median > mean

$$\text{Mean} = \frac{3+3+5+8+18}{5} = \frac{37}{5} = 7\frac{2}{5}$$

$$\text{Median} = \text{middle}^\text{th} = 3, 3, 5, 8, 18 = 5$$

$$\text{Mode} = \text{most} = 3, 3, 5, 8, 18 = 3$$

16 In the accompanying diagram of right triangle ABC , $AB = 8$, $BC = 15$, $AC = 17$, and $m\angle ABC = 90$.

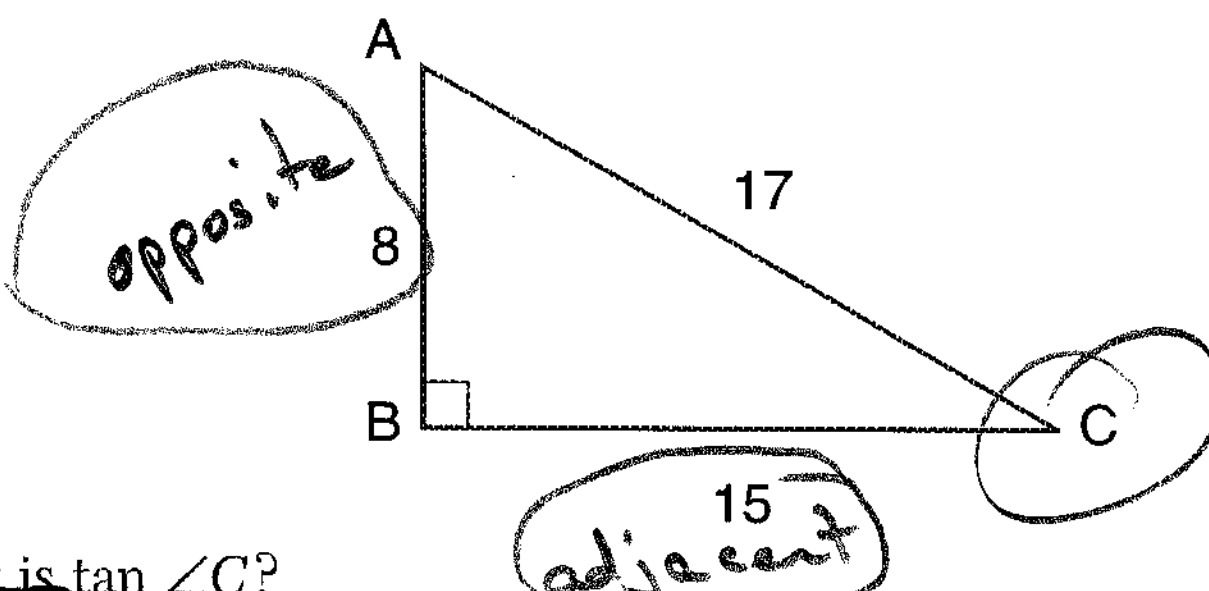

What is $\tan \angle C$?

- (1) $\frac{8}{15}$
- (2) $\frac{17}{15}$
- (3) $\frac{8}{17}$
- (4) $\frac{15}{17}$

SOH-CAH-TOA

We are dealing with the measure of an angle and its opposite and adjacent sides. O and A go with the tangent function \Rightarrow TOA

$$\tan = \frac{\text{opposite}}{\text{adjacent}}$$

$$\tan C = \frac{AB}{BC} = \frac{8}{15}$$

No angle bigger than 90°

3 unequal sides

17 The locus of points equidistant from two sides of an acute scalene triangle is

Use this space for computations.

- (1) an angle bisector (3) a median
 (2) an altitude (4) the third side



18 What are the factors of $x^2 - 10x - 24$?

- ~~(1) $(x-4)(x+6)$~~ (3) $(x-12)(x+2)$
~~(2) $(x-4)(x-6)$~~ (4) $(x+12)(x-2)$

$$\begin{array}{l} (x-4)(x+6) \\ x^2 + 6x - 4x - 24 \\ x^2 + 2x - 24 \end{array}$$

$$\begin{array}{l} (x-12)(x+2) \\ x^2 + 2x - 12x - 24 \\ x^2 - 10x - 24 \end{array}$$

$$\begin{array}{l} (x-4)(x-6) \\ x^2 - 6x - 4x + 24 \\ x^2 - 10x + 24 \end{array}$$

$$\begin{array}{l} (x+12)(x-2) \\ x^2 - 2x + 12 - 24 \\ x^2 + 10x - 24 \end{array}$$

19 What is the value of $\frac{6.3 \times 10^8}{3 \times 10^4}$ in scientific notation?

- (1) 2.1×10^{-2} (3) 2.1×10^{-4}
 (2) 2.1×10^2 (4) 2.1×10^4

6.3	\times	10^8
3	\times	10^4
2.1	\times	10^{8-4}
2.1	\times	10^4

20 In the accompanying figure, what is one pair of alternate interior angles?

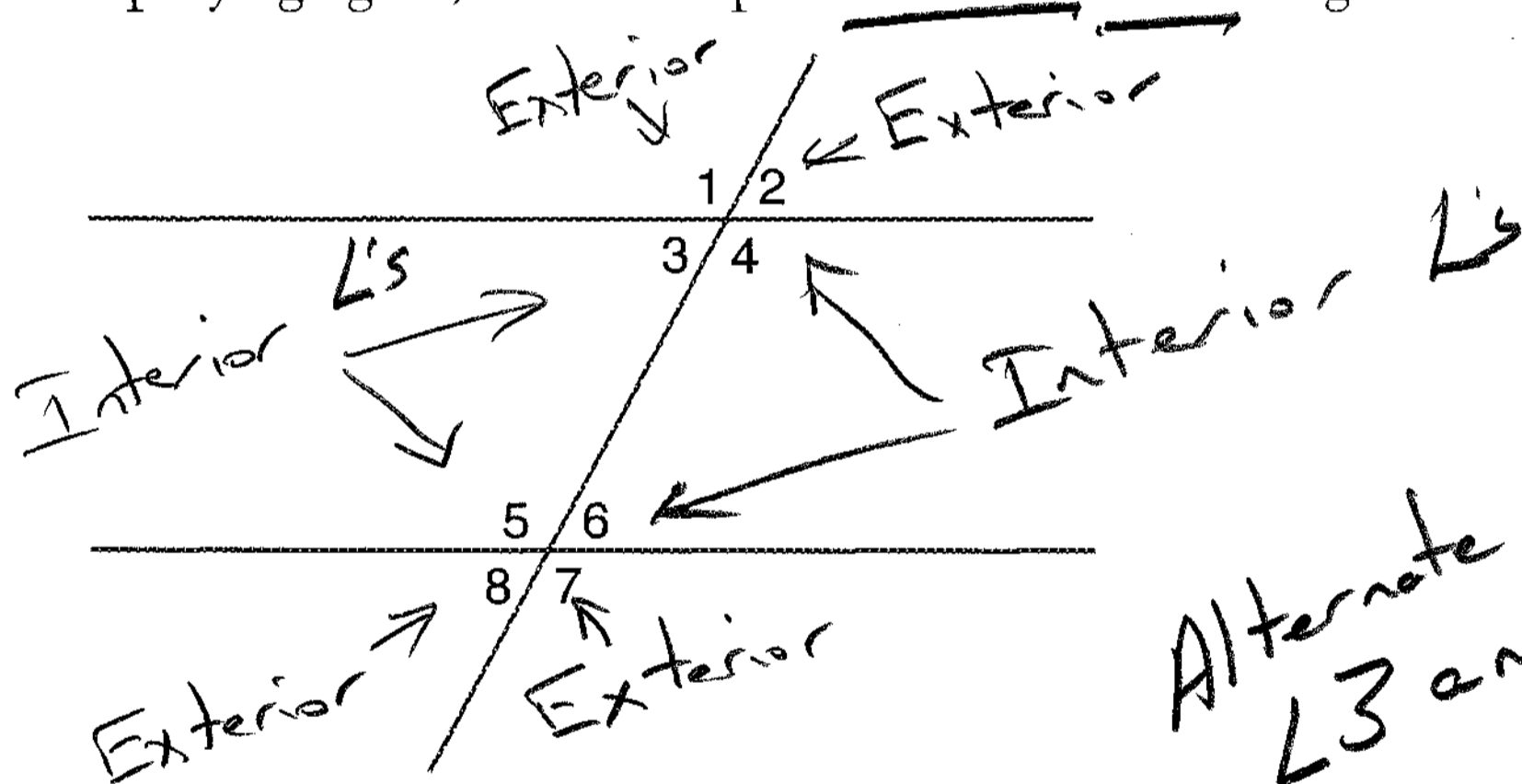

- (1) $\angle 1$ and $\angle 2$ (3) $\angle 4$ and $\angle 6$
 (2) $\angle 4$ and $\angle 5$ (4) $\angle 6$ and $\angle 8$

Part II

Answer all questions in this part. Each correct answer will receive 2 credits. Clearly indicate the necessary steps, including appropriate formula substitutions, diagrams, graphs, charts, etc. For all questions in this part, a correct numerical answer with no work shown will receive only 1 credit. [10]

21 If Laquisha can enter school by any one of three doors and the school has two staircases to the second floor, in how many different ways can Laquisha reach a room on the second floor? Justify your answer by drawing a tree diagram or listing a sample space.

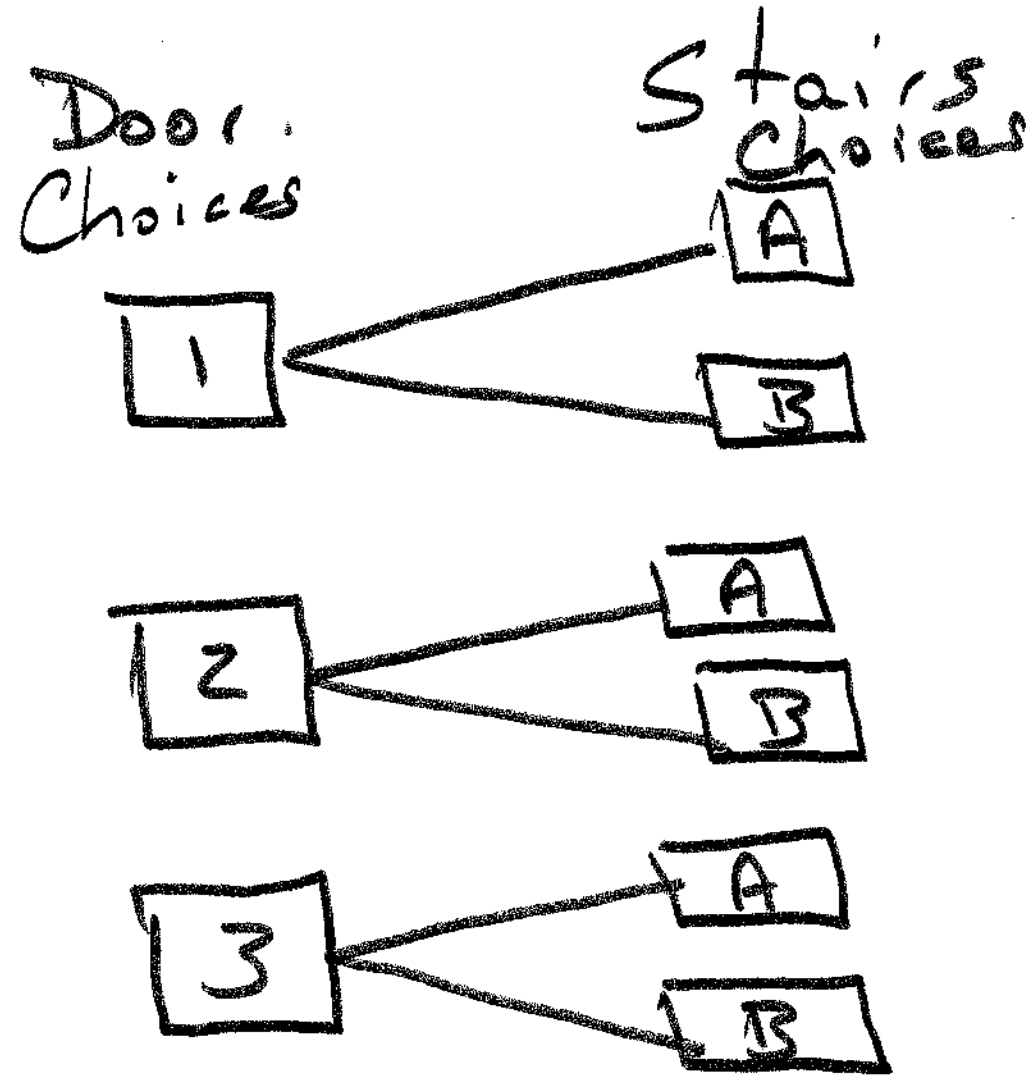

Tree Diagram

Six Different Ways

- 1A
- 1B
- 2A
- 2B
- 3A
- 3B

Sample Space

Answer

22 The world population was 4.2 billion people in 1982. The population in 1999 reached 6 billion. Find the percent of change from 1982 to 1999.

1982 1999
 4.2 Billion 6 Billion

The population increased 1.8 Billion

$$\frac{\text{Amount of Increase}}{\text{Original Amount}} = \frac{1.8}{4.2} = \frac{x}{100}$$

$$180 = 4.2x$$

$$\frac{180}{4.2} = x$$

$$42.85714286\% = x$$

Check
 $142.85714286\% \times 4.2 \text{ Billion}$
 $= 6 \text{ Billion}$



23 Six members of a school's varsity tennis team will march in a parade. How many different ways can the players be lined up if Angela, the team captain, is always at the front of the line?

Choices 1st 2nd 3rd 4th 5th 6th

$$\boxed{1} \times \boxed{5} \times \boxed{4} \times \boxed{3} \times \boxed{2} \times \boxed{1}$$

$$120 \text{ different ways}$$

24 A fish tank with a rectangular base has a volume of 3,360 cubic inches. The length and width of the tank are 14 inches and 12 inches, respectively. Find the height, in inches, of the tank.

$$\rightarrow \text{Volume} = (\text{length}) (\text{width}) (\text{height})$$

$$3,360 = (14) (12) (\text{height})$$

$$3,360 = 168 (\text{height})$$

$$\frac{3,360}{168} = \frac{\cancel{168} \text{ height}}{\cancel{168}}$$

$$20 = \text{height}$$

The tank is 20 inches in height

25 Mr. Smith's class voted on their favorite ice cream flavors, and the results are shown in the accompanying diagram. If there are 20 students in Mr. Smith's class, how many students chose coffee ice cream as their favorite flavor?

Favorite Ice Cream Flavors

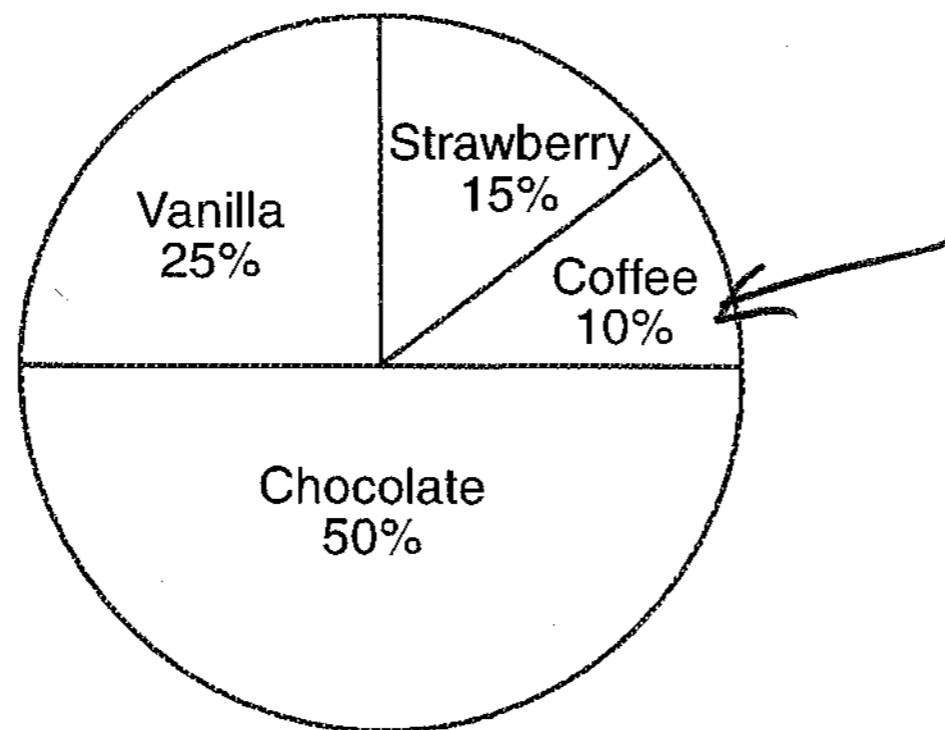

25 Students

$$\frac{\# \text{ students}}{\text{Percent}}$$

$$\Rightarrow \frac{20}{100} = \frac{x}{10}$$

$$20(10) = 100x$$

$$200 = 100x$$

$$\frac{200}{100} = \frac{100x}{100}$$

$$\Rightarrow 2 = x$$

Part III

Answer all questions in this part. Each correct answer will receive 3 credits. Clearly indicate the necessary steps, including appropriate formula substitutions, diagrams, graphs, charts, etc. For all questions in this part, a correct numerical answer with no work shown will receive only 1 credit. [15]

26 Three brothers have ages that are consecutive even integers. The product of the first and third boys' ages is 20 more than twice the second boy's age. Find the age of each of the three boys.

Let x equal the 1st boy's age
 Let $x+2$ equal the second boy's age
 Let $x+4$ equal the third boy's age

The product of the 1st + 3rd is 20 more than twice 2nd

$$(x)(x+4) = +20 + 2(x+2)$$

$$x^2 + 4x = 20 + 2x + 4$$

$$x^2 + 4x = 2x + 24$$

$$-2x \quad -2x$$

$$x^2 + 2x = 24$$

$$-24 \quad -24$$

$$x^2 + 2x - 24 = 0$$

$x = 4$
 $x+2 = 6$
 $x+4 = 8$

27 Arielle has a collection of grasshoppers and crickets. She has 561 insects in all. The number of grasshoppers is twice the number of crickets. Find the number of each type of insect that she has.

G = grasshoppers
 C = crickets

$$G + C = 561 \Rightarrow G = 561 - C$$

$$G = 2C \Rightarrow G = 2C$$

$$2C = 561 - C$$

$$+C \quad +C$$

$$3C = 561$$

$$C = \frac{561}{3} = 187$$

$$G = 2(187) = 374$$

Answer

She has 374 grasshoppers + 187 crickets

$$(x+6)(x-4) = 0$$

$$x+6=0 \quad x-4=0$$

$$x=-6 \quad x=4$$

Not a real age

The boys' ages are 4, 6, +8

check

$$(4)(8) = 20 + (2)(6)$$

$$32 = 20 + 12$$

$$32 = 32 \checkmark$$

Answer to 26

Answer

Check

$$G + C = 561$$

$$374 + 187 = 561 \checkmark$$

$$561 = 561$$

$$G = 2C$$

$$374 = 2(187)$$

$$374 = 374 \checkmark$$

28 The graph of a quadratic equation is shown in the accompanying diagram. The scale on the axes is a unit scale. Write an equation of this graph in standard form.

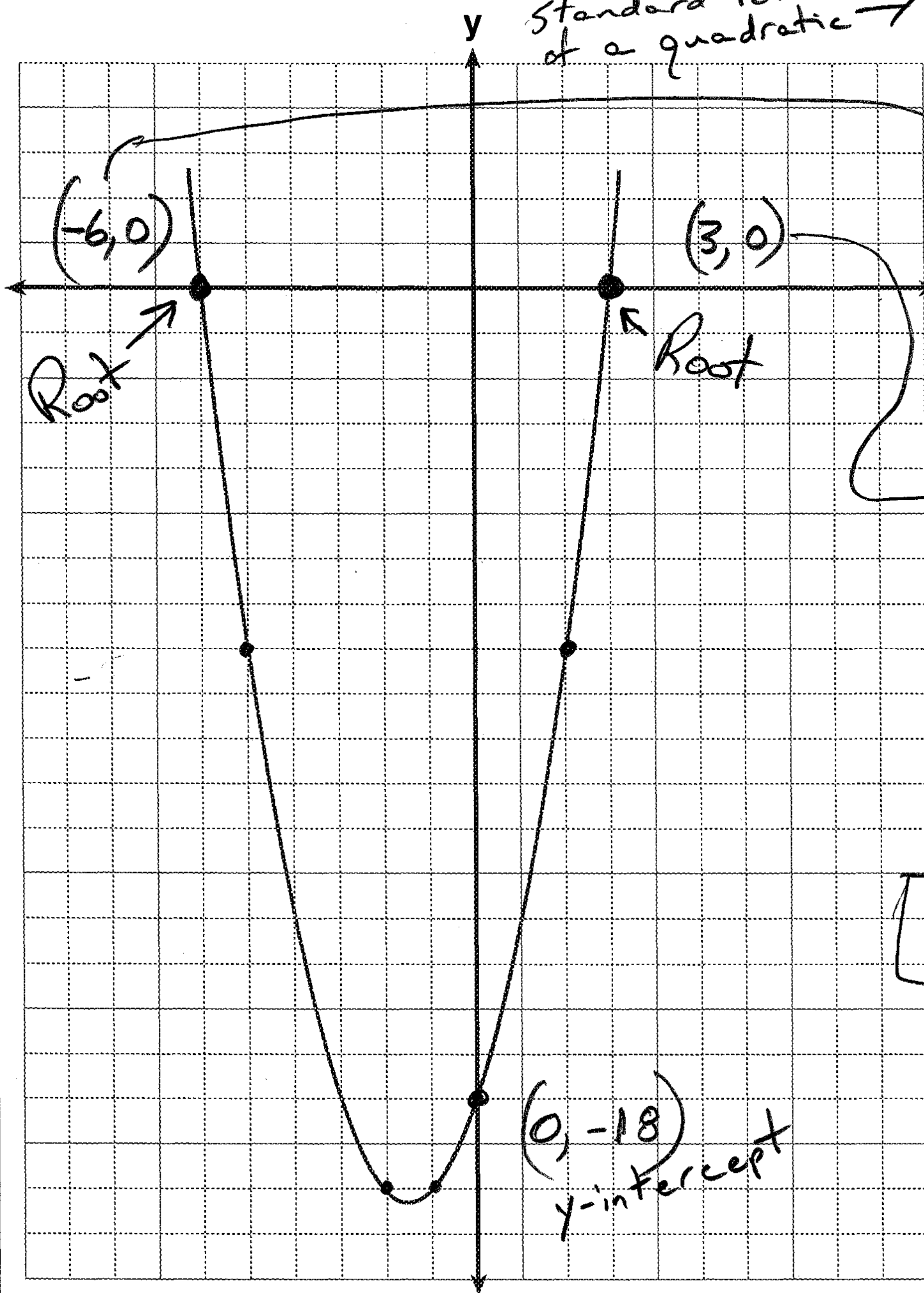

standard form \Rightarrow $ax^2 + bx + c = 0$

$ax^2 + bx + c = 0$
 $ax^2 + bx + 18 = 0$

$x = -6$
 $+6$

$x + 6 = 0$

$x = 3$
 -3

$x - 3 = 0$

$(x + 6)(x - 3) = 0$

$x^2 - 3x + 6x - 18 = 0$

$x^2 + 3x - 18 = 0$
 Answer

Check (from Graphing Calculator)

x	y	
-6	0	✓
-5	-8	✓
-2	-20	✓
-1	-20	✓
0	-18	✓
2	-8	✓
3	0	✓

29 Currently, Tyrone has \$60 and his sister has \$135. Both get an allowance of \$5 each week. Tyrone decides to save his entire allowance, but his sister spends all of hers each week plus an additional \$10 each week. After how many weeks will they each have the same amount of money? [The use of the grid on the next page is optional.]

Tyrone	Sister	
60 ⁰⁰	135 ⁰⁰	Start
+5 ⁰⁰ - 0	+5 ⁰⁰ - 5 ⁰⁰ - 10 ⁰⁰	Week 1
65 ⁰⁰	125 ⁰⁰	End of Week 1
+5 ⁰⁰ - 0	+5 ⁰⁰ - 5 ⁰⁰ - 10 ⁰⁰	Week 2
70 ⁰⁰	115 ⁰⁰	End of Week 2
+5 ⁰⁰ - 0	0 - 10 ⁰⁰	Week 3
75 ⁰⁰	105	End of Week 3
+5	-10	Week 4
80	95	End of Week 4
+5	-10	Week 5
85	85	End of Week 5

They will have the same amount of money after 5 weeks.

Another Solution Strategy

~~Y~~
Axis

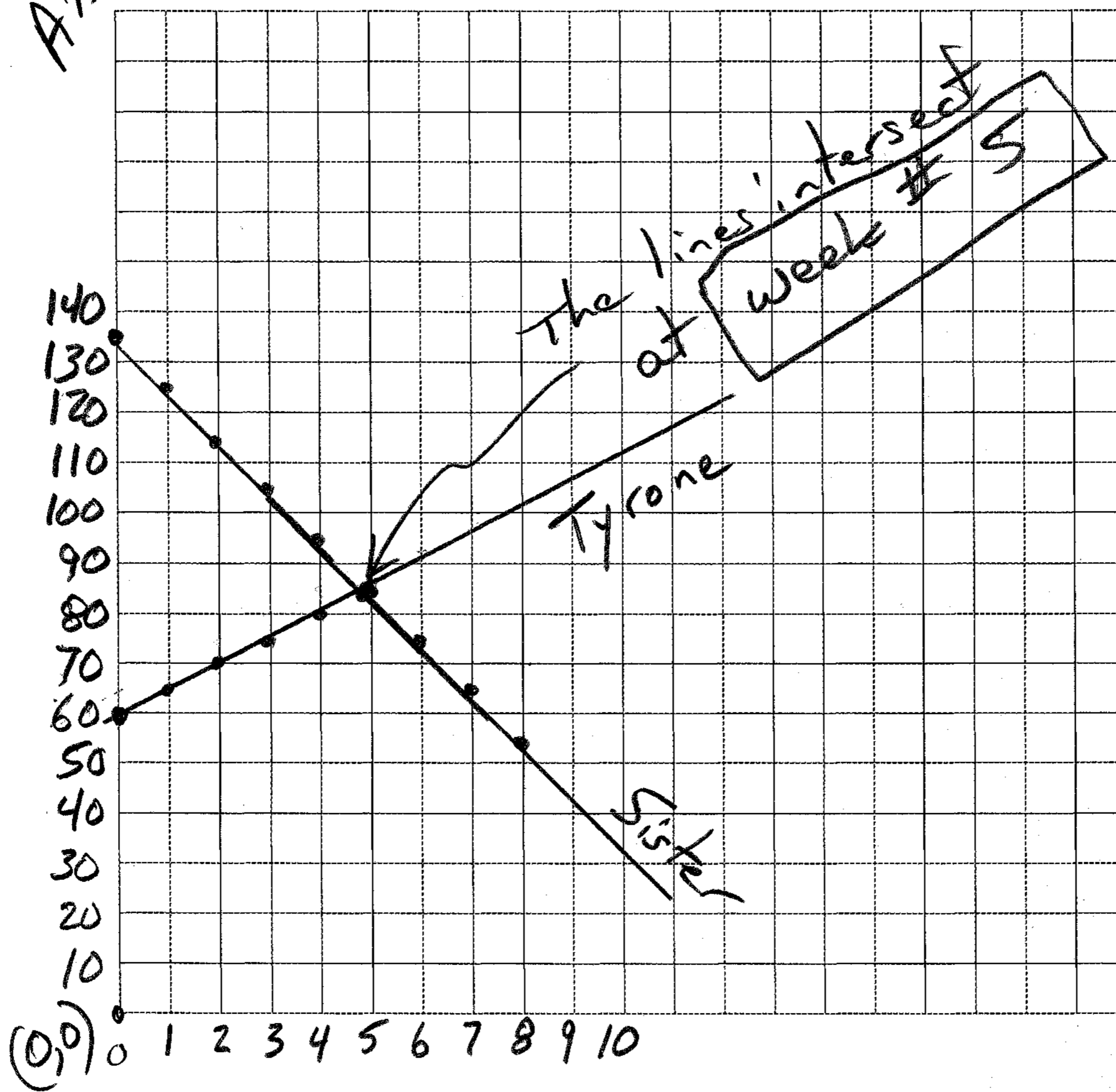

$$\text{Tyrone} = 60^{00} + 5(\text{week})$$

$$T = 60 + 5W$$

$$T = 5W + 60$$

$$\text{Sister} = 135 + (5 - 5 - 10) \text{ week}$$

$$S = 135 - 10W$$

$$S = -10W + 135$$

Solution #3

$$T = 60 + 5W$$

$$S = 135 - 10W$$

$$60 + 5W = 135 - 10W$$

$$\begin{array}{r} 60 + 5W = 135 \\ -60 \quad \quad \quad -60 \\ \hline 15W = 75 \end{array}$$

$$\boxed{W = 5}$$

- 30 A rectangular garden is going to be planted in a person's rectangular backyard, as shown in the accompanying diagram. Some dimensions of the backyard and the width of the garden are given. Find the area of the garden to the nearest square foot.

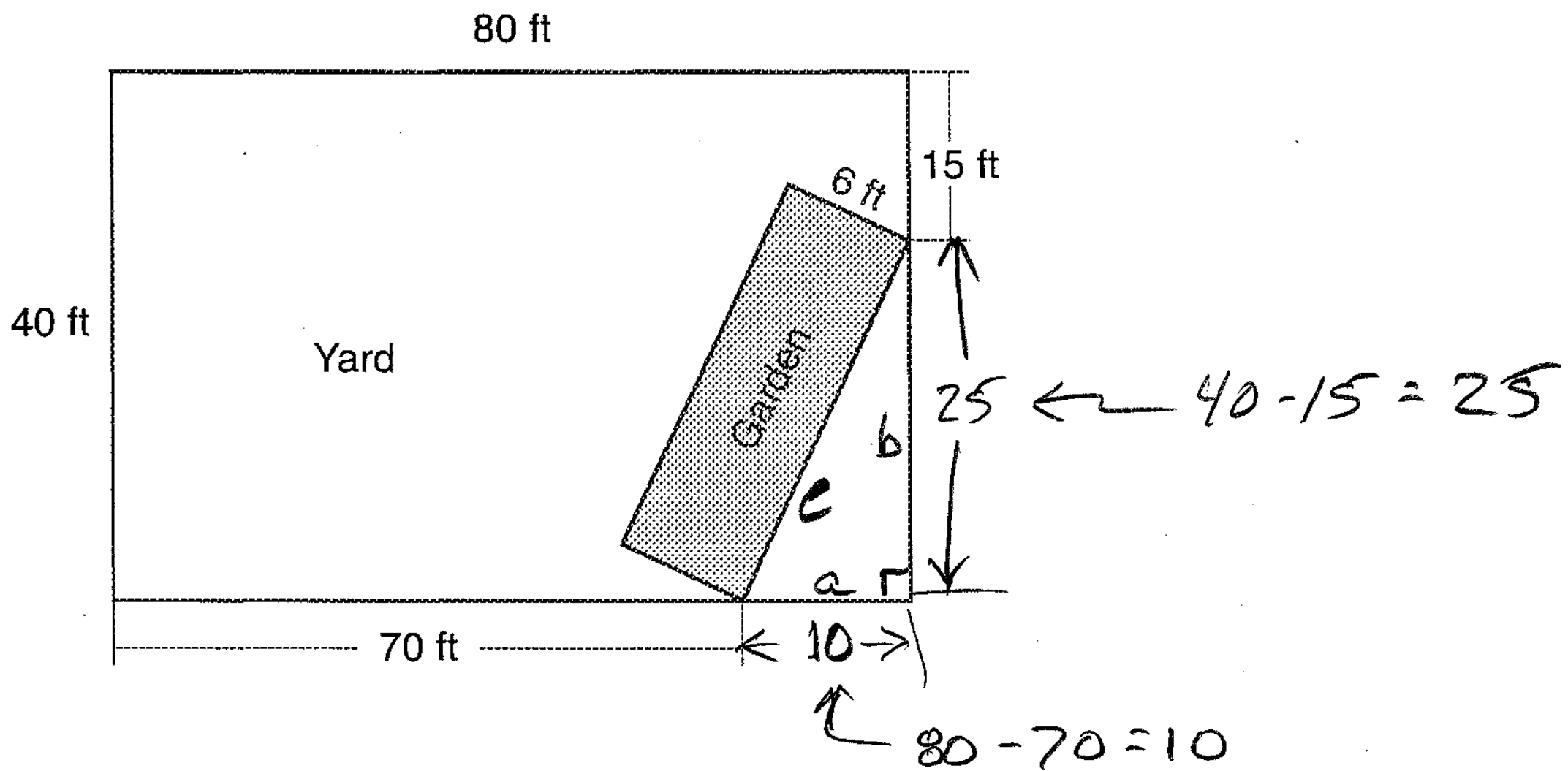

$$a^2 + b^2 = c^2$$

$$10^2 + 25^2 = c^2$$

$$100 + 625 = c^2$$

$$725 = c^2$$

$$\sqrt{725} = c$$

The area of the garden = (length)(width)

$$\text{length} = \sqrt{725}$$

$$\text{width} = 6$$

$$= (\sqrt{725})(6)$$

$$= 161.5549442\dots$$

$$\text{Area} = 162 \text{ ft}^2$$

Part IV

Answer all questions in this part. Each correct answer will receive 4 credits. Clearly indicate the necessary steps, including appropriate formula substitutions, diagrams, graphs, charts, etc. For all questions in this part, a correct numerical answer with no work shown will receive only 1 credit. [20]

31 At the Phoenix Surfboard Company, \$306,000 in profits was made last year. This profit was shared by the four partners in the ratio 3:3:5:7. How much *more* money did the partner with the largest share make than one of the partners with the smallest share?

$$3 + 3 + 5 + 7 = 18 \text{ total shares}$$

x) Partner with largest share got $\frac{7}{18}$

y) Partner with smallest share got $\frac{3}{18}$

$$\frac{7}{18} = \frac{x}{306,000}$$

$$7(306,000) = 18(x)$$

$$2,142,000 = 18x$$

$$119,000 = x$$

$$\frac{3}{18} = \frac{y}{306,000}$$

$$3(306,000) = 18y$$

$$918,000 = 18y$$

$$51,000 = y$$

$119,000$
 $- 51,000$

 $\$68,000$
 More
 Answer

32 Alexandra purchases two doughnuts and three cookies at a doughnut shop and is charged \$3.30. Briana purchases five doughnuts and two cookies at the same shop for \$4.95. All the doughnuts have the same price and all the cookies have the same price. Find the cost of one doughnut and find the cost of one cookie.

D = donuts
C = cookies

Alexandra $2D + 3C = 3.30 \text{ (M}_2) \Rightarrow 4D + 6C = 6.60$

Briana $5D + 2C = 4.95 \text{ (M}_3) \Rightarrow -15D - 6C = -14.85$

$$-11D = -8.25$$

$$(D-11) \frac{-11D}{-11} = \frac{-8.25}{-11}$$

$$D = .75$$

A donut costs 75¢

$$2D + 3C = 3.30$$

$$2(75¢) + 3C = 3.30$$

$$1.50 + 3C = 3.30$$

$$\begin{array}{r} -1.50 \\ -1.50 \\ \hline 3C = 1.80 \end{array}$$

$$C = \frac{1.80}{3}$$

$$C = .60$$

Answers

A cookie costs 60¢

33 On the accompanying grid, draw and label quadrilateral $ABCD$ with points $A(1,2)$, $B(6,1)$, $C(7,6)$, and $D(3,7)$. On the same set of axes, plot and label quadrilateral $A'B'C'D'$, the reflection of quadrilateral $ABCD$ in the y -axis. Determine the area, in square units, of quadrilateral $A'B'C'D'$.

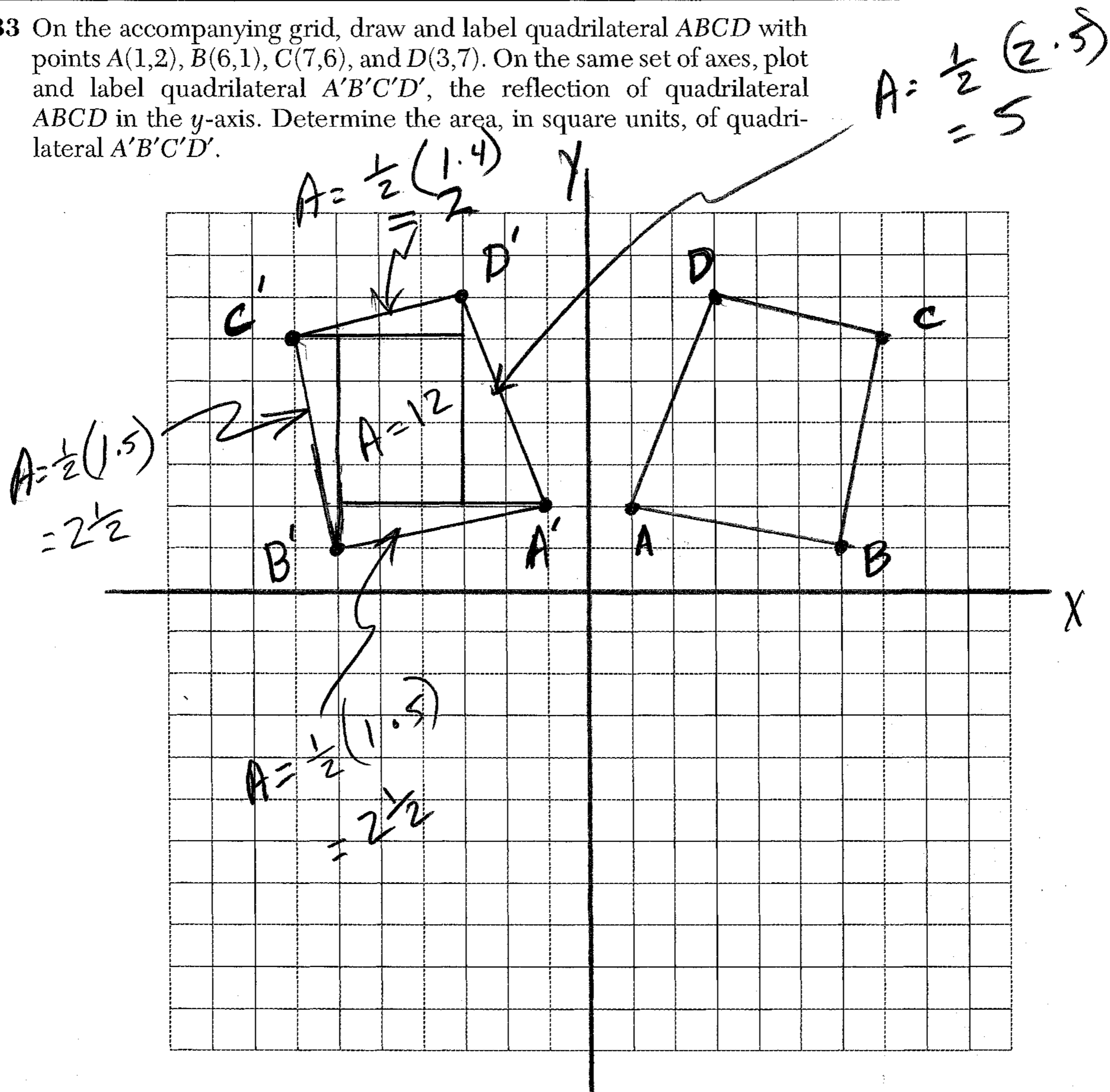

The area of quadrilateral $A'B'C'D'$ is the sum of the areas of the rectangle (12) and the 4 triangles ($2\frac{1}{2} + 2\frac{1}{2} + 2 + 5$).

$$12 + 2\frac{1}{2} + 2\frac{1}{2} + 2 + 5 = \boxed{24 \text{ square units}} = \text{Area}$$

34 Sarah's mathematics grades for one marking period were 85, 72, 97, 81, 77, 93, 100, 75, 86, 70, 96, and 80.

a Complete the tally sheet and frequency table below, and construct and label a frequency histogram for Sarah's grades using the accompanying grid.

Interval (grades)	Tally	Frequency
61-70		1
71-80		4
81-90		3
91-100		4

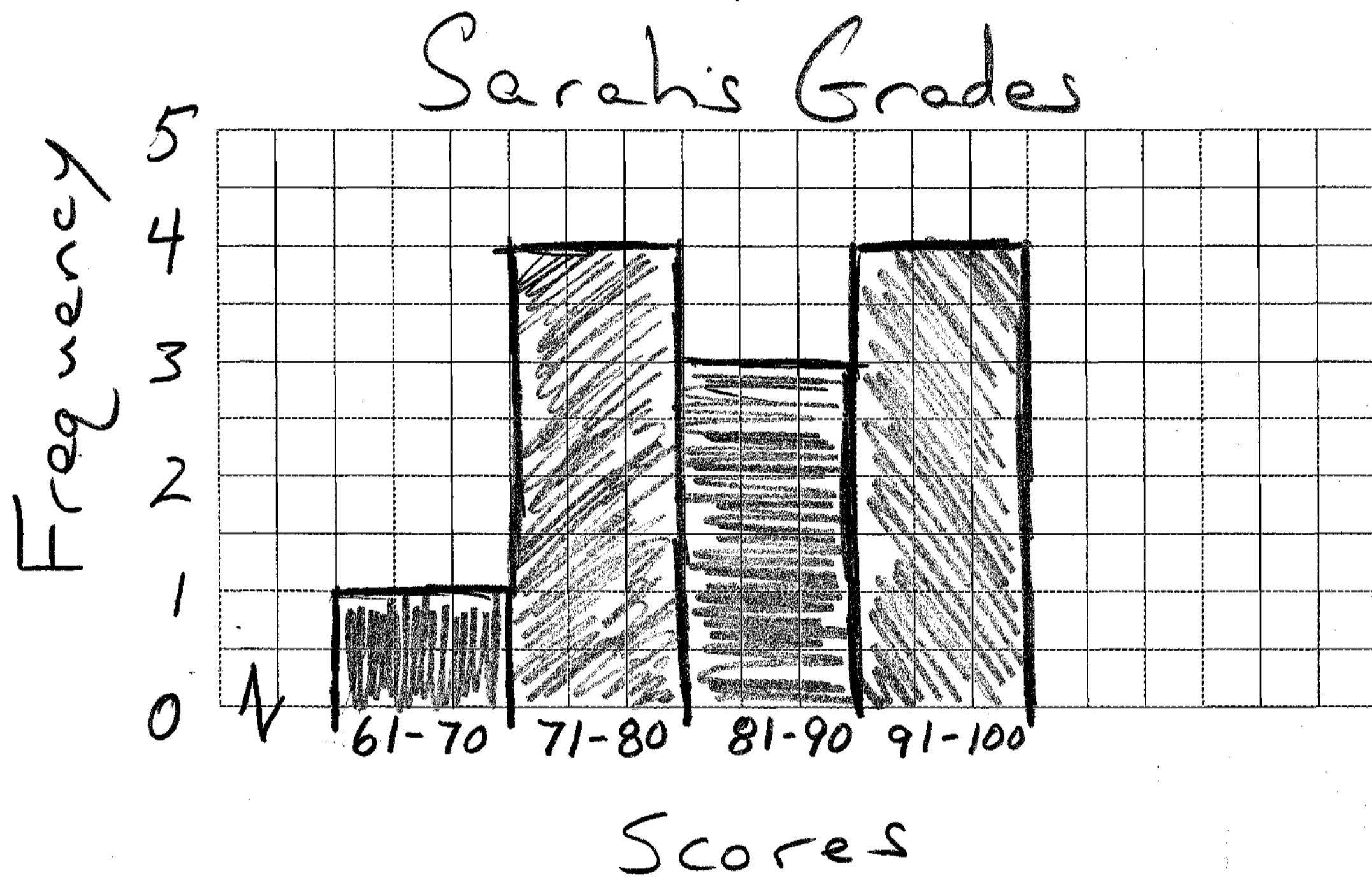

b Which interval contains the 75th percentile (upper quartile)?

12 scores

1 2 3 4 5 6 | 7 8 9 | 10 11 12

Median
50th percentile

Q₃

75th percentile is midway between the 9th and 10th score

which is in the
91-100 Interval

35 On the accompanying set of axes, graph and label the following lines:

$$\begin{aligned}y &= 5 \\x &= -4 \\y &= \frac{5}{4}x + 5\end{aligned}$$

Calculate the area, in square units, of the triangle formed by the three points of intersection.

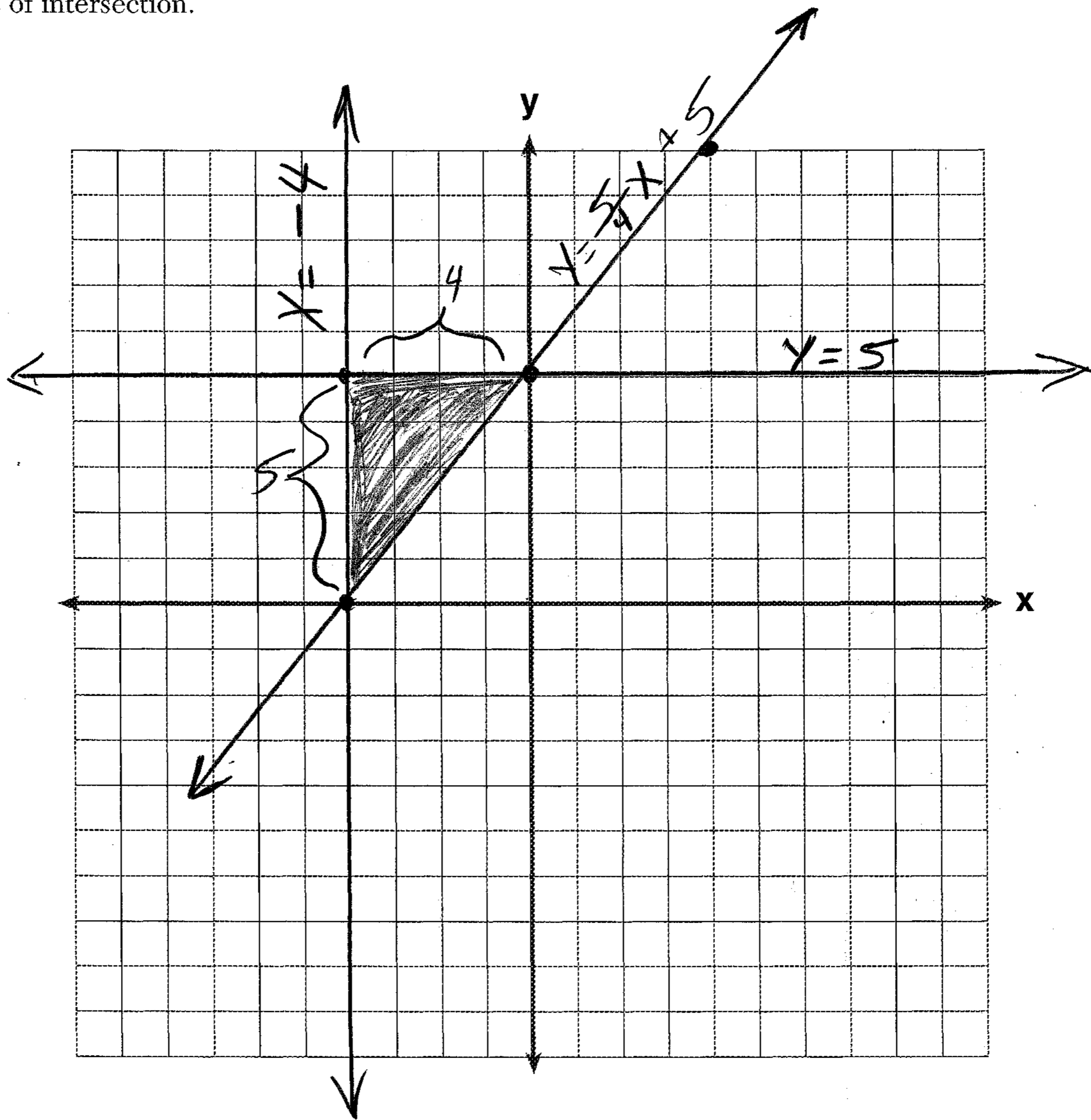

$$A = \frac{1}{2}bh$$

$$A = \frac{1}{2}(4)(5)$$

$$A = \frac{1}{2}(20)$$

$$A = 10 \text{ square units}$$

The University of the State of New York

REGENTS HIGH SCHOOL EXAMINATION

MATHEMATICS A

Monday, January 27, 2003 — 1:15 to 4:15 p.m., only

ANSWER SHEET

Student Sex: Male Female Grade
Teacher Steve Watson School IHS @ PH

Your answers to Part I should be recorded on this answer sheet.

Part I

Answer all 20 questions in this part.

1 <u>3</u>	6 <u>3</u>	11 <u>3</u>	16 <u>1</u>
2 <u>2</u>	7 <u>3</u>	12 <u>2</u>	17 <u>1</u>
3 <u>4</u>	8 <u>1</u>	13 <u>2</u>	18 <u>3</u>
4 <u>3</u>	9 <u>4</u>	14 <u>4</u>	19 <u>4</u>
5 <u>1</u>	10 <u>1</u>	15 <u>2</u>	20 <u>2</u>

Your answers for Parts II, III, and IV should be written in the test booklet.

The declaration below should be signed when you have completed the examination.

I do hereby affirm, at the close of this examination, that I had no unlawful knowledge of the questions or answers prior to the examination and that I have neither given nor received assistance in answering any of the questions during the examination.

Signature

Tear Here

Tear Here