

**0811ia**

- 1 The number of calories burned while jogging varies directly with the number of minutes spent jogging. If George burns 150 calories by jogging for 20 minutes, how many calories does he burn by jogging for 30 minutes?
- 1) 100
  - 2) 180
  - 3) 200
  - 4) 225

- 2 The scatter plot below represents the relationship between the number of peanuts a student eats and the student's bowling score.

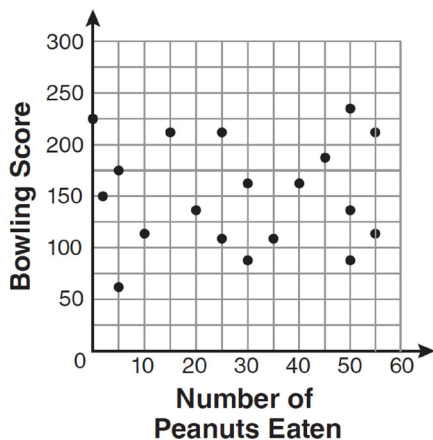

- Which conclusion about the scatter plot is valid?
- 1) There is almost no relationship between eating peanuts and bowling score.
  - 2) Students who eat more peanuts have higher bowling scores.
  - 3) Students who eat more peanuts have lower bowling scores.
  - 4) No bowlers eat peanuts.

- 3 If the universal set is {pennies, nickels, dimes, quarters}, what is the complement of the set {nickels}?
- 1) { }
  - 2) {pennies, quarters}
  - 3) {pennies, dimes, quarters}
  - 4) {pennies, nickels, dimes, quarters}
- 4 Which situation does *not* describe a causal relationship?
- 1) The higher the volume on a radio, the louder the sound will be.
  - 2) The faster a student types a research paper, the more pages the paper will have.
  - 3) The shorter the distance driven, the less gasoline that will be used.
  - 4) The slower the pace of a runner, the longer it will take the runner to finish the race.
- 5 A cylinder has a diameter of 10 inches and a height of 2.3 inches. What is the volume of this cylinder, to the *nearest tenth of a cubic inch*?
- 1) 72.3
  - 2) 83.1
  - 3) 180.6
  - 4) 722.6

- 6 Based on the box-and-whisker plot below, which statement is *false*?

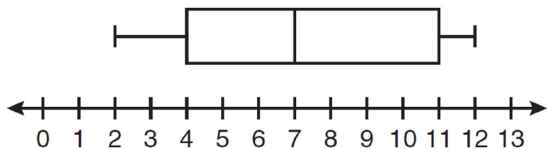

- 1) The median is 7.
  - 2) The range is 12.
  - 3) The first quartile is 4.
  - 4) The third quartile is 11.
- 7 The ninth grade class at a local high school needs to purchase a park permit for \$250.00 for their upcoming class picnic. Each ninth grader attending the picnic pays \$0.75. Each guest pays \$1.25. If 200 ninth graders attend the picnic, which inequality can be used to determine the number of guests,  $x$ , needed to cover the cost of the permit?
- 1)  $0.75x - (1.25)(200) \geq 250.00$
  - 2)  $0.75x + (1.25)(200) \geq 250.00$
  - 3)  $(0.75)(200) - 1.25x \geq 250.00$
  - 4)  $(0.75)(200) + 1.25x \geq 250.00$
- 8 Which equation represents the line that passes through the point  $(1,5)$  and has a slope of  $-2$ ?
- 1)  $y = -2x + 7$
  - 2)  $y = -2x + 11$
  - 3)  $y = 2x - 9$
  - 4)  $y = 2x + 3$

- 9 What is the solution of the system of equations  $2x - 5y = 11$  and  $-2x + 3y = -9$ ?

- 1)  $(-3, -1)$
- 2)  $(-1, 3)$
- 3)  $(3, -1)$
- 4)  $(3, 1)$

- 10 Which algebraic expression represents 15 less than  $x$  divided by 9?

- 1)  $\frac{x}{9} - 15$
- 2)  $9x - 15$
- 3)  $15 - \frac{x}{9}$
- 4)  $15 - 9x$

- 11 What are the vertex and the axis of symmetry of the parabola shown in the graph below?

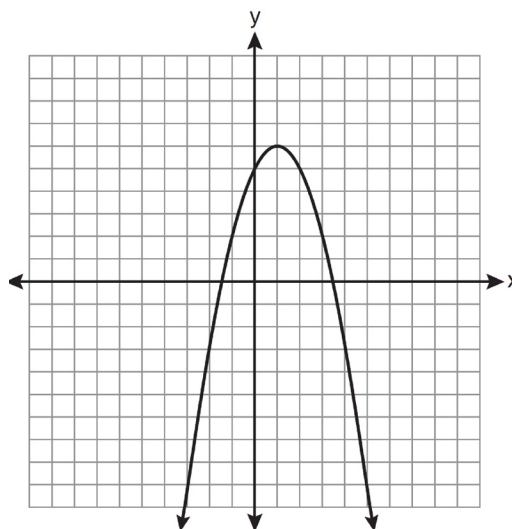

- 1) vertex:  $(1, 6)$ ; axis of symmetry:  $y = 1$
- 2) vertex:  $(1, 6)$ ; axis of symmetry:  $x = 1$
- 3) vertex:  $(6, 1)$ ; axis of symmetry:  $y = 1$
- 4) vertex:  $(6, 1)$ ; axis of symmetry:  $x = 1$

- 12 The diagram below shows right triangle  $ABC$ .

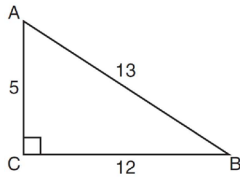

Which ratio represents the tangent of  $\angle ABC$ ?

- 1)  $\frac{5}{13}$
- 2)  $\frac{5}{12}$
- 3)  $\frac{12}{13}$
- 4)  $\frac{12}{5}$

- 13 What is the value of the expression  $-3x^2y + 4x$  when  $x = -4$  and  $y = 2$ ?

- 1)  $-112$
- 2)  $-80$
- 3)  $80$
- 4)  $272$

- 14 Which expression is equivalent to  $-3x(x - 4) - 2x(x + 3)$ ?

- 1)  $-x^2 - 1$
- 2)  $-x^2 + 18x$
- 3)  $-5x^2 - 6x$
- 4)  $-5x^2 + 6x$

- 15 The data in the table below are graphed, and the slope is examined.

x	y
0.5	9.0
1	8.75
1.5	8.5
2	8.25
2.5	8.0

The rate of change represented in this table can be described as

- 1) negative
- 2) positive
- 3) undefined
- 4) zero

- 16 The length of a rectangle is 3 inches more than its width. The area of the rectangle is 40 square inches. What is the length, in inches, of the rectangle?

- 1) 5
- 2) 8
- 3) 8.5
- 4) 11.5

- 17 In interval notation, the set of all real numbers greater than  $-6$  and less than or equal to  $14$  is represented by

- 1)  $(-6, 14)$
- 2)  $[-6, 14)$
- 3)  $(-6, 14]$
- 4)  $[-6, 14]$

Integrated Algebra Regents Exam 0811

[www.jmap.org](http://www.jmap.org)

- 18 Which equation represents a quadratic function?
- 1)  $y = x + 2$
  - 2)  $y = |x + 2|$
  - 3)  $y = x^2$
  - 4)  $y = 2^x$
- 19 Ben has four more than twice as many CDs as Jake. If they have a total of 31 CDs, how many CDs does Jake have?
- 1) 9
  - 2) 13
  - 3) 14
  - 4) 22
- 20 What are the roots of the equation  $x^2 - 5x + 6 = 0$ ?
- 1) 1 and  $-6$
  - 2) 2 and 3
  - 3)  $-1$  and 6
  - 4)  $-2$  and  $-3$
- 21 What is the solution of the inequality  $-6x - 17 \geq 8x + 25$ ?
- 1)  $x \geq 3$
  - 2)  $x \leq 3$
  - 3)  $x \geq -3$
  - 4)  $x \leq -3$
- 22 Which set of data can be classified as qualitative?
- 1) scores of students in an algebra class
  - 2) ages of students in a biology class
  - 3) numbers of students in history classes
  - 4) eye colors of students in an economics class
- 23 Jack wants to replace the flooring in his rectangular kitchen. He calculates the area of the floor to be 12.8 square meters. The actual area of the floor is 13.5 square meters. What is the relative error in calculating the area of the floor, to the *nearest thousandth*?
- 1) 0.051
  - 2) 0.052
  - 3) 0.054
  - 4) 0.055
- 24 The current student population of the Brentwood Student Center is 2,000. The enrollment at the center increases at a rate of 4% each year. To the *nearest whole number*, what will the student population be closest to in 3 years?
- 1) 2,240
  - 2) 2,250
  - 3) 5,488
  - 4) 6,240
- 25 Maria has a set of 10 index cards labeled with the digits 0 through 9. She puts them in a bag and selects one at random. The outcome that is most likely to occur is selecting
- 1) an odd number
  - 2) a prime number
  - 3) a number that is at most 5
  - 4) a number that is divisible by 3
- 26 A right triangle contains a  $38^\circ$  angle whose adjacent side measures 10 centimeters. What is the length of the hypotenuse, to the *nearest hundredth of a centimeter*?
- 1) 7.88
  - 2) 12.69
  - 3) 12.80
  - 4) 16.24

- 27 Which ordered pair is in the solution set of the system of inequalities shown in the graph below?

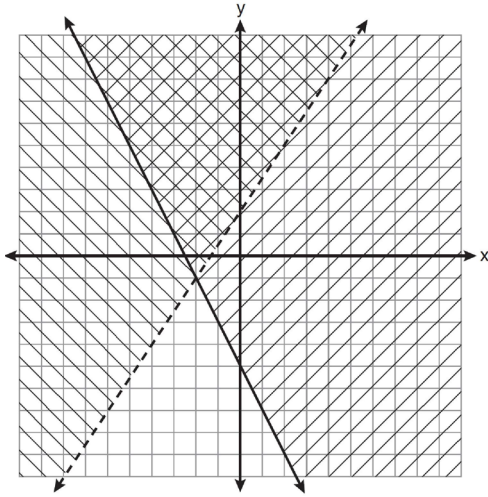

- 1)  $(-2, -1)$
- 2)  $(-2, 2)$
- 3)  $(-2, -4)$
- 4)  $(2, -2)$

- 28 A garden is in the shape of an isosceles trapezoid and a semicircle, as shown in the diagram below. A fence will be put around the perimeter of the entire garden.

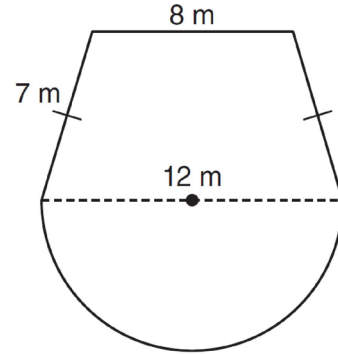

Which expression represents the length of fencing, in meters, that will be needed?

- 1)  $22 + 6\pi$
  - 2)  $22 + 12\pi$
  - 3)  $15 + 6\pi$
  - 4)  $15 + 12\pi$
- 29 Which expression represents  $36x^2 - 100y^6$  factored completely?
- 1)  $2(9x + 25y^3)(9x - 25y^3)$
  - 2)  $4(3x + 5y^3)(3x - 5y^3)$
  - 3)  $(6x + 10y^3)(6x - 10y^3)$
  - 4)  $(18x + 50y^3)(18x - 50y^3)$

30 What is the quotient of  $\frac{x}{x+4}$  divided by  $\frac{2x}{x^2-16}$ ?

- 1)  $\frac{2}{x-4}$
- 2)  $\frac{2x^2}{x-4}$
- 3)  $\frac{2x^2}{x^2-16}$
- 4)  $\frac{x-4}{2}$

31 Solve for  $c$  in terms of  $a$  and  $b$ :  $bc + ac = ab$

32 Ms. Hopkins recorded her students' final exam scores in the frequency table below.

Interval	Tally	Frequency
61–70	###	5
71–80		4
81–90	###	9
91–100	###	6

On the grid below, construct a frequency histogram based on the table.

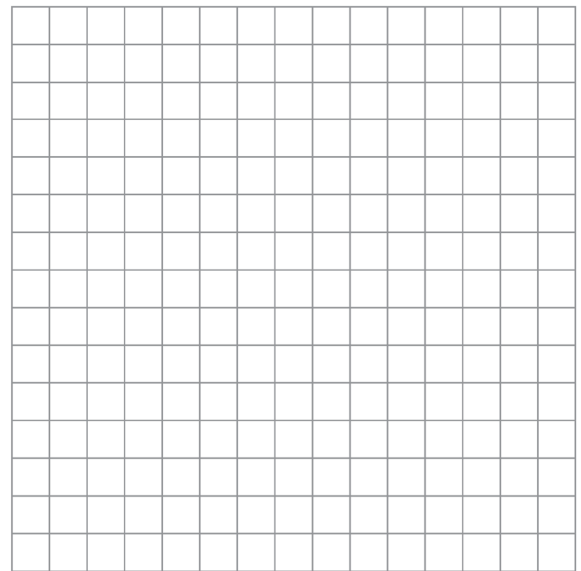

33 Mrs. Chen owns two pieces of property. The areas of the properties are 77,120 square feet and 33,500 square feet.

43,560 square feet = 1 acre
-----------------------------

Find the total number of acres Mrs. Chen owns, to the *nearest hundredth of an acre*.

- 34 On the set of axes below, graph and label the equations  $y = |x|$  and  $y = 3|x|$  for the interval  $-3 \leq x \leq 3$ .

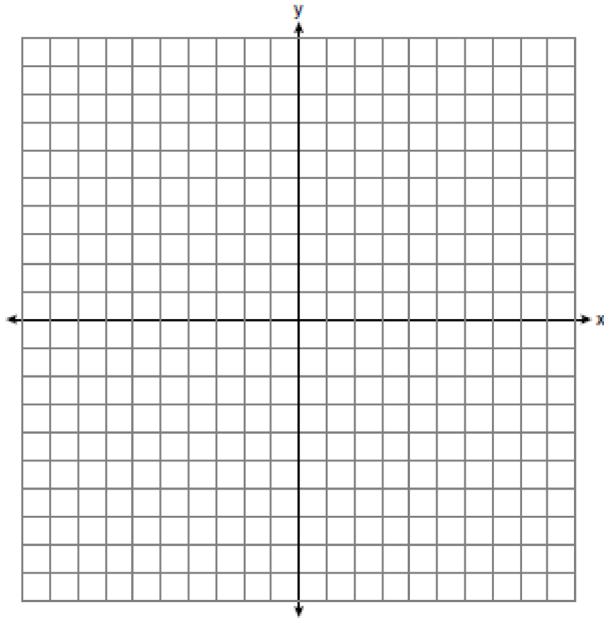

Explain how changing the coefficient of the absolute value from 1 to 3 affects the graph.

- 35 A trapezoid is shown below.

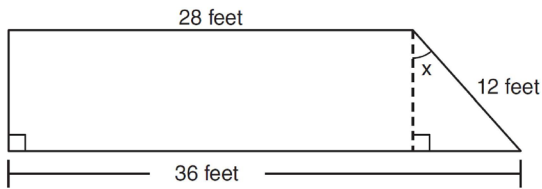

Calculate the measure of angle  $x$ , to the *nearest tenth of a degree*.

- 36 Express  $\frac{16\sqrt{21}}{2\sqrt{7}} - 5\sqrt{12}$  in simplest radical form.

- 37 Vince buys a box of candy that consists of six chocolate pieces, four fruit-flavored pieces, and two mint pieces. He selects three pieces of candy at random, without replacement. Calculate the probability that the first piece selected will be fruit flavored and the other two will be mint. Calculate the probability that all three pieces selected will be the same type of candy.

- 38 On the set of axes below, solve the following system of equations graphically and state the coordinates of *all* points in the solution set.

$$y = -x^2 + 6x - 3$$

$$x + y = 7$$

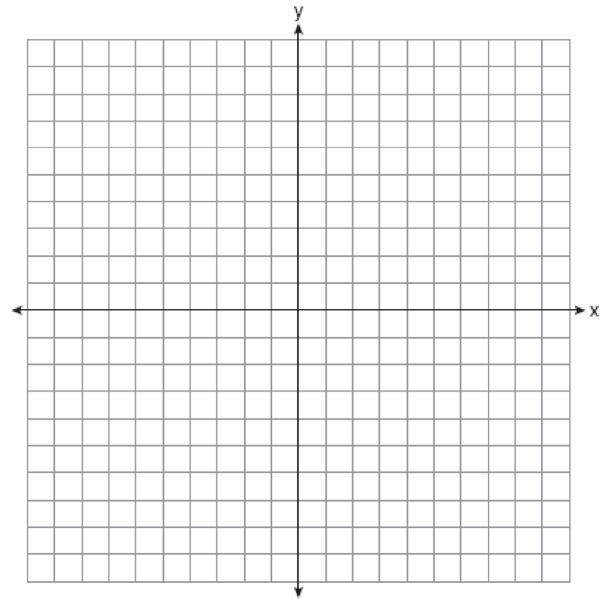

- 39 Solve for  $m$ :  $\frac{m}{5} + \frac{3(m-1)}{2} = 2(m-3)$

## 0811ia

## Answer Section

1 ANS: 4

$$\frac{150}{20} = \frac{x}{30}$$

$$20x = 4500$$

$$x = 225$$

PTS: 2 REF: 081101ia STA: A.N.5 TOP: Direct Variation

2 ANS: 1 PTS: 2 REF: 081102ia STA: A.S.12

TOP: Scatter Plots

3 ANS: 3 PTS: 2 REF: 081103ia STA: A.A.30

TOP: Set Theory

4 ANS: 2 PTS: 2 REF: 081104ia STA: A.S.14

TOP: Analysis of Data

5 ANS: 3

$$V = \pi r^2 h = \pi \cdot 5^2 \cdot 2.3 \approx 180.6$$

PTS: 2 REF: 081105ia STA: A.G.2 TOP: Volume

6 ANS: 2 PTS: 2 REF: 081106ia STA: A.S.6

TOP: Box-and-Whisker Plots

7 ANS: 4 PTS: 2 REF: 081107ia STA: A.A.5

TOP: Modeling Inequalities

8 ANS: 1

$$y = mx + b$$

$$5 = (-2)(1) + b$$

$$b = 7$$

PTS: 2 REF: 081108ia STA: A.A.34 TOP: Writing Linear Equations

9 ANS: 3

$$2x - 5y = 11 \quad 2x - 5(-1) = 11$$

$$-2x + 3y = -9 \quad 2x = 6$$

$$-2y = 2 \quad x = 3$$

$$y = -1$$

PTS: 2 REF: 081109ia STA: A.A.10 TOP: Solving Linear Systems

10 ANS: 1 PTS: 2 REF: 081110ia STA: A.A.1

TOP: Expressions

11 ANS: 2 PTS: 2 REF: 081111ia STA: A.G.10

TOP: Identifying the Vertex of a Quadratic Given Graph



12 ANS: 2

$$\tan ABC = \frac{\text{opposite}}{\text{adjacent}} = \frac{5}{12}$$

PTS: 2

REF: 081112ia

STA: A.A.42

TOP: Trigonometric Ratios

13 ANS: 1

$$-3(-4)^2(2) + 4(-4) = -96 - 16 = -112$$

PTS: 2

REF: 081113ia

STA: A.N.6

TOP: Evaluating Expressions

14 ANS: 4

$$-3x(x-4) - 2x(x+3) = -3x^2 + 12x - 2x^2 - 6x = -5x^2 + 6x$$

PTS: 2

REF: 081114ia

STA: A.A.13

TOP: Addition and Subtraction of Monomials

15 ANS: 1

PTS: 2

REF: 081115ia

STA: A.A.32

TOP: Slope

16 ANS: 2

$$l(l-3) = 40$$

$$l^2 - 3l - 40 = 0$$

$$(l-8)(l+5) = 0$$

$$l = 8$$

PTS: 2

REF: 081116ia

STA: A.A.8

TOP: Geometric Applications of Quadratics

17 ANS: 3

PTS: 2

REF: 081117ia

STA: A.A.29

TOP: Set Theory

18 ANS: 3

PTS: 2

REF: 081118ia

STA: A.G.4

TOP: Families of Functions

19 ANS: 1

$$b = 2j + 4 \quad 2j + 4 = 31 - j$$

$$b + j = 31 \quad 3j = 27$$

$$b = 31 - j \quad j = 9$$

PTS: 2

REF: 081119ia

STA: A.A.7

TOP: Writing Linear Systems

20 ANS: 2

$$x^2 - 5x + 6 = 0$$

$$(x-3)(x-2) = 0$$

$$x = 3 \quad x = 2$$

PTS: 2

REF: 081120ia

STA: A.A.28

TOP: Roots of Quadratics

- 21 ANS: 4  
 $-6x - 17 \geq 8x + 25$   
 $-42 \geq 14x$   
 $-3 \geq x$
- PTS: 2 REF: 081121ia STA: A.A.24 TOP: Solving Inequalities
- 22 ANS: 4  
 The other situations are quantitative.
- PTS: 2 REF: 081122ia STA: A.S.1 TOP: Analysis of Data
- 23 ANS: 2  
 $\left| \frac{13.5 - 12.8}{13.5} \right| \approx 0.093$
- PTS: 2 REF: 081123ia STA: A.M.3 TOP: Error  
 KEY: area
- 24 ANS: 2  
 $2000(1 + 0.04)^3 \approx 2249$
- PTS: 2 REF: 081124ia STA: A.A.9 TOP: Exponential Functions
- 25 ANS: 3  
 $P(O) = \frac{5}{10}, P(P) = \frac{4}{10}, P(\leq 5) = \frac{6}{10}, P(/3) = \frac{4}{10}$
- PTS: 2 REF: 081125ia STA: A.S.22 TOP: Theoretical Probability
- 26 ANS: 2  
 $\cos 38 = \frac{10}{x}$   
 $x = \frac{10}{\cos 38} \approx 12.69$
- PTS: 2 REF: 081126ia STA: A.A.44 TOP: Using Trigonometry to Find a Side
- 27 ANS: 2 PTS: 2 REF: 081127ia STA: A.A.40  
 TOP: Systems of Linear Inequalities
- 28 ANS: 1  
 $7 + 8 + 7 + \frac{12\pi}{2} = 22 + 6\pi$
- PTS: 2 REF: 081128ia STA: A.G.1 TOP: Compositions of Polygons and Circles  
 KEY: perimeter
- 29 ANS: 2  
 $36x^2 - 100y^6 = 4(9x^2 - 25y^6) = 4(3x + 5y^3)(3x - 5y^3)$
- PTS: 2 REF: 081129ia STA: A.A.19  
 TOP: Factoring the Difference of Perfect Squares

30 ANS: 4

$$\frac{x}{x+4} \div \frac{2x}{x^2-16} = \frac{x}{x+4} \cdot \frac{x^2-16}{2x} = \frac{1}{x+4} \cdot \frac{(x+4)(x-4)}{2} = \frac{x-4}{2}$$

PTS: 2

REF: 081130ia

STA: A.A.18

TOP: Multiplication and Division of Rationals

31 ANS:

$$bc + ac = ab$$

$$c(b+a) = ab$$

$$c = \frac{ab}{b+a}$$

PTS: 2

REF: 081131ia

STA: A.A.23

TOP: Transforming Formulas

32 ANS:

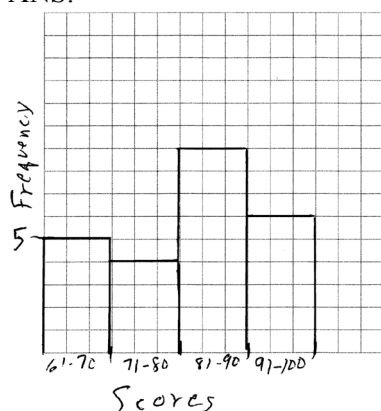

PTS: 2

REF: 081132ia

STA: A.S.5

TOP: Frequency Histograms, Bar Graphs and Tables

KEY: frequency histograms

33 ANS:

$$77120 + 33500 = 110620 \text{ sq. ft.} \times \frac{1 \text{ acre}}{43560 \text{ sq. ft.}} \approx 2.54 \text{ acres}$$

PTS: 2

REF: 081133ia

STA: A.M.2

TOP: Conversions

34 ANS:

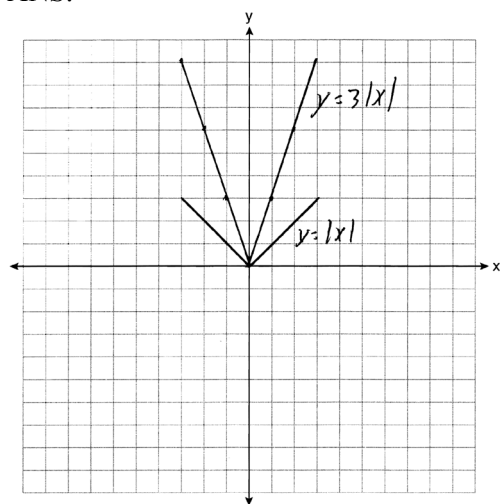

The graph becomes steeper.

PTS: 3

REF: 081134ia

STA: A.G.5

TOP: Graphing Absolute Value Functions

35 ANS:

$$41.8. \sin x = \frac{8}{12}$$

$$A \approx 41.8$$

PTS: 3

REF: 081135ia

STA: A.A.43

TOP: Using Trigonometry to Find an Angle

36 ANS:

$$-2\sqrt{3} \frac{16\sqrt{21}}{2\sqrt{7}} - 5\sqrt{12} = 8\sqrt{3} - 5\sqrt{4}\sqrt{3} = 8\sqrt{3} - 10\sqrt{3} = -2\sqrt{3}$$

PTS: 3

REF: 081136ia

STA: A.N.3

TOP: Operations with Radicals

37 ANS:

$$\frac{4}{12} \times \frac{2}{11} \times \frac{1}{10} = \frac{8}{1320} \quad \frac{6}{12} \times \frac{5}{11} \times \frac{4}{10} + \frac{4}{12} \times \frac{3}{11} \times \frac{2}{10} = \frac{120}{1320} + \frac{24}{1320} = \frac{144}{1320}$$

PTS: 4

REF: 081137ia

STA: A.S.23

TOP: Theoretical Probability

KEY: dependent events

38 ANS:

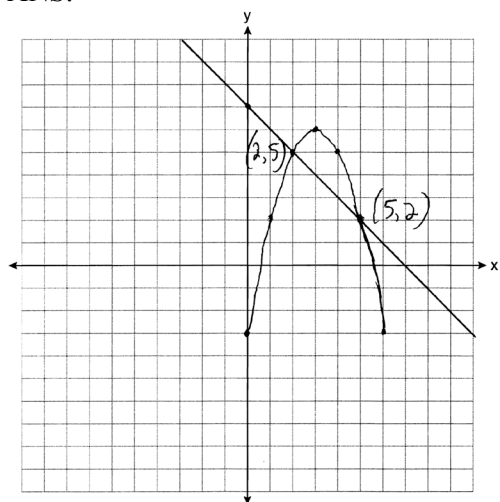

PTS: 4

REF: 081138ia

STA: A.G.9

TOP: Quadratic-Linear Systems

39 ANS:

$$\frac{m}{5} + \frac{3(m-1)}{2} = 2(m-3)$$

$$\frac{2m}{10} + \frac{15(m-1)}{10} = 2m - 6$$

$$\frac{17m-15}{10} = 2m-6$$

$$17m-15 = 20m-60$$

$$45 = 3m$$

$$15 = m$$

PTS: 4

REF: 081139ia

STA: A.A.25

TOP: Solving Equations with Fractional Expressions