

The University of the State of New York
REGENTS HIGH SCHOOL EXAMINATION

ALGEBRA 2/TRIGONOMETRY

Wednesday, June 18, 2014 — 1:15 to 4:15 p.m., only

Student Name: _____

School Name: _____

The possession or use of any communications device is strictly prohibited when taking this examination. If you have or use any communications device, no matter how briefly, your examination will be invalidated and no score will be calculated for you.

Print your name and the name of your school on the lines above.

A separate answer sheet for Part I has been provided to you. Follow the instructions from the proctor for completing the student information on your answer sheet.

This examination has four parts, with a total of 39 questions. You must answer all questions in this examination. Record your answers to the Part I multiple-choice questions on the separate answer sheet. Write your answers to the questions in Parts II, III, and IV directly in this booklet. All work should be written in pen, except for graphs and drawings, which should be done in pencil. Clearly indicate the necessary steps, including appropriate formula substitutions, diagrams, graphs, charts, etc.

The formulas that you may need to answer some questions in this examination are found at the end of the examination. This sheet is perforated so you may remove it from this booklet.

Scrap paper is not permitted for any part of this examination, but you may use the blank spaces in this booklet as scrap paper. A perforated sheet of scrap graph paper is provided at the end of this booklet for any question for which graphing may be helpful but is not required. You may remove this sheet from this booklet. Any work done on this sheet of scrap graph paper will *not* be scored.

When you have completed the examination, you must sign the statement printed at the end of the answer sheet, indicating that you had no unlawful knowledge of the questions or answers prior to the examination and that you have neither given nor received assistance in answering any of the questions during the examination. Your answer sheet cannot be accepted if you fail to sign this declaration.

Notice...

A graphing calculator and a straightedge (ruler) must be available for you to use while taking this examination.

DO NOT OPEN THIS EXAMINATION BOOKLET UNTIL THE SIGNAL IS GIVEN.

Part I

Answer all 27 questions in this part. Each correct answer will receive 2 credits. For each statement or question, choose the word or expression that, of those given, best completes the statement or answers the question. Record your answers on your separate answer sheet. [54]

Use this space for computations.

1 Which survey is *least* likely to contain bias?

- (1) surveying a sample of people leaving a movie theater to determine which flavor of ice cream is the most popular
- (2) surveying the members of a football team to determine the most watched TV sport
- (3) surveying a sample of people leaving a library to determine the average number of books a person reads in a year
- (4) surveying a sample of people leaving a gym to determine the average number of hours a person exercises per week

2 The expression $(2a)^{-4}$ is equivalent to

- (1) $-8a^4$
- (2) $\frac{16}{a^4}$
- (3) $-\frac{2}{a^4}$
- (4) $\frac{1}{16a^4}$

3 Two sides of a triangular-shaped sandbox measure 22 feet and 13 feet. If the angle between these two sides measures 55° , what is the area of the sandbox, to the *nearest square foot*?

- (1) 82
- (2) 117
- (3) 143
- (4) 234

4 Expressed in simplest form, $\sqrt{-18} - \sqrt{-32}$ is

- (1) $-\sqrt{2}$
- (2) $-7\sqrt{2}$
- (3) $-i\sqrt{2}$
- (4) $7i\sqrt{2}$

**Use this space for
computations.**

5 Theresa is comparing the graphs of $y = 2^x$ and $y = 5^x$. Which statement is true?

- (1) The y -intercept of $y = 2^x$ is $(0,2)$, and the y -intercept of $y = 5^x$ is $(0,5)$.
- (2) Both graphs have a y -intercept of $(0,1)$, and $y = 2^x$ is steeper.
- (3) Both graphs have a y -intercept of $(0,1)$, and $y = 5^x$ is steeper.
- (4) Neither graph has a y -intercept.

6 The solution set of the equation $\sqrt{2x - 4} = x - 2$ is

- (1) $\{-2, -4\}$
- (2) $\{2, 4\}$
- (3) $\{4\}$
- (4) $\{\}$

7 The expression $(2 - 3\sqrt{x})^2$ is equivalent to

- (1) $4 - 9x$
- (2) $4 - 3x$
- (3) $4 - 12\sqrt{x} + 9x$
- (4) $4 - 12\sqrt{x} + 6x$

8 Which step can be used when solving $x^2 - 6x - 25 = 0$ by completing the square?

- (1) $x^2 - 6x + 9 = 25 + 9$
- (2) $x^2 - 6x - 9 = 25 - 9$
- (3) $x^2 - 6x + 36 = 25 + 36$
- (4) $x^2 - 6x - 36 = 25 - 36$

Use this space for computations.

9 Which graph represents a function?

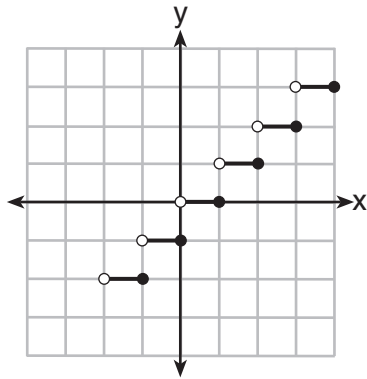

(1)

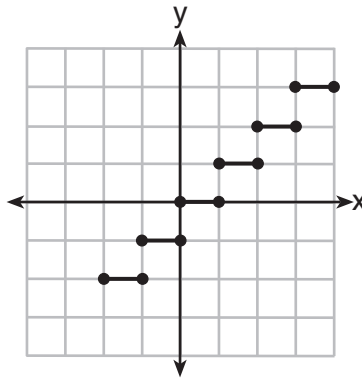

(3)

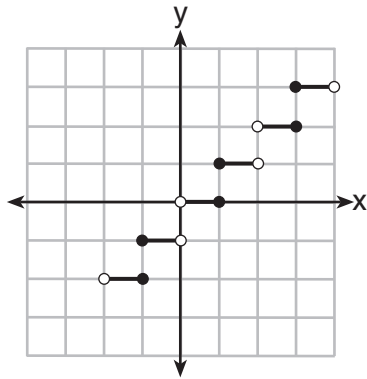

(2)

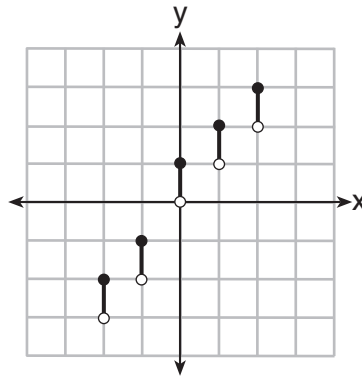

(4)

10 The expression $\frac{\cot x}{\csc x}$ is equivalent to

- (1) $\sin x$
- (2) $\cos x$
- (3) $\tan x$
- (4) $\sec x$

11 What is the common difference of the arithmetic sequence below?

$$-7x, -4x, -x, 2x, 5x, \dots$$

- (1) -3
- (2) $-3x$
- (3) 3
- (4) $3x$

**Use this space for
computations.**

12 If $\sin \theta < 0$ and $\cot \theta > 0$, in which quadrant does the terminal side of angle θ lie?

- (1) I (3) III
(2) II (4) IV

13 What is the period of the graph $y = \frac{1}{2} \sin 6x$?

- (1) $\frac{\pi}{6}$ (3) $\frac{\pi}{2}$
(2) $\frac{\pi}{3}$ (4) 6π

14 What is the product of the roots of the quadratic equation $2x^2 - 7x = 5$?

- (1) 5 (3) -5
(2) $\frac{5}{2}$ (4) $-\frac{5}{2}$

15 What is the equation of the circle passing through the point (6,5) and centered at (3,-4)?

- (1) $(x - 6)^2 + (y - 5)^2 = 82$
(2) $(x - 6)^2 + (y - 5)^2 = 90$
(3) $(x - 3)^2 + (y + 4)^2 = 82$
(4) $(x - 3)^2 + (y + 4)^2 = 90$

Use this space for computations.

16 The formula to determine continuously compounded interest is $A = Pe^{rt}$, where A is the amount of money in the account, P is the initial investment, r is the interest rate, and t is the time, in years. Which equation could be used to determine the value of an account with an \$18,000 initial investment, at an interest rate of 1.25% for 24 months?

- (1) $A = 18,000e^{1.25 \cdot 2}$ (3) $A = 18,000e^{0.0125 \cdot 2}$
(2) $A = 18,000e^{1.25 \cdot 24}$ (4) $A = 18,000e^{0.0125 \cdot 24}$

17 What is the solution set of the equation $\frac{30}{x^2 - 9} + 1 = \frac{5}{x - 3}$?

- (1) {2, 3} (3) {3}
(2) {2} (4) { }

18 The graph below shows the average price of gasoline, in dollars, for the years 1997 to 2007.

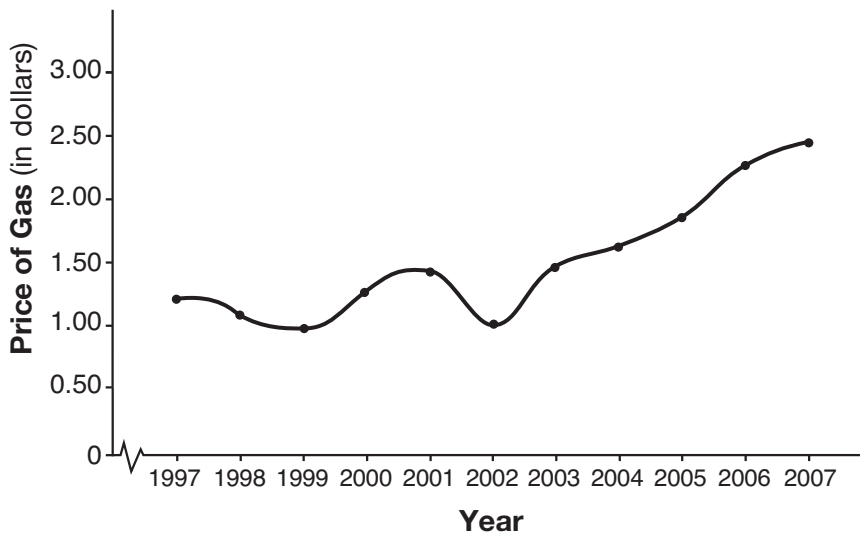

What is the approximate range of this graph?

- (1) $1997 \leq x \leq 2007$ (3) $0.97 \leq y \leq 2.38$
(2) $1999 \leq x \leq 2007$ (4) $1.27 \leq y \leq 2.38$

Use this space for
computations.

19 If $f(x) = 2x^2 - 3x + 1$ and $g(x) = x + 5$, what is $f(g(x))$?

(1) $2x^2 + 17x + 36$

(3) $2x^2 - 3x + 6$

(2) $2x^2 + 17x + 66$

(4) $2x^2 - 3x + 36$

20 A jogger ran $\frac{1}{3}$ mile on day 1, and $\frac{2}{3}$ mile on day 2, and $1\frac{1}{3}$ miles on day 3, and $2\frac{2}{3}$ miles on day 4, and this pattern continued for 3 more days. Which expression represents the total distance the jogger ran?

(1) $\sum_{d=1}^7 \frac{1}{3}(2)^{d-1}$

(3) $\sum_{d=1}^7 2\left(\frac{1}{3}\right)^{d-1}$

(2) $\sum_{d=1}^7 \frac{1}{3}(2)^d$

(4) $\sum_{d=1}^7 2\left(\frac{1}{3}\right)^d$

21 If $\sin x = \sin y = a$ and $\cos x = \cos y = b$, then $\cos(x - y)$ is equivalent to

(1) $b^2 - a^2$

(3) $2b - 2a$

(2) $b^2 + a^2$

(4) $2b + 2a$

22 A school math team consists of three juniors and five seniors. How many different groups can be formed that consist of one junior and two seniors?

(1) 13

(3) 30

(2) 15

(4) 60

23 For which value of k will the roots of the equation $2x^2 - 5x + k = 0$ be real and rational numbers?

(1) 1

(3) 0

(2) -5

(4) 4

**Use this space for
computations.**

24 A cliff diver on a Caribbean island jumps from a height of 105 feet, with an initial upward velocity of 5 feet per second. An equation that models the height, $h(t)$, above the water, in feet, of the diver in time elapsed, t , in seconds, is $h(t) = -16t^2 + 5t + 105$. How many seconds, to the *nearest hundredth*, does it take the diver to fall 45 feet below his starting point?

- (1) 1.45 (3) 2.10
(2) 1.84 (4) 2.72

25 The number of possible different 12-letter arrangements of the letters in the word “TRIGONOMETRY” is represented by

- (1) $\frac{12!}{3!}$ (3) $\frac{{}^{12}P_{12}}{8}$
(2) $\frac{12!}{6!}$ (4) $\frac{{}^{12}A_{12}}{6!}$

26 If $2x^3 = y$, then $\log y$ equals

- (1) $\log(2x) + \log 3$ (3) $3 \log 2 + 3 \log x$
(2) $3 \log(2x)$ (4) $\log 2 + 3 \log x$

27 Which statement regarding the inverse function is true?

- (1) A domain of $y = \sin^{-1} x$ is $[0, 2\pi]$.
(2) The range of $y = \sin^{-1} x$ is $[-1, 1]$.
(3) A domain of $y = \cos^{-1} x$ is $(-\infty, \infty)$.
(4) The range of $y = \cos^{-1} x$ is $[0, \pi]$.
-

Part II

Answer all 8 questions in this part. Each correct answer will receive 2 credits. Clearly indicate the necessary steps, including appropriate formula substitutions, diagrams, graphs, charts, etc. For all questions in this part, a correct numerical answer with no work shown will receive only 1 credit. All answers should be written in pen, except for graphs and drawings, which should be done in pencil. [16]

- 28 In a certain school, the heights of the population of girls are normally distributed, with a mean of 63 inches and a standard deviation of 2 inches. If there are 450 girls in the school, determine how many of the girls are *shorter than* 60 inches. Round the answer to the *nearest integer*.

29 The table below shows the concentration of ozone in Earth's atmosphere at different altitudes. Write the exponential regression equation that models these data, rounding *all* values to the nearest thousandth.

Concentration of Ozone

Altitude (x)	Ozone Units (y)
0	0.7
5	0.6
10	1.1
15	3.0
20	4.9

30 Solve $|2x - 3| > 5$ algebraically.

31 Convert 2.5 radians to degrees, and express the answer to the *nearest minute*.

32 Multiply $x + yi$ by its conjugate, and express the product in simplest form.

33 Solve algebraically for x :

$$\log_{5x-1} 4 = \frac{1}{3}$$

34 Solve $\sec x - \sqrt{2} = 0$ algebraically for all values of x in $0^\circ \leq x < 360^\circ$.

35 The function $f(x)$ is graphed on the set of axes below.

On the same set of axes, graph $f(x + 1) + 2$.

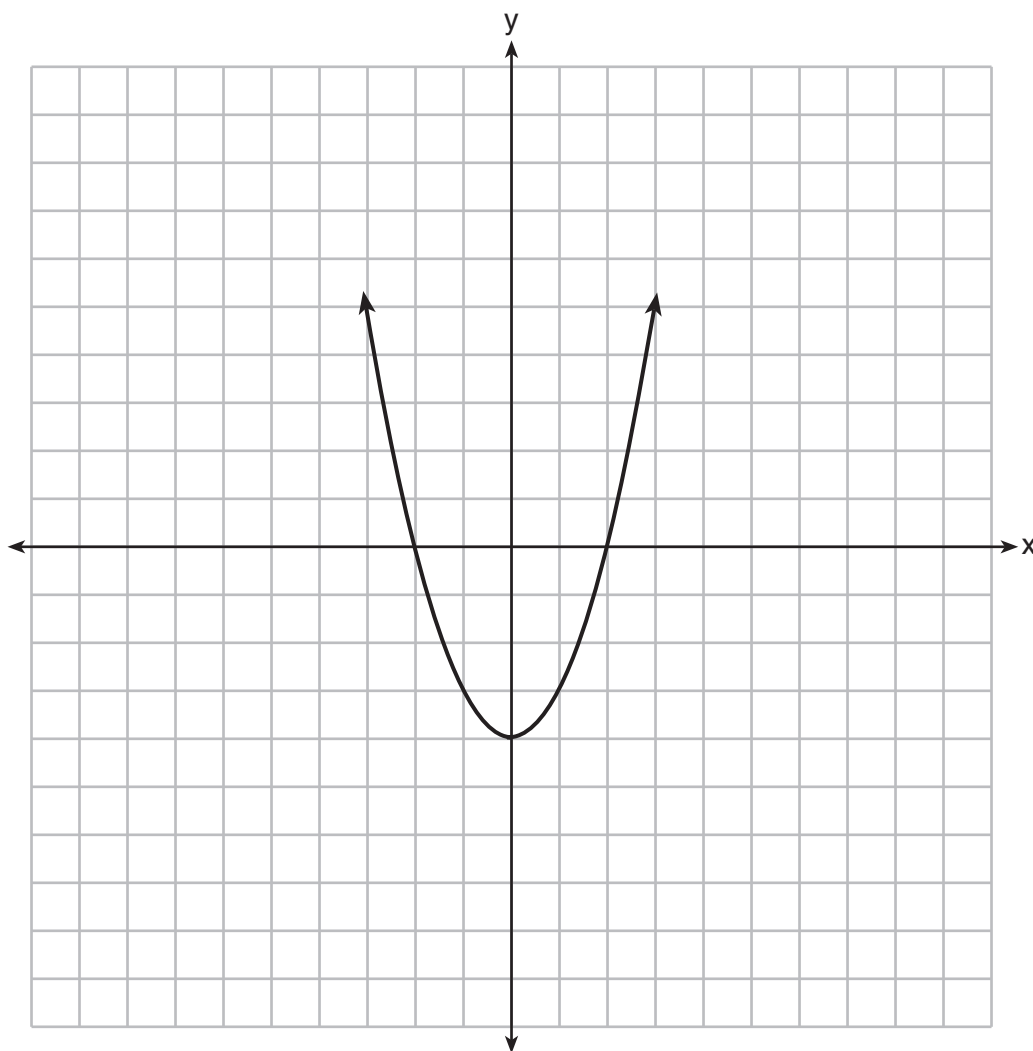

Part III

Answer all 3 questions in this part. Each correct answer will receive 4 credits. Clearly indicate the necessary steps, including appropriate formula substitutions, diagrams, graphs, charts, etc. For all questions in this part, a correct numerical answer with no work shown will receive only 1 credit. All answers should be written in pen, except for graphs and drawings, which should be done in pencil. [12]

36 Express in simplest terms:

$$\frac{1 + \frac{3}{x}}{1 - \frac{5}{x} - \frac{24}{x^2}}$$

37 Solve $x^3 + 5x^2 = 4x + 20$ algebraically.

38 Whenever Sara rents a movie, the probability that it is a horror movie is 0.57. Of the next five movies she rents, determine the probability, to the *nearest hundredth*, that *no more than* two of these rentals are horror movies.

Part IV

Answer the question in this part. A correct answer will receive 6 credits. Clearly indicate the necessary steps, including appropriate formula substitutions, diagrams, graphs, charts, etc. A correct numerical answer with no work shown will receive only 1 credit. The answer should be written in pen. [6]

- 39 Two forces of 40 pounds and 28 pounds act on an object. The angle between the two forces is 65° . Find the magnitude of the resultant force, to the *nearest pound*.
Using this answer, find the measure of the angle formed between the resultant and the *smaller* force, to the *nearest degree*.

Reference Sheet

Area of a Triangle

$$K = \frac{1}{2} ab \sin C$$

Functions of the Sum of Two Angles

$$\sin(A + B) = \sin A \cos B + \cos A \sin B$$

$$\cos(A + B) = \cos A \cos B - \sin A \sin B$$

$$\tan(A + B) = \frac{\tan A + \tan B}{1 - \tan A \tan B}$$

Functions of the Difference of Two Angles

$$\sin(A - B) = \sin A \cos B - \cos A \sin B$$

$$\cos(A - B) = \cos A \cos B + \sin A \sin B$$

$$\tan(A - B) = \frac{\tan A - \tan B}{1 + \tan A \tan B}$$

Law of Sines

$$\frac{a}{\sin A} = \frac{b}{\sin B} = \frac{c}{\sin C}$$

Sum of a Finite Arithmetic Series

$$S_n = \frac{n(a_1 + a_n)}{2}$$

Binomial Theorem

$$(a + b)^n = {}_n C_0 a^n b^0 + {}_n C_1 a^{n-1} b^1 + {}_n C_2 a^{n-2} b^2 + \dots + {}_n C_n a^0 b^n$$

$$(a + b)^n = \sum_{r=0}^n {}_n C_r a^{n-r} b^r$$

Law of Cosines

$$a^2 = b^2 + c^2 - 2bc \cos A$$

Functions of the Double Angle

$$\sin 2A = 2 \sin A \cos A$$

$$\cos 2A = \cos^2 A - \sin^2 A$$

$$\cos 2A = 2 \cos^2 A - 1$$

$$\cos 2A = 1 - 2 \sin^2 A$$

$$\tan 2A = \frac{2 \tan A}{1 - \tan^2 A}$$

Functions of the Half Angle

$$\sin \frac{1}{2} A = \pm \sqrt{\frac{1 - \cos A}{2}}$$

$$\cos \frac{1}{2} A = \pm \sqrt{\frac{1 + \cos A}{2}}$$

$$\tan \frac{1}{2} A = \pm \sqrt{\frac{1 - \cos A}{1 + \cos A}}$$

Sum of a Finite Geometric Series

$$S_n = \frac{a_1(1 - r^n)}{1 - r}$$

Normal Curve Standard Deviation

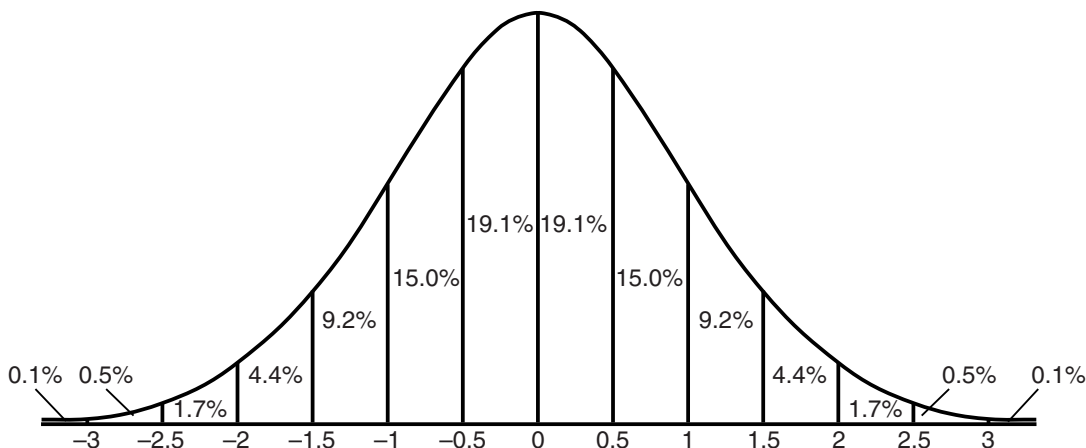

Tear Here

Tear Here

Scrap Graph Paper – This sheet will *not* be scored.

Tear Here

Tear Here

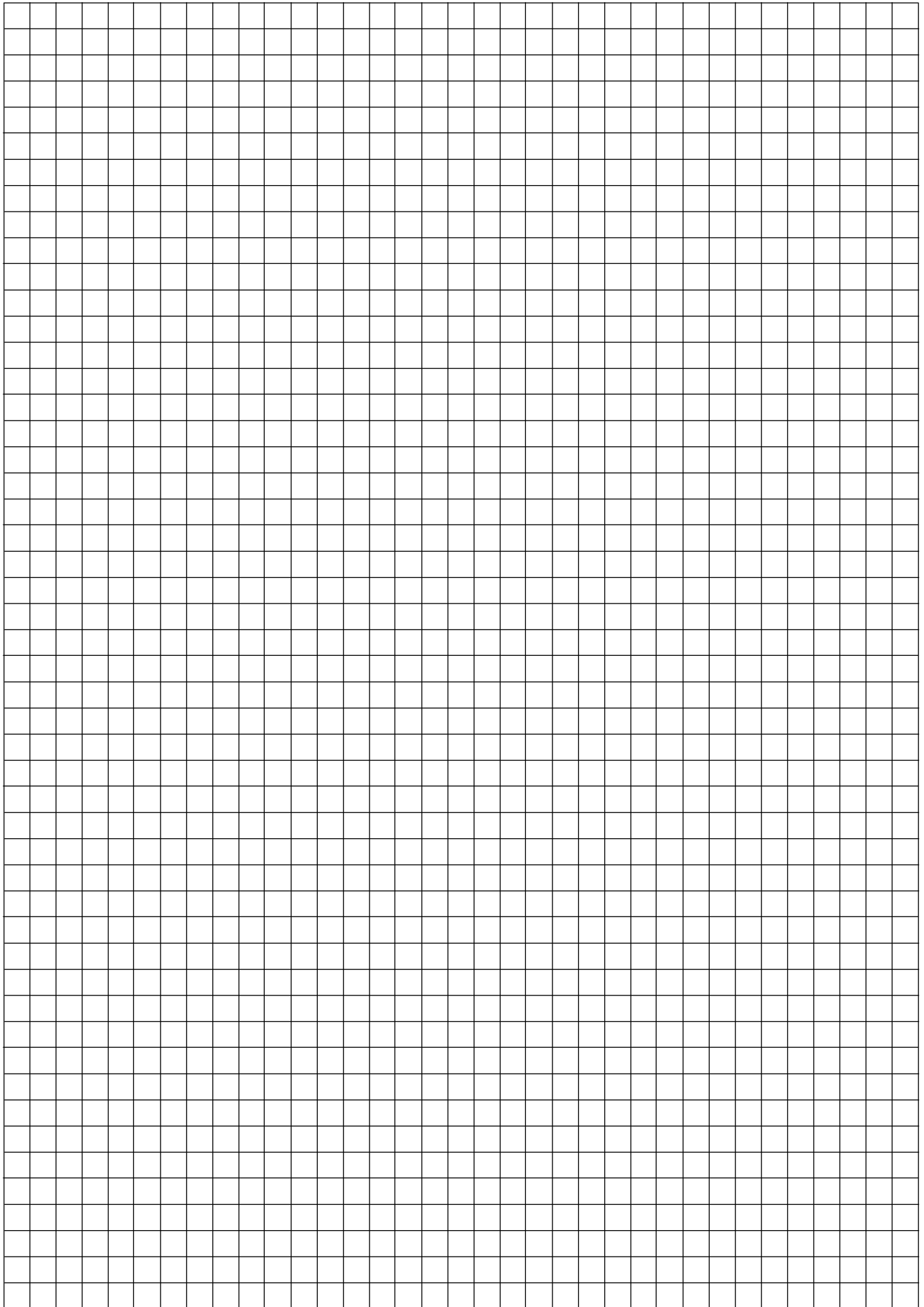

Scrap Graph Paper — This sheet will *not* be scored.

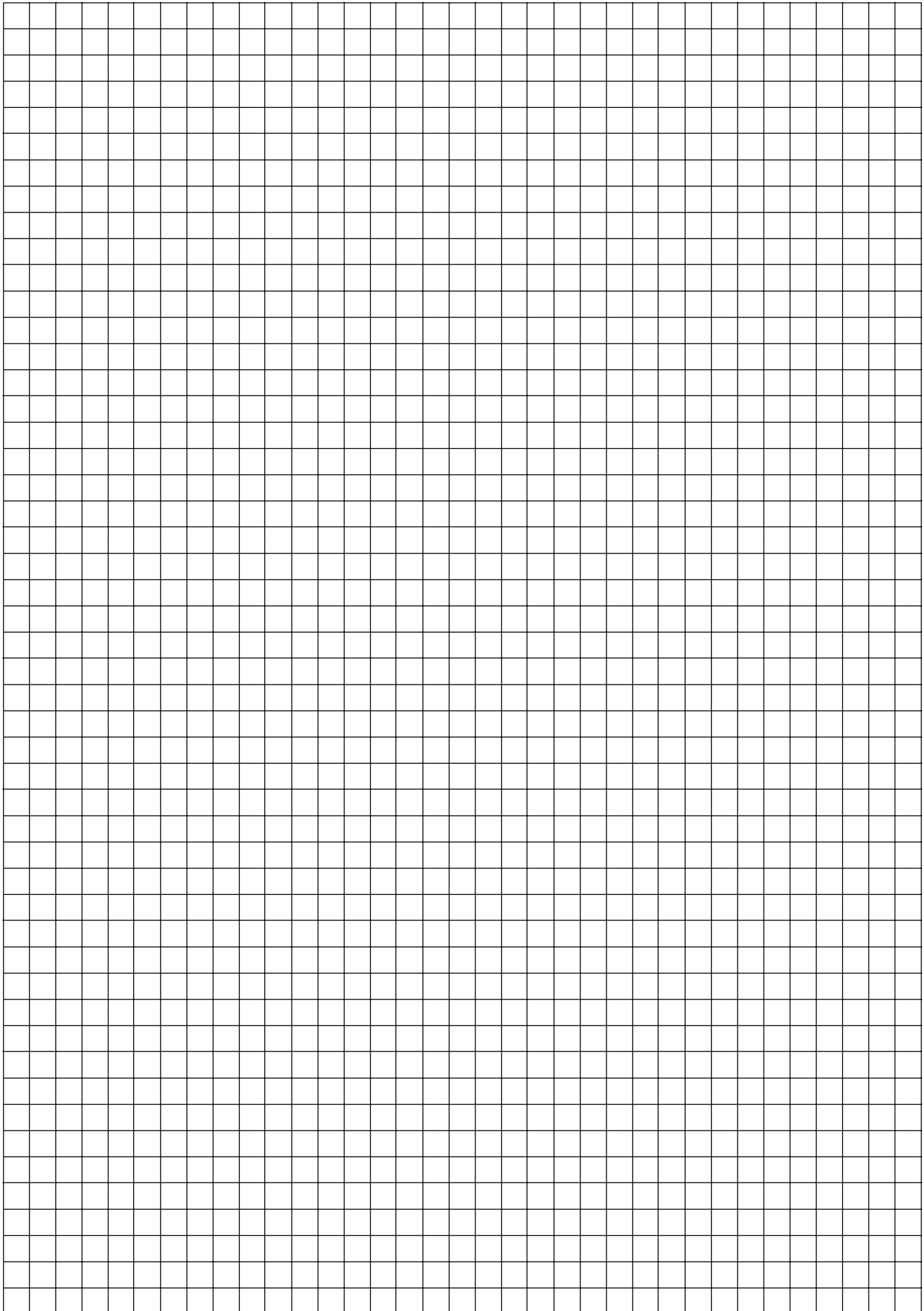

Tear Here

Tear Here

FOR TEACHERS ONLY

The University of the State of New York

REGENTS HIGH SCHOOL EXAMINATION

ALGEBRA 2/TRIGONOMETRY

Wednesday, June 18, 2014 — 1:15 to 4:15 p.m., only

SCORING KEY AND RATING GUIDE

Mechanics of Rating

The following procedures are to be followed for scoring student answer papers for the Regents Examination in Algebra 2/Trigonometry. More detailed information about scoring is provided in the publication *Information Booklet for Scoring the Regents Examinations in Mathematics*.

Do *not* attempt to correct the student's work by making insertions or changes of any kind. In scoring the open-ended questions, use check marks to indicate student errors. Unless otherwise specified, mathematically correct variations in the answers will be allowed. Units need not be given when the wording of the questions allows such omissions.

Each student's answer paper is to be scored by a minimum of three mathematics teachers. No one teacher is to score more than approximately one-third of the open-ended questions on a student's paper. Teachers may not score their own students' answer papers. On the student's separate answer sheet, for each question, record the number of credits earned and the teacher's assigned rater/scorer letter.

Schools are not permitted to rescore any of the open-ended questions on this exam after each question has been rated once, regardless of the final exam score. Schools are required to ensure that the raw scores have been added correctly and that the resulting scale score has been determined accurately.

Raters should record the student's scores for all questions and the total raw score on the student's separate answer sheet. Then the student's total raw score should be converted to a scale score by using the conversion chart that will be posted on the Department's web site at: <http://www.p12.nysed.gov/assessment/> on Wednesday, June 18, 2014. Because scale scores corresponding to raw scores in the conversion chart may change from one administration to another, it is crucial that, for each administration, the conversion chart provided for that administration be used to determine the student's final score. The student's scale score should be entered in the box provided on the student's separate answer sheet. The scale score is the student's final examination score.

If the student's responses for the multiple-choice questions are being hand scored prior to being scanned, the scorer must be careful not to make any marks on the answer sheet except to record the scores in the designated score boxes. Marks elsewhere on the answer sheet will interfere with the accuracy of the scanning.

Part I

Allow a total of 54 credits, 2 credits for each of the following.

(1) 1	(10) 2	(19) 1
(2) 4	(11) 4	(20) 1
(3) 2	(12) 3	(21) 2
(4) 3	(13) 2	(22) 3
(5) 3	(14) 4	(23) 3
(6) 2	(15) 4	(24) 2
(7) 3	(16) 3	(25) 3
(8) 1	(17) 2	(26) 4
(9) 1	(18) 3	(27) 4

Updated information regarding the rating of this examination may be posted on the New York State Education Department's web site during the rating period. Check this web site at: <http://www.p12.nysed.gov/assessment/> and select the link "Scoring Information" for any recently posted information regarding this examination. This site should be checked before the rating process for this examination begins and several times throughout the Regents Examination period.

Beginning in June 2013, the Department is providing supplemental scoring guidance, the "Sample Response Set," for the Regents Examination in Algebra 2/Trigonometry. This guidance is not required as part of the scorer training. It is at the school's discretion to incorporate it into the scorer training or to use it as supplemental information during scoring. While not reflective of all scenarios, the sample student responses selected for the Sample Response Set illustrate how less common student responses to open-ended questions may be scored. The Sample Response Set will be available on the Department's web site at: <http://www.nysedregents.org/a2trig/home.html>.

General Rules for Applying Mathematics Rubrics

I. General Principles for Rating

The rubrics for the constructed-response questions on the Regents Examination in Algebra 2/Trigonometry are designed to provide a systematic, consistent method for awarding credit. The rubrics are not to be considered all-inclusive; it is impossible to anticipate all the different methods that students might use to solve a given problem. Each response must be rated carefully using the teacher's professional judgment and knowledge of mathematics; all calculations must be checked. The specific rubrics for each question must be applied consistently to all responses. In cases that are not specifically addressed in the rubrics, raters must follow the general rating guidelines in the publication *Information Booklet for Scoring the Regents Examinations in Mathematics*, use their own professional judgment, confer with other mathematics teachers, and/or contact the State Education Department for guidance. During each Regents Examination administration period, rating questions may be referred directly to the Education Department. The contact numbers are sent to all schools before each administration period.

II. Full-Credit Responses

A full-credit response provides a complete and correct answer to all parts of the question. Sufficient work is shown to enable the rater to determine how the student arrived at the correct answer.

When the rubric for the full-credit response includes one or more examples of an acceptable method for solving the question (usually introduced by the phrase “such as”), it does not mean that there are no additional acceptable methods of arriving at the correct answer. Unless otherwise specified, mathematically correct alternative solutions should be awarded credit. The only exceptions are those questions that specify the type of solution that must be used; e.g., an algebraic solution or a graphic solution. A correct solution using a method other than the one specified is awarded half the credit of a correct solution using the specified method.

III. Appropriate Work

Full-Credit Responses: The directions in the examination booklet for all the constructed-response questions state: “Clearly indicate the necessary steps, including appropriate formula substitutions, diagrams, graphs, charts, etc.” The student has the responsibility of providing the correct answer **and** showing how that answer was obtained. The student must “construct” the response; the teacher should not have to search through a group of seemingly random calculations scribbled on the student paper to ascertain what method the student may have used.

Responses With Errors: Rubrics that state “Appropriate work is shown, but...” are intended to be used with solutions that show an essentially complete response to the question but contain certain types of errors, whether computational, rounding, graphing, or conceptual. If the response is incomplete; i.e., an equation is written but not solved or an equation is solved but not all of the parts of the question are answered, appropriate work has **not** been shown. Other rubrics address incomplete responses.

IV. Multiple Errors

Computational Errors, Graphing Errors, and Rounding Errors: Each of these types of errors results in a 1-credit deduction. Any combination of two of these types of errors results in a 2-credit deduction. No more than 2 credits should be deducted for such mechanical errors in any response. The teacher must carefully review the student's work to determine what errors were made and what type of errors they were.

Conceptual Errors: A conceptual error involves a more serious lack of knowledge or procedure. Examples of conceptual errors include using the incorrect formula for the area of a figure, choosing the incorrect trigonometric function, or multiplying the exponents instead of adding them when multiplying terms with exponents. A response with one conceptual error can receive no more than half credit.

If a response shows repeated occurrences of the same conceptual error, the student should not be penalized twice. If the same conceptual error is repeated in responses to other questions, credit should be deducted in each response.

If a response shows one conceptual error and one computational, graphing, or rounding error, the teacher must award credit that takes into account both errors; i.e., awarding half credit for the conceptual error and deducting 1 credit for each mechanical error (maximum of two deductions for mechanical errors).

Part II

For each question, use the specific criteria to award a maximum of 2 credits. Unless otherwise specified, mathematically correct alternative solutions should be awarded appropriate credit.

(28) [2] 30, and correct work is shown.

[1] Appropriate work is shown, but one computational or rounding error is made.

or

[1] Appropriate work is shown, but one conceptual error is made.

or

[1] 30, but no work is shown.

[0] A zero response is completely incorrect, irrelevant, or incoherent or is a correct response that was obtained by an obviously incorrect procedure.

(29) [2] $y = 0.488(1.116)^x$

[1] One rounding error is made.

or

[1] The expression $0.488(1.116)^x$ is written.

or

[1] An incorrect exponential regression equation is written.

[0] A regression equation other than exponential is written.

or

[0] A zero response is completely incorrect, irrelevant, or incoherent or is a correct response that was obtained by an obviously incorrect procedure.

(30) [2] " $x > 4$ or $x < -1$ " or an equivalent disjunction, and correct algebraic work is shown.

[1] Appropriate work is shown, but one computational error is made.

or

[1] Appropriate work is shown, but one conceptual error is made.

or

[1] Appropriate work is shown to find either $x > 4$ or $x < -1$.

or

[1] Appropriate work is shown, but the answer is not expressed as a disjunction.

or

[1] " $x > 4$ or $x < -1$," but a method other than algebraic is used.

or

[1] " $x > 4$ or $x < -1$," but no work is shown.

[0] A zero response is completely incorrect, irrelevant, or incoherent or is a correct response that was obtained by an obviously incorrect procedure.

(31) [2] $143^{\circ}14'$, and correct work is shown.

[1] Appropriate work is shown, but one computational or rounding error is made.

or

[1] Appropriate work is shown, but one conceptual error is made.

or

[1] $143^{\circ}14'$, but no work is shown.

[0] A zero response is completely incorrect, irrelevant, or incoherent or is a correct response that was obtained by an obviously incorrect procedure.

(32) [2] $x^2 + y^2$, and correct work is shown.

[1] Appropriate work is shown, but one computational or simplification error is made.

or

[1] Appropriate work is shown, but one conceptual error is made.

or

[1] The conjugate, $x - yi$, is written, but no further correct work is shown.

or

[1] $x^2 + y^2$, but no work is shown.

[0] A zero response is completely incorrect, irrelevant, or incoherent or is a correct response that was obtained by an obviously incorrect procedure.

(33) [2] 13, and correct algebraic work is shown.

[1] Appropriate work is shown, but one computational error is made.

or

[1] Appropriate work is shown, but one conceptual error is made.

or

[1] $(5x - 1)^{\frac{1}{3}} = 4$ is written, but no further correct work is shown.

or

[1] 13, but a method other than algebraic is used.

or

[1] 13, but no work is shown.

[0] A zero response is completely incorrect, irrelevant, or incoherent or is a correct response that was obtained by an obviously incorrect procedure.

- (34) [2] 45 and 315, and correct algebraic work is shown.
- [1] Appropriate work is shown, but one computational error is made.
- or***
- [1] Appropriate work is shown, but one conceptual error is made.
- or***
- [1] Appropriate work is shown to find one solution, but no further correct work is shown.
- or***
- [1] 45 and 315, but a method other than algebraic is used.
- or***
- [1] 45 and 315, but no work is shown.
- [0] A zero response is completely incorrect, irrelevant, or incoherent or is a correct response that was obtained by an obviously incorrect procedure.
- (35) [2] A correct graph is drawn.
- [1] Appropriate work is shown, but one graphing error is made.
- or***
- [1] Appropriate work is shown, but one conceptual error is made, such as translating 1 unit to the right.
- [0] A zero response is completely incorrect, irrelevant, or incoherent or is a correct response that was obtained by an obviously incorrect procedure.
-

Part III

For each question, use the specific criteria to award a maximum of 4 credits. Unless otherwise specified, mathematically correct alternative solutions should be awarded appropriate credit.

(36) [4] $\frac{x}{x-8}$, and correct work is shown.

[3] Appropriate work is shown, but one computational, factoring, or simplification error is made.

[2] Appropriate work is shown, but two or more computational, factoring, or simplification errors are made.

or

[2] Appropriate work is shown, but one conceptual error is made.

or

[2] $\frac{x^2 + 3x}{x^2 - 5x - 24}$ or $\frac{x(x + 3)}{x^2 - 5x - 24}$ is written, but no further correct work is shown.

[1] Appropriate work is shown, but one conceptual error and one computational, factoring, or simplification error are made.

or

[1] $\frac{x}{x-8}$, but no work is shown.

[0] A zero response is completely incorrect, irrelevant, or incoherent or is a correct response that was obtained by an obviously incorrect procedure.

- (37) [4] ± 2 and -5 , and correct algebraic work is shown.
- [3] Appropriate work is shown, but one computational or factoring error is made.
- [2] Appropriate work is shown, but two or more computational or factoring errors are made.
- or***
- [2] Appropriate work is shown, but one conceptual error is made.
- or***
- [2] $(x^2 - 4)(x + 5) = 0$ is written, but no further correct work is shown.
- or***
- [2] ± 2 and -5 , but a method other than algebraic is used.
- [1] Appropriate work is shown, but one conceptual error and one computational or factoring error are made.
- or***
- [1] $x^2(x + 5) - 4(x + 5) = 0$ is written, but no further correct work is shown.
- or***
- [1] ± 2 and -5 , but no work is shown.
- [0] A zero response is completely incorrect, irrelevant, or incoherent or is a correct response that was obtained by an obviously incorrect procedure.

- (38) [4] 0.37, and correct work is shown.
- [3] Appropriate work is shown, but one computational or rounding error is made.
- or**
- [3] The three individual probabilities are calculated correctly, but their sum is not found.
- [2] Appropriate work is shown, but two or more computational or rounding errors are made.
- or**
- [2] Appropriate work is shown, but one conceptual error is made, such as finding 0.89, the probability of “no less than.”
- or**
- [2] The expression ${}_5C_0(0.57)^0(0.43)^5 + {}_5C_1(0.57)^1(0.43)^4 + {}_5C_2(0.57)^2(0.43)^3$ is written, but no further correct work is shown.
- [1] Appropriate work is shown, but one conceptual error and one computational or rounding error are made.
- or**
- [1] Appropriate work is shown to find 0.26, the probability of exactly two movies.
- or**
- [1] 0.37, but no work is shown.
- [0] A zero response is completely incorrect, irrelevant, or incoherent or is a correct response that was obtained by an obviously incorrect procedure.
-

Part IV

For this question, use the specific criteria to award a maximum of 6 credits. Unless otherwise specified, mathematically correct alternative solutions should be awarded appropriate credit.

(39) [6] 58 and 39, and correct work is shown.

or

[6] 58 and 38, and correct work is shown using the Law of Cosines to find the measure of the angle.

[5] Appropriate work is shown, but one computational or rounding error is made.

[4] Appropriate work is shown, but two computational or rounding errors are made.

or

[4] Appropriate work is shown, but one conceptual error is made.

or

[4] Appropriate work is shown to find 58, the magnitude of the resultant, but no further correct work is shown.

[3] Appropriate work is shown, but three or more computational or rounding errors are made.

or

[3] Appropriate work is shown, but one conceptual error and one computational or rounding error are made.

[2] Appropriate work is shown, but one conceptual error and two or more computational or rounding errors are made.

or

[2] Appropriate work is shown, but two conceptual errors are made.

or

[2] A correct substitution is made into the Law of Cosines, but no further correct work is shown.

or

[2] 58 and 39, but no work is shown.

The rubric for question 39 is continued on the next page.

[1] Appropriate work is shown, but two conceptual errors and one computational or rounding error are made.

or

[1] A complete and correctly labeled diagram is drawn to illustrate the problem, but no further correct work is shown.

or

[1] 58, but no work is shown.

[0] A zero response is completely incorrect, irrelevant, or incoherent or is a correct response that was obtained by an obviously incorrect procedure.

Map to Core Curriculum

Content Strands	Item Numbers
Number Sense and Operations	4, 7, 32
Algebra	2, 3, 5, 6, 8, 9, 10, 11, 12, 13, 14, 15, 16, 17, 18, 19, 20, 21, 23, 24, 26, 27, 30, 33, 34, 35, 36, 37, 39
Measurement	31
Statistics and Probability	1, 22, 25, 28, 29, 38

Regents Examination in Algebra 2/Trigonometry June 2014

Chart for Converting Total Test Raw Scores to Final Examination Scores (Scale Scores)

The *Chart for Determining the Final Examination Score for the June 2014 Regents Examination in Algebra 2/Trigonometry* will be posted on the Department's web site at: <http://www.p12.nysed.gov/assessment/> on Wednesday, June 18, 2014. Conversion charts provided for previous administrations of the Regents Examination in Algebra 2/Trigonometry must NOT be used to determine students' final scores for this administration.

Online Submission of Teacher Evaluations of the Test to the Department

Suggestions and feedback from teachers provide an important contribution to the test development process. The Department provides an online evaluation form for State assessments. It contains spaces for teachers to respond to several specific questions and to make suggestions. Instructions for completing the evaluation form are as follows:

1. Go to <http://www.forms2.nysed.gov/emsc/osa/exameval/reexameval.cfm>.
2. Select the test title.
3. Complete the required demographic fields.
4. Complete each evaluation question and provide comments in the space provided.
5. Click the SUBMIT button at the bottom of the page to submit the completed form.

The University of the State of New York
THE STATE EDUCATION DEPARTMENT
Office of State Assessment
Albany, New York 12234

IMPORTANT NOTICE

Regents Examination in Algebra 2/Trigonometry Wednesday, June 18, 2014, 1:15 p.m. Question 5, only

This notice applies to the scoring of multiple-choice Question 5 of the Regents Examination in Algebra 2/Trigonometry.

Because no domain was specified for this question, either choice 3, the correct answer indicated in the Scoring Key, or choice 2 should be accepted as a correct answer and awarded 2 credits.

Please photocopy this notice and give a copy of it to each teacher scoring the Regents Examination in Algebra 2/Trigonometry.

We apologize for any inconvenience this may cause you, and we thank you for your hard work on behalf of the students in New York State.

The University of the State of New York
REGENTS HIGH SCHOOL EXAMINATION

ALGEBRA 2/ TRIGONOMETRY

Wednesday, June 18, 2014 — 1:15 – 4:15 p.m.

SAMPLE RESPONSE SET

Table of Contents

Question 28	2
Question 29	6
Question 30	11
Question 31	19
Question 32	22
Question 33	25
Question 34	30
Question 35	34
Question 36	37
Question 37	42
Question 38	48
Question 39	55

Question 28

28 In a certain school, the heights of the population of girls are normally distributed, with a mean of 63 inches and a standard deviation of 2 inches. If there are 450 girls in the school, determine how many of the girls are *shorter than* 60 inches. Round the answer to the *nearest integer*.

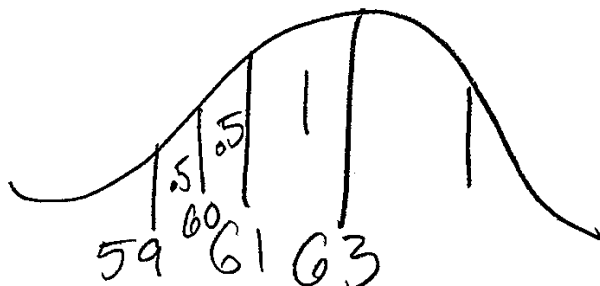

30

$$4.4 + 1.7 + 0.5 + 0.1$$

$$2.03$$
$$6.7\%$$

$$0.067 \times 450$$

Score 2: The student has a complete and correct response.

Question 28

28 In a certain school, the heights of the population of girls are normally distributed, with a mean of 63 inches and a standard deviation of 2 inches. If there are 450 girls in the school, determine how many of the girls are *shorter than* 60 inches. Round the answer to the *nearest integer*.

$$\text{norm Cdf}(9E-99, 60, 63, 2) = 0.0668$$

$$(0.0668)(450) = 30.06$$

$$\approx \underline{\underline{30}}$$

Score 2: The student has a complete and correct response.

Question 28

28 In a certain school, the heights of the population of girls are normally distributed, with a mean of 63 inches and a standard deviation of 2 inches. If there are 450 girls in the school, determine how many of the girls are *shorter than* 60 inches. Round the answer to the *nearest integer*.

$$\begin{array}{r} 34.1\% \\ 57 \leftarrow 59 \leftarrow 61 \leftarrow \frac{63}{\bar{x}} \\ 9.2\% \\ 4.4\% \\ 1.7\% \\ .5\% \\ + .1\% \\ \hline 6.7\% \end{array}$$

Score 1: The student made one conceptual error by finding the percentage of girls shorter than 60 inches, but not how many girls.

Question 28

28 In a certain school, the heights of the population of girls are normally distributed, with a mean of 63 inches and a standard deviation of 2 inches. If there are 450 girls in the school, determine how many of the girls are *shorter than* 60 inches. Round the answer to the *nearest integer*.

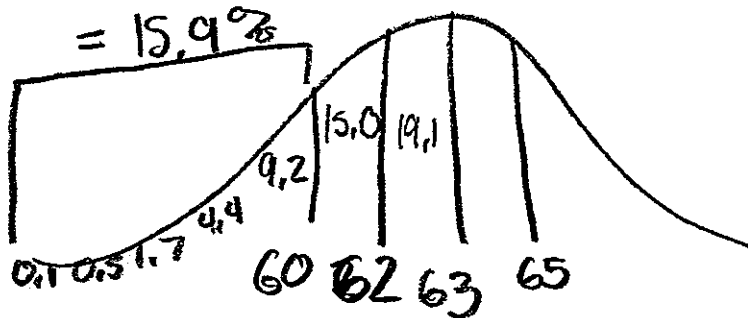

$$15.9\% \text{ of } 450$$

$$\frac{x}{450} = \frac{15.9}{100}$$

$$100x = 6930$$

$$x = 69.30$$

$$\approx 69 \text{ girls}$$

Score 0: The student made one conceptual error and one computational error.

Question 29

29 The table below shows the concentration of ozone in Earth's atmosphere at different altitudes. Write the exponential regression equation that models these data, rounding *all* values to the nearest thousandth.

Concentration of Ozone

Altitude (x)	Ozone Units (y)
0	0.7
5	0.6
10	1.1
15	3.0
20	4.9

$$y = 0.488 \cdot 1.116^x$$

Score 2: The student has a complete and correct response.

Question 29

29 The table below shows the concentration of ozone in Earth's atmosphere at different altitudes. Write the exponential regression equation that models these data, rounding *all* values to the nearest thousandth.

Concentration of Ozone

Altitude (x)	Ozone Units (y)
0	0.7
5	0.6
10	1.1
15	3.0
20	4.9

$$y = a \cdot b^x$$
$$a = .4881560152$$
$$b = 1.116306161$$
$$r^2 = .8911842707$$
$$r = .9440255667$$

$$y = a \cdot b^x$$
$$y = .488 \cdot 1.116^x$$

Score 2: The student has a complete and correct response.

Question 29

29 The table below shows the concentration of ozone in Earth's atmosphere at different altitudes. Write the exponential regression equation that models these data, rounding *all* values to the nearest thousandth.

Concentration of Ozone

Altitude (x)	Ozone Units (y)
0	0.7
5	0.6
10	1.1
15	3.0
20	4.9

$$a = .49$$
$$b = 1.12$$

$$r^2 = .89$$

$$r = .94$$

$$y = (a)(b)^x$$

Score 1: The student made one rounding error.

Question 29

29 The table below shows the concentration of ozone in Earth's atmosphere at different altitudes. Write the exponential regression equation that models these data, rounding *all* values to the nearest thousandth.

Concentration of Ozone

Altitude (x)	Ozone Units (y)
0	0.7
5	0.6
10	1.1
15	3.0
20	4.9

$$a = .4881560152$$

$$b = 1.1163061161$$

$$.488 \cdot 1.116^x$$

Score 1: The student wrote an exponential regression expression.

Question 29

29 The table below shows the concentration of ozone in Earth's atmosphere at different altitudes. Write the exponential regression equation that models these data, rounding *all* values to the nearest thousandth.

Concentration of Ozone

Altitude (x)	Ozone Units (y)
0	0.7
5	0.6
10	1.1
15	3.0
20	4.9

$$a = .49$$
$$b = 1.12$$
$$r^2 = .89$$
$$r = .94$$

Score 0: The student made one rounding error and did not write an exponential regression equation.

Question 30

30 Solve $|2x - 3| > 5$ algebraically.

$$2x - 3 > 5 \quad 2x - 3 < -5$$

$$2x > 8 \quad 2x < -2$$

$$\boxed{x > 4 \quad \text{or} \quad x < -1}$$

Score 2: The student has a complete and correct response.

Question 30

30 Solve $|2x - 3| > 5$ algebraically.

$$\begin{array}{l} / \quad \backslash \\ 2x - 3 = 5 \quad -2x + 3 = -5 \\ +3 \quad +3 \quad \quad -3 \quad -3 \\ \hline 2x = 8 \quad \quad -2x = -2 \\ \frac{2x}{2} = \frac{8}{2} \quad \quad \frac{-2x}{-2} = \frac{-2}{-2} \\ x = 4 \quad \quad x = -1 \end{array}$$

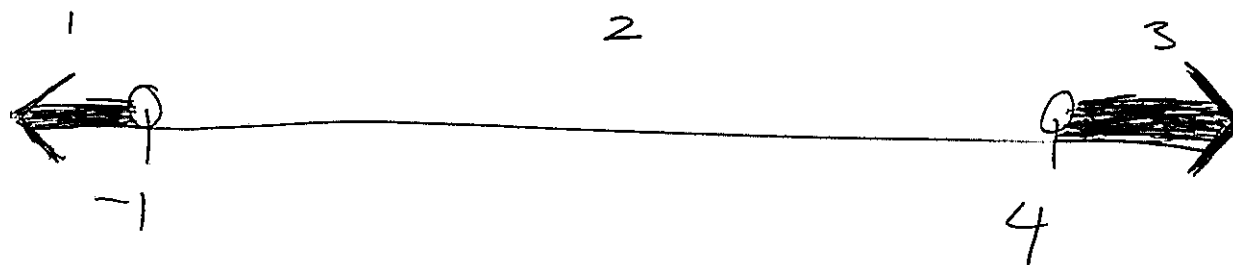

- 1: -2 T
- 2: 0 F
- 3: 5 T

$$\boxed{\{x \mid (x < -1) \vee (x > 4)\}}$$

Score 2: The student has a complete and correct response.

Question 30

30 Solve $|2x - 3| > 5$ algebraically.

$$2x - 3 > 5$$

$$2x > 8$$

$$x > 4$$

$$2x - 3 < -5$$

$$2x < -2$$

$$x < -1$$



Score 2: The student has a complete and correct response.

Question 30

30 Solve $|2x - 3| > 5$ algebraically.

$$2x - 3 > 5$$

$$2x > 8$$

$$x > 4$$

$$2x - 3 < -5$$

$$2x < -2$$

$$x < -1$$

Score 1: The student did not express the answer as a disjunction.

Question 30

30 Solve $|2x - 3| > 5$ algebraically.

$$\begin{array}{l} 2x - 3 > 5 \\ +3 \quad +3 \end{array}$$

$$\begin{array}{l} 2x + 3 < -5 \\ -3 \quad -3 \end{array}$$

$$\frac{2x > 8}{2}$$

$$x > 4$$

or

$$\frac{2x < -8}{2}$$

$$x < -4$$

Score 1: The student made one computational (copy) error.

Question 30

30 Solve $|2x - 3| > 5$ algebraically.

$$-2x + 3 > 5$$

$$-2x > 2$$

$$x < -1$$

Score 1: The student showed appropriate work to find $x < -1$, only.

Question 30

30 Solve $|2x - 3| > 5$ algebraically.

$$\begin{array}{l} -2x - 3 > 5 \\ \underline{-5} \\ -2x > 8 \\ \underline{-2} \\ x > 4 \end{array}$$

Score 0: The student made one conceptual error and one computational error.

Question 30

30 Solve $|2x - 3| > 5$ algebraically.

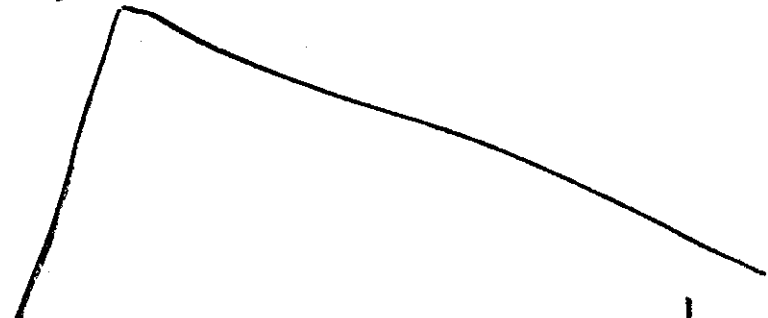
$$|2x - 3| > 5$$

$$\begin{array}{l} |2x - 3| > 5 \\ \hline \begin{array}{l} +3 \\ +3 \end{array} \end{array}$$
$$\frac{|2x|}{2} > \frac{8}{2}$$
$$x > 4$$
$$\begin{array}{l} |2x + 3| > 5 \\ \hline \begin{array}{l} -3 \\ -3 \end{array} \end{array}$$
$$\frac{|2x|}{2} > \frac{2}{2}$$
$$x > 1$$
$$\{1, 4\}$$

Score 0: The student made multiple conceptual errors.

Question 31

31 Convert 2.5 radians to degrees, and express the answer to the *nearest minute*.

$$\frac{2.5}{1} \cdot \frac{180}{\pi} = \frac{450}{\pi}$$

$$143^{\circ} 14'$$

Score 2: The student has a complete and correct response.

Question 31

31 Convert 2.5 radians to degrees, and express the answer to the *nearest minute*.

$$2.5 \left(\frac{180}{\pi} \right) = 143.2394488 = 143^\circ$$

Score 1: The student made one conceptual error by not expressing the answer to the nearest minute.

Question 31

31 Convert 2.5 radians to degrees, and express the answer to the *nearest minute*.

$$2.5\pi \cdot \frac{180}{\pi}$$

$$1.5 \cdot 180 = 270$$

Score 0: The student made one conceptual error and one computational error.

Question 32

32 Multiply $x + yi$ by its conjugate, and express the product in simplest form.

$$(x + yi)(x - yi)$$

$$x^2 - xyi + xyi - y^2i^2$$

$$x^2 - \cancel{xyi} + \cancel{xyi}$$

$$x^2 - y^2(-1)$$

$$\boxed{x^2 + y^2}$$

$$\begin{array}{c} +i \\ \hline -1 \\ \hline -i \\ +1 \end{array}$$

Score 2: The student has a complete and correct response.

Question 32

32 Multiply $x + yi$ by its conjugate, and express the product in simplest form.

$$\begin{aligned} & (x+yi)(x-yi) \\ & x^2 - xyi + xyi - y^2i^2 \\ & x^2 - y^2i^2 \end{aligned}$$

Score 1: The student made one conceptual error by not substituting for i^2 .

Question 32

32 Multiply $x + yi$ by its conjugate, and express the product in simplest form.

$$\begin{aligned} & \overbrace{(x + yi)(-x - yi)} \\ & -x^2 + xyi - xyi - yi^2 \\ & -x^2 - 1 - yi^2 \\ & -x^2 - 1 - (-1) \\ & \text{---} \end{aligned}$$

$x + yi$
 $x - yi$

Conjugates.

$-x^2 + 2$

Score 0: The student made one conceptual error in writing the conjugate and multiple computational errors.

Question 33

33 Solve algebraically for x :

$$\log_{5x-1} 4 = \frac{1}{3}$$

$$(5x-1)^{\frac{1}{3}} = 4$$

$$5x-1 = 4^3$$

$$5x-1 = 64$$

$$5x = 65$$

$$x = 13$$

Score 2: The student has a complete and correct response.

Question 33

33 Solve algebraically for x :

$$\log_{5x-1} 4 = \frac{1}{3}$$

$$\frac{\log 4}{\log 5x-1} = \frac{1}{3}$$

$$3 \log 4 = \log 5x-1$$

$$\log 64 = \log 5x-1$$

$$64 = 5x-1$$

$$65 = 5x$$

$$\boxed{13 = x}$$

Score 2: The student has a complete and correct response.

Question 33

33 Solve algebraically for x:

$$\log_{5x-1} 4 = \frac{1}{3}$$

$$(5x-1)^{\frac{1}{3}} = 4$$

$$5x^{\frac{1}{3}} - 1^{\frac{1}{3}} = 4$$

↓

$$+ .333333 = 4$$

+ .37

$$5x^{\frac{1}{3}} = 4 + 1^{\frac{1}{3}} \quad \left(\frac{3}{1}\right)$$

$$5x = 4^{\frac{(3)}{1}} + 1^{\frac{(1/3 \cdot 3)}{1}}$$

$$5x = 64 + 1$$

$$\frac{5x}{5} = \frac{65}{5}$$

$$\boxed{x=13}$$

Score 1: The equation $(5x-1)^{\frac{1}{3}} = 4$ is written, but no further correct work is shown.

Question 33

33 Solve algebraically for x :

$$\log_{5x-1} 4 = \frac{1}{3}$$

$$5x - 1^{\frac{1}{3}} = 4$$

$$5x - 1 = 4$$

$$\begin{array}{r} 4 \quad +1 \\ \hline 5x = 5 \end{array}$$

$$x = 1$$

Score 1: The student made one conceptual error.

Question 33

33 Solve algebraically for x :

$$\log_{5x-1} 4 = \frac{1}{3}$$

$$(5x-1)^3 = 4$$

$$5x-1 = 4^{\frac{1}{3}}$$

$$5x-1 = 1.58$$

$$x = .516$$

Score 0: The student made one conceptual error and one rounding error.

Question 34

34 Solve $\sec x - \sqrt{2} = 0$ algebraically for all values of x in $0^\circ \leq x < 360^\circ$.

$$\sec x - \sqrt{2} = 0$$

$$\sec x = \sqrt{2}$$

~~Q~~
Q I, IV

R 45°

S 45°

$$360 - 45 = 315$$

$\{45^\circ, 315^\circ\}$

Score 2: The student has a complete and correct response.

Question 34

34 Solve $\sec x - \sqrt{2} = 0$ algebraically for all values of x in $0^\circ \leq x < 360^\circ$.

$$\sec(x) = \sqrt{2}$$

$$x = 45^\circ$$

$$45^\circ, 135^\circ, 225^\circ, 315^\circ$$

$$45 + 90 = 135$$

$$45 + 180 = 225$$

$$45 + 270 = 315$$

Score 1: The student found one solution, but no further correct work is shown.

Question 34

34 Solve $\sec x - \sqrt{2} = 0$ algebraically for all values of x in $0^\circ \leq x < 360^\circ$.

$$\frac{1}{\cos x} - \sqrt{2} = 0$$
$$\frac{1}{\cos x} = \sqrt{2}$$

Score 0: The student did not find any solutions.

Question 34

34 Solve $\sec x - \sqrt{2} = 0$ algebraically for all values of x in $0^\circ \leq x < 360^\circ$.

$$\frac{1}{\sin x} = \frac{\sqrt{2}}{1}$$
$$\sin x = \frac{\sqrt{2}}{2}$$

~~45~~

Score 0: The student made one conceptual error and then found only one solution.

Question 35

35 The function $f(x)$ is graphed on the set of axes below.

On the same set of axes, graph $f(x + 1) + 2$.

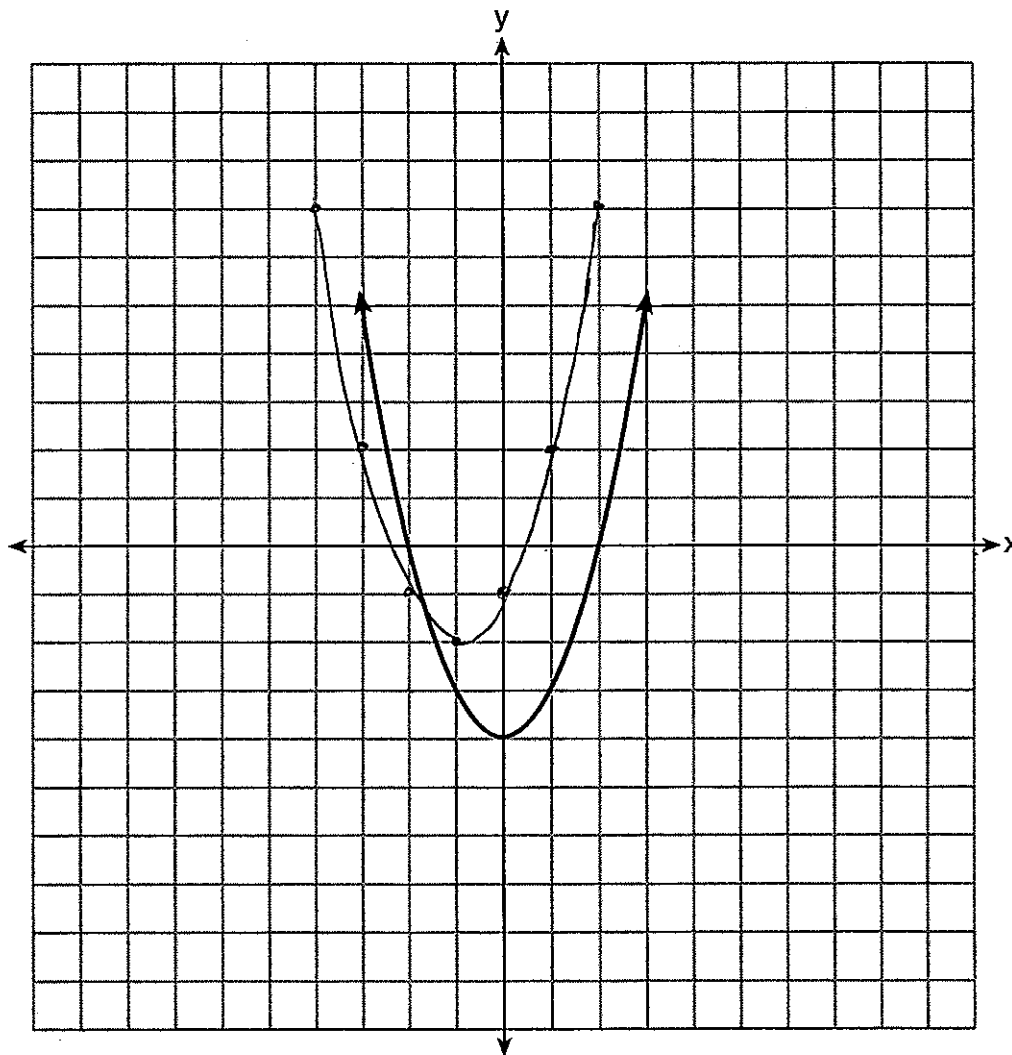

Score 2: The student has a complete and correct response.

Question 35

35 The function $f(x)$ is graphed on the set of axes below.

On the same set of axes, graph $f(x + 1) + 2$.

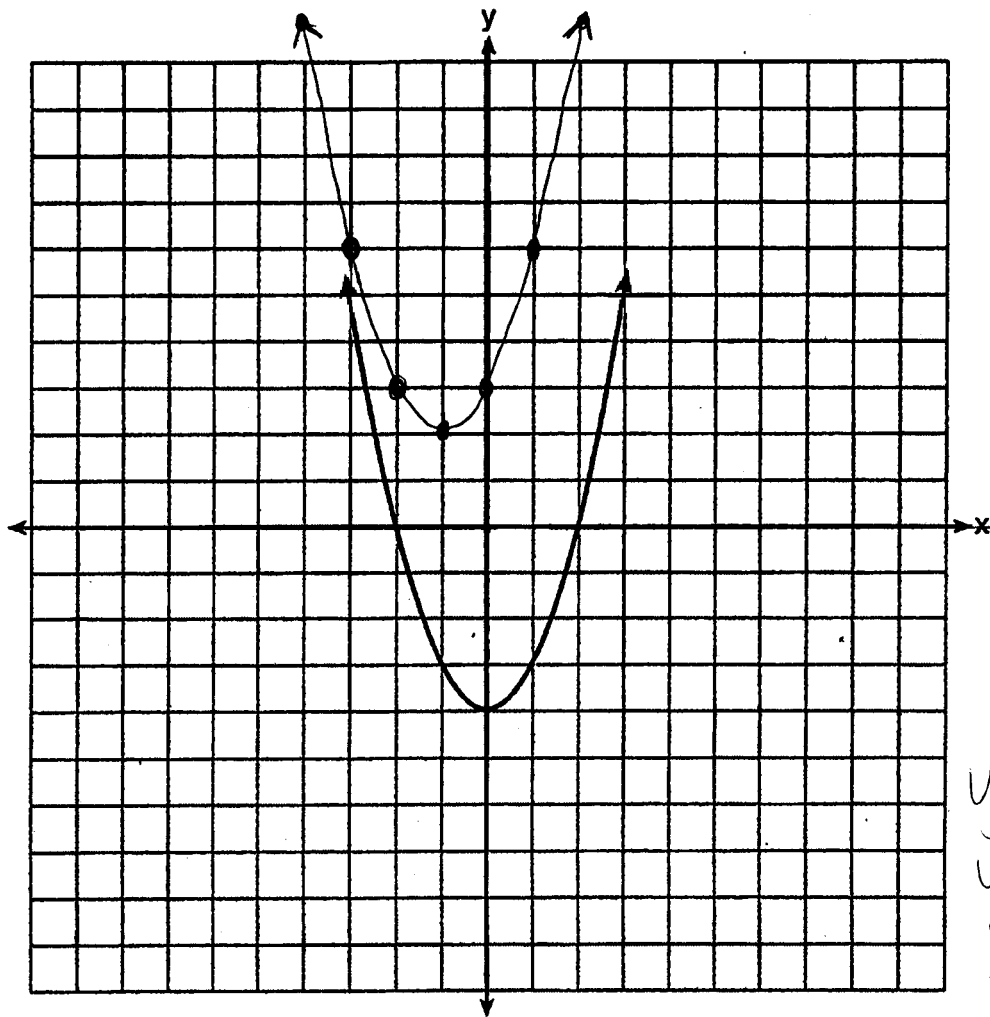

$$y = (x+1)^2 + 2$$
$$y = x^2 + 2x + 1 + 2$$
$$y = x^2 + 2x + 3$$

Score 1: The student made one conceptual error by applying the transformation to $y = x^2$.

Question 35

35 The function $f(x)$ is graphed on the set of axes below.

On the same set of axes, graph $f(x + 1) + 2$.

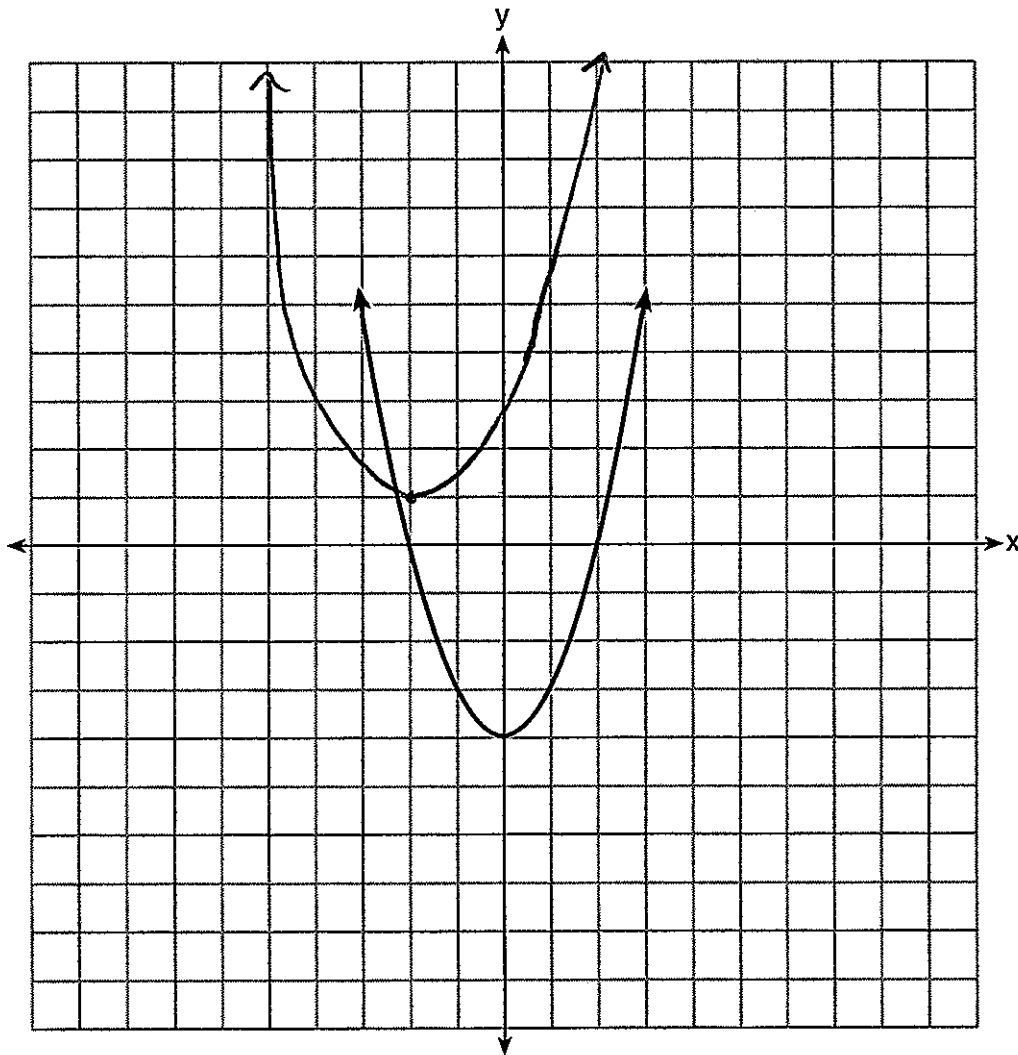

Score 0: The student made multiple graphing errors.

Question 36

36 Express in simplest terms:

$$\frac{x^2 \left(1 + \frac{3}{x}\right) x^2}{x^2 \left(1 - \frac{5}{x} + \frac{24}{x^2}\right) x^2}$$

$$\frac{x^2 + 3x}{x^2 - 5x - 24}$$

$$\frac{x(x+3)}{(x+3)(x-8)}$$

$$\boxed{\frac{x}{x-8}}$$

Score 4: The student has a complete and correct response.

Question 36

36 Express in simplest terms:

$$\frac{\left(\frac{1}{x^2}\right) \left(4 + \frac{3}{x}\right)}{\left(\frac{1}{x^2}\right) \left(1 - \frac{5}{x}\right) \left(\frac{24}{x^2}\right)}$$

$$\frac{\frac{x^3}{x^3} + \frac{3x^2}{x^3}}{\frac{x^3}{x^3} - \frac{5x^2}{x^3} - \frac{24x}{x^3}}$$

$$\frac{x^2(x+3)}{x^3 - 5x^2 - 24x}$$

$$x - 8 \cancel{(x+3)}$$

$$\frac{x^2}{x-8}$$

Score 3: The student made one factoring error.

Question 36

36 Express in simplest terms:

$$\frac{\left(1 + \frac{3}{x}\right) x}{\left(1 - \frac{5}{x} - \frac{24}{x^2}\right) x^2} \rightarrow \frac{\cancel{x+3}}{\cancel{x^2-5x-24} (x-8)\cancel{(x+3)}}$$

$$\left(\frac{5}{x} + \frac{24}{x^2} + 1 + \frac{3}{x}\right) (x^2)$$

$$5x + 24 + x^2 + 3x$$

$$x^2 + 8x + 24$$

1
x-8

Score 2: The student made one conceptual error.

Question 36

36 Express in simplest terms:

$$\frac{1 + \frac{3}{x}}{1 - \frac{5}{x} - \frac{24}{x^2}}$$

$$\frac{(x)1}{(x)1} + \frac{3}{x} \quad \frac{x+3}{x}$$

$$\frac{(x)1}{(x)1} - \frac{5}{x} \quad \frac{(x)x-5}{x(x)} - \frac{24}{x^2}$$

$$\frac{x^2 - 5x - 24}{x^2} \cdot \frac{x}{x+3}$$

$$\frac{(x-8)(\cancel{x+3})}{x \cancel{x}} \cdot \frac{x}{\cancel{x+3}}$$

$$\frac{(x-8)x}{x^2} \quad \boxed{\frac{x^2 - 8x}{x^2}}$$

Score 1: The student made one conceptual error and one simplification error.

Question 36

36 Express in simplest terms:

$$\frac{(x) \frac{1}{x} + \frac{3}{x}}{(x^2) 1 - \frac{5}{x(x)} - \frac{24}{x^2}} = \frac{x+3}{x} \cdot \frac{x^2 - 5x - 24}{x^2}$$
$$\frac{\cancel{x+3}}{\cancel{x}} \cdot \frac{(x-8)(\cancel{x+3})}{\cancel{x^2} x}$$
$$\frac{x-8}{x}$$

Score 0: The student made two conceptual errors.

Question 37

37 Solve $x^3 + 5x^2 = 4x + 20$ algebraically.

$$\begin{array}{l} x^3 + 5x^2 \overline{) -4x - 20} \\ \underline{x^2(x+5)} \\ -4(x+5) \end{array}$$

$$\begin{array}{l} (x^2 - 4) \mid (x + 5) = 0 \\ x^2 - 4 = 0 \\ x = 2 \\ x = -2 \end{array} \quad \begin{array}{l} (x + 5) = 0 \\ x + 5 = 0 \\ x = -5 \end{array}$$

Score 4: The student has a complete and correct response.

Question 37

37 Solve $x^3 + 5x^2 = 4x + 20$ algebraically.

$$\underline{x^3 + 5x^2} - \underline{4x - 20} = 0$$

$$x^2(x+5) - 4(x+5) = 0$$

$$(x^2 - 4)(x+5) = 0$$

$$(x-4)(x+4)(x+5) = 0$$

$x - 4 = 0$	$x + 4 = 0$	$x + 5 = 0$
$+4 +4$	$-4 -4$	$-5 -5$
$x = 4$	$x = -4$	$x = -5$

$$\{-4, 4, -5\}$$

Score 3: The student made one factoring error.

Question 37

37 Solve $x^3 + 5x^2 = 4x + 20$ algebraically.

$$x^3 + 5x^2 - 4x - 20 = 0$$

$$x^2(x+5) - 4(x+5) = 0$$

$$(x^2 - 4)(x+5) = 0$$

$$(x+2)(x-2)(x+5) = 0$$

Score 2: The student wrote $(x^2 - 4)(x + 5) = 0$, but did not complete the solution.

Question 37

37 Solve $x^3 + 5x^2 = 4x + 20$ algebraically.

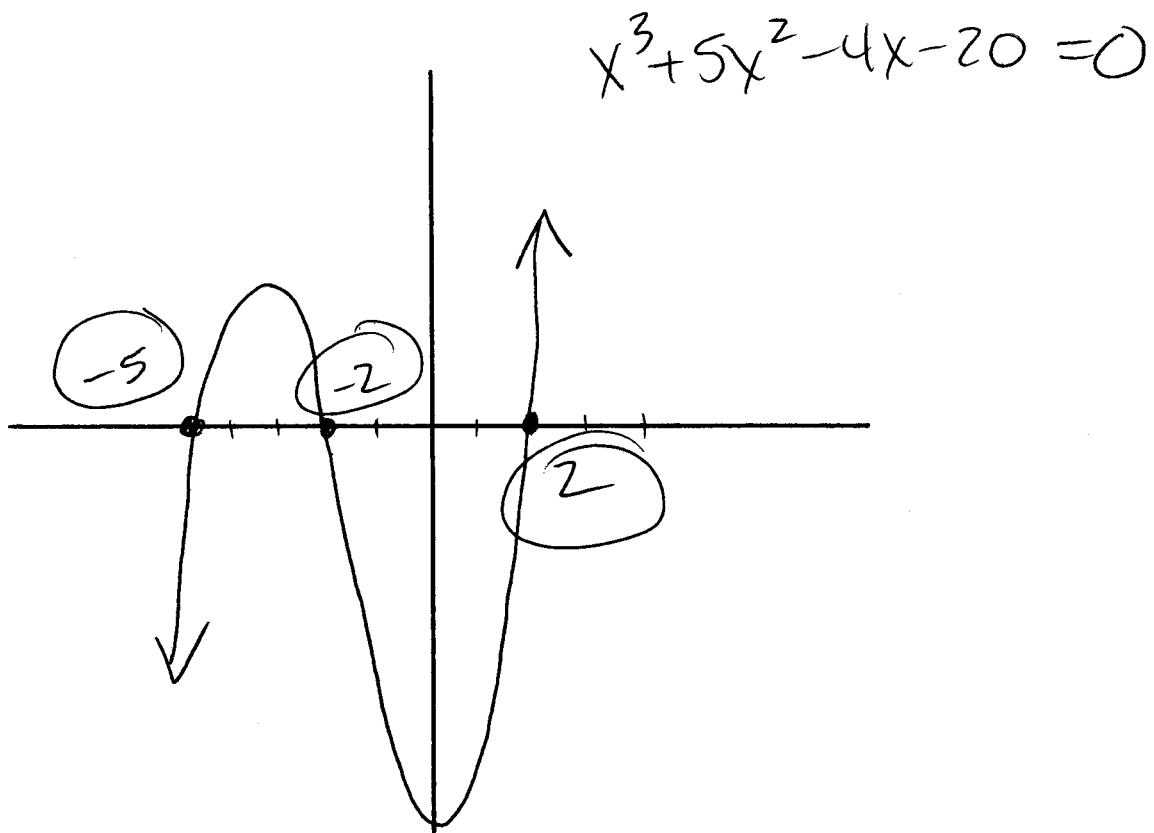

Score 2: The student used a method other than algebraic to solve the equation.

Question 37

37 Solve $x^3 + 5x^2 = 4x + 20$ algebraically.

$$x^3 + 5x^2 = 4x + 20$$

$$x^3 + 5x^2 - 4x - 20 = 0$$

$$x(x^2 + 5x - 4 - 20) = 0$$

$$\cancel{x=0} \quad (x^2 + 5x - 24) = 0$$

$$(x-3)(x+8) = 0$$

$$x=3 \quad x=-8$$

Score 1: The student made one conceptual error by misidentifying the GCF as x and then rejected $x = 0$ as part of the solution.

Question 37

37 Solve $x^3 + 5x^2 = 4x + 20$ algebraically.

$$x^2(x+5) = 4(y+5)$$

$$\sqrt{x^2} = \sqrt{4}$$

$$x = 2$$

Score 0: The student made two conceptual errors.

Question 38

38 Whenever Sara rents a movie, the probability that it is a horror movie is 0.57. Of the next five movies she rents, determine the probability, to the *nearest hundredth*, that *no more than two* of these rentals are horror movies.

$$p: .57$$

$$q: .43$$

$$n: 5$$

$$r: 2, 1, 0$$

$${}^5C_2 (.57)^2 (.43)^3 = .258318243$$

$${}^5C_1 (.57)^1 (.43)^4 = .0974358285$$

$${}^5C_0 (.57)^0 (.43)^5 = .0147008443$$

$$.3704549158$$

$.37$

Score 4: The student has a complete and correct response.

Question 38

38 Whenever Sara rents a movie, the probability that it is a horror movie is 0.57. Of the next five movies she rents, determine the probability, to the *nearest hundredth*, that *no more than* two of these rentals are horror movies.

$$\text{binomial pdf}(5, .57, 0) + \text{binomial pdf}(5, .57, 1) + \text{binomial pdf}(5, .57, 2) = .3704549158$$

.37

Score 4: The student has a complete and correct response.

Question 38

38 Whenever Sara rents a movie, the probability that it is a horror movie is 0.57. Of the next five movies she rents, determine the probability, to the *nearest hundredth*, that *no more than two* of these rentals are horror movies.

$${}^5C_0 (.57)^0 (.43)^5 = 0.0147008443$$

$${}^5C_1 (.57)^1 (.43)^4 = 0.0974358285$$

$${}^5C_2 (.57)^2 (.43)^3 = 0.258318243$$

Score 3: The student did not find the sum.

Question 38

38 Whenever Sara rents a movie, the probability that it is a horror movie is 0.57. Of the next five movies she rents, determine the probability, to the *nearest hundredth*, that *no more than two* of these rentals are horror movies.

$$\begin{aligned} p &: .57 \\ q &: .43 \\ n &: 5 \\ r &: 1, 2 \end{aligned} \quad \begin{aligned} & {}_5C_1 \times .57^1 \cdot .43^4 \\ & + \\ & {}_5C_2 \times .57^2 \times .43^3 \end{aligned}$$

~~.1116768~~

$$.09743583 + .258318 = 0.36$$

$$= 36\%$$

Score 2: The student made one conceptual error by not finding the probability of ${}_5C_0$.

Question 38

38 Whenever Sara rents a movie, the probability that it is a horror movie is 0.57. Of the next five movies she rents, determine the probability, to the nearest hundredth, that no more than two of these rentals are horror movies.

$$\begin{aligned}
 & {}_5C_0 \left(\frac{57}{100}\right)^0 \left(\frac{43}{100}\right)^5 \\
 & {}_5C_1 \left(\frac{57}{100}\right)^1 \left(\frac{43}{100}\right)^4 \\
 & {}_5C_2 \left(\frac{57}{100}\right)^2 \left(\frac{43}{100}\right)^3
 \end{aligned}$$

$$\begin{aligned}
 & 5(1) \left(\frac{147908443}{1000000000}\right) \quad .0229345007 \\
 & 5 \left(\frac{2441}{100}\right) \left(\frac{2418801}{100000000}\right) \quad .03418801 \\
 & + 10 \left(\frac{3249}{1000001}\right) \left(\frac{79507}{10000000}\right) \quad .079507 \\
 & \quad .3249 \quad .079507 \\
 & \quad \underline{.258318} \\
 & \quad .258318
 \end{aligned}$$

$$\begin{aligned}
 & .1146725035 \\
 & + .0914365285 \\
 & \quad .258318243 \\
 & \quad \underline{\hspace{1.5cm}} \\
 & \quad .47 \text{ chance of horror movies}
 \end{aligned}$$

Score 2: The student made two computational errors when evaluating ${}_5C_0 \left(\frac{57}{100}\right)^0 \left(\frac{43}{100}\right)^5$.

Question 38

38 Whenever Sara rents a movie, the probability that it is a horror movie is 0.57. Of the next five movies she rents, determine the probability, to the *nearest hundredth*, that *no more than* two of these rentals are horror movies.

57%.

$$5C_2 (.57)^2 (.43)^3 = \frac{.26}{1}$$

Score 1: The student found the probability of exactly two movies.

Question 38

38 Whenever Sara rents a movie, the probability that it is a horror movie is 0.57. Of the next five movies she rents, determine the probability, to the *nearest hundredth*, that *no more than* two of these rentals are horror movies.

$$5C_2 \left(\frac{57}{100}\right)^2 \left(\frac{43}{100}\right)^3 =$$

.32

Score 0: The student did not correctly evaluate the probability of exactly two movies.

Question 39

39 Two forces of 40 pounds and 28 pounds act on an object. The angle between the two forces is 65° . Find the magnitude of the resultant force, to the *nearest pound*.
Using this answer, find the measure of the angle formed between the resultant and the *smaller* force, to the *nearest degree*.

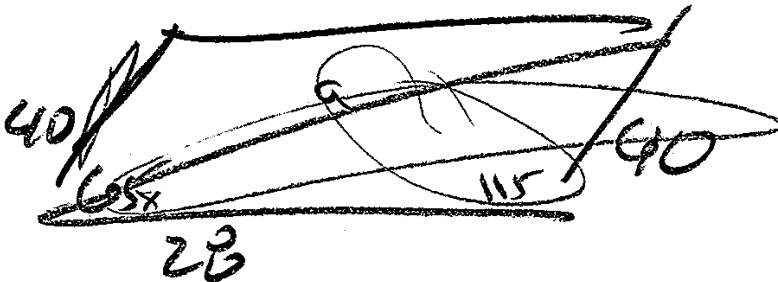

$$a^2 = 28^2 + 40^2 - 2(28)(40)\cos 115$$

$$a^2 = 3330.6649$$

$$a = 57.7119$$

$$\boxed{58 \text{ lb}}$$

$$\frac{40}{\sin x} = \frac{58}{\sin 115}$$

$$40 \sin 115 = 58 \sin x$$

$$.6250 = \sin x$$

$$38.6851 = x$$

$$\boxed{39^\circ}$$

Score 6: The student has a complete and correct response.

Question 39

39 Two forces of 40 pounds and 28 pounds act on an object. The angle between the two forces is 65° . Find the magnitude of the resultant force, to the nearest pound.

Using this answer, find the measure of the angle formed between the resultant and the smaller force, to the nearest degree.

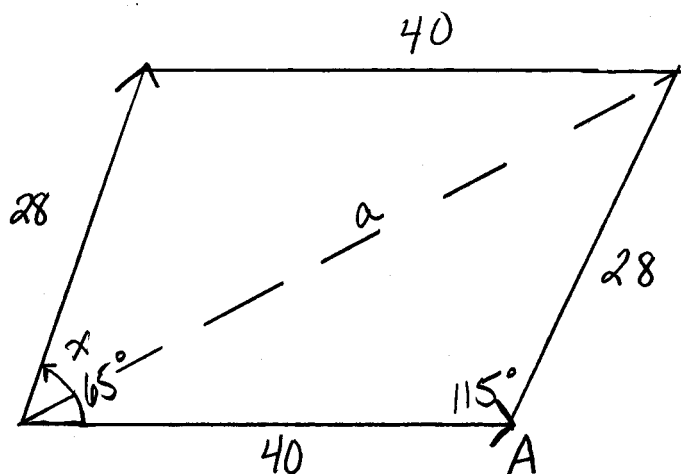

$$a^2 = b^2 + c^2 - 2bc \cos A$$

$$a^2 = 28^2 + 40^2 - 2(28)(40) \cos 115$$

$$a^2 = 3330.664906$$

$$a = 57.7119$$

$$\boxed{a = 58}$$

$$40^2 = 28^2 + 58^2 - 2(28)(58) \cos x$$

$$1600 = 784 + 3364 - 3248 \cos x$$

$$1000 = 4148 - 3248 \cos x$$

$$-2548 = -3248 \cos x$$

$$0.784482759 = \cos x$$

$$x = 38.327$$

$$x = 38^\circ$$

Score 6: The student has a complete and correct response.

Question 39

- 39 Two forces of 40 pounds and 28 pounds act on an object. The angle between the two forces is 65° . Find the magnitude of the resultant force, to the nearest pound.
Using this answer, find the measure of the angle formed between the resultant and the smaller force, to the nearest degree.

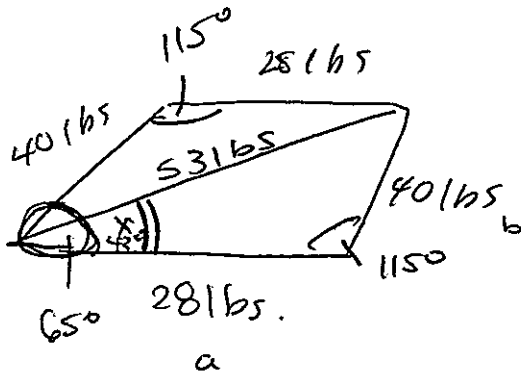

$$180 - 65^\circ = 115^\circ$$

$$c^2 = a^2 + b^2 - 2ab \cos C$$

$$c^2 = 28^2 + 40^2 - 28(40) \cos 115^\circ$$

$$c^2 \approx 5316.5$$

↑
magnitude of resultant

$$\frac{\sin 115^\circ}{53} = \frac{\sin x}{40}$$

$$\sin 115^\circ (40) = \sin x (53)$$

$$x \approx 43^\circ$$

Score 5: The student made one computational error by dropping the 2 in the equation $c^2 = 28^2 + 40^2 - 28(40) \cos 115^\circ$.

Question 39

39 Two forces of 40 pounds and 28 pounds act on an object. The angle between the two forces is 65° . Find the magnitude of the resultant force, to the *nearest pound*.

Using this answer, find the measure of the angle formed between the resultant and the *smaller* force, to the *nearest degree*.

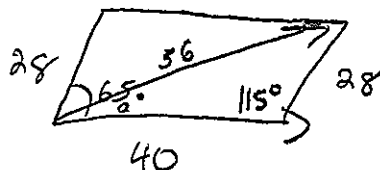

$$x^2 = 40^2 + 28^2 - 2(40)(28) \cos 115^\circ$$
$$\approx 55.8 \approx \boxed{56 \text{ pounds}}$$

$$28^2 = 56^2 + 40^2 - 2(56)(40) \cos A$$

$$784 = 4736 - 4480 \cos A$$

$$-3952 = -4480 \cos A$$

$$\cos A \approx 0.88214$$

$$\boxed{A \approx 28^\circ}$$

Score 5: The student found the magnitude of the resultant incorrectly by using radians instead of degrees, but then correctly found the angle, in degrees, based on their magnitude.

Question 39

39 Two forces of 40 pounds and 28 pounds act on an object. The angle between the two forces is 65° . Find the magnitude of the resultant force, to the *nearest pound*.

Using this answer, find the measure of the angle formed between the resultant and the *smaller* force, to the *nearest degree*.

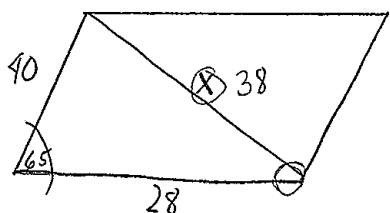

LAW OF COSINES

$$a^2 = b^2 + c^2 - 2bc \cos A$$

$$a^2 = (40)^2 + (28)^2 - 2(40)(28) \cos(65)$$

$$a^2 = 2384 - 964.6649063$$

$$\sqrt{a^2} = \sqrt{1437.335094}$$

$$a = 37.91220244$$

$$\text{magnitude of resultant} = \underline{38 \text{ lb}}$$

LAW OF SINES

$$\frac{a}{\sin A} = \frac{b}{\sin B}$$

$$\frac{38}{\sin 65} = \frac{40}{\sin B}$$

$$\frac{38 \sin B}{38} = \frac{40 \sin 65}{38}$$

$$\sin B = \frac{40 \sin 65}{38}$$

$$\sin B = .9540081969$$

$$B = 72.55557886$$

$$\angle = \underline{73^\circ}$$

Score 4: The student made one conceptual error.

Question 39

39 Two forces of 40 pounds and 28 pounds act on an object. The angle between the two forces is 65° . Find the magnitude of the resultant force, to the *nearest pound*.

Using this answer, find the measure of the angle formed between the resultant and the *smaller* force, to the *nearest degree*.

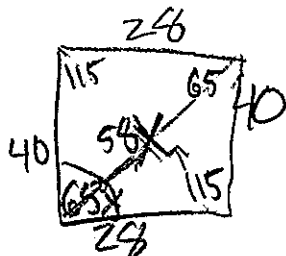

$$X^2 = 28^2 + 40^2 - 2(28)(40)\cos 115$$

$$X^2 = 3330, 66496$$

$$X = 58$$

$$\frac{X}{\sin 40} = \frac{58}{\sin 115}$$

$$\frac{58 \sin 40}{\sin 115} = \frac{X \sin 115}{\cancel{\sin 115}}$$

$$X = 41^\circ$$

Score 4: The student made one conceptual error in using the Law of Sines.

Question 39

39 Two forces of 40 pounds and 28 pounds act on an object. The angle between the two forces is 65° . Find the magnitude of the resultant force, to the nearest pound.

Using this answer, find the measure of the angle formed between the resultant and the smaller force, to the nearest degree.

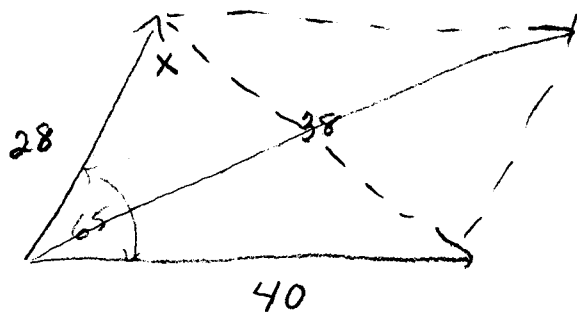

$$c^2 = a^2 + b^2 - 2ab \cos C$$

$$c^2 = 28^2 + 40^2 - 2(28)(40) \cos 65$$

$$c^2 = 784 + 1600 - 2240 \cos 65$$

$$c^2 = 2384 - 2240 \cos 65$$

$$c^2 = 1437$$

$$c = 38$$

$$\frac{\sin 65}{38} = \frac{\sin x}{40}$$

$$36 = 38 \sin x$$

$$x = 72$$

Score 3: The student made one conceptual error and one rounding error.

Question 39

39 Two forces of 40 pounds and 28 pounds act on an object. The angle between the two forces is 65° . Find the magnitude of the resultant force, to the nearest pound.
Using this answer, find the measure of the angle formed between the resultant and the smaller force, to the nearest degree.

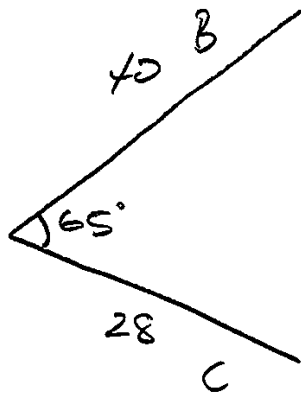

resultant force = 38 pounds

$$a^2 = 40^2 + 28^2 - 2(40)(28)\cos 65$$

$$a^2 = 2384 - 946.66 + 9063$$

$$a^2 = 1437.335094$$

$$a = 37.91$$

$$a = 38$$

$$\frac{38}{65} = \frac{40}{x}$$

$$\underline{38x = 2600}$$

$$x = 68.42$$

$\angle = 68^\circ$

Score 2: The student made two conceptual errors.

Question 39

39 Two forces of 40 pounds and 28 pounds act on an object. The angle between the two forces is 65° . Find the magnitude of the resultant force, to the *nearest pound*.

Using this answer, find the measure of the angle formed between the resultant and the *smaller* force, to the *nearest degree*.

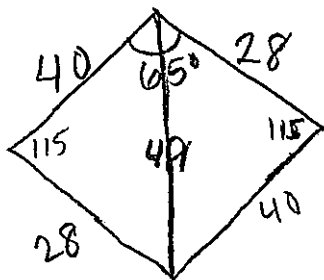

$$28^2 + 40^2 = c^2$$

$$\sqrt{2384} = c$$

$$49 = c$$

$$\frac{49}{\sin 115} = \frac{40}{\sin x}$$

$$49 \sin x = 36$$

$$\sin x = .7425$$

$$x = 47.9$$

$$x = 48^\circ$$

Score 2: The student made one conceptual error in finding the resultant, followed by one rounding error and one computational error in using the Law of Sines.

Question 39

- 39 Two forces of 40 pounds and 28 pounds act on an object. The angle between the two forces is 65° . Find the magnitude of the resultant force, to the *nearest pound*.
Using this answer, find the measure of the angle formed between the resultant and the *smaller* force, to the *nearest degree*.

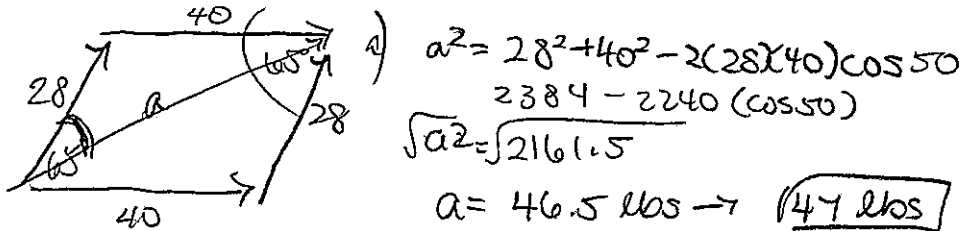

Score 1: The student correctly drew and labeled the diagram, but no further correct work is shown.

Question 39

- 39 Two forces of 40 pounds and 28 pounds act on an object. The angle between the two forces is 65° . Find the magnitude of the resultant force, to the nearest pound.
Using this answer, find the measure of the angle formed between the resultant and the smaller force, to the nearest degree.

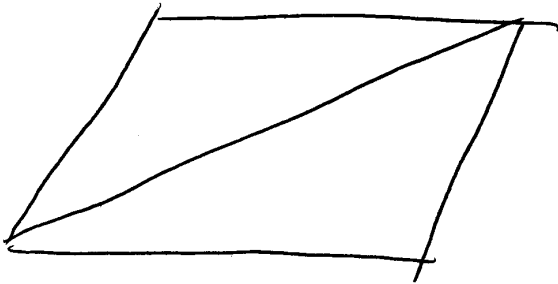

$$\begin{aligned}
 a^2 + b^2 &= c^2 \\
 28^2 + 40^2 &= c^2 \\
 784 + 1600 &= c^2 \\
 \sqrt{2384} &= c^2 \\
 48.8 &= c \\
 \textcircled{48} &= c
 \end{aligned}$$

$$\begin{aligned}
 c^2 &= a^2 + b^2 - 2(ab)\cos C \\
 48^2 &= 40^2 + 28^2 - 2(40)(28)\cos C \\
 2304 &= 1600 + 784 - 2(1120)\cos C \\
 2304 &= 1600 + 784 - 2240\cos C \\
 2304 &= 2384 - 2240\cos C \\
 \frac{2304}{144} &= \frac{144\cos C}{144} \\
 16 &= \cos
 \end{aligned}$$

Score 0: The student did not label the diagram, made two conceptual errors and one rounding error, and did not state the angle.

Regents Examination in Algebra 2/Trigonometry – June 2014

Chart for Converting Total Test Raw Scores to Final Examination Scores (Scale Scores)

Raw Score	Scale Score	Raw Score	Scale Score	Raw Score	Scale Score	Raw Score	Scale Score
88	100	65	83	43	62	21	35
87	99	64	82	42	61	20	34
86	99	63	81	41	60	19	32
85	98	62	80	40	59	18	31
84	98	61	79	39	57	17	29
83	97	60	79	38	56	16	28
82	96	59	78	37	55	15	26
81	96	58	77	36	54	14	25
80	95	57	76	35	53	13	23
79	94	56	75	34	52	12	21
78	94	55	74	33	51	11	20
77	93	54	73	32	49	10	18
76	92	53	72	31	48	9	17
75	91	52	71	30	47	8	15
74	91	51	70	29	46	7	13
73	90	50	69	28	45	6	12
72	89	49	68	27	43	5	10
71	88	48	67	26	42	4	8
70	87	47	66	25	41	3	6
69	86	46	65	24	39	2	4
68	86	45	64	23	38	1	2
67	85	44	63	22	37	0	0
66	84						

To determine the student's final examination score, find the student's total test raw score in the column labeled "Raw Score" and then locate the scale score that corresponds to that raw score. The scale score is the student's final examination score. Enter this score in the space labeled "Scale Score" on the student's answer sheet.

Schools are not permitted to rescore any of the open-ended questions on this exam after each question has been rated once, regardless of the final exam score. Schools are required to ensure that the raw scores have been added correctly and that the resulting scale score has been determined accurately.

Because scale scores corresponding to raw scores in the conversion chart change from one administration to another, it is crucial that for each administration the conversion chart provided for that administration be used to determine the student's final score. The chart above is usable only for this administration of the Regents Examination in Algebra 2/Trigonometry.