

JMAP
REGENTS BY PERFORMANCE
INDICATOR: TOPIC

NY Integrated Algebra Regents Exam Questions
from Fall 2007 to June 2015 Sorted by PI: Topic

www.jmap.org

Integrated Algebra Regents Exam Questions by Performance Indicator: Topic

NUMBERS, OPERATIONS

AND PROPERTIES

A.N.6: EVALUATING EXPRESSIONS

1 What is the value of the expression $|-5x + 12|$ when $x = 5$?

- 1 -37
- 2 -13
- 3 13
- 4 37

2 The value of the expression $-|a - b|$ when $a = 7$ and $b = -3$ is

- 1 -10
- 2 10
- 3 -4
- 4 4

3 What is the value of the expression $(a^3 + b^0)^2$ when $a = -2$ and $b = 4$?

- 1 64
- 2 49
- 3 -49
- 4 -64

4 What is the value of the expression $-3x^2y + 4x$ when $x = -4$ and $y = 2$?

- 1 -112
- 2 -80
- 3 80
- 4 272

5 What is the value of $\left| \frac{4(-6) + 18}{4!} \right|$?

- 1 $\frac{1}{4}$
- 2 $-\frac{1}{4}$
- 3 12
- 4 -12

6 If $x = -3$, what is the value of $|x - 4| - x^2$?

- 1 -8
- 2 -2
- 3 7
- 4 16

7 The value of the expression $6! + \frac{5!(3!)}{4!} - 10$ is

- 1 50
- 2 102
- 3 740
- 4 750

8 When $x = 4$, the value of $2x^0 + x!$ is

- 1 24
- 2 25
- 3 26
- 4 28

9 What is the value of the expression $3a^2 - 4|a| + 6$ when $a = -3$?

- 1 -24
- 2 -9
- 3 21
- 4 45

10 The value of the expression $|-20| - |6|$ is

- 1 26
- 2 14
- 3 -14
- 4 -26

A.N.1: IDENTIFYING PROPERTIES

11 Which property is illustrated by the equation $ax + ay = a(x + y)$?

- 1 associative
- 2 commutative
- 3 distributive
- 4 identity

Integrated Algebra Regents Exam Questions by Performance Indicator: Topic

www.jmap.org

- 12 The statement $2 + 0 = 2$ is an example of the use of which property of real numbers?
- 1 associative
 - 2 additive identity
 - 3 additive inverse
 - 4 distributive

- 13 A method for solving $5(x - 2) - 2(x - 5) = 9$ is shown below. Identify the property used to obtain each of the two indicated steps.

$$5(x - 2) - 2(x - 5) = 9$$

(1) $5x - 10 - 2x + 10 = 9$	(1) _____
(2) $5x - 2x - 10 + 10 = 9$	(2) _____

$$3x + 0 = 9$$

$$3x = 9$$

$$x = 3$$

- 14 The equation $3(4x) = (4x)3$ illustrates which property?
- 1 commutative
 - 2 associative
 - 3 distributive
 - 4 multiplicative inverse

- 15 When solving for the value of x in the equation $4(x - 1) + 3 = 18$, Aaron wrote the following lines on the board.

[line 1]	$4(x - 1) + 3 = 18$
[line 2]	$4(x - 1) = 15$
[line 3]	$4x - 1 = 15$
[line 4]	$4x = 16$
[line 5]	$x = 4$

Which property was used *incorrectly* when going from line 2 to line 3?

- 1 distributive
- 2 commutative
- 3 associative
- 4 multiplicative inverse

- 16 A teacher asked the class to solve the equation $3(x + 2) = 21$. Robert wrote $3x + 6 = 21$ as his first step. Which property did he use?
- 1 associative property
 - 2 commutative property
 - 3 distributive property
 - 4 zero property of addition

- 17 The equation $(x - 6)(8 + x) = (x - 6) \cdot (8) + (x - 6) \cdot (x)$ illustrates the use of which property?
- 1 distributive property
 - 2 associative property of addition
 - 3 associative property of multiplication
 - 4 commutative property of multiplication

A.N.1: PROPERTIES OF REALS

- 18 What is the additive inverse of the expression $a - b$?
- 1 $a + b$
 - 2 $a - b$
 - 3 $-a + b$
 - 4 $-a - b$

- 19 Perform the indicated operation: $-6(a - 7)$
State the name of the property used.

- 20 Which equation illustrates the associative property?
- 1 $x + y + z = x + y + z$
 - 2 $x(y + z) = xy + xz$
 - 3 $x + y + z = z + y + x$
 - 4 $(x + y) + z = x + (y + z)$

- 21 Which equation is an example of the use of the associative property of addition?
- 1 $x + 7 = 7 + x$
 - 2 $3(x + y) = 3x + 3y$
 - 3 $(x + y) + 3 = x + (y + 3)$
 - 4 $3 + (x + y) = (x + y) + 3$

Integrated Algebra Regents Exam Questions by Performance Indicator: Topic

www.jmap.org

- 22 Which statement illustrates the additive identity property?
 1 $6 + 0 = 6$
 2 $-6 + 6 = 0$
 3 $4(6 + 3) = 4(6) + 4(3)$
 4 $(4 + 6) + 3 = 4 + (6 + 3)$
- 23 Which equation illustrates the multiplicative inverse property?
 1 $a \cdot 1 = a$
 2 $a \cdot 0 = 0$
 3 $a\left(\frac{1}{a}\right) = 1$
 4 $(-a)(-a) = a^2$
- 28 Which interval notation represents the set of all numbers greater than or equal to 5 and less than 12?
 1 $[5, 12)$
 2 $(5, 12]$
 3 $(5, 12)$
 4 $[5, 12]$
- 29 Which set-builder notation describes $\{-3, -2, -1, 0, 1, 2\}$?
 1 $\{x | -3 \leq x < 2, \text{ where } x \text{ is an integer}\}$
 2 $\{x | -3 < x \leq 2, \text{ where } x \text{ is an integer}\}$
 3 $\{x | -3 < x < 2, \text{ where } x \text{ is an integer}\}$
 4 $\{x | -3 \leq x \leq 2, \text{ where } x \text{ is an integer}\}$

A.N.1: PROPERTIES OF INTEGERS

- 24 The set of integers is *not* closed for
 1 division
 2 multiplication
 3 addition
 4 subtraction
- 30 Which interval notation represents the set of all real numbers greater than 2 and less than or equal to 20?
 1 $(2, 20)$
 2 $(2, 20]$
 3 $[2, 20)$
 4 $[2, 20]$

A.A.29: SET THEORY

- 25 Which interval notation represents the set of all numbers from 2 through 7, inclusive?
 1 $(2, 7)$
 2 $(2, 7]$
 3 $[2, 7)$
 4 $[2, 7]$
- 26 The set $\{1, 2, 3, 4\}$ is equivalent to
 1 $\{x | 1 < x < 4, \text{ where } x \text{ is a whole number}\}$
 2 $\{x | 0 < x < 4, \text{ where } x \text{ is a whole number}\}$
 3 $\{x | 0 < x \leq 4, \text{ where } x \text{ is a whole number}\}$
 4 $\{x | 1 < x \leq 4, \text{ where } x \text{ is a whole number}\}$
- 27 The set $\{11, 12\}$ is equivalent to
 1 $\{x | 11 < x < 12, \text{ where } x \text{ is an integer}\}$
 2 $\{x | 11 < x \leq 12, \text{ where } x \text{ is an integer}\}$
 3 $\{x | 10 \leq x < 12, \text{ where } x \text{ is an integer}\}$
 4 $\{x | 10 < x \leq 12, \text{ where } x \text{ is an integer}\}$
- 31 Which notation describes $\{1, 2, 3\}$?
 1 $\{x | 1 \leq x < 3, \text{ where } x \text{ is an integer}\}$
 2 $\{x | 0 < x \leq 3, \text{ where } x \text{ is an integer}\}$
 3 $\{x | 1 < x < 3, \text{ where } x \text{ is an integer}\}$
 4 $\{x | 0 \leq x \leq 3, \text{ where } x \text{ is an integer}\}$
- 32 In interval notation, the set of all real numbers greater than -6 and less than or equal to 14 is represented by
 1 $(-6, 14)$
 2 $[-6, 14)$
 3 $(-6, 14]$
 4 $[-6, 14]$
- 33 Which set builder notation describes $\{-2, -1, 0, 1, 2, 3\}$?
 1 $\{x | -3 \leq x \leq 3, \text{ where } x \text{ is an integer}\}$
 2 $\{x | -3 < x \leq 4, \text{ where } x \text{ is an integer}\}$
 3 $\{x | -2 < x < 3, \text{ where } x \text{ is an integer}\}$
 4 $\{x | -2 \leq x < 4, \text{ where } x \text{ is an integer}\}$

Integrated Algebra Regents Exam Questions by Performance Indicator: Topic

www.jmap.org

34 Which interval notation describes the set

$$S = \{x | 1 \leq x < 10\}?$$

- 1 [1, 10]
- 2 (1, 10]
- 3 [1, 10)
- 4 (1, 10)

35 The inequality $-2 \leq x \leq 3$ can be written as

- 1 $(-2, 3)$
- 2 $[-2, 3)$
- 3 $(-2, 3]$
- 4 $[-2, 3]$

36 Which interval notation represents $-3 \leq x \leq 3$?

- 1 $[-3, 3]$
- 2 $(-3, 3]$
- 3 $[-3, 3)$
- 4 $(-3, 3)$

37 Written in set-builder notation, $S = \{1, 3, 5, 7, 9\}$ is

- 1 $\{x | 1 < x < 9, \text{ where } x \text{ is a prime number}\}$
- 2 $\{x | 1 \leq x \leq 9, \text{ where } x \text{ is a prime number}\}$
- 3 $\{x | 1 < x < 9, \text{ where } x \text{ is an odd integer}\}$
- 4 $\{x | 1 \leq x \leq 9, \text{ where } x \text{ is an odd integer}\}$

38 Which notation is equivalent to the inequality

$$-3 < x \leq 7?$$

- 1 $[-3, 7]$
- 2 $(-3, 7]$
- 3 $[-3, 7)$
- 4 $(-3, 7)$

39 Which set of integers is included in $(-1, 3]$?

- 1 $\{0, 1, 2, 3\}$
- 2 $\{-1, 0, 1, 2\}$
- 3 $\{-1, 0, 1, 2, 3, 4\}$
- 4 $\{-2, -1, 0, 1, 2, 3\}$

40 The set of integers in $[6, 10)$ can be written as

- 1 $\{6, 7, 8, 9, 10\}$
- 2 $\{7, 8, 9, 10\}$
- 3 $\{6, 7, 8, 9\}$
- 4 $\{7, 8, 9\}$

A.A.30: SET THEORY

41 Consider the set of integers greater than -2 and less than 6 . A subset of this set is the positive factors of 5 . What is the complement of this subset?

- 1 $\{0, 2, 3, 4\}$
- 2 $\{-1, 0, 2, 3, 4\}$
- 3 $\{-2, -1, 0, 2, 3, 4, 6\}$
- 4 $\{-2, -1, 0, 1, 2, 3, 4, 5, 6\}$

42 Twelve players make up a high school basketball team. The team jerseys are numbered 1 through 12. The players wearing the jerseys numbered 3, 6, 7, 8, and 11 are the only players who start a game. Using set notation, list the complement of this subset.

43 Given:

$$A = \{\text{All even integers from 2 to 20, inclusive}\}$$

$$B = \{10, 12, 14, 16, 18\}$$

What is the complement of set B within the universe of set A ?

- 1 $\{4, 6, 8\}$
- 2 $\{2, 4, 6, 8\}$
- 3 $\{4, 6, 8, 20\}$
- 4 $\{2, 4, 6, 8, 20\}$

44 Given: Set $U = \{S, O, P, H, I, A\}$

$$\text{Set } B = \{A, I, O\}$$

If set B is a subset of set U , what is the complement of set B ?

- 1 $\{O, P, S\}$
- 2 $\{I, P, S\}$
- 3 $\{A, H, P\}$
- 4 $\{H, P, S\}$

Integrated Algebra Regents Exam Questions by Performance Indicator: Topic

www.jmap.org

- 45 Given: $U = \{1, 2, 3, 4, 5, 6, 7, 8\}$
 $B = \{2, 3, 5, 6\}$
 Set B is a subset of set U . What is the complement of set B ?
- 1 $\{ \}$
 - 2 $\{2, 3, 5, 6\}$
 - 3 $\{1, 4, 7, 8\}$
 - 4 $\{1, 2, 3, 4, 5, 6, 7, 8\}$

- 46 If the universal set is {pennies, nickels, dimes, quarters}, what is the complement of the set {nickels}?
- 1 $\{ \}$
 - 2 {pennies, quarters}
 - 3 {pennies, dimes, quarters}
 - 4 {pennies, nickels, dimes, quarters}

- 47 Given:
 $A = \{\text{perfect square integers from 4-100, inclusive}\}$
 $B = \{16, 36, 49, 64\}$
 The complement of set B in the universal set A is
- 1 $\{9, 25, 81\}$
 - 2 $\{4, 9, 25, 81, 100\}$
 - 3 $\{1, 4, 9, 25, 81, 100\}$
 - 4 $\{4, 16, 36, 49, 64, 100\}$

- 48 Given:
 $A = \{\text{all odd integers from 1 through 19, inclusive}\}$
 $B = \{9, 11, 13, 15, 17\}$
 What is the complement of set B within set A ?
- 1 $\{3, 5, 7\}$
 - 2 $\{3, 5, 7, 19\}$
 - 3 $\{1, 3, 5, 7\}$
 - 4 $\{1, 3, 5, 7, 19\}$

- 49 Given: $U = \{x | 0 < x < 10 \text{ and } x \text{ is an integer}\}$
 $S = \{x | 0 < x < 10 \text{ and } x \text{ is an odd integer}\}$
 The complement of set S within the universal set U is
- 1 $\{0, 2, 4, 6, 8, 10\}$
 - 2 $\{2, 4, 6, 8, 10\}$
 - 3 $\{0, 2, 4, 6, 8\}$
 - 4 $\{2, 4, 6, 8\}$

A.A.31: SET THEORY

- 50 Given:
 Set $A = \{(-2, -1), (-1, 0), (1, 8)\}$
 Set $B = \{(-3, -4), (-2, -1), (-1, 2), (1, 8)\}$.
 What is the intersection of sets A and B ?
- 1 $\{(1, 8)\}$
 - 2 $\{(-2, -1)\}$
 - 3 $\{(-2, -1), (1, 8)\}$
 - 4 $\{(-3, -4), (-2, -1), (-1, 2), (-1, 0), (1, 8)\}$

- 51 Maureen tracks the range of outdoor temperatures over three days. She records the following information.

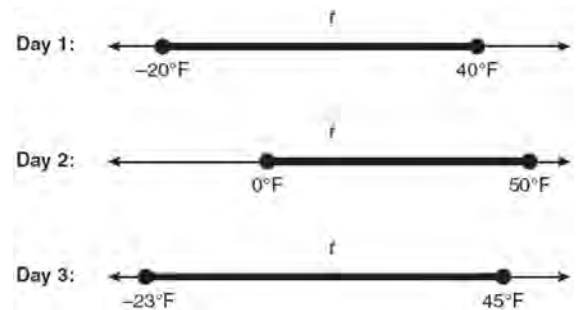

Express the intersection of the three sets as an inequality in terms of temperature, t .

Integrated Algebra Regents Exam Questions by Performance Indicator: Topic

www.jmap.org

52 Given: $Q = \{0, 2, 4, 6\}$

$W = \{0, 1, 2, 3\}$

$Z = \{1, 2, 3, 4\}$

What is the intersection of sets Q , W , and Z ?

- 1 $\{2\}$
- 2 $\{0, 2\}$
- 3 $\{1, 2, 3\}$
- 4 $\{0, 1, 2, 3, 4, 6\}$

53 Which set represents the intersection of sets A , B , and C shown in the diagram below?

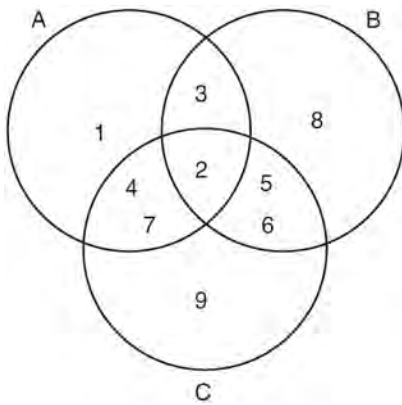

- 1 $\{3, 4, 5, 6, 7\}$
- 2 $\{2\}$
- 3 $\{2, 3, 4, 5, 6, 7\}$
- 4 $\{1, 2, 3, 4, 5, 6, 7, 8, 9\}$

54 Given: $X = \{1, 2, 3, 4\}$

$Y = \{2, 3, 4, 5\}$

$Z = \{3, 4, 5, 6\}$

What is the intersection of sets X , Y , and Z ?

- 1 $\{3, 4\}$
- 2 $\{2, 3, 4\}$
- 3 $\{3, 4, 5\}$
- 4 $\{1, 2, 3, 4, 5, 6\}$

55 Given: $A = \{3, 6, 9, 12, 15\}$

$B = \{2, 4, 6, 8, 10, 12\}$

What is the union of sets A and B ?

- 1 $\{6\}$
- 2 $\{6, 12\}$
- 3 $\{2, 3, 4, 8, 9, 10, 15\}$
- 4 $\{2, 3, 4, 6, 8, 9, 10, 12, 15\}$

56 Given: $A = \{2, 4, 5, 7, 8\}$

$B = \{3, 5, 8, 9\}$

What is $A \cup B$?

- 1 $\{5\}$
- 2 $\{5, 8\}$
- 3 $\{2, 3, 4, 7, 9\}$
- 4 $\{2, 3, 4, 5, 7, 8, 9\}$

57 If $A = \{0, 1, 3, 4, 6, 7\}$, $B = \{0, 2, 3, 5, 6\}$, and $C = \{0, 1, 4, 6, 7\}$, then $A \cap B \cap C$ is

- 1 $\{0, 1, 2, 3, 4, 5, 6, 7\}$
- 2 $\{0, 3, 6\}$
- 3 $\{0, 6\}$
- 4 $\{0\}$

58 Given: $A = \{1, 3, 5, 7, 9\}$

$B = \{2, 4, 6, 8, 10\}$

$C = \{2, 3, 5, 7\}$

$D = \{1, 2, 3, 4, 5, 6, 7, 8, 9, 10\}$

What statement is *false*?

- 1 $A \cup B \cup C = D$
- 2 $A \cap B \cap C = \{ \}$
- 3 $A \cup C = \{1, 2, 3, 5, 7\}$
- 4 $A \cap C = \{3, 5, 7\}$

59 Given: $R = \{1, 2, 3, 4\}$

$A = \{0, 2, 4, 6\}$

$P = \{1, 3, 5, 7\}$

What is $R \cap P$?

1 $\{0, 1, 2, 3, 4, 5, 6, 7\}$

2 $\{1, 2, 3, 4, 5, 7\}$

3 $\{1, 3\}$

4 $\{2, 4\}$

60 Given: $M = \{\text{green, red, yellow, black}\}$

$N = \{\text{blue, green, yellow}\}$

Which set represents $M \cup N$?

1 $\{\text{yellow}\}$

2 $\{\text{green, yellow}\}$

3 $\{\text{blue, red, black}\}$

4 $\{\text{green, red, yellow, blue, black}\}$

61 Given the following:

$A = \{\text{Charles, Kyle, Nakim, Jade}\}$

$B = \{\text{Charles, Jade, Alicia, Kyle}\}$

$C = \{\text{Kyle, Nakim, Jade, Dylan}\}$

What is the intersection of sets A , B , and C ?

1 $\{\text{Kyle, Nakim}\}$

2 $\{\text{Charles, Kyle}\}$

3 $\{\text{Jade, Nakim}\}$

4 $\{\text{Jade, Kyle}\}$

62 If $A = \{1, 2, 3, 4, 5, 6, 7, 8\}$ and

$B = \{2, 4, 6, 8, 10, 12\}$, the intersection of sets A and B is

1 $\{10, 12\}$

2 $\{2, 4, 6, 8\}$

3 $\{1, 3, 5, 7\}$

4 $\{1, 2, 3, 4, 5, 6, 7, 8, 10, 12\}$

63 If $A = \{1, 2, 3, 4, 5, 6, 7, 8\}$ and

$B = \{2, 4, 6, 8, 10, 12\}$, then the intersection of these two sets is

1 $\{10, 12\}$

2 $\{1, 3, 5, 7\}$

3 $\{2, 4, 6, 8\}$

4 $\{1, 2, 3, 4, 5, 6, 7, 8, 10, 12\}$

GRAPHS AND STATISTICS

A.S.5: FREQUENCY HISTOGRAMS, BAR GRAPHS AND TABLES

64 Twenty students were surveyed about the number of days they played outside in one week. The results of this survey are shown below.

$\{6, 5, 4, 3, 0, 7, 1, 5, 4, 4, 3, 2, 2, 3, 2, 4, 3, 4, 0, 7\}$

Complete the frequency table below for these data.

Interval	Tally	Frequency
0–1		
2–3		
4–5		
6–7		

Complete the cumulative frequency table below using these data.

Number of Days Outside

Interval	Cumulative Frequency
0–1	
0–3	
0–5	
0–7	

On the grid below, create a cumulative frequency histogram based on the table you made.

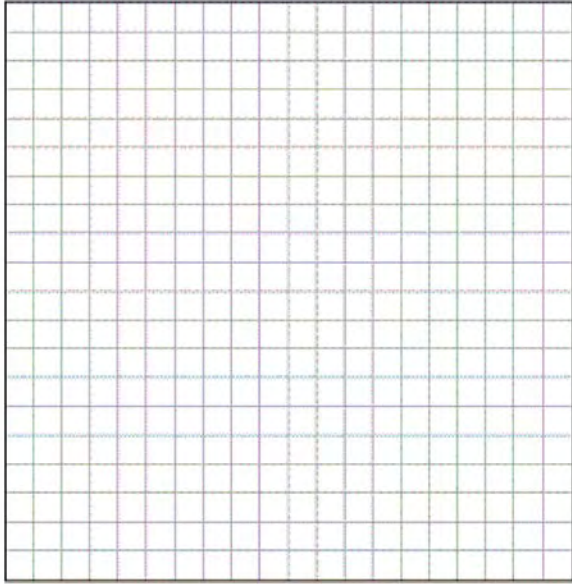

65 The Fahrenheit temperature readings on 30 April mornings in Stormville, New York, are shown below.

41°, 58°, 61°, 54°, 49°, 46°, 52°, 58°, 67°, 43°,
 47°, 60°, 52°, 58°, 48°, 44°, 59°, 66°, 62°, 55°,
 44°, 49°, 62°, 61°, 59°, 54°, 57°, 58°, 63°, 60°

Using the data, complete the frequency table below.

Interval	Tally	Frequency
40–44		
45–49		
50–54		
55–59		
60–64		
65–69		

On the grid below, construct and label a frequency histogram based on the table.

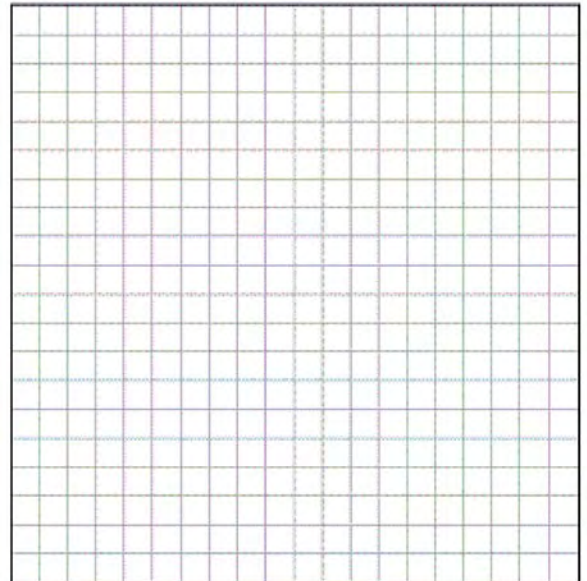

- 66 The test scores for 18 students in Ms. Mosher’s class are listed below:

86, 81, 79, 71, 58, 87, 52, 71, 87,
 87, 93, 64, 94, 81, 76, 98, 94, 68

Complete the frequency table below.

Interval	Tally	Frequency
51–60		
61–70		
71–80		
81–90		
91–100		

Draw and label a frequency histogram on the grid below.

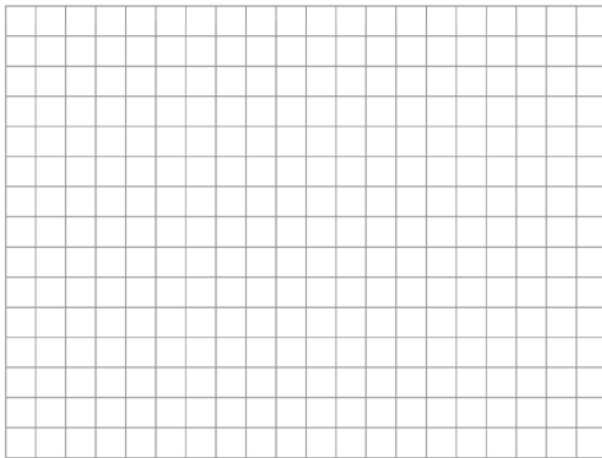

- 67 Ms. Hopkins recorded her students' final exam scores in the frequency table below.

Interval	Tally	Frequency
61–70	###	5
71–80		4
81–90	###	9
91–100	###	6

On the grid below, construct a frequency histogram based on the table.

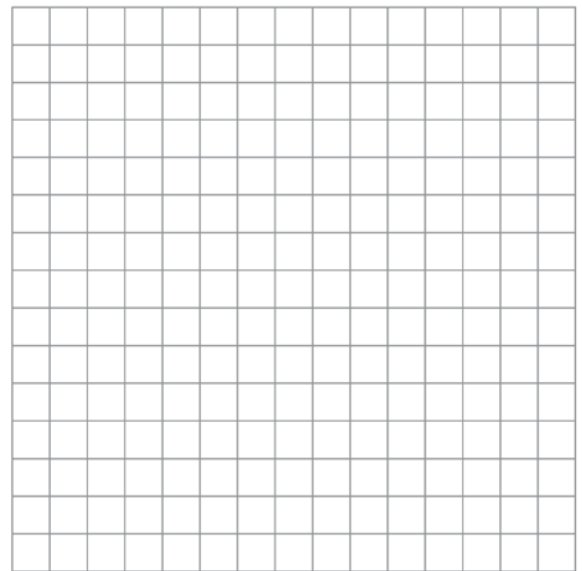

- 68 Mr. Suppe recorded the height, in inches, of each student in his class. The results are recorded in the table below.

60	59	70	65	64
61	58	72	75	66
65	67	63	62	68
68	69	74	61	70

Which cumulative frequency histogram represents the data?

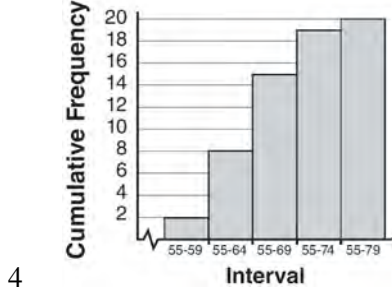
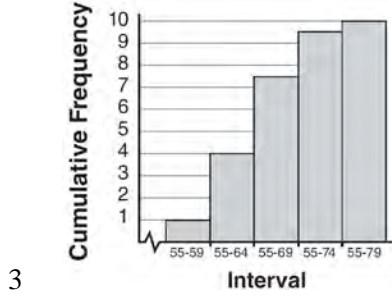
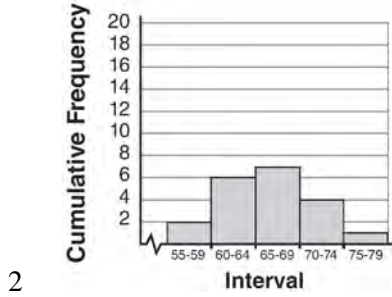
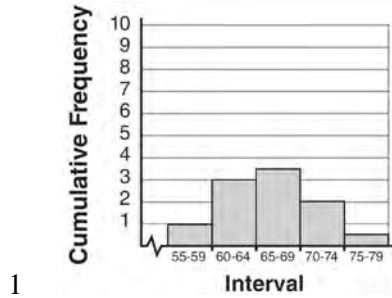

69 The following set of data represents the heights, in inches, of the 20 students in Ms. Fitzgerald's freshman class:

63, 56, 67, 59, 70, 69, 62, 74, 66, 72

67, 60, 70, 66, 67, 58, 68, 72, 63, 67

Complete the frequency table below.

Heights of Students

Interval	Tally	Frequency
55-59		
60-64		
65-69		
70-74		

On the grid below, draw and label a frequency histogram for these data.

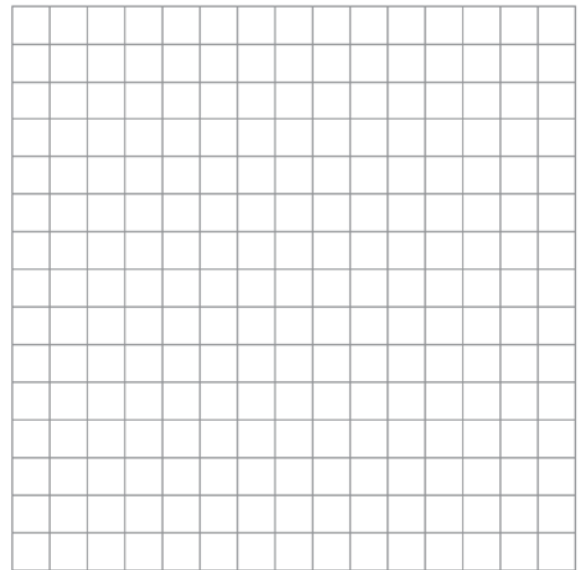

A.S.9: FREQUENCY HISTOGRAMS, BAR GRAPHS AND TABLES

70 The table below shows a cumulative frequency distribution of runners' ages.

Cumulative Frequency Distribution of Runners' Ages

Age Group	Total
20-29	8
20-39	18
20-49	25
20-59	31
20-69	35

According to the table, how many runners are in their forties?

- 1 25
- 2 10
- 3 7
- 4 6

71 The diagram below shows a cumulative frequency histogram of the students' test scores in Ms. Wedow's algebra class.

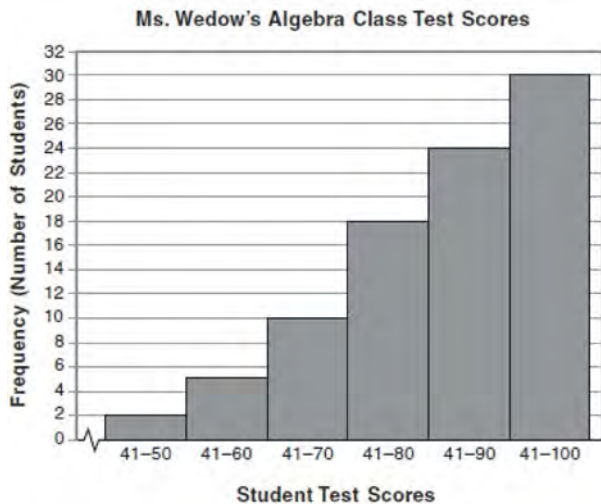

Determine the total number of students in the class. Determine how many students scored higher than 70. State which *ten-point interval* contains the median. State which *two ten-point intervals* contain the same frequency.

72 The cumulative frequency table below shows the length of time that 30 students spent text messaging on a weekend.

Minutes Used	Cumulative Frequency
31-40	2
31-50	5
31-60	10
31-70	19
31-80	30

Which 10-minute interval contains the first quartile?

- 1 31 – 40
- 2 41 – 50
- 3 51 – 60
- 4 61 – 70

- 73 The following cumulative frequency histogram shows the distances swimmers completed in a recent swim test.

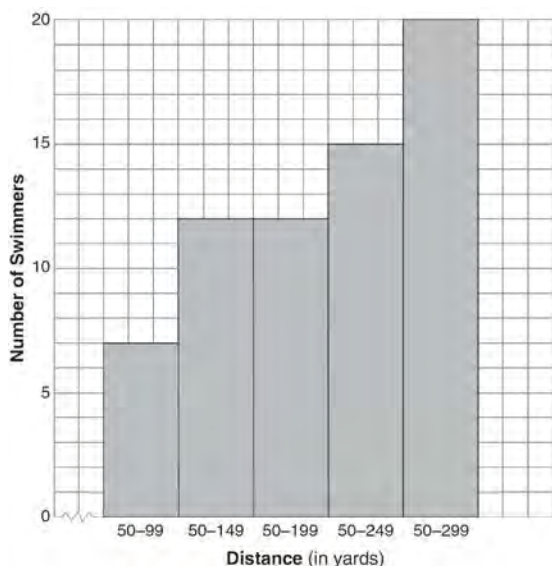

Based on the cumulative frequency histogram, determine the number of swimmers who swam between 200 and 249 yards. Determine the number of swimmers who swam between 150 and 199 yards. Determine the number of swimmers who took the swim test.

- 74 The cumulative frequency table below shows the number of minutes 31 students spent text messaging on a weekend.

Text-Use Interval (minutes)	Cumulative Frequency
41-50	2
41-60	5
41-70	10
41-80	19
41-90	31

Determine which 10-minute interval contains the median. Justify your choice.

A.S.5: BOX-AND-WHISKER PLOTS

- 75 The data set 5, 6, 7, 8, 9, 9, 9, 10, 12, 14, 17, 17, 18, 19, 19 represents the number of hours spent on the Internet in a week by students in a mathematics class. Which box-and-whisker plot represents the data?

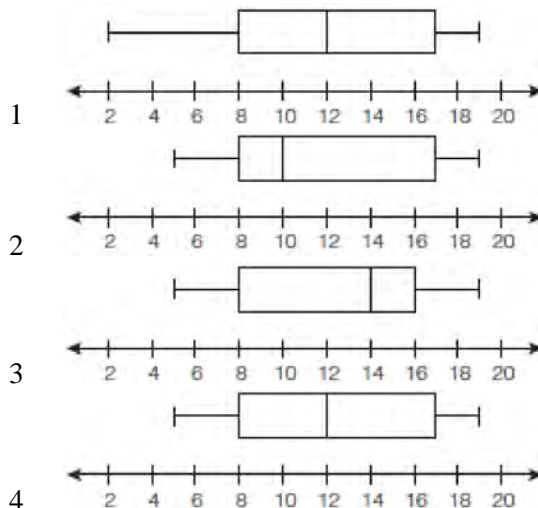

- 76 The test scores from Mrs. Gray's math class are shown below.

72, 73, 66, 71, 82, 85, 95, 85, 86, 89, 91, 92

Construct a box-and-whisker plot to display these data.

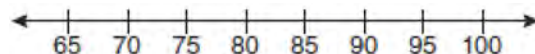

- 77 The number of songs fifteen students have on their MP3 players is:

120, 124, 132, 145, 200, 255, 260, 292, 308, 314, 342, 407, 421, 435, 452

State the values of the minimum, 1st quartile, median, 3rd quartile, and maximum. Using these values, construct a box-and-whisker plot using an appropriate scale on the line below.

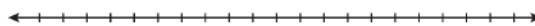

- 78 Using the line provided, construct a box-and-whisker plot for the 12 scores below.
26, 32, 19, 65, 57, 16, 28, 42, 40, 21, 38, 10



Determine the number of scores that lie above the 75th percentile.

- 79 During the last 15 years of his baseball career, Andrew hit the following number of home runs each season.
35, 24, 32, 36, 40, 32, 40, 38, 36, 33, 11, 20, 19, 22, 8
State and label the values of the minimum, 1st quartile, median, 3rd quartile, and maximum.
Using the line below, construct a box-and-whisker plot for this set of data.

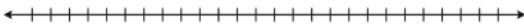

- 80 Using his data on annual deer population in a forest, Noj found the following information:
25th percentile: 12
50th percentile: 15
75th percentile: 22
Minimum population: 8
Maximum population: 27
Using the number line below, construct a box-and-whisker plot to display these data.

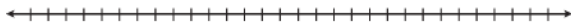

A.S.6: BOX-AND-WHISKER PLOTS

- 81 What is the value of the third quartile shown on the box-and-whisker plot below?

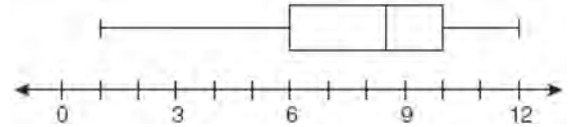

- 1 6
2 8.5
3 10
4 12
- 82 A movie theater recorded the number of tickets sold daily for a popular movie during the month of June. The box-and-whisker plot shown below represents the data for the number of tickets sold, in hundreds.

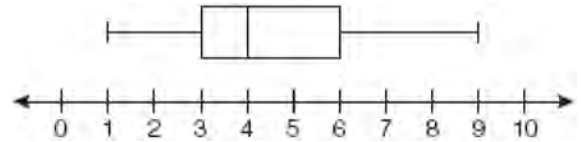

Which conclusion can be made using this plot?

- 1 The second quartile is 600.
2 The mean of the attendance is 400.
3 The range of the attendance is 300 to 600.
4 Twenty-five percent of the attendance is between 300 and 400.
- 83 The box-and-whisker plot below represents students' scores on a recent English test.

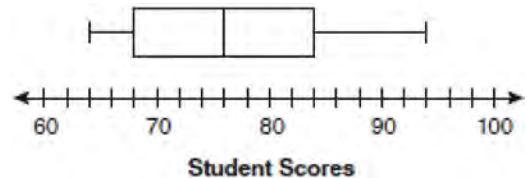

What is the value of the upper quartile?

- 1 68
2 76
3 84
4 94

Integrated Algebra Regents Exam Questions by Performance Indicator: Topic

www.jmap.org

- 84 The box-and-whisker plot below represents the math test scores of 20 students.

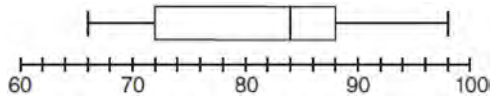

What percentage of the test scores are *less than* 72?

- 1 25
 - 2 50
 - 3 75
 - 4 100
- 85 What is the range of the data represented in the box-and-whisker plot shown below?

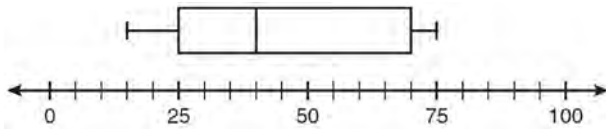

- 1 40
- 2 45
- 3 60
- 4 100

- 86 Based on the box-and-whisker plot below, which statement is *false*?

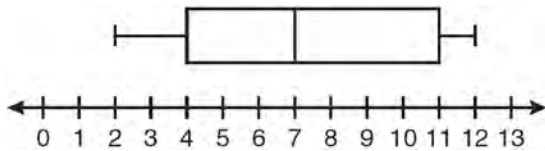

- 1 The median is 7.
- 2 The range is 12.
- 3 The first quartile is 4.
- 4 The third quartile is 11.

- 87 The box-and-whisker plot below represents the ages of 12 people.

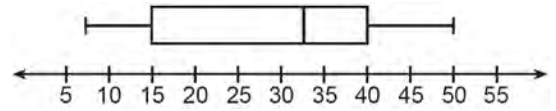

What percentage of these people are age 15 or older?

- 1 25
- 2 35
- 3 75
- 4 85

- 88 The box-and-whisker plot below represents the results of tests scores in a math class.

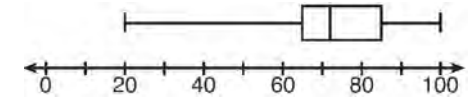

What do the scores 65, 85, and 100 represent?

- 1 Q_1 , median, Q_3
- 2 Q_1 , Q_3 , maximum
- 3 median, Q_1 , maximum
- 4 minimum, median, maximum

- 89 The box-and-whisker plot below represents a set of grades in a college statistics class.

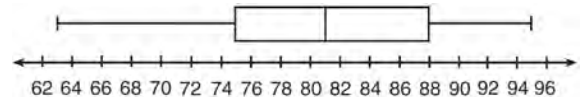

Which interval contains exactly 50% of the grades?

- 1 63-88
- 2 63-95
- 3 75-81
- 4 75-88

- 90 The box-and-whisker plot shown below represents the number of magazine subscriptions sold by members of a club.

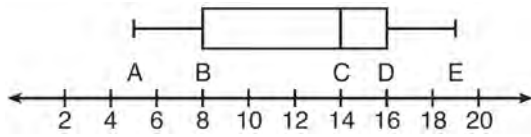

Which statistical measures do points B , D , and E represent, respectively?

- 1 minimum, median, maximum
 - 2 first quartile, median, third quartile
 - 3 first quartile, third quartile, maximum
 - 4 median, third quartile, maximum
- 91 In the box-and-whisker plot below, what is the 2nd quartile?

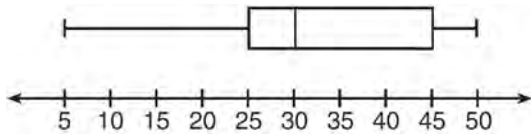

- 1 25
- 2 30
- 3 45
- 4 50

A.S.11: QUARTILES AND PERCENTILES

- 92 The freshman class held a canned food drive for 12 weeks. The results are summarized in the table below.

Canned Food Drive Results

Week	1	2	3	4	5	6	7	8	9	10	11	12
Number of Cans	20	35	32	45	58	46	28	23	31	79	65	62

Which number represents the second quartile of the number of cans of food collected?

- 1 29.5
- 2 30.5
- 3 40
- 4 60

- 93 Brianna's score on a national math assessment exceeded the scores of 95,000 of the 125,000 students who took the assessment. What was her percentile rank?

- 1 6
- 2 24
- 3 31
- 4 76

- 94 The weights of 40 students were recorded. If the 75th percentile of their weights was 140 pounds, what is the total number of students who weighed *more than* 140 pounds?

- 1 10
- 2 20
- 3 30
- 4 4

A.S.7: SCATTER PLOTS

- 95 For 10 days, Romero kept a record of the number of hours he spent listening to music. The information is shown in the table below.

Day	1	2	3	4	5	6	7	8	9	10
Hours	9	3	2	6	8	6	10	4	5	2

Which scatter plot shows Romero's data graphically?

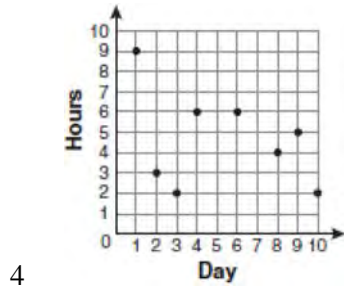
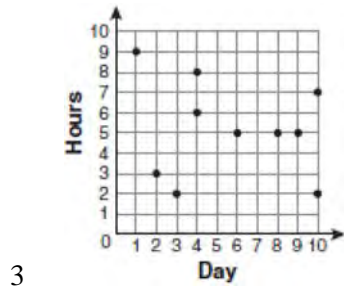
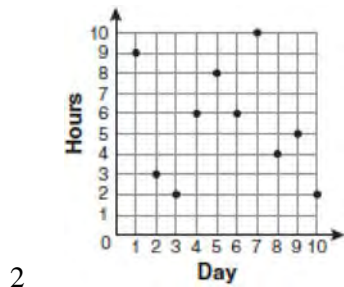
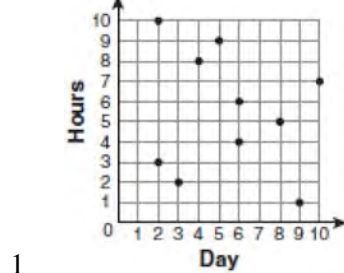

- 96 The school store did a study comparing the cost of a sweatshirt with the number of sweatshirts sold. The price was changed several times and the numbers of sweatshirts sold were recorded. The data are shown in the table below.

Cost of Sweatshirt	\$10	\$25	\$15	\$20	\$5
Number Sold	9	6	15	11	14

Which scatter plot represents the data?

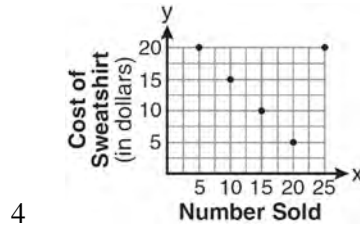
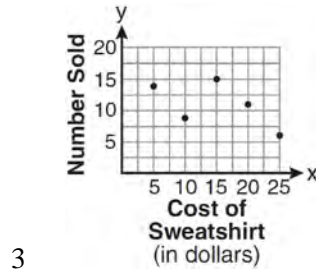
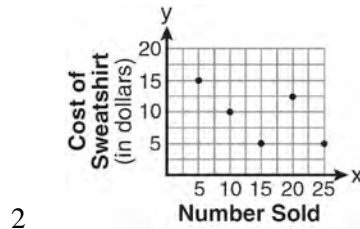
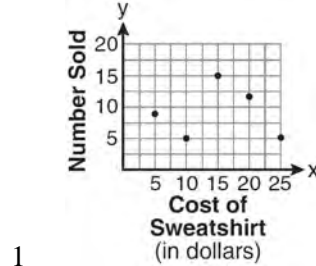

- 97 The maximum height and speed of various roller coasters in North America are shown in the table below.

Maximum Speed, in mph, (x)	45	50	54	60	65	70
Maximum Height, in feet, (y)	63	80	105	118	141	107

Which graph represents a correct scatter plot of the data?

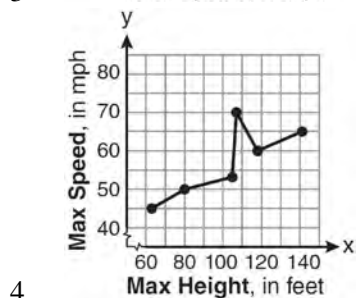
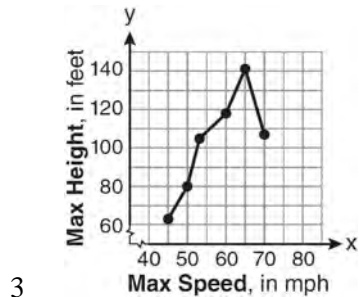
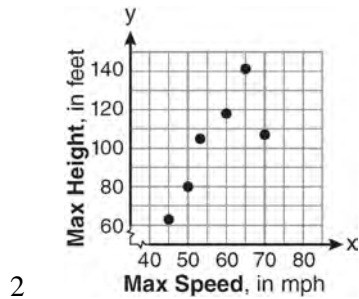
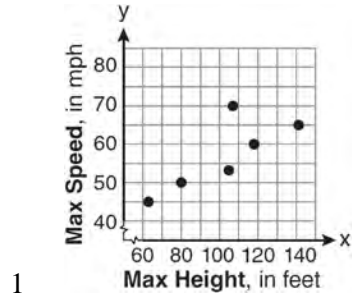

A.S.8: SCATTER PLOTS

- 98 Which equation most closely represents the line of best fit for the scatter plot below?



- 1 $y = x$
- 2 $y = \frac{2}{3}x + 1$
- 3 $y = \frac{3}{2}x + 4$
- 4 $y = \frac{3}{2}x + 1$

99 The table below shows the number of prom tickets sold over a ten-day period.

Prom Ticket Sales

Day (x)	1	2	5	7	10
Number of Prom Tickets Sold (y)	30	35	55	60	70

Plot these data points on the coordinate grid below. Use a consistent and appropriate scale. Draw a reasonable line of best fit and write its equation.

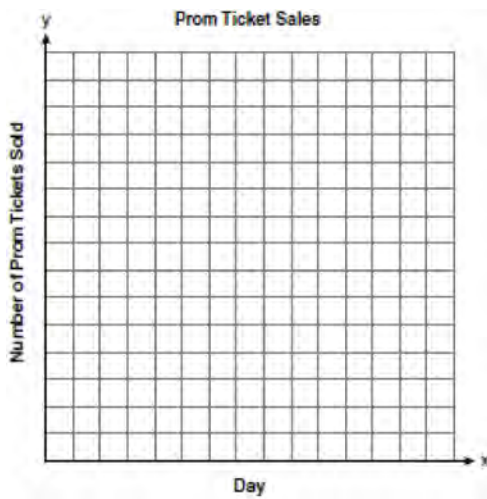

100 A scatter plot was constructed on the graph below and a line of best fit was drawn.

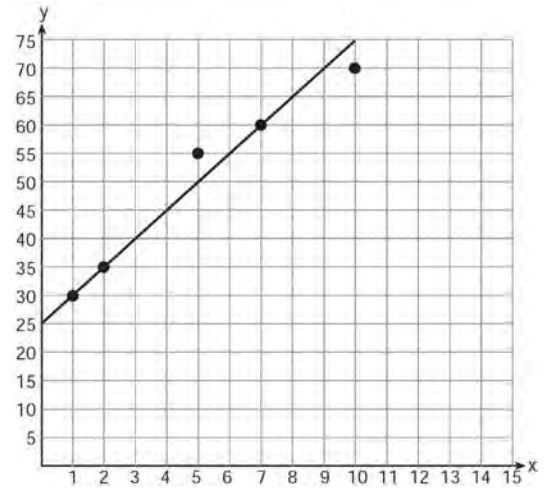

What is the equation of this line of best fit?

- 1 $y = x + 5$
- 2 $y = x + 25$
- 3 $y = 5x + 5$
- 4 $y = 5x + 25$

101 There is a negative correlation between the number of hours a student watches television and his or her social studies test score. Which scatter plot below displays this correlation?

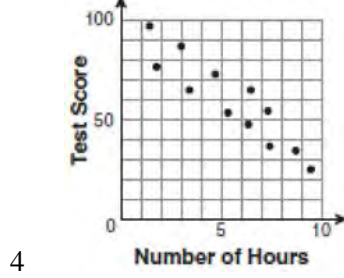
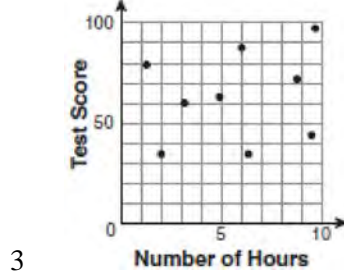
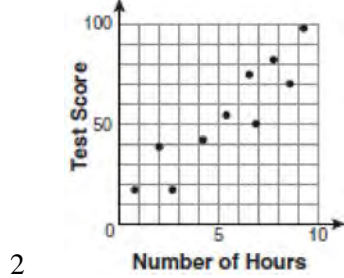
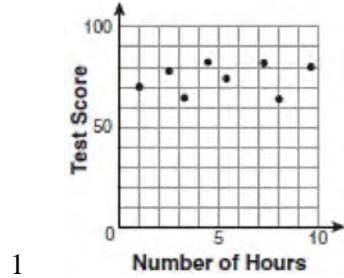

102 Which scatter plot shows the relationship between x and y if x represents a student score on a test and y represents the number of incorrect answers a student received on the same test?

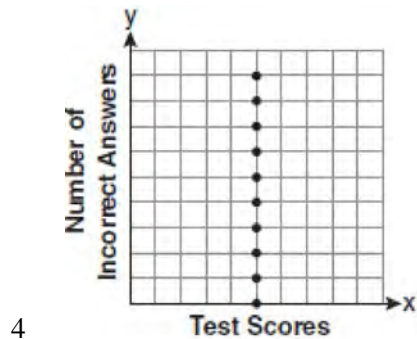
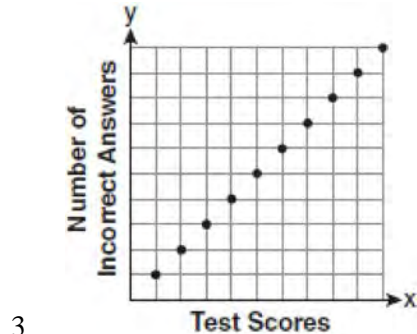
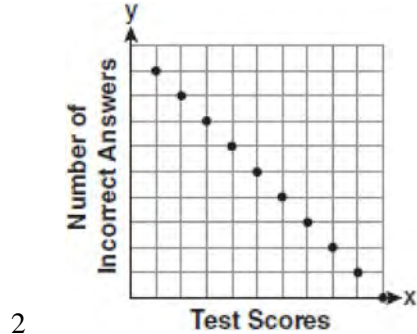
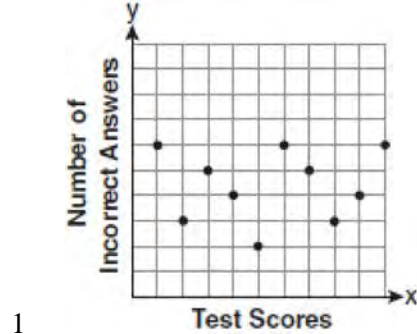

103 What is the relationship between the independent and dependent variables in the scatter plot shown below?

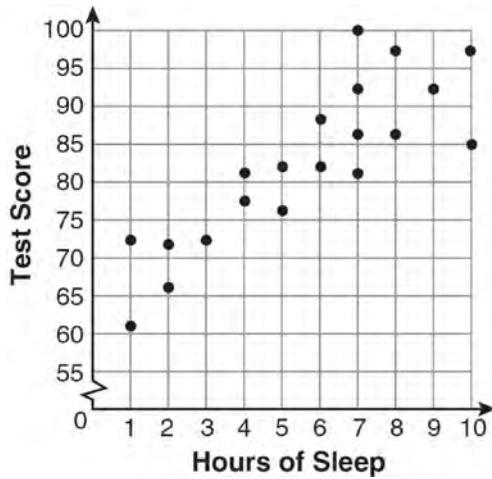

- 1 undefined correlation
- 2 negative correlation
- 3 positive correlation
- 4 no correlation

104 The scatter plot below represents the relationship between the number of peanuts a student eats and the student's bowling score.

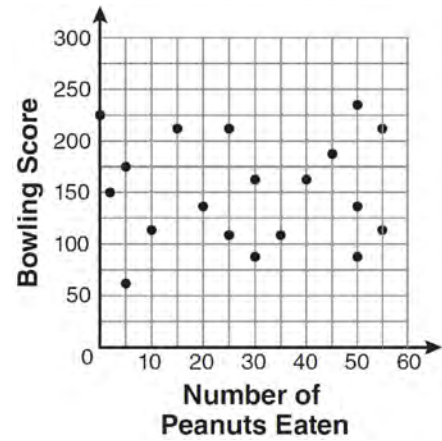

Which conclusion about the scatter plot is valid?

- 1 There is almost no relationship between eating peanuts and bowling score.
- 2 Students who eat more peanuts have higher bowling scores.
- 3 Students who eat more peanuts have lower bowling scores.
- 4 No bowlers eat peanuts.

105 A set of data is graphed on the scatter plot below.

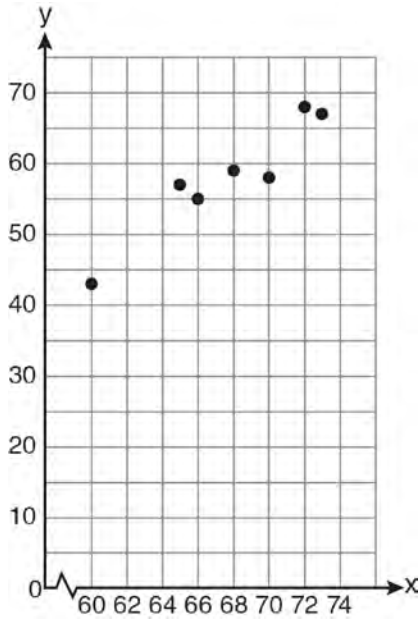

This scatter plot shows

- 1 no correlation
- 2 positive correlation
- 3 negative correlation
- 4 undefined correlation

106 The scatter plot shown below represents a relationship between x and y .

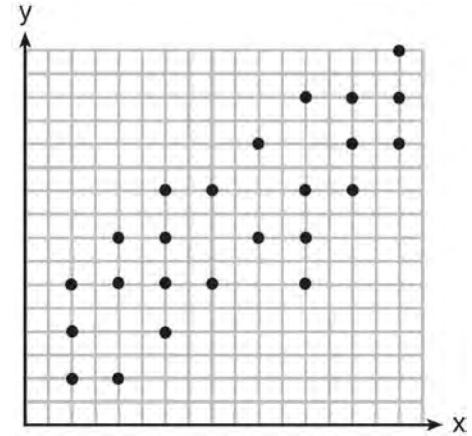

This type of relationship is

- 1 a positive correlation
- 2 a negative correlation
- 3 a zero correlation
- 4 not able to be determined

- 107 The number of hours spent on math homework during one week and the math exam grades for eleven students in Ms. Smith’s algebra class are plotted below.

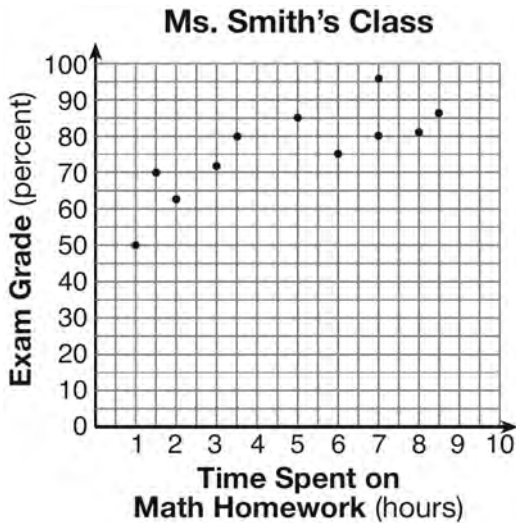

Based on the plotted data, what is the correlation between the time spent on homework and the exam grade?

- 1 positive
 - 2 negative
 - 3 no correlation
 - 4 cannot be determined
- 108 Which situation describes a negative correlation?
- 1 the amount of gas left in a car's tank and the amount of gas used from it
 - 2 the number of gallons of gas purchased and the amount paid for the gas
 - 3 the size of a car's gas tank and the number of gallons it holds
 - 4 the number of miles driven and the amount of gas used
- 109 A positive correlation always exists on a scatter plot when
- 1 y remains unchanged as x increases
 - 2 y changes randomly as x increases
 - 3 y decreases as x increases
 - 4 y increases as x increases

- 110 Which statement is true about the data shown in the scatter plot below?

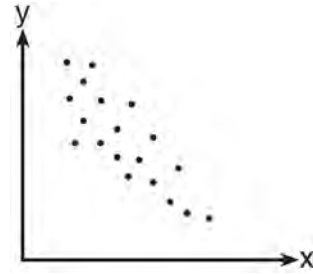

- 1 There is no correlation between the two sets of data.
- 2 There is a positive correlation between the two sets of data.
- 3 There is a negative correlation between the two sets of data.
- 4 The correlation between the data is both positive and negative.

A.S.17: SCATTER PLOTS

- 111 The number of hours spent on math homework each week and the final exam grades for twelve students in Mr. Dylan's algebra class are plotted below.

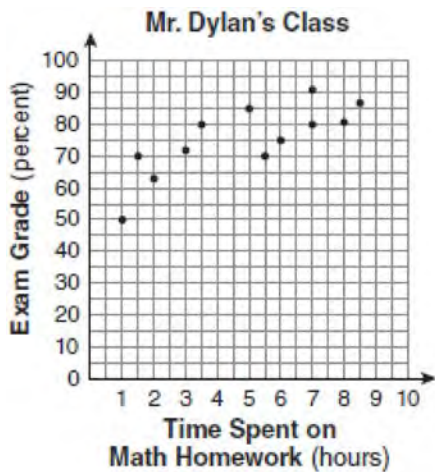

Based on a line of best fit, which exam grade is the best prediction for a student who spends about 4 hours on math homework each week?

- 1 62
- 2 72
- 3 82
- 4 92

- 112 Megan and Bryce opened a new store called the Donut Pit. Their goal is to reach a profit of \$20,000 in their 18th month of business. The table and scatter plot below represent the profit, P , in thousands of dollars, that they made during the first 12 months.

t (months)	P (profit, in thousands of dollars)
1	3.0
2	2.5
3	4.0
4	5.0
5	6.5
6	5.5
7	7.0
8	6.0
9	7.5
10	7.0
11	9.0
12	9.5

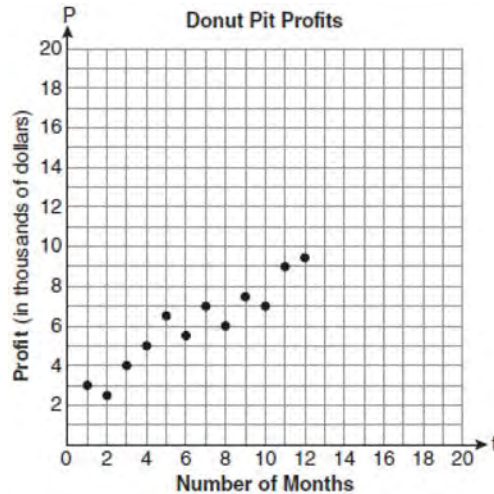

Draw a reasonable line of best fit. Using the line of best fit, predict whether Megan and Bryce will reach their goal in the 18th month of their business. Justify your answer.

- 113 The scatter plot below shows the profit, by month, for a new company for the first year of operation. Kate drew a line of best fit, as shown in the diagram.

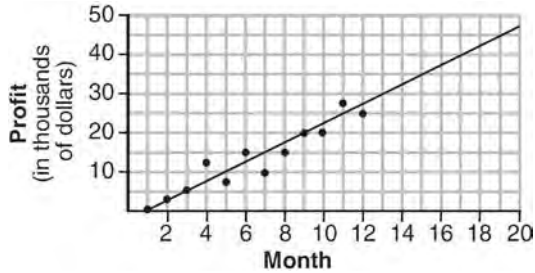

Using this line, what is the best estimate for profit in the 18th month?

- 1 \$35,000
 - 2 \$37,750
 - 3 \$42,500
 - 4 \$45,000
- 114 Based on the line of best fit drawn below, which value could be expected for the data in June 2015?

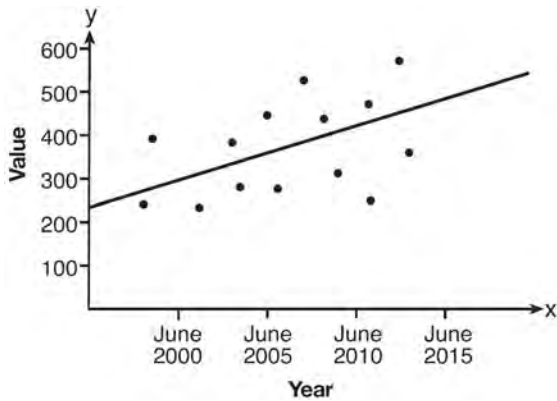

- 1 230
- 2 310
- 3 480
- 4 540

- 115 The graph below illustrates the number of acres used for farming in Smalltown, New York, over several years.

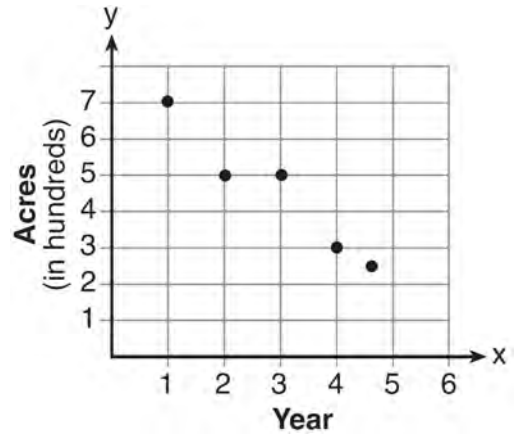

Using a line of best fit, approximately how many acres will be used for farming in the 5th year?

- 1 0
- 2 200
- 3 300
- 4 400

A.S.4: CENTRAL TENDENCY

- 116 The values of 11 houses on Washington St. are shown in the table below.

Value per House	Number of Houses
\$100,000	1
\$175,000	5
\$200,000	4
\$700,000	1

Find the mean value of these houses in dollars.
 Find the median value of these houses in dollars.
 State which measure of central tendency, the mean or the median, *best* represents the values of these 11 houses. Justify your answer.

- 117 The prices of seven race cars sold last week are listed in the table below.

Price per Race Car	Number of Race Cars
\$126,000	1
\$140,000	2
\$180,000	1
\$400,000	2
\$819,000	1

What is the mean value of these race cars, in dollars? What is the median value of these race cars, in dollars? State which of these measures of central tendency best represents the value of the seven race cars. Justify your answer.

- 118 Which statement is true about the data set 3, 4, 5, 6, 7, 7, 10?

- 1 mean = mode
- 2 mean > mode
- 3 mean = median
- 4 mean < median

- 119 Alex earned scores of 60, 74, 82, 87, 87, and 94 on his first six algebra tests. What is the relationship between the measures of central tendency of these scores?

- 1 median < mode < mean
- 2 mean < mode < median
- 3 mode < median < mean
- 4 mean < median < mode

- 120 Sam's grades on eleven chemistry tests were 90, 85, 76, 63, 94, 89, 81, 76, 78, 69, and 97. Which statement is true about the measures of central tendency?

- 1 mean > mode
- 2 mean < median
- 3 mode > median
- 4 median = mean

- 121 Which statement is true about the data set 4, 5, 6, 6, 7, 9, 12?

- 1 mean = mode
- 2 mode = median
- 3 mean < median
- 4 mode > mean

- 122 Kelsey scored the following points in her first six basketball games: 22, 14, 19, 22, 8, and 17. What is the relationship between the measures of central tendency of these data?

- 1 mode > median > mean
- 2 median > mode > mean
- 3 mean > median > mode
- 4 mode > mean > median

- 123 Mrs. Porter recorded her students' grades in the frequency table below.

Score	Frequency
96	2
92	5
88	3
84	2
78	4
60	1

Which statement is true for the data?

- 1 mean > median > mode
- 2 mean > mode > median
- 3 mode > median > mean
- 4 median > mean > mode

A.S.16: CENTRAL TENDENCY

- 124 Ms. Mosher recorded the math test scores of six students in the table below.

Student	Student Score
Andrew	72
John	80
George	85
Amber	93
Betty	78
Roberto	80

Determine the mean of the student scores, to the *nearest tenth*. Determine the median of the student scores. Describe the effect on the mean and the median if Ms. Mosher adds 5 bonus points to each of the six students' scores.

- 125 Given the following list of students' scores on a quiz:

5, 12, 7, 15, 20, 14, 7

Determine the median of these scores. Determine the mode of these scores. The teacher decides to adjust these scores by adding three points to each score. Explain the effect, if any, that this will have on the median and mode of these scores.

- 126 Mr. Taylor raised all his students' scores on a recent test by five points. How were the mean and the range of the scores affected?
- 1 The mean increased by five and the range increased by five.
 - 2 The mean increased by five and the range remained the same.
 - 3 The mean remained the same and the range increased by five.
 - 4 The mean remained the same and the range remained the same.

A.S.16: AVERAGE KNOWN WITH MISSING DATA

- 127 This year, John played in 10 baseball games. In these games he had hit the ball 2, 3, 0, 1, 3, 2, 4, 0, 2, and 3 times. In the first 10 games he plays next year, John wants to increase his average (mean) hits per game by 0.5. What is the total number of hits John needs over the first 10 games next year to achieve his goal?
- 1 5
 - 2 2
 - 3 20
 - 4 25

- 128 Noj has the following test scores:
76, 84, 69, 74, 91

His teacher will allow him to retake the test on which he scored lowest. Noj wants an average of *at least* 82. Determine the *least* number of additional points Noj must score on the retest.

A.S.1: ANALYSIS OF DATA

- 129 Which data set describes a situation that could be classified as qualitative?
- 1 the elevations of the five highest mountains in the world
 - 2 the ages of presidents at the time of their inauguration
 - 3 the opinions of students regarding school lunches
 - 4 the shoe sizes of players on the basketball team
- 130 Which data set describes a situation that could be classified as qualitative?
- 1 the ages of the students in Ms. Marshall's Spanish class
 - 2 the test scores of the students in Ms. Fitzgerald's class
 - 3 the favorite ice cream flavor of each of Mr. Hayden's students
 - 4 the heights of the players on the East High School basketball team

Integrated Algebra Regents Exam Questions by Performance Indicator: Topic

www.jmap.org

- 131 Which data set describes a situation that could be classified as quantitative?
- 1 the phone numbers in a telephone book
 - 2 the addresses for students at Hopkins High School
 - 3 the zip codes of residents in the city of Buffalo, New York
 - 4 the time it takes each of Mr. Harper's students to complete a test
- 132 Which set of data can be classified as qualitative?
- 1 scores of students in an algebra class
 - 2 ages of students in a biology class
 - 3 numbers of students in history classes
 - 4 eye colors of students in an economics class
- 133 Which set of data can be classified as quantitative?
- 1 first names of students in a chess club
 - 2 ages of students in a government class
 - 3 hair colors of students in a debate club
 - 4 favorite sports of students in a gym class
- 134 Craig sees an advertisement for a car in a newspaper. Which information would *not* be classified as quantitative?
- 1 the cost of the car
 - 2 the car's mileage
 - 3 the model of the car
 - 4 the weight of the car
- 135 Which set of data describes a situation that could be classified as qualitative?
- 1 the colors of the birds at the city zoo
 - 2 the shoe size of the zookeepers at the city zoo
 - 3 the heights of the giraffes at the city zoo
 - 4 the weights of the monkeys at the city zoo
- 136 An art studio has a list of information posted with each sculpture that is for sale. Each entry in the list could be classified as quantitative *except* for the
- 1 cost
 - 2 height
 - 3 artist
 - 4 weight
- 137 Which data can be classified as quantitative?
- 1 favorite stores at which you shop
 - 2 U.S. Representatives and their home states
 - 3 sales tax rate in each New York county
 - 4 opinion of a freshman on the color of Paul's shirt
- 138 Which set of data is qualitative?
- 1 laps swum in a race
 - 2 number of swimmers on the team
 - 3 swimmers' favorite swimsuit colors
 - 4 temperature in Fahrenheit of the water in a pool
- 139 In a class, which data can be classified as qualitative?
- 1 age of students
 - 2 weight of students
 - 3 shoe size of students
 - 4 hair color of students
- 140 For a class of students, which data set could be classified as qualitative?
- 1 political opinions
 - 2 heights
 - 3 weights
 - 4 ages

A.S.2: ANALYSIS OF DATA

- 141 Which situation should be analyzed using bivariate data?
- 1 Ms. Saleem keeps a list of the amount of time her daughter spends on her social studies homework.
 - 2 Mr. Benjamin tries to see if his students' shoe sizes are directly related to their heights.
 - 3 Mr. DeStefan records his customers' best video game scores during the summer.
 - 4 Mr. Chan keeps track of his daughter's algebra grades for the quarter.

142 Which data table represents univariate data?

1

Side Length of a Square	Area of Square
2	4
3	9
4	16
5	25

2

Hours Worked	Pay
20	\$160
25	\$200
30	\$240
35	\$280

3

Age Group	Frequency
20–29	9
30–39	7
40–49	10
50–59	4

4

People	Number of Fingers
2	20
3	30
4	40
5	50

143 Which table does *not* show bivariate data?

1

Height (inches)	Weight (pounds)
39	50
48	70
60	90

2

Gallons	Miles Driven
15	300
20	400
25	500

3

Quiz Average	Frequency
70	12
80	15
90	6

4

Speed (mph)	Distance (miles)
40	80
50	120
55	150

144 Which situation is an example of bivariate data?

- 1 the number of pizzas Tanya eats during her years in high school
- 2 the number of times Ezra puts air, in his bicycle tires during the summer
- 3 the number of home runs Elias hits per game and the number of hours he practices baseball
- 4 the number of hours Nellie studies for her mathematics tests during the first half of the school year

145 Which table shows bivariate data?

Age (yr)	Frequency
14	12
15	21
16	14
17	19
18	15

1

Type of Car	Average Gas Mileage (mpg)
van	25
SUV	23
luxury	26
compact	28
pickup	22

2

Time Spent Studying (hr)	Test Grade (%)
1	65
2	72
3	83
4	85
5	92

3

Day	Temperature (degrees F)
Monday	63
Tuesday	58
Wednesday	72
Thursday	74
Friday	78

4

146 Which situation is represented by bivariate data?

- 1 A student lists her algebra quiz grades for one month.
- 2 A wrestler records his weight before each match.
- 3 A musician writes down how many minutes she practices her instrument each day.
- 4 An ice cream vendor tracks the daily high temperature and how many ice cream bars he sells each day.

147 Which situation is an example of bivariate data?

- 1 shoe sizes of a tennis team
- 2 goals scored in soccer games
- 3 Calories consumed in one day
- 4 hours studying compared to test scores

A.S.3: ANALYSIS OF DATA

148 A school wants to add a coed soccer program. To determine student interest in the program, a survey will be taken. In order to get an unbiased sample, which group should the school survey?

- 1 every third student entering the building
- 2 every member of the varsity football team
- 3 every member in Ms. Zimmer's drama classes
- 4 every student having a second-period French class

149 A survey is being conducted to determine which types of television programs people watch. Which survey and location combination would likely contain the most bias?

- 1 surveying 10 people who work in a sporting goods store
- 2 surveying the first 25 people who enter a grocery store
- 3 randomly surveying 50 people during the day in a mall
- 4 randomly surveying 75 people during the day in a clothing store

150 Erica is conducting a survey about the proposed increase in the sports budget in the Hometown School District. Which survey method would likely contain the most bias?

- 1 Erica asks every third person entering the Hometown Grocery Store.
- 2 Erica asks every third person leaving the Hometown Shopping Mall this weekend.
- 3 Erica asks every fifth student entering Hometown High School on Monday morning.
- 4 Erica asks every fifth person leaving Saturday's Hometown High School football game.

- 151 Four hundred licensed drivers participated in the math club's survey on driving habits. The table below shows the number of drivers surveyed in each age group.

Ages of People in Survey on Driving Habits

Age Group	Number of Drivers
16–25	150
26–35	129
36–45	33
46–55	57
56–65	31

Which statement best describes a conclusion based on the data in the table?

- 1 It may be biased because no one younger than 16 was surveyed.
 - 2 It would be fair because many different age groups were surveyed.
 - 3 It would be fair because the survey was conducted by the math club students.
 - 4 It may be biased because the majority of drivers surveyed were in the younger age intervals.
- 152 A survey is being conducted to determine which school board candidate would best serve the Yonkers community. Which group, when randomly surveyed, would likely produce the most bias?
- 1 15 employees of the Yonkers school district
 - 2 25 people driving past Yonkers High School
 - 3 75 people who enter a Yonkers grocery store
 - 4 100 people who visit the local Yonkers shopping mall
- 153 A survey is being conducted to determine if a cable company should add another sports channel to their schedule. Which random survey would be the least biased?
- 1 surveying 30 men at a gym
 - 2 surveying 45 people at a mall
 - 3 surveying 50 fans at a football game
 - 4 surveying 20 members of a high school soccer team
- 154 A school newspaper will survey students about the quality of the school's lunch program. Which method will create the *least* biased results?
- 1 Twenty-five vegetarians are randomly surveyed.
 - 2 Twenty-five students are randomly chosen from each grade level.
 - 3 Students who dislike the school's lunch program are chosen to complete the survey.
 - 4 A booth is set up in the cafeteria for the students to voluntarily complete the survey.
- 155 Which statement regarding biased sampling is *false*?
- 1 Online sampling is biased because only the people who happen to visit the web site will take the survey.
 - 2 A radio call-in survey is biased because only people who feel strongly about the topic will respond.
 - 3 A survey handed to every third person leaving a library is biased because everyone leaving the library was not asked to participate.
 - 4 Asking for experts to take a survey is biased because they may have particular knowledge of the topic.
- 156 A local government is planning to increase the fee for use of a campsite. If a survey were taken, which group would be most biased in their *opposition* to the increase?
- 1 teachers
 - 2 soccer players
 - 3 postal workers
 - 4 campers

A.S.13: ANALYSIS OF DATA

- 157 Which relationship can best be described as causal?
- 1 height and intelligence
 - 2 shoe size and running speed
 - 3 number of correct answers on a test and test score
 - 4 number of students in a class and number of students with brown hair

Integrated Algebra Regents Exam Questions by Performance Indicator: Topic

www.jmap.org

- 158 Which situation does *not* describe a causal relationship?
- 1 The higher the volume on a radio, the louder the sound will be.
 - 2 The faster a student types a research paper, the more pages the paper will have.
 - 3 The shorter the distance driven, the less gasoline that will be used.
 - 4 The slower the pace of a runner, the longer it will take the runner to finish the race.
- 159 Which relationship can best be described as causal?
- 1 The alarm goes off and the sun rises.
 - 2 The car is moving slowly and the driver is singing.
 - 3 The snow is falling and the stores run out of snow shovels.
 - 4 The birds are chirping and the rain is coming down.

A.S.14: ANALYSIS OF DATA

- 160 Which situation describes a correlation that is *not* a causal relationship?
- 1 The rooster crows, and the Sun rises.
 - 2 The more miles driven, the more gasoline needed
 - 3 The more powerful the microwave, the faster the food cooks.
 - 4 The faster the pace of a runner, the quicker the runner finishes.
- 161 Which situation describes a correlation that is *not* a causal relationship?
- 1 the length of the edge of a cube and the volume of the cube
 - 2 the distance traveled and the time spent driving
 - 3 the age of a child and the number of siblings the child has
 - 4 the number of classes taught in a school and the number of teachers employed

- 162 Which phrase best describes the relationship between the number of miles driven and the amount of gasoline used?
- 1 causal, but not correlated
 - 2 correlated, but not causal
 - 3 both correlated and causal
 - 4 neither correlated nor causal
- 163 A study showed that a decrease in the cost of carrots led to an increase in the number of carrots sold. Which statement best describes this relationship?
- 1 positive correlation and a causal relationship
 - 2 negative correlation and a causal relationship
 - 3 positive correlation and not a causal relationship
 - 4 negative correlation and not a causal relationship
- 164 Which situation describes a correlation that is *not* a causal relationship?
- 1 the number of miles walked and the total Calories burned
 - 2 the population of a country and the census taken every ten years
 - 3 the number of hours a TV is on and the amount of electricity used
 - 4 the speed of a car and the number of hours it takes to travel a given distance

A.M.3: ERROR

- 165 The groundskeeper is replacing the turf on a football field. His measurements of the field are 130 yards by 60 yards. The actual measurements are 120 yards by 54 yards. Which expression represents the relative error in the measurement?
- 1 $\frac{(130)(60) - (120)(54)}{(120)(54)}$
 - 2 $\frac{(120)(54)}{(130)(60) - (120)(54)}$
 - 3 $\frac{(130)(60) - (120)(54)}{(130)(60)}$
 - 4 $\frac{(130)(60)}{(130)(60) - (120)(54)}$

Integrated Algebra Regents Exam Questions by Performance Indicator: Topic

www.jmap.org

- 166 Sophie measured a piece of paper to be 21.7 cm by 28.5 cm. The piece of paper is actually 21.6 cm by 28.4 cm. Determine the number of square centimeters in the area of the piece of paper using Sophie's measurements. Determine the number of square centimeters in the actual area of the piece of paper. Determine the relative error in calculating the area. Express your answer as a decimal to the *nearest thousandth*. Sophie does not think there is a significant amount of error. Do you agree or disagree? Justify your answer.
- 167 Ryan estimates the measurement of the volume of a popcorn container to be 282 cubic inches. The actual volume of the popcorn container is 289 cubic inches. What is the relative error of Ryan's measurement to the *nearest thousandth*?
- 1 0.024
 - 2 0.025
 - 3 0.096
 - 4 1.025
- 168 Sarah measures her rectangular bedroom window for a new shade. Her measurements are 36 inches by 42 inches. The actual measurements of the window are 36.5 inches and 42.5 inches. Using the measurements that Sarah took, determine the number of square inches in the area of the window. Determine the number of square inches in the actual area of the window. Determine the relative error in calculating the area. Express your answer as a decimal to the *nearest thousandth*.
- 169 To calculate the volume of a small wooden cube, Ezra measured an edge of the cube as 2 cm. The actual length of the edge of Ezra's cube is 2.1 cm. What is the relative error in his volume calculation to the *nearest hundredth*?
- 1 0.13
 - 2 0.14
 - 3 0.15
 - 4 0.16
- 170 Carrie bought new carpet for her living room. She calculated the area of the living room to be 174.2 square feet. The actual area was 149.6 square feet. What is the relative error of the area to the *nearest ten-thousandth*?
- 1 0.1412
 - 2 0.1644
 - 3 1.8588
 - 4 2.1644
- 171 Using his ruler, Howell measured the sides of a rectangular prism to be 5 cm by 8 cm by 4 cm. The actual measurements are 5.3 cm by 8.2 cm by 4.1 cm. Find Howell's relative error in calculating the volume of the prism, to the *nearest thousandth*.
- 172 Alexis calculates the surface area of a gift box as 600 square inches. The actual surface area of the gift box is 592 square inches. Find the relative error of Alexis' calculation expressed as a decimal to the *nearest thousandth*.
- 173 Corinne calculated the area of a paper plate to be 50.27 square inches. If the actual area of the plate is 55.42 square inches, what is the relative error in calculating the area, to the *nearest thousandth*?
- 1 0.092
 - 2 0.093
 - 3 0.102
 - 4 0.103
- 174 An oil company distributes oil in a metal can shaped like a cylinder that has an actual radius of 5.1 cm and a height of 15.1 cm. A worker incorrectly measured the radius as 5 cm and the height as 15 cm. Determine the relative error in calculating the surface area, to the *nearest thousandth*.

Integrated Algebra Regents Exam Questions by Performance Indicator: Topic

www.jmap.org

- 175 The dimensions of a rectangle are measured to be 12.2 inches by 11.8 inches. The actual dimensions are 12.3 inches by 11.9 inches. What is the relative error, to the *nearest ten-thousandth*, in calculating the area of the rectangle?
- 1 0.0168
 - 2 0.0167
 - 3 0.0165
 - 4 0.0164
- 176 Jack wants to replace the flooring in his rectangular kitchen. He calculates the area of the floor to be 12.8 square meters. The actual area of the floor is 13.5 square meters. What is the relative error in calculating the area of the floor, to the *nearest thousandth*?
- 1 0.051
 - 2 0.052
 - 3 0.054
 - 4 0.055
- 177 The actual dimensions of a rectangle are 2.6 cm by 6.9 cm. Andy measures the sides as 2.5 cm by 6.8 cm. In calculating the area, what is the relative error, to the *nearest thousandth*?
- 1 0.055
 - 2 0.052
 - 3 0.022
 - 4 0.021
- 178 Students calculated the area of a playing field to be 8,100 square feet. The actual area of the field is 7,678.5 square feet. Find the relative error in the area, to the *nearest thousandth*.
- 179 Ashley measured the dimensions of a rectangular prism to be 6 cm by 10 cm by 1.5 cm. The actual dimensions are 5.9 cm by 10.3 cm by 1.7 cm. Determine the relative error, to the *nearest thousandth*, in calculating the volume of the prism.
- 180 Wendy measures the floor in her rectangular bedroom for new carpeting. Her measurements are 24 feet by 14 feet. The actual measurements are 24.2 feet by 14.1 feet. Determine the relative error in calculating the area of her bedroom. Express your answer as a decimal to the *nearest thousandth*.
- 181 Janis measures the dimensions of the floor in her rectangular classroom for a rug. Her measurements are 10.50 feet by 12.25 feet. The actual measurements of the floor are 10.75 feet by 12.50 feet. Determine the relative error in calculating the area, to the *nearest thousandth*.
- 182 Terry estimated the length of the edge of a cube to be 5 cm. The actual length of the side is 5.2 cm. Find the relative error of the surface area of the cube, to the *nearest thousandth*.
- 183 A storage container in the form of a rectangular prism is measured to be 12 inches by 8 inches by 4 inches. Its actual measurements are 11.75 inches by 7.75 inches by 4 inches. Find the relative error in calculating the volume of the container, to the *nearest thousandth*.
- 184 The actual side of a square tile is 4 inches. The manufacturers allow a relative error of 0.025 in the area of a tile. Two machines are used to cut the tiles. Machine A produces a square tile with a length of 3.97 inches. Machine B produces a square tile with a length of 4.12 inches. Determine which machine produces a tile whose area falls within the allowed relative error.
- 185 Linda measures her rectangular bedroom window for a new shade. The measurements she made are 36 inches by 42 inches. The actual measurements of the window are 36.5 inches and 42.5 inches. Determine the relative error in calculating the area. Express your answer as a decimal to the *nearest thousandth*.

PROBABILITY

A.S.19: SAMPLE SPACE

- 186 Mr. Laub has three children: two girls (Sue and Karen) and one boy (David). After each meal, one child is chosen at random to wash dishes. If the same child can be chosen for both lunch and dinner, construct a tree diagram or list a sample space of all the possible outcomes of who will wash dishes after lunch and dinner on Saturday. Determine the probability that one boy and one girl will wash dishes after lunch and dinner on Saturday.

- 187 A restaurant sells kids' meals consisting of one main course, one side dish, and one drink, as shown in the table below.

Kids' Meal Choices

Main Course	Side Dish	Drink
hamburger	French fries	milk
chicken nuggets	applesauce	juice
turkey sandwich		soda

Draw a tree diagram or list the sample space showing all possible kids' meals. How many different kids' meals can a person order? Jose does not drink juice. Determine the number of different kids' meals that do *not* include juice. Jose's sister will eat *only* chicken nuggets for her main course. Determine the number of different kids' meals that include chicken nuggets.

- 188 Clayton has three fair coins. Find the probability that he gets two tails and one head when he flips the three coins.

- 189 An outfit Jennifer wears to school consists of a top, a bottom, and shoes. Possible choices are listed below.

Tops: T-shirt, blouse, sweater

Bottoms: jeans, skirt, capris

Shoes: flip-flops, sneakers

List the sample space or draw a tree diagram to represent all possible outfits consisting of one type of top, one type of bottom, and one pair of shoes. Determine how many different outfits contain jeans and flip-flops. Determine how many different outfits do *not* include a sweater.

- 190 A sandwich consists of one type of bread, one type of meat, and one type of cheese. The possible choices are listed below.

Bread: white, rye

Meat: ham, turkey, beef

Cheese: American, Swiss

Draw a tree diagram or list a sample space of all the possible different sandwiches consisting of one type of bread, one type of meat, and one type of cheese. Determine the number of sandwiches that will *not* include turkey. Determine the number of sandwiches that will include rye bread and Swiss cheese.

- 191 A company is running a contest and offering a first, second, and third prize. First prize is a choice of a car or \$15,000 cash. Second prize is a choice of a motorbike, a trip to New York City, or \$2,000 cash. Third prize is a choice of a television or \$500 cash. If each prize is equally likely to be selected, list the sample space or draw a tree diagram of *all* possible different outcomes of first, second, and third prizes. Determine the number of ways that *all* three prizes selected could be cash. Determine the number of ways that *none* of the three prizes selected could be cash.

- 192 In a game, a player must spin each spinner shown in the diagram below once.



Spinner 1

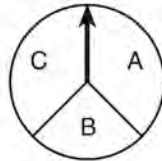

Spinner 2

Draw a tree diagram or list a sample space showing all possible outcomes. Determine the number of outcomes that consist of a prime number and a letter in the word "CAT."

- 193 A cube, with faces numbered 1 to 6, is rolled, and a penny is tossed at the same time. How many elements in the sample space consist of an even number and a tail?

- 1 12
- 2 2
- 3 3
- 4 4

- 194 Doug has four baseball caps: one tan, one blue, one red, and one green. He also has three jackets: one blue, one red, and one white. Draw a tree diagram or list a sample space to show all possible outfits consisting of one baseball cap and one jacket. Find the number of Doug's outfits that consist of a cap and a jacket that are different colors. On Spirit Day, Doug wants to wear either green or white, his school's colors. Find the number of his outfits from which he can choose.

- 195 Clayton is performing some probability experiments consisting of flipping three fair coins. What is the probability that when Clayton flips the three coins, he gets two tails and one head?

- 196 A sandwich consists of one type of meat, one type of condiment, and one type of cheese. The possible choices are listed below:

Meat: beef, chicken, turkey

Condiment: ketchup, mustard, mayonnaise

Cheese: American, cheddar, provolone, mozzarella

In the sample space of all the possible different sandwiches consisting of one type of meat, one type of condiment, and one type of cheese, how many sandwiches do *not* include provolone cheese?

- 1 27
- 2 9
- 3 3
- 4 36

A.S.21: EXPERIMENTAL PROBABILITY

- 197 Students in Ms. Nazzeer's mathematics class tossed a six-sided number cube whose faces are numbered 1 to 6. The results are recorded in the table below.

Result	Frequency
1	3
2	6
3	4
4	6
5	4
6	7

Based on these data, what is the empirical probability of tossing a 4?

- 1 $\frac{8}{30}$
- 2 $\frac{6}{30}$
- 3 $\frac{5}{30}$
- 4 $\frac{1}{30}$

- 198 Three high school juniors, Reese, Matthew, and Chris, are running for student council president. A survey is taken a week before the election asking 40 students which candidate they will vote for in the election. The results are shown in the table below.

Candidate's Name	Number of Students Supporting Candidate
Reese	15
Matthew	13
Chris	12

Based on the table, what is the probability that a student will vote for Reese?

- 1 $\frac{1}{3}$
- 2 $\frac{3}{5}$
- 3 $\frac{3}{8}$
- 4 $\frac{5}{8}$

- 199 A spinner that is equally divided into eight numbered sectors is spun 20 times. The table below shows the number of times the arrow landed in each numbered sector.

Spinner Sector	Number of Times
1	2
2	3
3	2
4	3
5	4
6	2
7	3
8	1

Based on the table, what is the empirical probability that the spinner will land on a prime number on the next spin?

- 1 $\frac{9}{20}$
- 2 $\frac{11}{20}$
- 3 $\frac{12}{20}$
- 4 $\frac{14}{20}$

- 200 Casey purchased a pack of assorted flower seeds and planted them in her garden. When the first 25 flowers bloomed, 11 were white, 5 were red, 3 were blue, and the rest were yellow. Find the empirical probability that a flower that blooms will be yellow.

- 201 Two cubes with sides numbered 1 through 6 were rolled 20 times. Their sums are recorded in the table below.

4	9	8	9	2
9	4	6	12	10
8	7	9	11	10
8	7	9	3	5

What is the empirical probability of rolling a sum of 9?

- 1 $\frac{4}{20}$
 - 2 $\frac{5}{20}$
 - 3 $\frac{4}{36}$
 - 4 $\frac{5}{36}$
- 202 Three students each rolled a wooden cube with faces painted red, white, and blue. The color of the top face is recorded each time the cube is rolled. The table below shows the results.

Student	Number of Rolls	Red	White	Blue
1	30	11	7	12
2	50	19	11	20
3	20	8	4	8

If a fourth student rolled the cube 75 times, based on these experimental data, approximately how many times can the cube be expected to land with blue on top?

- 1 25
- 2 30
- 3 35
- 4 40

- 203 There are 4 students running for Student Government President. A survey was taken asking 100 students which candidate they would vote for in the election. The results are shown in the table below:

Candidate's Name	Number of Supporters
Ashley	30
Britney	28
Lyshon	14
Walker	28

Based on the table, what is the probability that a student chosen at random will vote for Lyshon?

- 1 $\frac{3}{10}$
- 2 $\frac{7}{25}$
- 3 $\frac{7}{50}$
- 4 $\frac{43}{50}$

A.S.20: THEORETICAL PROBABILITY

- 204 A bag contains eight green marbles, five white marbles, and two red marbles. What is the probability of drawing a red marble from the bag?
- 1 $\frac{1}{15}$
 - 2 $\frac{2}{15}$
 - 3 $\frac{2}{13}$
 - 4 $\frac{13}{15}$

A.S.22: THEORETICAL PROBABILITY

- 205 The faces of a cube are numbered from 1 to 6. If the cube is rolled once, which outcome is *least* likely to occur?
- 1 rolling an odd number
 - 2 rolling an even number
 - 3 rolling a number less than 6
 - 4 rolling a number greater than 4
- 206 Jon is buying tickets for himself for two concerts. For the jazz concert, 4 tickets are available in the front row, and 32 tickets are available in the other rows. For the orchestra concert, 3 tickets are available in the front row, and 23 tickets are available in the other rows. Jon is randomly assigned one ticket for each concert. Determine the concert for which he is more likely to get a front-row ticket. Justify your answer.
- 207 Each of the hats shown below has colored marbles placed inside. Hat A contains five green marbles and four red marbles. Hat B contains six blue marbles and five red marbles. Hat C contains five green marbles and five blue marbles.



If a student were to randomly pick one marble from each of these three hats, determine from which hat the student would most likely pick a green marble. Justify your answer. Determine the fewest number of marbles, if any, and the color of these marbles that could be added to *each* hat so that the probability of picking a green marble will be one-half in each of the three hats.

- 208 Maria has a set of 10 index cards labeled with the digits 0 through 9. She puts them in a bag and selects one at random. The outcome that is most likely to occur is selecting
- 1 an odd number
 - 2 a prime number
 - 3 a number that is at most 5
 - 4 a number that is divisible by 3
- 209 Three storage bins contain colored blocks. Bin 1 contains 15 red and 14 blue blocks. Bin 2 contains 16 white and 15 blue blocks. Bin 3 contains 15 red and 15 white blocks. All of the blocks from the three bins are placed into one box. If one block is randomly selected from the box, which color block would most likely be picked? Justify your answer.
- 210 A cube with faces numbered 1 through 6 is rolled 75 times, and the results are given in the table below.

Number	Frequency
1	7
2	22
3	14
4	6
5	20
6	6

Based on these results, which statement is true?

- 1 $P(\text{odd}) < P(\text{even})$
 - 2 $P(3 \text{ or less}) < P(\text{odd})$
 - 3 $P(\text{even}) < P(2 \text{ or } 4)$
 - 4 $P(2 \text{ or } 4) < P(3 \text{ or less})$
- 211 Which event is certain to happen?
- 1 Everyone walking into a room will have red hair.
 - 2 All babies born in June will be males.
 - 3 The Yankees baseball team will win the World Series.
 - 4 The Sun will rise in the east.

A.S.23: THEORETICAL PROBABILITY

- 212 Throughout history, many people have contributed to the development of mathematics. These mathematicians include Pythagoras, Euclid, Hypatia, Euler, Einstein, Agnesi, Fibonacci, and Pascal. What is the probability that a mathematician's name selected at random from those listed will start with either the letter *E* or the letter *A*?
- 1 $\frac{2}{8}$
 - 2 $\frac{3}{8}$
 - 3 $\frac{4}{8}$
 - 4 $\frac{6}{8}$
- 213 The faces of a cube are numbered from 1 to 6. If the cube is tossed once, what is the probability that a prime number or a number divisible by 2 is obtained?
- 1 $\frac{6}{6}$
 - 2 $\frac{5}{6}$
 - 3 $\frac{4}{6}$
 - 4 $\frac{1}{6}$
- 214 The probability that it will snow on Sunday is $\frac{3}{5}$. The probability that it will snow on both Sunday and Monday is $\frac{3}{10}$. What is the probability that it will snow on Monday, if it snowed on Sunday?
- 1 $\frac{9}{50}$
 - 2 2
 - 3 $\frac{1}{2}$
 - 4 $\frac{9}{10}$
- 215 Vince buys a box of candy that consists of six chocolate pieces, four fruit-flavored pieces, and two mint pieces. He selects three pieces of candy at random, without replacement. Calculate the probability that the first piece selected will be fruit flavored and the other two will be mint. Calculate the probability that all three pieces selected will be the same type of candy.
- 216 Three fair coins are tossed. What is the probability that two heads and one tail appear?
- 1 $\frac{1}{8}$
 - 2 $\frac{3}{8}$
 - 3 $\frac{3}{6}$
 - 4 $\frac{2}{3}$
- 217 The probability it will rain tomorrow is $\frac{1}{2}$. The probability that our team will win tomorrow's basketball game is $\frac{3}{5}$. Which expression represents the probability that it will rain and that our team will *not* win the game?
- 1 $\frac{1}{2} + \frac{3}{5}$
 - 2 $\frac{1}{2} + \frac{2}{5}$
 - 3 $\frac{1}{2} \times \frac{3}{5}$
 - 4 $\frac{1}{2} \times \frac{2}{5}$
- 218 A jar contains five red marbles and three green marbles. A marble is drawn at random and not replaced. A second marble is then drawn from the jar. Find the probability that the first marble is red and the second marble is green. Find the probability that both marbles are red. Find the probability that both marbles are the same color.

219 A bottle contains 12 red marbles and 8 blue marbles. A marble is chosen at random and not replaced. Then, a second marble is chosen at random. Determine the probability that the two marbles are *not* the same color. Determine the probability that *at least* one of the marbles is red.

220 There are six apples, five oranges, and one pear in John's basket. His friend takes three pieces of fruit at random without replacement. Determine the probability that *all three* fruits taken are apples.

221 The probability that a student owns a dog is $\frac{1}{3}$. The probability that the same student owns a dog and a cat is $\frac{2}{15}$. Determine the probability that the student owns a cat.

A.S.20: GEOMETRIC PROBABILITY

222 The spinner below is divided into eight equal regions and is spun once. What is the probability of *not* getting red?

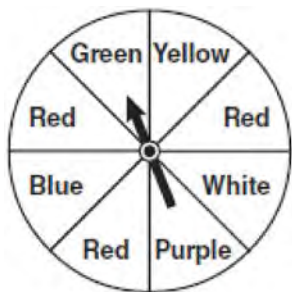

- 1 $\frac{3}{5}$
- 2 $\frac{3}{8}$
- 3 $\frac{5}{8}$
- 4 $\frac{7}{8}$

223 The square dart board shown below has a side that measures 40 inches. The shaded portion in the center is a square whose side is 15 inches. A dart thrown at the board is equally likely to land on any point on the dartboard.

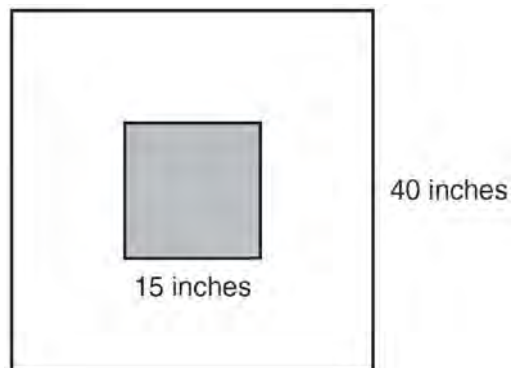

Find the probability that a dart hitting the board will *not* land in the shaded area.

- 224 The bull's-eye of a dartboard has a radius of 2 inches and the entire board has a radius of 9 inches, as shown in the diagram below.

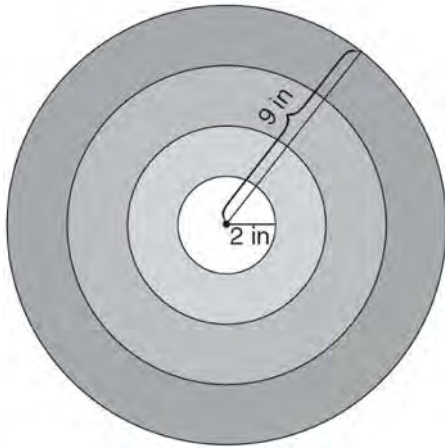

If a dart is thrown and hits the board, what is the probability that the dart will land in the bull's-eye?

- 1 $\frac{2}{9}$
- 2 $\frac{7}{9}$
- 3 $\frac{4}{81}$
- 4 $\frac{49}{81}$

A.S.22: GEOMETRIC PROBABILITY

- 225 A spinner is divided into eight equal regions as shown in the diagram below.

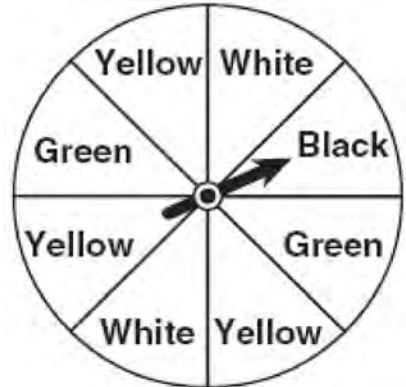

Which event is most likely to occur in one spin?

- 1 The arrow will land in a green or white area.
- 2 The arrow will land in a green or black area.
- 3 The arrow will land in a yellow or black area.
- 4 The arrow will land in a yellow or green area.

- 226 The spinner shown in the diagram below is divided into six equal sections.

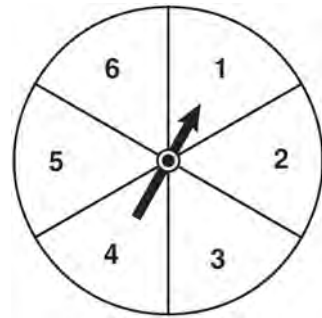

Which outcome is *least* likely to occur on a single spin?

- 1 an odd number
- 2 a prime number
- 3 a perfect square
- 4 a number divisible by 2

A.S.23: GEOMETRIC PROBABILITY

- 227 Brianna is using the two spinners shown below to play her new board game. She spins the arrow on each spinner once. Brianna uses the first spinner to determine how many spaces to move. She uses the second spinner to determine whether her move from the first spinner will be forward or backward.

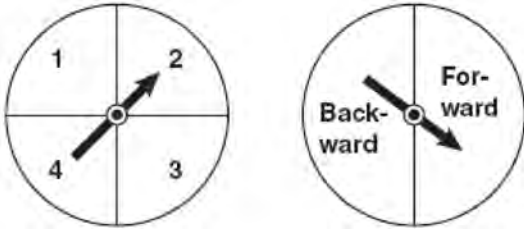

Find the probability that Brianna will move *fewer than four spaces and backward*.

- 228 Keisha is playing a game using a wheel divided into eight equal sectors, as shown in the diagram below. Each time the spinner lands on orange, she will win a prize.

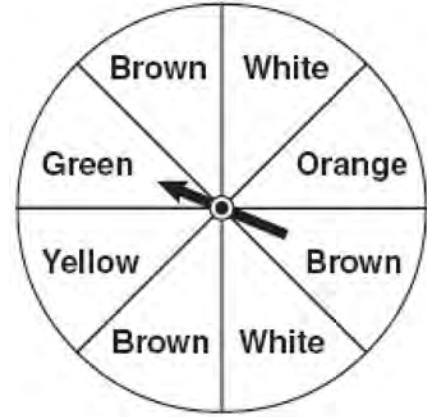

If Keisha spins this wheel twice, what is the probability she will win a prize on *both* spins?

- 1 $\frac{1}{64}$
- 2 $\frac{1}{56}$
- 3 $\frac{1}{16}$
- 4 $\frac{1}{4}$

A.S.18: CONDITIONAL PROBABILITY

- 229 Some books are laid on a desk. Two are English, three are mathematics, one is French, and four are social studies. Theresa selects an English book and Isabelle then selects a social studies book. Both girls take their selections to the library to read. If Truman then selects a book at random, what is the probability that he selects an English book?

230 A bag contains five green gumdrops and six red gumdrops. If Kim pulls a green gumdrop out of the bag and eats it, what is the probability that the next gumdrop she pulls out will be red?

- 1 $\frac{5}{11}$
- 2 $\frac{5}{10}$
- 3 $\frac{6}{11}$
- 4 $\frac{6}{10}$

231 Gabriella has 20 quarters, 15 dimes, 7 nickels, and 8 pennies in a jar. After taking 6 quarters out of the jar, what will be the probability of Gabriella randomly selecting a quarter from the coins left in the jar?

- 1 $\frac{14}{44}$
- 2 $\frac{30}{44}$
- 3 $\frac{14}{50}$
- 4 $\frac{20}{50}$

A.N.7: MULTIPLICATION COUNTING PRINCIPLE

232 The local ice cream stand offers three flavors of soft-serve ice cream: vanilla, chocolate, and strawberry; two types of cone: sugar and wafer; and three toppings: sprinkles, nuts, and cookie crumbs. If Dawn does not order vanilla ice cream, how many different choices can she make that have one flavor of ice cream, one type of cone, and one topping?

- 1 7
- 2 8
- 3 12
- 4 18

233 How many different sandwiches consisting of one type of cheese, one condiment, and one bread choice can be prepared from five types of cheese, two condiments, and three bread choices?

- 1 10
- 2 13
- 3 15
- 4 30

234 The menu for the high school cafeteria is shown below.

Main Course	Vegetable	Dessert	Beverage
veggie burger	corn	gelatin	milk
pizza	green beans	fruit salad	juice
tuna sandwich	carrots	yogurt	bottled water
frankfurter		cookie	
chicken tenders		ice cream cup	

Determine the number of possible meals consisting of a main course, a vegetable, a dessert, and a beverage that can be selected from the menu. Determine how many of these meals will include chicken tenders. If a student chooses pizza, corn or carrots, a dessert, and a beverage from the menu, determine the number of possible meals that can be selected.

235 A school offers three classes of math and two classes of science, all of which meet at different times. What is the total number of ways a student can take a math class and a science class?

- 1 5
- 2 6
- 3 8
- 4 9

A.N.8: PERMUTATIONS

- 236 The bowling team at Lincoln High School must choose a president, vice president, and secretary. If the team has 10 members, which expression could be used to determine the number of ways the officers could be chosen?
- 1 ${}_3P_{10}$
 - 2 ${}_7P_3$
 - 3 ${}_{10}P_3$
 - 4 ${}_{10}P_7$
- 237 John is going to line up his four golf trophies on a shelf in his bedroom. How many different possible arrangements can he make?
- 1 24
 - 2 16
 - 3 10
 - 4 4
- 238 Determine how many three-letter arrangements are possible with the letters *A, N, G, L,* and *E* if no letter may be repeated.
- 239 A password consists of three digits, 0 through 9, followed by three letters from an alphabet having 26 letters. If repetition of digits is allowed, but repetition of letters is not allowed, determine the number of different passwords that can be made. If repetition is not allowed for digits or letters, determine how many fewer different passwords can be made.
- 240 How many different three-letter arrangements can be formed using the letters in the word *ABSOLUTE* if each letter is used only once?
- 1 56
 - 2 112
 - 3 168
 - 4 336
- 241 How many different four-letter arrangements are possible with the letters *G, A, R, D, E, N* if each letter may be used only once?
- 1 15
 - 2 24
 - 3 360
 - 4 720
- 242 How many different ways can five books be arranged on a shelf?
- 1 5
 - 2 15
 - 3 25
 - 4 120
- 243 A large company must chose between two types of passwords to log on to a computer. The first type is a four-letter password using any of the 26 letters of the alphabet, without repetition of letters. The second type is a six-digit password using the digits 0 through 9, with repetition of digits allowed. Determine the number of possible four-letter passwords. Determine the number of possible six-digit passwords. The company has 500,000 employees and needs a different password for each employee. State which type of password the company should choose. Explain your answer.
- 244 There are 18 students in a class. Each day, the teacher randomly selects three students to assist in a game: a leader, a recorder, and a timekeeper. In how many possible ways can the jobs be assigned?
- 1 306
 - 2 816
 - 3 4896
 - 4 5832
- 245 How many different seven-letter arrangements of the letters in the word *HEXAGON* can be made if each letter is used only once?
- 1 28
 - 2 49
 - 3 720
 - 4 5040

Integrated Algebra Regents Exam Questions by Performance Indicator: Topic

EXPRESSIONS AND EQUATIONS

A.A.1: EXPRESSIONS

- 246 Mr. Turner bought x boxes of pencils. Each box holds 25 pencils. He left 3 boxes of pencils at home and took the rest to school. Which expression represents the total number of pencils he took to school?
- 1 $22x$
 - 2 $25x - 3$
 - 3 $25 - 3x$
 - 4 $25x - 75$
- 247 The length of a rectangular room is 7 less than three times the width, w , of the room. Which expression represents the area of the room?
- 1 $3w - 4$
 - 2 $3w - 7$
 - 3 $3w^2 - 4w$
 - 4 $3w^2 - 7w$
- 248 Marie currently has a collection of 58 stamps. If she buys s stamps each week for w weeks, which expression represents the total number of stamps she will have?
- 1 $58sw$
 - 2 $58 + sw$
 - 3 $58s + w$
 - 4 $58 + s + w$
- 249 What is the perimeter of a regular pentagon with a side whose length is $x + 4$?
- 1 $x^2 + 16$
 - 2 $4x + 16$
 - 3 $5x + 4$
 - 4 $5x + 20$
- 250 Tim ate four more cookies than Alice. Bob ate twice as many cookies as Tim. If x represents the number of cookies Alice ate, which expression represents the number of cookies Bob ate?
- 1 $2 + (x + 4)$
 - 2 $2x + 4$
 - 3 $2(x + 4)$
 - 4 $4(x + 2)$
- 251 Which algebraic expression represents 15 less than x divided by 9?
- 1 $\frac{x}{9} - 15$
 - 2 $9x - 15$
 - 3 $15 - \frac{x}{9}$
 - 4 $15 - 9x$
- 252 Timmy bought a skateboard and two helmets for a total of d dollars. If each helmet cost h dollars, the cost of the skateboard could be represented by
- 1 $2dh$
 - 2 $\frac{dh}{2}$
 - 3 $d - 2h$
 - 4 $d - \frac{h}{2}$
- 253 Marcy determined that her father's age is four less than three times her age. If x represents Marcy's age, which expression represents her father's age?
- 1 $3x - 4$
 - 2 $3(x - 4)$
 - 3 $4x - 3$
 - 4 $4 - 3x$
- 254 A correct translation of "six less than twice the value of x " is
- 1 $2x < 6$
 - 2 $2x - 6$
 - 3 $6 < 2x$
 - 4 $6 - 2x$

Integrated Algebra Regents Exam Questions by Performance Indicator: Topic

www.jmap.org

- 255 If Angelina's weekly allowance is d dollars, which expression represents her allowance, in dollars, for x weeks?
- 1 dx
 - 2 $7dx$
 - 3 $x + 7d$
 - 4 $\frac{d}{x}$
- 256 Which expression represents "5 less than twice x "?
- 1 $2x - 5$
 - 2 $5 - 2x$
 - 3 $2(5 - x)$
 - 4 $2(x - 5)$
- 257 Which expression represents the number of hours in w weeks and d days?
- 1 $7w + 12d$
 - 2 $84w + 24d$
 - 3 $168w + 24d$
 - 4 $168w + 60d$
- 258 Marie currently has a collection of 58 stamps. If she buys s stamps each week for w weeks, which expression represents the total number of stamps she will have?
- 1 $58sw$
 - 2 $58 + sw$
 - 3 $58s + w$
 - 4 $58 + s + w$
- 259 Julie has three children whose ages are consecutive odd integers. If x represents the youngest child's age, which expression represents the sum of her children's ages?
- 1 $3x + 3$
 - 2 $3x + 4$
 - 3 $3x + 5$
 - 4 $3x + 6$
- 260 Jose wants to ride his bike a total of 50 miles this weekend. If he rides m miles on Saturday, which expression represents the number of miles he must ride on Sunday?
- 1 $m - 50$
 - 2 $m + 50$
 - 3 $50 - m$
 - 4 $50m$
- 261 Owino gets paid \$280 per week plus 5% commission on all sales for selling electronic equipment. If he sells n dollars worth of electronic equipment in one week, which algebraic expression represents the amount of money he will earn that week?
- 1 $280n + 5$
 - 2 $280n + 0.05$
 - 3 $280 + 0.05n$
 - 4 $280 + 5n$

A.A.2: EXPRESSIONS

- 262 Which verbal expression represents $2(n - 6)$?
- 1 two times n minus six
 - 2 two times six minus n
 - 3 two times the quantity n less than six
 - 4 two times the quantity six less than n
- 263 Which verbal expression is represented by $\frac{1}{2}(n - 3)$?
- 1 one-half n decreased by 3
 - 2 one-half n subtracted from 3
 - 3 the difference of one-half n and 3
 - 4 one-half the difference of n and 3
- 264 Which verbal expression can be represented by $2(x - 5)$?
- 1 5 less than 2 times x
 - 2 2 multiplied by x less than 5
 - 3 twice the difference of x and 5
 - 4 the product of 2 and x , decreased by 5

- 265 Which verbal expression is represented by $2(x + 4)$?
- 1 twice the sum of a number and four
 - 2 the sum of two times a number and four
 - 3 two times the difference of a number and four
 - 4 twice the product of a number and four

A.A.3: EXPRESSIONS

- 266 Chad complained to his friend that he had five equations to solve for homework. Are all of the homework problems equations? Justify your answer.

Math Homework

1. $3x^2 \cdot 2x^4$
2. $5 - 2x = 3x$
3. $3(2x + 7)$
4. $7x^2 + 2x - 3x^2 - 9$
5. $\frac{2}{3} = \frac{x+2}{6}$

Name Chad

- 267 An example of an algebraic expression is
- 1 $\frac{2x+3}{7} = \frac{13}{x}$
 - 2 $(2x + 1)(x - 7)$
 - 3 $4x - 1 = 4$
 - 4 $x = 2$
- 268 An example of an algebraic expression is
- 1 $x + 2$
 - 2 $y = x + 2$
 - 3 $y < x + 2$
 - 4 $y = x^2 + 2x$

- 269 An example of an algebraic expression is
- 1 $y = mx + b$
 - 2 $3x + 4y - 7$
 - 3 $2x + 3y \leq 18$
 - 4 $(x + y)(x - y) = 25$

- 270 Mr. Stanton asked his students to write an algebraic expression on a piece of paper. He chose four students to go to the board and write their expression.

Robert wrote: $4(2x + 5) \geq 17$

Meredith wrote: $3y - 7 + 11z$

Steven wrote: $9w + 2 = 20$

Cynthia wrote: $8 + 10 - 4 = 14$

Which student wrote an algebraic expression?

- 1 Robert
 - 2 Meredith
 - 3 Steven
 - 4 Cynthia
- 271 An example of an equation is
- 1 $2x^2 - 4x + 12$
 - 2 $|x - 6|$
 - 3 $4(x + 6)(x - 2)$
 - 4 $2x = x^2 + 3$
- 272 An example of an algebraic equation is
- 1 $r^2 + 1$
 - 2 $2a + (n - 1)d$
 - 3 $5x = 7$
 - 4 $-25\pi + 100$
- 273 Four students are playing a math game at home. One of the math game questions asked them to write an algebraic equation.
- Brandon wrote: $3(5x - 0)$
- William wrote: $7 < 2(6 + x)$
- Alice wrote: $15x$
- Kayla wrote: $11 = 2x + 3$
- Which student wrote an algebraic equation?
- 1 Brandon
 - 2 William
 - 3 Alice
 - 4 Kayla

A.A.22: SOLVING EQUATIONS

274 Solve for g : $3 + 2g = 5g - 9$

275 Which value of p is the solution of $5p - 1 = 2p + 20$?

1 $\frac{19}{7}$

2 $\frac{19}{3}$

3 3

4 7

276 Debbie solved the linear equation $3(x + 4) - 2 = 16$ as follows:

[Line 1] $3(x + 4) - 2 = 16$

[Line 2] $3(x + 4) = 18$

[Line 3] $3x + 4 = 18$

[Line 4] $3x = 14$

[Line 5] $x = 4\frac{2}{3}$

She made an error between lines

1 1 and 2

2 2 and 3

3 3 and 4

4 4 and 5

277 What is the value of x in the equation

$2(x - 4) = 4(2x + 1)$?

1 -2

2 2

3 $-\frac{1}{2}$

4 $\frac{1}{2}$

278 Solve algebraically for x :

$3(x + 1) - 5x = 12 - (6x - 7)$

279 The solution of the equation $5 - 2x = -4x - 7$ is

1 1

2 2

3 -2

4 -6

280 Which value of x is the solution of the equation $2(x - 4) + 7 = 3$?

1 1

2 2

3 6

4 0

A.A.25: SOLVING EQUATIONS WITH FRACTIONAL EXPRESSIONS

281 Which value of x is the solution of

$\frac{2x}{5} + \frac{1}{3} = \frac{7x - 2}{15}$?

1 $\frac{3}{5}$

2 $\frac{31}{26}$

3 3

4 7

282 Which value of x is the solution of the equation

$\frac{2x}{3} + \frac{x}{6} = 5$?

1 6

2 10

3 15

4 30

283 Solve for x : $\frac{3}{5}(x + 2) = x - 4$

1 8

2 13

3 15

4 23

284 Which value of x is the solution of $\frac{x}{3} + \frac{x+1}{2} = x$?

- 1 1
- 2 -1
- 3 3
- 4 -3

285 Which value of x is the solution of the equation

$$\frac{2}{3}x + \frac{1}{2} = \frac{5}{6}?$$

- 1 $\frac{1}{2}$
- 2 2
- 3 $\frac{2}{3}$
- 4 $\frac{3}{2}$

286 Solve for m : $\frac{m}{5} + \frac{3(m-1)}{2} = 2(m-3)$

287 Which value of x is the solution of the equation

$$\frac{1}{7} + \frac{2x}{3} = \frac{15x-3}{21}?$$

- 1 6
- 2 0
- 3 $\frac{4}{13}$
- 4 $\frac{6}{29}$

A.A.25: SOLVING EQUATIONS WITH DECIMALS

288 The value of y in the equation

$$0.06y + 200 = 0.03y + 350$$
 is

- 1 500
- 2 1,666. $\bar{6}$
- 3 5,000
- 4 18,333. $\bar{3}$

289 What is the value of n in the equation $0.2(n-6) = 2.8$?

- 1 8
- 2 2
- 3 20
- 4 44

A.A.4: MODELING EQUATIONS

290 If h represents a number, which equation is a correct translation of "Sixty more than 9 times a number is 375"?

- 1 $9h = 375$
- 2 $9h + 60 = 375$
- 3 $9h - 60 = 375$
- 4 $60h + 9 = 375$

291 The width of a rectangle is 4 less than half the length. If ℓ represents the length, which equation could be used to find the width, w ?

- 1 $w = \frac{1}{2}(4 - \ell)$
- 2 $w = \frac{1}{2}(\ell - 4)$
- 3 $w = \frac{1}{2}\ell - 4$
- 4 $w = 4 - \frac{1}{2}\ell$

292 Three times the sum of a number and four is equal to five times the number, decreased by two. If x represents the number, which equation is a correct translation of the statement?

- 1 $3(x+4) = 5x - 2$
- 2 $3(x+4) = 5(x-2)$
- 3 $3x + 4 = 5x - 2$
- 4 $3x + 4 = 5(x-2)$

293 The product of a number and 3, increased by 5, is 7 less than twice the number. Which equation can be used to find this number, n ?

- 1 $3n + 5 = 2n - 7$
- 2 $3n + 5 = 7 - 2n$
- 3 $3(n + 5) = 2n - 7$
- 4 $3(n + 5) = 7 - 2n$

A.A.5: MODELING EQUATIONS

294 The length of a rectangular window is 5 feet more than its width, w . The area of the window is 36 square feet. Which equation could be used to find the dimensions of the window?

1 $w^2 + 5w + 36 = 0$

2 $w^2 - 5w - 36 = 0$

3 $w^2 - 5w + 36 = 0$

4 $w^2 + 5w - 36 = 0$

295 Rhonda has \$1.35 in nickels and dimes in her pocket. If she has six more dimes than nickels, which equation can be used to determine x , the number of nickels she has?

1 $0.05(x + 6) + 0.10x = 1.35$

2 $0.05x + 0.10(x + 6) = 1.35$

3 $0.05 + 0.10(6x) = 1.35$

4 $0.15(x + 6) = 1.35$

296 The width of a rectangle is 3 less than twice the length, x . If the area of the rectangle is 43 square feet, which equation can be used to find the length, in feet?

1 $2x(x - 3) = 43$

2 $x(3 - 2x) = 43$

3 $2x + 2(2x - 3) = 43$

4 $x(2x - 3) = 43$

297 If n is an odd integer, which equation can be used to find three consecutive odd integers whose sum is -3 ?

1 $n + (n + 1) + (n + 3) = -3$

2 $n + (n + 1) + (n + 2) = -3$

3 $n + (n + 2) + (n + 4) = -3$

4 $n + (n + 2) + (n + 3) = -3$

298 Byron has 72 coins in his piggy bank. The piggy bank contains only dimes and quarters. If he has \$14.70 in his piggy bank, which equation can be used to determine q , the number of quarters he has?

1 $14.70 + 0.25q = 72$

2 $0.10(q - 72) + 0.25q = 14.70$

3 $0.10(72 - q) + 0.25q = 14.70$

4 $0.10q + 0.25(72 - q) = 14.70$

A.A.6: MODELING EQUATIONS

299 The ages of three brothers are consecutive even integers. Three times the age of the youngest brother exceeds the oldest brother's age by 48 years. What is the age of the youngest brother?

1 14

2 18

3 22

4 26

300 The sum of three consecutive odd integers is 18 less than five times the middle number. Find the three integers. [Only an algebraic solution can receive full credit.]

A.A.6: VENN DIAGRAMS

301 Monique has three sons who play football, two sons who play baseball, and one son who plays both sports. If all of her sons play baseball or football, how many sons does she have?

1 5

2 6

3 3

4 4

A.A.23: TRANSFORMING FORMULAS

302 If $3ax + b = c$, then x equals

1 $c - b + 3a$

2 $c + b - 3a$

3 $\frac{c - b}{3a}$

4 $\frac{b - c}{3a}$

Integrated Algebra Regents Exam Questions by Performance Indicator: Topic

www.jmap.org

- 303 If the formula for the perimeter of a rectangle is $P = 2l + 2w$, then w can be expressed as

1 $w = \frac{2l - P}{2}$

2 $w = \frac{P - 2l}{2}$

3 $w = \frac{P - l}{2}$

4 $w = \frac{P - 2w}{2l}$

- 304 If $a + ar = b + r$, the value of a in terms of b and r can be expressed as

1 $\frac{b}{r} + 1$

2 $\frac{1 + b}{r}$

3 $\frac{b + r}{1 + r}$

4 $\frac{1 + b}{r + b}$

- 305 The members of the senior class are planning a dance. They use the equation $r = pn$ to determine the total receipts. What is n expressed in terms of r and p ?

1 $n = r + p$

2 $n = r - p$

3 $n = \frac{p}{r}$

4 $n = \frac{r}{p}$

- 306 A formula used for calculating velocity is $v = \frac{1}{2}at^2$. What is a expressed in terms of v and t ?

1 $a = \frac{2v}{t}$

2 $a = \frac{2v}{t^2}$

3 $a = \frac{v}{t}$

4 $a = \frac{v}{2t^2}$

- 307 If $\frac{ey}{n} + k = t$, what is y in terms of e , n , k , and t ?

1 $y = \frac{tn + k}{e}$

2 $y = \frac{tn - k}{e}$

3 $y = \frac{n(t + k)}{e}$

4 $y = \frac{n(t - k)}{e}$

- 308 Solve for c in terms of a and b : $bc + ac = ab$

- 309 If $s = \frac{2x + t}{r}$, then x equals

1 $\frac{rs - t}{2}$

2 $\frac{rs + 1}{2}$

3 $2rs - t$

4 $rs - 2t$

- 310 If $k = am + 3mx$, the value of m in terms of a , k , and x can be expressed as

1 $\frac{k}{a + 3x}$

2 $\frac{k - 3mx}{a}$

3 $\frac{k - am}{3x}$

4 $\frac{k - a}{3x}$

- 311 The formula for the volume of a pyramid is $V = \frac{1}{3}Bh$. What is h expressed in terms of B and V ?

1 $h = \frac{1}{3}VB$

2 $h = \frac{V}{3B}$

3 $h = \frac{3V}{B}$

4 $h = 3VB$

312 If $rx - st = r$, which expression represents x ?

- 1 $\frac{r + st}{r}$
- 2 $\frac{r}{r + st}$
- 3 $\frac{r}{r - st}$
- 4 $\frac{r - st}{r}$

313 If $2y + 2w = x$, then w , in terms of x and y , is equal to

- 1 $x - y$
- 2 $\frac{x - 2y}{2}$
- 3 $x + y$
- 4 $\frac{x + 2y}{2}$

314 If $abx - 5 = 0$, what is x in terms of a and b ?

- 1 $x = \frac{5}{ab}$
- 2 $x = -\frac{5}{ab}$
- 3 $x = 5 - ab$
- 4 $x = ab - 5$

315 If $ax + 3 = 7 - bx$, what is x expressed in terms of a and b ?

- 1 $\frac{4}{ab}$
- 2 $-\frac{4}{ab}$
- 3 $\frac{4}{a + b}$
- 4 $-\frac{4}{a + b}$

316 If $z + y = x + xy^2$, what is x expressed in terms of y and z ?

- 1 $\frac{z}{y}$
- 2 $\frac{z}{1 + y}$
- 3 $\frac{z + 1}{y}$
- 4 $\frac{z + y}{1 + y^2}$

RATE

A.M.1: USING RATE

317 Tom drove 290 miles from his college to home and used 23.2 gallons of gasoline. His sister, Ann, drove 225 miles from her college to home and used 15 gallons of gasoline. Whose vehicle had better gas mileage? Justify your answer.

318 Nicole's aerobics class exercises to fast-paced music. If the rate of the music is 120 beats per minute, how many beats would there be in a class that is 0.75 hour long?

- 1 90
- 2 160
- 3 5,400
- 4 7,200

319 Joseph typed a 1,200-word essay in 25 minutes. At this rate, determine how many words he can type in 45 minutes.

320 A cell phone can receive 120 messages per minute. At this rate, how many messages can the phone receive in 150 seconds?

- 1 48
- 2 75
- 3 300
- 4 18,000

- 321 A car uses one gallon of gasoline for every 20 miles it travels. If a gallon of gasoline costs \$3.98, how much will the gas cost, to the *nearest dollar*, to travel 180 miles?
- 1 9
 - 2 36
 - 3 45
 - 4 80

- 322 A student spent 15 minutes painting a 2-foot by 3-foot bulletin board. To the *nearest tenth of a minute*, how long did it take the student to paint 1 square foot?
- 1 0.4
 - 2 1.5
 - 3 2.5
 - 4 3.5

A.M.1: SPEED

- 323 Hannah took a trip to visit her cousin. She drove 120 miles to reach her cousin's house and the same distance back home. It took her 1.2 hours to get halfway to her cousin's house. What was her average speed, in miles per hour, for the first 1.2 hours of the trip? Hannah's average speed for the remainder of the trip to her cousin's house was 40 miles per hour. How long, in hours, did it take her to drive the remaining distance? Traveling home along the same route, Hannah drove at an average rate of 55 miles per hour. After 2 hours her car broke down. How many miles was she from home?
- 324 In a game of ice hockey, the hockey puck took 0.8 second to travel 89 feet to the goal line. Determine the average speed of the puck in feet per second.
- 325 What is the speed, in meters per second, of a paper airplane that flies 24 meters in 6 seconds?
- 1 144
 - 2 30
 - 3 18
 - 4 4

- 326 It takes Tammy 45 minutes to ride her bike 5 miles. At this rate, how long will it take her to ride 8 miles?
- 1 0.89 hour
 - 2 1.125 hours
 - 3 48 minutes
 - 4 72 minutes

- 327 The chart below compares two runners.

Runner	Distance, in miles	Time, in hours
Greg	11	2
Dave	16	3

Based on the information in this chart, state which runner has the faster rate. Justify your answer.

- 328 Steve ran a distance of 150 meters in $1\frac{1}{2}$ minutes. What is his speed in meters per hour?
- 1 6
 - 2 60
 - 3 100
 - 4 6,000
- 329 A hiker walked 12.8 miles from 9:00 a.m. to noon. He walked an additional 17.2 miles from 1:00 p.m. to 6:00 p.m. What is his average rate for the entire walk, in miles per hour?
- 1 3.75
 - 2 3.86
 - 3 4.27
 - 4 7.71
- 330 A turtle and a rabbit are in a race to see who is first to reach a point 100 feet away. The turtle travels at a constant speed of 20 feet per minute for the entire 100 feet. The rabbit travels at a constant speed of 40 feet per minute for the first 50 feet, stops for 3 minutes, and then continues at a constant speed of 40 feet per minute for the last 50 feet. Determine which animal won the race and by how much time.

- 331 In a baseball game, the ball traveled 350.7 feet in 4.2 seconds. What was the average speed of the ball, in feet per second?
- 1 83.5
 - 2 177.5
 - 3 354.9
 - 4 1,472.9
- 332 The distance from Earth to Mars is 136,000,000 miles. A spaceship travels at 31,000 miles per hour. Determine, to the *nearest day*, how long it will take the spaceship to reach Mars.
- 333 Jonathan drove to the airport to pick up his friend. A rainstorm forced him to drive at an average speed of 45 mph, reaching the airport in 3 hours. He drove back home at an average speed of 55 mph. How long, to the nearest tenth of an hour, did the trip home take him?
- 1 2.0 hours
 - 2 2.5 hours
 - 3 2.8 hours
 - 4 3.7 hours
- 334 It takes a snail 500 hours to travel 15 miles. At this rate, how many hours will it take the snail to travel 6 miles?
- 1 0.18
 - 2 5.56
 - 3 150
 - 4 200
- 335 Jen traveled a distance of 170 miles in 2 hours and 45 minutes. Express her speed, in miles per hour, to the *nearest tenth*.

A.M.2: CONVERSIONS

- 336 On a certain day in Toronto, Canada, the temperature was 15° Celsius (C). Using the formula $F = \frac{9}{5}C + 32$, Peter converts this temperature to degrees Fahrenheit (F). Which temperature represents 15°C in degrees Fahrenheit?
- 1 -9
 - 2 35
 - 3 59
 - 4 85
- 337 If the speed of sound is 344 meters per second, what is the approximate speed of sound, in meters per hour?

60 seconds = 1 minute
60 minutes = 1 hour

- 1 20,640
 - 2 41,280
 - 3 123,840
 - 4 1,238,400
- 338 Angela wants to purchase carpeting for her living room. The dimensions of her living room are 12 feet by 12 feet. If carpeting is sold by the square yard, determine how many square yards of carpeting she must purchase.

3 feet = 1 yard
9 square feet = 1 square yard

- 339 Roberta needs ribbon for a craft project. The ribbon sells for \$3.75 per yard. Find the cost, in dollars, for 48 inches of the ribbon.

Integrated Algebra Regents Exam Questions by Performance Indicator: Topic

www.jmap.org

- 340 Mrs. Chen owns two pieces of property. The areas of the properties are 77,120 square feet and 33,500 square feet.

$$43,560 \text{ square feet} = 1 \text{ acre}$$

Find the total number of acres Mrs. Chen owns, to the *nearest hundredth of an acre*.

- 341 Elizabeth is baking chocolate chip cookies. A single batch uses $\frac{3}{4}$ teaspoon of vanilla. If Elizabeth is mixing the ingredients for five batches at the same time, how many tablespoons of vanilla will she use?

$$3 \text{ teaspoons} = 1 \text{ tablespoon}$$

- 1 $1\frac{1}{4}$
- 2 $1\frac{3}{4}$
- 3 $3\frac{3}{4}$
- 4 $5\frac{3}{4}$

- 342 Peter walked 8,900 feet from home to school.

$$1 \text{ mile} = 5,280 \text{ feet}$$

How far, to the *nearest tenth of a mile*, did he walk?

- 1 0.5
- 2 0.6
- 3 1.6
- 4 1.7

- 343 Which expression can be used to change 75 kilometers per hour to meters per minute?

- 1 $\frac{75 \text{ km}}{1 \text{ hr}} \times \frac{1 \text{ km}}{1,000 \text{ m}} \times \frac{1 \text{ hr}}{60 \text{ min}}$
- 2 $\frac{75 \text{ km}}{1 \text{ hr}} \times \frac{1 \text{ km}}{1,000 \text{ m}} \times \frac{60 \text{ min}}{1 \text{ hr}}$
- 3 $\frac{75 \text{ km}}{1 \text{ hr}} \times \frac{1,000 \text{ m}}{1 \text{ km}} \times \frac{1 \text{ hr}}{60 \text{ min}}$
- 4 $\frac{75 \text{ km}}{1 \text{ hr}} \times \frac{1,000 \text{ m}}{1 \text{ km}} \times \frac{60 \text{ min}}{1 \text{ hr}}$

- 344 A soda container holds $5\frac{1}{2}$ gallons of soda. How many ounces of soda does this container hold?

$$\begin{aligned} 1 \text{ quart} &= 32 \text{ ounces} \\ 1 \text{ gallon} &= 4 \text{ quarts} \end{aligned}$$

- 1 44
- 2 176
- 3 640
- 4 704

- 345 A jogger ran at a rate of 5.4 miles per hour. Find the jogger's *exact* rate, in feet per minute.

$$1 \text{ mile} = 5,280 \text{ feet}$$

- 346 A parking lot is 100 yards long. What is the length of $\frac{3}{4}$ of the parking lot, in feet?

$$1 \text{ yard} = 3 \text{ feet}$$

- 1 300
- 2 225
- 3 75
- 4 25

Integrated Algebra Regents Exam Questions by Performance Indicator: Topic

www.jmap.org

- 347 Last year, Nick rode his bicycle a total of 8000 miles. To the *nearest yard*, Nick rode an average of how many yards per day?

1 mile = 1760 yards 1 year = 365 days
--

- 1 22
2 236
3 1659
4 38,575
- 348 A total of 1680 ounces of pet food have to be packed in 5-pound bags. How many 5-pound bags of pet food can be packed?

1 pound = 16 ounces

- 1 21
2 28
3 105
4 336

A.N.5: PERCENTS

- 349 The Hudson Record Store is having a going-out-of-business sale. CDs normally sell for \$18.00. During the first week of the sale, all CDs will sell for \$15.00. Written as a fraction, what is the rate of discount? What is this rate expressed as a percent? Round your answer to the *nearest hundredth of a percent*. During the second week of the sale, the same CDs will be on sale for 25% off the *original* price. What is the price of a CD during the second week of the sale?

- 350 At the end of week one, a stock had increased in value from \$5.75 a share to \$7.50 a share. Find the percent of increase at the end of week one to the *nearest tenth of a percent*. At the end of week two, the same stock had decreased in value from \$7.50 to \$5.75. Is the percent of decrease at the end of week two the same as the percent of increase at the end of week one? Justify your answer.

- 351 In a recent town election, 1,860 people voted for either candidate *A* or candidate *B* for the position of supervisor. If candidate *A* received 55% of the votes, how many votes did candidate *B* receive?

- 1 186
2 837
3 1,023
4 1,805

- 352 Shana wants to buy a new bicycle that has a retail price of \$259.99. She knows that it will be on sale next week for 30% off the retail price. If the tax rate is 7%, find the total amount, to the *nearest cent*, that she will save by waiting until next week.

- 353 Miller's Department Store is having a sale with a 25% discount on mattresses. If the sales tax rate is 8%, how much change will Frank receive from \$800 if he purchases a mattress regularly priced at \$895 during this sale?

- 354 Carla bought a dress at a sale for 20% off the original price. The sale price of the dress was \$28.80. Find the original price of the dress, in dollars.

A.N.5: DIRECT VARIATION

- 355 The table below represents the number of hours a student worked and the amount of money the student earned.

Number of Hours (h)	Dollars Earned (d)
8	\$50.00
15	\$93.75
19	\$118.75
30	\$187.50

Write an equation that represents the number of dollars, d , earned in terms of the number of hours, h , worked. Using this equation, determine the number of dollars the student would earn for working 40 hours.

- 356 The number of calories burned while jogging varies directly with the number of minutes spent jogging. If George burns 150 calories by jogging for 20 minutes, how many calories does he burn by jogging for 30 minutes?
- 1 100
 - 2 180
 - 3 200
 - 4 225

LINEAR EQUATIONS

A.A.32: SLOPE

- 357 In a linear equation, the independent variable increases at a constant rate while the dependent variable decreases at a constant rate. The slope of this line is
- 1 zero
 - 2 negative
 - 3 positive
 - 4 undefined

- 358 The data in the table below are graphed, and the slope is examined.

x	y
0.5	9.0
1	8.75
1.5	8.5
2	8.25
2.5	8.0

The rate of change represented in this table can be described as

- 1 negative
 - 2 positive
 - 3 undefined
 - 4 zero
- 359 In a given linear equation, the value of the independent variable decreases at a constant rate while the value of the dependent variable increases at a constant rate. The slope of this line is
- 1 positive
 - 2 negative
 - 3 zero
 - 4 undefined

A.A.33: SLOPE

- 360 What is the slope of the line containing the points (3, 4) and (-6, 10)?
- 1 $\frac{1}{2}$
 - 2 2
 - 3 $-\frac{2}{3}$
 - 4 $-\frac{3}{2}$

361 What is the slope of the line that passes through the points $(-6, 1)$ and $(4, -4)$?

- 1 -2
- 2 2
- 3 $-\frac{1}{2}$
- 4 $\frac{1}{2}$

362 What is the slope of the line that passes through the points $(2, 5)$ and $(7, 3)$?

- 1 $-\frac{5}{2}$
- 2 $-\frac{2}{5}$
- 3 $\frac{8}{9}$
- 4 $\frac{9}{8}$

363 What is the slope of the line that passes through the points $(-5, 4)$ and $(15, -4)$?

- 1 $-\frac{2}{5}$
- 2 0
- 3 $-\frac{5}{2}$
- 4 undefined

364 In the diagram below, what is the slope of the line passing through points A and B ?

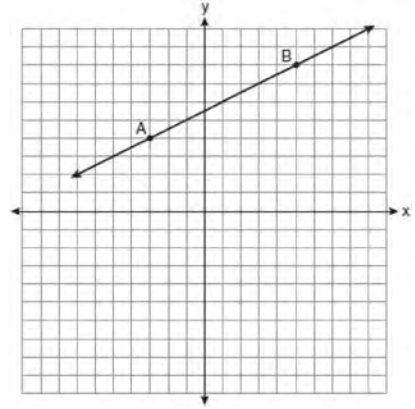

- 1 -2
- 2 2
- 3 $-\frac{1}{2}$
- 4 $\frac{1}{2}$

365 What is the slope of the line that passes through the points $(3, 5)$ and $(-2, 2)$?

- 1 $\frac{1}{5}$
- 2 $\frac{3}{5}$
- 3 $\frac{5}{3}$
- 4 5

- 366 What is the slope of the line passing through the points A and B , as shown on the graph below?

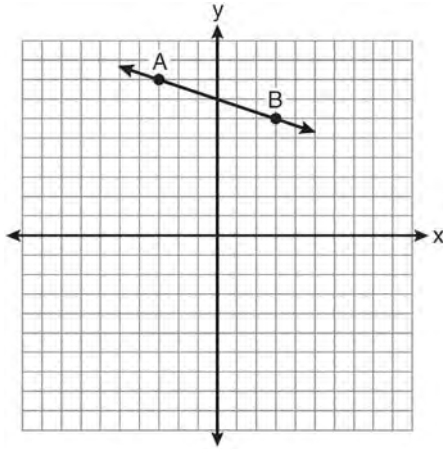

- 1 -3
 2 $-\frac{1}{3}$
 3 3
 4 $\frac{1}{3}$
- 367 What is the slope of the line passing through the points $(-2, 4)$ and $(3, 6)$?
- 1 $-\frac{5}{2}$
 2 $-\frac{2}{5}$
 3 $\frac{2}{5}$
 4 $\frac{5}{2}$
- 368 What is the slope of the line that passes through the points $(2, -3)$ and $(5, 1)$?

- 1 $-\frac{2}{3}$
 2 $\frac{2}{3}$
 3 $-\frac{4}{3}$
 4 $\frac{4}{3}$

- 369 What is the slope of the line that passes through the points $(4, -7)$ and $(9, 1)$?

- 1 $\frac{5}{8}$
 2 $\frac{8}{5}$
 3 $-\frac{6}{12}$
 4 $-\frac{13}{6}$

- 370 What is the slope of a line that passes through the points $(-2, -7)$ and $(-6, -2)$?

- 1 $-\frac{4}{5}$
 2 $-\frac{5}{4}$
 3 $\frac{8}{9}$
 4 $\frac{9}{8}$

- 371 What is the slope of a line passing through points $(-7, 5)$ and $(5, -3)$?

- 1 $-\frac{3}{2}$
 2 $-\frac{2}{3}$
 3 $\frac{2}{3}$
 4 $\frac{3}{2}$

A.A.37: SLOPE

- 372 What is the slope of the line whose equation is $3x - 7y = 9$?

- 1 $-\frac{3}{7}$
 2 $\frac{3}{7}$
 3 $-\frac{7}{3}$
 4 $\frac{7}{3}$

373 The line represented by the equation $2y - 3x = 4$ has a slope of

- 1 $-\frac{3}{2}$
- 2 2
- 3 3
- 4 $\frac{3}{2}$

377 Which linear equation represents a line that has a slope of $\frac{2}{3}$?

- 1 $-2y = -3x + 6$
- 2 $-3y = 2x + 6$
- 3 $3y = -2x + 6$
- 4 $3y = 2x + 6$

374 What is the slope of the line represented by the equation $4x + 3y = 12$?

- 1 $\frac{4}{3}$
- 2 $\frac{3}{4}$
- 3 $-\frac{3}{4}$
- 4 $-\frac{4}{3}$

375 What is the slope of a line represented by the equation $2y = x - 4$?

- 1 1
- 2 $\frac{1}{2}$
- 3 -1
- 4 $-\frac{1}{2}$

376 What is the slope of the line represented by the equation $4x + 3y = 7$?

- 1 $\frac{7}{4}$
- 2 $\frac{7}{3}$
- 3 $-\frac{3}{4}$
- 4 $-\frac{4}{3}$

A.G.4: GRAPHING LINEAR FUNCTIONS

- 378 The gas tank in a car holds a total of 16 gallons of gas. The car travels 75 miles on 4 gallons of gas. If the gas tank is full at the beginning of a trip, which graph represents the rate of change in the amount of gas in the tank?

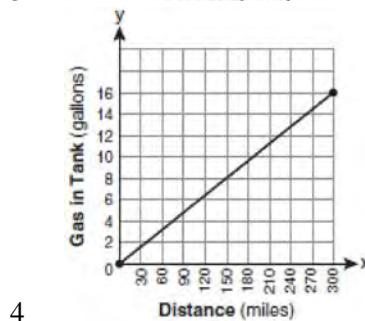
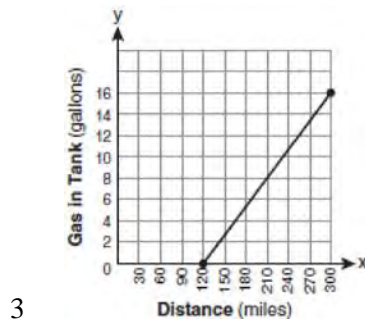
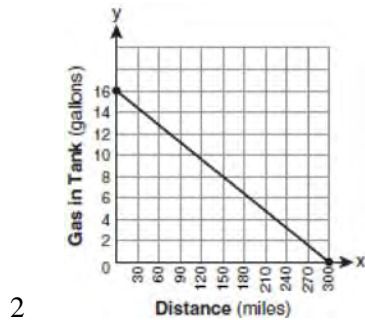
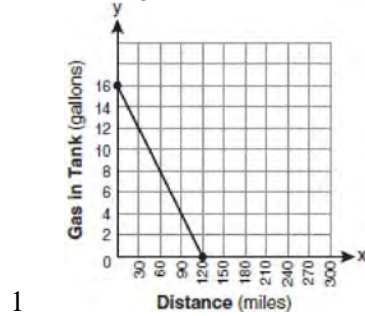

A.A.34: WRITING LINEAR EQUATIONS

- 379 What is an equation of the line that passes through the point $(4, -6)$ and has a slope of -3 ?
- 1 $y = -3x + 6$
 - 2 $y = -3x - 6$
 - 3 $y = -3x + 10$
 - 4 $y = -3x + 14$
- 380 What is an equation of the line that passes through the point $(3, -1)$ and has a slope of 2 ?
- 1 $y = 2x + 5$
 - 2 $y = 2x - 1$
 - 3 $y = 2x - 4$
 - 4 $y = 2x - 7$
- 381 A line having a slope of $\frac{3}{4}$ passes through the point $(-8, 4)$. Write the equation of this line in slope-intercept form.
- 382 Which equation represents the line that passes through the point $(1, 5)$ and has a slope of -2 ?
- 1 $y = -2x + 7$
 - 2 $y = -2x + 11$
 - 3 $y = 2x - 9$
 - 4 $y = 2x + 3$
- 383 Which equation represents a line that has a slope of $\frac{3}{4}$ and passes through the point $(2, 1)$?
- 1 $3y = 4x - 5$
 - 2 $3y = 4x + 2$
 - 3 $4y = 3x - 2$
 - 4 $4y = 3x + 5$
- 384 What is an equation of the line that passes through the point $(-2, -8)$ and has a slope of 3 ?
- 1 $y = 3x - 2$
 - 2 $y = 3x - 22$
 - 3 $y = 3x + 2$
 - 4 $y = 3x + 22$

Integrated Algebra Regents Exam Questions by Performance Indicator: Topic

www.jmap.org

385 What is the equation of the line that passes through the point $(3, -7)$ and has a slope of $-\frac{4}{3}$?

- 1 $y = -\frac{4}{3}x + 3$
- 2 $y = -\frac{4}{3}x - 3$
- 3 $y = \frac{37}{3}x - \frac{4}{3}$
- 4 $y = -\frac{59}{9}x - \frac{4}{3}$

A.A.35: WRITING LINEAR EQUATIONS

386 What is an equation for the line that passes through the coordinates $(2, 0)$ and $(0, 3)$?

- 1 $y = -\frac{3}{2}x + 3$
- 2 $y = -\frac{3}{2}x - 3$
- 3 $y = -\frac{2}{3}x + 2$
- 4 $y = -\frac{2}{3}x - 2$

387 Write an equation that represents the line that passes through the points $(5, 4)$ and $(-5, 0)$.

- 1 $y = 3$
- 2 $x = -3$
- 3 $y = -3$
- 4 $x = y$

388 What is an equation of the line that passes through the points $(3, -3)$ and $(-3, -3)$?

- 1 $y = 3$
- 2 $x = -3$
- 3 $y = -3$
- 4 $x = y$

389 Which equation represents the line that passes through the points $(-3, 7)$ and $(3, 3)$?

- 1 $y = \frac{2}{3}x + 1$
- 2 $y = \frac{2}{3}x + 9$
- 3 $y = -\frac{2}{3}x + 5$
- 4 $y = -\frac{2}{3}x + 9$

390 What is an equation of the line that passes through the points $(1, 3)$ and $(8, 5)$?

- 1 $y + 1 = \frac{2}{7}(x + 3)$
- 2 $y - 5 = \frac{2}{7}(x - 8)$
- 3 $y - 1 = \frac{2}{7}(x + 3)$
- 4 $y + 5 = \frac{2}{7}(x - 8)$

391 Which equation represents the line that passes through the points $(1, 1)$ and $(-2, 7)$?

- 1 $y = -2x + 9$
- 2 $y = -2x + 3$
- 3 $y = -\frac{1}{2}x + 8$
- 4 $y = -\frac{1}{2}x + 6$

392 What is an equation of the line that passes through the points $(2, 1)$ and $(6, -5)$?

- 1 $y = -\frac{3}{2}x - 2$
- 2 $y = -\frac{3}{2}x + 4$
- 3 $y = -\frac{2}{3}x - 1$
- 4 $y = -\frac{2}{3}x + \frac{7}{3}$

393 Which equation represents the line that passes through the points $(-1, -2)$ and $(3, 10)$?

- 1 $y = 3x + 1$
- 2 $y = 3x - 1$
- 3 $y = 4x + 2$
- 4 $y = 4x - 2$

A.A.39: IDENTIFYING POINTS ON A LINE

394 Which point is on the line $4y - 2x = 0$?

- 1 $(-2, -1)$
- 2 $(-2, 1)$
- 3 $(-1, -2)$
- 4 $(1, 2)$

A.A.36: PARALLEL AND PERPENDICULAR LINES

395 Which linear equation represents a line containing the point $(1, 3)$?

- 1 $x + 2y = 5$
- 2 $x - 2y = 5$
- 3 $2x + y = 5$
- 4 $2x - y = 5$

396 Which point lies on the line whose equation is $2x - 3y = 9$?

- 1 $(-1, -3)$
- 2 $(-1, 3)$
- 3 $(0, 3)$
- 4 $(0, -3)$

397 Which point lies on the graph represented by the equation $3y + 2x = 8$?

- 1 $(-2, 7)$
- 2 $(0, 4)$
- 3 $(2, 4)$
- 4 $(7, -2)$

398 Which set of coordinates is a solution of the equation $2x - y = 11$?

- 1 $(-6, 1)$
- 2 $(-1, 9)$
- 3 $(0, 11)$
- 4 $(2, -7)$

399 If the point $(5, k)$ lies on the line represented by the equation $2x + y = 9$, the value of k is

- 1 1
- 2 2
- 3 -1
- 4 -2

400 Which equation represents a line parallel to the x -axis?

- 1 $x = 5$
- 2 $y = 10$
- 3 $x = \frac{1}{3}y$
- 4 $y = 5x + 17$

401 Which equation represents a line parallel to the x -axis?

- 1 $y = -5$
- 2 $y = -5x$
- 3 $x = 3$
- 4 $x = 3y$

402 Which equation represents a line parallel to the y -axis?

- 1 $x = y$
- 2 $x = 4$
- 3 $y = 4$
- 4 $y = x + 4$

403 Which equation represents a line parallel to the y -axis?

- 1 $y = x$
- 2 $y = 3$
- 3 $x = -y$
- 4 $x = -4$

404 Which equation represents the line that passes through the point $(3, 4)$ and is parallel to the x -axis?

- 1 $x = 4$
- 2 $x = -3$
- 3 $y = 4$
- 4 $y = -3$

Integrated Algebra Regents Exam Questions by Performance Indicator: Topic

www.jmap.org

405 Which equation represents a line that is parallel to the y -axis and passes through the point $(4, 3)$?

- 1 $x = 3$
- 2 $x = 4$
- 3 $y = 3$
- 4 $y = 4$

406 Which equation represents a line that is parallel to the y -axis?

- 1 $x = 5$
- 2 $x = 5y$
- 3 $y = 5$
- 4 $y = 5x$

407 Which equation represents a vertical line?

- 1 $y = -x$
- 2 $y = 12$
- 3 $x = y$
- 4 $x = 12$

408 The graph of the equation $y = -2$ is a line

- 1 parallel to the x -axis
- 2 parallel to the y -axis
- 3 passing through the origin
- 4 passing through the point $(-2, 0)$

A.A.38: PARALLEL AND PERPENDICULAR LINES

409 Which equation represents a line that is parallel to the line $y = -4x + 5$?

- 1 $y = -4x + 3$
- 2 $y = -\frac{1}{4}x + 5$
- 3 $y = \frac{1}{4}x + 3$
- 4 $y = 4x + 5$

410 Which equation represents a line that is parallel to the line $y = 3 - 2x$?

- 1 $4x + 2y = 5$
- 2 $2x + 4y = 1$
- 3 $y = 3 - 4x$
- 4 $y = 4x - 2$

411 Which equation represents a line parallel to the graph of $2x - 4y = 16$?

- 1 $y = \frac{1}{2}x - 5$
- 2 $y = -\frac{1}{2}x + 4$
- 3 $y = -2x + 6$
- 4 $y = 2x + 8$

412 The graphs of the equations $y = 2x - 7$ and $y - kx = 7$ are parallel when k equals

- 1 -2
- 2 2
- 3 -7
- 4 7

413 Which equation represents a line that is parallel to the line whose equation is $2x - 3y = 9$?

- 1 $y = \frac{2}{3}x - 4$
- 2 $y = -\frac{2}{3}x + 4$
- 3 $y = \frac{3}{2}x - 4$
- 4 $y = -\frac{3}{2}x + 4$

414 Which equation represents a line that is parallel to the line whose equation is $y = -3x - 7$?

- 1 $y = -3x + 4$
- 2 $y = -\frac{1}{3}x - 7$
- 3 $y = \frac{1}{3}x + 5$
- 4 $y = 3x - 2$

415 Which equation represents a line that is parallel to the line whose equation is $y = -3x$?

- 1 $\frac{1}{3}x + y = 4$
- 2 $-\frac{1}{3}x + y = 4$
- 3 $6x + 2y = 4$
- 4 $-6x + 2y = 4$

INEQUALITIES

A.A.24: SOLVING INEQUALITIES

416 What is the solution of $3(2m - 1) \leq 4m + 7$?

- 1 $m \leq 5$
- 2 $m \geq 5$
- 3 $m \leq 4$
- 4 $m \geq 4$

417 What is the solution of the inequality $-6x - 17 \geq 8x + 25$?

- 1 $x \geq 3$
- 2 $x \leq 3$
- 3 $x \geq -3$
- 4 $x \leq -3$

418 Solve algebraically for x : $2(x - 4) \geq \frac{1}{2}(5 - 3x)$

419 Solve the inequality $-5(x - 7) < 15$ algebraically for x .

420 Which graph represents the solution set of $2x - 5 < 3$?

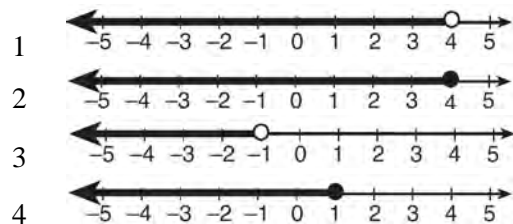

421 What is the solution of $4x - 30 \geq -3x + 12$?

- 1 $x \geq 6$
- 2 $x \leq 6$
- 3 $x \geq -6$
- 4 $x \leq -6$

A.A.21: INTERPRETING SOLUTIONS

422 Which value of x is in the solution set of the inequality $-2x + 5 > 17$?

- 1 -8
- 2 -6
- 3 -4
- 4 12

423 Which value of x is in the solution set of the inequality $-4x + 2 > 10$?

- 1 -2
- 2 2
- 3 3
- 4 -4

424 Which value of x is in the solution set of

$$\frac{4}{3}x + 5 < 17?$$

- 1 8
- 2 9
- 3 12
- 4 16

425 Which value of x is in the solution set of the inequality $-2(x - 5) < 4$?

- 1 0
- 2 2
- 3 3
- 4 5

426 Given: $A = \{18, 6, -3, -12\}$

Determine all elements of set A that are in the solution of the inequality $\frac{2}{3}x + 3 < -2x - 7$.

427 Which value of x is in the solution set of $-3x + 8 \geq 14$?

- 1 -3
- 2 -1
- 3 0
- 4 3

- 428 The statement $|-15| < x < |-20|$ is true when x is equal to
- 1 -16
 - 2 -14
 - 3 17
 - 4 21

- 429 Which value of x is a solution of the inequality $25x - 100 < 250$?
- 1 13
 - 2 14
 - 3 15
 - 4 16

A.A.4: MODELING INEQUALITIES

- 430 Mrs. Smith wrote "Eight less than three times a number is greater than fifteen" on the board. If x represents the number, which inequality is a correct translation of this statement?
- 1 $3x - 8 > 15$
 - 2 $3x - 8 < 15$
 - 3 $8 - 3x > 15$
 - 4 $8 - 3x < 15$

- 431 The sign shown below is posted in front of a roller coaster ride at the Wadsworth County Fairgrounds.

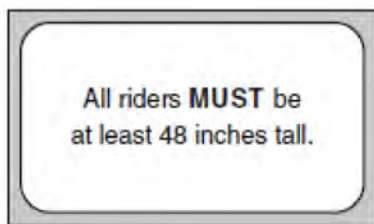

If h represents the height of a rider in inches, what is a correct translation of the statement on this sign?

- 1 $h < 48$
- 2 $h > 48$
- 3 $h \leq 48$
- 4 $h \geq 48$

- 432 If Rosa's age is represented by R , which inequality represents the statement "Rosa is at most 29 years old"?
- 1 $R < 29$
 - 2 $R > 29$
 - 3 $R \leq 29$
 - 4 $R \geq 29$

A.A.5: MODELING INEQUALITIES

- 433 An electronics store sells DVD players and cordless telephones. The store makes a \$75 profit on the sale of each DVD player (d) and a \$30 profit on the sale of each cordless telephone (c). The store wants to make a profit of at least \$255.00 from its sales of DVD players and cordless phones. Which inequality describes this situation?

- 1 $75d + 30c < 255$
- 2 $75d + 30c \leq 255$
- 3 $75d + 30c > 255$
- 4 $75d + 30c \geq 255$

- 434 Students in a ninth grade class measured their heights, h , in centimeters. The height of the shortest student was 155 cm, and the height of the tallest student was 190 cm. Which inequality represents the range of heights?

- 1 $155 < h < 190$
- 2 $155 \leq h \leq 190$
- 3 $h \geq 155$ or $h \leq 190$
- 4 $h > 155$ or $h < 190$

- 435 Roger is having a picnic for 78 guests. He plans to serve each guest at least one hot dog. If each package, p , contains eight hot dogs, which inequality could be used to determine how many packages of hot dogs Roger will need to buy?

- 1 $p \geq 78$
- 2 $8p \geq 78$
- 3 $8 + p \geq 78$
- 4 $78 - p \geq 8$

- 436 The ninth grade class at a local high school needs to purchase a park permit for \$250.00 for their upcoming class picnic. Each ninth grader attending the picnic pays \$0.75. Each guest pays \$1.25. If 200 ninth graders attend the picnic, which inequality can be used to determine the number of guests, x , needed to cover the cost of the permit?
- 1 $0.75x - (1.25)(200) \geq 250.00$
 - 2 $0.75x + (1.25)(200) \geq 250.00$
 - 3 $(0.75)(200) - 1.25x \geq 250.00$
 - 4 $(0.75)(200) + 1.25x \geq 250.00$
- 437 The length of a rectangle is 15 and its width is w . The perimeter of the rectangle is, *at most*, 50. Which inequality can be used to find the longest possible width?
- 1 $30 + 2w < 50$
 - 2 $30 + 2w \leq 50$
 - 3 $30 + 2w > 50$
 - 4 $30 + 2w \geq 50$
- 438 Carol plans to sell twice as many magazine subscriptions as Jennifer. If Carol and Jennifer need to sell at least 90 subscriptions in all, which inequality could be used to determine how many subscriptions, x , Jennifer needs to sell?
- 1 $x \geq 45$
 - 2 $2x \geq 90$
 - 3 $2x - x \geq 90$
 - 4 $2x + x \geq 90$
- 439 Jeremy is hosting a Halloween party for 80 children. He will give each child *at least* one candy bar. If each bag of candy contains 18 candy bars, which inequality can be used to determine how many bags, c , Jeremy will need to buy?
- 1 $18c \geq 80$
 - 2 $18c \leq 80$
 - 3 $\frac{c}{18} \geq 80$
 - 4 $\frac{c}{18} \leq 80$
- 440 The length of a rectangle is three feet less than twice its width. If x represents the width of the rectangle, in feet, which inequality represents the area of the rectangle that is *at most* 30 square feet?
- 1 $x(2x - 3) \leq 30$
 - 2 $x(2x - 3) \geq 30$
 - 3 $x(3 - 2x) \leq 30$
 - 4 $x(3 - 2x) \geq 30$
- A.A.6: MODELING INEQUALITIES
- 441 A prom ticket at Smith High School is \$120. Tom is going to save money for the ticket by walking his neighbor's dog for \$15 per week. If Tom already has saved \$22, what is the minimum number of weeks Tom must walk the dog to earn enough to pay for the prom ticket?
- 442 Peter begins his kindergarten year able to spell 10 words. He is going to learn to spell 2 new words every day. Write an inequality that can be used to determine how many days, d , it takes Peter to be able to spell *at least* 75 words. Use this inequality to determine the minimum number of whole days it will take for him to be able to spell *at least* 75 words.
- 443 Tamara has a cell phone plan that charges \$0.07 per minute plus a monthly fee of \$19.00. She budgets \$29.50 per month for total cell phone expenses without taxes. What is the maximum number of minutes Tamara could use her phone each month in order to stay within her budget?
- 1 150
 - 2 271
 - 3 421
 - 4 692

444 An online music club has a one-time registration fee of \$13.95 and charges \$0.49 to buy each song. If Emma has \$50.00 to join the club and buy songs, what is the maximum number of songs she can buy?

- 1 73
- 2 74
- 3 130
- 4 131

445 Chelsea has \$45 to spend at the fair. She spends \$20 on admission and \$15 on snacks. She wants to play a game that costs \$0.65 per game. Write an inequality to find the maximum number of times, x , Chelsea can play the game. Using this inequality, determine the maximum number of times she can play the game.

446 If five times a number is less than 55, what is the greatest possible integer value of the number?

- 1 12
- 2 11
- 3 10
- 4 9

447 Jason's part-time job pays him \$155 a week. If he has already saved \$375, what is the minimum number of weeks he needs to work in order to have enough money to buy a dirt bike for \$900?

- 1 8
- 2 9
- 3 3
- 4 4

448 Tony makes a phone call at a pay phone. The charge is 25 cents for the first four minutes, and 10 cents for each additional minute. Tony has \$2.10 in change in his pocket. Write an inequality that can be used to find m , the maximum number of minutes that Tony can talk on the phone. Solve this inequality algebraically to find the maximum number of whole minutes he can talk on the phone.

A.G.6: LINEAR INEQUALITIES

449 Which inequality is represented by the graph below?

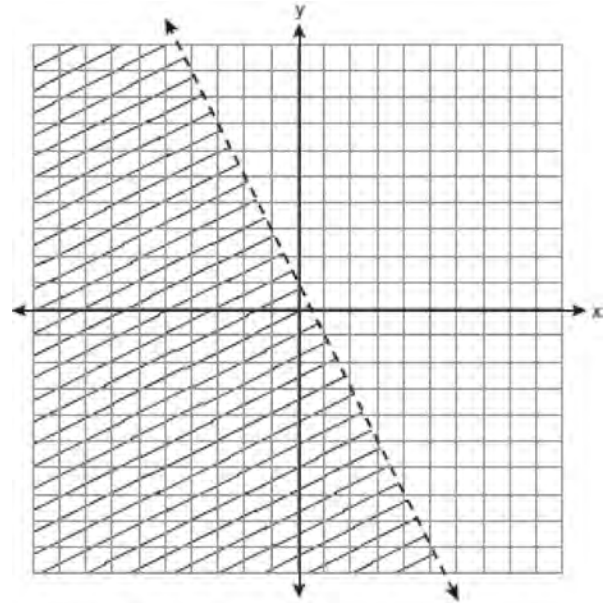

- 1 $y < 2x + 1$
- 2 $y < -2x + 1$
- 3 $y < \frac{1}{2}x + 1$
- 4 $y < -\frac{1}{2}x + 1$

450 Which graph represents the solution of $3y - 9 \leq 6x$?

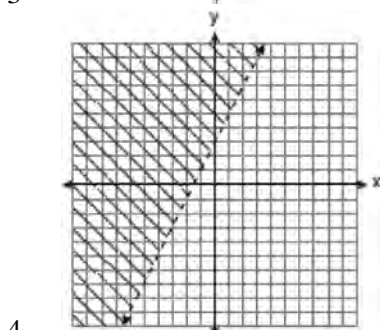
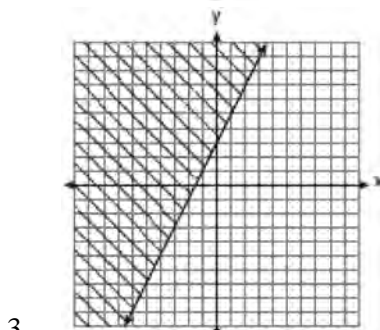
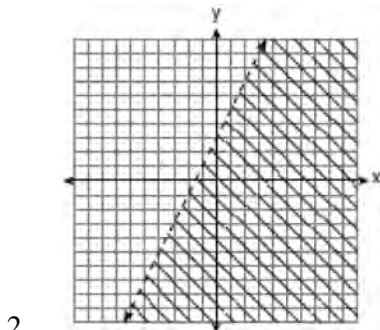
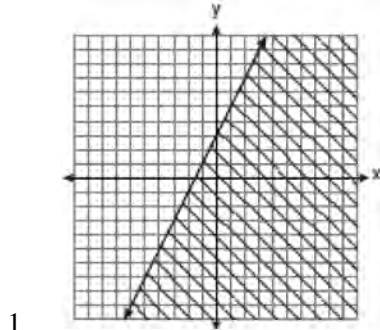

451 Graph the solution set for the inequality $4x - 3y > 9$ on the set of axes below. Determine if the point $(1, -3)$ is in the solution set. Justify your answer.

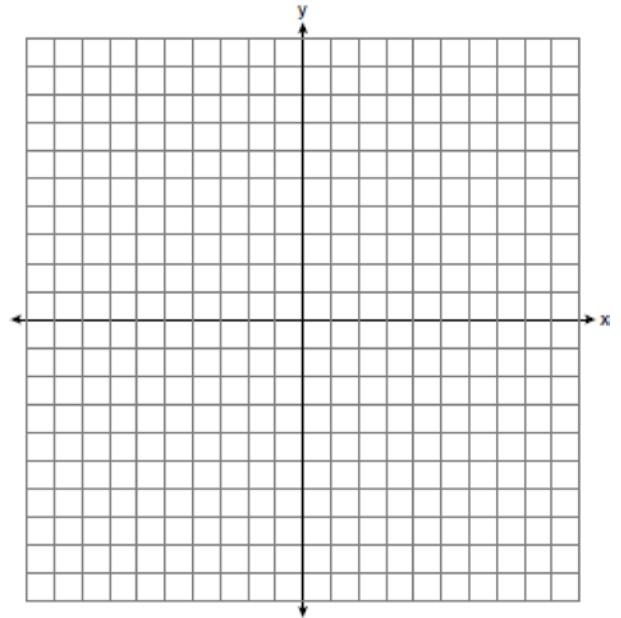

452 Which quadrant will be completely shaded in the graph of the inequality $y \leq 2x$?

- 1 Quadrant I
- 2 Quadrant II
- 3 Quadrant III
- 4 Quadrant IV

453 Which graph represents the inequality $y > 3$?

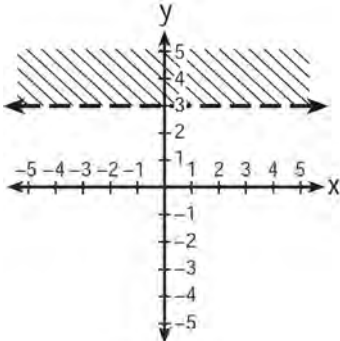

1

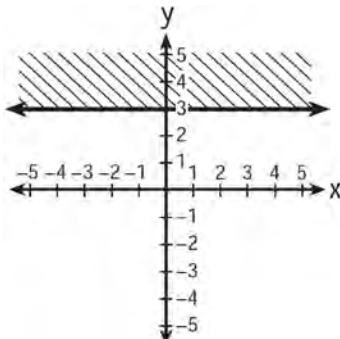

2

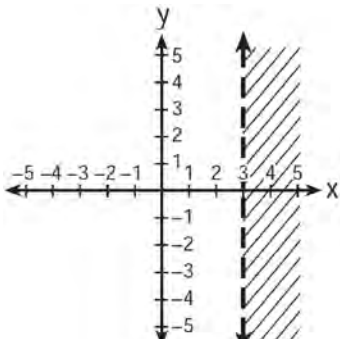

3

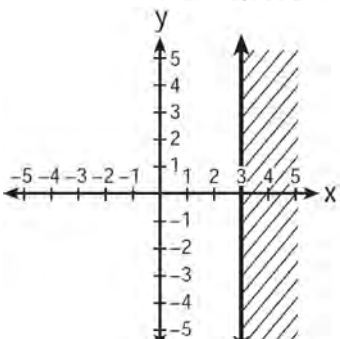

4

454 The diagram below shows the graph of which inequality?

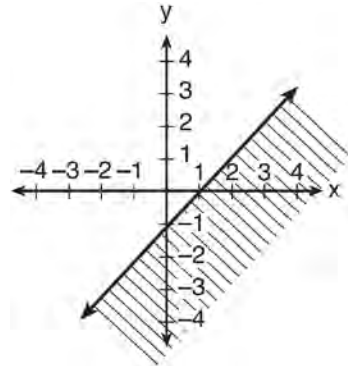

- 1 $y > x - 1$
- 2 $y \geq x - 1$
- 3 $y < x - 1$
- 4 $y \leq x - 1$

455 Which graph represents the inequality $y \geq x + 3$?

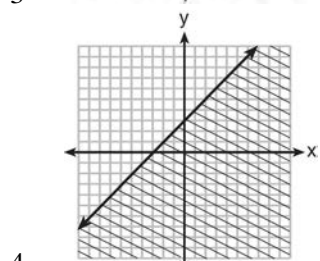
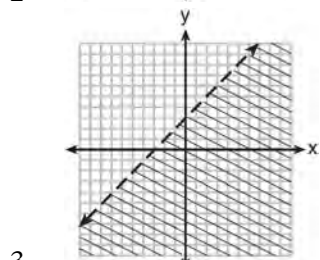
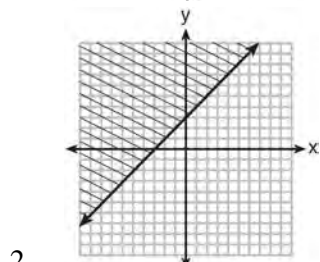
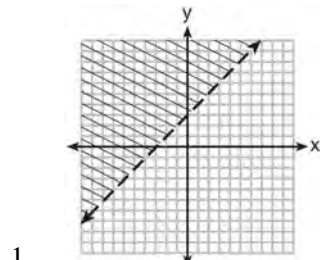

456 Which graph represents the solution of $2y + 6 > 4x$?

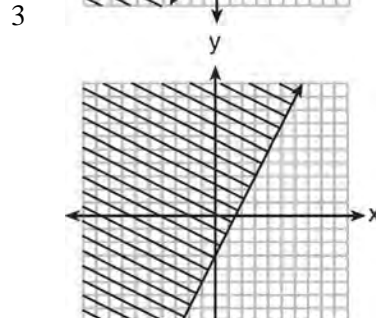
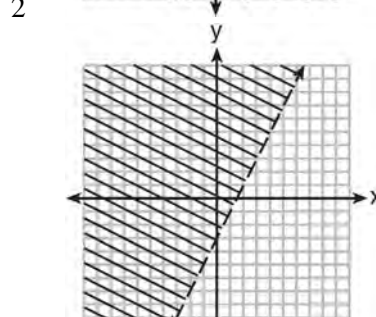
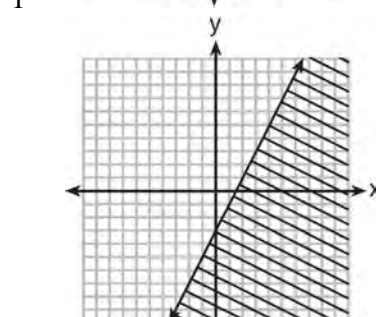
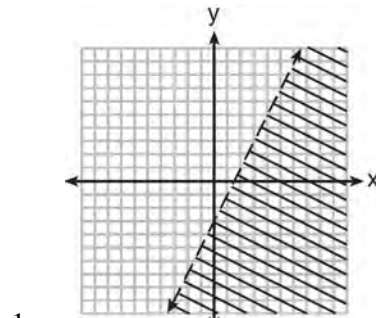

457 Which inequality is shown in the graph below?

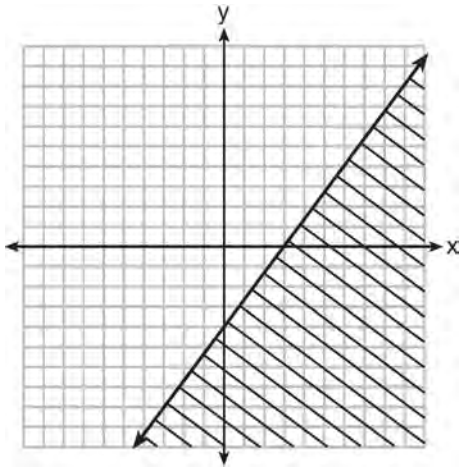

- 1 $y \leq \frac{4}{3}x + 3$
- 2 $y \geq \frac{4}{3}x + 3$
- 3 $y \leq \frac{4}{3}x - 4$
- 4 $y \geq \frac{4}{3}x - 4$

ABSOLUTE VALUE

A.G.4: GRAPHING ABSOLUTE VALUE FUNCTIONS

458 Which is the graph of $y = |x| + 2$?

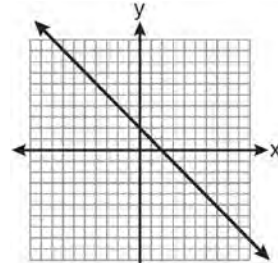

1

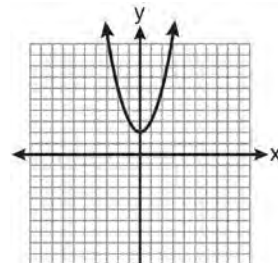

2

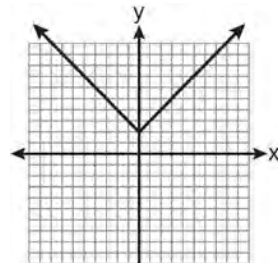

3

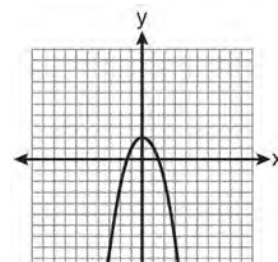

4

459 On the set of axes below, graph $y = 2|x + 3|$.
Include the interval $-7 \leq x \leq 1$.

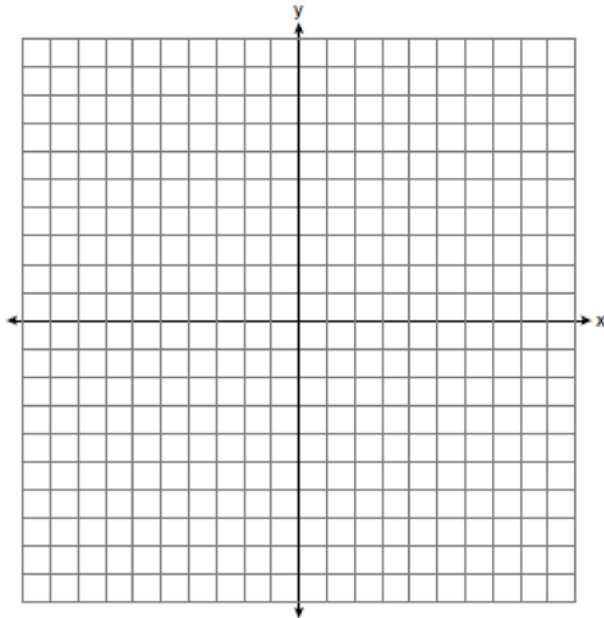

460 Which graph represents the equation $y = |x - 2|$?

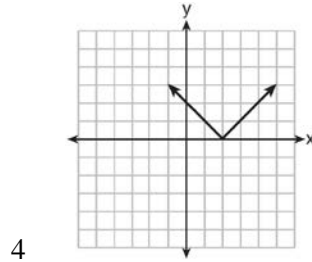
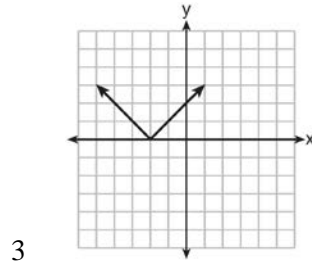
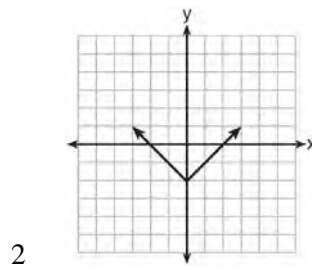
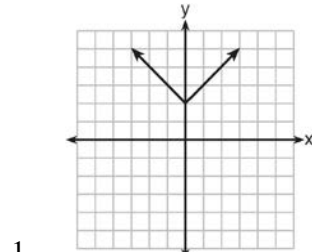

A.G.5: GRAPHING ABSOLUTE VALUE FUNCTIONS

461 The diagram below shows the graph of $y = |x - 3|$.

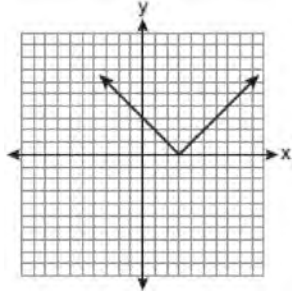

Which diagram shows the graph of $y = -|x - 3|$?

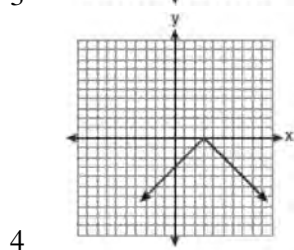
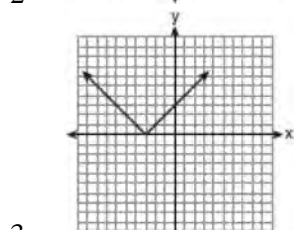
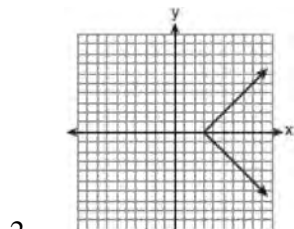
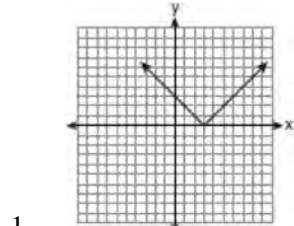

462 The graph of the equation $y = |x|$ is shown in the diagram below.

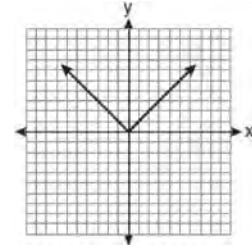

Which diagram could represent a graph of the equation $y = a|x|$ when $-1 < a < 0$?

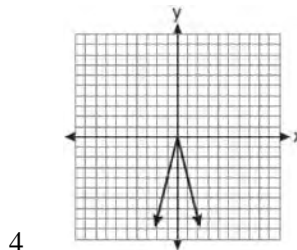
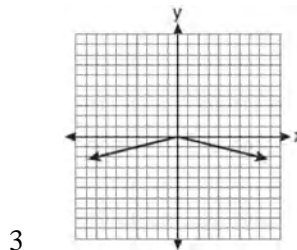
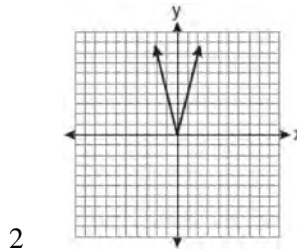
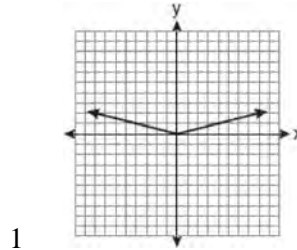

- 463 Graph and label the following equations on the set of axes below.

$$y = |x|$$

$$y = \left| \frac{1}{2}x \right|$$

Explain how *decreasing* the coefficient of x affects the graph of the equation $y = |x|$.

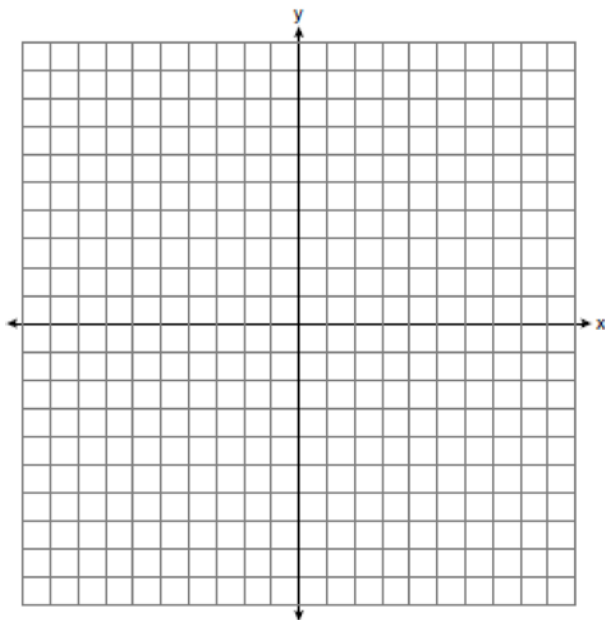

- 464 On the set of axes below, graph and label the equations $y = |x|$ and $y = 3|x|$ for the interval $-3 \leq x \leq 3$.

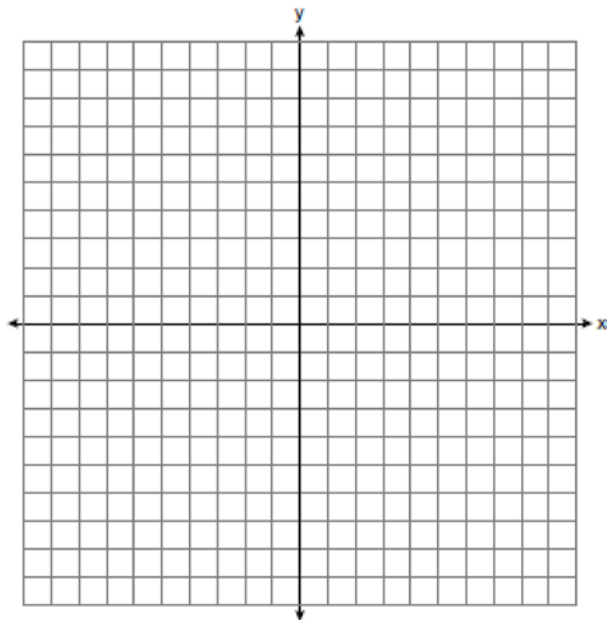

Explain how changing the coefficient of the absolute value from 1 to 3 affects the graph.

465 The graph of $y = |x + 2|$ is shown below.

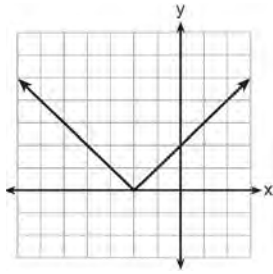

Which graph represents $y = -|x + 2|$?

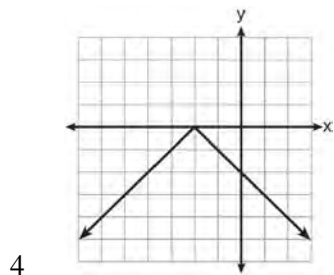
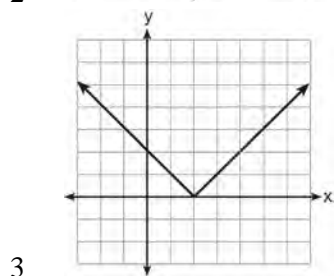
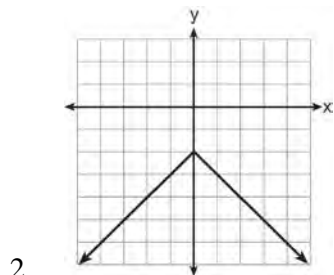
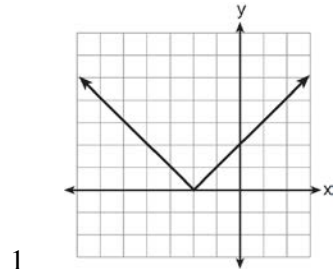

466 Graph and label the functions $y = |x|$ and $y = |2x|$ on the set of axes below.

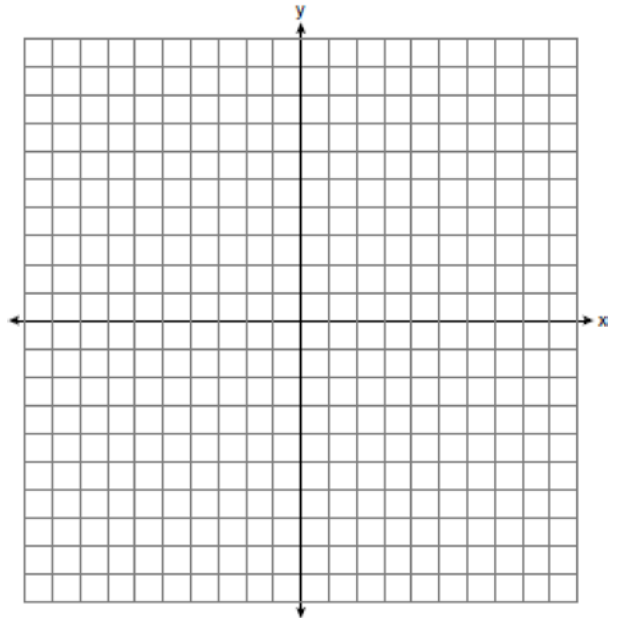

Explain how increasing the coefficient of x affects the graph of $y = |x|$.

467 Dominick graphs the equation $y = a|x|$ where a is a positive integer. If Gina multiplies a by -3 , the new graph will become

- 1 narrower and open downward
- 2 narrower and open upward
- 3 wider and open downward
- 4 wider and open upward

QUADRATICS

A.A.20: FACTORING POLYNOMIALS

468 Factored completely, the expression $2x^2 + 10x - 12$ is equivalent to

- 1 $2(x - 6)(x + 1)$
- 2 $2(x + 6)(x - 1)$
- 3 $2(x + 2)(x + 3)$
- 4 $2(x - 2)(x - 3)$

469 Factored completely, the expression $3x^2 - 3x - 18$ is equivalent to

- 1 $3(x^2 - x - 6)$
- 2 $3(x - 3)(x + 2)$
- 3 $(3x - 9)(x + 2)$
- 4 $(3x + 6)(x - 3)$

470 What are the factors of the expression $x^2 + x - 20$?

- 1 $(x + 5)$ and $(x + 4)$
- 2 $(x + 5)$ and $(x - 4)$
- 3 $(x - 5)$ and $(x + 4)$
- 4 $(x - 5)$ and $(x - 4)$

471 Factored completely, the expression $3x^3 - 33x^2 + 90x$ is equivalent to

- 1 $3x(x^2 - 33x + 90)$
- 2 $3x(x^2 - 11x + 30)$
- 3 $3x(x + 5)(x + 6)$
- 4 $3x(x - 5)(x - 6)$

472 Factor completely: $5x^3 - 20x^2 - 60x$

473 The greatest common factor of $3m^2n + 12mn^2$ is?

- 1 $3n$
- 2 $3m$
- 3 $3mn$
- 4 $3mn^2$

474 When factored completely, the expression

$3x^2 - 9x + 6$ is equivalent to

- 1 $(3x - 3)(x - 2)$
- 2 $(3x + 3)(x - 2)$
- 3 $3(x + 1)(x - 2)$
- 4 $3(x - 1)(x - 2)$

A.A.19: FACTORING THE DIFFERENCE OF PERFECT SQUARES

475 The expression $x^2 - 16$ is equivalent to

- 1 $(x + 2)(x - 8)$
- 2 $(x - 2)(x + 8)$
- 3 $(x + 4)(x - 4)$
- 4 $(x + 8)(x - 8)$

476 Factored, the expression $16x^2 - 25y^2$ is equivalent to

- 1 $(4x - 5y)(4x + 5y)$
- 2 $(4x - 5y)(4x - 5y)$
- 3 $(8x - 5y)(8x + 5y)$
- 4 $(8x - 5y)(8x - 5y)$

477 The expression $9x^2 - 100$ is equivalent to

- 1 $(9x - 10)(x + 10)$
- 2 $(3x - 10)(3x + 10)$
- 3 $(3x - 100)(3x - 1)$
- 4 $(9x - 100)(x + 1)$

478 Factor completely: $4x^3 - 36x$

479 Which expression is equivalent to $9x^2 - 16$?

- 1 $(3x + 4)(3x - 4)$
- 2 $(3x - 4)(3x - 4)$
- 3 $(3x + 8)(3x - 8)$
- 4 $(3x - 8)(3x - 8)$

480 If Ann correctly factors an expression that is the difference of two perfect squares, her factors could be

- 1 $(2x + y)(x - 2y)$
- 2 $(2x + 3y)(2x - 3y)$
- 3 $(x - 4)(x - 4)$
- 4 $(2y - 5)(y - 5)$

Integrated Algebra Regents Exam Questions by Performance Indicator: Topic

www.jmap.org

481 Which expression is equivalent to $121 - x^2$?

- 1 $(x - 11)(x - 11)$
- 2 $(x + 11)(x - 11)$
- 3 $(11 - x)(11 + x)$
- 4 $(11 - x)(11 - x)$

482 When $a^3 - 4a$ is factored completely, the result is

- 1 $(a - 2)(a + 2)$
- 2 $a(a - 2)(a + 2)$
- 3 $a^2(a - 4)$
- 4 $a(a - 2)^2$

483 The expression $x^2 - 36y^2$ is equivalent to

- 1 $(x - 6y)(x - 6y)$
- 2 $(x - 18y)(x - 18y)$
- 3 $(x + 6y)(x - 6y)$
- 4 $(x + 18y)(x - 18y)$

484 Which expression represents $36x^2 - 100y^6$ factored completely?

- 1 $2(9x + 25y^3)(9x - 25y^3)$
- 2 $4(3x + 5y^3)(3x - 5y^3)$
- 3 $(6x + 10y^3)(6x - 10y^3)$
- 4 $(18x + 50y^3)(18x - 50y^3)$

485 Which expression is equivalent to $64 - x^2$?

- 1 $(8 - x)(8 - x)$
- 2 $(8 - x)(8 + x)$
- 3 $(x - 8)(x - 8)$
- 4 $(x - 8)(x + 8)$

486 The expression $9a^2 - 64b^2$ is equivalent to

- 1 $(9a - 8b)(a + 8b)$
- 2 $(9a - 8b)(a - 8b)$
- 3 $(3a - 8b)(3a + 8b)$
- 4 $(3a - 8b)(3a - 8b)$

487 The expression $100n^2 - 1$ is equivalent to

- 1 $(10n + 1)(10n - 1)$
- 2 $(10n - 1)(10n - 1)$
- 3 $(50n + 1)(50n - 1)$
- 4 $(50n - 1)(50n - 1)$

488 When $9x^2 - 100$ is factored, it is equivalent to $(3x - b)(3x + b)$. What is a value for b ?

- 1 50
- 2 10
- 3 3
- 4 100

489 Which expression is equivalent to $81 - 16x^2$?

- 1 $(9 - 8x)(9 + 8x)$
- 2 $(9 - 8x)(9 + 2x)$
- 3 $(9 - 4x)(9 + 4x)$
- 4 $(9 - 4x)(9 - 4x)$

A.A.27: SOLVING QUADRATICS BY FACTORING

490 The solution to the equation $x^2 - 6x = 0$ is

- 1 0, only
- 2 6, only
- 3 0 and 6
- 4 $\pm\sqrt{6}$

491 The solutions of $x^2 = 16x - 28$ are

- 1 -2 and -14
- 2 2 and 14
- 3 -4 and -7
- 4 4 and 7

A.A.28: ROOTS OF QUADRATICS

492 What are the roots of the equation

- $x^2 - 10x + 21 = 0$?
- 1 1 and 21
 - 2 -5 and -5
 - 3 3 and 7
 - 4 -3 and -7

Integrated Algebra Regents Exam Questions by Performance Indicator: Topic

- 493 What are the roots of the equation $x^2 - 7x + 6 = 0$?
- 1 1 and 7
 - 2 -1 and 7
 - 3 -1 and -6
 - 4 1 and 6
- 494 Find the roots of the equation $x^2 - x = 6$ algebraically.
- 495 Find the roots of the equation $x^2 = 30 - 13x$ algebraically.
- 496 Which equation has roots of -3 and 5?
- 1 $x^2 + 2x - 15 = 0$
 - 2 $x^2 - 2x - 15 = 0$
 - 3 $x^2 + 2x + 15 = 0$
 - 4 $x^2 - 2x + 15 = 0$
- 497 What are the roots of the equation $x^2 - 5x + 6 = 0$?
- 1 1 and -6
 - 2 2 and 3
 - 3 -1 and 6
 - 4 -2 and -3
- 498 The roots of the equation $3x^2 - 27x = 0$ are
- 1 0 and 9
 - 2 0 and -9
 - 3 0 and 3
 - 4 0 and -3
- 499 The roots of the equation $x^2 - 14x + 48 = 0$ are
- 1 -6 and -8
 - 2 -6 and 8
 - 3 6 and -8
 - 4 6 and 8
- 500 If the roots of a quadratic equation are -2 and 3, the equation can be written as
- 1 $(x - 2)(x + 3) = 0$
 - 2 $(x + 2)(x - 3) = 0$
 - 3 $(x + 2)(x + 3) = 0$
 - 4 $(x - 2)(x - 3) = 0$
- 501 The roots of the equation $2x^2 - 8x = 0$ are
- 1 -2 and 2
 - 2 0, -2 and 2
 - 3 0 and -4
 - 4 0 and 4
- 502 If the roots of a quadratic equation are -4 and 2, the equation is equivalent to
- 1 $(x + 4)(x - 2) = 0$
 - 2 $(x - 4)(x + 2) = 0$
 - 3 $(x + 4)(x + 2) = 0$
 - 4 $(x - 4)(x - 2) = 0$
- 503 Write a quadratic equation in standard form that has roots of -12 and 2.

A.G.5: GRAPHING QUADRATIC FUNCTIONS

- 504 Consider the graph of the equation $y = ax^2 + bx + c$, when $a \neq 0$. If a is multiplied by 3, what is true of the graph of the resulting parabola?
- 1 The vertex is 3 units above the vertex of the original parabola.
 - 2 The new parabola is 3 units to the right of the original parabola.
 - 3 The new parabola is wider than the original parabola.
 - 4 The new parabola is narrower than the original parabola.

505 The diagram below shows the graph of $y = -x^2 - c$.

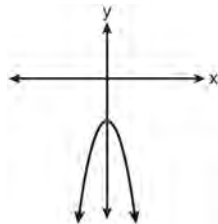

Which diagram shows the graph of $y = x^2 - c$?

- 1
- 2
- 3
- 4

506 Melissa graphed the equation $y = x^2$ and Dave

graphed the equation $y = -3x^2$ on the same coordinate grid. What is the relationship between the graphs that Melissa and Dave drew?

- 1 Dave's graph is wider and opens in the opposite direction from Melissa's graph.
- 2 Dave's graph is narrower and opens in the opposite direction from Melissa's graph.
- 3 Dave's graph is wider and is three units below Melissa's graph.
- 4 Dave's graph is narrower and is three units to the left of Melissa's graph.

507 The graph of a parabola is represented by the

equation $y = ax^2$ where a is a positive integer. If a is multiplied by 2, the new parabola will become

- 1 narrower and open downward
- 2 narrower and open upward
- 3 wider and open downward
- 4 wider and open upward

508 How is the graph of $y = x^2 + 4x + 3$ affected when the coefficient of x^2 is changed to a smaller positive number?

- 1 The graph becomes wider, and the y -intercept changes.
- 2 The graph becomes wider, and the y -intercept stays the same.
- 3 The graph becomes narrower, and the y -intercept changes.
- 4 The graph becomes narrower, and the y -intercept stays the same.

509 Which is the equation of a parabola that has the same vertex as the parabola represented by $y = x^2$, but is wider?

- 1 $y = x^2 + 2$
- 2 $y = x^2 - 2$
- 3 $y = 2x^2$
- 4 $y = \frac{1}{2}x^2$

510 The graph of the equation $y = x^2$ is shown below.

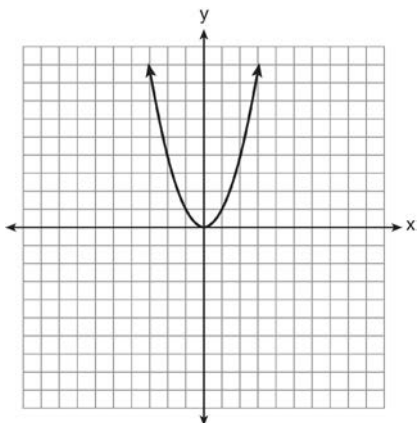

Which statement best describes the change in this graph when the coefficient of x^2 is multiplied by 4?

- 1 The parabola becomes wider.
- 2 The parabola becomes narrower.
- 3 The parabola will shift up four units.
- 4 The parabola will shift right four units.

511 The graph of $y = x^2$ is shown below.

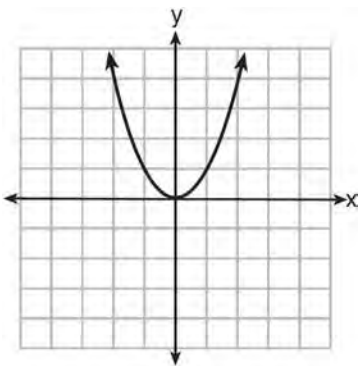

Which graph represents $y = 2x^2$?

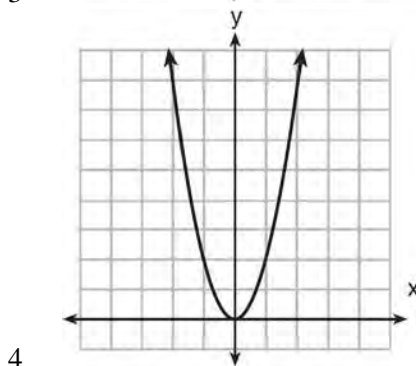
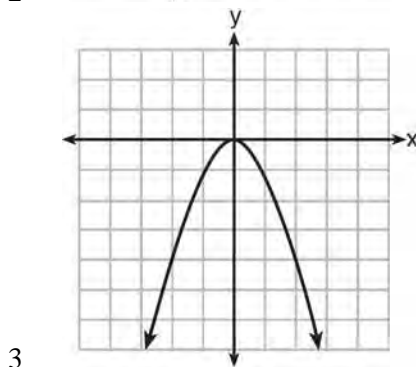
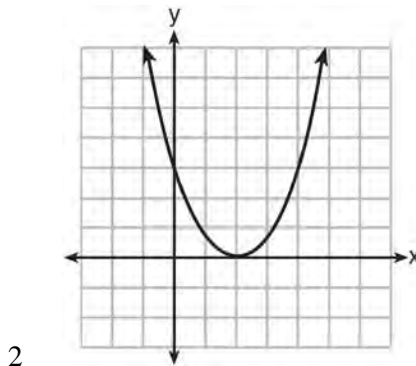
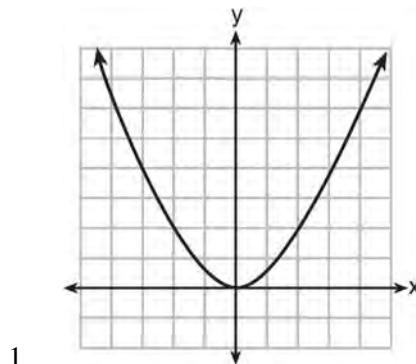

A.G.8: SOLVING QUADRATICS BY GRAPHING

- 512 Graph the equation $y = x^2 - 2x - 3$ on the accompanying set of axes. Using the graph, determine the roots of the equation $x^2 - 2x - 3 = 0$.

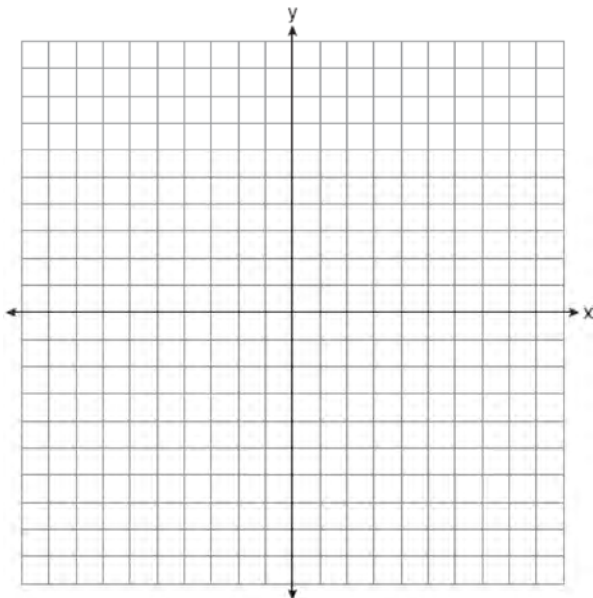

- 513 The equation $y = x^2 + 3x - 18$ is graphed on the set of axes below.

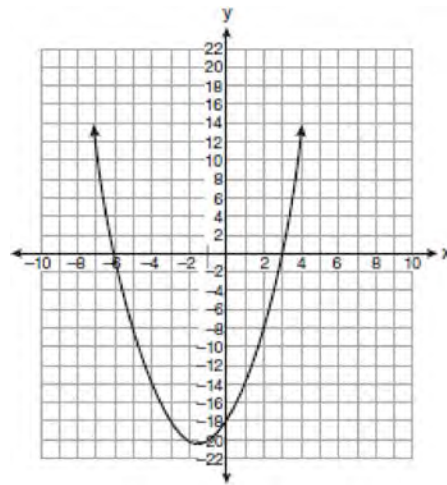

Based on this graph, what are the roots of the equation $x^2 + 3x - 18 = 0$?

- 1 -3 and 6
- 2 0 and -18
- 3 3 and -6
- 4 3 and -18

- 514 The equation $y = -x^2 - 2x + 8$ is graphed on the set of axes below.

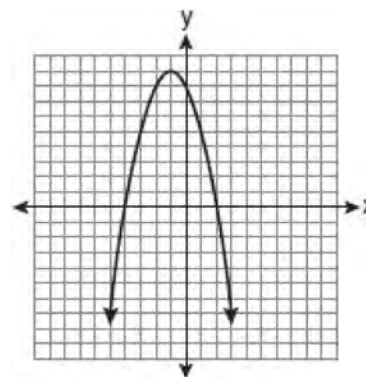

Based on this graph, what are the roots of the equation $-x^2 - 2x + 8 = 0$?

- 1 8 and 0
- 2 2 and -4
- 3 9 and -1
- 4 4 and -2

- 515 A student correctly graphed the parabola shown below to solve a given quadratic equation.

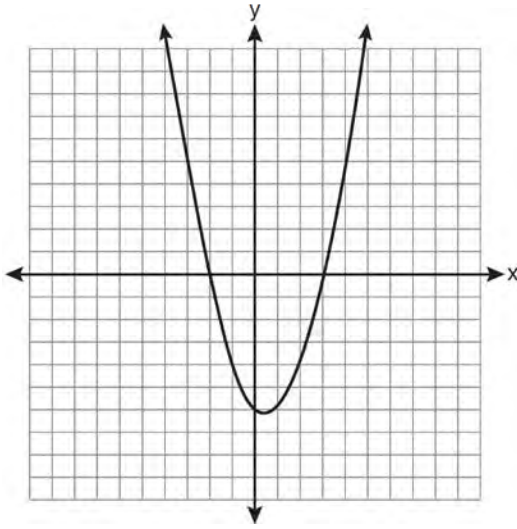

What are the roots of the quadratic equation associated with this graph?

- 1 -6 and 3
- 2 -6 and 0
- 3 -3 and 2
- 4 -2 and 3

- 516 On the set of axes below, graph the equation $y = x^2 + 2x - 8$. Using the graph, determine and state the roots of the equation $x^2 + 2x - 8 = 0$.

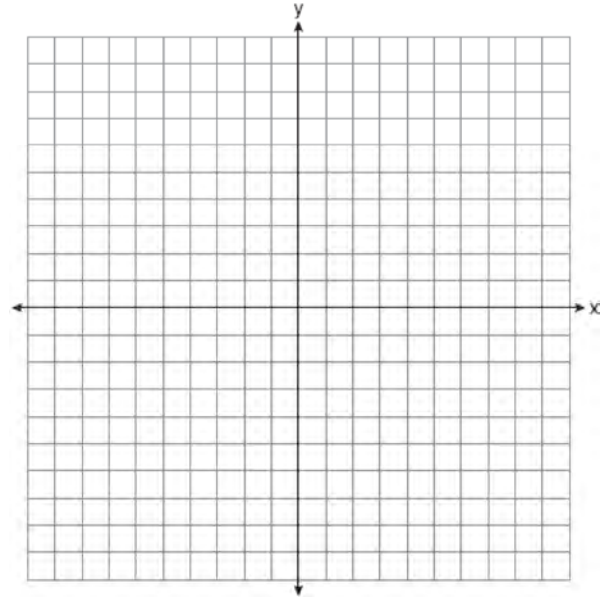

- 517 The roots of a quadratic equation can be found using the graph below.

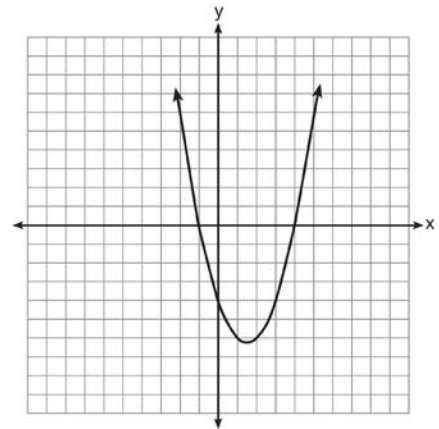

What are the roots of this equation?

- 1 -4, only
- 2 -4 and -1
- 3 -1 and 4
- 4 -4, -1, and 4

- 518 The equation $y = ax^2 + bx + c$ is graphed on the set of axes below.

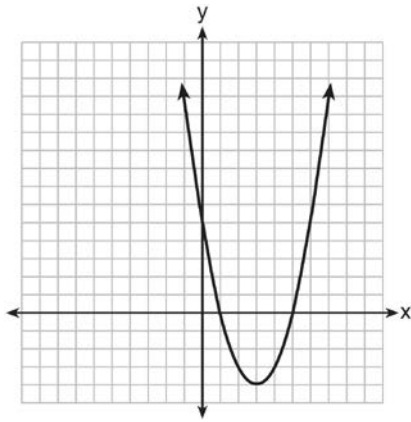

Based on the graph, what are the roots of the equation $ax^2 + bx + c = 0$?

- 1 0 and 5
 - 2 1 and 0
 - 3 1 and 5
 - 4 3 and -4
- 519 The graph of $f(x)$ is shown below.

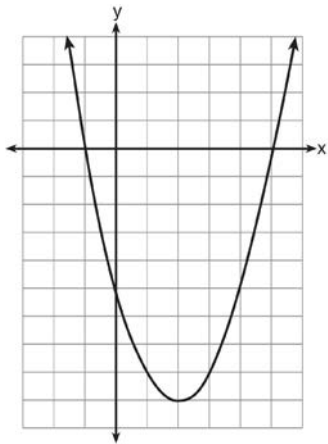

Based on this graph, what are the roots of the equation $f(x) = 0$?

- 1 1 and -5
- 2 -1 and 5
- 3 2 and -9
- 4 -1 and -5 and 5

- 520 On the set of axes below, graph $y = 2x^2 - 4x - 6$. State the roots of $0 = 2x^2 - 4x - 6$.

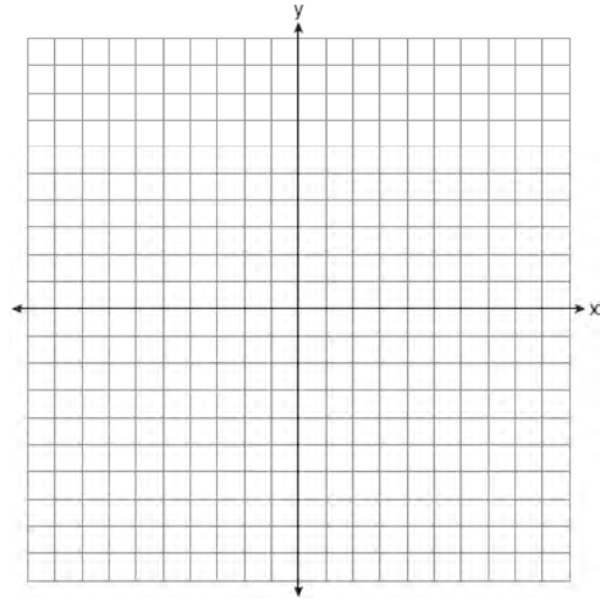

A.A.8: QUADRATIC FUNCTIONS

- 521 The equation $P = 0.0089t^2 + 1.1149t + 78.4491$ models the United States population, P , in millions since 1900. If t represents the number of years after 1900, then what is the estimated population in 2025 to the nearest tenth of a million?
- 1 217.8
 - 2 219.0
 - 3 343.9
 - 4 356.9
- 522 A model rocket is launched into the air from ground level. The height, in feet, is modeled by $p(x) = -16x^2 + 32x$, where x is the number of elapsed seconds. What is the total number of seconds the model rocket will be in the air?
- 1 1
 - 2 2
 - 3 0
 - 4 16

A.A.8: WRITING QUADRATICS

523 Find three consecutive positive even integers such that the product of the second and third integers is twenty more than ten times the first integer. [Only an algebraic solution can receive full credit.]

524 When 36 is subtracted from the square of a number, the result is five times the number. What is the positive solution?

- 1 9
- 2 6
- 3 3
- 4 4

525 Byron is 3 years older than Doug. The product of their ages is 40. How old is Doug?

- 1 10
- 2 8
- 3 5
- 4 4

526 Noj is 5 years older than Jacob. The product of their ages is 84. How old is Noj?

- 1 6
- 2 7
- 3 12
- 4 14

527 The square of a positive number is 24 more than 5 times the number. What is the value of the number?

- 1 6
- 2 8
- 3 3
- 4 4

A.A.8: GEOMETRIC APPLICATIONS OF QUADRATICS

528 A contractor needs 54 square feet of brick to construct a rectangular walkway. The length of the walkway is 15 feet more than the width. Write an equation that could be used to determine the dimensions of the walkway. Solve this equation to find the length and width, in feet, of the walkway.

529 A rectangle has an area of 24 square units. The width is 5 units less than the length. What is the length, in units, of the rectangle?

- 1 6
- 2 8
- 3 3
- 4 19

530 The length of a rectangle is 3 inches more than its width. The area of the rectangle is 40 square inches. What is the length, in inches, of the rectangle?

- 1 5
- 2 8
- 3 8.5
- 4 11.5

A.G.10: IDENTIFYING THE VERTEX OF A QUADRATIC GIVEN GRAPH

531 What are the vertex and the axis of symmetry of the parabola shown in the diagram below?

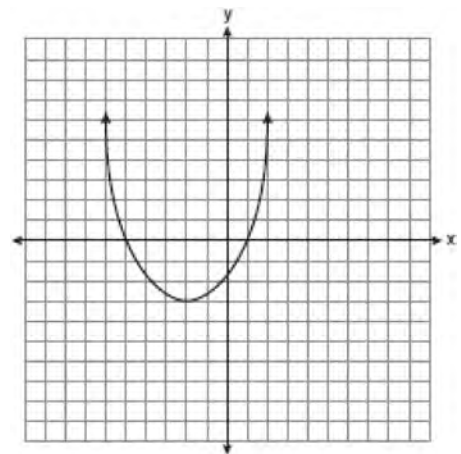

- 1 The vertex is $(-2, -3)$, and the axis of symmetry is $x = -2$.
- 2 The vertex is $(-2, -3)$, and the axis of symmetry is $y = -2$.
- 3 The vertex is $(-3, -2)$, and the axis of symmetry is $y = -2$.
- 4 The vertex is $(-3, -2)$, and the axis of symmetry is $x = -2$.

- 532 A swim team member performs a dive from a 14-foot-high springboard. The parabola below shows the path of her dive.

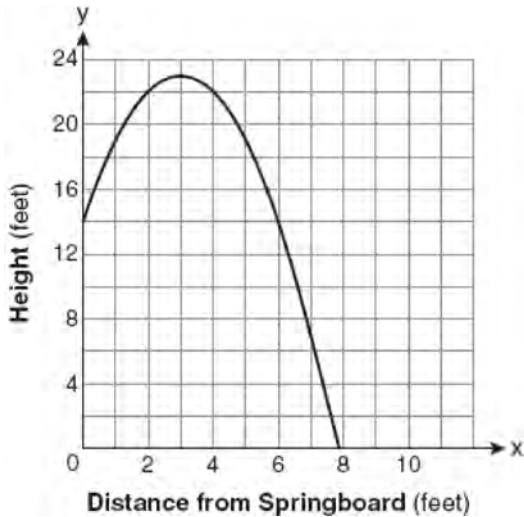

Which equation represents the axis of symmetry?

- 1 $x = 3$
 - 2 $y = 3$
 - 3 $x = 23$
 - 4 $y = 23$
- 533 Which equation represents the axis of symmetry of the graph of the parabola below?

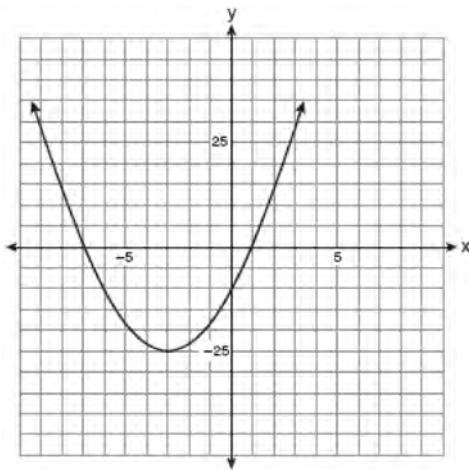

- 1 $y = -3$
- 2 $x = -3$
- 3 $y = -25$
- 4 $x = -25$

- 534 What is the equation of the axis of symmetry of the parabola shown in the diagram below?

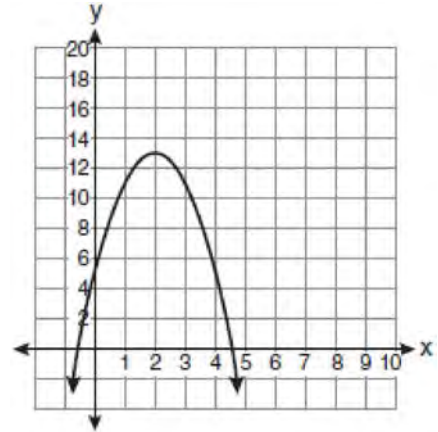

- 1 $x = -0.5$
- 2 $x = 2$
- 3 $x = 4.5$
- 4 $x = 13$

- 535 What are the vertex and axis of symmetry of the parabola shown in the diagram below?

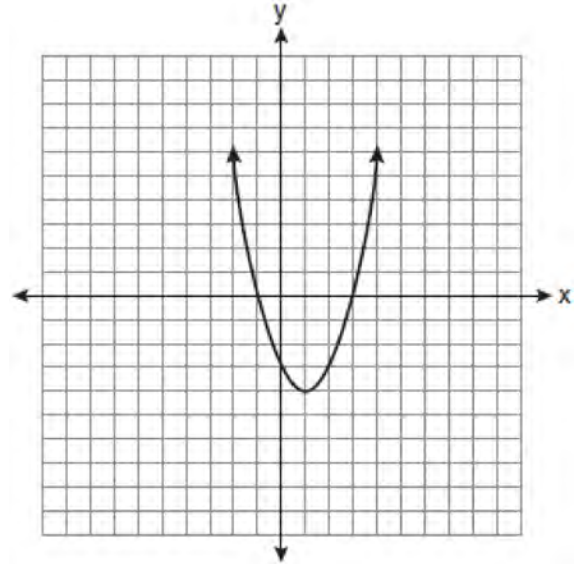

- 1 vertex: $(1, -4)$; axis of symmetry: $x = 1$
- 2 vertex: $(1, -4)$; axis of symmetry: $x = -4$
- 3 vertex: $(-4, 1)$; axis of symmetry: $x = 1$
- 4 vertex: $(-4, 1)$; axis of symmetry: $x = -4$

536 State the equation of the axis of symmetry and the coordinates of the vertex of the parabola graphed below.

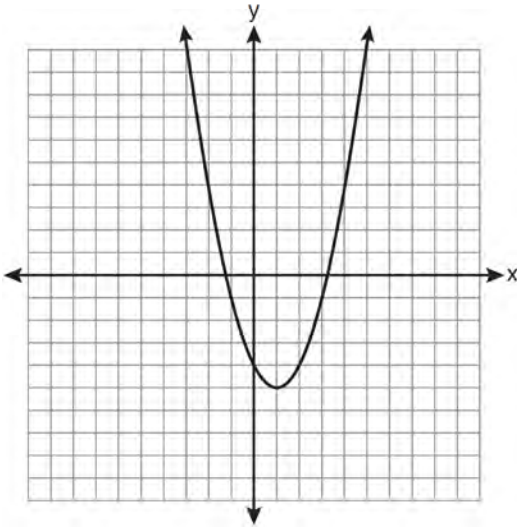

537 What are the vertex and the axis of symmetry of the parabola shown in the graph below?

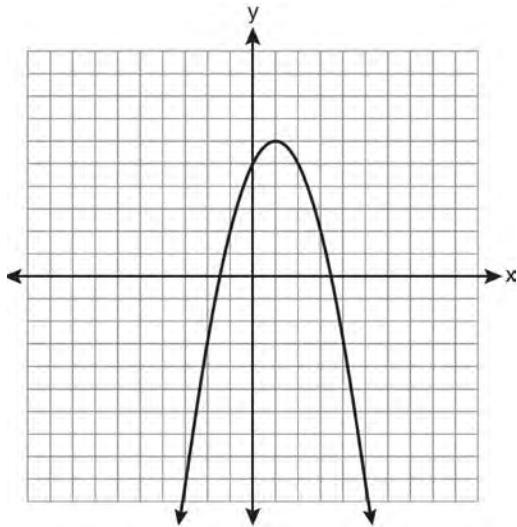

- 1 vertex: (1, 6); axis of symmetry: $y = 1$
- 2 vertex: (1, 6); axis of symmetry: $x = 1$
- 3 vertex: (6, 1); axis of symmetry: $y = 1$
- 4 vertex: (6, 1); axis of symmetry: $x = 1$

538 What are the coordinates of the vertex and the equation of the axis of symmetry of the parabola shown in the graph below?

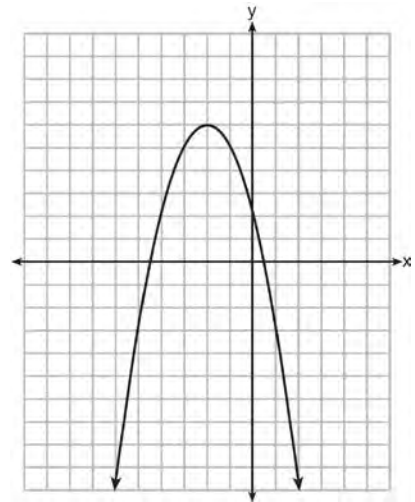

- 1 (0, 2) and $y = 2$
- 2 (0, 2) and $x = 2$
- 3 (-2, 6) and $y = -2$
- 4 (-2, 6) and $x = -2$

539 Which parabola has an axis of symmetry of $x = 1$?

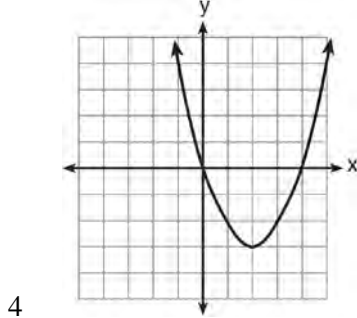
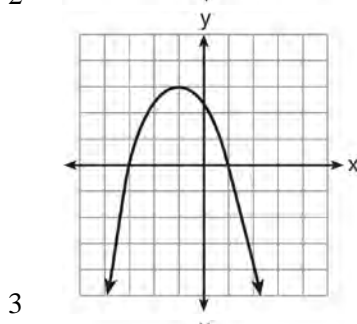
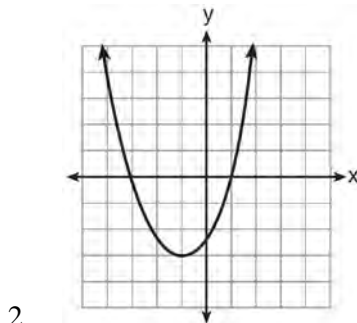
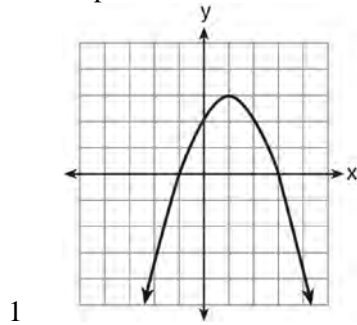

540 The graph below represents the parabolic path of a ball kicked by a young child. What are the vertex and the axis of symmetry for the parabola?

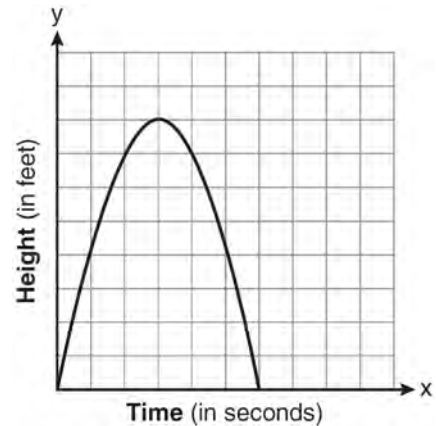

- 1 vertex: $(3, 8)$; axis of symmetry: $x = 3$
- 2 vertex: $(3, 8)$; axis of symmetry: $y = 3$
- 3 vertex: $(8, 3)$; axis of symmetry: $x = 3$
- 4 vertex: $(8, 3)$; axis of symmetry: $y = 3$

A.A.41: IDENTIFYING THE VERTEX OF A QUADRATIC GIVEN EQUATION

541 What are the vertex and axis of symmetry of the parabola $y = x^2 - 16x + 63$?

- 1 vertex: $(8, -1)$; axis of symmetry: $x = 8$
- 2 vertex: $(8, 1)$; axis of symmetry: $x = 8$
- 3 vertex: $(-8, -1)$; axis of symmetry: $x = -8$
- 4 vertex: $(-8, 1)$; axis of symmetry: $x = -8$

542 Find algebraically the equation of the axis of symmetry and the coordinates of the vertex of the parabola whose equation is $y = -2x^2 - 8x + 3$.

543 The height, y , of a ball tossed into the air can be represented by the equation $y = -x^2 + 10x + 3$, where x is the elapsed time. What is the equation of the axis of symmetry of this parabola?

- 1 $y = 5$
- 2 $y = -5$
- 3 $x = 5$
- 4 $x = -5$

- 544 What is an equation of the axis of symmetry of the parabola represented by $y = -x^2 + 6x - 4$?
- 1 $x = 3$
 - 2 $y = 3$
 - 3 $x = 6$
 - 4 $y = 6$
- 545 The equation of the axis of symmetry of the graph of $y = 2x^2 - 3x + 7$ is
- 1 $x = \frac{3}{4}$
 - 2 $y = \frac{3}{4}$
 - 3 $x = \frac{3}{2}$
 - 4 $y = \frac{3}{2}$
- 546 What is the vertex of the parabola represented by the equation $y = -2x^2 + 24x - 100$?
- 1 $x = -6$
 - 2 $x = 6$
 - 3 $(6, -28)$
 - 4 $(-6, -316)$
- 547 The vertex of the parabola $y = x^2 + 8x + 10$ lies in Quadrant
- 1 I
 - 2 II
 - 3 III
 - 4 IV
- 548 What is the vertex of the graph of the equation $y = 3x^2 + 6x + 1$?
- 1 $(-1, -2)$
 - 2 $(-1, 10)$
 - 3 $(1, -2)$
 - 4 $(1, 10)$
- 549 Which equation represents the axis of symmetry of the graph of the equation $y = x^2 + 4x - 5$?
- 1 $x = -2$
 - 2 $x = 4$
 - 3 $y = -2$
 - 4 $y = 4$
- 550 Find algebraically the equation of the axis of symmetry and the vertex of the parabola represented by the equation $y = -x^2 - 2x + 1$.
- A.A.10: SOLVING LINEAR SYSTEMS
- 551 The equations $5x + 2y = 48$ and $3x + 2y = 32$ represent the money collected from school concert ticket sales during two class periods. If x represents the cost for each adult ticket and y represents the cost for each student ticket, what is the cost for each adult ticket?
- 1 \$20
 - 2 \$10
 - 3 \$8
 - 4 \$4
- 552 Solve the following system of equations algebraically:
- $$3x + 2y = 4$$
- $$4x + 3y = 7$$
- [Only an algebraic solution can receive full credit.]
- 553 What is the value of the y -coordinate of the solution to the system of equations $x + 2y = 9$ and $x - y = 3$?
- 1 6
 - 2 2
 - 3 3
 - 4 5

Integrated Algebra Regents Exam Questions by Performance Indicator: Topic

www.jmap.org

554 What is the value of the y -coordinate of the solution to the system of equations $x - 2y = 1$ and $x + 4y = 7$?

- 1 1
- 2 -1
- 3 3
- 4 4

555 What is the solution of the system of equations $c + 3d = 8$ and $c = 4d - 6$?

- 1 $c = -14, d = -2$
- 2 $c = -2, d = 2$
- 3 $c = 2, d = 2$
- 4 $c = 14, d = -2$

556 What is the value of the y -coordinate of the solution to the system of equations $2x + y = 8$ and $x - 3y = -3$?

- 1 -2
- 2 2
- 3 3
- 4 -3

557 What is the solution of the system of equations $2x - 5y = 11$ and $-2x + 3y = -9$?

- 1 $(-3, -1)$
- 2 $(-1, 3)$
- 3 $(3, -1)$
- 4 $(3, 1)$

558 Solve the following system of equations algebraically for y :

$$2x + 2y = 9$$

$$2x - y = 3$$

559 Using the substitution method, Ken solves the following system of equations algebraically.

$$2x - y = 5$$

$$3x + 2y = -3$$

Which equivalent equation could Ken use?

- 1 $3x + 2(2x - 5) = -3$
- 2 $3x + 2(5 - 2x) = -3$
- 3 $3\left(y + \frac{5}{2}\right) + 2y = -3$
- 4 $3\left(\frac{5}{2} - y\right) + 2y = -3$

560 What is the solution of the system of equations below?

$$2x + 3y = 7$$

$$x + y = 3$$

- 1 $(1, 2)$
- 2 $(2, 1)$
- 3 $(4, -1)$
- 4 $(4, 1)$

561 What is the value of x in the solution of the system of equations $3x + 2y = 12$ and $5x - 2y = 4$?

- 1 8
- 2 2
- 3 3
- 4 4

562 The equations $6x + 5y = 300$ and $3x + 7y = 285$ represent the money collected from selling gift baskets in a school fundraising event. If x represents the cost for each snack gift basket and y represents the cost for each chocolate gift basket, what is the cost for each chocolate gift basket?

- 1 \$20
- 2 \$25
- 3 \$30
- 4 \$54

563 What is the solution of the following system of equations? $2a + 3b = 12$

$$a = \frac{1}{2}b - 6$$

- 1 $a = -6$ and $b = 0$
- 2 $a = -4.5$ and $b = 3$
- 3 $a = -3$ and $b = 6$
- 4 $a = 24$ and $b = 6$

A.G.7: SOLVING LINEAR SYSTEMS

564 On the grid below, solve the system of equations graphically for x and y .

$$4x - 2y = 10$$

$$y = -2x - 1$$

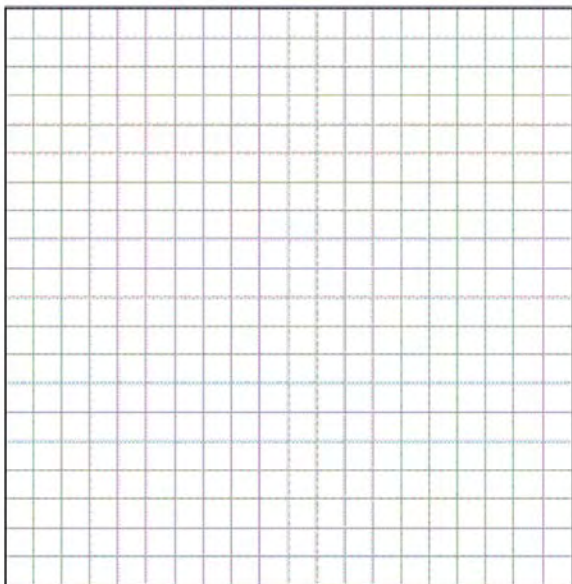

565 On the set of axes below, solve the following system of equations graphically. State the coordinates of the solution.

$$y = 4x - 1$$

$$2x + y = 5$$

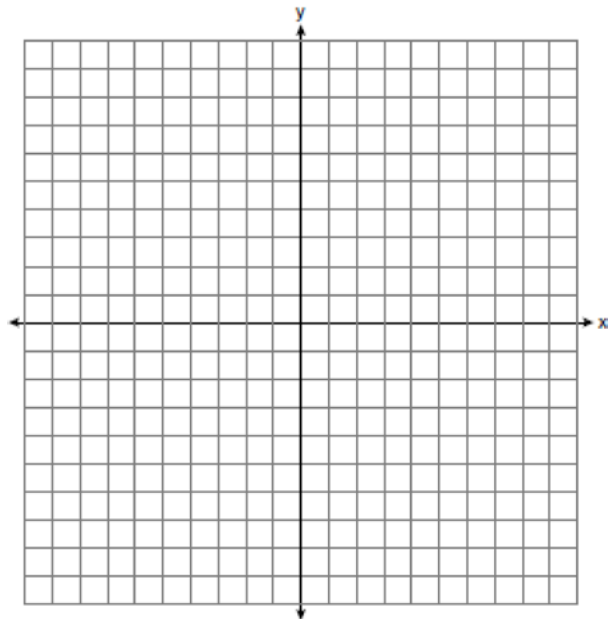

566 A system of equations is graphed on the set of axes below.

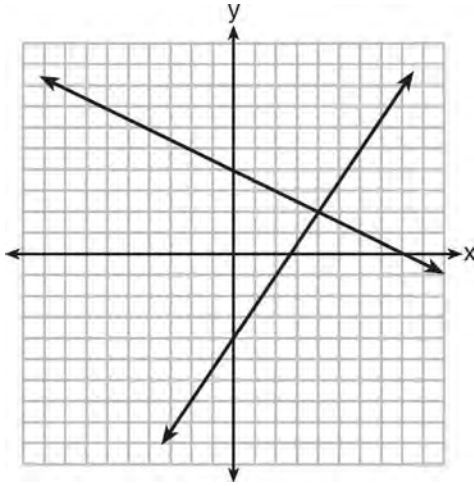

The solution of this system is

- 1 (0, 4)
- 2 (2, 4)
- 3 (4, 2)
- 4 (8, 0)

567 What is the solution of the system of equations shown in the graph below?

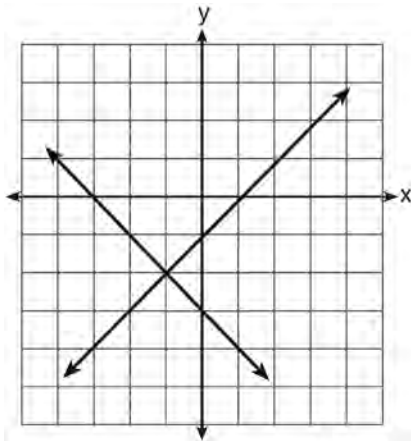

- 1 (1, 0) and (-3, 0)
- 2 (0, -3) and (0, -1)
- 3 (-1, -2)
- 4 (-2, -1)

A.A.7: WRITING LINEAR SYSTEMS

568 Jack bought 3 slices of cheese pizza and 4 slices of mushroom pizza for a total cost of \$12.50. Grace bought 3 slices of cheese pizza and 2 slices of mushroom pizza for a total cost of \$8.50. What is the cost of one slice of mushroom pizza?

- 1 \$1.50
- 2 \$2.00
- 3 \$3.00
- 4 \$3.50

569 Pam is playing with red and black marbles. The number of red marbles she has is three more than twice the number of black marbles she has. She has 42 marbles in all. How many red marbles does Pam have?

- 1 13
- 2 15
- 3 29
- 4 33

570 Sam and Odel have been selling frozen pizzas for a class fundraiser. Sam has sold half as many pizzas as Odel. Together they have sold a total of 126 pizzas. How many pizzas did Sam sell?

- 1 21
- 2 42
- 3 63
- 4 84

571 The cost of 3 markers and 2 pencils is \$1.80. The cost of 4 markers and 6 pencils is \$2.90. What is the cost of *each* item? Include appropriate units in your answer.

572 The sum of two numbers is 47, and their difference is 15. What is the larger number?

- 1 16
- 2 31
- 3 32
- 4 36

Integrated Algebra Regents Exam Questions by Performance Indicator: Topic

www.jmap.org

- 573 At Genesee High School, the sophomore class has 60 more students than the freshman class. The junior class has 50 fewer students than twice the students in the freshman class. The senior class is three times as large as the freshman class. If there are a total of 1,424 students at Genesee High School, how many students are in the freshman class?
- 1 202
 - 2 205
 - 3 235
 - 4 236
- 574 Julia went to the movies and bought one jumbo popcorn and two chocolate chip cookies for \$5.00. Marvin went to the same movie and bought one jumbo popcorn and four chocolate chip cookies for \$6.00. How much does one chocolate chip cookie cost?
- 1 \$0.50
 - 2 \$0.75
 - 3 \$1.00
 - 4 \$2.00
- 575 Josh and Mae work at a concession stand. They each earn \$8 per hour. Josh worked three hours more than Mae. If Josh and Mae earned a total of \$120, how many hours did Josh work?
- 1 6
 - 2 9
 - 3 12
 - 4 15
- 576 Michael is 25 years younger than his father. The sum of their ages is 53. What is Michael's age?
- 1 14
 - 2 25
 - 3 28
 - 4 39
- 577 Ben has four more than twice as many CDs as Jake. If they have a total of 31 CDs, how many CDs does Jake have?
- 1 9
 - 2 13
 - 3 14
 - 4 22
- 578 The total score in a football game was 72 points. The winning team scored 12 points more than the losing team. How many points did the winning team score?
- 1 30
 - 2 42
 - 3 54
 - 4 60
- 579 The cost of three notebooks and four pencils is \$8.50. The cost of five notebooks and eight pencils is \$14.50. Determine the cost of one notebook and the cost of one pencil. [Only an algebraic solution can receive full credit.]
- 580 The difference between two numbers is 28. The larger number is 8 less than twice the smaller number. Find *both* numbers. [Only an algebraic solution can receive full credit.]
- 581 During its first week of business, a market sold a total of 108 apples and oranges. The second week, five times the number of apples and three times the number of oranges were sold. A total of 452 apples and oranges were sold during the second week. Determine how many apples and how many oranges were sold the first week. [Only an algebraic solution can receive full credit.]
- 582 A DVD costs twice as much as a music CD. Jack buys 2 DVDs and 2 CDs and spends \$45. Determine how much one CD costs, in dollars. [Only an algebraic solution can receive full credit.]

583 The local deli charges a fee for delivery. On Monday, they delivered two dozen bagels to an office at a total cost of \$8. On Tuesday, three dozen bagels were delivered at a total cost of \$11. Which system of equations could be used to find the cost of a dozen bagels, b , if the delivery fee is f ?

- 1 $b + 2f = 8$
 $b + 3f = 11$
- 2 $2b + f = 8$
 $b + 3f = 11$
- 3 $b + 2f = 8$
 $3b + f = 11$
- 4 $2b + f = 8$
 $3b + f = 11$

A.A.40: SYSTEMS OF LINEAR INEQUALITIES

584 Which ordered pair is in the solution set of the following system of inequalities?

$$y < \frac{1}{2}x + 4$$

$$y \geq -x + 1$$

- 1 $(-5, 3)$
- 2 $(0, 4)$
- 3 $(3, -5)$
- 4 $(4, 0)$

585 Which ordered pair is in the solution set of the following system of linear inequalities?

$$y < 2x + 2$$

$$y \geq -x - 1$$

- 1 $(0, 3)$
- 2 $(2, 0)$
- 3 $(-1, 0)$
- 4 $(-1, -4)$

586 Which ordered pair is in the solution set of the system of linear inequalities graphed below?

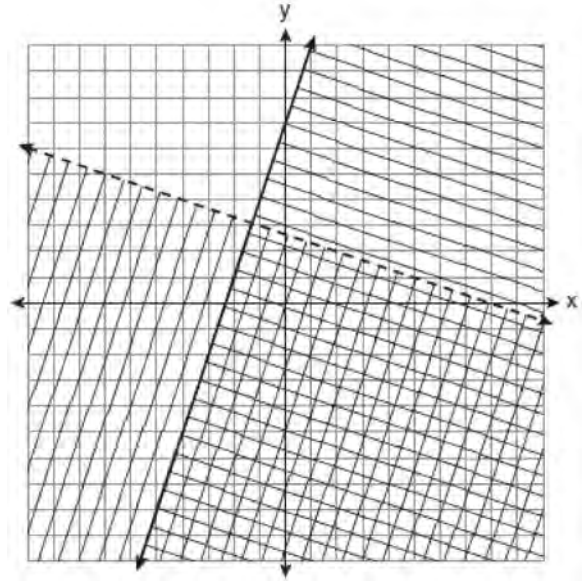

- 1 $(1, -4)$
- 2 $(-5, 7)$
- 3 $(5, 3)$
- 4 $(-7, -2)$

587 Which ordered pair is in the solution set of the system of inequalities shown in the graph below?

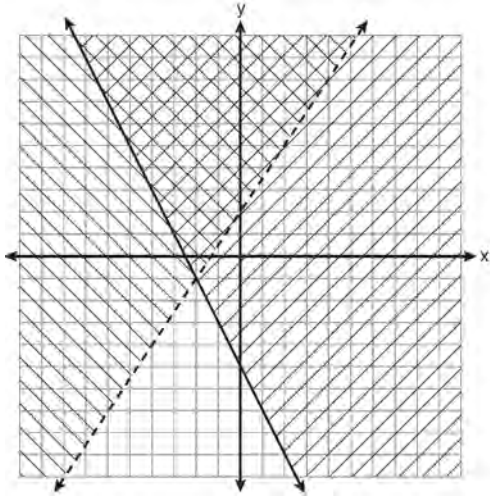

- 1 $(-2, -1)$
- 2 $(-2, 2)$
- 3 $(-2, -4)$
- 4 $(2, -2)$

588 Which coordinates represent a point in the solution set of the system of inequalities shown below?

$$y \leq \frac{1}{2}x + 13$$

$$4x + 2y > 3$$

- 1 $(-4, 1)$
- 2 $(-2, 2)$
- 3 $(1, -4)$
- 4 $(2, -2)$

589 Which ordered pair is in the solution set of the system of inequalities $y \leq 3x + 1$ and $x - y > 1$?

- 1 $(-1, -2)$
- 2 $(2, -1)$
- 3 $(1, 2)$
- 4 $(-1, 2)$

A.G.7: SYSTEMS OF LINEAR INEQUALITIES

590 On the set of axes below, graph the following system of inequalities and state the coordinates of a point in the solution set.

$$2x - y \geq 6$$

$$x > 2$$

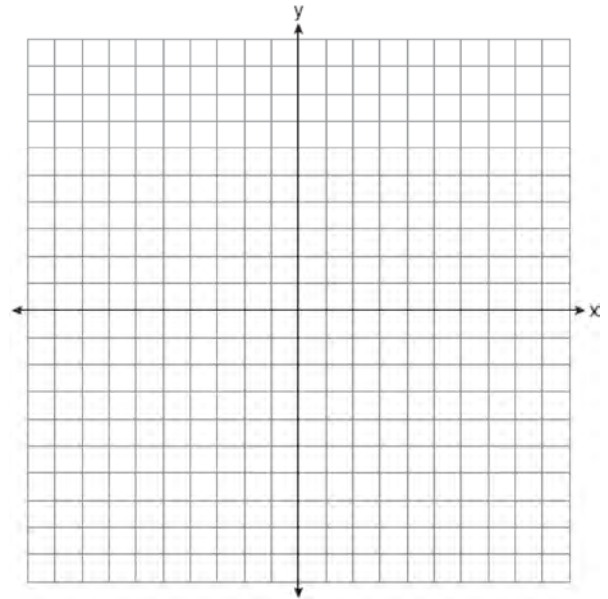

- 591 On the set of axes below, solve the following system of inequalities graphically.

$$y < 2x + 1$$

$$y \geq -\frac{1}{3}x + 4$$

State the coordinates of a point in the solution set.

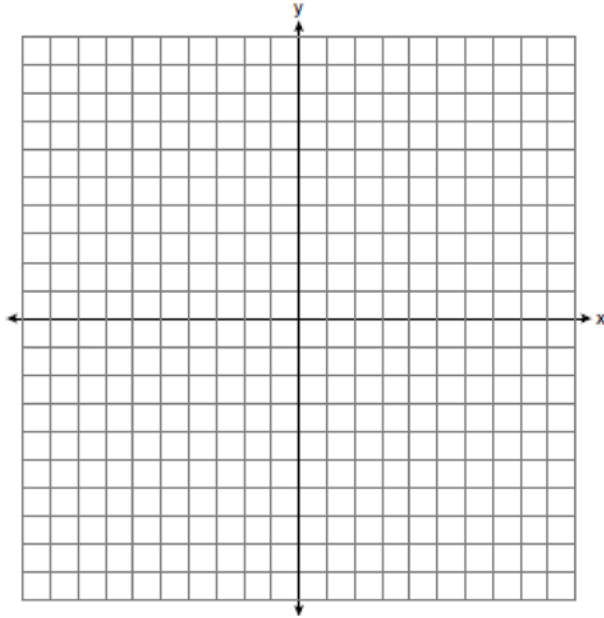

- 592 Graph the following systems of inequalities on the set of axes shown below and label the solution set S :

$$y > -x + 2$$

$$y \leq \frac{2}{3}x + 5$$

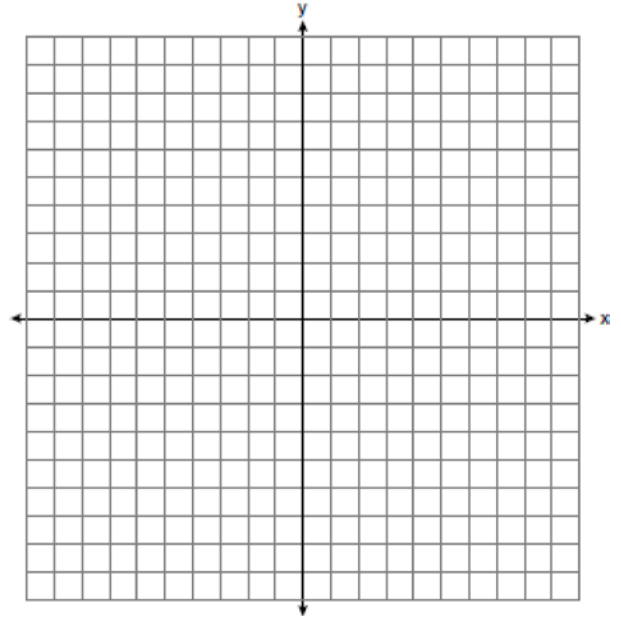

- 593 Solve the following system of inequalities graphically on the set of axes below.

$$3x + y < 7$$

$$y \geq \frac{2}{3}x - 4$$

State the coordinates of a point in the solution set.

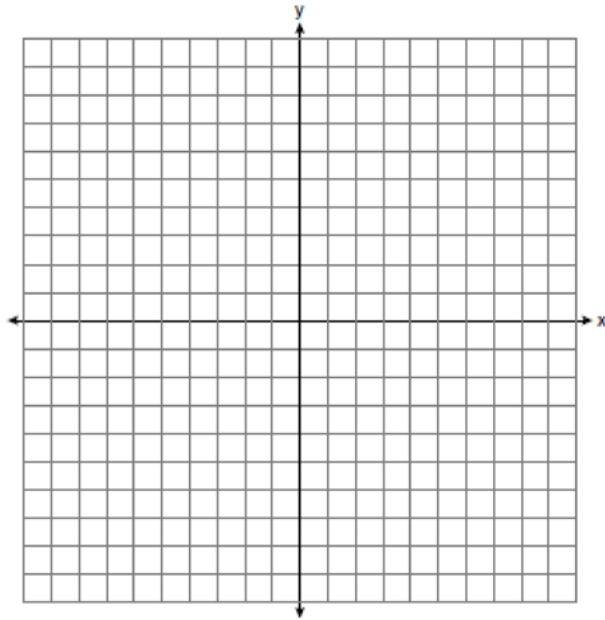

- 594 On the set of axes below, graph the following system of inequalities.

$$y + x \geq 3$$

$$5x - 2y > 10$$

State the coordinates of *one* point that satisfies $y + x \geq 3$, but does *not* satisfy $5x - 2y > 10$.

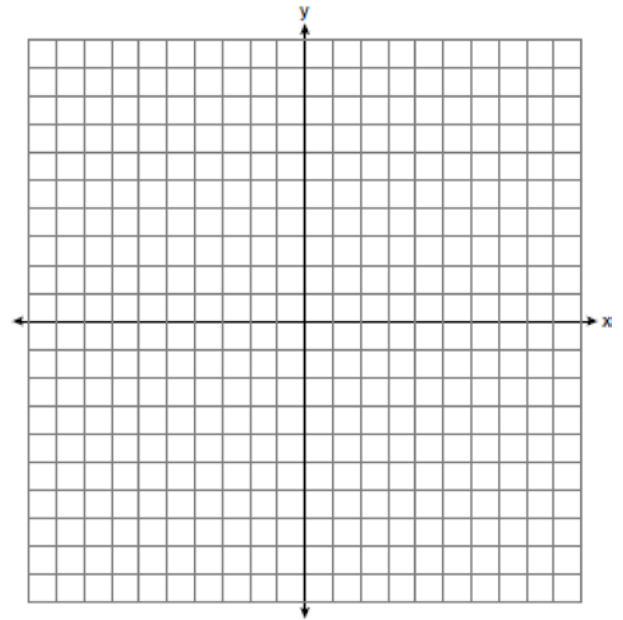

- 595 On the set of axes below, solve the following system of inequalities graphically. Label the solution set S .

$$2x + 3y < -3$$

$$y - 4x \geq 2$$

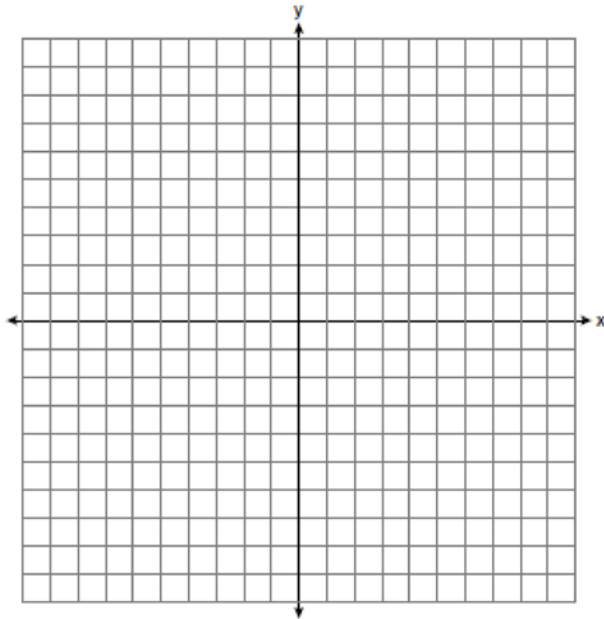

- 596 On the set of axes below, solve the following system of inequalities graphically.

$$y + 3 < 2x$$

$$-2y \leq 6x - 10$$

State the coordinates of a point in the solution set.

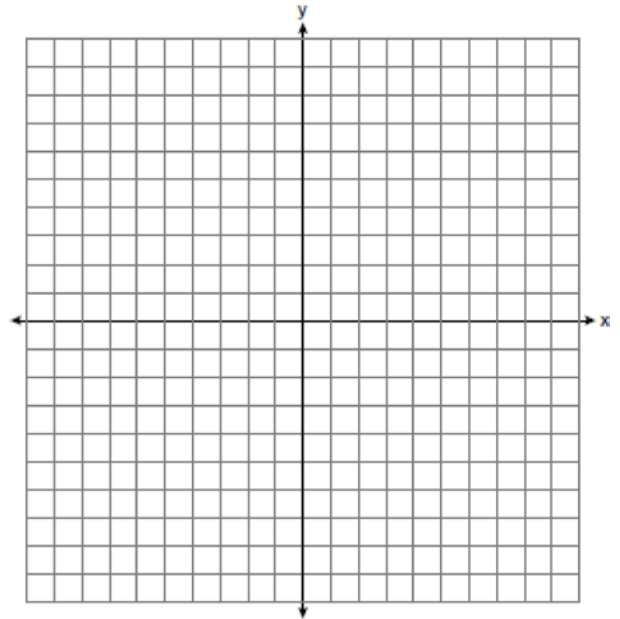

597 Graph $y < x$ and $x > 5$ on the axes below.

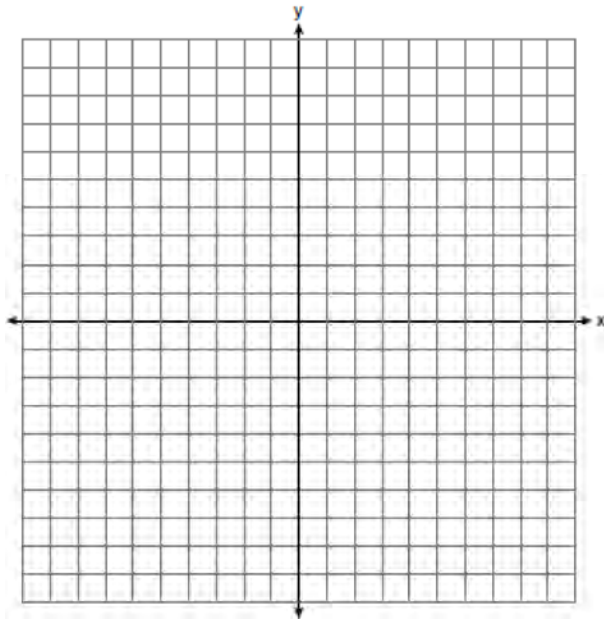

State the coordinates of a point in the solution set.

A.A.11: QUADRATIC-LINEAR SYSTEMS

598 Which ordered pair is a solution to the system of equations $y = x$ and $y = x^2 - 2$?

- 1 $(-2, -2)$
- 2 $(-1, 1)$
- 3 $(0, 0)$
- 4 $(2, 2)$

599 Which ordered pair is in the solution set of the system of equations $y = -x + 1$ and $y = x^2 + 5x + 6$?

- 1 $(-5, -1)$
- 2 $(-5, 6)$
- 3 $(5, -4)$
- 4 $(5, 2)$

600 Which ordered pair is a solution of the system of equations $y = x^2 - x - 20$ and $y = 3x - 15$?

- 1 $(-5, -30)$
- 2 $(-1, -18)$
- 3 $(0, 5)$
- 4 $(5, -1)$

601 Which ordered pair is a solution to the system of equations $y = x + 3$ and $y = x^2 - x$?

- 1 $(6, 9)$
- 2 $(3, 6)$
- 3 $(3, -1)$
- 4 $(2, 5)$

602 What is the solution set of the system of equations $x + y = 5$ and $y = x^2 - 25$?

- 1 $\{(0, 5), (11, -6)\}$
- 2 $\{(5, 0), (-6, 11)\}$
- 3 $\{(-5, 0), (6, 11)\}$
- 4 $\{(-5, 10), (6, -1)\}$

603 Solve the following system of equations algebraically for *all* values of x and y .

$$y = x^2 + 2x - 8$$

$$y = 2x + 1$$

604 Solve the following system of equations algebraically for all values of x and y .

$$y = x^2 + 2x - 8$$

$$y = 2x + 1$$

605 Solve the following system of equations algebraically: $y = x^2 - 6x + 9$

$$y = -9x + 19$$

606 Solve the following system of equations algebraically: $y = x^2 + 5x - 17$

$$y = x - 5$$

A.G.9: QUADRATIC-LINEAR SYSTEMS

607 Solve the following systems of equations graphically, on the set of axes below, and state the coordinates of the point(s) in the solution set.

$$y = x^2 - 6x + 5$$

$$2x + y = 5$$

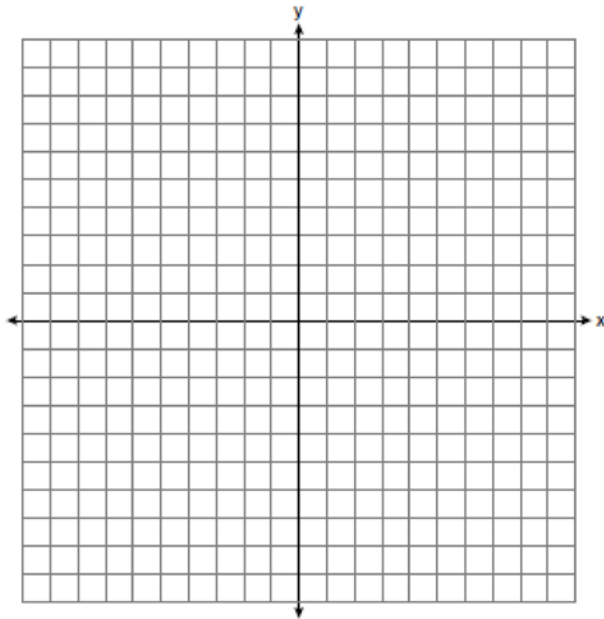

608 On the set of axes below, solve the following system of equations graphically and state the coordinates of all points in the solution set.

$$y = x^2 + 4x - 5$$

$$y = x - 1$$

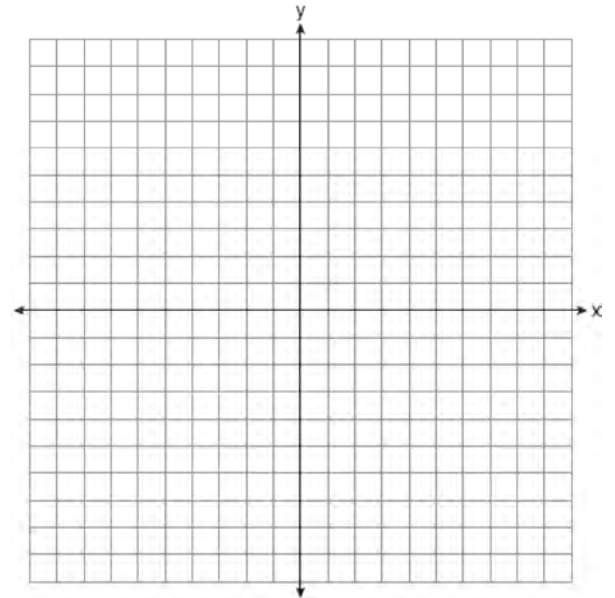

- 609 On the set of axes below, solve the following system of equations graphically for all values of x and y .

$$y = x^2 - 6x + 1$$

$$y + 2x = 6$$

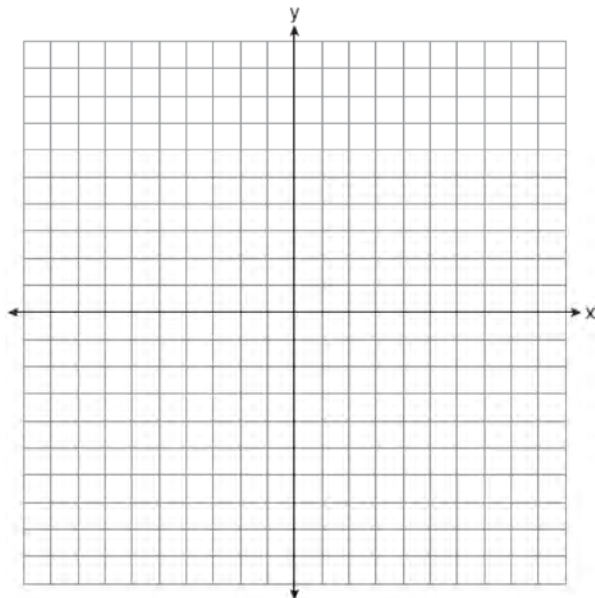

- 610 Which ordered pair is a solution of the system of equations shown in the graph below?

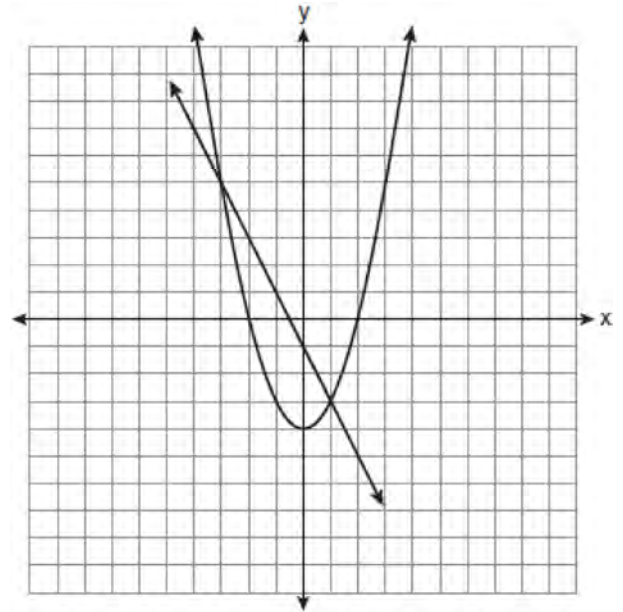

- 1 $(-3, 1)$
- 2 $(-3, 5)$
- 3 $(0, -1)$
- 4 $(0, -4)$

- 611 On the set of axes below, solve the following system of equations graphically for all values of x and y .

$$y = -x^2 - 4x + 12$$

$$y = -2x + 4$$

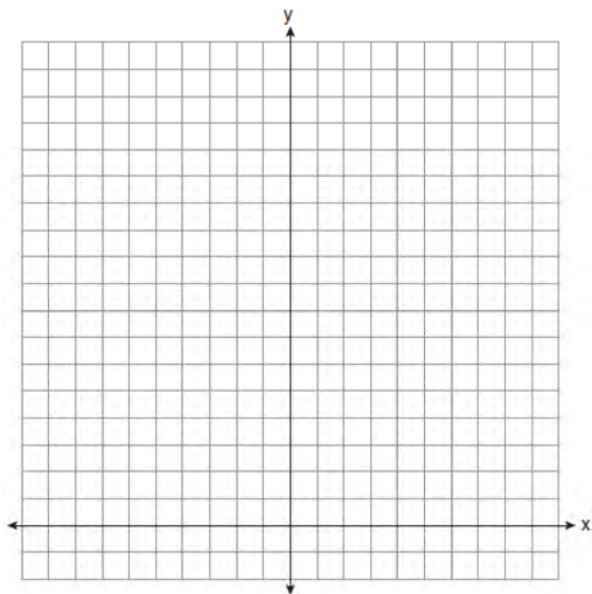

- 612 Which graph can be used to find the solution of the following system of equations?

$$y = x^2 + 2x + 3$$

$$2y - 2x = 10$$

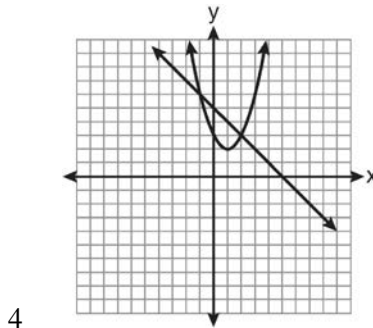
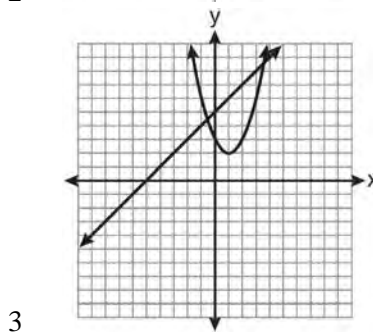
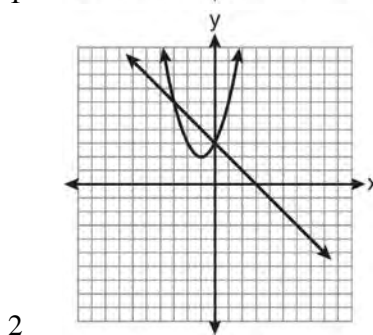
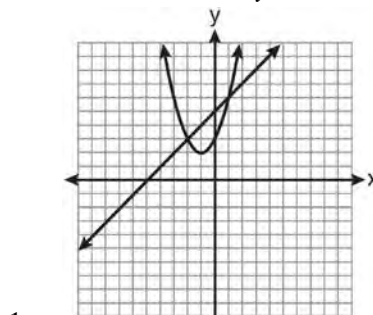

- 613 Which graph could be used to find the solution of the system of equations $y = 2x + 6$ and $y = x^2 + 4x + 3$?

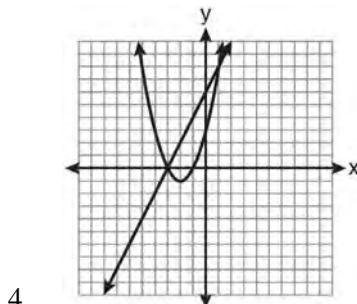
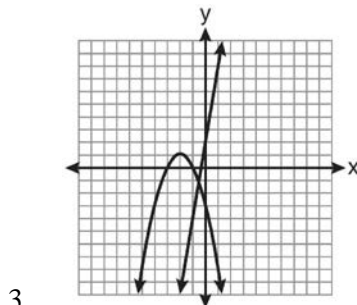
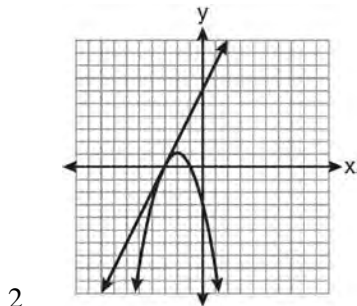
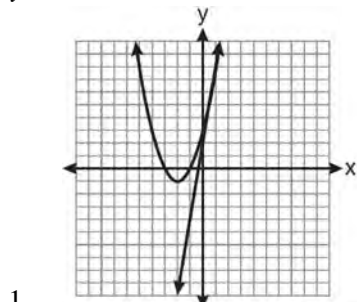

- 614 On the set of axes below, solve the following system of equations graphically and state the coordinates of *all* points in the solution set.

$$y = -x^2 + 6x - 3$$

$$x + y = 7$$

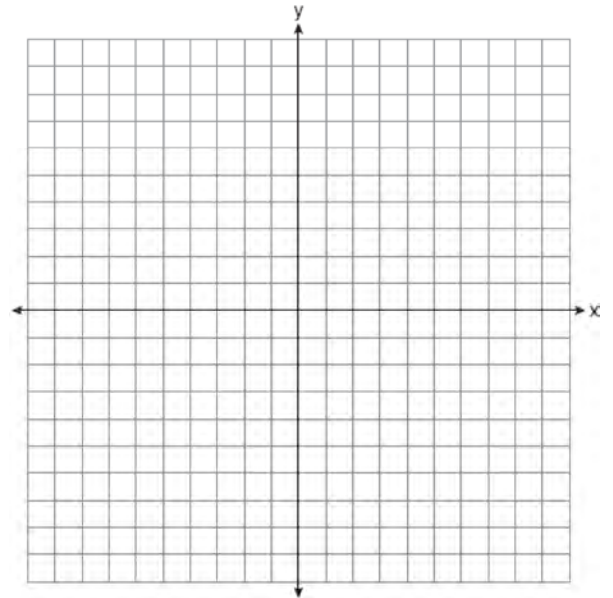

- 615 Two equations were graphed on the set of axes below.

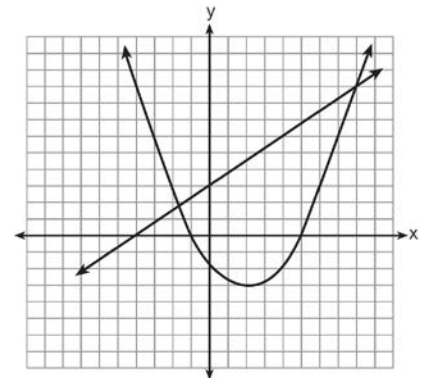

Which point is a solution of the system of equations shown on the graph?

- 1 (8, 9)
- 2 (5, 0)
- 3 (0, 3)
- 4 (2, -3)

- 616 On the set of axes below, graph the following system of equations.

$$y + 2x = x^2 + 4$$

$$y - x = 4$$

Using the graph, determine and state the coordinates of *all* points in the solution set for the system of equations.

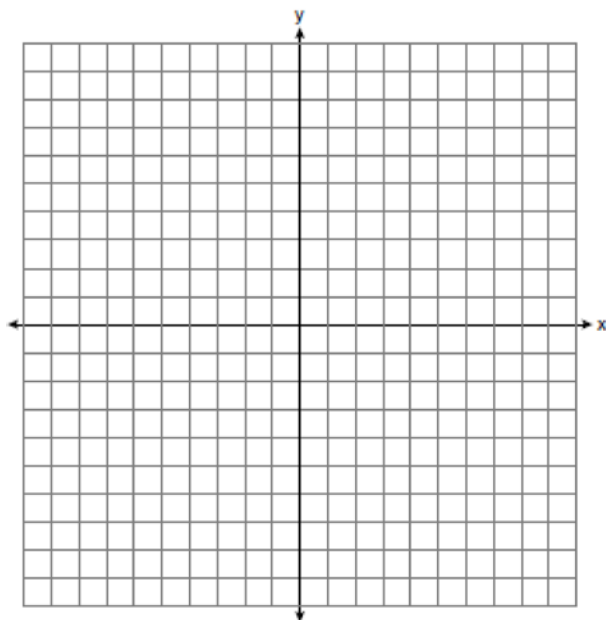

- 618 On the set of axes below, graph the following system of equations. Using the graph, determine and state *all* solutions of the system of equations.

$$y = -x^2 - 2x + 3$$

$$y + 1 = -2x$$

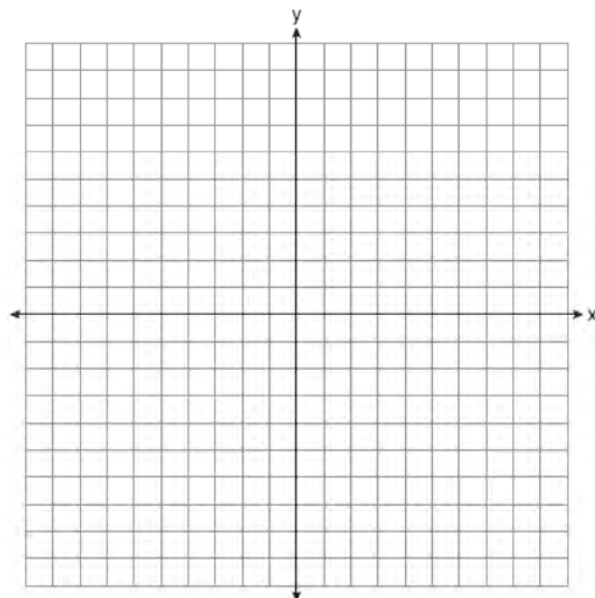

- 617 How many solutions are there for the following system of equations?

$$y = x^2 - 5x + 3$$

$$y = x - 6$$

- 1 1
- 2 2
- 3 3
- 4 0

- 619 On the set of axes below, solve the following system of equations graphically for all values of x and y . State the coordinates of all solutions.

$$y = x^2 + 4x - 5$$

$$y = 2x + 3$$

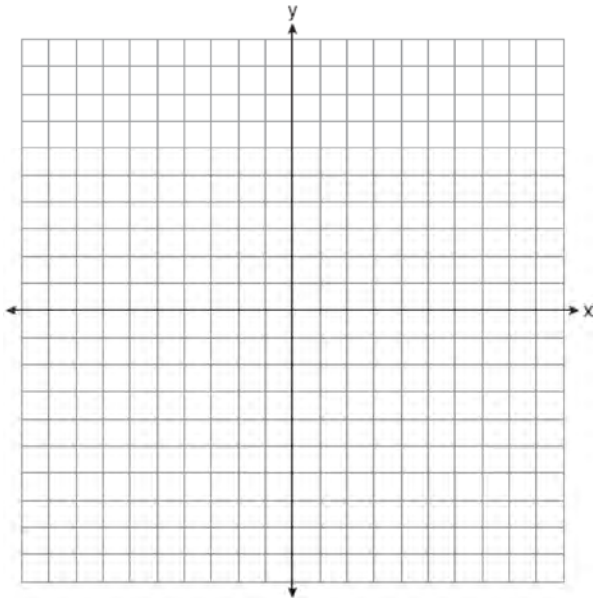

POWERS

A.A.13: ADDITION AND SUBTRACTION OF MONOMIALS

- 620 Which expression is equivalent to $-3x(x - 4) - 2x(x + 3)$?
- 1 $-x^2 - 1$
 - 2 $-x^2 + 18x$
 - 3 $-5x^2 - 6x$
 - 4 $-5x^2 + 6x$

A.A.13: ADDITION AND SUBTRACTION OF POLYNOMIALS

- 621 When $3g^2 - 4g + 2$ is subtracted from $7g^2 + 5g - 1$, the difference is
- 1 $-4g^2 - 9g + 3$
 - 2 $4g^2 + g + 1$
 - 3 $4g^2 + 9g - 3$
 - 4 $10g^2 + g + 1$
- 622 When $4x^2 + 7x - 5$ is subtracted from $9x^2 - 2x + 3$, the result is
- 1 $5x^2 + 5x - 2$
 - 2 $5x^2 - 9x + 8$
 - 3 $-5x^2 + 5x - 2$
 - 4 $-5x^2 + 9x - 8$
- 623 The sum of $4x^3 + 6x^2 + 2x - 3$ and $3x^3 + 3x^2 - 5x - 5$ is
- 1 $7x^3 + 3x^2 - 3x - 8$
 - 2 $7x^3 + 3x^2 + 7x + 2$
 - 3 $7x^3 + 9x^2 - 3x - 8$
 - 4 $7x^6 + 9x^4 - 3x^2 - 8$
- 624 What is the result when $2x^2 + 3xy - 6$ is subtracted from $x^2 - 7xy + 2$?
- 1 $-x^2 - 10xy + 8$
 - 2 $x^2 + 10xy - 8$
 - 3 $-x^2 - 4xy - 4$
 - 4 $x^2 - 4xy - 4$
- 625 When $5x + 4y$ is subtracted from $5x - 4y$, the difference is
- 1 0
 - 2 $10x$
 - 3 $8y$
 - 4 $-8y$

Integrated Algebra Regents Exam Questions by Performance Indicator: Topic

www.jmap.org

- 626 What is the sum of $-3x^2 - 7x + 9$ and $-5x^2 + 6x - 4$?
- 1 $-8x^2 - x + 5$
 - 2 $-8x^4 - x + 5$
 - 3 $-8x^2 - 13x + 13$
 - 4 $-8x^4 - 13x^2 + 13$
- 627 When $8x^2 + 3x + 2$ is subtracted from $9x^2 - 3x - 4$, the result is
- 1 $x^2 - 2$
 - 2 $17x^2 - 2$
 - 3 $-x^2 + 6x + 6$
 - 4 $x^2 - 6x - 6$
- 628 The sum of $3x^2 + 5x - 6$ and $-x^2 + 3x + 9$ is
- 1 $2x^2 + 8x - 15$
 - 2 $2x^2 + 8x + 3$
 - 3 $2x^4 + 8x^2 + 3$
 - 4 $4x^2 + 2x - 15$
- 629 When $2x^2 - 3x + 2$ is subtracted from $4x^2 - 5x + 2$, the result is
- 1 $2x^2 - 2x$
 - 2 $-2x^2 + 2x$
 - 3 $-2x^2 - 8x + 4$
 - 4 $2x^2 - 8x + 4$
- 630 The sum of $8n^2 - 3n + 10$ and $-3n^2 - 6n - 7$ is
- 1 $5n^2 - 9n + 3$
 - 2 $5n^2 - 3n - 17$
 - 3 $-11n^2 - 9n - 17$
 - 4 $-11n^2 - 3n + 3$
- 631 What is the result when $4x^2 - 17x + 36$ is subtracted from $2x^2 - 5x + 25$?
- 1 $6x^2 - 22x + 61$
 - 2 $2x^2 - 12x + 11$
 - 3 $-2x^2 - 22x + 61$
 - 4 $-2x^2 + 12x - 11$
- 632 When $6x^2 - 4x + 3$ is subtracted from $3x^2 - 2x + 3$, the result is
- 1 $3x^2 - 2x$
 - 2 $-3x^2 + 2x$
 - 3 $3x^2 - 6x + 6$
 - 4 $-3x^2 - 6x + 6$
- 633 What is the result when $6x^2 - 13x + 12$ is subtracted from $-3x^2 + 6x + 7$?
- 1 $3x^2 - 7x + 19$
 - 2 $9x^2 - 19x + 5$
 - 3 $9x^2 - 7x + 19$
 - 4 $-9x^2 + 19x - 5$

A.A.13: MULTIPLICATION OF POLYNOMIALS

- 634 What is the product of $-3x^2y$ and $(5xy^2 + xy)$?
- 1 $-15x^3y^3 - 3x^3y^2$
 - 2 $-15x^3y^3 - 3x^3y$
 - 3 $-15x^2y^2 - 3x^2y$
 - 4 $-15x^3y^3 + xy$
- 635 What is the product of $(3x + 2)$ and $(x - 7)$?
- 1 $3x^2 - 14$
 - 2 $3x^2 - 5x - 14$
 - 3 $3x^2 - 19x - 14$
 - 4 $3x^2 - 23x - 14$
- 636 The length of a rectangle is represented by $x^2 + 3x + 2$, and the width is represented by $4x$. Express the perimeter of the rectangle as a trinomial. Express the area of the rectangle as a trinomial.

A.A.14: DIVISION OF POLYNOMIALS

- 637 Which expression represents $\frac{12x^3 - 6x^2 + 2x}{2x}$ in simplest form?
- 1 $6x^2 - 3x$
 - 2 $10x^2 - 4x$
 - 3 $6x^2 - 3x + 1$
 - 4 $10x^2 - 4x + 1$
- 638 Express in simplest form: $\frac{45a^4b^3 - 90a^3b}{15a^2b}$
- 639 The quotient of $\frac{8x^5 - 2x^4 + 4x^3 - 6x^2}{2x^2}$ is
- 1 $16x^7 - 4x^6 + 8x^5 - 12x^4$
 - 2 $4x^7 - x^6 + 2x^5 - 3x^4$
 - 3 $4x^3 - x^2 + 2x - 3x$
 - 4 $4x^3 - x^2 + 2x - 3$
- 640 What is $24x^2y^6 - 16x^6y^2 + 4xy^2$ divided by $4xy^2$?
- 1 $6xy^4 - 4x^5$
 - 2 $6xy^4 - 4x^5 + 1$
 - 3 $6x^2y^3 - 4x^6y$
 - 4 $6x^2y^3 - 4x^6y + 1$
- 641 When $16x^3 - 12x^2 + 4x$ is divided by $4x$, the quotient is
- 1 $12x^2 - 8x$
 - 2 $12x^2 - 8x + 1$
 - 3 $4x^2 - 3x$
 - 4 $4x^2 - 3x + 1$

A.A.12: MULTIPLICATION OF POWERS

- 642 Which expression represents $(3x^2y^4)(4xy^2)$ in simplest form?
- 1 $12x^2y^8$
 - 2 $12x^2y^6$
 - 3 $12x^3y^8$
 - 4 $12x^3y^6$
- 643 Which expression is equivalent to $3^3 \cdot 3^4$?
- 1 9^{12}
 - 2 9^7
 - 3 3^{12}
 - 4 3^7
- 644 The product of $6x^3y^3$ and $2x^2y$ is
- 1 $3xy^2$
 - 2 $8x^5y^4$
 - 3 $12x^5y^4$
 - 4 $12x^6y^3$
- 645 What is the product of $3a^2b$ and $-2ab^3$?
- 1 a^2b^3
 - 2 a^3b^4
 - 3 $-6a^2b^3$
 - 4 $-6a^3b^4$

A.A.12: DIVISION OF POWERS

- 646 Which expression represents $\frac{(2x^3)(8x^5)}{4x^6}$ in simplest form?
- 1 x^2
 - 2 x^9
 - 3 $4x^2$
 - 4 $4x^9$

647 What is half of 2^6 ?

- 1 1^3
- 2 1^6
- 3 2^3
- 4 2^5

648 Simplify: $\frac{27k^5m^8}{(4k^3)(9m^2)}$

649 Which expression represents $\frac{27x^{18}y^5}{9x^6y}$ in simplest form?

- 1 $3x^{12}y^4$
- 2 $3x^3y^5$
- 3 $18x^{12}y^4$
- 4 $18x^3y^5$

650 Which expression represents $\frac{-14a^2c^8}{7a^3c^2}$ in simplest form?

- 1 $-2ac^4$
- 2 $-2ac^6$
- 3 $\frac{-2c^4}{a}$
- 4 $\frac{-2c^6}{a}$

651 The expression $\frac{12w^9y^3}{-3w^3y^3}$ is equivalent to

- 1 $-4w^6$
- 2 $-4w^3y$
- 3 $9w^6$
- 4 $9w^3y$

652 What is one-third of 3^6 ?

- 1 1^2
- 2 3^2
- 3 3^5
- 4 9^6

653 The product of $\frac{4x^2}{7y^2}$ and $\frac{21y^3}{20x^4}$, expressed in simplest form, is

- 1 $0.6x^2y$
- 2 $\frac{3y}{5x^2}$
- 3 $\frac{12x^2y^3}{20x^4y^2}$
- 4 $\frac{84x^2y^3}{140x^4y^2}$

654 The expression $\frac{24x^6y^3}{-6x^3y}$ is equivalent to

- 1 $-4x^2y^3$
- 2 $-4x^3y^3$
- 3 $-4x^9y^4$
- 4 $-4x^3y^2$

A.A.12: POWERS OF POWERS

655 Which expression is equivalent to $(3x^2)^3$?

- 1 $9x^5$
- 2 $9x^6$
- 3 $27x^5$
- 4 $27x^6$

656 The expression $\frac{(10w^3)^2}{5w}$ is equivalent to

- 1 $2w^5$
- 2 $2w^8$
- 3 $20w^5$
- 4 $20w^8$

657 The expression $\frac{(4x^3)^2}{2x}$ is equivalent to

- 1 $4x^4$
- 2 $4x^5$
- 3 $8x^4$
- 4 $8x^5$

658 If the expression $(2y^a)^4$ is equivalent to $16y^8$, what is the value of a ?

- 1 12
- 2 2
- 3 32
- 4 4

659 Which equation is true?

- 1 $\frac{c^5}{d^7} \div \frac{d^3}{c} = \frac{c^4}{d^4}$
- 2 $(-2m^2p)^3 = -8m^6p^3$
- 3 $\left(\frac{s^3t^8}{s^4t^5}\right)^2 = \frac{t^5}{s^2}$
- 4 $(-2a^2b^3)(3ab^2) = a^3b^5$

A.N.4: OPERATIONS WITH SCIENTIFIC NOTATION

660 What is the quotient of 8.05×10^6 and 3.5×10^2 ?

- 1 2.3×10^3
- 2 2.3×10^4
- 3 2.3×10^8
- 4 2.3×10^{12}

661 What is the product of 8.4×10^8 and 4.2×10^3 written in scientific notation?

- 1 2.0×10^5
- 2 12.6×10^{11}
- 3 35.28×10^{11}
- 4 3.528×10^{12}

662 What is the product of 12 and 4.2×10^6 expressed in scientific notation?

- 1 50.4×10^6
- 2 50.4×10^7
- 3 5.04×10^6
- 4 5.04×10^7

663 The quotient of (9.2×10^6) and (2.3×10^2) expressed in scientific notation is

- 1 4,000
- 2 40,000
- 3 4×10^3
- 4 4×10^4

664 What is the product of (6×10^3) , (4.6×10^5) , and (2×10^{-2}) expressed in scientific notation?

- 1 55.2×10^6
- 2 5.52×10^7
- 3 55.2×10^7
- 4 5.52×10^{10}

665 State the value of the expression $\frac{(4.1 \times 10^2)(2.4 \times 10^3)}{(1.5 \times 10^7)}$ in scientific notation.

666 The expression $\frac{6 \times 10^{-7}}{3 \times 10^{-3}}$ is equivalent to

- 1 2×10^4
- 2 2×10^{10}
- 3 2×10^{-4}
- 4 2×10^{-10}

667 What is the product of (1.5×10^2) and (8.4×10^3) expressed in scientific notation?

- 1 1.26×10^5
- 2 12.6×10^5
- 3 1.26×10^6
- 4 12.6×10^6

668 If $(7.6 \times 10^n)(3.5 \times 10^3) = 2.66 \times 10^9$, what is the value of n ?

- 1 6
- 2 5
- 3 3
- 4 7

A.A.9: EXPONENTIAL FUNCTIONS

669 Daniel's Print Shop purchased a new printer for \$35,000. Each year it depreciates (loses value) at a rate of 5%. What will its approximate value be at the end of the fourth year?

- 1 \$33,250.00
- 2 \$30,008.13
- 3 \$28,507.72
- 4 \$27,082.33

670 Kathy plans to purchase a car that depreciates (loses value) at a rate of 14% per year. The initial cost of the car is \$21,000. Which equation represents the value, v , of the car after 3 years?

- 1 $v = 21,000(0.14)^3$
- 2 $v = 21,000(0.86)^3$
- 3 $v = 21,000(1.14)^3$
- 4 $v = 21,000(0.86)(3)$

671 The New York Volleyball Association invited 64 teams to compete in a tournament. After each round, half of the teams were eliminated. Which equation represents the number of teams, t , that remained in the tournament after r rounds?

- 1 $t = 64(r)^{0.5}$
- 2 $t = 64(-0.5)^r$
- 3 $t = 64(1.5)^r$
- 4 $t = 64(0.5)^r$

672 A bank is advertising that new customers can open a savings account with a $3\frac{3}{4}\%$ interest rate

compounded annually. Robert invests \$5,000 in an account at this rate. If he makes no additional deposits or withdrawals on his account, find the amount of money he will have, to the *nearest cent*, after three years.

673 Cassandra bought an antique dresser for \$500. If the value of her dresser increases 6% annually, what will be the value of Cassandra's dresser at the end of 3 years to the *nearest dollar*?

- 1 \$415
- 2 \$590
- 3 \$596
- 4 \$770

- 674 In a science fiction novel, the main character found a mysterious rock that decreased in size each day. The table below shows the part of the rock that remained at noon on successive days.

Day	Fractional Part of the Rock Remaining
1	1
2	$\frac{1}{2}$
3	$\frac{1}{4}$
4	$\frac{1}{8}$

Which fractional part of the rock will remain at noon on day 7?

- 1 $\frac{1}{128}$
 2 $\frac{1}{64}$
 3 $\frac{1}{14}$
 4 $\frac{1}{12}$
- 675 The value, y , of a \$15,000 investment over x years is represented by the equation $y = 15000(1.2)^{\frac{x}{3}}$. What is the profit (interest) on a 6-year investment?
- 1 \$6,600
 2 \$10,799
 3 \$21,600
 4 \$25,799
- 676 The Booster Club raised \$30,000 for a sports fund. No more money will be placed into the fund. Each year the fund will decrease by 5%. Determine the amount of money, to the *nearest cent*, that will be left in the sports fund after 4 years.

- 677 The value of a car purchased for \$20,000 decreases at a rate of 12% per year. What will be the value of the car after 3 years?
- 1 \$12,800.00
 2 \$13,629.44
 3 \$17,600.00
 4 \$28,098.56

- 678 The current student population of the Brentwood Student Center is 2,000. The enrollment at the center increases at a rate of 4% each year. To the *nearest whole number*, what will the student population be closest to in 3 years?
- 1 2,240
 2 2,250
 3 5,488
 4 6,240

- 679 Mr. Smith invested \$2,500 in a savings account that earns 3% interest compounded annually. He made no additional deposits or withdrawals. Which expression can be used to determine the number of dollars in this account at the end of 4 years?
- 1 $2500(1 + 0.03)^4$
 2 $2500(1 + 0.3)^4$
 3 $2500(1 + 0.04)^3$
 4 $2500(1 + 0.4)^3$

- 680 A car depreciates (loses value) at a rate of 4.5% annually. Greg purchased a car for \$12,500. Which equation can be used to determine the value of the car, V , after 5 years?
- 1 $V = 12,500(0.55)^5$
 2 $V = 12,500(0.955)^5$
 3 $V = 12,500(1.045)^5$
 4 $V = 12,500(1.45)^5$

- 681 Is the equation $A = 21000(1 - 0.12)^t$ a model of exponential growth or exponential decay, and what is the rate (percent) of change per time period?
- 1 exponential growth and 12%
 - 2 exponential growth and 88%
 - 3 exponential decay and 12%
 - 4 exponential decay and 88%

- 682 The current population of a town is 10,000. If the population, P , increases by 20% each year, which equation could be used to find the population after t years?
- 1 $P = 10,000(0.2)^t$
 - 2 $P = 10,000(0.8)^t$
 - 3 $P = 10,000(1.2)^t$
 - 4 $P = 10,000(1.8)^t$

- 683 Adrienne invested \$2000 in an account at a 3.5% interest rate compounded annually. She made no deposits or withdrawals on the account for 4 years. Determine, to the *nearest dollar*, the balance in the account after the 4 years.

- 684 Kirsten invested \$1000 in an account at an annual interest rate of 3%. She made no deposits or withdrawals on the account for 5 years. The interest was compounded annually. Find the balance in the account, to the *nearest cent*, at the end of 5 years.

- 685 Sheba opened a retirement account with \$36,500. Her account grew at a rate of 7% per year compounded annually. She made no deposits or withdrawals on the account. At the end of 20 years, what was the account worth, to the *nearest dollar*?
- 1 \$87,600
 - 2 \$130,786
 - 3 \$141,243
 - 4 \$1,483,444,463

A.G.4: GRAPHING EXPONENTIAL FUNCTIONS

- 686 On the set of axes below, draw the graph of $y = 2^x$ over the interval $-1 \leq x \leq 3$. Will this graph ever intersect the x -axis? Justify your answer.

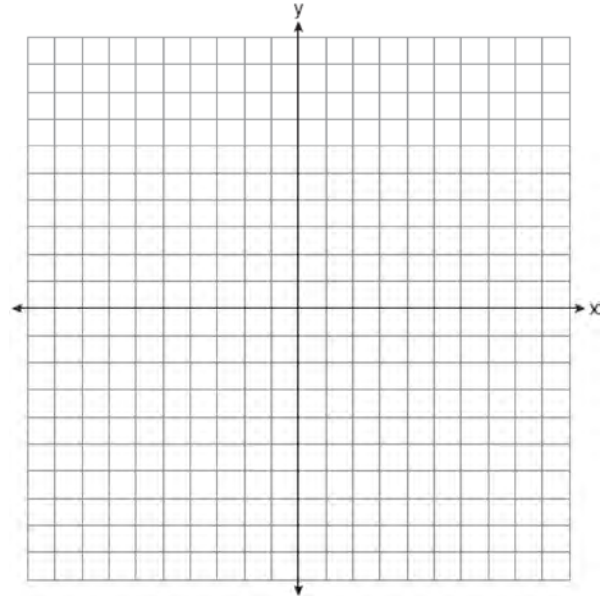

- 687 On the set of axes below, graph $y = 3^x$ over the interval $-1 \leq x \leq 2$.

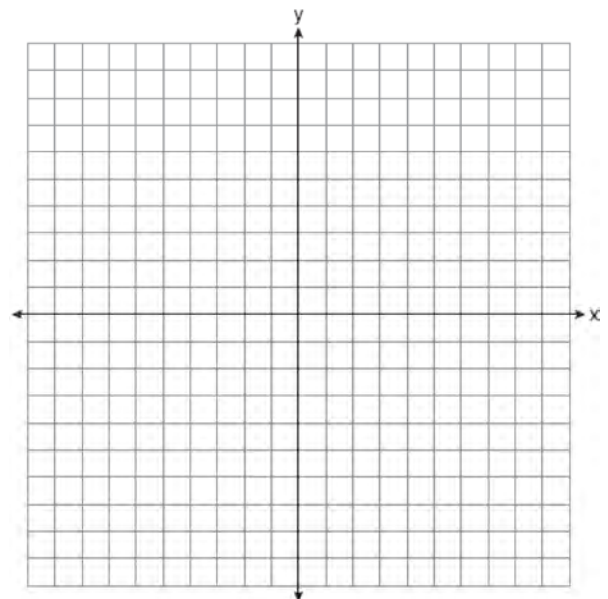

688 Which graph represents the exponential decay of a radioactive element?

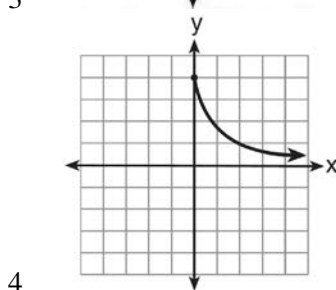
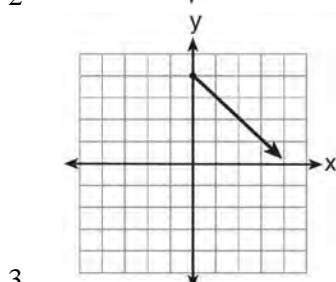
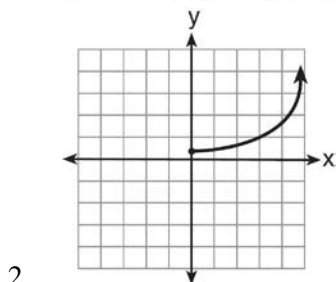
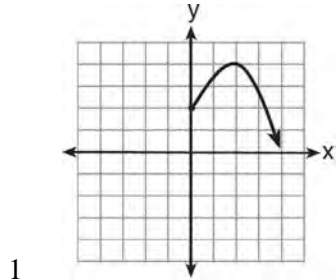

RADICALS

A.N.2: SIMPLIFYING RADICALS

689 Express $5\sqrt{72}$ in simplest radical form.

690 What is $\frac{\sqrt{32}}{4}$ expressed in simplest radical form?

- 1 $\sqrt{2}$
- 2 $4\sqrt{2}$
- 3 $\sqrt{8}$
- 4 $\frac{\sqrt{8}}{2}$

691 What is $\sqrt{72}$ expressed in simplest radical form?

- 1 $2\sqrt{18}$
- 2 $3\sqrt{8}$
- 3 $6\sqrt{2}$
- 4 $8\sqrt{3}$

692 What is $\sqrt{32}$ expressed in simplest radical form?

- 1 $16\sqrt{2}$
- 2 $4\sqrt{2}$
- 3 $4\sqrt{8}$
- 4 $2\sqrt{8}$

693 When $5\sqrt{20}$ is written in simplest radical form, the result is $k\sqrt{5}$. What is the value of k ?

- 1 20
- 2 10
- 3 7
- 4 4

694 Express $-3\sqrt{48}$ in simplest radical form.

695 What is $3\sqrt{250}$ expressed in simplest radical form?

- 1 $5\sqrt{10}$
- 2 $8\sqrt{10}$
- 3 $15\sqrt{10}$
- 4 $75\sqrt{10}$

696 What is $2\sqrt{45}$ expressed in simplest radical form?

- 1 $3\sqrt{5}$
- 2 $5\sqrt{5}$
- 3 $6\sqrt{5}$
- 4 $18\sqrt{5}$

697 Express $4\sqrt{75}$ in simplest radical form.

698 Express $2\sqrt{108}$ in simplest radical form.

A.N.3: OPERATIONS WITH RADICALS

699 Express the product of $3\sqrt{20}(2\sqrt{5} - 7)$ in simplest radical form.

700 The expression $6\sqrt{50} + 6\sqrt{2}$ written in simplest radical form is

- 1 $6\sqrt{52}$
- 2 $12\sqrt{52}$
- 3 $17\sqrt{2}$
- 4 $36\sqrt{2}$

701 The expression $\sqrt{72} - 3\sqrt{2}$ written in simplest radical form is

- 1 $5\sqrt{2}$
- 2 $3\sqrt{6}$
- 3 $3\sqrt{2}$
- 4 $\sqrt{6}$

702 What is $3\sqrt{2} + \sqrt{8}$ expressed in simplest radical form?

- 1 $3\sqrt{10}$
- 2 $3\sqrt{16}$
- 3 $5\sqrt{2}$
- 4 $7\sqrt{2}$

703 Express $\frac{16\sqrt{21}}{2\sqrt{7}} - 5\sqrt{12}$ in simplest radical form.

704 Express $\frac{3\sqrt{75} + \sqrt{27}}{3}$ in simplest radical form.

705 Express $\sqrt{25} - 2\sqrt{3} + \sqrt{27} + 2\sqrt{9}$ in simplest radical form.

706 Express $\frac{\sqrt{84}}{2\sqrt{3}}$ in simplest radical form.

707 Perform the indicated operations and express the answer in simplest radical form.

$$3\sqrt{7}(\sqrt{14} + 4\sqrt{56})$$

708 Express $y\sqrt{3} - (\sqrt{32} + y\sqrt{27})$ in simplest radical form.

709 What is $\sqrt{150} + \sqrt{24}$ expressed in simplest radical form?

- 1 $7\sqrt{6}$
- 2 $7\sqrt{12}$
- 3 $\sqrt{87}$
- 4 $\sqrt{174}$

710 Which value is equivalent to the product of $4\sqrt{2}$ and $2\sqrt{6}$?

- 1 $16\sqrt{3}$
- 2 $6\sqrt{12}$
- 3 $6\sqrt{8}$
- 4 $24\sqrt{2}$

RATIONALS

A.A.16: RATIONAL EXPRESSIONS

711 The expression $\frac{9x^4 - 27x^6}{3x^3}$ is equivalent to

- 1 $3x(1 - 3x)$
- 2 $3x(1 - 3x^2)$
- 3 $3x(1 - 9x^5)$
- 4 $9x^3(1 - x)$

712 Which expression represents $\frac{2x^2 - 12x}{x - 6}$ in simplest form?

- 1 0
- 2 $2x$
- 3 $4x$
- 4 $2x + 2$

713 Which expression represents $\frac{25x - 125}{x^2 - 25}$ in simplest form?

- 1 $\frac{5}{x}$
- 2 $\frac{-5}{x}$
- 3 $\frac{25}{x - 5}$
- 4 $\frac{25}{x + 5}$

714 Which expression represents $\frac{x^2 - 2x - 15}{x^2 + 3x}$ in simplest form?

- 1 -5
- 2 $\frac{x - 5}{x}$
- 3 $\frac{-2x - 5}{x}$
- 4 $\frac{-2x - 15}{3x}$

715 Which expression represents $\frac{x^2 - x - 6}{x^2 - 5x + 6}$ in simplest form?

- 1 $\frac{x + 2}{x - 2}$
- 2 $\frac{-x - 6}{-5x + 6}$
- 3 $\frac{1}{5}$
- 4 -1

716 The area of a rectangle is represented by $x^2 - 5x - 24$. If the width of the rectangle is represented by $x - 8$, express the length of the rectangle as a binomial.

717 Express in simplest form: $\frac{x^2 - 1}{x^2 + 3x + 2}$

718 Which expression represents $\frac{x^2 - 3x - 10}{x^2 - 25}$ in simplest form?

- 1 $\frac{2}{5}$
- 2 $\frac{x + 2}{x + 5}$
- 3 $\frac{x - 2}{x - 5}$
- 4 $\frac{-3x - 10}{-25}$

719 Which expression is equivalent to $\frac{2x^6 - 18x^4 + 2x^2}{2x^2}$?

- 1 $x^3 - 9x^2$
- 2 $x^4 - 9x^2$
- 3 $x^3 - 9x^2 + 1$
- 4 $x^4 - 9x^2 + 1$

720 The expression $\frac{2x^2 + 10x - 28}{4x + 28}$ is equivalent to

- 1 $\frac{x-2}{2}$
- 2 $x-1$
- 3 $\frac{x+2}{2}$
- 4 $\frac{x+5}{2}$

721 If the area of a rectangle is represented by $x^2 + 8x + 15$ and its length is represented by $x + 5$, which expression represents the width of the rectangle?

- 1 $x+3$
- 2 $x-3$
- 3 $x^2 + 6x + 5$
- 4 $x^2 + 7x + 10$

722 Which fraction represents $\frac{x^2 - 25}{x^2 - x - 20}$ expressed in simplest form?

- 1 $\frac{5}{4}$
- 2 $\frac{x-5}{x-4}$
- 3 $\frac{x+5}{x+4}$
- 4 $\frac{25}{x+20}$

A.A.15: UNDEFINED RATIONALS

723 For which value of x is $\frac{x-3}{x^2-4}$ undefined?

- 1 -2
- 2 0
- 3 3
- 4 4

724 Which value of x makes the expression $\frac{x+4}{x-3}$ undefined?

- 1 -4
- 2 -3
- 3 3
- 4 0

725 The function $y = \frac{x}{x^2 - 9}$ is undefined when the value of x is

- 1 0 or 3
- 2 3 or -3
- 3 3 , only
- 4 -3 , only

726 Which value of n makes the expression $\frac{5n}{2n-1}$ undefined?

- 1 1
- 2 0
- 3 $-\frac{1}{2}$
- 4 $\frac{1}{2}$

727 Which value of x makes the expression

$\frac{x^2 - 9}{x^2 + 7x + 10}$ undefined?

- 1 -5
- 2 2
- 3 3
- 4 -3

728 The algebraic expression $\frac{x-2}{x^2-9}$ is undefined when

- x is
- 1 0
 - 2 2
 - 3 3
 - 4 9

Integrated Algebra Regents Exam Questions by Performance Indicator: Topic

www.jmap.org

729 For which set of values of x is the algebraic

expression $\frac{x^2 - 16}{x^2 - 4x - 12}$ undefined?

- 1 $\{-6, 2\}$
- 2 $\{-4, 3\}$
- 3 $\{-4, 4\}$
- 4 $\{-2, 6\}$

730 For which values of x is the fraction $\frac{x^2 + x - 6}{x^2 + 5x - 6}$

undefined?

- 1 1 and -6
- 2 2 and -3
- 3 3 and -2
- 4 6 and -1

731 The expression $\frac{14 + x}{x^2 - 4}$ is undefined when x is

- 1 -14 , only
- 2 2 , only
- 3 -2 or 2
- 4 -14 , -2 , or 2

732 The expression $\frac{x - 3}{x + 2}$ is undefined when the value of x is

- 1 -2 , only
- 2 -2 and 3
- 3 3 , only
- 4 -3 and 2

733 A value of x that makes the expression

$\frac{x^2 + 4x - 12}{x^2 - 2x - 15}$ undefined is

- 1 -6
- 2 -2
- 3 3
- 4 5

734 The expression $\frac{x - 7}{9 - x^2}$ is undefined when x is

- 1 3 and 7
- 2 3 and -3
- 3 3, only
- 4 9

735 The expression $\frac{2x^2 + 10x - 28}{4x + 28}$ is undefined when

x is

- 1 7, only
- 2 -7 , only
- 3 7 or -2
- 4 -7 or 2

736 For which value of x is the expression $\frac{x + 2}{2x - 1}$

undefined?

- 1 0
- 2 -2
- 3 $-\frac{1}{2}$
- 4 $\frac{1}{2}$

737 Which value of x makes the expression $\frac{x + 9}{3x - 6}$

undefined?

- 1 -9
- 2 2
- 3 -3
- 4 0

A.A.18: MULTIPLICATION AND DIVISION OF RATIONALS

738 What is the product of $\frac{x^2 - 1}{x + 1}$ and $\frac{x + 3}{3x - 3}$

expressed in simplest form?

- 1 x
- 2 $\frac{x}{3}$
- 3 $x + 3$
- 4 $\frac{x + 3}{3}$

Integrated Algebra Regents Exam Questions by Performance Indicator: Topic

739 What is the product of $\frac{4x}{x-1}$ and $\frac{x^2-1}{3x+3}$ expressed in simplest form?

- 1 $\frac{4x}{3}$
- 2 $\frac{4x^2}{3}$
- 3 $\frac{4x^2}{3(x+1)}$
- 4 $\frac{4(x+1)}{3}$

740 Perform the indicated operation and simplify:

$$\frac{3x+6}{4x+12} \div \frac{x^2-4}{x+3}$$

741 Express in simplest form: $\frac{2x^2-8x-42}{6x^2} \div \frac{x^2-9}{x^2-3x}$

742 Express in simplest form:

$$\frac{x^2+9x+14}{x^2-49} \div \frac{3x+6}{x^2+x-56}$$

743 What is the quotient of $\frac{x}{x+4}$ divided by $\frac{2x}{x^2-16}$?

- 1 $\frac{2}{x-4}$
- 2 $\frac{2x^2}{x-4}$
- 3 $\frac{2x^2}{x^2-16}$
- 4 $\frac{x-4}{2}$

744 Express the product of $\frac{x+2}{2}$ and $\frac{4x+20}{x^2+6x+8}$ in simplest form.

745 Express $\frac{3x^2+9x}{x^2+5x+6} \div \frac{x^2-9}{x^2-x-6}$ in simplest form.

746 Perform the indicated operations and express the result in simplest form:

$$\left(\frac{10x^2y}{x^2+xy} \right) \cdot \left(\frac{(x+y)^2}{2x} \right) \div \left(\frac{x^2-y^2}{5y^2} \right)$$

A.A.17: ADDITION AND SUBTRACTION OF RATIONALS

747 What is the sum of $\frac{d}{2}$ and $\frac{2d}{3}$ expressed in simplest form?

- 1 $\frac{3d}{5}$
- 2 $\frac{3d}{6}$
- 3 $\frac{7d}{5}$
- 4 $\frac{7d}{6}$

748 What is $\frac{6}{5x} - \frac{2}{3x}$ in simplest form?

- 1 $\frac{8}{15x^2}$
- 2 $\frac{8}{15x}$
- 3 $\frac{4}{15x}$
- 4 $\frac{4}{2x}$

749 What is $\frac{6}{4a} - \frac{2}{3a}$ expressed in simplest form?

- 1 $\frac{4}{a}$
- 2 $\frac{5}{6a}$
- 3 $\frac{8}{7a}$
- 4 $\frac{10}{12a}$

750 What is the sum of $\frac{3}{2x}$ and $\frac{4}{3x}$ expressed in simplest form?

- 1 $\frac{12}{6x^2}$
- 2 $\frac{17}{6x}$
- 3 $\frac{7}{5x}$
- 4 $\frac{17}{12x}$

751 What is the sum of $\frac{3x^2}{x-2}$ and $\frac{x^2}{x-2}$?

- 1 $\frac{3x^4}{(x-2)^2}$
- 2 $\frac{3x^4}{x-2}$
- 3 $\frac{4x^2}{(x-2)^2}$
- 4 $\frac{4x^2}{x-2}$

752 What is the sum of $\frac{-x+7}{2x+4}$ and $\frac{2x+5}{2x+4}$?

- 1 $\frac{x+12}{2x+4}$
- 2 $\frac{3x+12}{2x+4}$
- 3 $\frac{x+12}{4x+8}$
- 4 $\frac{3x+12}{4x+8}$

753 What is $\frac{2+x}{5x} - \frac{x-2}{5x}$ expressed in simplest form?

- 1 0
- 2 $\frac{2}{5}$
- 3 $\frac{4}{5x}$
- 4 $\frac{2x+4}{5x}$

754 What is the sum of $\frac{3}{2x}$ and $\frac{7}{4x}$?

- 1 $\frac{21}{8x^2}$
- 2 $\frac{13}{4x}$
- 3 $\frac{10}{6x}$
- 4 $\frac{13}{8x}$

755 What is $\frac{7}{12x} - \frac{y}{6x^2}$ expressed in simplest form?

- 1 $\frac{7-y}{6x}$
- 2 $\frac{7-y}{12x-6x^2}$
- 3 $-\frac{7y}{12x^2}$
- 4 $\frac{7x-2y}{12x^2}$

756 What is the sum of $\frac{2y}{y+5}$ and $\frac{10}{y+5}$ expressed in simplest form?

- 1 1
- 2 2
- 3 $\frac{12y}{y+5}$
- 4 $\frac{2y+10}{y+5}$

757 The expression $\frac{2x+13}{2x+6} - \frac{3x-6}{2x+6}$ is equivalent to

- 1 $\frac{-x+19}{2(x+3)}$
- 2 $\frac{-x+7}{2(x+3)}$
- 3 $\frac{5x+19}{2(x+3)}$
- 4 $\frac{5x+7}{4x+12}$

758 Which fraction is equivalent to $\frac{4}{3a} - \frac{5}{2a}$?

- 1 $-\frac{1}{a}$
- 2 $-\frac{1}{5a}$
- 3 $-\frac{7}{6a}$
- 4 $-\frac{7}{6a^2}$

759 The expression $\frac{2n}{5} + \frac{3n}{2}$ is equivalent to

- 1 $\frac{5n}{7}$
- 2 $\frac{6n^2}{10}$
- 3 $\frac{19n}{10}$
- 4 $\frac{7n}{10}$

760 The expression $\frac{a}{b} - \frac{1}{3}$ is equivalent to

- 1 $\frac{a-1}{b-3}$
- 2 $\frac{a-1}{3b}$
- 3 $\frac{3a-b}{3b}$
- 4 $\frac{3a-b}{b-3}$

761 The sum of $\frac{3x-4}{x+3}$ and $\frac{2x-5}{x+3}$ is

- 1 $\frac{5x-9}{x+3}$
- 2 $\frac{5x+1}{2x+6}$
- 3 $\frac{5x-9}{x+6}$
- 4 $\frac{5x+1}{x+3}$

762 What is $\frac{10}{7x} - \frac{3}{5x}$ expressed in simplest form?

- 1 $\frac{7}{2x}$
- 2 $\frac{29}{2x}$
- 3 $\frac{29}{35x}$
- 4 $\frac{55}{35x}$

A.A.26: SOLVING RATIONALS

763 Solve for x : $\frac{x+1}{x} = \frac{-7}{x-12}$

764 Which value of x is a solution of $\frac{5}{x} = \frac{x+13}{6}$?

- 1 -2
- 2 -3
- 3 -10
- 4 -15

765 What is the solution of $\frac{k+4}{2} = \frac{k+9}{3}$?

- 1 1
- 2 5
- 3 6
- 4 14

Integrated Algebra Regents Exam Questions by Performance Indicator: Topic

www.jmap.org

766 What is the value of x in the equation

$$\frac{2}{x} - 3 = \frac{26}{x}?$$

- 1 -8
- 2 $-\frac{1}{8}$
- 3 $\frac{1}{8}$
- 4 8

767 What is the solution set of $\frac{x+2}{x-2} = \frac{-3}{x}$?

- 1 $\{-2, 3\}$
- 2 $\{-3, -2\}$
- 3 $\{-1, 6\}$
- 4 $\{-6, 1\}$

768 Which value of x is the solution of $\frac{2x-3}{x-4} = \frac{2}{3}$?

- 1 $-\frac{1}{4}$
- 2 $\frac{1}{4}$
- 3 -4
- 4 4

769 Solve algebraically for x : $\frac{x+2}{6} = \frac{3}{x-1}$

770 Solve algebraically for x : $\frac{3}{4} = \frac{-(x+11)}{4x} + \frac{1}{2x}$

771 What is the solution of $\frac{2}{x+1} = \frac{x+1}{2}$?

- 1 -1 and -3
- 2 -1 and 3
- 3 1 and -3
- 4 1 and 3

772 What is the solution of the equation $\frac{x+2}{2} = \frac{4}{x}$?

- 1 1 and -8
- 2 2 and -4
- 3 -1 and 8
- 4 -2 and 4

773 Solve algebraically: $\frac{2}{3x} + \frac{4}{x} = \frac{7}{x+1}$

[Only an algebraic solution can receive full credit.]

774 Solve algebraically for all values of x :

$$\frac{3}{x+5} = \frac{2x}{x^2-8}$$

775 What is the solution of the equation

$$\frac{12}{7x} + \frac{3}{2x} = \frac{15}{14}?$$

- 1 1
- 2 5
- 3 3
- 4 14

776 What is the solution of the equation $\frac{x}{3} = \frac{8}{x+2}$?

- 1 $\{-6, -4\}$
- 2 $\{-6, 4\}$
- 3 $\{6, -4\}$
- 4 $\{6, 4\}$

777 Which value of x is the solution of $\frac{1}{5} + \frac{2}{x} = \frac{1}{3}$?

- 1 $-2\frac{3}{4}$
- 2 -15
- 3 $2\frac{3}{4}$
- 4 15

FUNCTIONS

A.G.4: FAMILIES OF FUNCTIONS

778 Which type of graph is shown in the diagram below?

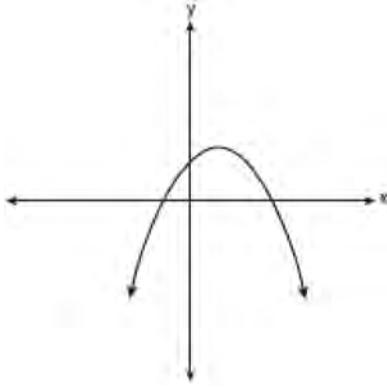

- 1 absolute value
- 2 exponential
- 3 linear
- 4 quadratic

779 Which graph represents a linear function?

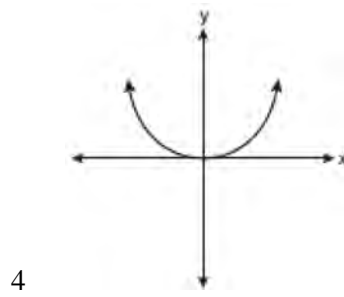
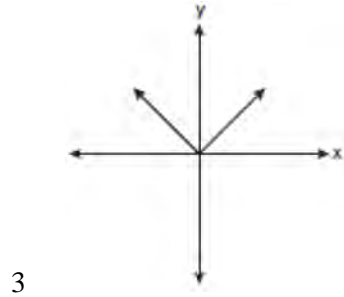
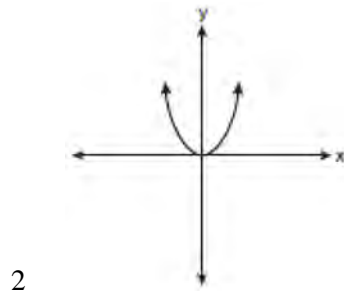
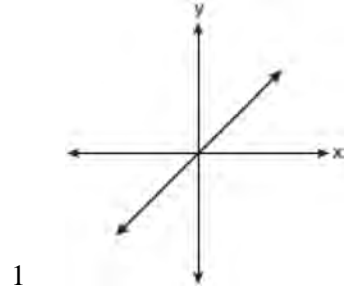

780 Antwaan leaves a cup of hot chocolate on the counter in his kitchen. Which graph is the best representation of the change in temperature of his hot chocolate over time?

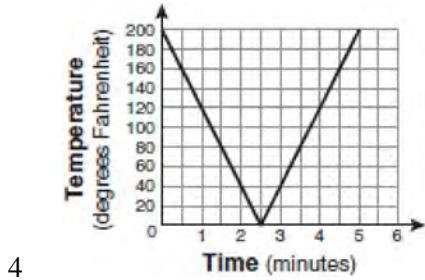
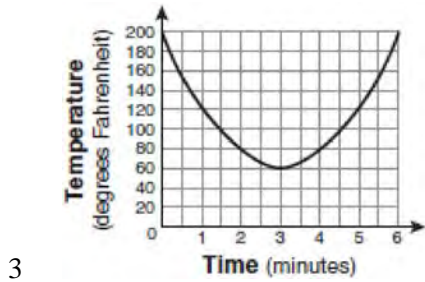
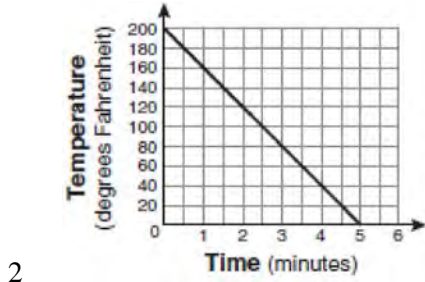
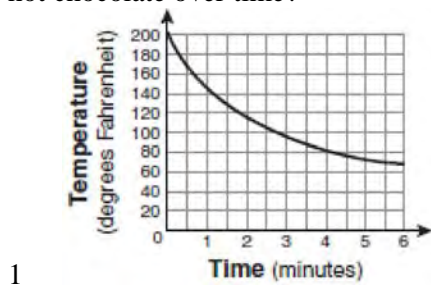

781 Which graph represents an exponential equation?

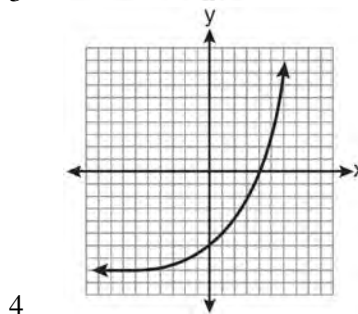
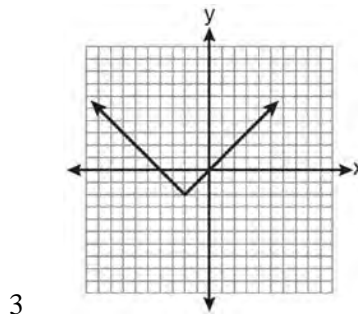
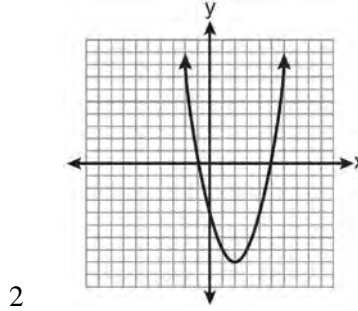
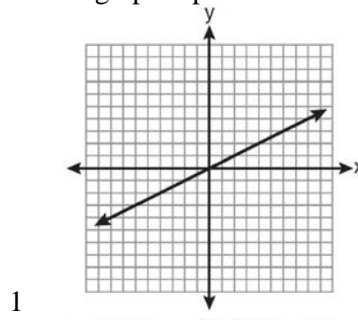

782 Which type of function is represented by the graph shown below?

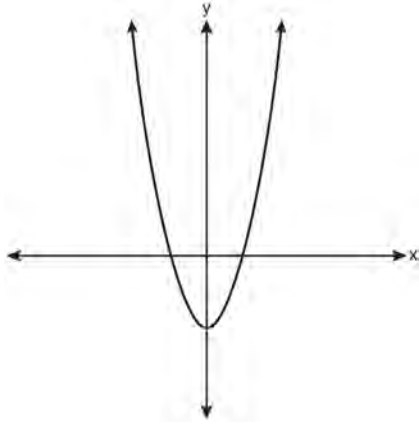

- 1 absolute value
- 2 exponential
- 3 linear
- 4 quadratic

783 Which equation represents a quadratic function?

- 1 $y = x + 2$
- 2 $y = |x + 2|$
- 3 $y = x^2$
- 4 $y = 2^x$

784 Which type of function is graphed below?

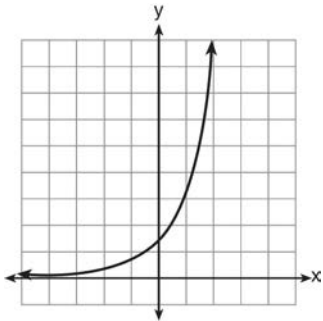

- 1 linear
- 2 quadratic
- 3 exponential
- 4 absolute value

785 Which graph represents an absolute value equation?

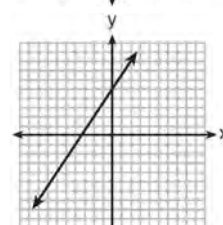
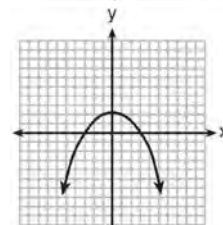
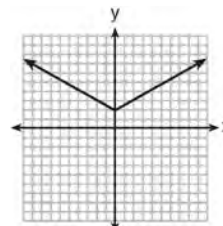
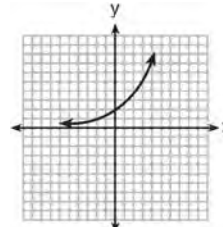

A.G.4: IDENTIFYING THE EQUATION OF A GRAPH

786 Which equation is represented by the graph below?

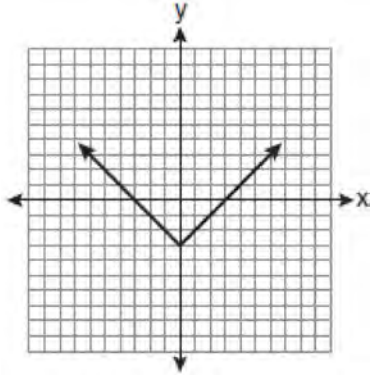

- 1 $y = x^2 - 3$
- 2 $y = (x - 3)^2$
- 3 $y = |x| - 3$
- 4 $y = |x - 3|$

787 Which equation is represented by the graph below?

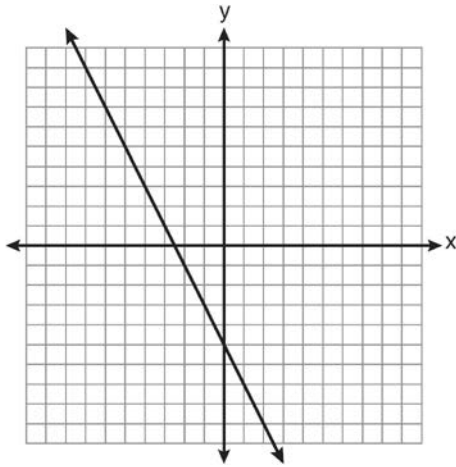

- 1 $2y + x = 10$
- 2 $y - 2x = -5$
- 3 $-2y = 10x - 4$
- 4 $2y = -4x - 10$

A.G.3: DEFINING FUNCTIONS

788 Which graph represents a function?

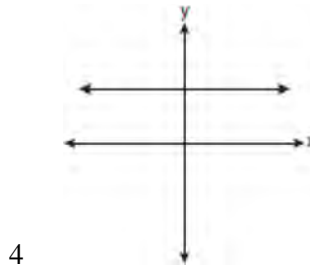
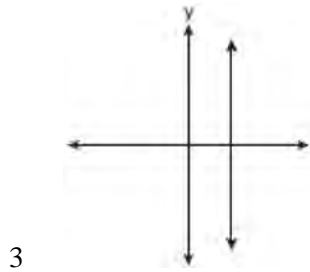
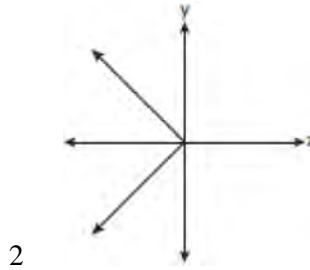
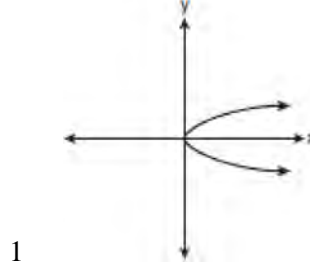

789 Which graph represents a function?

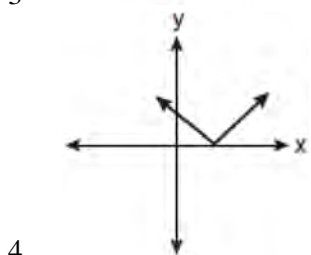
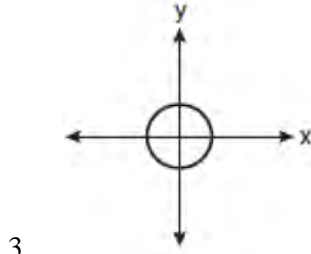
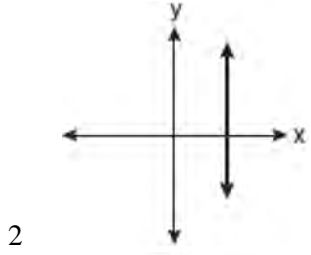
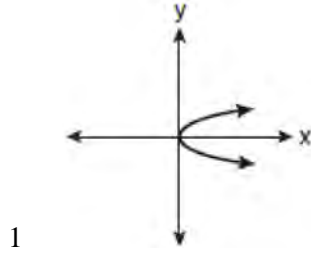

790 Which statement is true about the relation shown on the graph below?

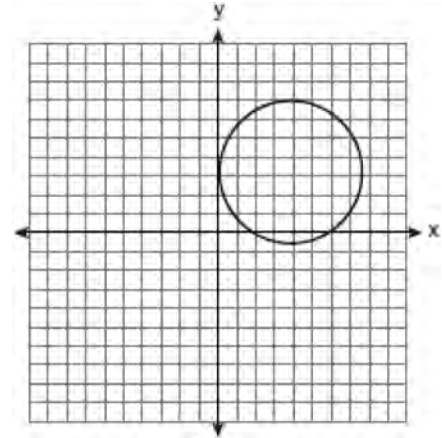

- 1 It is a function because there exists one x -coordinate for each y -coordinate.
- 2 It is a function because there exists one y -coordinate for each x -coordinate.
- 3 It is *not* a function because there are multiple y -values for a given x -value.
- 4 It is *not* a function because there are multiple x -values for a given y -value.

791 Which relation is *not* a function?

- 1 $\{(1, 5), (2, 6), (3, 6), (4, 7)\}$
- 2 $\{(4, 7), (2, 1), (-3, 6), (3, 4)\}$
- 3 $\{(-1, 6), (1, 3), (2, 5), (1, 7)\}$
- 4 $\{(-1, 2), (0, 5), (5, 0), (2, -1)\}$

792 Which relation represents a function?

- 1 $\{(0, 3), (2, 4), (0, 6)\}$
- 2 $\{(-7, 5), (-7, 1), (-10, 3), (-4, 3)\}$
- 3 $\{(2, 0), (6, 2), (6, -2)\}$
- 4 $\{(-6, 5), (-3, 2), (1, 2), (6, 5)\}$

793 Which graph represents a function?

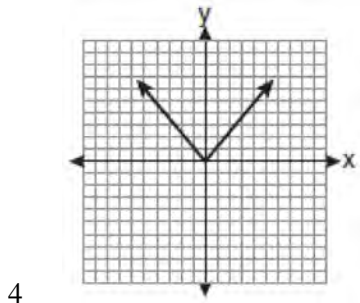
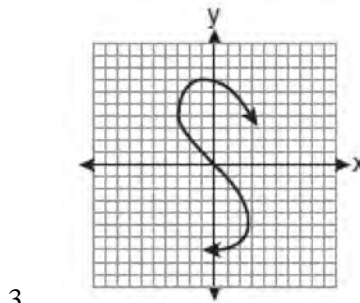
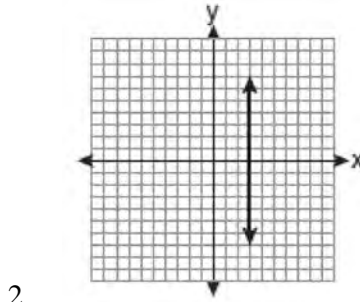
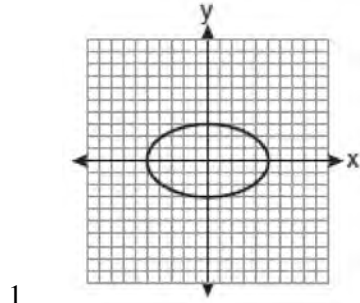

794 Which relation is a function?

1 $\left\{ \left(\frac{3}{4}, 0 \right), (0, 1), \left(\frac{3}{4}, 2 \right) \right\}$

2 $\left\{ (-2, 2), \left(-\frac{1}{2}, 1 \right), (-2, 4) \right\}$

3 $\{(-1, 4), (0, 5), (0, 4)\}$

4 $\{(2, 1), (4, 3), (6, 5)\}$

795 Which set of ordered pairs represents a function?

1 $\{(0, 4), (2, 4), (2, 5)\}$

2 $\{(6, 0), (5, 0), (4, 0)\}$

3 $\{(4, 1), (6, 2), (6, 3), (5, 0)\}$

4 $\{(0, 4), (1, 4), (0, 5), (1, 5)\}$

796 Which graph does *not* represent a function?

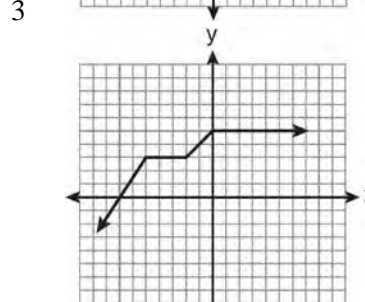
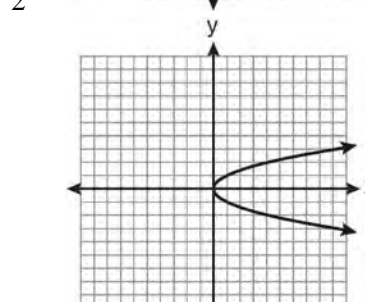
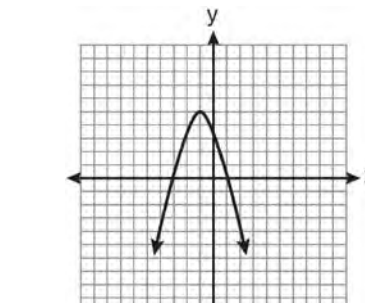
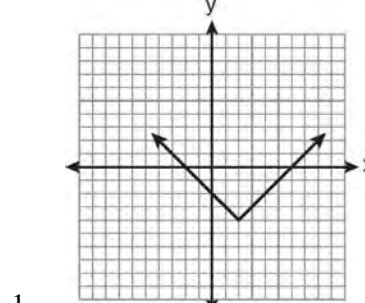

797 Which graph represents a function?

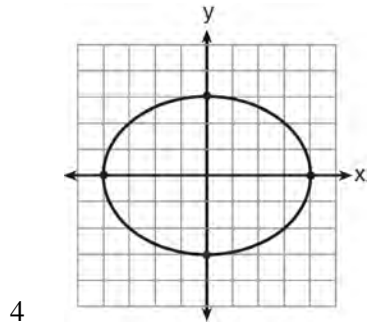
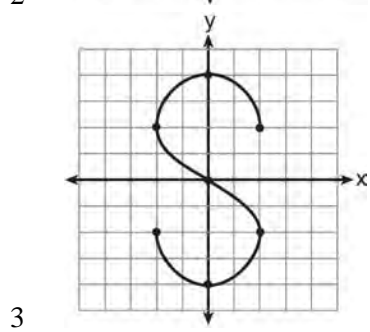
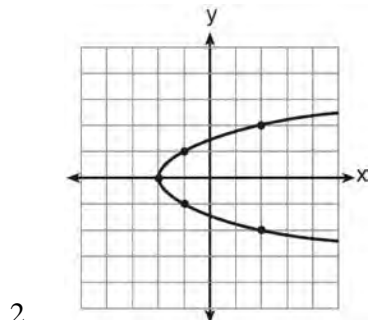
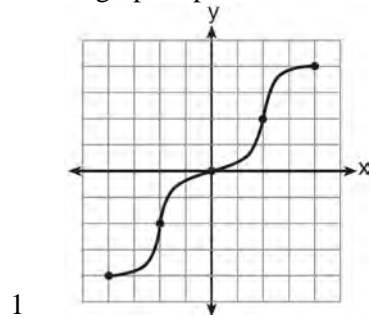

798 Which graph represents a function?

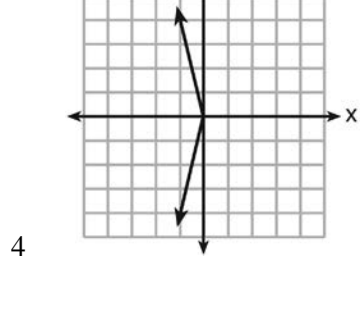
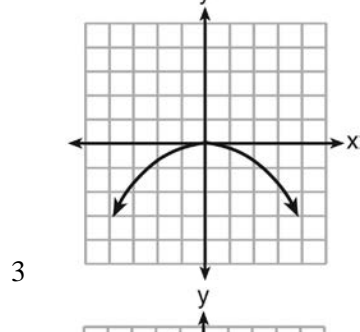
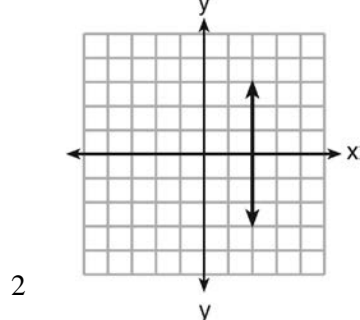
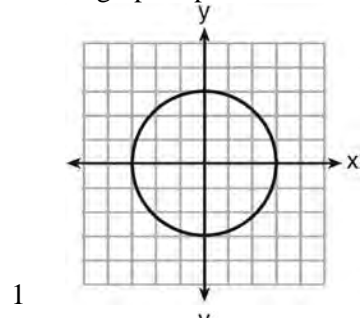

799 Which graph does *not* represent the graph of a function?

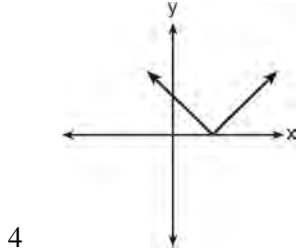
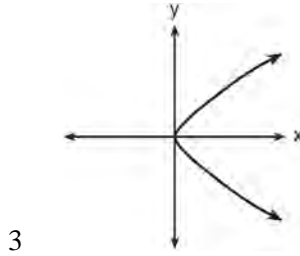
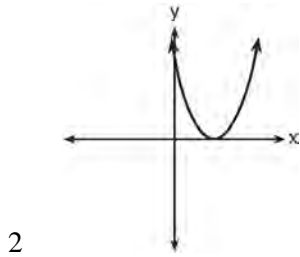
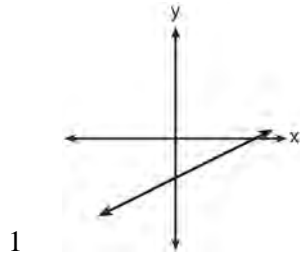

800 Which relation is *not* a function?

- 1 $\{(2, 4), (1, 2), (0, 0), (-1, 2), (-2, 4)\}$
- 2 $\{(2, 4), (1, 1), (0, 0), (-1, 1), (-2, 4)\}$
- 3 $\{(2, 2), (1, 1), (0, 0), (-1, 1), (-2, 2)\}$
- 4 $\{(2, 2), (1, 1), (0, 0), (1, -1), (2, -2)\}$

801 Which relation is a function?

- 1 $\{(2, 1), (3, 1), (4, 1), (5, 1)\}$
- 2 $\{(1, 2), (1, 3), (1, 4), (1, 5)\}$
- 3 $\{(2, 3), (3, 2), (4, 2), (2, 4)\}$
- 4 $\{(1, 6), (2, 8), (3, 9), (3, 12)\}$

802 Which set is a function?

- 1 $\{(3, 4), (3, 5), (3, 6), (3, 7)\}$
- 2 $\{(1, 2), (3, 4), (4, 3), (2, 1)\}$
- 3 $\{(6, 7), (7, 8), (8, 9), (6, 5)\}$
- 4 $\{(0, 2), (3, 4), (0, 8), (5, 6)\}$

TRIANGLES

A.A.45: PYTHAGOREAN THEOREM

803 Tanya runs diagonally across a rectangular field that has a length of 40 yards and a width of 30 yards, as shown in the diagram below.

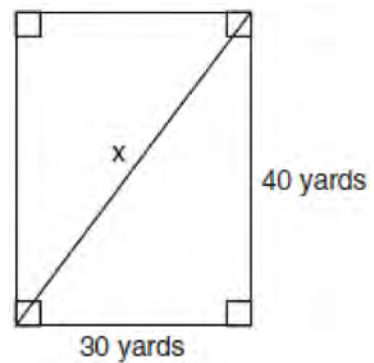

What is the length of the diagonal, in yards, that Tanya runs?

- 1 50
- 2 60
- 3 70
- 4 80

- 804 Don placed a ladder against the side of his house as shown in the diagram below.

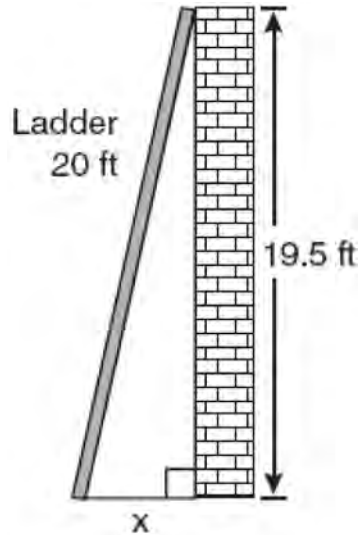

Which equation could be used to find the distance, x , from the foot of the ladder to the base of the house?

- 1 $x = 20 - 19.5$
 - 2 $x = 20^2 - 19.5^2$
 - 3 $x = \sqrt{20^2 - 19.5^2}$
 - 4 $x = \sqrt{20^2 + 19.5^2}$
- 805 The length of the hypotenuse of a right triangle is 34 inches and the length of one of its legs is 16 inches. What is the length, in inches, of the other leg of this right triangle?
- 1 16
 - 2 18
 - 3 25
 - 4 30

- 806 What is the value of x , in inches, in the right triangle below?

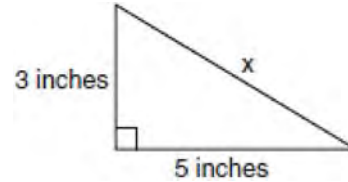

- 1 $\sqrt{15}$
 - 2 8
 - 3 $\sqrt{34}$
 - 4 4
- 807 Nancy's rectangular garden is represented in the diagram below.

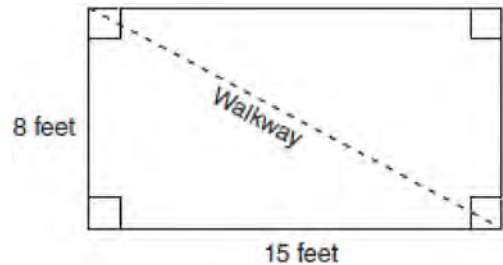

If a diagonal walkway crosses her garden, what is its length, in feet?

- 1 17
- 2 22
- 3 $\sqrt{161}$
- 4 $\sqrt{529}$

- 808 The end of a dog's leash is attached to the top of a 5-foot-tall fence post, as shown in the diagram below. The dog is 7 feet away from the base of the fence post.

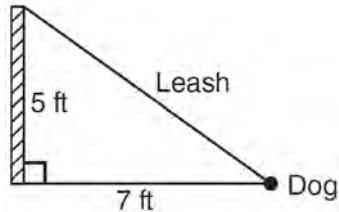

How long is the leash, to the *nearest tenth of a foot*?

- 1 4.9
 - 2 8.6
 - 3 9.0
 - 4 12.0
- 809 The rectangle shown below has a diagonal of 18.4 cm and a width of 7 cm.

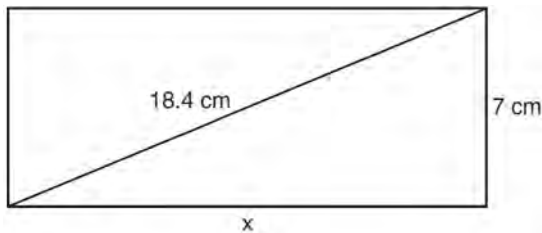

To the *nearest centimeter*, what is the length, x , of the rectangle?

- 1 11
 - 2 17
 - 3 20
 - 4 25
- 810 The legs of an isosceles right triangle each measure 10 inches. What is the length of the hypotenuse of this triangle, to the *nearest tenth of an inch*?
- 1 6.3
 - 2 7.1
 - 3 14.1
 - 4 17.1

- 811 Campsite A and campsite B are located directly opposite each other on the shores of Lake Omega, as shown in the diagram below. The two campsites form a right triangle with Sam's position, S . The distance from campsite B to Sam's position is 1,300 yards, and campsite A is 1,700 yards from his position.

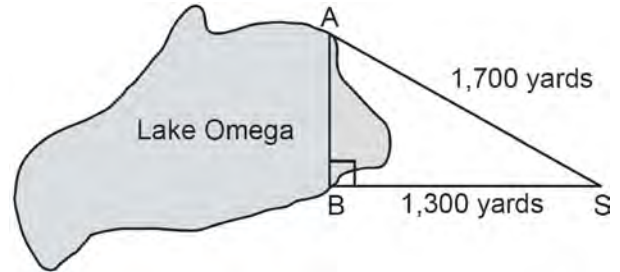

What is the distance from campsite A to campsite B , to the *nearest yard*?

- 1 1,095
 - 2 1,096
 - 3 2,140
 - 4 2,141
- 812 The length of one side of a square is 13 feet. What is the length, to the *nearest foot*, of a diagonal of the square?
- 1 13
 - 2 18
 - 3 19
 - 4 26
- 813 In triangle RST , angle R is a right angle. If $TR = 6$ and $TS = 8$, what is the length of RS ?
- 1 10
 - 2 2
 - 3 $2\sqrt{7}$
 - 4 $7\sqrt{2}$
- 814 In right triangle ABC , $m\angle C = 90$, $AC = 7$, and $AB = 13$. What is the length of BC ?
- 1 6
 - 2 20
 - 3 $\sqrt{120}$
 - 4 $\sqrt{218}$

815 The length and width of a rectangle are 48 inches and 40 inches. To the *nearest inch*, what is the length of its diagonal?

- 1 27
- 2 62
- 3 88
- 4 90

816 The lengths of the sides of a right triangle can be

- 1 9, 12, 15
- 2 8, 10, 13
- 3 5, 5, 10
- 4 4, 5, 6

817 Which set of numbers represents the lengths of the sides of a right triangle?

- 1 {7, 24, 25}
- 2 {9, 16, 23}
- 3 {10, 12, 14}
- 4 {14, 16, 18}

TRIGONOMETRY

A.A.42: TRIGONOMETRIC RATIOS

818 In triangle MCT , the measure of $\angle T = 90^\circ$, $MC = 85$ cm, $CT = 84$ cm, and $TM = 13$ cm. Which ratio represents the sine of $\angle C$?

- 1 $\frac{13}{85}$
- 2 $\frac{84}{85}$
- 3 $\frac{13}{84}$
- 4 $\frac{84}{13}$

819 The diagram below shows right triangle UPC .

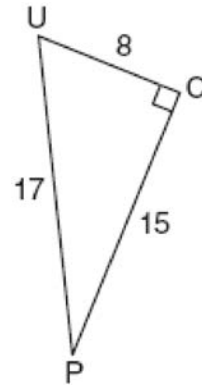

Which ratio represents the sine of $\angle U$?

- 1 $\frac{15}{8}$
- 2 $\frac{15}{17}$
- 3 $\frac{8}{15}$
- 4 $\frac{8}{17}$

820 Which equation shows a correct trigonometric ratio for angle A in the right triangle below?

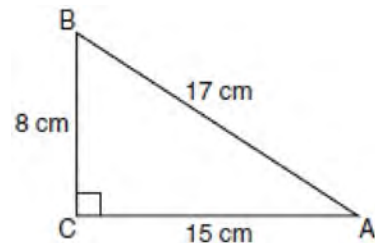

- 1 $\sin A = \frac{15}{17}$
- 2 $\tan A = \frac{8}{17}$
- 3 $\cos A = \frac{15}{17}$
- 4 $\tan A = \frac{5}{8}$

821 In $\triangle ABC$, the measure of $\angle B = 90^\circ$, $AC = 50$, $AB = 48$, and $BC = 14$. Which ratio represents the tangent of $\angle A$?

- 1 $\frac{14}{50}$
- 2 $\frac{14}{48}$
- 3 $\frac{48}{50}$
- 4 $\frac{48}{14}$

822 Right triangle ABC has legs of 8 and 15 and a hypotenuse of 17, as shown in the diagram below.

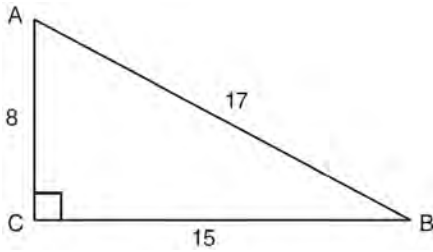

The value of the tangent of $\angle B$ is

- 1 0.4706
- 2 0.5333
- 3 0.8824
- 4 1.8750

823 Which ratio represents $\sin x$ in the right triangle shown below?

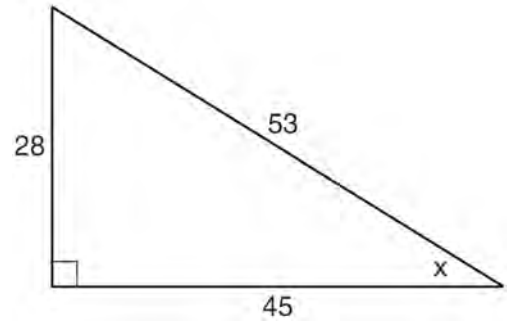

- 1 $\frac{28}{53}$
- 2 $\frac{28}{45}$
- 3 $\frac{45}{53}$
- 4 $\frac{53}{28}$

824 The diagram below shows right triangle ABC .

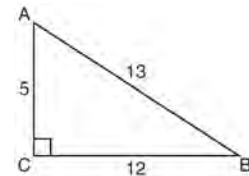

Which ratio represents the tangent of $\angle ABC$?

- 1 $\frac{5}{13}$
- 2 $\frac{5}{12}$
- 3 $\frac{12}{13}$
- 4 $\frac{12}{5}$

825 The diagram below shows right triangle LMP .

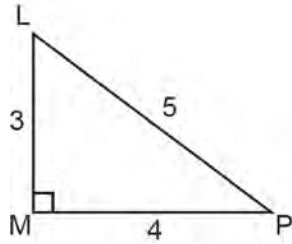

Which ratio represents the tangent of $\angle PLM$?

- 1 $\frac{3}{4}$
- 2 $\frac{3}{5}$
- 3 $\frac{4}{3}$
- 4 $\frac{5}{4}$

826 In $\triangle ABC$, $m\angle C = 90$. If $AB = 5$ and $AC = 4$, which statement is *not* true?

- 1 $\cos A = \frac{4}{5}$
- 2 $\tan A = \frac{3}{4}$
- 3 $\sin B = \frac{4}{5}$
- 4 $\tan B = \frac{5}{3}$

827 In right triangle ABC shown below, what is the value of $\cos A$?

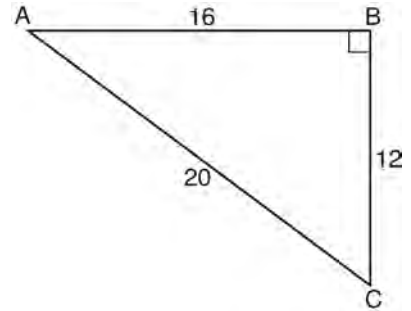

- 1 $\frac{12}{20}$
- 2 $\frac{16}{20}$
- 3 $\frac{20}{12}$
- 4 $\frac{20}{16}$

828 Which ratio represents the cosine of angle A in the right triangle below?

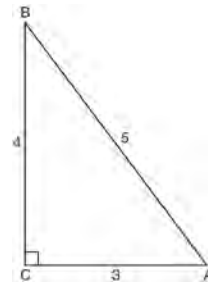

- 1 $\frac{3}{5}$
- 2 $\frac{5}{3}$
- 3 $\frac{4}{5}$
- 4 $\frac{4}{3}$

Integrated Algebra Regents Exam Questions by Performance Indicator: Topic

www.jmap.org

- 829 In right triangle ABC shown below, $AC = 12$, $BC = 16$, and $AB = 20$.

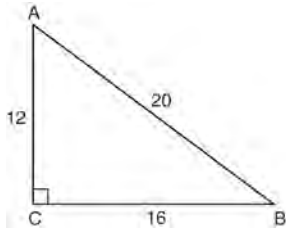

Which equation is *not* correct?

- 1 $\cos A = \frac{12}{20}$
- 2 $\tan A = \frac{16}{12}$
- 3 $\sin B = \frac{12}{20}$
- 4 $\tan B = \frac{16}{20}$

- 830 In right triangle JKL in the diagram below, $KL = 7$, $JK = 24$, $JL = 25$, and $\angle K = 90^\circ$.

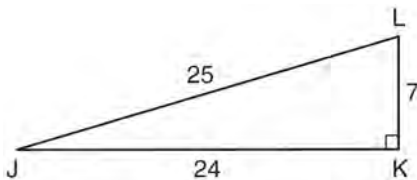

Which statement is *not* true?

- 1 $\tan L = \frac{24}{7}$
- 2 $\cos L = \frac{24}{25}$
- 3 $\tan J = \frac{7}{24}$
- 4 $\sin J = \frac{7}{25}$

- 831 In $\triangle ABC$ below, the measure of $\angle A = 90^\circ$, $AB = 6$, $AC = 8$, and $BC = 10$.

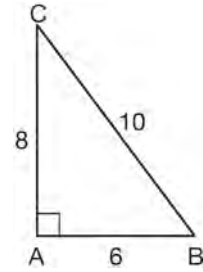

Which ratio represents the sine of $\angle B$?

- 1 $\frac{10}{8}$
- 2 $\frac{8}{6}$
- 3 $\frac{6}{10}$
- 4 $\frac{8}{10}$

A.A.44: USING TRIGONOMETRY TO FIND A SIDE

- 832 In the right triangle shown in the diagram below, what is the value of x to the *nearest whole number*?

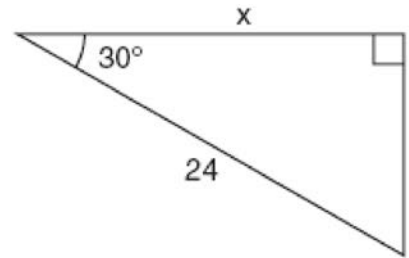

- 1 12
- 2 14
- 3 21
- 4 28

- 833 A stake is to be driven into the ground away from the base of a 50-foot pole, as shown in the diagram below. A wire from the stake on the ground to the top of the pole is to be installed at an angle of elevation of 52° .

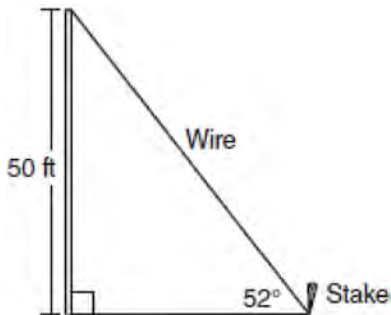

How far away from the base of the pole should the stake be driven in, to the *nearest foot*? What will be the length of the wire from the stake to the top of the pole, to the *nearest foot*?

- 834 A tree casts a 25-foot shadow on a sunny day, as shown in the diagram below.

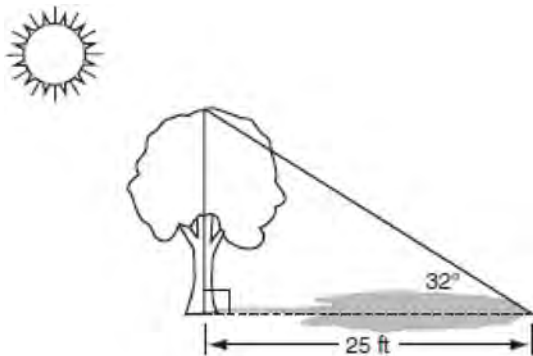

If the angle of elevation from the tip of the shadow to the top of the tree is 32° , what is the height of the tree to the *nearest tenth of a foot*?

- 1 13.2
- 2 15.6
- 3 21.2
- 4 40.0

- 835 A hot-air balloon is tied to the ground with two taut (straight) ropes, as shown in the diagram below. One rope is directly under the balloon and makes a right angle with the ground. The other rope forms an angle of 50° with the ground.

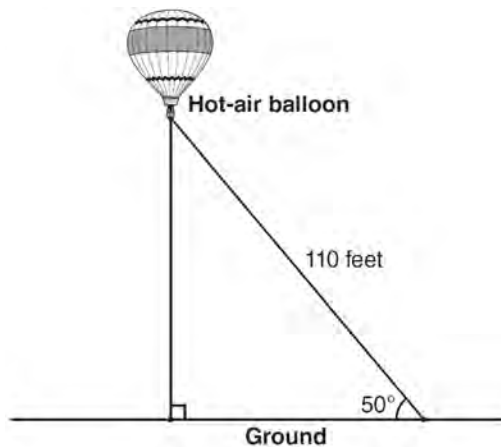

Determine the height, to the *nearest foot*, of the balloon directly above the ground. Determine the distance, to the *nearest foot*, on the ground between the two ropes.

- 836 As shown in the diagram below, a ladder 5 feet long leans against a wall and makes an angle of 65° with the ground. Find, to the *nearest tenth of a foot*, the distance from the wall to the base of the ladder.

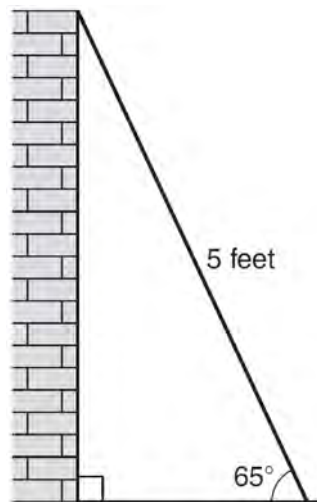

- 837 An 8-foot rope is tied from the top of a pole to a stake in the ground, as shown in the diagram below.

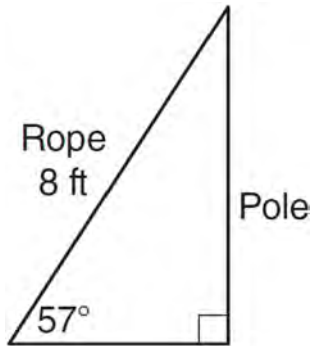

If the rope forms a 57° angle with the ground, what is the height of the pole, to the *nearest tenth of a foot*?

- 1 4.4
 - 2 6.7
 - 3 9.5
 - 4 12.3
- 838 A right triangle contains a 38° angle whose adjacent side measures 10 centimeters. What is the length of the hypotenuse, to the *nearest hundredth of a centimeter*?
- 1 7.88
 - 2 12.69
 - 3 12.80
 - 4 16.24

- 839 A metal pipe is used to hold up a 9-foot fence, as shown in the diagram below. The pipe makes an angle of 48° with the ground.

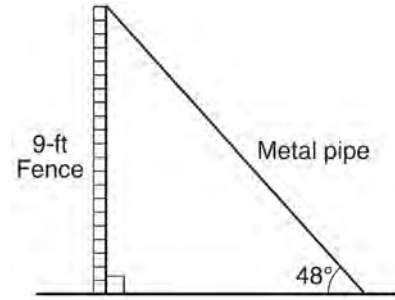

Determine, to the *nearest foot*, how far the bottom of the pipe is from the base of the fence. Determine, to the *nearest foot*, the length of the metal pipe.

- 840 From the top of an apartment building, the angle of depression to a car parked on the street below is 38 degrees, as shown in the diagram below. The car is parked 80 feet from the base of the building. Find the height of the building, to the *nearest tenth of a foot*.

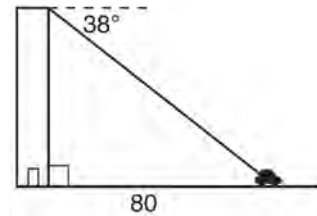

- 841 The top of a lighthouse, T , is 215 feet above sea level, L , as shown in the diagram below. The angle of depression from the top of the lighthouse to a boat, B , at sea is 26° . Determine, to the *nearest foot*, the horizontal distance, x , from the boat to the base of the lighthouse.

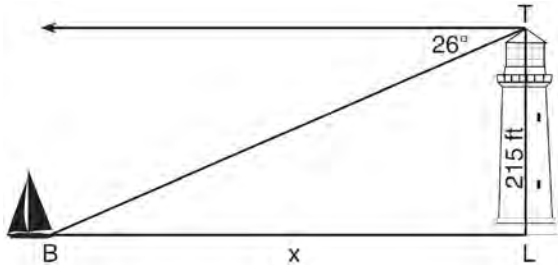

- 842 As shown in the diagram below, a ladder 12 feet long leans against a wall and makes an angle of 72° with the ground.

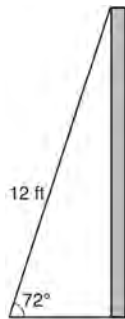

Find, to the *nearest tenth of a foot*, the distance from the wall to the base of the ladder.

- 843 As shown in the diagram below, a building casts a 72-foot shadow on the ground when the angle of elevation of the Sun is 40° .

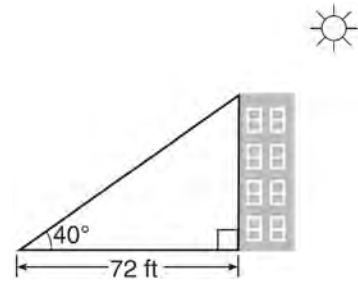

How tall is the building, to the *nearest foot*?

- 1 46
- 2 60
- 3 86
- 4 94

A.A.43: USING TRIGONOMETRY TO FIND AN ANGLE

- 844 The center pole of a tent is 8 feet long, and a side of the tent is 12 feet long as shown in the diagram below.

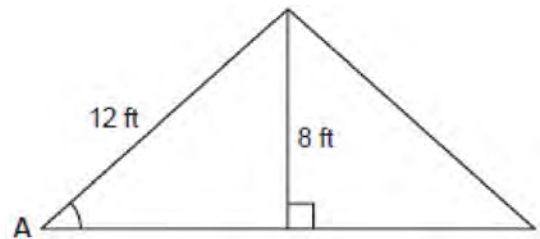

If a right angle is formed where the center pole meets the ground, what is the measure of angle A to the *nearest degree*?

- 1 34
- 2 42
- 3 48
- 4 56

- 845 Which equation could be used to find the measure of one acute angle in the right triangle shown below?

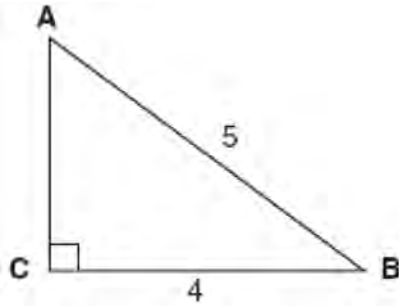

- 1 $\sin A = \frac{4}{5}$
- 2 $\tan A = \frac{5}{4}$
- 3 $\cos B = \frac{5}{4}$
- 4 $\tan B = \frac{4}{5}$

- 846 In the diagram of $\triangle ABC$ shown below, $BC = 10$ and $AB = 16$.

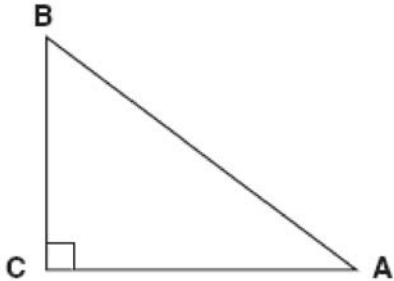

To the *nearest tenth of a degree*, what is the measure of the largest acute angle in the triangle?

- 1 32.0
 - 2 38.7
 - 3 51.3
 - 4 90.0
- 847 In right triangle ABC , $AB = 20$, $AC = 12$, $BC = 16$, and $m\angle C = 90$. Find, to the *nearest degree*, the measure of $\angle A$.

- 848 A communications company is building a 30-foot antenna to carry cell phone transmissions. As shown in the diagram below, a 50-foot wire from the top of the antenna to the ground is used to stabilize the antenna.

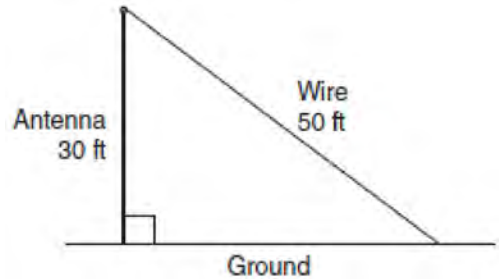

Find, to the *nearest degree*, the measure of the angle that the wire makes with the ground.

- 849 In right triangle ABC shown below, $AB = 18.3$ and $BC = 11.2$.

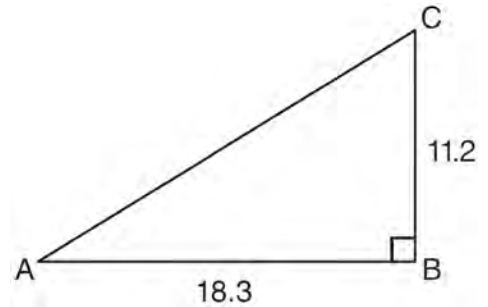

What is the measure of $\angle A$, to the *nearest tenth of a degree*?

- 1 31.5
- 2 37.7
- 3 52.3
- 4 58.5

850 A trapezoid is shown below.

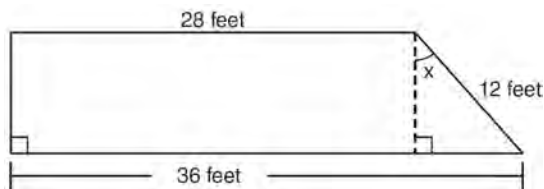

Calculate the measure of angle x , to the *nearest tenth of a degree*.

851 A 28-foot ladder is leaning against a house. The bottom of the ladder is 6 feet from the base of the house. Find the measure of the angle formed by the ladder and the ground, to the *nearest degree*.

852 In right triangle ABC shown below, $AC = 29$ inches, $AB = 17$ inches, and $m\angle ABC = 90$. Find the number of degrees in the measure of angle BAC , to the *nearest degree*.

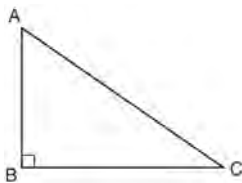

Find the length of \overline{BC} to the *nearest inch*.

853 Which equation could be used to find the measure of angle D in the right triangle shown in the diagram below?

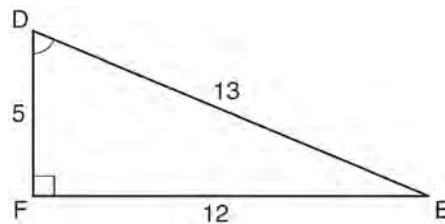

1 $\cos D = \frac{12}{13}$

2 $\cos D = \frac{13}{12}$

3 $\sin D = \frac{5}{13}$

4 $\sin D = \frac{12}{13}$

854 A man standing on level ground is 1000 feet away from the base of a 350-foot-tall building. Find, to the *nearest degree*, the measure of the angle of elevation to the top of the building from the point on the ground where the man is standing.

855 The diagram below shows the path a bird flies from the top of a 9.5-foot-tall sunflower to a point on the ground 5 feet from the base of the sunflower.

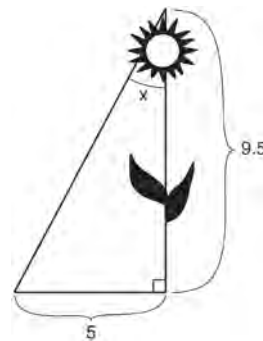

To the *nearest tenth of a degree*, what is the measure of angle x ?

1 27.8

2 31.8

3 58.2

4 62.2

856 In right triangle EFD , $ED = 11$, $EF = 6$, and $m\angle F = 90$. What is the measure of angle E , to the nearest degree?

- 1 61
- 2 57
- 3 33
- 4 29

MEASURING IN THE PLANE AND SPACE

A.G.1: COMPOSITIONS OF POLYGONS AND CIRCLES

857 Serena's garden is a rectangle joined with a semicircle, as shown in the diagram below. Line segment AB is the diameter of semicircle P . Serena wants to put a fence around her garden.

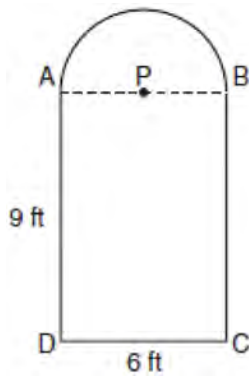

Calculate the length of fence Serena needs to the nearest tenth of a foot.

858 A designer created the logo shown below. The logo consists of a square and four quarter-circles of equal size.

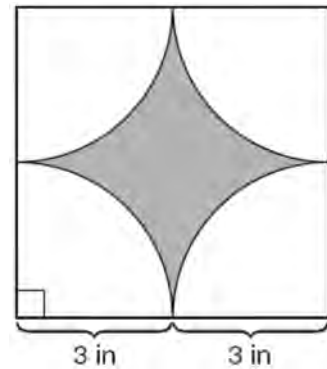

Express, in terms of π , the exact area, in square inches, of the shaded region.

859 Luis is going to paint a basketball court on his driveway, as shown in the diagram below. This basketball court consists of a rectangle and a semicircle.

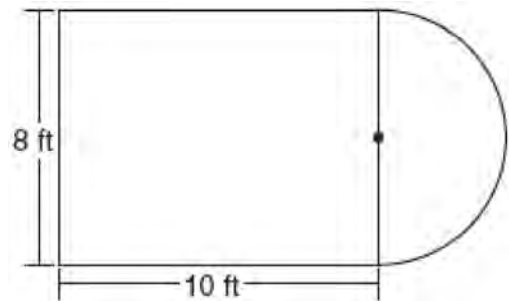

Which expression represents the area of this basketball court, in square feet?

- 1 80
- 2 $80 + 8\pi$
- 3 $80 + 16\pi$
- 4 $80 + 64\pi$

- 860 A window is made up of a single piece of glass in the shape of a semicircle and a rectangle, as shown in the diagram below. Tess is decorating for a party and wants to put a string of lights all the way around the outside edge of the window.

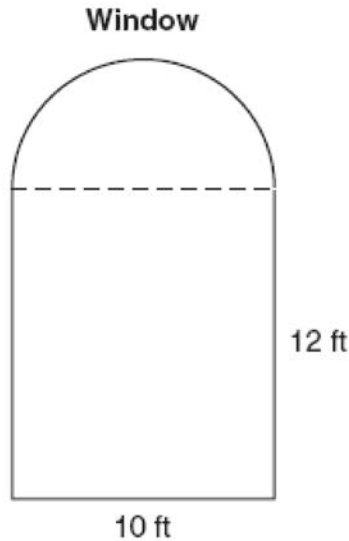

To the *nearest foot*, what is the length of the string of lights that Tess will need to decorate the window?

- 861 In the diagram below, the circumference of circle O is 16π inches. The length of \overline{BC} is three-quarters of the length of diameter \overline{AD} and $CE = 4$ inches. Calculate the area, in square inches, of trapezoid $ABCD$.

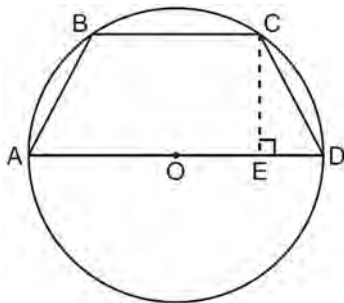

- 862 A playground in a local community consists of a rectangle and two semicircles, as shown in the diagram below.

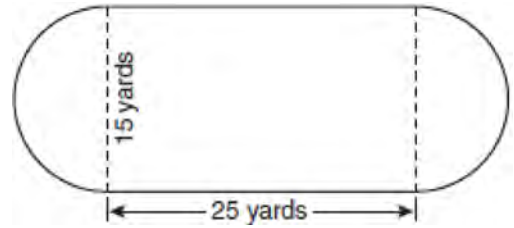

Which expression represents the amount of fencing, in yards, that would be needed to completely enclose the playground?

- 1 $15\pi + 50$
 - 2 $15\pi + 80$
 - 3 $30\pi + 50$
 - 4 $30\pi + 80$
- 863 A figure is made up of a rectangle and a semicircle as shown in the diagram below.

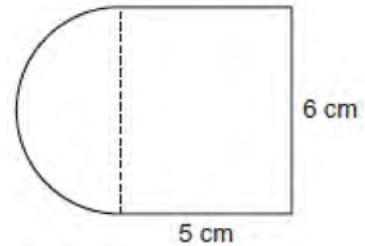

What is the area of the figure, to the *nearest tenth of a square centimeter*?

- 1 39.4
- 2 44.1
- 3 48.8
- 4 58.3

- 864 In the diagram below, $MATH$ is a rectangle, $GB = 4.6$, $MH = 6$, and $HT = 15$.

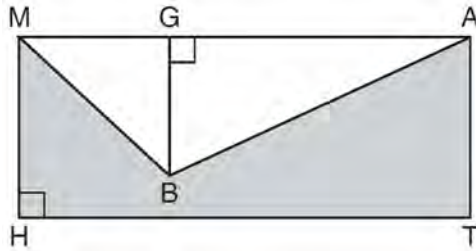

What is the area of polygon $MBATH$?

- 1 34.5
 - 2 55.5
 - 3 90.0
 - 4 124.5
- 865 The figure shown below is composed of two rectangles and a quarter circle.

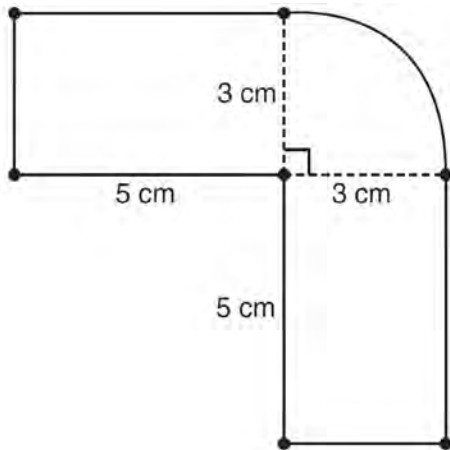

What is the area of this figure, to the nearest square centimeter?

- 1 33
- 2 37
- 3 44
- 4 58

- 866 A garden is in the shape of an isosceles trapezoid and a semicircle, as shown in the diagram below. A fence will be put around the perimeter of the entire garden.

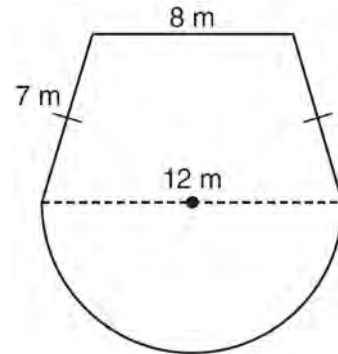

Which expression represents the length of fencing, in meters, that will be needed?

- 1 $22 + 6\pi$
 - 2 $22 + 12\pi$
 - 3 $15 + 6\pi$
 - 4 $15 + 12\pi$
- 867 In the diagram below, circle O is inscribed in square $ABCD$. The square has an area of 36.

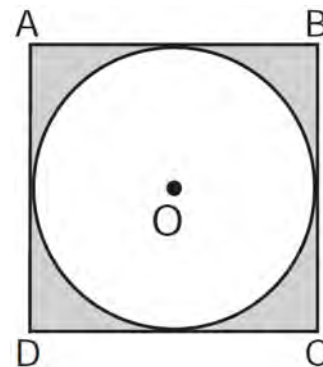

What is the area of the circle?

- 1 9?
- 2 6?
- 3 3?
- 4 36?

- 868 What is the perimeter of the figure shown below, which consists of an isosceles trapezoid and a semicircle?

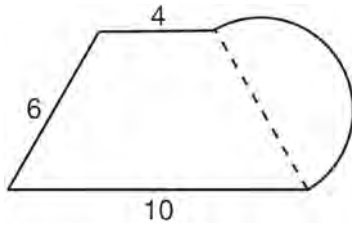

- 1 $20 + 3\pi$
 - 2 $20 + 6\pi$
 - 3 $26 + 3\pi$
 - 4 $26 + 6\pi$
- 869 In the figure below, $ABCD$ is a square and semicircle O has a radius of 6.

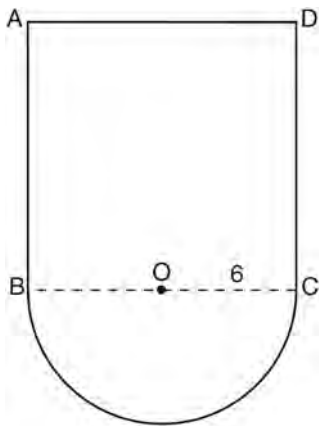

What is the area of the figure?

- 1 $36 + 6\pi$
- 2 $36 + 18\pi$
- 3 $144 + 18\pi$
- 4 $144 + 36\pi$

- 870 In the diagram below of rectangle $AFEB$ and a semicircle with diameter \overline{CD} , $AB = 5$ inches, $AB = BC = DE = FE$, and $CD = 6$ inches. Find the area of the shaded region, to the nearest hundredth of a square inch.

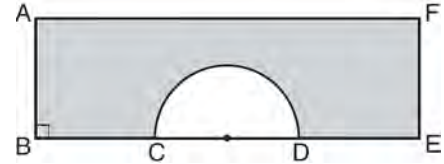

- 871 A designer created a garden, as shown in the diagram below. The garden consists of four quarter-circles of equal size inside a square. The designer put a fence around both the inside and the outside of the garden.

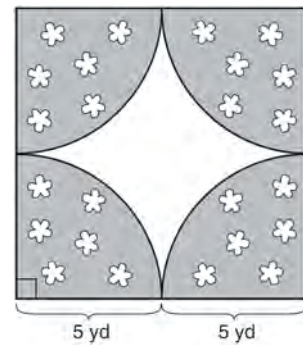

Which expression represents the amount of fencing, in yards, that the designer used for the fence?

- 1 $40 + 10\pi$
- 2 $40 + 25\pi$
- 3 $100 + 10\pi$
- 4 $100 + 25\pi$

- 872 A figure consists of a square and a semicircle, as shown in the diagram below.

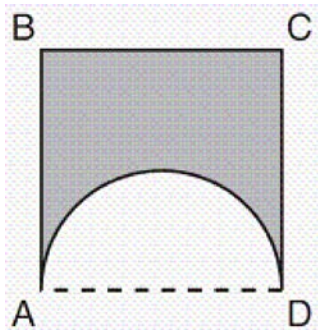

If the length of a side of the square is 6, what is the area of the shaded region?

- 1 $36 - 3\pi$
 - 2 $36 - 4.5\pi$
 - 3 $36 - 6\pi$
 - 4 $36 - 9\pi$
- 873 A patio consisting of two semicircles and a square is shown in the diagram below. The length of each side of the square region is represented by $2x$. Write an expression for the area of the entire patio, in terms of x and π .

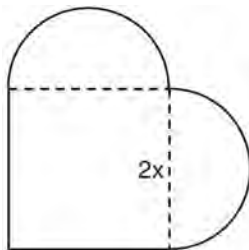

- 874 Ross is installing edging around his pool, which consists of a rectangle and a semicircle, as shown in the diagram below.

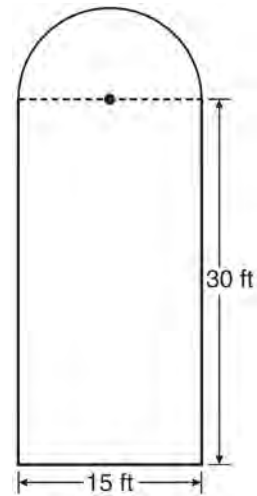

Determine the length of edging, to the *nearest tenth of a foot*, that Ross will need to go completely around the pool.

- 875 The diagram below consists of a square with a side of 4 cm, a semicircle on the top, and an equilateral triangle on the bottom. Find the perimeter of the figure to the *nearest tenth of a centimeter*.

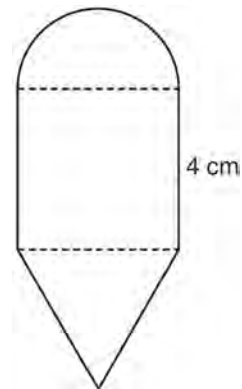

- 876 The Rock Solid Concrete Company has been asked to pave a rectangular area surrounding a circular fountain with a diameter of 8 feet, as shown in the diagram.

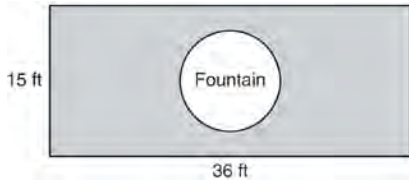

Find the area, to the *nearest square foot*, that must be paved. Find the cost, *in dollars*, of paving the area if the Rock Solid Concrete Company charges \$8.95 per square foot.

- 877 As shown below, polygon $ABCGFED$ consists of two squares, $ABCD$ and $CGFE$, and an equilateral triangle CED . The length of \overline{BC} is $\sqrt{3}$ cm. Determine the perimeter of polygon $ABCGFED$ in radical form.

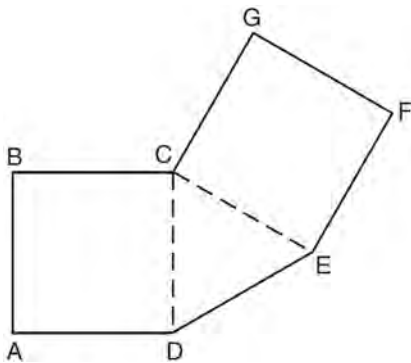

A.G.2: VOLUME

- 878 A cylindrical container has a diameter of 12 inches and a height of 15 inches, as illustrated in the diagram below.

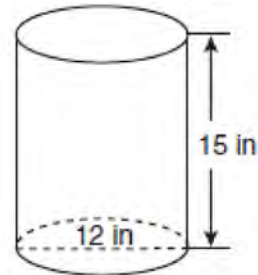

(Not drawn to scale)

What is the volume of this container to the *nearest tenth* of a cubic inch?

- 1 6,785.8
 - 2 4,241.2
 - 3 2,160.0
 - 4 1,696.5
- 879 Lenny made a cube in technology class. Each edge measured 1.5 cm. What is the volume of the cube in cubic centimeters?
- 1 2.25
 - 2 3.375
 - 3 9.0
 - 4 13.5
- 880 A soup can is in the shape of a cylinder. The can has a volume of 342 cm^3 and a diameter of 6 cm. Express the height of the can in terms of π . Determine the maximum number of soup cans that can be stacked on their base between two shelves if the distance between the shelves is exactly 36 cm. Explain your answer.

- 881 The diagram below represents Joe's two fish tanks.

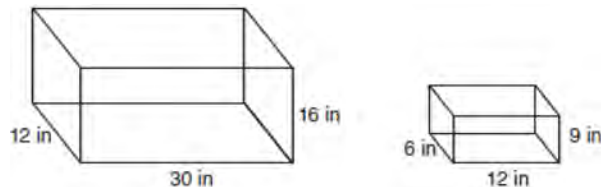

Joe's larger tank is completely filled with water. He takes water from it to completely fill the small tank. Determine how many cubic inches of water will remain in the larger tank.

- 882 A cylinder has a diameter of 10 inches and a height of 2.3 inches. What is the volume of this cylinder, to the *nearest tenth of a cubic inch*?

- 1 72.3
- 2 83.1
- 3 180.6
- 4 722.6

- 883 Mike buys his ice cream packed in a rectangular prism-shaped carton, while Carol buys hers in a cylindrical-shaped carton. The dimensions of the prism are 5 inches by 3.5 inches by 7 inches. The cylinder has a diameter of 5 inches and a height of 7 inches. Which container holds more ice cream? Justify your answer. Determine, to the *nearest tenth of a cubic inch*, how much more ice cream the larger container holds.

- 884 The volume of a cylindrical can is 32π cubic inches. If the height of the can is 2 inches, what is its radius, in inches?

- 1 8
- 2 2
- 3 16
- 4 4

- 885 How many cubes with 5-inch sides will completely fill a cube that is 10 inches on a side?

- 1 50
- 2 25
- 3 8
- 4 4

- 886 Oatmeal is packaged in a cylindrical container, as shown in the diagram below.

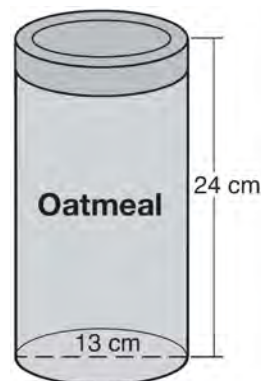

The diameter of the container is 13 centimeters and its height is 24 centimeters. Determine, in terms of π , the volume of the cylinder, in cubic centimeters.

- 887 A thermos in the shape of a cylinder is filled to 1 inch from the top of the cylinder with coffee. The height of the cylinder is 12 inches and its radius is 2.5 inches. State, to the *nearest hundredth of a cubic inch*, the volume of coffee in the thermos.
- 888 A cylinder has a circular base with a radius of 3 units and a height of 7 units. What is the volume of the cylinder in cubic units?
- 1 2π
 - 2 42π
 - 3 63π
 - 4 147π
- 889 A rectangular tank measures 5 feet long, 4 feet wide, and 3 feet high. Water is poured into the tank to a depth of $2\frac{1}{2}$ feet. How many cubic feet of water are in the tank?
- 1 60
 - 2 50
 - 3 15.5
 - 4 11.5

A.G.2: SURFACE AREA

890 Mrs. Ayer is painting the outside of her son's toy box, including the top and bottom. The toy box measures 3 feet long, 1.5 feet wide, and 2 feet high. What is the total surface area she will paint?

- 1 9.0 ft^2
- 2 13.5 ft^2
- 3 22.5 ft^2
- 4 27.0 ft^2

891 How many square inches of wrapping paper are needed to entirely cover a box that is 2 inches by 3 inches by 4 inches?

- 1 18
- 2 24
- 3 26
- 4 52

892 Find the volume, in cubic centimeters, *and* the surface area, in square centimeters, of the rectangular prism shown below.

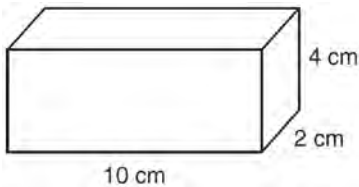

893 A plastic storage box in the shape of a rectangular prism has a length of $x + 3$, a width of $x - 4$, and a height of 5. Represent the surface area of the box as a trinomial in terms of x .

894 The length and width of the base of a rectangular prism are 5.5 cm and 3 cm. The height of the prism is 6.75 cm. Find the *exact* value of the surface area of the prism, in square centimeters.

895 The rectangular prism shown below has a length of 3.0 cm, a width of 2.2 cm, and a height of 7.5 cm.

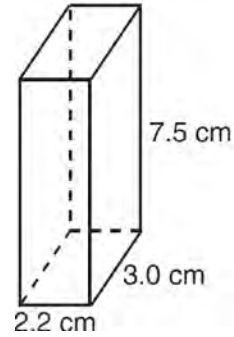

What is the surface area, in square centimeters?

- 1 45.6
- 2 49.5
- 3 78.0
- 4 91.2

896 If the volume of a cube is 8 cubic centimeters, what is its surface area, in square centimeters?

- 1 32
- 2 24
- 3 12
- 4 4

897 The base of a closed right circular cylinder has a diameter of 5 cm. If the height of the cylinder is 8 cm, what is the surface area of the cylinder, to the *nearest square centimeter*?

- 1 157
- 2 165
- 3 408
- 4 628

Integrated Algebra Regents Exam Questions by Performance Indicator: Topic Answer Section

1 ANS: 3

$$|-5(5) + 12| = |-13| = 13$$

PTS: 2 REF: 080923ia STA: A.N.6 TOP: Evaluating Expressions

2 ANS: 1

$$-|a - b| = -|7 - (-3)| = -|-10| = -10$$

PTS: 2 REF: 011010ia STA: A.N.6 TOP: Evaluating Expressions

3 ANS: 2

PTS: 2

REF: 011110ia

STA: A.N.6

TOP: Evaluating Expressions

4 ANS: 1

$$-3(-4)^2(2) + 4(-4) = -96 - 16 = -112$$

PTS: 2 REF: 081113ia STA: A.N.6 TOP: Evaluating Expressions

5 ANS: 1

$$\left| \frac{4(-6) + 18}{4!} \right| = \left| \frac{-6}{24} \right| = \frac{1}{4}$$

PTS: 2 REF: 081220ia STA: A.N.6 TOP: Evaluating Expressions

6 ANS: 2

$$|-3 - 4| - (-3)^2 = 7 - 9 = -2$$

PTS: 2 REF: 011321ia STA: A.N.6 TOP: Evaluating Expressions

7 ANS: 3

$$6! + \frac{5!(3!)}{4!} - 10 = 720 + 5(6) - 10 = 740$$

PTS: 2 REF: 061309ia STA: A.N.6 TOP: Evaluating Expressions

8 ANS: 3

$$2(4)^0 + (4)! = 2 + 24 = 26$$

PTS: 2 REF: 011421ia STA: A.N.6 TOP: Evaluating Expressions

9 ANS: 3

$$3(-3)^2 - 4|-3| + 6 = 27 - 12 + 6 = 21$$

PTS: 2 REF: 061412ia STA: A.N.6 TOP: Evaluating Expressions

10 ANS: 2

PTS: 2

REF: 081402ia

STA: A.N.6

TOP: Evaluating Expressions

11 ANS: 3

PTS: 2

REF: fall0705ia

STA: A.N.1

TOP: Identifying Properties

12 ANS: 2

PTS: 2

REF: 080802ia

STA: A.N.1

TOP: Identifying Properties

- 13 ANS:
(1) Distributive; (2) Commutative
- PTS: 2 REF: 061132ia STA: A.N.1 TOP: Identifying Properties
- 14 ANS: 1 PTS: 2 REF: 081319ia STA: A.N.1
TOP: Identifying Properties
- 15 ANS: 1 PTS: 2 REF: 061405ia STA: A.N.1
TOP: Identifying Properties
- 16 ANS: 3 PTS: 2 REF: 081419ia STA: A.N.1
TOP: Identifying Properties
- 17 ANS: 1 PTS: 2 REF: 061526ia STA: A.N.1
TOP: Identifying Properties
- 18 ANS: 3 PTS: 2 REF: 060926ia STA: A.N.1
TOP: Properties of Reals
- 19 ANS:
 $-6a + 42$. distributive
- PTS: 2 REF: 061032ia STA: A.N.1 TOP: Properties of Reals
- 20 ANS: 4 PTS: 2 REF: 011114ia STA: A.N.1
TOP: Properties of Reals
- 21 ANS: 3 PTS: 2 REF: 011224ia STA: A.N.1
TOP: Properties of Reals
- 22 ANS: 1 PTS: 2 REF: 081209ia STA: A.N.1
TOP: Properties of Reals
- 23 ANS: 3 PTS: 2 REF: 011428ia STA: A.N.1
TOP: Properties of Reals
- 24 ANS: 1 PTS: 2 REF: 011523ia STA: A.N.1
TOP: Properties of Integers
- 25 ANS: 4 PTS: 2 REF: fall0704ia STA: A.A.29
TOP: Set Theory
- 26 ANS: 3 PTS: 2 REF: 010917ia STA: A.A.29
TOP: Set Theory
- 27 ANS: 4 PTS: 2 REF: 060930ia STA: A.A.29
TOP: Set Theory
- 28 ANS: 1 PTS: 2 REF: 061021ia STA: A.A.29
TOP: Set Theory
- 29 ANS: 4 PTS: 2 REF: 081022ia STA: A.A.29
TOP: Set Theory
- 30 ANS: 2 PTS: 2 REF: 011119ia STA: A.A.29
TOP: Set Theory
- 31 ANS: 2 PTS: 2 REF: 061128ia STA: A.A.29
TOP: Set Theory
- 32 ANS: 3 PTS: 2 REF: 081117ia STA: A.A.29
TOP: Set Theory
- 33 ANS: 4 PTS: 2 REF: 011222ia STA: A.A.29
TOP: Set Theory

- 34 ANS: 3 PTS: 2 REF: 061217ia STA: A.A.29
TOP: Set Theory
- 35 ANS: 4 PTS: 2 REF: 011318ia STA: A.A.29
TOP: Set Theory
- 36 ANS: 1 PTS: 2 REF: 061310ia STA: A.A.29
TOP: Set Theory
- 37 ANS: 4 PTS: 2 REF: 081321ia STA: A.A.29
TOP: Set Theory
- 38 ANS: 2 PTS: 2 REF: 061411ia STA: A.A.29
TOP: Set Theory
- 39 ANS: 1 PTS: 2 REF: 081430ia STA: A.A.29
TOP: Set Theory
- 40 ANS: 3 PTS: 2 REF: 061529ia STA: A.A.29
TOP: Set Theory
- 41 ANS: 2
The set of integers greater than -2 and less than 6 is $\{-1, 0, 1, 2, 3, 4, 5\}$. The subset of this set that is the positive factors of 5 is $\{1, 5\}$. The complement of this subset is $\{-1, 0, 2, 3, 4\}$.
- PTS: 2 REF: 060818ia STA: A.A.30 TOP: Set Theory
- 42 ANS:
 $\{1, 2, 4, 5, 9, 10, 12\}$
- PTS: 2 REF: 080833ia STA: A.A.30 TOP: Set Theory
- 43 ANS: 4
 $A = \{2, 4, 6, 8, 10, 12, 14, 16, 18, 20\}$
- PTS: 2 REF: 080912ia STA: A.A.30 TOP: Set Theory
- 44 ANS: 4 PTS: 2 REF: 061001ia STA: A.A.30
TOP: Set Theory
- 45 ANS: 3 PTS: 2 REF: 081009ia STA: A.A.30
TOP: Set Theory
- 46 ANS: 3 PTS: 2 REF: 081103ia STA: A.A.30
TOP: Set Theory
- 47 ANS: 2
 $A = \{4, 9, 16, 25, 36, 49, 64, 81, 100\}$
- PTS: 2 REF: 011326ia STA: A.A.30 TOP: Set Theory
- 48 ANS: 4
 $A = \{1, 3, 5, 7, 9, 11, 13, 15, 17, 19\}$
- PTS: 2 REF: 081306ia STA: A.A.30 TOP: Set Theory
- 49 ANS: 4 PTS: 2 REF: 011426ia STA: A.A.30
TOP: Set Theory
- 50 ANS: 3 PTS: 2 REF: fall0710ia STA: A.A.31
TOP: Set Theory

51 ANS:
 $0 \leq t \leq 40$

PTS: 2 REF: 060833ia STA: A.A.31 TOP: Set Theory

52 ANS: 1 PTS: 2 REF: 011004ia STA: A.A.31
 TOP: Set Theory

53 ANS: 2 PTS: 2 REF: 081003ia STA: A.A.31
 TOP: Set Theory

54 ANS: 1 PTS: 2 REF: 011101ia STA: A.A.31
 TOP: Set Theory

55 ANS: 4 PTS: 2 REF: 061123ia STA: A.A.31
 TOP: Set Theory

56 ANS: 4 PTS: 2 REF: 011225ia STA: A.A.31
 TOP: Set Theory

57 ANS: 3 PTS: 2 REF: 061208ia STA: A.A.31
 TOP: Set Theory

58 ANS: 3
 $A \cup C = \{1, 2, 3, 5, 7, 9\}$

PTS: 2 REF: 081221ia STA: A.A.31 TOP: Set Theory

59 ANS: 3 PTS: 2 REF: 061324ia STA: A.A.31
 TOP: Set Theory

60 ANS: 4 PTS: 2 REF: 061426ia STA: A.A.31
 TOP: Set Theory

61 ANS: 4 PTS: 2 REF: 081408ia STA: A.A.31
 TOP: Set Theory

62 ANS: 2 PTS: 2 REF: 011501ia STA: A.A.31
 TOP: Set Theory

63 ANS: 3 PTS: 2 REF: 061501ia STA: A.A.31
 TOP: Set Theory

64 ANS:

Interval	Tally	Frequency
0-1		3
2-3		7
4-5		7
6-7		3

Interval	Cumulative Frequency
0-1	3
0-3	10
0-5	17
0-7	20

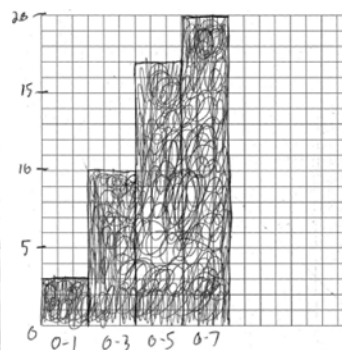

PTS: 4 REF: 080838ia STA: A.S.5
 TOP: Frequency Histograms, Bar Graphs and Tables

KEY: cumulative frequency histograms

65 ANS:

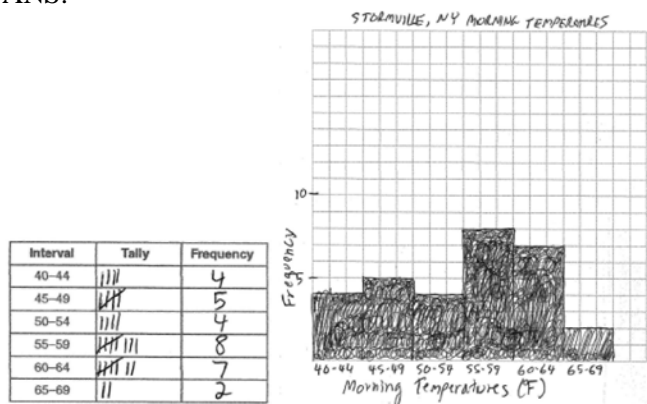

PTS: 4 REF: 060938ia STA: A.S.5
 TOP: Frequency Histograms, Bar Graphs and Tables

KEY: frequency histograms

66 ANS:

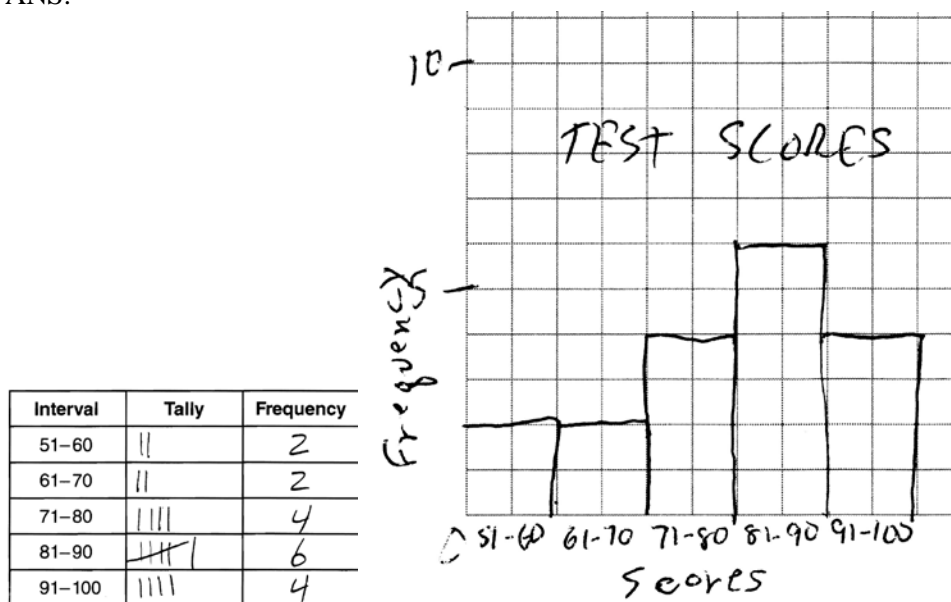

PTS: 3 REF: 011135ia STA: A.S.5
 TOP: Frequency Histograms, Bar Graphs and Tables

KEY: frequency histograms

67 ANS:

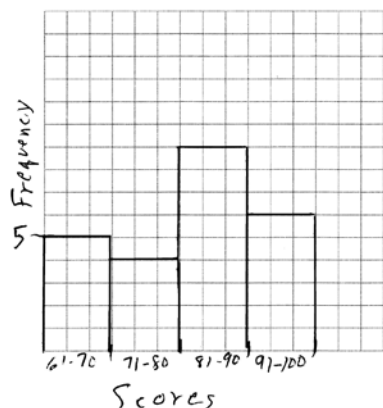

PTS: 2 REF: 081132ia STA: A.S.5

TOP: Frequency Histograms, Bar Graphs and Tables

KEY: frequency histograms

68 ANS: 4 PTS: 2 REF: 011530ia

STA: A.S.5

TOP: Frequency Histograms, Bar Graphs and Tables

69 ANS:

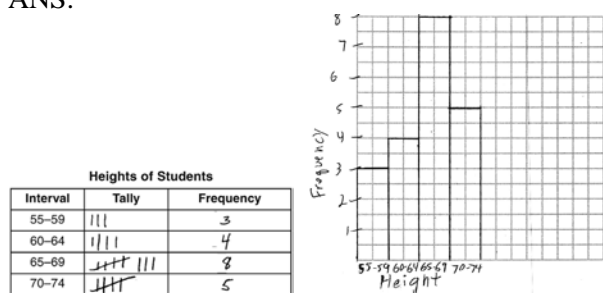

PTS: 3 REF: 061536ia STA: A.S.5

TOP: Frequency Histograms, Bar Graphs and Tables

KEY: frequency histograms

70 ANS: 3

$25 - 18 = 7$

PTS: 2 REF: 060822ia STA: A.S.9

TOP: Frequency Histograms, Bar Graphs and Tables

71 ANS:

30, 20, 71-80, 81-90 and 91-100

PTS: 4 REF: 061038ia STA: A.S.9

TOP: Frequency Histograms, Bar Graphs and Tables

72 ANS: 3 PTS: 2 REF: 061230ia

STA: A.S.9

TOP: Frequency Histograms, Bar Graphs and Tables

73 ANS:

3, 0, 20. $15 - 12 = 3$. $12 - 12 = 0$

PTS: 3 REF: 081234ia STA: A.S.9

TOP: Frequency Histograms, Bar Graphs and Tables

74 ANS:

If there are 31 students, the 16th student's time represents the median. The 16th time is in the 41-80 interval on the cumulative frequency table and the 71-80 interval on the related frequency table.

PTS: 2 REF: 011432ia STA: A.S.9
TOP: Frequency Histograms, Bar Graphs and Tables

75 ANS: 2

The median score, 10, is the vertical line in the center of the box.

PTS: 2 REF: fall0709ia STA: A.S.5 TOP: Box-and-Whisker Plots

76 ANS:

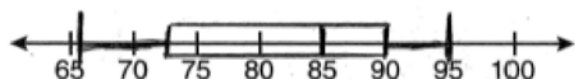

PTS: 4 REF: 080939ia STA: A.S.5 TOP: Box-and-Whisker Plots

77 ANS:

minimum is 120, 1st quartile is 145, median is 292, 3rd quartile is 407, and maximum is 452

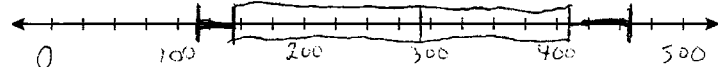

PTS: 3 REF: 081034ia STA: A.S.5 TOP: Box-and-Whisker Plots

78 ANS:

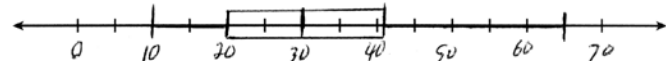

. Three scores are above 41.

PTS: 4 REF: 011337ia STA: A.S.5 TOP: Box-and-Whisker Plots

79 ANS:

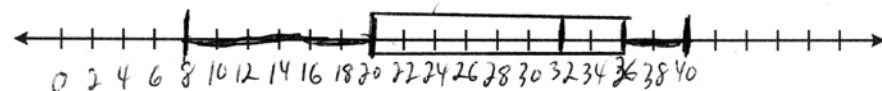

Min: 8, Q1: 20, Med: 32, Q3: 36, Max: 40

PTS: 4 REF: 061439ia STA: A.S.5 TOP: Box-and-Whisker Plots

80 ANS:

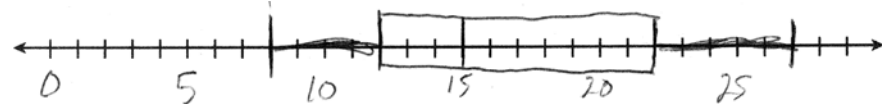

PTS: 2 REF: 081431ia STA: A.S.5 TOP: Box-and-Whisker Plots

81 ANS: 3

The value of the third quartile is the last vertical line of the box.

PTS: 2 REF: 080818ia STA: A.S.6 TOP: Box-and-Whisker Plots

82 ANS: 4

PTS: 2 REF: 010929ia STA: A.S.6
TOP: Box-and-Whisker Plots

- 83 ANS: 3
The value of the upper quartile is the last vertical line of the box.
- PTS: 2 REF: 060915ia STA: A.S.6 TOP: Box-and-Whisker Plots
- 84 ANS: 1 PTS: 2 REF: 011001ia STA: A.S.6
TOP: Box-and-Whisker Plots
- 85 ANS: 3
 $75 - 15 = 60$
- PTS: 2 REF: 011113ia STA: A.S.6 TOP: Box-and-Whisker Plots
- 86 ANS: 2 PTS: 2 REF: 081106ia STA: A.S.6
TOP: Box-and-Whisker Plots
- 87 ANS: 3 PTS: 2 REF: 011220ia STA: A.S.6
TOP: Box-and-Whisker Plots
- 88 ANS: 2 PTS: 2 REF: 061314ia STA: A.S.6
TOP: Box-and-Whisker Plots
- 89 ANS: 4 PTS: 2 REF: 081312ia STA: A.S.6
TOP: Box-and-Whisker Plots
- 90 ANS: 3 PTS: 2 REF: 011408ia STA: A.S.6
TOP: Box-and-Whisker Plots
- 91 ANS: 2 PTS: 2 REF: 011512ia STA: A.S.6
TOP: Box-and-Whisker Plots
- 92 ANS: 3 PTS: 2 REF: 061017ia STA: A.S.11
TOP: Quartiles and Percentiles
- 93 ANS: 4
 $\frac{95000}{125000} = .76$
- PTS: 2 REF: 061207ia STA: A.S.11 TOP: Quartiles and Percentiles
- 94 ANS: 1
 $25\% \times 40 = 10$
- PTS: 2 REF: 011515ia STA: A.S.11 TOP: Quartiles and Percentiles
- 95 ANS: 2 PTS: 2 REF: fall0701ia STA: A.S.7
TOP: Scatter Plots
- 96 ANS: 3 PTS: 2 REF: 081001ia STA: A.S.7
TOP: Scatter Plots
- 97 ANS: 2 PTS: 2 REF: 061115ia STA: A.S.7
TOP: Scatter Plots

98 ANS: 4



PTS: 2

REF: 080822ia

STA: A.S.8

TOP: Scatter Plots

99 ANS:

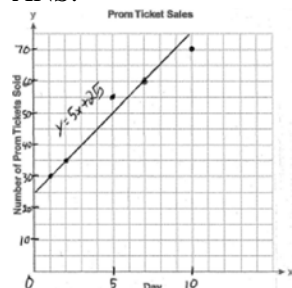

PTS: 3

REF: 060936ia

STA: A.S.8

TOP: Scatter Plots

100 ANS: 4

PTS: 2

REF: 011229ia

STA: A.S.8

TOP: Scatter Plots

101 ANS: 4

PTS: 2

REF: 060805ia

STA: A.S.12

TOP: Scatter Plots

102 ANS: 2

PTS: 2

REF: 011019ia

STA: A.S.12

TOP: Scatter Plots

103 ANS: 3

PTS: 2

REF: 011103ia

STA: A.S.12

TOP: Scatter Plots

104 ANS: 1

PTS: 2

REF: 081102ia

STA: A.S.12

TOP: Scatter Plots

105 ANS: 2

PTS: 2

REF: 061205ia

STA: A.S.12

TOP: Scatter Plots

106 ANS: 1

PTS: 2

REF: 081204ia

STA: A.S.12

TOP: Scatter Plots

107 ANS: 1

PTS: 2

REF: 011301ia

STA: A.S.12

TOP: Scatter Plots

108 ANS: 1

PTS: 2

REF: 081301ia

STA: A.S.12

TOP: Scatter Plots

109 ANS: 4

PTS: 2

REF: 081412ia

STA: A.S.12

TOP: Scatter Plots

110 ANS: 3

PTS: 2

REF: 061512ia

STA: A.S.12

TOP: Scatter Plots

111 ANS: 2

PTS: 2

REF: 080930ia

STA: A.S.17

TOP: Scatter Plots

112 ANS:

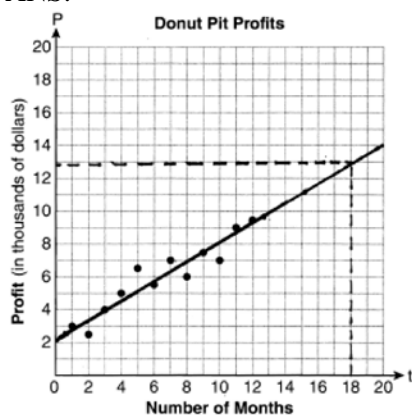

They will not reach their goal in 18 months.

PTS: 3 REF: 061036ia STA: A.S.17 TOP: Scatter Plots

113 ANS: 3 PTS: 2 REF: 081208ia STA: A.S.17

TOP: Scatter Plots

114 ANS: 3 PTS: 2 REF: 061303ia STA: A.S.17

TOP: Scatter Plots

115 ANS: 2 PTS: 2 REF: 011411ia STA: A.S.17

TOP: Scatter Plots

116 ANS:

225000, 175000, the median better represents the value since it is closer to more values than the mean.

PTS: 4 REF: fall0737ia STA: A.S.4

TOP: Frequency Histograms, Bar Graphs and Tables

117 ANS:

315,000, 180,000, the median better represents value since it is closer to more prices than the mean.

PTS: 4 REF: 060839ia STA: A.S.4

TOP: Frequency Histograms, Bar Graphs and Tables

118 ANS: 3

mean = 6, median = 6 and mode = 7

PTS: 2 REF: 080804ia STA: A.S.4 TOP: Central Tendency

119 ANS: 4

The mean is $80.\bar{6}$, the median is 84.5 and the mode is 87.

PTS: 2 REF: 010907ia STA: A.S.4 TOP: Central Tendency

120 ANS: 3

mean = $81\frac{7}{11}$, median = 81 and mode = 76

PTS: 2 REF: 011118ia STA: A.S.4 TOP: Central Tendency

121 ANS: 2

mean = 7, median = 6 and mode = 6

PTS: 2 REF: 011329ia STA: A.S.4 TOP: Central Tendency

- 122 ANS: 1
The mean is 17, the median is 18 and the mode is 22.
- PTS: 2 REF: 081421ia STA: A.S.4 TOP: Central Tendency
- 123 ANS: 3
The mean is 86, the median is 88 and the mode is 92.
- PTS: 2 REF: 061525ia STA: A.S.4 TOP: Central Tendency
- 124 ANS:
81.3, 80, both increase
- PTS: 3 REF: 011035ia STA: A.S.16 TOP: Central Tendency
- 125 ANS:
12, 7. Both the median and the mode will increase.
- PTS: 3 REF: 061134ia STA: A.S.16 TOP: Central Tendency
- 126 ANS: 2 PTS: 2 REF: 081327ia STA: A.S.16
TOP: Central Tendency
- 127 ANS: 4
$$\frac{2+3+0+1+3+2+4+0+2+3}{10} = \frac{20}{10} = 2 \quad \frac{x}{10} = 2 + 0.5$$
$$x = 25$$
- PTS: 2 REF: 081020ia STA: A.S.16 TOP: Average Known with Missing Data
- 128 ANS:
$$\frac{76+84+x+74+91}{5} = 82 \quad 85 - 69 = 16$$
$$x + 325 = 410$$
$$x = 85$$
- PTS: 3 REF: 011535ia STA: A.S.16 TOP: Average Known with Missing Data
- 129 ANS: 3
The other situations are quantitative.
- PTS: 2 REF: 060819ia STA: A.S.1 TOP: Analysis of Data
- 130 ANS: 3
The other situations are quantitative.
- PTS: 2 REF: 060905ia STA: A.S.1 TOP: Analysis of Data
- 131 ANS: 4
The other sets of data are qualitative.
- PTS: 2 REF: 011116ia STA: A.S.1 TOP: Analysis of Data
- 132 ANS: 4
The other situations are quantitative.
- PTS: 2 REF: 081122ia STA: A.S.1 TOP: Analysis of Data

- 133 ANS: 2
The other sets of data are qualitative.
- PTS: 2 REF: 011211ia STA: A.S.1 TOP: Analysis of Data
- 134 ANS: 3
The other situations are qualitative.
- PTS: 2 REF: 081213ia STA: A.S.1 TOP: Analysis of Data
- 135 ANS: 1
The other situations are quantitative.
- PTS: 2 REF: 061308ia STA: A.S.1 TOP: Analysis of Data
- 136 ANS: 3
The other situations are quantitative.
- PTS: 2 REF: 081313ia STA: A.S.1 TOP: Analysis of Data
- 137 ANS: 3
The other situations are qualitative.
- PTS: 2 REF: 011414ia STA: A.S.1 TOP: Analysis of Data
- 138 ANS: 3
The other situations are quantitative.
- PTS: 2 REF: 061402ia STA: A.S.1 TOP: Analysis of Data
- 139 ANS: 4
The other situations are quantitative.
- PTS: 2 REF: 081407ia STA: A.S.1 TOP: Analysis of Data
- 140 ANS: 1
The other situations are quantitative.
- PTS: 2 REF: 061522ia STA: A.S.1 TOP: Analysis of Data
- 141 ANS: 2
The two values are shoe size and height.
- PTS: 2 REF: fall0714ia STA: A.S.2 TOP: Analysis of Data
- 142 ANS: 3
Frequency is not a variable.
- PTS: 2 REF: 011014ia STA: A.S.2 TOP: Analysis of Data
- 143 ANS: 3 PTS: 2 REF: 061011ia STA: A.S.2
TOP: Analysis of Data
- 144 ANS: 3 PTS: 2 REF: 061206ia STA: A.S.2
TOP: Analysis of Data
- 145 ANS: 3
Due to lack of specificity in the wording, this 13th question was removed from the June, 2013 Regents Exam.
- PTS: 2 REF: 061313ia STA: A.S.2 TOP: Analysis of Data

- 146 ANS: 4 PTS: 2 REF: 011504ia STA: A.S.2
TOP: Analysis of Data
- 147 ANS: 4 PTS: 2 REF: 061510ia STA: A.S.2
TOP: Analysis of Data
- 148 ANS: 1
To determine student interest, survey the widest range of students.
- PTS: 2 REF: 060803ia STA: A.S.3 TOP: Analysis of Data
- 149 ANS: 1
Everyone eats, can shop in malls and wear clothes. People who work in a sporting goods store probably watch more sports television than most.
- PTS: 2 REF: 010923ia STA: A.S.3 TOP: Analysis of Data
- 150 ANS: 4
Surveying persons leaving a football game about a sports budget contains the most bias.
- PTS: 2 REF: 080910ia STA: A.S.3 TOP: Analysis of Data
- 151 ANS: 4 PTS: 2 REF: 061022ia STA: A.S.3
TOP: Analysis of Data
- 152 ANS: 1
Asking school district employees about a school board candidate produces the most bias.
- PTS: 2 REF: 061107ia STA: A.S.3 TOP: Analysis of Data
- 153 ANS: 2
People at a gym or football game and members of a soccer team are more biased towards sports.
- PTS: 2 REF: 061202ia STA: A.S.3 TOP: Analysis of Data
- 154 ANS: 2
To determine student opinion, survey the widest range of students.
- PTS: 2 REF: 011313ia STA: A.S.3 TOP: Analysis of Data
- 155 ANS: 3 PTS: 2 REF: 011404ia STA: A.S.3
TOP: Analysis of Data
- 156 ANS: 4 PTS: 2 REF: 061407ia STA: A.S.3
TOP: Analysis of Data
- 157 ANS: 3
The number of correct answers on a test causes the test score.
- PTS: 2 REF: 080908ia STA: A.S.13 TOP: Analysis of Data
- 158 ANS: 2 PTS: 2 REF: 081104ia STA: A.S.13
TOP: Analysis of Data
- 159 ANS: 3 PTS: 2 REF: 081406ia STA: A.S.13
TOP: Analysis of Data
- 160 ANS: 1
A rooster crows before sunrise, not because of the sun.
- PTS: 2 REF: fall0707ia STA: A.S.14 TOP: Analysis of Data

161 ANS: 3

The age of a child does not cause the number of siblings he has, or vice versa.

PTS: 2 REF: 011030ia STA: A.S.14 TOP: Analysis of Data

162 ANS: 3 PTS: 2 REF: 081017a STA: A.S.14

TOP: Analysis of Data

163 ANS: 2 PTS: 2 REF: 061122ia STA: A.S.14

TOP: Analysis of Data

164 ANS: 2 PTS: 2 REF: 061427ia STA: A.S.14

TOP: Analysis of Data

165 ANS: 1 PTS: 2 REF: fall0723ia STA: A.M.3

TOP: Error KEY: area

166 ANS:

618.45, 613.44, 0.008. $21.7 \times 28.5 = 618.45$. $21.6 \times 28.4 = 613.44$. $\left| \frac{618.45 - 613.44}{613.44} \right| \approx 0.008$. An error of less

than 1% would seem to be insignificant.

PTS: 4 REF: 060838ia STA: A.M.3 TOP: Error

KEY: area

167 ANS: 1

$$\left| \frac{289 - 282}{289} \right| \approx 0.024$$

PTS: 2 REF: 080828ia STA: A.M.3 TOP: Error

KEY: volume and surface area

168 ANS:

1,512, 1,551.25, 0.025. $36 \times 42 = 1512$. $36.5 \times 42.5 = 1551.25$. $RE = \left| \frac{1512 - 1551.25}{1551.25} \right| \approx 0.025$.

PTS: 3 REF: 010934ia STA: A.M.3 TOP: Error

KEY: area

169 ANS: 2

The volume of the cube using Ezra's measurements is 8 (2^3). The actual volume is 9.261 (2.1^3). The relative error

$$\text{is } \left| \frac{9.261 - 8}{9.261} \right| \approx 0.14.$$

PTS: 2 REF: 060928ia STA: A.M.3 TOP: Error

KEY: volume and surface area

170 ANS: 2

$$\left| \frac{149.6 - 174.2}{149.6} \right| \approx 0.1644$$

PTS: 2 REF: 080926ia STA: A.M.3 TOP: Error

KEY: area

171 ANS:

$$0.102. \frac{(5.3 \times 8.2 \times 4.1) - (5 \times 8 \times 4)}{5.3 \times 8.2 \times 4.1} = \frac{178.16 - 160}{178.16} = 0.102$$

PTS: 3 REF: 011036ia STA: A.M.3 TOP: Error

KEY: volume and surface area

172 ANS:

$$\frac{600 - 592}{592} \approx 0.014$$

PTS: 2 REF: 061031ia STA: A.M.3 TOP: Error

KEY: volume and surface area

173 ANS: 2

$$\left| \frac{55.42 - 50.27}{55.42} \right| \approx 0.093$$

PTS: 2 REF: 081023ia STA: A.M.3 TOP: Error

KEY: area

174 ANS:

$$0.029. \frac{[2\pi(5.1)^2 + 2\pi(5.1)(15.1)] - [2\pi(5)^2 + 2\pi(5)(15)]}{2\pi(5.1)^2 + 2\pi(5.1)(15.1)} \approx \frac{647.294 - 628.319}{647.294} \approx 0.029$$

PTS: 4 REF: 011137ia STA: A.M.3 TOP: Error

KEY: volume and surface area

175 ANS: 3

$$\frac{(12.3 \times 11.9) - (12.2 \times 11.8)}{12.3 \times 11.9} \approx 0.0165$$

PTS: 2 REF: 061120ia STA: A.M.3 TOP: Error

KEY: area

176 ANS: 2

$$\left| \frac{13.5 - 12.8}{13.5} \right| \approx 0.093$$

PTS: 2 REF: 081123ia STA: A.M.3 TOP: Error

KEY: area

177 ANS: 2

$$\left| \frac{(2.6 \times 6.9) - (2.5 \times 6.8)}{(2.6 \times 6.9)} \right| \approx 0.052$$

PTS: 2 REF: 011209ia STA: A.M.3 TOP: Error

KEY: area

178 ANS:

$$\frac{8100 - 7678.5}{7678.5} \approx 0.055$$

PTS: 2 REF: 061233ia STA: A.M.3 TOP: Error
KEY: area

179 ANS:

$$\frac{(5.9 \times 10.3 \times 1.7) - (6 \times 10 \times 1.5)}{5.9 \times 10.3 \times 1.7} \approx 0.129$$

PTS: 3 REF: 081235ia STA: A.M.3 TOP: Error
KEY: volume and surface area

180 ANS:

$$\left| \frac{(24.2 \times 14.1) - (24 \times 14)}{(24.2 \times 14.1)} \right| = \frac{5.22}{341.22} \approx 0.015$$

PTS: 3 REF: 011336ia STA: A.M.3 TOP: Error
KEY: area

181 ANS:

$$\frac{(10.75)(12.5) - (10.5)(12.25)}{(10.75)(12.5)} \approx 0.043$$

PTS: 3 REF: 081336ia STA: A.M.3 TOP: Error
KEY: area

182 ANS:

$$\frac{6(5.2)^2 - 6(5)^2}{6(5.2)^2} \approx .075$$

PTS: 3 REF: 011435ia STA: A.M.3 TOP: Error
KEY: volume and surface area

183 ANS:

$$\frac{(11.75 \times 7.75 \times 4) - (12 \times 8 \times 4)}{11.75 \times 7.75 \times 4} = \frac{364.25 - 384}{364.25} = 0.054$$

PTS: 3 REF: 061435ia STA: A.M.3 TOP: Error
KEY: volume and surface area

184 ANS:

$$\text{Machine A. } A: \frac{4^2 - 3.97^2}{4^2} \approx .0149 \quad B: \frac{4.12^2 - 4^2}{4^2} \approx .0609$$

PTS: 4 REF: 081438ia STA: A.M.3 TOP: Error
KEY: area

185 ANS:

$$\left| \frac{(36.5 \times 42.5) - (36 \times 42)}{(36.5 \times 42.5)} \right| = \frac{39.25}{1551.25} \approx 0.025$$

PTS: 3 REF: 061535ia STA: A.M.3 TOP: Error

KEY: area

186 ANS:

(S,S), (S,K), (**S,D**), (K,S), (K,K), (**K,D**), (**D,S**), (**D,K**), (D,D), $\frac{4}{9}$

PTS: 3 REF: fall0736ia STA: A.S.19 TOP: Sample Space

187 ANS:

(H,F,M), (H,F,J), (H,F,S), (H,A,M), (H,A,J), (H,A,S), (C,F,M), (C,F,J), (C,F,S), (C,A,M), (C,A,J), (C,A,S), (T,F,M), (T,F,J), (T,F,S), (T,A,M), (T,A,J), (T,A,S). There are 18 different kids' meals, 12 do not include juice and 6 include chicken nuggets.

PTS: 4 REF: 010939ia STA: A.S.19 TOP: Sample Space

188 ANS:

 $\frac{3}{8}$. (H,H,H), (H,H,T), (H,T,H), (**H,T,T**), (T,H,H), (**T,H,T**), (**T,T,H**), (T,T,T)

PTS: 2 REF: 080933ia STA: A.S.19 TOP: Sample Space

189 ANS:

(T,J,F), (T,J,N), (T,K,F), (T,K,N), (T,C,F), (T,C,N), (B,J,F), (B,J,N), (B,K,F), (B,K,N), (B,C,F), (B,C,N), (S,J,F), (S,J,N), (S,K,F), (S,K,N), (S,C,F), (S,C,N). 3, 12.

PTS: 4 REF: 061138ia STA: A.S.19 TOP: Sample Space

190 ANS:

(W,H,A), (W,H,S), (W,T,A), (W,T,S), (W,B,A), (W,B,S), (R,H,A), (R,H,S), (R,T,A), (R,T,S), (R,B,A), (R,B,S). 8, 3

PTS: 4 REF: 011238ia STA: A.S.19 TOP: Sample Space

191 ANS:

(C,B,T), (C,B,5), (C,N,T), (C,N,5), (C,2,T), (C,2,5), (F,B,T), (F,B,5), (F,N,T), (F,N,5), (F,2,T), (F,2,5). 1, 2.

PTS: 4 REF: 081237ia STA: A.S.19 TOP: Sample Space

192 ANS:

(1,A), (1,B), (1,C), (3,A), (3,B), (3,C), (5,A), (5,B), (5,C), (7,A), (7,B), (7,C), (9,A), (9,B), (9,C). 6

PTS: 3 REF: 011334ia STA: A.S.19 TOP: Sample Space

193 ANS: 3

(2, T), (4, T), (6, T)

PTS: 2 REF: 081324ia STA: A.S.19 TOP: Sample Space

- 194 ANS:
cap-jacket: TT, TR, TW, BB, BR, BW, RB, RR, RW, GB, GR, GW, 10, 6.
- PTS: 4 REF: 011439ia STA: A.S.19 TOP: Sample Space
- 195 ANS:
 $\frac{3}{8}$. (H,H,H), (H,H,T), (H,T,H), (**H,T,T**), (T,H,H), (**T,H,T**), (**T,T,H**), (T,T,T)
- PTS: 2 REF: 061432ia STA: A.S.19 TOP: Sample Space
- 196 ANS: 1
 $3 \cdot 3 \cdot 3 = 27$
- PTS: 2 REF: 081413ia STA: A.S.19 TOP: Sample Space
- 197 ANS: 2 PTS: 2 REF: 060908ia STA: A.S.21
TOP: Empirical Probability
- 198 ANS: 3
 $\frac{15}{15 + 13 + 12} = \frac{15}{40} = \frac{3}{8}$
- PTS: 2 REF: 061006ia STA: A.S.21 TOP: Experimental Probability
- 199 ANS: 3
 $\frac{3 + 2 + 4 + 3}{20} = \frac{12}{20}$
- PTS: 2 REF: 011129ia STA: A.S.21 TOP: Experimental Probability
- 200 ANS:
 $\frac{6}{25} \cdot \frac{25 - (11 + 5 + 3)}{25}$
- PTS: 2 REF: 011232ia STA: A.S.21 TOP: Experimental Probability
- 201 ANS: 2 PTS: 2 REF: 011415ia STA: A.S.21
TOP: Experimental Probability
- 202 ANS: 2
 $\frac{12 + 20 + 8}{30 + 50 + 20} \cdot 75 = 30$
- PTS: 2 REF: 011528ia STA: A.S.21 TOP: Empirical Probability
- 203 ANS: 3
 $\frac{14}{30 + 28 + 14 + 28} = \frac{14}{100} = \frac{7}{50}$
- PTS: 2 REF: 061502ia STA: A.S.21 TOP: Experimental Probability
- 204 ANS: 2 PTS: 2 REF: 011002ia STA: A.S.20
TOP: Theoretical Probability

205 ANS: 4

$$P(O) = \frac{3}{6}, P(E) = \frac{3}{6}, P(< 6) = \frac{5}{6}, P(> 4) = \frac{2}{6}$$

PTS: 2 REF: 010903ia STA: A.S.22 TOP: Theoretical Probability

206 ANS:

$$\text{orchestra: } \frac{3}{26} > \frac{4}{36}$$

PTS: 2 REF: 011033ia STA: A.S.22 TOP: Theoretical Probability

207 ANS:

Hat A, add 1 not green to Hat A, add 11 green to Hat B, and add none to Hat C.

PTS: 4 REF: 081038ia STA: A.S.22 TOP: Theoretical Probability

208 ANS: 3

$$P(O) = \frac{5}{10}, P(P) = \frac{4}{10}, P(\leq 5) = \frac{6}{10}, P(/3) = \frac{4}{10}$$

PTS: 2 REF: 081125ia STA: A.S.22 TOP: Theoretical Probability

209 ANS:

White. There are 31 white blocks, 30 red blocks and 29 blue blocks.

PTS: 2 REF: 061232ia STA: A.S.22 TOP: Theoretical Probability

210 ANS: 4

$$P(\text{odd}) = \frac{7+14+20}{75} = \frac{41}{75}. P(\text{even}) = \frac{22+6+6}{75} = \frac{34}{75}. P(3 \text{ or less}) = \frac{14+22+7}{75} = \frac{43}{75}.$$

$$P(2 \text{ or } 4) = \frac{22+6}{75} = \frac{28}{75}$$

PTS: 2 REF: 011325ia STA: A.S.22 TOP: Theoretical Probability

211 ANS: 4

TOP: Theoretical Probability

PTS: 2

REF: 081303ia STA: A.S.22

212 ANS: 3

TOP: Theoretical Probability

PTS: 2

REF: fall0702ia STA: A.S.23

KEY: mutually exclusive events

213 ANS: 2

The events are not mutually exclusive: $P(\text{prime}) = \frac{3}{6}, P(\text{even}) = \frac{3}{6}, P(\text{prime AND even}) = \frac{1}{6}$

$$P(\text{prime OR even}) = \frac{3}{6} + \frac{3}{6} - \frac{1}{6} = \frac{5}{6}$$

PTS: 2 REF: 080830ia STA: A.S.23 TOP: Theoretical Probability

KEY: not mutually exclusive events

214 ANS: 3

$$P(S) \cdot P(M) = P(S \text{ and } M)$$

$$\frac{3}{5} \cdot P(M) = \frac{3}{10}$$

$$P(M) = \frac{1}{2}$$

PTS: 2 REF: 081024ia STA: A.S.23 TOP: Theoretical Probability

KEY: independent events

215 ANS:

$$\frac{4}{12} \times \frac{2}{11} \times \frac{1}{10} = \frac{8}{1320} \quad \frac{6}{12} \times \frac{5}{11} \times \frac{4}{10} + \frac{4}{12} \times \frac{3}{11} \times \frac{2}{10} = \frac{120}{1320} + \frac{24}{1320} = \frac{144}{1320}$$

PTS: 4 REF: 081137ia STA: A.S.23 TOP: Theoretical Probability

KEY: dependent events

216 ANS: 2 PTS: 2 REF: 011212ia STA: A.S.23

TOP: Theoretical Probability KEY: independent events

217 ANS: 4 PTS: 2 REF: 081229ia STA: A.S.23

TOP: Theoretical Probability KEY: independent events

218 ANS:

$$\frac{5}{8} \times \frac{3}{7} = \frac{15}{56} \quad \frac{5}{8} \times \frac{4}{7} = \frac{20}{56} \quad \frac{20}{56} + \frac{3}{8} \times \frac{2}{7} = \frac{26}{56}$$

PTS: 4 REF: 061338ia STA: A.S.23 TOP: Theoretical Probability

KEY: dependent events

219 ANS:

$$\frac{12}{20} \times \frac{8}{19} + \frac{8}{20} \times \frac{12}{19} = \frac{192}{380} \quad 1 - P(BB) = 1 - \left(\frac{8}{20} \times \frac{7}{19} \right) = \frac{380}{380} - \frac{56}{380} = \frac{324}{380}$$

PTS: 4 REF: 081339ia STA: A.S.23 TOP: Theoretical Probability

KEY: dependent events

220 ANS:

$$\frac{6}{12} \cdot \frac{5}{11} \cdot \frac{4}{10} = \frac{1}{11}$$

PTS: 3 REF: 081435ia STA: A.S.23 TOP: Theoretical Probability

KEY: dependent events

221 ANS:

$$\frac{1}{3} \times p = \frac{2}{15}$$

$$p = \frac{2}{15} \times \frac{3}{1}$$

$$p = \frac{2}{5}$$

PTS: 2 REF: 011533ia STA: A.S.23 TOP: Theoretical Probability

KEY: independent events

- 222 ANS: 3 PTS: 2 REF: 080907ia STA: A.S.20
TOP: Geometric Probability
- 223 ANS:
 $\frac{1375}{1600} \cdot \frac{40^2 - 15^2}{40^2} = \frac{1375}{1600}$
- PTS: 2 REF: 011132ia STA: A.S.20 TOP: Geometric Probability
- 224 ANS: 3 PTS: 2 REF: 061218ia STA: A.S.20
TOP: Geometric Probability
- 225 ANS: 4
 $P(G \text{ or } W) = \frac{4}{8}, P(G \text{ or } B) = \frac{3}{8}, P(Y \text{ or } B) = \frac{4}{8}, P(Y \text{ or } G) = \frac{5}{8}$
- PTS: 2 REF: 060802ia STA: A.S.22 TOP: Geometric Probability
- 226 ANS: 3
 $P(\text{odd}) = \frac{3}{6}, P(\text{prime}) = \frac{3}{6}, P(\text{perfect square}) = \frac{2}{6}, P(\text{even}) = \frac{3}{6}$
- PTS: 2 REF: 061104ia STA: A.S.22 TOP: Geometric Probability
- 227 ANS:
 $\frac{3}{8} \cdot P(s_1 < 4) \times P(s_2 = \text{back}) = \frac{3}{4} \times \frac{1}{2} = \frac{3}{8}$
- PTS: 2 REF: 080832ia STA: A.S.23 TOP: Geometric Probability
- 228 ANS: 1
 $\frac{1}{8} \times \frac{1}{8} = \frac{1}{64}$
- PTS: 2 REF: 010928ia STA: A.S.23 TOP: Geometric Probability
- 229 ANS:
 $\frac{1}{8}$. After the English and social studies books are taken, 8 books are left and 1 is an English book.
- PTS: 2 REF: 060933ia STA: A.S.18 TOP: Conditional Probability
- 230 ANS: 4 PTS: 2 REF: 011308ia STA: A.S.18
TOP: Conditional Probability
- 231 ANS: 1
 $\frac{20 - 6}{(20 - 6) + 15 + 7 + 8} = \frac{14}{44}$
- PTS: 2 REF: 061302ia STA: A.S.18 TOP: Conditional Probability
- 232 ANS: 3
 $(3 - 1) \times 2 \times 3 = 12$
- PTS: 2 REF: 080905ia STA: A.N.7 TOP: Conditional Probability

- 233 ANS: 4
 $5 \times 2 \times 3 = 30$
- PTS: 2 REF: 061002ia STA: A.N.7 TOP: Multiplication Counting Principle
- 234 ANS:
 $5 \times 3 \times 5 \times 3 = 225$. $1 \times 3 \times 5 \times 3 = 45$. $1 \times 2 \times 5 \times 3 = 30$
- PTS: 4 REF: 061334ia STA: A.N.7 TOP: Multiplication Counting Principle
- 235 ANS: 2 PTS: 2 REF: 061428ia STA: A.N.7
 TOP: Conditional Probability
- 236 ANS: 3 PTS: 2 REF: 060808ia STA: A.N.8
 TOP: Permutations
- 237 ANS: 1
 ${}_4P_4 = 4 \times 3 \times 2 \times 1 = 24$
- PTS: 2 REF: 080816ia STA: A.N.8 TOP: Permutations
- 238 ANS:
 60. ${}_5P_3 = 60$
- PTS: 2 REF: 060931ia STA: A.N.8 TOP: Permutations
- 239 ANS:
 $15,600,000, 4,368,000$. $10 \times 10 \times 10 \times 26 \times 25 \times 24 = 15,600,000$. $10 \times 9 \times 8 \times 26 \times 25 \times 24 = 11,232,000$.
 $15,600,000 - 11,232,000 = 4,368,000$.
- PTS: 4 REF: 011037ia STA: A.N.8 TOP: Permutations
- 240 ANS: 4
 ${}_8P_3 = 336$
- PTS: 2 REF: 061026ia STA: A.N.8 TOP: Permutations
- 241 ANS: 3
 ${}_6P_4 = 360$
- PTS: 2 REF: 081028ia STA: A.N.8 TOP: Permutations
- 242 ANS: 4
 ${}_5P_5 = 5 \times 4 \times 3 \times 2 \times 1 = 120$
- PTS: 2 REF: 061109ia STA: A.N.8 TOP: Permutations
- 243 ANS:
 $26 \times 25 \times 24 \times 23 = 358,800$. $10^6 = 1,000,000$. Use the numeric password since there are over 500,000 employees
- PTS: 4 REF: 061239ia STA: A.N.8 TOP: Permutations
- 244 ANS: 3
 ${}_{18}P_3 = 4896$
- PTS: 2 REF: 061328ia STA: A.N.8 TOP: Permutations

245 ANS: 4
 ${}_7P_1 = 5040$

PTS: 2

REF: 011527ia

STA: A.N.8

TOP: Permutations

Integrated Algebra Regents Exam Questions by Performance Indicator: Topic Answer Section

246	ANS: 4 $25(x - 3) = 25x - 75$			
	PTS: 2	REF: 060823ia	STA: A.A.1	TOP: Expressions
247	ANS: 4 $A = lw = (3w - 7)(w) = 3w^2 - 7w$			
	PTS: 2	REF: 010924ia	STA: A.A.1	TOP: Expressions
248	ANS: 2 TOP: Expressions	PTS: 2	REF: 060904ia	STA: A.A.1
249	ANS: 4 $5(x + 4) = 5x + 20$			
	PTS: 2	REF: 081013ia	STA: A.A.1	TOP: Expressions
250	ANS: 3 TOP: Expressions	PTS: 2	REF: 011104ia	STA: A.A.1
251	ANS: 1 TOP: Expressions	PTS: 2	REF: 081110ia	STA: A.A.1
252	ANS: 3 TOP: Expressions	PTS: 2	REF: 011205ia	STA: A.A.1
253	ANS: 1 TOP: Expressions	PTS: 2	REF: 061204ia	STA: A.A.1
254	ANS: 2 TOP: Expressions	PTS: 2	REF: 081215ia	STA: A.A.1
255	ANS: 1 TOP: Expressions	PTS: 2	REF: 011303ia	STA: A.A.1
256	ANS: 1 TOP: Expressions	PTS: 2	REF: 061301ia	STA: A.A.1
257	ANS: 3 TOP: Expressions	PTS: 2	REF: 061323ia	STA: A.A.1
258	ANS: 2 TOP: Expressions	PTS: 2	REF: 081305ia	STA: A.A.1
259	ANS: 4 $x + x + 2 + x + 4 = 3x + 6$			
	PTS: 2	REF: 011430ia	STA: A.A.1	TOP: Expressions
260	ANS: 3 TOP: Expressions	PTS: 2	REF: 011507ia	STA: A.A.1
261	ANS: 3 TOP: Expressions	PTS: 2	REF: 061519ia	STA: A.A.1
262	ANS: 4 TOP: Expressions	PTS: 2	REF: fall0729ia	STA: A.A.2
263	ANS: 4 TOP: Expressions	PTS: 2	REF: 061016ia	STA: A.A.2

264 ANS: 3 PTS: 2 REF: 061119ia STA: A.A.2
TOP: Expressions

265 ANS: 1 PTS: 2 REF: 011311ia STA: A.A.2
TOP: Expressions

266 ANS:
Not all of the homework problems are equations. The first problem is an expression.

PTS: 2 REF: 080931ia STA: A.A.3 TOP: Expressions
267 ANS: 2 PTS: 2 REF: 011027ia STA: A.A.3
TOP: Expressions

268 ANS: 1 PTS: 2 REF: 081030ia STA: A.A.3
TOP: Expressions

269 ANS: 2 PTS: 2 REF: 061121ia STA: A.A.3
TOP: Expressions

270 ANS: 2 PTS: 2 REF: 011227ia STA: A.A.3
TOP: Expressions

271 ANS: 4 PTS: 2 REF: 011401ia STA: A.A.3
TOP: Expressions

272 ANS: 3 PTS: 2 REF: 061408ia STA: A.A.3
TOP: Expressions

273 ANS: 4 PTS: 2 REF: 011508ia STA: A.A.3
TOP: Expressions

274 ANS:

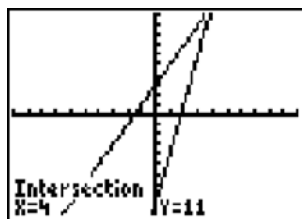

4. $3 + 2g = 5g - 9$

$$12 = 3g$$

$$g = 4$$

PTS: 2 REF: fall0732ia STA: A.A.2 TOP: Solving Equations

275 ANS: 4

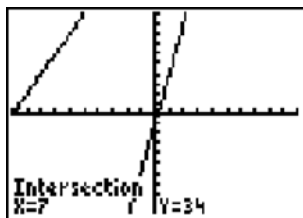

$5p - 1 = 2p + 20$

$$3p = 21$$

$$p = 7$$

PTS: 2 REF: 080801ia STA: A.A.2 TOP: Solving Equations

276 ANS: 2

Debbie failed to distribute the 3 properly.

PTS: 2

REF: 011009ia

STA: A.A.22

TOP: Solving Equations

277 ANS: 1

$$2(x - 4) = 4(2x + 1)$$

$$2x - 8 = 8x + 4$$

$$-12 = 6x$$

$$-2 = x$$

PTS: 2

REF: 011106ia

STA: A.A.22

TOP: Solving Equations

278 ANS:

$$4. 3(x + 1) - 5x = 12 - (6x - 7)$$

$$3x + 3 - 5x = 12 - 6x + 7$$

$$-2x + 3 = -6x + 19$$

$$4x = 16$$

$$x = 4$$

PTS: 4

REF: 061238ia

STA: A.A.22

TOP: Solving Equations

279 ANS: 4

$$5 - 2x = -4x - 7$$

$$2x = -12$$

$$x = -6$$

PTS: 2

REF: 011305ia

STA: A.A.22

TOP: Solving Equations

280 ANS: 2

$$2(x - 4) + 7 = 3$$

$$2x - 8 = -4$$

$$2x = 4$$

$$x = 2$$

PTS: 2

REF: 061425ia

STA: A.A.22

TOP: Solving Equations

281 ANS: 4

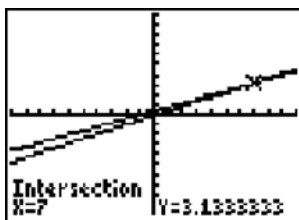

$$\frac{2x}{5} + \frac{1}{3} = \frac{7x-2}{15}$$

$$\frac{(2x \times 3) + (5 \times 1)}{5 \times 3} = \frac{7x-2}{15}$$

$$\frac{6x+5}{15} = \frac{7x-2}{15}$$

$$6x+5 = 7x-2$$

$$x = 7$$

PTS: 2 REF: 080820ia STA: A.A.25

TOP: Solving Equations with Fractional Expressions

282 ANS: 1

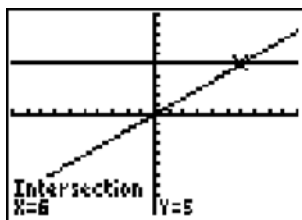

$$\frac{(2x \times 6) + (3 \times x)}{3 \times 6} = 5$$

$$\frac{12x+3x}{18} = 5$$

$$15x = 90$$

$$x = 6$$

PTS: 2 REF: 060907ia STA: A.A.25

TOP: Solving Equations with Fractional Expressions

283 ANS: 2

$$\frac{3}{5}(x+2) = x-4$$

$$3(x+2) = 5(x-4)$$

$$3x+6 = 5x-20$$

$$26 = 2x$$

$$x = 13$$

PTS: 2 REF: 080909ia STA: A.A.25

TOP: Solving Equations with Fractional Expressions

284 ANS: 3

$$\frac{x}{3} + \frac{x+1}{2} = x$$

$$\frac{2x + 3(x+1)}{6} = x$$

$$5x + 3 = 6x$$

$$3 = x$$

PTS: 2 REF: 061019ia STA: A.A.25

TOP: Solving Equations with Fractional Expressions

285 ANS: 1

$$\frac{2x}{3} + \frac{1}{2} = \frac{5}{6}$$

$$\frac{2x}{3} = \frac{1}{3}$$

$$6x = 3$$

$$x = \frac{1}{2}$$

PTS: 2 REF: 011112ia STA: A.A.25

TOP: Solving Equations with Fractional Expressions

286 ANS:

$$\frac{m}{5} + \frac{3(m-1)}{2} = 2(m-3)$$

$$\frac{2m}{10} + \frac{15(m-1)}{10} = 2m - 6$$

$$\frac{17m-15}{10} = 2m-6$$

$$17m-15 = 20m-60$$

$$45 = 3m$$

$$15 = m$$

PTS: 4 REF: 081139ia STA: A.A.25

TOP: Solving Equations with Fractional Expressions

287 ANS: 1

$$\frac{1}{7} + \frac{2x}{3} = \frac{15x-3}{21}$$

$$\frac{14x+3}{21} = \frac{15x-3}{21}$$

$$14x+3 = 15x-3$$

$$x = 6$$

PTS: 2 REF: 011328ia STA: A.A.25

TOP: Solving Equations with Fractional Expressions

288 ANS: 3

$$0.06y + 200 = 0.03y + 350$$

$$0.03y = 150$$

$$y = 5,000$$

PTS: 2 REF: 081203ia STA: A.A.25 TOP: Solving Equations with Decimals

289 ANS: 3

$$0.2(n - 6) = 2.8$$

$$n - 6 = 14$$

$$n = 20$$

PTS: 2 REF: 011502ia STA: A.A.25 TOP: Solving Equations with Decimals

290 ANS: 2

PTS: 2
TOP: Modeling Equations

REF: 080901ia

STA: A.A.4

291 ANS: 3

PTS: 2
TOP: Modeling Equations

REF: 011413ia

STA: A.A.4

292 ANS: 1

PTS: 2
TOP: Modeling Equations

REF: 061418ia

STA: A.A.4

293 ANS: 1

PTS: 2
TOP: Modeling Equations

REF: 061508ia

STA: A.A.4

294 ANS: 4

$$w(w + 5) = 36$$

$$w^2 + 5w - 36 = 0$$

PTS: 2 REF: fall0726ia STA: A.A.5 TOP: Modeling Equations

295 ANS: 2

PTS: 2
TOP: Modeling Equations

REF: 010915ia

STA: A.A.5

296 ANS: 4

PTS: 2
TOP: Modeling Equations

REF: 081011ia

STA: A.A.5

297 ANS: 3

PTS: 2
TOP: Modeling Equations

REF: 061225ia

STA: A.A.5

298 ANS: 3

PTS: 2
TOP: Modeling Equations

REF: 081424ia

STA: A.A.5

299 ANS: 4

Let x = youngest brother and $x + 4$ = oldest brother. $3x - (x + 4) = 48$.

$$2x - 4 = 48$$

$$x = 26$$

PTS: 2 REF: 080928ia STA: A.A.6 TOP: Modeling Equations

300 ANS:

$$7, 9, 11. \quad x + (x + 2) + (x + 4) = 5(x + 2) - 18$$

$$3x + 6 = 5x - 8$$

$$14 = 2x$$

$$7 = x$$

PTS: 4

REF: 011237ia

STA: A.A.6

TOP: Modeling Equations

301 ANS: 4

$$3 + 2 - 1 = 4$$

PTS: 2

REF: 081320ia

STA: A.A.6

TOP: Venn Diagrams

302 ANS: 3

$$3ax + b = c$$

$$3ax = c - b$$

$$x = \frac{c - b}{3a}$$

PTS: 2

REF: 080808ia

STA: A.A.23

TOP: Transforming Formulas

303 ANS: 2

$$P = 2l + 2w$$

$$P - 2l = 2w$$

$$\frac{P - 2l}{2} = w$$

PTS: 2

REF: 010911ia

STA: A.A.23

TOP: Transforming Formulas

304 ANS: 3

$$a + ar = b + r$$

$$a(1 + r) = b + r$$

$$a = \frac{b + r}{1 + r}$$

PTS: 2

REF: 060913ia

STA: A.A.23

TOP: Transforming Formulas

305 ANS: 4

PTS: 2

REF: 011016ia

STA: A.A.23

TOP: Transforming Formulas

306 ANS: 2

PTS: 2

REF: 061023ia

STA: A.A.23

TOP: Transforming Formulas

307 ANS: 4

$$\frac{ey}{n} + k = t$$

$$\frac{ey}{n} = t - k$$

$$y = \frac{n(t-k)}{e}$$

PTS: 2 REF: 011125ia STA: A.A.23 TOP: Transforming Formulas

308 ANS:

$$bc + ac = ab$$

$$c(b + a) = ab$$

$$c = \frac{ab}{b+a}$$

PTS: 2 REF: 081131ia STA: A.A.23 TOP: Transforming Formulas

309 ANS: 1

$$s = \frac{2x+t}{r}$$

$$rs = 2x + t$$

$$rs - t = 2x$$

$$\frac{rs-t}{2} = x$$

PTS: 2 REF: 011228ia STA: A.A.23 TOP: Transforming Formulas

310 ANS: 1

$$k = am + 3mx$$

$$k = m(a + 3x)$$

$$\frac{k}{a+3x} = m$$

PTS: 2 REF: 061215ia STA: A.A.23 TOP: Transforming Formulas

311 ANS: 3

PTS: 2

REF: 081230ia

STA: A.A.23

TOP: Transforming Formulas

312 ANS: 1

$$rx - st = r$$

$$rx = r + st$$

$$x = \frac{r+st}{r}$$

PTS: 2 REF: 061316ia STA: A.A.23 TOP: Transforming Formulas

313 ANS: 2

$$2y + 2w = x$$

$$2w = x - 2y$$

$$w = \frac{x - 2y}{2}$$

PTS: 2

REF: 081330ia

STA: A.A.23

TOP: Transforming Formulas

314 ANS: 1

$$abx - 5 = 0$$

$$abx = 5$$

$$x = \frac{5}{ab}$$

PTS: 2

REF: 011425ia

STA: A.A.23

TOP: Transforming Formulas

315 ANS: 3

$$ax + 3 = 7 - bx$$

$$ax + bx = 4$$

$$x(a + b) = 4$$

$$x = \frac{4}{a + b}$$

PTS: 2

REF: 081426ia

STA: A.A.23

TOP: Transforming Formulas

316 ANS: 4

$$z + y = x(1 + y^2)$$

$$\frac{z + y}{1 + y^2} = x$$

PTS: 2

REF: 061524ia

STA: A.A.23

TOP: Transforming Formulas

317 ANS:

Ann's. $\frac{225}{15} = 15$ mpg is greater than $\frac{290}{23.2} = 12.5$ mpg

PTS: 2

REF: 060831ia

STA: A.M.1

TOP: Using Rate

318 ANS: 3

$$0.75 \text{ hours} = 45 \text{ minutes. } \frac{120}{1} = \frac{x}{45}$$

$$x = 5400$$

PTS: 2

REF: 080814ia

STA: A.M.1

TOP: Using Rate

319 ANS:

$$2,160 \frac{1,200}{25} = \frac{x}{45}$$

$$25x = 54,000$$

$$x = 2,160$$

PTS: 2 REF: 081032ia STA: A.M.1 TOP: Using Rate

320 ANS: 3

$$\frac{120}{60} = \frac{m}{150}$$

$$m = 300$$

PTS: 2 REF: 081202ia STA: A.M.1 TOP: Using Rate

321 ANS: 2

$$\frac{20}{3.98} = \frac{180}{x}$$

$$20x = 716.4$$

$$x = 35.82 \approx 36$$

PTS: 2 REF: 011302ia STA: A.M.1 TOP: Using Rate

322 ANS: 3

$$\frac{15}{2 \times 3} = 2.5$$

PTS: 2 REF: 011509ia STA: A.M.1 TOP: Using Rate

323 ANS:

$$50, 1.5, 10. \frac{\text{distance}}{\text{time}} = \frac{60}{1.2} = 50. \frac{\text{distance}}{\text{time}} = \frac{60}{40} = 1.5. \text{ speed} \times \text{time} = 55 \times 2 = 110. 120 - 110 = 10$$

PTS: 3 REF: fall0734ia STA: A.M.1 TOP: Speed

324 ANS:

$$111.25. \frac{\text{distance}}{\text{time}} = \frac{89}{0.8} = 111.25$$

PTS: 2 REF: 080831ia STA: A.M.1 TOP: Speed

325 ANS: 4

$$\frac{\text{distance}}{\text{time}} = \frac{24}{6} = 4$$

PTS: 2 REF: 010902ia STA: A.M.1 TOP: Speed

326 ANS: 4

$$\frac{5}{45} = \frac{8}{x}$$

$$5x = 360$$

$$x = 72$$

PTS: 2 REF: 060901ia STA: A.M.1 TOP: Speed

327 ANS:

Greg's rate of 5.5 is faster than Dave's rate of 5.3. $\frac{\text{distance}}{\text{time}} = \frac{11}{2} = 5.5$. $\frac{16}{3} = 5.\bar{3}$

PTS: 3 REF: 080936ia STA: A.M.1 TOP: Speed

328 ANS: 4

$$s = \frac{d}{t} = \frac{150 \text{ m}}{1.5 \text{ min}} \cdot \frac{60 \text{ min}}{1 \text{ hr}} = 6,000 \frac{\text{m}}{\text{hr}}$$

PTS: 2 REF: 061025ia STA: A.M.1 TOP: Speed

329 ANS: 1

$$\frac{12.8 + 17.2}{3 + 5} = 3.75$$

PTS: 2 REF: 061117ia STA: A.M.1 TOP: Speed

330 ANS:

The turtle won by .5 minutes. Turtle: $\frac{d}{s} = \frac{100}{20} = 5$. Rabbit: $\frac{d}{s} = \frac{100}{40} = 2.5 + 3 = 5.5$

PTS: 3 REF: 011236ia STA: A.M.1 TOP: Speed

331 ANS: 1

$$\frac{\text{distance}}{\text{time}} = \frac{350.7}{4.2} = 83.5$$

PTS: 2 REF: 061201ia STA: A.M.1 TOP: Speed

332 ANS:

$$t = \frac{d}{s} = \frac{136,000,000}{31,000} \approx 4387.1 \text{ hours. } \frac{4387.1}{24} \approx 183$$

PTS: 2 REF: 061333ia STA: A.M.1 TOP: Speed

333 ANS: 2

$$d = st = 45 \times 3 = 135 \text{ miles. } t = \frac{d}{s} = \frac{135}{55} \approx 2.5 \text{ hours}$$

PTS: 2 REF: 011419ia STA: A.M.1 TOP: Speed

334 ANS: 4

$$\frac{15}{500} = \frac{6}{x}$$

$$15x = 3000$$

$$x = 200$$

PTS: 2 REF: 061403ia STA: A.M.1 TOP: Speed

335 ANS:

$$\frac{\text{distance}}{\text{time}} = \frac{170}{2.75} \approx 61.8$$

PTS: 2 REF: 061531ia STA: A.M.1 TOP: Speed

336 ANS: 3

$$F = \frac{9}{5}C + 32 = \frac{9}{5}(15) + 32 = 59$$

PTS: 2 REF: 010901ia STA: A.M.2 TOP: Conversions

KEY: formula

337 ANS: 4

$$\frac{344 \text{ m}}{\text{sec}} \times \frac{60 \text{ sec}}{1 \text{ min}} \times \frac{60 \text{ min}}{1 \text{ hr}} = 1,238,400 \frac{\text{m}}{\text{hr}}$$

PTS: 2 REF: 060911ia STA: A.M.2 TOP: Conversions

KEY: dimensional analysis

338 ANS:

16. 12 feet equals 4 yards. $4 \times 4 = 16$.

PTS: 2 REF: 011031ia STA: A.M.2 TOP: Conversions

KEY: dimensional analysis

339 ANS:

$$5. 48 \text{ inches} \times \frac{1 \text{ yard}}{36 \text{ inches}} = \frac{4}{3} \text{ yards} \times \$3.75 = \$5.00$$

PTS: 2 REF: 011131ia STA: A.M.2 TOP: Conversions

KEY: dimensional analysis

340 ANS:

$$77120 + 33500 = 110620 \text{ sq. ft.} \times \frac{1 \text{ acre}}{43560 \text{ sq. ft.}} \approx 2.54 \text{ acres}$$

PTS: 2 REF: 081133ia STA: A.M.2 TOP: Conversions

KEY: dimensional analysis

341 ANS: 1

$$\frac{3}{4} \times 5 = \frac{15}{4} \text{ teaspoons} \times \frac{1 \text{ tablespoon}}{3 \text{ teaspoons}} = \frac{5}{4} = 1 \frac{1}{4} \text{ tablespoon}$$

PTS: 2 REF: 061228ia STA: A.M.2 TOP: Conversions

KEY: dimensional analysis

342 ANS: 4

$$8900 \text{ ft} \times \frac{1 \text{ mi}}{5280 \text{ ft}} \approx 1.7 \text{ mi}$$

PTS: 2 REF: 081210ia STA: A.M.2 TOP: Conversions
KEY: dimensional analysis

343 ANS: 3 PTS: 2 REF: 011317ia STA: A.M.2

TOP: Conversions KEY: dimensional analysis

344 ANS: 4

$$5.5 \text{ g} \times \frac{4 \text{ q}}{1 \text{ g}} \times \frac{32 \text{ oz}}{1 \text{ q}} = 704 \text{ oz}$$

PTS: 2 REF: 061305ia STA: A.M.2 TOP: Conversions
KEY: dimensional analysis

345 ANS:

$$\frac{5.4 \text{ miles}}{\text{hour}} \times \frac{5280 \text{ feet}}{\text{mile}} \times \frac{1 \text{ hour}}{60 \text{ min}} = \frac{475.2 \text{ ft}}{\text{min}}$$

PTS: 2 REF: 081331ia STA: A.M.2 TOP: Conversions
KEY: dimensional analysis

346 ANS: 2

$$100 \text{ yd} \cdot \frac{3 \text{ ft}}{1 \text{ yd}} \cdot \frac{3}{4} = 225$$

PTS: 2 REF: 081415ia STA: A.M.2 TOP: Conversions
KEY: dimensional analysis

347 ANS: 4

$$\frac{8000 \text{ mi}}{1 \text{ yr}} \times \frac{1760 \text{ yd}}{1 \text{ mi}} \times \frac{1 \text{ yr}}{365 \text{ d}} \approx 38,575 \text{ yd/d}$$

PTS: 2 REF: 011522ia STA: A.M.2 TOP: Conversions
KEY: dimensional analysis

348 ANS: 1

$$5 \times 16 = 80 \text{ oz. } \frac{1680}{80} = 21$$

PTS: 2 REF: 061521ia STA: A.M.2 TOP: Conversions
KEY: dimensional analysis

349 ANS:

$$\frac{1}{6}, 16.67\%, \$13.50. \frac{18-15}{18} = \frac{1}{6}. 18 \times 0.75 = 13.5$$

PTS: 3 REF: 060835ia STA: A.N.5 TOP: Percents

- 350 ANS:
 30.4%; no, 23.3%. $\frac{7.50 - 5.75}{5.75} = 30.4\%$. $\frac{7.50 - 5.75}{7.50} = 23.3\%$
- PTS: 3 REF: 080935ia STA: A.N.5 TOP: Percents
- 351 ANS: 2
 Candidate *B* received 45%. $45\% \times 1860 = 837$
- PTS: 2 REF: 081007ia STA: A.N.5 TOP: Percents
- 352 ANS:
 $259.99 \times 1.07 - 259.99(1 - 0.3) \times 1.07 = 83.46$
- PTS: 4 REF: 011239ia STA: A.N.5 TOP: Percents
- 353 ANS:
 $800 - (895)(0.75)(1.08) = 75.05$
- PTS: 3 REF: 081334ia STA: A.N.5 TOP: Percents
- 354 ANS:
 $(1 - 0.20)p = 28.80$
 $p = 36$
- PTS: 2 REF: 011532ia STA: A.N.5 TOP: Percents
- 355 ANS:
 $d = 6.25h$, 250. $d = 6.25(40) = 250$
- PTS: 2 REF: 010933ia STA: A.N.5 TOP: Direct Variation
- 356 ANS: 4
 $\frac{150}{20} = \frac{x}{30}$
 $20x = 4500$
 $x = 225$
- PTS: 2 REF: 081101ia STA: A.N.5 TOP: Direct Variation
- 357 ANS: 2
 TOP: Slope
 PTS: 2 REF: 080823ia STA: A.A.32
- 358 ANS: 1
 TOP: Slope
 PTS: 2 REF: 081115ia STA: A.A.32
- 359 ANS: 2
 TOP: Slope
 PTS: 2 REF: 081223ia STA: A.A.32
- 360 ANS: 3
 $m = \frac{4 - 10}{3 - (-6)} = -\frac{2}{3}$
- PTS: 2 REF: fall0716ia STA: A.A.33 TOP: Slope

361 ANS: 3

$$m = \frac{1 - (-4)}{-6 - 4} = -\frac{1}{2}$$

PTS: 2 REF: 060820ia STA: A.A.33 TOP: Slope

362 ANS: 2

$$m = \frac{5 - 3}{2 - 7} = -\frac{2}{5}$$

PTS: 2 REF: 010913ia STA: A.A.33 TOP: Slope

363 ANS: 1

$$m = \frac{4 - (-4)}{-5 - 15} = -\frac{2}{5}$$

PTS: 2 REF: 080915ia STA: A.A.33 TOP: Slope

364 ANS: 4

$$A(-3, 4) \text{ and } B(5, 8). \quad m = \frac{4 - 8}{-3 - 5} = \frac{-4}{-8} = \frac{1}{2}$$

PTS: 2 REF: 011007ia STA: A.A.33 TOP: Slope

365 ANS: 2

$$m = \frac{5 - 2}{3 - (-2)} = \frac{3}{5}$$

PTS: 2 REF: 061004ia STA: A.A.33 TOP: Slope

366 ANS: 2

$$A(-3, 8) \text{ and } B(3, 6). \quad m = \frac{8 - 6}{-3 - 3} = \frac{2}{-6} = -\frac{1}{3}$$

PTS: 2 REF: 081005ia STA: A.A.33 TOP: Slope

367 ANS: 3

$$m = \frac{6 - 4}{3 - (-2)} = \frac{2}{5}$$

PTS: 2 REF: 061110ia STA: A.A.33 TOP: Slope

368 ANS: 4

$$m = \frac{-3 - 1}{2 - 5} = \frac{-4}{-3} = \frac{4}{3}$$

PTS: 2 REF: 011215ia STA: A.A.33 TOP: Slope

369 ANS: 2

$$m = \frac{-7 - 1}{4 - 9} = \frac{-8}{-5} = \frac{8}{5}$$

PTS: 2 REF: 081310ia STA: A.A.33 TOP: Slope

370 ANS: 2

$$m = \frac{-7 - (-2)}{-2 - (-6)} = \frac{-5}{4}$$

PTS: 2 REF: 061410ia STA: A.A.33 TOP: Slope

371 ANS: 2

$$m = \frac{5 - -3}{-7 - 5} = \frac{8}{-12} = -\frac{2}{3}$$

PTS: 2 REF: 081411ia STA: A.A.33 TOP: Slope

372 ANS: 2

$$m = \frac{-A}{B} = \frac{-3}{-7} = \frac{3}{7}$$

PTS: 2 REF: 011122ia STA: A.A.37 TOP: Slope

373 ANS: 4

$$m = \frac{-A}{B} = \frac{-(-3)}{2} = \frac{3}{2}$$

PTS: 2 REF: 061212ia STA: A.A.37 TOP: Slope

374 ANS: 4

$$m = \frac{-A}{B} = \frac{-4}{3}$$

PTS: 2 REF: 061319ia STA: A.A.37 TOP: Slope

375 ANS: 2

$$y = \frac{1}{2}x - 2$$

PTS: 2 REF: 011409ia STA: A.A.37 TOP: Slope

376 ANS: 4

$$m = \frac{-A}{B} = \frac{-4}{3}$$

PTS: 2 REF: 011516ia STA: A.A.37 TOP: Slope

377 ANS: 4

PTS: 2 REF: 061509ia STA: A.A.37
TOP: Slope

378 ANS: 2

If the car can travel 75 miles on 4 gallons, it can travel 300 miles on 16 gallons. $\frac{75}{4} = \frac{x}{16}$.
 $x = 300$

PTS: 2 REF: 080807ia STA: A.G.4 TOP: Graphing Linear Functions

379 ANS: 1

$$y = mx + b$$

$$-6 = (-3)(4) + b$$

$$b = 6$$

PTS: 2

REF: 060922ia

STA: A.A.34

TOP: Writing Linear Equations

380 ANS: 4

$$y = mx + b$$

$$-1 = (2)(3) + b$$

$$b = -7$$

PTS: 2

REF: 080927ia

STA: A.A.34

TOP: Writing Linear Equations

381 ANS:

$$y = \frac{3}{4}x + 10. \quad y = mx + b$$

$$4 = \frac{3}{4}(-8) + b$$

$$4 = -6 + b$$

$$10 = b$$

PTS: 3

REF: 011134ia

STA: A.A.34

TOP: Writing Linear Equations

382 ANS: 1

$$y = mx + b$$

$$5 = (-2)(1) + b$$

$$b = 7$$

PTS: 2

REF: 081108ia

STA: A.A.34

TOP: Writing Linear Equations

383 ANS: 3

$$y = mx + b \quad y = \frac{3}{4}x - \frac{1}{2}$$

$$1 = \left(\frac{3}{4}\right)(2) + b \quad 4y = 3x - 2$$

$$1 = \frac{3}{2} + b$$

$$b = -\frac{1}{2}$$

PTS: 2

REF: 081219ia

STA: A.A.34

TOP: Writing Linear Equations

384 ANS: 1

$$y = mx + b$$

$$-8 = (3)(-2) + b$$

$$b = -2$$

PTS: 2

REF: 011406ia

STA: A.A.34

TOP: Writing Linear Equations

385 ANS: 2

$$y = mx + b$$

$$-7 = \left(-\frac{4}{3}\right)(3) + b$$

$$-7 = -4 + b$$

$$b = -3$$

PTS: 2

REF: 061419ia

STA: A.A.34

TOP: Writing Linear Equations

386 ANS: 1

$$m = \frac{3-0}{0-2} = -\frac{3}{2}. \text{ Using the given y-intercept } (0, 3) \text{ to write the equation of the line } y = -\frac{3}{2}x + 3.$$

PTS: 2

REF: fall0713ia

STA: A.A.35

TOP: Writing Linear Equations

387 ANS:

$$y = \frac{2}{5}x + 2. \quad m = \frac{4-0}{5-(-5)} = \frac{2}{5}. \quad y = mx + b$$

$$4 = \frac{2}{5}(5) + b$$

$$b = 2$$

PTS: 3

REF: 080836ia

STA: A.A.35

TOP: Writing Linear Equations

388 ANS: 3

PTS: 2

REF: 010910ia

STA: A.A.35

TOP: Writing Linear Equations

389 ANS: 3

$$m = \frac{7-3}{-3-3} = \frac{4}{-6} = -\frac{2}{3} \quad y = mx + b$$

$$3 = -\frac{2}{3}(3) + b$$

$$3 = -2 + b$$

$$5 = b$$

PTS: 2

REF: 011013ia

STA: A.A.35

TOP: Writing Linear Equations

390 ANS: 2

$$m = \frac{5-3}{8-1} = \frac{2}{7} \quad y - y_1 = m(x - x_1)$$

$$y - 5 = \frac{2}{7}(x - 8)$$

PTS: 2

REF: 081029ia

STA: A.A.35

TOP: Writing Linear Equations

391 ANS: 2

$$m = \frac{1-7}{1--2} = \frac{-6}{3} = -2 \quad y = mx + b$$

$$1 = -2(1) + b$$

$$3 = b$$

PTS: 2

REF: 081404ia

STA: A.A.35

TOP: Writing Linear Equations

392 ANS: 2

$$m = \frac{1-(-5)}{2-6} = \frac{6}{-4} = -\frac{3}{2} \quad 1 = \left(-\frac{3}{2}\right)(2) + b$$

$$1 = -3 + b$$

$$4 = b$$

PTS: 2

REF: 011510ia

STA: A.A.35

TOP: Writing Linear Equations

393 ANS: 1

$$m = \frac{10--2}{3--1} = \frac{12}{4} = 3 \quad y = mx + b$$

$$10 = 3(3) + b$$

$$10 = 9 + b$$

$$1 = b$$

PTS: 2

REF: 061515ia

STA: A.A.35

TOP: Writing Linear Equations

394 ANS: 1

$$4y - 2x = 0$$

$$4(-1) - 2(-2) = 0$$

$$-4 + 4 = 0$$

PTS: 2

REF: 011021ia

STA: A.A.39

TOP: Identifying Points on a Line

395 ANS: 3

$$2(1) + 3 = 5$$

PTS: 2

REF: 061007ia

STA: A.A.39

TOP: Linear Equations

396 ANS: 4

$$2x - 3y = 9$$

$$2(0) - 3(-3) = 9$$

$$0 + 9 = 9$$

PTS: 2

REF: 081016ia

STA: A.A.39

TOP: Identifying Points on a Line

- 397 ANS: 4
 $3y + 2x = 8$
 $3(-2) + 2(7) = 8$
 $-6 + 14 = 8$
- PTS: 2 REF: 011218ia STA: A.A.39 TOP: Identifying Points on a Line
- 398 ANS: 4
 $2(2) - (-7) = 11$
- PTS: 2 REF: 081217ia STA: A.A.39 TOP: Identifying Points on a Line
- 399 ANS: 3
 $2(5) + k = 9$
 $10 + k = 9$
 $k = -1$
- PTS: 2 REF: 061304ia STA: A.A.39 TOP: Identifying Points on a Line
- 400 ANS: 2 PTS: 2 REF: 080810ia STA: A.A.36
TOP: Parallel and Perpendicular Lines
- 401 ANS: 1 PTS: 2 REF: 080911ia STA: A.A.36
TOP: Parallel and Perpendicular Lines
- 402 ANS: 2 PTS: 2 REF: 081014ia STA: A.A.36
TOP: Parallel and Perpendicular Lines
- 403 ANS: 4 PTS: 2 REF: 061112ia STA: A.A.36
TOP: Parallel and Perpendicular Lines
- 404 ANS: 3 PTS: 2 REF: 011324ia STA: A.A.36
TOP: Parallel and Perpendicular Lines
- 405 ANS: 2 PTS: 2 REF: 061327ia STA: A.A.36
TOP: Parallel and Perpendicular Lines
- 406 ANS: 1 PTS: 2 REF: 061416ia STA: A.A.36
TOP: Parallel and Perpendicular Lines
- 407 ANS: 4 PTS: 2 REF: 081423ia STA: A.A.36
TOP: Parallel and Perpendicular Lines
- 408 ANS: 1 PTS: 2 REF: 061513ia STA: A.A.36
TOP: Parallel and Perpendicular Lines
- 409 ANS: 1
The slope of both is -4 .
- PTS: 2 REF: 060814ia STA: A.A.38 TOP: Parallel and Perpendicular Lines
- 410 ANS: 1
The slope of $y = 3 - 2x$ is -2 . Using $m = -\frac{A}{B}$, the slope of $4x + 2y = 5$ is $-\frac{4}{2} = -2$.
- PTS: 2 REF: 010926ia STA: A.A.38 TOP: Parallel and Perpendicular Lines

411 ANS: 1

The slope of $2x - 4y = 16$ is $\frac{-A}{B} = \frac{-2}{-4} = \frac{1}{2}$

PTS: 2 REF: 011026ia STA: A.A.38 TOP: Parallel and Perpendicular Lines

412 ANS: 2

$y - kx = 7$ may be rewritten as $y = kx + 7$

PTS: 2 REF: 061015ia STA: A.A.38 TOP: Parallel and Perpendicular Lines

413 ANS: 1

Using $m = -\frac{A}{B}$, the slope of $2x - 3y = 9$ is $\frac{2}{3}$.

PTS: 2 REF: 011322ia STA: A.A.38 TOP: Parallel and Perpendicular Lines

414 ANS: 1

$m = -3$

PTS: 2 REF: 081307ia STA: A.A.38 TOP: Parallel and Perpendicular Lines

415 ANS: 3

$m = -3 \frac{-A}{B} = \frac{-6}{2} = -3$

PTS: 2 REF: 081427ia STA: A.A.38 TOP: Parallel and Perpendicular Lines

416 ANS: 1

$3(2m - 1) \leq 4m + 7$

$6m - 3 \leq 4m + 7$

$2m \leq 10$

$m \leq 5$

PTS: 2 REF: 081002ia STA: A.A.24 TOP: Solving Inequalities

417 ANS: 4

$-6x - 17 \geq 8x + 25$

$-42 \geq 14x$

$-3 \geq x$

PTS: 2 REF: 081121ia STA: A.A.24 TOP: Solving Inequalities

418 ANS:

$2(x - 4) \geq \frac{1}{2}(5 - 3x)$

$4(x - 4) \geq 5 - 3x$

$4x - 16 \geq 5 - 3x$

$7x \geq 21$

$x \geq 3$

PTS: 3 REF: 011234ia STA: A.A.24 TOP: Solving Inequalities

419 ANS:

$$-5(x - 7) < 15$$

$$x - 7 > -3$$

$$x > 4$$

PTS: 2

REF: 061331ia

STA: A.A.24

TOP: Solving Inequalities

420 ANS: 1

PTS: 2

REF: 011418ia

STA: A.A.24

TOP: Solving Inequalities

421 ANS: 1

$$4x - 30 \geq -3x + 12$$

$$7x \geq 42$$

$$x \geq 6$$

PTS: 2

REF: 061406ia

STA: A.A.24

TOP: Solving Inequalities

422 ANS: 1

$$-2x + 5 > 17$$

$$-2x > 12$$

$$x < -6$$

PTS: 2

REF: fall0724ia

STA: A.A.21

TOP: Interpreting Solutions

423 ANS: 4

$$-4x + 2 > 10$$

$$-4x > 8$$

$$x < -2$$

PTS: 2

REF: 080805ia

STA: A.A.21

TOP: Interpreting Solutions

424 ANS: 1

$$\frac{4}{3}x + 5 < 17$$

$$\frac{4}{3}x < 12$$

$$4x < 36$$

$$x < 9$$

PTS: 2

REF: 060914ia

STA: A.A.21

TOP: Interpreting Solutions

425 ANS: 4

$$-2(x - 5) < 4$$

$$-2x + 10 < 4$$

$$-2x < -6$$

$$x > 3$$

PTS: 2

REF: 080913ia

STA: A.A.21

TOP: Interpreting Solutions

426 ANS:

$$-12. 3\left(\frac{2}{3}x + 3 < -2x - 7\right)$$

$$x + 9 < -6x - 21$$

$$7x < -30$$

$$x < \frac{-30}{7}$$

PTS: 3

REF: 061034ia

STA: A.A.21

TOP: Interpreting Solutions

427 ANS: 1

$$-3x + 8 \geq 14$$

$$-3x \geq 6$$

$$x \leq -2$$

PTS: 2

REF: 081309ia

STA: A.A.21

TOP: Interpreting Solutions

428 ANS: 3

PTS: 2

REF: 081317ia

STA: A.A.21

TOP: Interpreting Solutions

429 ANS: 1

$$25x - 100 < 250$$

$$25x < 350$$

$$x < 14$$

PTS: 2

REF: 061517ia

STA: A.A.21

TOP: Interpreting Solutions

430 ANS: 1

PTS: 2

REF: 080803ia

STA: A.A.4

TOP: Modeling Inequalities

431 ANS: 4

PTS: 2

REF: 060906ia

STA: A.A.4

TOP: Modeling Inequalities

432 ANS: 3

PTS: 2

REF: 081410ia

STA: A.A.4

TOP: Modeling Inequalities

433 ANS: 4

PTS: 2

REF: fall0715ia

STA: A.A.5

TOP: Modeling Inequalities

434 ANS: 2

PTS: 2

REF: 060821ia

STA: A.A.5

TOP: Modeling Inequalities

435 ANS: 2

PTS: 2

REF: 011005ia

STA: A.A.5

TOP: Modeling Inequalities

436 ANS: 4

PTS: 2

REF: 081107ia

STA: A.A.5

TOP: Modeling Inequalities

437 ANS: 2

PTS: 2

REF: 081212ia

STA: A.A.5

TOP: Modeling Inequalities

438 ANS: 4

PTS: 2

REF: 061321ia

STA: A.A.5

TOP: Modeling Inequalities

439 ANS: 1

PTS: 2

REF: 011403ia

STA: A.A.5

TOP: Modeling Inequalities

440 ANS: 1

PTS: 2

REF: 011513ia

STA: A.A.5

TOP: Modeling Inequalities

- 441 ANS:
7. $15x + 22 \geq 120$
 $x \geq 6.5\bar{3}$
- PTS: 3 REF: fall0735ia STA: A.A.6 TOP: Modeling Inequalities
- 442 ANS:
 $10 + 2d \geq 75, 33. 10 + 2d \geq 75$
 $d \geq 32.5$
- PTS: 3 REF: 060834ia STA: A.A.6 TOP: Modeling Inequalities
- 443 ANS: 1
 $0.07m + 19 \leq 29.50$
 $0.07m \leq 10.50$
 $m \leq 150$
- PTS: 2 REF: 010904ia STA: A.A.6 TOP: Modeling Inequalities
- 444 ANS: 1
 $13.95 + 0.49s \leq 50.00$
 $0.49s \leq 36.05$
 $s \leq 73.57$
- PTS: 2 REF: 080904ia STA: A.A.6 TOP: Modeling Inequalities
- 445 ANS:
 $0.65x + 35 \leq 45$
 $0.65x \leq 10$
 $x \leq 15$
- PTS: 3 REF: 061135ia STA: A.A.6 TOP: Modeling Inequalities
- 446 ANS: 3
 $5x < 55$
 $x < 11$
- PTS: 2 REF: 061211ia STA: A.A.6 TOP: Modeling Inequalities
- 447 ANS: 4
 $375 + 155w \geq 900$
 $155w \geq 525$
 $w \geq 3.4$
- PTS: 2 REF: 081206ia STA: A.A.6 TOP: Modeling Inequalities

448 ANS:

$$0.25 + 0.10(m - 4) \leq 2.10 \quad 22 \text{ minutes}$$

$$0.10(m - 4) \leq 1.85$$

$$m - 4 \leq 18.5$$

$$m \leq 22.5$$

PTS: 4 REF: 061539ia STA: A.A.6 TOP: Modeling Inequalities

449 ANS: 2

The slope of the inequality is $-\frac{1}{2}$.

PTS: 2 REF: fall0720ia STA: A.G.6 TOP: Linear Inequalities

450 ANS: 1 PTS: 2 REF: 060920ia STA: A.G.6

TOP: Linear Inequalities

451 ANS:

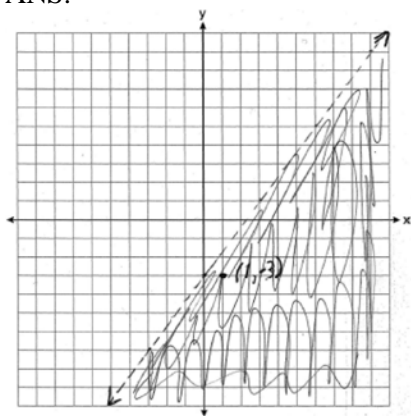
(1, -3) is in the solution set. $4(1) - 3(-3) > 9$

$$4 + 9 > 9$$

PTS: 4 REF: 011038ia STA: A.G.6 TOP: Linear Inequalities

452 ANS: 4 PTS: 2 REF: 061028ia STA: A.G.6

TOP: Linear Inequalities

453 ANS: 1 PTS: 2 REF: 011210ia STA: A.G.6

TOP: Linear Inequalities

454 ANS: 4 PTS: 2 REF: 061320ia STA: A.G.6

TOP: Linear Inequalities

455 ANS: 2 PTS: 2 REF: 081314ia STA: A.G.6

TOP: Linear Inequalities

456 ANS: 3

$$y > 2x - 3$$

PTS: 2 REF: 011422ia STA: A.G.6 TOP: Linear Inequalities

457 ANS: 3 PTS: 2 REF: 061505ia STA: A.G.6

TOP: Linear Inequalities

458 ANS: 3 PTS: 2 REF: 011117ia STA: A.G.4

TOP: Graphing Absolute Value Functions

459 ANS:

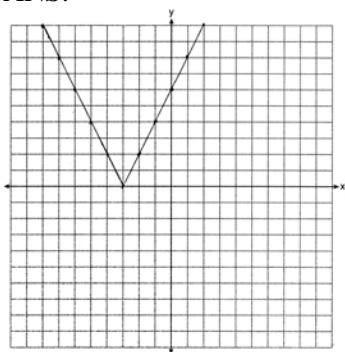

PTS: 2 REF: 011333ia STA: A.G.4 TOP: Graphing Absolute Value Functions

460 ANS: 4 PTS: 2 REF: 081425ia STA: A.G.4

TOP: Graphing Absolute Value Functions

461 ANS: 4

The transformation is a reflection in the x -axis.

PTS: 2 REF: fall0722ia STA: A.G.5 TOP: Graphing Absolute Value Functions

462 ANS: 3 PTS: 2 REF: 011017ia STA: A.G.5

TOP: Graphing Absolute Value Functions

463 ANS:

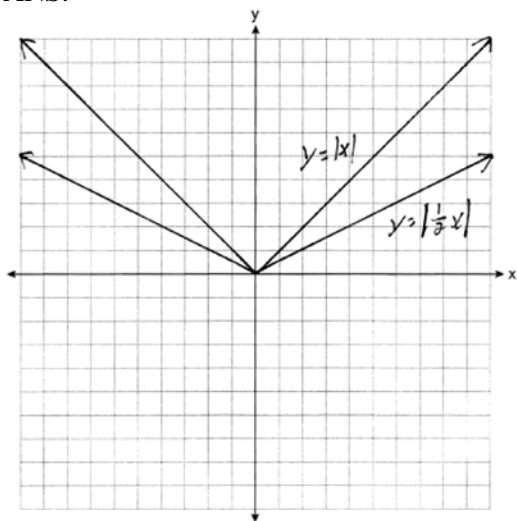

. Graph becomes wider as the coefficient approaches 0.

PTS: 3 REF: 061035ia STA: A.G.5 TOP: Graphing Absolute Value Functions

464 ANS:

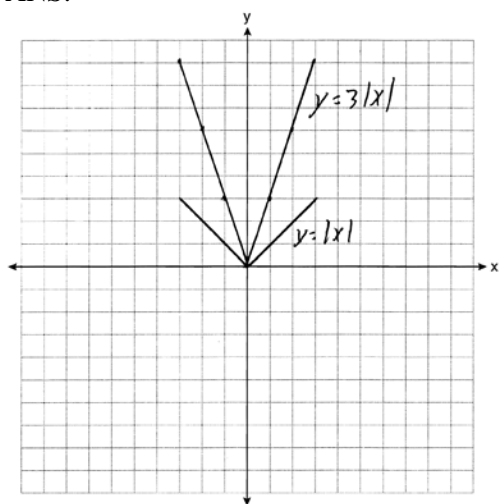

The graph becomes steeper.

PTS: 3 REF: 081134ia STA: A.G.5 TOP: Graphing Absolute Value Functions

465 ANS: 4

The transformation is a reflection in the x -axis.

PTS: 2 REF: 011206ia STA: A.G.5 TOP: Graphing Absolute Value Functions

466 ANS:

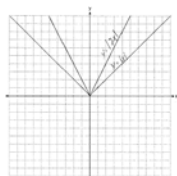

. Graph becomes narrower as the coefficient increases.

PTS: 3 REF: 011434ia STA: A.G.5 TOP: Graphing Absolute Value Functions

467 ANS: 1 PTS: 2 REF: 011529ia STA: A.G.5

TOP: Graphing Absolute Value Functions

468 ANS: 2

$$2x^2 + 10x - 12 = 2(x^2 + 5x - 6) = 2(x + 6)(x - 1)$$

PTS: 2 REF: 080806ia STA: A.A.20 TOP: Factoring Polynomials

469 ANS: 2 PTS: 2 REF: 061027ia STA: A.A.20

TOP: Factoring Polynomials

470 ANS: 2 PTS: 2 REF: 061105ia STA: A.A.20

TOP: Factoring Polynomials

471 ANS: 4

$$3x^3 - 33x^2 + 90x = 3x(x^2 - 11x + 30) = 3x(x - 5)(x - 6)$$

PTS: 2 REF: 061227ia STA: A.A.20 TOP: Factoring Polynomials

472 ANS:

$$5x^3 - 20x^2 - 60x$$

$$5x(x^2 - 4x - 12)$$

$$5x(x+2)(x-6)$$

PTS: 2 REF: 011332ia STA: A.A.20 TOP: Factoring Polynomials

473 ANS: 3

$$3mn(m+4n)$$

PTS: 2 REF: 011402ia STA: A.A.20 TOP: Factoring Polynomials

474 ANS: 4

$$3x^2 - 9x + 6 = 3(x^2 - 3x + 2) = 3(x-1)(x-2)$$

PTS: 2 REF: 061421ia STA: A.A.20 TOP: Factoring Polynomials

475 ANS: 3

TOP: Factoring the Difference of Perfect Squares

PTS: 2 REF: fall0706ia

STA: A.A.19

476 ANS: 1

TOP: Factoring the Difference of Perfect Squares

PTS: 2 REF: 060804ia

STA: A.A.19

477 ANS: 2

TOP: Factoring the Difference of Perfect Squares

PTS: 2 REF: 010909ia

STA: A.A.19

478 ANS:

$$4x(x+3)(x-3). \quad 4x^3 - 36x = 4x(x^2 - 9) = 4x(x+3)(x-3)$$

PTS: 2 REF: 060932ia STA: A.A.19

TOP: Factoring the Difference of Perfect Squares

479 ANS: 1

TOP: Factoring the Difference of Perfect Squares

PTS: 2 REF: 080902ia

STA: A.A.19

480 ANS: 2

TOP: Factoring the Difference of Perfect Squares

PTS: 2 REF: 011022ia

STA: A.A.19

481 ANS: 3

TOP: Factoring the Difference of Perfect Squares

PTS: 2 REF: 081008ia

STA: A.A.19

482 ANS: 2

$$a^3 - 4a = a(a^2 - 4) = a(a-2)(a+2)$$

PTS: 2 REF: 011108ia STA: A.A.19

TOP: Factoring the Difference of Perfect Squares

483 ANS: 3

TOP: Factoring the Difference of Perfect Squares

PTS: 2 REF: 061101ia

STA: A.A.19

484 ANS: 2

$$36x^2 - 100y^6 = 4(9x^2 - 25y^6) = 4(3x + 5y^3)(3x - 5y^3)$$

PTS: 2 REF: 081129ia STA: A.A.19

TOP: Factoring the Difference of Perfect Squares

485 ANS: 2

TOP: Factoring the Difference of Perfect Squares

PTS: 2 REF: 011201ia

STA: A.A.19

- 486 ANS: 3 PTS: 2 REF: 081207ia STA: A.A.19
TOP: Factoring the Difference of Perfect Squares
- 487 ANS: 1 PTS: 2 REF: 011306ia STA: A.A.19
TOP: Factoring the Difference of Perfect Squares
- 488 ANS: 2 PTS: 2 REF: 081403ia STA: A.A.19
TOP: Factoring the Difference of Perfect Squares
- 489 ANS: 3 PTS: 2 REF: 061506ia STA: A.A.19
TOP: Factoring the Difference of Perfect Squares
- 490 ANS: 3
 $x^2 - 6x = 0$
 $x(x - 6) = 0$
 $x = 0 \quad x = 6$
- PTS: 2 REF: 080921ia STA: A.A.27 TOP: Solving Quadratics by Factoring
- 491 ANS: 2
 $x^2 - 16x + 28 = 0$
 $(x - 14)(x - 2) = 0$
 $x = 14, 2$
- PTS: 2 REF: 061311ia STA: A.A.27 TOP: Solving Quadratics by Factoring
- 492 ANS: 3
 $x^2 - 10x + 21 = 0$
 $(x - 7)(x - 3) = 0$
 $x = 7 \quad x = 3$
- PTS: 2 REF: 010914ia STA: A.A.28 TOP: Roots of Quadratics

Integrated Algebra Regents Exam Questions by Performance Indicator: Topic Answer Section

493 ANS: 4

$$x^2 - 7x + 6 = 0$$

$$(x - 6)(x - 1) = 0$$

$$x = 6 \quad x = 1$$

PTS: 2

REF: 060902ia

STA: A.A.28

TOP: Roots of Quadratics

494 ANS:

$$-2, 3. \quad x^2 - x = 6$$

$$x^2 - x - 6 = 0$$

$$(x - 3)(x + 2) = 0$$

$$x = 3 \text{ or } -2$$

PTS: 3

REF: 011034ia

STA: A.A.28

TOP: Roots of Quadratics

495 ANS:

$$-15, 2 \quad x^2 + 13x - 30 = 0$$

$$(x + 15)(x - 2) = 0$$

$$x = -15, 2$$

PTS: 3

REF: 081036ia

STA: A.A.28

TOP: Roots of Quadratics

496 ANS: 2

$$x^2 - 2x - 15 = 0$$

$$(x - 5)(x + 3) = 0$$

$$x = 5 \quad x = -3$$

PTS: 2

REF: 011128ia

STA: A.A.28

TOP: Roots of Quadratics

497 ANS: 2

$$x^2 - 5x + 6 = 0$$

$$(x - 3)(x - 2) = 0$$

$$x = 3 \quad x = 2$$

PTS: 2

REF: 081120ia

STA: A.A.28

TOP: Roots of Quadratics

498 ANS: 1

$$3x^2 - 27x = 0$$

$$3x(x - 9) = 0$$

$$x = 0, 9$$

PTS: 2

REF: 011223ia

STA: A.A.28

TOP: Roots of Quadratics

499 ANS: 4

$$x^2 - 14x + 48 = 0$$

$$(x - 6)(x - 8) = 0$$

$$x = 6, 8$$

PTS: 2

REF: 011320ia

STA: A.A.28

TOP: Roots of Quadratics

500 ANS: 2

PTS: 2

REF: 061326ia

STA: A.A.28

TOP: Roots of Quadratics

501 ANS: 4

$$2x^2 - 8x = 0$$

$$2x(x - 4) = 0$$

$$x = 0, 4$$

PTS: 2

REF: 011427ia

STA: A.A.28

TOP: Roots of Quadratics

502 ANS: 1

PTS: 2

REF: 081420ia

STA: A.A.28

TOP: Roots of Quadratics

503 ANS:

$$(x + 12)(x - 2) = 0$$

$$x^2 + 10x - 24 = 0$$

PTS: 2

REF: 061533ia

STA: A.A.28

TOP: Roots of Quadratics

504 ANS: 4

PTS: 2

REF: 060829ia

STA: A.G.5

TOP: Graphing Quadratic Functions

505 ANS: 1

PTS: 2

REF: 081015ia

STA: A.G.5

TOP: Graphing Quadratic Functions

506 ANS: 2

PTS: 2

REF: 061113ia

STA: A.G.5

TOP: Graphing Quadratic Functions

507 ANS: 2

PTS: 2

REF: 081218ia

STA: A.G.5

TOP: Graphing Quadratic Functions

508 ANS: 2

PTS: 2

REF: 011330ia

STA: A.G.5

TOP: Graphing Quadratic Functions

509 ANS: 4

PTS: 2

REF: 081322ia

STA: A.G.5

TOP: Graphing Quadratic Functions

510 ANS: 2

PTS: 2

REF: 081414ia

STA: A.G.5

TOP: Graphing Quadratic Functions

511 ANS: 4

PTS: 2

REF: 061503ia

STA: A.G.5

TOP: Graphing Quadratic Functions

512 ANS:

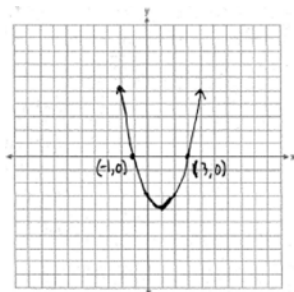

PTS: 3 REF: 060836ia

STA: A.G.8

TOP: Solving Quadratics by Graphing

513 ANS: 3 PTS: 2

REF: 060924ia

STA: A.G.8

TOP: Solving Quadratics by Graphing

514 ANS: 2 PTS: 2

REF: 080916ia

STA: A.G.8

TOP: Solving Quadratics by Graphing

515 ANS: 4 PTS: 2

REF: 011111ia

STA: A.G.8

TOP: Solving Quadratics by Graphing

516 ANS:

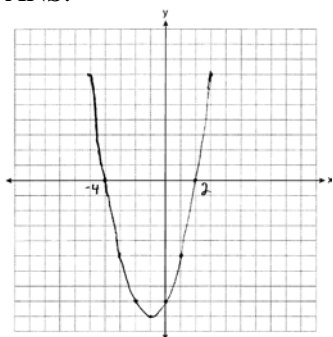

PTS: 3 REF: 061234ia

STA: A.G.8

TOP: Solving Quadratics by Graphing

517 ANS: 3 PTS: 2

REF: 061306ia

STA: A.G.8

TOP: Solving Quadratics by Graphing

518 ANS: 3 PTS: 2

REF: 061404ia

STA: A.G.8

TOP: Solving Quadratics by Graphing

519 ANS: 2 PTS: 2

REF: 011506ia

STA: A.G.8

TOP: Solving Quadratics by Graphing

520 ANS:

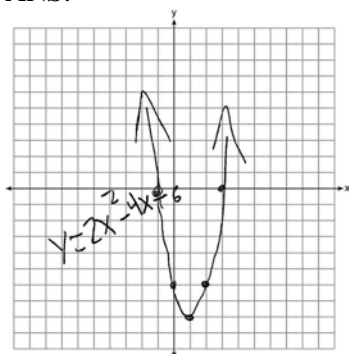

3 and -1.

PTS: 4

REF: 061537ia

STA: A.G.8

TOP: Solving Quadratics by Graphing

521 ANS: 4

$$P = 0.0089(125)^2 + 1.1149(125) + 78.4491 \approx 356.9$$

PTS: 2

REF: 061422ia

STA: A.A.8

TOP: Quadratic Functions

522 ANS: 2

$$-16x^2 + 32x = 0$$

$$-16x(x - 2) = 0$$

$$x = 0, 2$$

PTS: 2

REF: 011524ia

STA: A.A.8

TOP: Quadratic Functions

523 ANS:

6, 8, 10. Three consecutive even integers are x , $x + 2$ and $x + 4$. $(x + 2)(x + 4) = 10x + 20$

$$x^2 + 6x + 8 = 10x + 20$$

$$x^2 - 4x - 12 = 0$$

$$(x - 6)(x + 2) = 0$$

$$x = 6$$

PTS: 4

REF: 011039ia

STA: A.A.8

TOP: Writing Quadratics

524 ANS: 1

$$x^2 - 36 = 5x$$

$$x^2 - 5x - 36 = 0$$

$$(x - 9)(x + 4) = 0$$

$$x = 9$$

PTS: 2

REF: 061020ia

STA: A.A.8

TOP: Writing Quadratics

525 ANS: 3

$$b = 3 + d \quad (3 + d)d = 40$$

$$bd = 40 \quad d^2 + 3d - 40 = 0$$

$$(d + 8)(d - 5) = 0$$

$$d = 5$$

PTS: 2

REF: 011208ia

STA: A.A.8

TOP: Writing Quadratics

526 ANS: 3

$$N = 5 + J \quad N(N - 5) = 84$$

$$J = N - 5 \quad N^2 - 5N - 84 = 0$$

$$NJ = 84 \quad (N - 12)(N + 7) = 0$$

$$N = 12$$

PTS: 2

REF: 081304ia

STA: A.A.8

TOP: Writing Quadratics

527 ANS: 2

$$x^2 = 5x + 24$$

$$x^2 - 5x - 24 = 0$$

$$(x - 8)(x + 3) = 0$$

$$x = 8$$

PTS: 2

REF: 061518ia

STA: A.A.8

TOP: Writing Quadratics

528 ANS:

$$w(w + 15) = 54, 3, 18. \quad w(w + 15) = 54$$

$$w^2 + 15w - 54 = 0$$

$$(w + 18)(w - 3) = 0$$

$$w = 3$$

PTS: 4

REF: 060837ia

STA: A.A.8

TOP: Geometric Applications of Quadratics

529 ANS: 2

$$l(l - 5) = 24$$

$$l^2 - 5l - 24 = 0$$

$$(l - 8)(l + 3) = 0$$

$$l = 8$$

PTS: 2

REF: 080817ia

STA: A.A.8

TOP: Geometric Applications of Quadratics

530 ANS: 2

$$l(l-3) = 40$$

$$l^2 - 3l - 40 = 0$$

$$(l-8)(l+5) = 0$$

$$l = 8$$

PTS: 2 REF: 081116ia STA: A.A.8 TOP: Geometric Applications of Quadratics

531 ANS: 1 PTS: 2 REF: 060811ia STA: A.G.10

TOP: Identifying the Vertex of a Quadratic Given Graph

532 ANS: 1 PTS: 2 REF: 080813ia STA: A.G.10

TOP: Identifying the Vertex of a Quadratic Given Graph

533 ANS: 2 PTS: 2 REF: 010916ia STA: A.G.10

TOP: Identifying the Vertex of a Quadratic Given Graph

534 ANS: 2 PTS: 2 REF: 011015ia STA: A.G.10

TOP: Identifying the Vertex of a Quadratic Given Graph

535 ANS: 1 PTS: 2 REF: 061005ia STA: A.G.10

TOP: Identifying the Vertex of a Quadratic Given Graph

536 ANS:

$$x = 1; (1, -5)$$

PTS: 2 REF: 061133ia STA: A.G.10

TOP: Identifying the Vertex of a Quadratic Given Graph

537 ANS: 2 PTS: 2 REF: 081111ia STA: A.G.10

TOP: Identifying the Vertex of a Quadratic Given Graph

538 ANS: 4 PTS: 2 REF: 081214ia STA: A.G.10

TOP: Identifying the Vertex of a Quadratic Given Graph

539 ANS: 1 PTS: 2 REF: 061420ia STA: A.G.10

TOP: Identifying the Vertex of a Quadratic Given Graph

540 ANS: 1 PTS: 2 REF: 081405ia STA: A.G.10

TOP: Identifying the Vertex of a Quadratic Given Graph

541 ANS: 1

$$x = \frac{-b}{2a} = \frac{-(-16)}{2(1)} = 8. \quad y = (8)^2 - 16(8) + 63 = -1$$

PTS: 2 REF: 060918ia STA: A.A.41

TOP: Identifying the Vertex of a Quadratic Given Equation

542 ANS:

$$(-2, 11). \quad x = \frac{-b}{2a} = \frac{-(-8)}{2(-2)} = -2$$

$$y = -2(-2)^2 - 8(-2) + 3 = 11$$

PTS: 3 REF: 080934ia STA: A.A.41

TOP: Identifying the Vertex of a Quadratic Given Equation

543 ANS: 3

$$x = \frac{-b}{2a} = \frac{-10}{2(-1)} = 5.$$

PTS: 2 REF: 081018ia STA: A.A.41
TOP: Identifying the Vertex of a Quadratic Given Equation

544 ANS: 1

$$x = \frac{-b}{2a} = \frac{-6}{2(-1)} = 3.$$

PTS: 2 REF: 011127ia STA: A.A.41
TOP: Identifying the Vertex of a Quadratic Given Equation

545 ANS: 1

$$x = \frac{-b}{2a} = \frac{-(-3)}{2(2)} = \frac{3}{4}.$$

PTS: 2 REF: 011219ia STA: A.A.41
TOP: Identifying the Vertex of a Quadratic Given Equation

546 ANS: 3

$$x = \frac{-b}{2a} = \frac{-24}{2(-2)} = 6. \quad y = -2(6)^2 + 24(6) - 100 = -28$$

PTS: 2 REF: 061214ia STA: A.A.41
TOP: Identifying the Vertex of a Quadratic Given Equation

547 ANS: 3

$$x = \frac{-b}{2a} = \frac{-8}{2(1)} = -4. \quad y = (-4)^2 + 8(-4) + 10 = -6. \quad (-4, -6)$$

PTS: 2 REF: 011314ia STA: A.A.41
TOP: Identifying the Vertex of a Quadratic Given Equation

548 ANS: 1

$$x = \frac{-b}{2a} = \frac{-6}{2(3)} = -1. \quad y = 3(-1)^2 + 6(-1) + 1 = -2$$

PTS: 2 REF: 011416ia STA: A.A.41
TOP: Identifying the Vertex of a Quadratic Given Equation

549 ANS: 1

$$x = \frac{-b}{2a} = \frac{-4}{2(1)} = -2$$

PTS: 2 REF: 011520ia STA: A.A.41
TOP: Identifying the Vertex of a Quadratic Given Equation

550 ANS:

$$x = \frac{-(-2)}{2(-1)} = \frac{2}{-2} = -1 \quad y = -(-1)^2 - 2(-1) + 1 = -1 + 2 + 1 = 2 \quad x = -1 \quad (-1, 2)$$

PTS: 3 REF: 061534ia STA: A.A.41
TOP: Identifying the Vertex of a Quadratic Given Equation

551 ANS: 3

$$5x + 2y = 48$$

$$3x + 2y = 32$$

$$2x = 16$$

$$x = 8$$

PTS: 2 REF: fall0708ia STA: A.A.10 TOP: Solving Linear Systems

552 ANS:

$$(-2, 5). \quad 3x + 2y = 4 \quad 12x + 8y = 16. \quad 3x + 2y = 4$$

$$4x + 3y = 7 \quad 12x + 9y = 21 \quad 3x + 2(5) = 4$$

$$y = 5 \quad 3x = -6$$

$$x = -2$$

PTS: 4 REF: 010937ia STA: A.A.10 TOP: Solving Linear Systems

553 ANS: 2

$$x + 2y = 9$$

$$x - y = 3$$

$$3y = 6$$

$$y = 2$$

PTS: 2 REF: 060925ia STA: A.A.10 TOP: Solving Linear Systems

554 ANS: 1

$$x - 2y = 1$$

$$x + 4y = 7$$

$$-6y = -6$$

$$y = 1$$

PTS: 2 REF: 080920ia STA: A.A.10 TOP: Solving Linear Systems

555 ANS: 3

$$c + 3d = 8 \quad c = 4d - 6$$

$$4d - 6 + 3d = 8 \quad c = 4(2) - 6$$

$$7d = 14 \quad c = 2$$

$$d = 2$$

PTS: 2 REF: 061012ia STA: A.A.10 TOP: Solving Linear Systems

556 ANS: 2

$$2(x - 3y = -3)$$

$$2x + y = 8$$

$$2x - 6y = -6$$

$$7y = 14$$

$$y = 2$$

PTS: 2

REF: 081021ia

STA: A.A.10

TOP: Solving Linear Systems

557 ANS: 3

$$2x - 5y = 11 \quad 2x - 5(-1) = 11$$

$$-2x + 3y = -9$$

$$2x = 6$$

$$-2y = 2$$

$$x = 3$$

$$y = -1$$

PTS: 2

REF: 081109ia

STA: A.A.10

TOP: Solving Linear Systems

558 ANS:

2. Subtracting the equations: $3y = 6$

$$y = 2$$

PTS: 2

REF: 061231ia

STA: A.A.10

TOP: Solving Linear Systems

559 ANS: 1

PTS: 2

REF: 081315ia

STA: A.A.10

TOP: Solving Linear Systems

560 ANS: 2

$$2x + 3y = 7$$

$$3x + 3y = 9$$

$$x = 2$$

PTS: 2

REF: 011410ia

STA: A.A.10

TOP: Solving Linear Systems

561 ANS: 2

$$3x + 2y = 12$$

$$5x - 2y = 4$$

$$8x = 16$$

$$x = 2$$

PTS: 2

REF: 061409ia

STA: A.A.10

TOP: Solving Linear Systems

562 ANS: 3
 $6x + 5y = 300$
 $6x + 14y = 570$
 $9y = 270$
 $y = 30$

PTS: 2 REF: 011519ia STA: A.A.10 TOP: Solving Linear Systems

563 ANS: 3
 $2\left(\frac{1}{2}b - 6\right) + 3b = 12$ $2a + 3(6) = 12$
 $b - 12 + 3b = 12$ $2a = -6$
 $4b = 24$ $a = -3$
 $b = 6$

PTS: 2 REF: 061511ia STA: A.A.10 TOP: Solving Linear Systems

564 ANS:

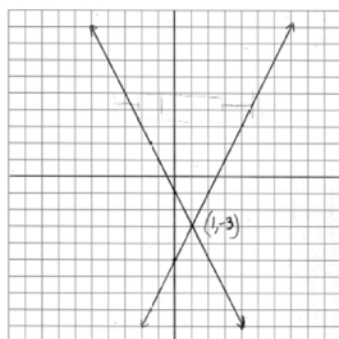

PTS: 4 REF: 080938ia STA: A.G.7 TOP: Solving Linear Systems

565 ANS:

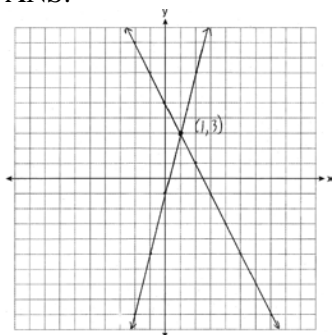

PTS: 3 REF: 011235ia STA: A.G.7 TOP: Solving Linear Systems

566 ANS: 3 PTS: 2 REF: 081201ia STA: A.G.7
 TOP: Solving Linear Systems

567 ANS: 3 PTS: 2 REF: 011304ia STA: A.G.7
 TOP: Solving Linear Systems

568 ANS: 2

$$3c + 4m = 12.50$$

$$3c + 2m = 8.50$$

$$2m = 4.00$$

$$m = 2.00$$

PTS: 2

REF: 060806ia

STA: A.A.7

TOP: Writing Linear Systems

569 ANS: 3

$$b = 42 - r \quad r = 2b + 3$$

$$r = 2b + 3 \quad r = 2(42 - r) + 3$$

$$r = 84 - 2r + 3$$

$$3r = 87$$

$$r = 29$$

PTS: 2

REF: 060812ia

STA: A.A.7

TOP: Writing Linear Systems

570 ANS: 2

$$s + o = 126. \quad s + 2s = 126$$

$$o = 2s \quad s = 42$$

PTS: 2

REF: 080811ia

STA: A.A.7

TOP: Writing Linear Systems

571 ANS:

$$m = 50¢, p = 15¢. \quad 3m + 2p = 1.80. \quad 9m + 6p = 5.40 \quad . \quad 4(.50) + 6p = 2.90$$

$$4m + 6p = 2.90 \quad 4m + 6p = 2.90 \quad 6p = .90$$

$$5m = 2.50 \quad p = \$0.15$$

$$m = \$0.50$$

PTS: 4

REF: 080837ia

STA: A.A.7

TOP: Writing Linear Systems

572 ANS: 2

$$L + S = 47$$

$$L - S = 15$$

$$2L = 62$$

$$L = 31$$

PTS: 2

REF: 060912ia

STA: A.A.7

TOP: Writing Linear Systems

573 ANS: 1

$$so = f + 60 \quad j = 2f - 50 \quad se = 3f. \quad f + (f + 60) + (2f - 50) + 3f = 1424$$

$$7f + 10 = 1424$$

$$f = 202$$

PTS: 2

REF: 060917ia

STA: A.A.7

TOP: Writing Linear Systems

- 574 ANS: 1
 $1P + 2C = 5$
 $1P + 4C = 6$
 $2C = 1$
 $C = 0.5$
- PTS: 2 REF: 011003ia STA: A.A.7 TOP: Writing Linear Systems
- 575 ANS: 2
 $J - M = 3$
 $8J + 8M = 120$
 $8J - 8M = 24$
 $16J = 144$
 $J = 9$
- PTS: 2 REF: 011115ia STA: A.A.7 TOP: Writing Linear Systems
- 576 ANS: 1
 $f + m = 53$
 $f - m = 25$
 $2m = 28$
 $m = 14$
- PTS: 2 REF: 061126ia STA: A.A.7 TOP: Writing Linear Systems
- 577 ANS: 1
 $b = 2j + 4$ $2j + 4 = 31 - j$
 $b + j = 31$ $3j = 27$
 $b = 31 - j$ $j = 9$
- PTS: 2 REF: 081119ia STA: A.A.7 TOP: Writing Linear Systems
- 578 ANS: 2
 $W + L = 72$
 $W - L = 12$
 $2W = 84$
 $W = 42$
- PTS: 2 REF: 081227ia STA: A.A.7 TOP: Writing Linear Systems

579 ANS:

$$3n + 4p = 8.50 \quad . \quad 3(2.50) + 4p = 8.50$$

$$5n + 8p = 14.50 \quad 4p = 1$$

$$6n + 8p = 17 \quad p = 0.25$$

$$n = 2.50$$

PTS: 3 REF: 011335ia STA: A.A.7 TOP: Writing Linear Systems

580 ANS:

$$L - S = 28 \quad . \quad 2S - 8 = S + 28$$

$$L = 2S - 8 \quad S = 36$$

$$L = S + 28 \quad L = 36 + 28 = 64$$

PTS: 3 REF: 081335ia STA: A.A.7 TOP: Writing Linear Systems

581 ANS:

$$a + o = 108 \quad 64 + o = 108$$

$$5a + 3o = 452 \quad o = 44$$

$$3a + 3o = 324$$

$$2a = 128$$

$$a = 64$$

PTS: 4 REF: 061437ia STA: A.A.7 TOP: Writing Linear Systems

582 ANS:

$$d = 2c \quad 2(2c) + 2c = 45$$

$$2d + 2c = 45 \quad 6c = 45$$

$$c = 7.50$$

PTS: 3 REF: 011534ia STA: A.A.7 TOP: Writing Linear Systems

583 ANS: 4

PTS: 2

REF: 061504ia

STA: A.A.7

TOP: Writing Linear Systems

584 ANS: 4

PTS: 2

REF: 080825ia

STA: A.A.40

TOP: Systems of Linear Inequalities

585 ANS: 2

PTS: 2

REF: 011023ia

STA: A.A.40

TOP: Systems of Linear Inequalities

586 ANS: 1

PTS: 2

REF: 061010ia

STA: A.A.40

TOP: Systems of Linear Inequalities

587 ANS: 2

PTS: 2

REF: 081127ia

STA: A.A.40

TOP: Systems of Linear Inequalities

588 ANS: 4

PTS: 2

REF: 061222ia

STA: A.A.40

TOP: Systems of Linear Inequalities

589 ANS: 2

$$-1 \leq 3(2) + 1. \quad 2 - (-1) > 1$$

$$-1 \leq 7 \qquad 3 > 1$$

PTS: 2

REF: 011323ia

STA: A.A.40

TOP: Systems of Linear Inequalities

590 ANS:

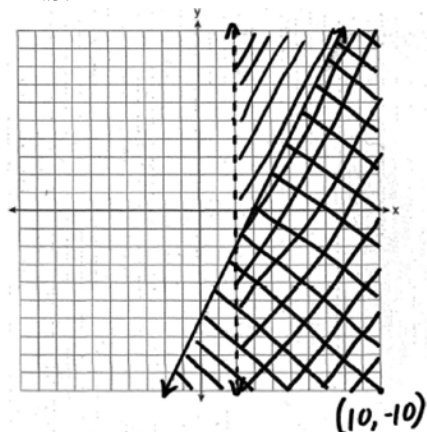

PTS: 4

REF: 010938ia

STA: A.G.7

TOP: Systems of Linear Inequalities

591 ANS:

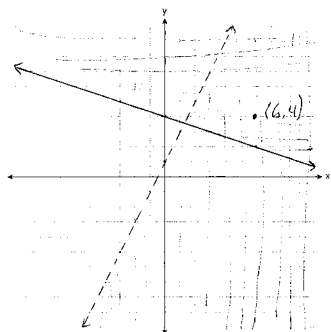

PTS: 4

REF: 081037ia

STA: A.G.7

TOP: Systems of Linear Inequalities

592 ANS:

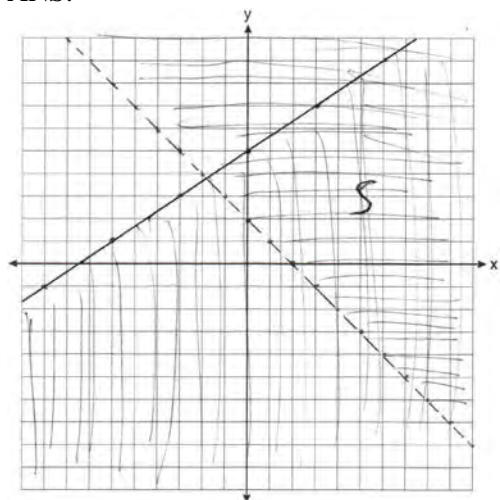

PTS: 4

REF: 011139ia

STA: A.G.7

TOP: Systems of Linear Inequalities

593 ANS:

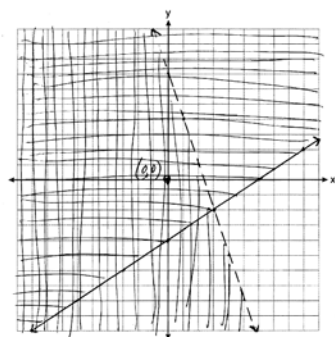

PTS: 4

REF: 061139ia

STA: A.G.7

TOP: Systems of Linear Inequalities

594 ANS:

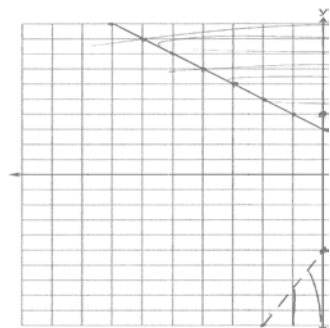

PTS: 4

REF: 081239ia

STA: A.G.7

TOP: Systems of Linear Inequalities

595 ANS:

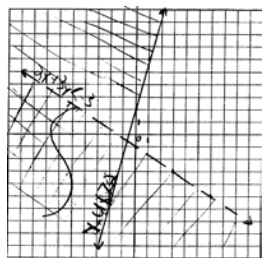

PTS: 4

REF: 061438ia

STA: A.G.7

TOP: Systems of Linear Inequalities

596 ANS:

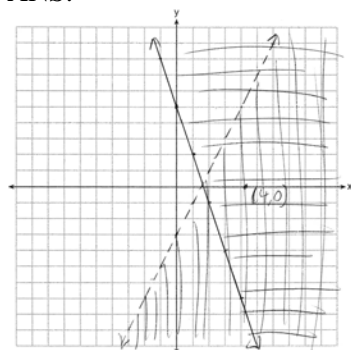

PTS: 4

REF: 081437ia

STA: A.G.7

TOP: Systems of Linear Inequalities

597 ANS:

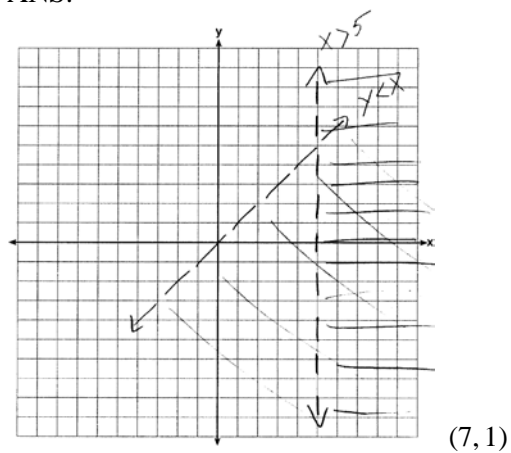

PTS: 3

REF: 011536ia

STA: A.G.7

TOP: Systems of Linear Inequalities

598 ANS: 4

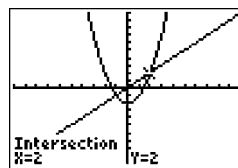

$$x^2 - 2 = x \quad \text{Since } y = x, \text{ the solutions are } (2, 2) \text{ and } (-1, -1).$$

$$x^2 - x - 2 = 0$$

$$(x - 2)(x + 1) = 0$$

$$x = 2 \text{ or } -1$$

PTS: 2

REF: 060810ia

STA: A.A.11

TOP: Quadratic-Linear Systems

599 ANS: 2

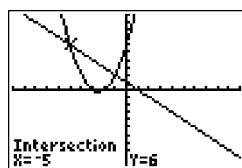

$$x^2 + 5x + 6 = -x + 1. \quad y = -x + 1$$

$$x^2 + 6x + 5 = 0 \quad = -(-5) + 1$$

$$(x + 5)(x + 1) = 0 \quad = 6$$

$$x = -5 \text{ or } -1$$

PTS: 2

REF: 080812ia

STA: A.A.11

TOP: Quadratic-Linear Systems

600 ANS: 2

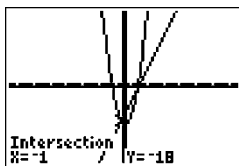

$$x^2 - x - 20 = 3x - 15. \quad y = 3x - 15$$

$$x^2 - 4x - 6 = 0 \quad = 3(-1) - 15$$

$$(x - 5)(x + 1) = 0 \quad = -18$$

$$x = 5 \text{ or } -1$$

PTS: 2

REF: 010922ia

STA: A.A.11

TOP: Quadratic-Linear Systems

601 ANS: 2

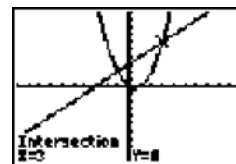

$$x^2 - x = x + 3. \quad \text{Since } y = x + 3, \text{ the solutions are } (3, 6) \text{ and } (-1, 2).$$

$$x^2 - 2x - 3 = 0$$

$$(x - 3)(x + 1) = 0$$

$$x = 3 \text{ or } -1$$

PTS: 2

REF: 061118ia

STA: A.A.11

TOP: Quadratic-Linear Systems

602 ANS: 2

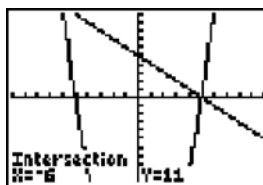

$$y = -x + 5. \quad -x + 5 = x^2 - 25 \quad . \quad y = -(-6) + 5 = 11.$$

$$0 = x^2 + x - 30 \quad y = -5 + 5 = 0$$

$$0 = (x + 6)(x - 5)$$

$$x = -6, 5$$

PTS: 2 REF: 061213ia STA: A.A.11 TOP: Quadratic-Linear Systems

603 ANS:

$$(-3, -5), (3, 7). \quad x^2 + 2x - 8 = 2x + 1. \quad y = 2(3) + 1 = 7$$

$$x^2 - 9 = 0 \quad y = 2(-3) + 1 = -5$$

$$x = \pm 3$$

PTS: 3 REF: 081236ia STA: A.A.11 TOP: Quadratic-Linear Systems

604 ANS:

$$(-3, -5), (3, 7). \quad x^2 + 2x - 8 = 2x + 1. \quad y = 2(3) + 1 = 7$$

$$x^2 - 9 = 0 \quad y = 2(-3) + 1 = -5$$

$$x = \pm 3$$

PTS: 3 REF: 061434ia STA: A.A.11 TOP: Quadratic-Linear Systems

605 ANS:

$$x^2 - 6x + 9 = -9x + 19 \quad y = -9(-5) + 19 = 64 \quad (-5, 64) \text{ and } (2, 1)$$

$$x^2 + 3x - 10 = 0 \quad y = -9(2) + 19 = 1$$

$$(x + 5)(x - 2) = 0$$

$$x = -5, 2$$

PTS: 4 REF: 081439ia STA: A.A.11 TOP: Quadratic-Linear Systems

606 ANS:

$$x^2 + 5x - 17 = x - 5 \quad y = -6 - 5 = -11 \quad (-6, -11), (2, -3)$$

$$x^2 + 4x - 12 = 0 \quad y = 2 - 5 = -3$$

$$(x + 6)(x - 2) = 0$$

$$x = -6, 2$$

PTS: 4 REF: 011538ia STA: A.A.11 TOP: Quadratic-Linear Systems

607 ANS:

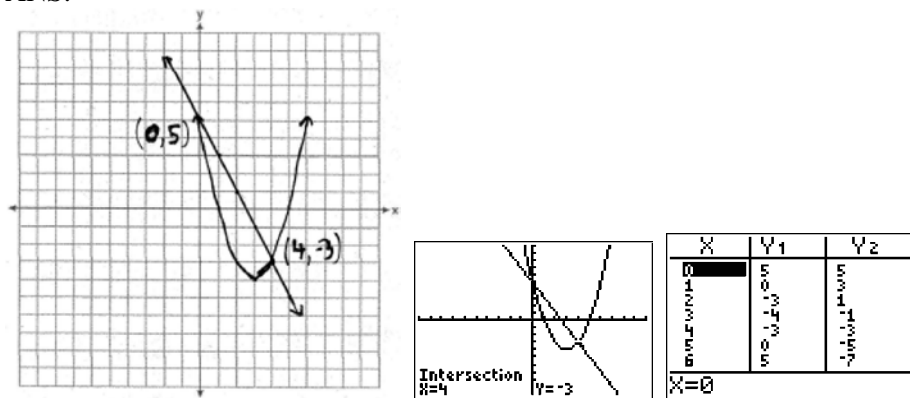

PTS: 4

REF: fall0738ia

STA: A.G.9

TOP: Quadratic-Linear Systems

608 ANS:

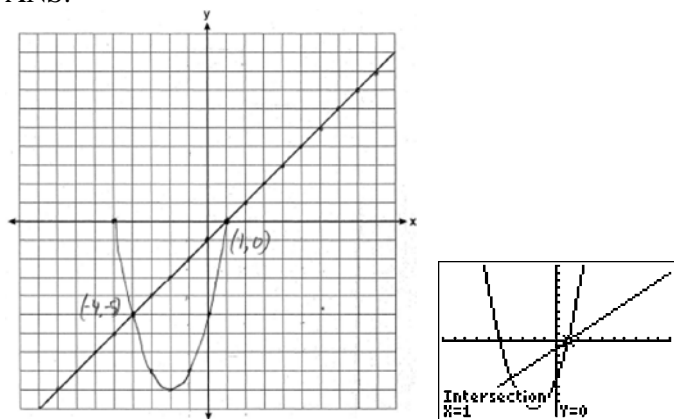

PTS: 4

REF: 080839ia

STA: A.G.9

TOP: Quadratic-Linear Systems

609 ANS:

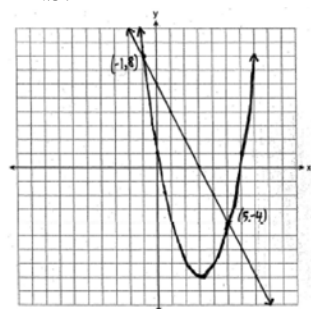

PTS: 4

REF: 060939ia

STA: A.G.9

TOP: Quadratic-Linear Systems

610 ANS: 2

PTS: 2

REF: 011012ia

STA: A.G.9

TOP: Quadratic-Linear Systems

611 ANS:

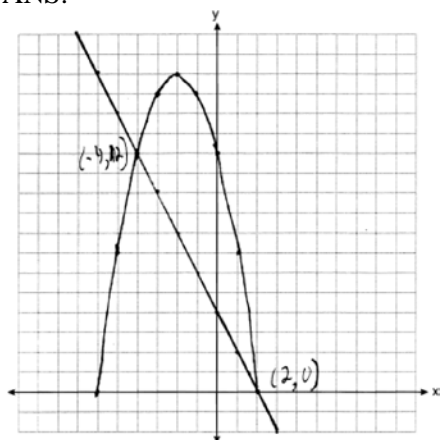

PTS: 4 REF: 061039ia STA: A.G.9 TOP: Quadratic-Linear Systems

612 ANS: 1

$$2y - 2x = 10 \quad \text{axis of symmetry: } x = \frac{-b}{2a} = \frac{-2}{2(1)} = -1$$

$$2y = 2x + 10$$

$$y = x + 5$$

PTS: 2 REF: 081010ia STA: A.G.9 TOP: Quadratic-Linear Systems

613 ANS: 4 PTS: 2 REF: 011102ia STA: A.G.9

TOP: Quadratic-Linear Systems

614 ANS:

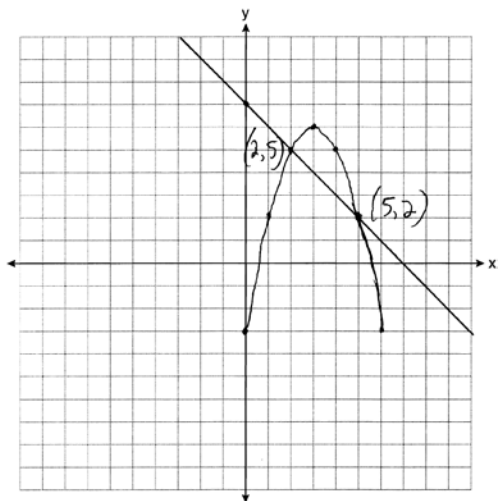

PTS: 4 REF: 081138ia STA: A.G.9 TOP: Quadratic-Linear Systems

615 ANS: 1 PTS: 2 REF: 011207ia STA: A.G.9

TOP: Quadratic-Linear Systems

616 ANS:

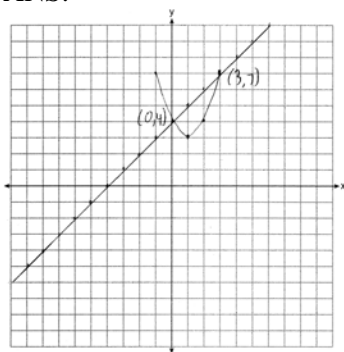

PTS: 4

REF: 011339ia

STA: A.G.9

TOP: Quadratic-Linear Systems

617 ANS: 1

$$x^2 - 5x + 3 = x - 6 \quad y = 3 - 6 = -3 \quad (3, -3)$$

$$x^2 - 6x + 9 = 0$$

$$(x - 3)^2 = 0$$

$$x = 3$$

PTS: 2

REF: 061330ia

STA: A.G.9

TOP: Quadratic-Linear Systems

618 ANS:

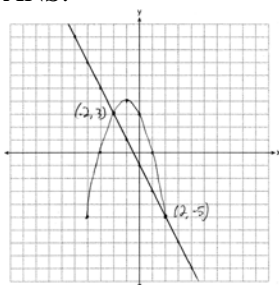

PTS: 4

REF: 081337ia

STA: A.G.9

TOP: Quadratic-Linear Systems

619 ANS:

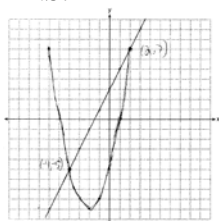

PTS: 4

REF: 011437ia

STA: A.G.9

TOP: Quadratic-Linear Systems

620 ANS: 4

$$-3x(x - 4) - 2x(x + 3) = -3x^2 + 12x - 2x^2 - 6x = -5x^2 + 6x$$

PTS: 2

REF: 081114ia

STA: A.A.13

TOP: Addition and Subtraction of Monomials

621 ANS: 3

PTS: 2

REF: 080819ia

STA: A.A.13

TOP: Addition and Subtraction of Polynomials

KEY: subtraction

- 622 ANS: 2 PTS: 2 REF: 060923ia STA: A.A.13
TOP: Addition and Subtraction of Polynomials KEY: subtraction
- 623 ANS: 3 PTS: 2 REF: 061003ia STA: A.A.13
TOP: Addition and Subtraction of Polynomials KEY: addition
- 624 ANS: 1 PTS: 2 REF: 011126ia STA: A.A.13
TOP: Addition and Subtraction of Polynomials KEY: subtraction
- 625 ANS: 4 PTS: 2 REF: 061130ia STA: A.A.13
TOP: Addition and Subtraction of Polynomials KEY: subtraction
- 626 ANS: 1 PTS: 2 REF: 011213ia STA: A.A.13
TOP: Addition and Subtraction of Polynomials KEY: addition
- 627 ANS: 4 PTS: 2 REF: 061226ia STA: A.A.13
TOP: Addition and Subtraction of Polynomials KEY: subtraction
- 628 ANS: 2 PTS: 2 REF: 081205ia STA: A.A.13
TOP: Addition and Subtraction of Polynomials KEY: addition
- 629 ANS: 1 PTS: 2 REF: 061322ia STA: A.A.13
TOP: Addition and Subtraction of Polynomials KEY: subtraction
- 630 ANS: 1 PTS: 2 REF: 081302ia STA: A.A.13
TOP: Addition and Subtraction of Polynomials KEY: addition
- 631 ANS: 4 PTS: 2 REF: 011429ia STA: A.A.13
TOP: Addition and Subtraction of Polynomials KEY: subtraction
- 632 ANS: 2 PTS: 2 REF: 061414ia STA: A.A.13
TOP: Addition and Subtraction of Polynomials KEY: subtraction
- 633 ANS: 4 PTS: 2 REF: 081428ia STA: A.A.13
TOP: Addition and Subtraction of Polynomials KEY: subtraction
- 634 ANS: 1 PTS: 2 REF: 060807ia STA: A.A.13
TOP: Multiplication of Polynomials
- 635 ANS: 3
 $(3x + 2)(x - 7) = 3x^2 - 21x + 2x - 14 = 3x^2 - 19x - 14$
- PTS: 2 REF: 061210ia STA: A.A.13 TOP: Multiplication of Polynomials
- 636 ANS:
 $P = 2(x^2 + 3x + 2) + 2(4x) = 2x^2 + 6x + 4 + 8x = 2x^2 + 14x + 4$ $A = 4x(x^2 + 3x + 2) = 4x^3 + 12x^2 + 8x$
- PTS: 4 REF: 061538ia STA: A.A.13 TOP: Multiplication of Polynomials
- 637 ANS: 3
 $\frac{12x^3 - 6x^2 + 2x}{2x} = \frac{2x(6x^2 - 3x + 1)}{2x} = 6x^2 - 3x + 1$
- PTS: 2 REF: 011011ia STA: A.A.14 TOP: Division of Polynomials
- 638 ANS:
 $3a^2b^2 - 6a \cdot \frac{45a^4b^3 - 90a^3b}{15a^2b} = \frac{45a^4b^3}{15a^2b} - \frac{90a^3b}{15a^2b} = 3a^2b^2 - 6a$
- PTS: 2 REF: 081031ia STA: A.A.14 TOP: Division of Polynomials
- 639 ANS: 4 PTS: 2 REF: 061203ia STA: A.A.14
TOP: Division of Polynomials

- 640 ANS: 2 PTS: 2 REF: 011316ia STA: A.A.14
TOP: Division of Polynomials
- 641 ANS: 4 PTS: 2 REF: 011412ia STA: A.A.14
TOP: Division of Polynomials
- 642 ANS: 4 PTS: 2 REF: 080903ia STA: A.A.12
TOP: Multiplication of Powers
- 643 ANS: 4 PTS: 2 REF: 011020ia STA: A.A.12
TOP: Multiplication of Powers
- 644 ANS: 3 PTS: 2 REF: 061401ia STA: A.A.12
TOP: Multiplication of Powers
- 645 ANS: 4 PTS: 2 REF: 081401ia STA: A.A.12
TOP: Multiplication of Powers
- 646 ANS: 3
$$\frac{(2x^3)(8x^5)}{4x^6} = \frac{16x^8}{4x^6} = 4x^2$$
- PTS: 2 REF: fall0703ia STA: A.A.12 TOP: Division of Powers
- 647 ANS: 4
$$\frac{2^6}{2^1} = 2^5$$
- PTS: 2 REF: 060813ia STA: A.A.12 TOP: Division of Powers
- 648 ANS:
$$\frac{3k^2m^6}{4}$$
- PTS: 2 REF: 010932ia STA: A.A.12 TOP: Division of Powers
- 649 ANS: 1 PTS: 2 REF: 060903ia STA: A.A.12
TOP: Division of Powers
- 650 ANS: 4 PTS: 2 REF: 061018ia STA: A.A.12
TOP: Division of Powers
- 651 ANS: 1 PTS: 2 REF: 061103ia STA: A.A.12
TOP: Division of Powers
- 652 ANS: 3
$$\frac{3^6}{3^1} = 3^5$$
- PTS: 2 REF: 061219ia STA: A.A.12 TOP: Division of Powers
- 653 ANS: 2 PTS: 2 REF: 081311ia STA: A.A.12
TOP: Division of Powers
- 654 ANS: 4 PTS: 2 REF: 011503ia STA: A.A.12
TOP: Division of Powers
- 655 ANS: 4 PTS: 2 REF: 080827ia STA: A.A.12
TOP: Powers of Powers

656 ANS: 3

$$\frac{(10w^3)^2}{5w} = \frac{100w^6}{5w} = 20w^5$$

PTS: 2 REF: 011124ia STA: A.A.12 TOP: Powers of Powers

657 ANS: 4

$$\frac{(4x^3)^2}{2x} = \frac{16x^6}{2x} = 8x^5$$

PTS: 2 REF: 011216ia STA: A.A.12 TOP: Powers of Powers

658 ANS: 2 PTS: 2 REF: 061312ia STA: A.A.12
TOP: Powers of Powers659 ANS: 2 PTS: 2 REF: 081318ia STA: A.A.12
TOP: Powers of Powers660 ANS: 2 PTS: 2 REF: fall0725ia STA: A.N.4
TOP: Operations with Scientific Notation661 ANS: 4 PTS: 2 REF: 010927ia STA: A.N.4
TOP: Operations with Scientific Notation662 ANS: 4 PTS: 2 REF: 060927ia STA: A.N.4
TOP: Operations with Scientific Notation

663 ANS: 4

$$\frac{9.2 \times 10^6}{2.3 \times 10^2} = 4 \times 10^4$$

PTS: 2 REF: 081006ia STA: A.N.4 TOP: Operations with Scientific Notation

664 ANS: 2 PTS: 2 REF: 061127ia STA: A.N.4
TOP: Operations with Scientific Notation

665 ANS:

$$6.56 \times 10^{-2}$$

PTS: 2 REF: 081231ia STA: A.N.4 TOP: Operations with Scientific Notation

666 ANS: 3 PTS: 2 REF: 011319ia STA: A.N.4
TOP: Operations with Scientific Notation667 ANS: 3 PTS: 2 REF: 061430ia STA: A.N.4
TOP: Operations with Scientific Notation

668 ANS: 2

$$\frac{26.6 \times 10^8}{3.5 \times 10^3} = 7.6 \times 10^5$$

PTS: 2 REF: 061527ia STA: A.N.4 TOP: Operations with Scientific Notation

669 ANS: 3

$$35000(1 - 0.05)^4 \approx 28507.72$$

PTS: 2 REF: fall0719ia STA: A.A.9 TOP: Exponential Functions

- 670 ANS: 2 PTS: 2 REF: 060830ia STA: A.A.9
TOP: Exponential Functions
- 671 ANS: 4 PTS: 2 REF: 010908ia STA: A.A.9
TOP: Exponential Functions
- 672 ANS:
 $5,583.86. A = P(1 + R)^t = 5000(1 + 0.0375)^3 \approx 5583.86$
- PTS: 3 REF: 060935ia STA: A.A.9 TOP: Exponential Functions
- 673 ANS: 3
 $500(1 + 0.06)^3 \approx 596$
- PTS: 2 REF: 080929ia STA: A.A.9 TOP: Exponential Functions
- 674 ANS: 2
 $R = 0.5^{d-1}$
- PTS: 2 REF: 011006ia STA: A.A.9 TOP: Exponential Functions
- 675 ANS: 1
 $15000(1.2)^{\frac{6}{3}} = 21,600. 21,600 - 15,000 = 6,600$
- PTS: 2 REF: 061030ia STA: A.A.9 TOP: Exponential Functions
- 676 ANS:
 $24,435.19. 30000(.95)^4 \approx 24435.19$
- PTS: 4 REF: 011138ia STA: A.A.9 TOP: Exponential Functions
- 677 ANS: 2
 $20000(.88)^3 = 13629.44$
- PTS: 2 REF: 061124ia STA: A.A.9 TOP: Exponential Functions
- 678 ANS: 2
 $2000(1 + 0.04)^3 \approx 2249$
- PTS: 2 REF: 081124ia STA: A.A.9 TOP: Exponential Functions
- 679 ANS: 1 PTS: 2 REF: 011202ia STA: A.A.9
TOP: Exponential Functions
- 680 ANS: 2 PTS: 2 REF: 061229ia STA: A.A.9
TOP: Exponential Functions
- 681 ANS: 3 PTS: 2 REF: 081211ia STA: A.A.9
TOP: Exponential Functions
- 682 ANS: 3 PTS: 2 REF: 011310ia STA: A.A.9
TOP: Exponential Functions
- 683 ANS:
 $A = P(1 + R)^t = 2000(1 + 0.035)^4 \approx 2295$
- PTS: 2 REF: 081333ia STA: A.A.9 TOP: Exponential Functions

684 ANS:

$$1000(1.03)^5 \approx 1159.27$$

PTS: 3

REF: 011433ia

STA: A.A.9

TOP: Exponential Functions

685 ANS: 3

$$36500(1.07)^{20} \approx 141243$$

PTS: 2

REF: 081422ia

STA: A.A.9

TOP: Exponential Functions

686 ANS:

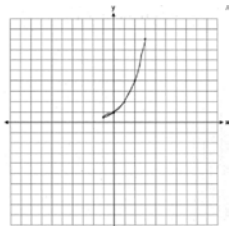

. The graph will never intersect the x -axis as $2^x > 0$ for all values of x .

PTS: 3

REF: 080835ia

STA: A.G.4

TOP: Graphing Exponential Functions

687 ANS:

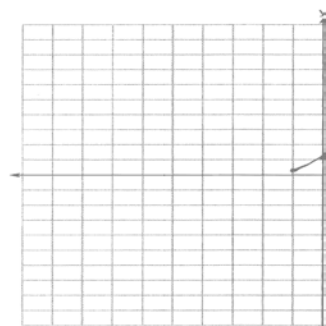

PTS: 2

REF: 081233ia

STA: A.G.4

TOP: Graphing Exponential Functions

688 ANS: 4

PTS: 2

REF: 011423ia

STA: A.G.4

TOP: Graphing Exponential Functions

689 ANS:

$$30\sqrt{2} \cdot 5\sqrt{72} = 5\sqrt{36} \sqrt{2} = 30\sqrt{2}$$

PTS: 2

REF: fall0731ia

STA: A.N.2

TOP: Simplifying Radicals

690 ANS: 1

$$\frac{\sqrt{32}}{4} = \frac{\sqrt{16} \sqrt{2}}{4} = \sqrt{2}$$

PTS: 2

REF: 060828ia

STA: A.N.2

TOP: Simplifying Radicals

691 ANS: 3

$$\sqrt{72} = \sqrt{36} \sqrt{2} = 6\sqrt{2}$$

PTS: 2

REF: 010920ia

STA: A.N.2

TOP: Simplifying Radicals

- 692 ANS: 2
 $\sqrt{32} = \sqrt{16} \sqrt{2} = 4\sqrt{2}$
 PTS: 2 REF: 060910ia STA: A.N.2 TOP: Simplifying Radicals
- 693 ANS: 2
 $5\sqrt{20} = 5\sqrt{4} \sqrt{5} = 10\sqrt{5}$
 PTS: 2 REF: 080922ia STA: A.N.2 TOP: Simplifying Radicals
- 694 ANS:
 $-3\sqrt{48} = -3\sqrt{16} \sqrt{3} = -12\sqrt{3}$
 PTS: 2 REF: 081033ia STA: A.N.2 TOP: Simplifying Radicals
- 695 ANS: 3
 $3\sqrt{250} = 3\sqrt{25} \sqrt{10} = 15\sqrt{10}$
 PTS: 2 REF: 061106ia STA: A.N.2 TOP: Simplifying Radicals
- 696 ANS: 3
 $2\sqrt{45} = 2\sqrt{9} \sqrt{5} = 6\sqrt{5}$
 PTS: 2 REF: 011203ia STA: A.N.2 TOP: Simplifying Radicals
- 697 ANS:
 $4\sqrt{75} = 4\sqrt{25} \sqrt{3} = 20\sqrt{3}$
 PTS: 2 REF: 011331ia STA: A.N.2 TOP: Simplifying Radicals
- 698 ANS:
 $2\sqrt{108} = 2\sqrt{36} \sqrt{3} = 12\sqrt{3}$
 PTS: 2 REF: 081332ia STA: A.N.2 TOP: Simplifying Radicals
- 699 ANS:
 $60 - 42\sqrt{5} \cdot 3\sqrt{20}(2\sqrt{5} - 7) = 6\sqrt{100} - 21\sqrt{20} = 60 - 21\sqrt{4} \sqrt{5} = 60 - 42\sqrt{5}$
 PTS: 3 REF: 080834ia STA: A.N.3 TOP: Operations with Radicals
 KEY: mixed
- 700 ANS: 4
 $6\sqrt{50} + 6\sqrt{2} = 6\sqrt{25} \sqrt{2} + 6\sqrt{2} = 30\sqrt{2} + 6\sqrt{2} = 36\sqrt{2}$
 PTS: 2 REF: 011024ia STA: A.N.3 TOP: Operations with Radicals
 KEY: addition
- 701 ANS: 3
 $\sqrt{72} - 3\sqrt{2} = \sqrt{36} \sqrt{2} - 3\sqrt{2} = 6\sqrt{2} - 3\sqrt{2} = 3\sqrt{2}$
 PTS: 2 REF: 061008ia STA: A.N.3 TOP: Operations with Radicals
 KEY: subtraction

702 ANS: 3

$$3\sqrt{2} + \sqrt{8} = 3\sqrt{2} + \sqrt{4}\sqrt{2} = 3\sqrt{2} + 2\sqrt{2} = 5\sqrt{2}$$

PTS: 2 REF: 011121ia STA: A.N.3 TOP: Operations with Radicals
KEY: addition

703 ANS:

$$-2\sqrt{3} \frac{16\sqrt{21}}{2\sqrt{7}} - 5\sqrt{12} = 8\sqrt{3} - 5\sqrt{4}\sqrt{3} = 8\sqrt{3} - 10\sqrt{3} = -2\sqrt{3}$$

PTS: 3 REF: 081136ia STA: A.N.3 TOP: Operations with Radicals
KEY: mixed

704 ANS:

$$6\sqrt{3} \frac{3\sqrt{75} + \sqrt{27}}{3} = \frac{3\sqrt{25}\sqrt{3} + \sqrt{9}\sqrt{3}}{3} = \frac{15\sqrt{3} + 3\sqrt{3}}{3} = \frac{18\sqrt{3}}{3} = 6\sqrt{3}$$

PTS: 3 REF: 061236ia STA: A.N.3 TOP: Operations with Radicals
KEY: addition

705 ANS:

$$5 - 2\sqrt{3} + \sqrt{9}\sqrt{3} + 2(3) = 5 - 2\sqrt{3} + 3\sqrt{3} + 6 = 11 + \sqrt{3}$$

PTS: 3 REF: 061336ia STA: A.N.3 TOP: Operations with Radicals
KEY: subtraction

706 ANS:

$$\frac{\sqrt{84}}{2\sqrt{3}} = \frac{\sqrt{4}\sqrt{21}}{2\sqrt{3}} = \sqrt{\frac{21}{3}} = \sqrt{7}$$

PTS: 2 REF: 011431ia STA: A.N.3 TOP: Operations with Radicals
KEY: division

707 ANS:

$$3\sqrt{7}(\sqrt{7}\sqrt{2} + 4\sqrt{7}\sqrt{4}\sqrt{2}) = 21\sqrt{2} + 168\sqrt{2} = 189\sqrt{2}$$

PTS: 3 REF: 061436ia STA: A.N.3 TOP: Operations with Radicals
KEY: mixed

708 ANS:

$$y\sqrt{3} - 4\sqrt{2} - 3y\sqrt{3} = -2y\sqrt{3} - 4\sqrt{2}$$

PTS: 3 REF: 081436ia STA: A.N.3 TOP: Operations with Radicals
KEY: subtraction

709 ANS: 1

$$\sqrt{150} + \sqrt{24} = \sqrt{25}\sqrt{6} + \sqrt{4}\sqrt{6} = 5\sqrt{6} + 2\sqrt{6} = 7\sqrt{6}$$

PTS: 2 REF: 011517ia STA: A.N.3 TOP: Operations with Radicals
KEY: addition

710 ANS: 1

$$4\sqrt{2} \cdot 2\sqrt{6} = 8\sqrt{12} = 8\sqrt{4} \cdot \sqrt{3} = 16\sqrt{3}$$

PTS: 2 REF: 061528ia STA: A.N.3 TOP: Operations with Radicals
KEY: multiplication

711 ANS: 2

$$\frac{9x^4 - 27x^6}{3x^3} = \frac{9x^4(1 - 3x^2)}{3x^3} = 3x(1 - 3x^2)$$

PTS: 2 REF: fall0718ia STA: A.A.16 TOP: Rational Expressions
KEY: $a > 0$

712 ANS: 2

$$\frac{2x^2 - 12x}{x - 6} = \frac{2x(x - 6)}{x - 6} = 2x$$

PTS: 2 REF: 060824ia STA: A.A.16 TOP: Rational Expressions
KEY: $a > 0$

713 ANS: 4

$$\frac{25x - 125}{x^2 - 25} = \frac{25(x - 5)}{(x + 5)(x - 5)} = \frac{25}{x + 5}$$

PTS: 2 REF: 080821ia STA: A.A.16 TOP: Rational Expressions
KEY: $a > 0$

714 ANS: 2

$$\frac{x^2 - 2x - 15}{x^2 + 3x} = \frac{(x - 5)(x + 3)}{x(x + 3)} = \frac{x - 5}{x}$$

PTS: 2 REF: 060921ia STA: A.A.16 TOP: Rational Expressions
KEY: $a > 0$

715 ANS: 1

$$\frac{x^2 - x - 6}{x^2 - 5x + 6} = \frac{(x - 3)(x + 2)}{(x - 3)(x + 2)} = \frac{x + 2}{x - 2}$$

PTS: 2 REF: 011130ia STA: A.A.16 TOP: Rational Expressions
KEY: $a > 0$

716 ANS:

$$\frac{x^2 - 5x - 24}{x - 8} = \frac{(x - 8)(x + 3)}{x - 8} = x + 3$$

PTS: 2 REF: 061131ia STA: A.A.16 TOP: Rational Expressions
KEY: $a > 0$

717 ANS:

$$\frac{x-1}{x+2} \cdot \frac{x^2-1}{x^2+3x+2} = \frac{(x+1)(x-1)}{(x+2)(x+1)}$$

PTS: 2 REF: 011233ia STA: A.A.16 TOP: Rational Expressions
KEY: a > 0

718 ANS: 2

$$\frac{x^2-3x-10}{x^2-25} = \frac{(x-5)(x+2)}{(x+5)(x-5)} = \frac{x+2}{x+5}$$

PTS: 2 REF: 061216ia STA: A.A.16 TOP: Rational Expressions
KEY: a > 0

719 ANS: 4

$$\frac{2x^2(x^4-9x^2+1)}{2x^2}$$

PTS: 2 REF: 081222ia STA: A.A.16 TOP: Rational Expressions
KEY: a > 0

720 ANS: 1

$$\frac{2x^2+10x-28}{4x+28} = \frac{2(x^2+5x-14)}{4x+28} = \frac{2(x+7)(x-2)}{4(x+7)} = \frac{x-2}{2}$$

PTS: 2 REF: 011327ia STA: A.A.16 TOP: Rational Expressions
KEY: a > 0

721 ANS: 1

$$\frac{(x+5)(x+3)}{x+5} = x+3$$

PTS: 2 REF: 0613071a STA: A.A.16 TOP: Rational Expressions
KEY: a > 0

722 ANS: 3

$$\frac{x^2-25}{x^2-x-20} = \frac{(x+5)(x-5)}{(x+4)(x-5)} = \frac{x+5}{x+4}$$

PTS: 2 REF: 011424ia STA: A.A.16 TOP: Rational Expressions
KEY: a > 0

723 ANS: 1 PTS: 2 REF: fall0728ia STA: A.A.15
TOP: Undefined Rationals

724 ANS: 3 PTS: 2 REF: 060817ia STA: A.A.15
TOP: Undefined Rationals

725 ANS: 2 PTS: 2 REF: 010925ia STA: A.A.15
TOP: Undefined Rationals

726 ANS: 4 PTS: 2 REF: 060916ia STA: A.A.15
TOP: Undefined Rationals

- 727 ANS: 1
 $x^2 + 7x + 10 = 0$
 $(x + 5)(x + 2) = 0$
 $x = -5$ or -2
- PTS: 2 REF: 080918ia STA: A.A.15 TOP: Undefined Rationals
- 728 ANS: 3
 $x^2 - 9 = 0$
 $(x + 3)(x - 3) = 0$
 $x = \pm 3$
- PTS: 2 REF: 061014ia STA: A.A.15 TOP: Undefined Rationals
- 729 ANS: 4
 $x^2 - 4x - 12 = 0$
 $(x - 6)(x + 2) = 0$
 $x = 6$ $x = -2$
- PTS: 2 REF: 061125ia STA: A.A.15 TOP: Undefined Rationals
- 730 ANS: 1
 $x^2 + 5x - 6 = 0$
 $(x + 6)(x - 1) = 0$
 $x = -6, 1$
- PTS: 2 REF: 011214ia STA: A.A.15 TOP: Undefined Rationals
- 731 ANS: 3
 $x^2 - 4 = 0$
 $(x + 2)(x - 2) = 0$
 $x = \pm 2$
- PTS: 2 REF: 081225ia STA: A.A.15 TOP: Undefined Rationals
- 732 ANS: 1 PTS: 2 REF: 061315ia STA: A.A.15
TOP: Undefined Rationals
- 733 ANS: 4
 $x^2 - 2x - 15 = 0$
 $(x + 3)(x - 5) = 0$
 $x = -3, 5$
- PTS: 2 REF: 081316ia STA: A.A.15 TOP: Undefined Rationals
- 734 ANS: 2 PTS: 2 REF: 061429ia STA: A.A.15
TOP: Undefined Rationals

735 ANS: 2

$$4x + 28 = 0$$

$$4x = -28$$

$$x = -7$$

PTS: 2

REF: 081417ia

STA: A.A.15

TOP: Undefined Rationals

736 ANS: 4

PTS: 2

REF: 011521ia

STA: A.A.15

TOP: Undefined Rationals

737 ANS: 2

PTS: 2

REF: 061520ia

STA: A.A.15

TOP: Undefined Rationals

738 ANS: 4

$$\frac{x^2 - 1}{x + 1} \cdot \frac{x + 3}{3x - 3} = \frac{(x + 1)(x - 1)}{x + 1} \cdot \frac{x + 3}{3(x - 1)} = \frac{x + 3}{3}$$

PTS: 2

REF: 060815ia

STA: A.A.18

TOP: Multiplication and Division of Rationals

KEY: multiplication

Integrated Algebra Regents Exam Questions by Performance Indicator: Topic Answer Section

739 ANS: 1

$$\frac{4x}{x-1} \cdot \frac{x^2-1}{3x+3} = \frac{4x}{x-1} \cdot \frac{(x+1)(x-1)}{3(x+1)} = \frac{4x}{3}$$

PTS: 2 REF: 080826ia STA: A.A.18 TOP: Multiplication and Division of Rationals
KEY: multiplication

740 ANS:

$$\frac{3}{4x-8} \cdot \frac{3x+6}{4x+12} \div \frac{x^2-4}{x+3} = \frac{3(x+2)}{4(x+3)} \cdot \frac{x+3}{(x+2)(x-2)} = \frac{3}{4(x-2)}$$

PTS: 3 REF: 010935ia STA: A.A.18 TOP: Multiplication and Division of Rationals
KEY: division

741 ANS:

$$\frac{x-7}{3x} \cdot \frac{2x^2-8x-42}{6x^2} \div \frac{x^2-9}{x^2-3x} = \frac{2(x^2-4x-21)}{6x^2} \cdot \frac{x(x-3)}{(x+3)(x-3)} = \frac{(x-7)(x+3)}{3x} \cdot \frac{1}{x+3} = \frac{x-7}{3x}$$

PTS: 4 REF: 080937ia STA: A.A.18 TOP: Multiplication and Division of Rationals
KEY: division

742 ANS:

$$\frac{x^2+9x+14}{x^2-49} \div \frac{3x+6}{x^2+x-56} = \frac{(x+7)(x+2)}{(x+7)(x-7)} \cdot \frac{(x+8)(x-7)}{3(x+2)} = \frac{x+8}{3}$$

PTS: 4 REF: 061037ia STA: A.A.18 TOP: Multiplication and Division of Rationals
KEY: division

743 ANS: 4

$$\frac{x}{x+4} \div \frac{2x}{x^2-16} = \frac{x}{x+4} \cdot \frac{x^2-16}{2x} = \frac{1}{x+4} \cdot \frac{(x+4)(x-4)}{2} = \frac{x-4}{2}$$

PTS: 2 REF: 081130ia STA: A.A.18 TOP: Multiplication and Division of Rationals
KEY: division

744 ANS:

$$\frac{x+2}{2} \times \frac{4(x+5)}{(x+4)(x+2)} = \frac{2(x+5)}{x+4}$$

PTS: 2 REF: 081232ia STA: A.A.18 TOP: Multiplication and Division of Rationals
KEY: multiplication

745 ANS:

$$\frac{3x(x+3)}{(x+3)(x+2)} \times \frac{(x-3)(x+2)}{(x+3)(x-3)} = \frac{3x}{x+3}$$

PTS: 4 REF: 081338ia STA: A.A.18 TOP: Multiplication and Division of Rationals
KEY: division

746 ANS:

$$\left(\frac{10x^2y}{x^2 + xy} \right) \cdot \left(\frac{(x+y)^2}{2x} \right) \div \left(\frac{x^2 - y^2}{5y^2} \right) = \left(\frac{10x^2y}{x(x+y)} \right) \cdot \left(\frac{(x+y)^2}{2x} \right) \cdot \left(\frac{5y^2}{(x+y)(x-y)} \right) = \frac{25y^3}{x-y}$$

PTS: 4 REF: 011539ia STA: A.A.18 TOP: Multiplication and Division of Rationals
KEY: division

747 ANS: 4

$$\frac{(d \times 3) + (2 \times 2d)}{2 \times 3} = \frac{3d + 4d}{6} = \frac{7d}{6}$$

PTS: 2 REF: fall0727ia STA: A.A.17 TOP: Addition and Subtraction of Rationals

748 ANS: 2

$$\frac{6}{5x} - \frac{2}{3x} = \frac{18x - 10x}{15x^2} = \frac{8x}{15x^2} = \frac{8}{15x}$$

PTS: 2 REF: 010921ia STA: A.A.17 TOP: Addition and Subtraction of Rationals

749 ANS: 2

$$\frac{6}{4a} - \frac{2}{3a} = \frac{18a - 8a}{12a^2} = \frac{10a}{12a^2} = \frac{5}{6a}$$

PTS: 2 REF: 060929ia STA: A.A.17 TOP: Addition and Subtraction of Rationals

750 ANS: 2

$$\frac{3}{2x} + \frac{4}{3x} = \frac{9x + 8x}{6x^2} = \frac{17x}{6x^2} = \frac{17}{6x}$$

PTS: 2 REF: 080917ia STA: A.A.17 TOP: Addition and Subtraction of Rationals

751 ANS: 4 PTS: 2 REF: 011025ia
TOP: Addition and Subtraction of Rationals

STA: A.A.17

752 ANS: 1 PTS: 2 REF: 061024ia
TOP: Addition and Subtraction of Rationals

STA: A.A.17

753 ANS: 3

$$\frac{2+x}{5x} - \frac{x-2}{5x} = \frac{2+x-x+2}{5x} = \frac{4}{5x}$$

PTS: 2 REF: 081027ia STA: A.A.17 TOP: Addition and Subtraction of Rationals

754 ANS: 2

$$\frac{3}{2x} + \frac{7}{4x} = \frac{12x + 14x}{8x^2} = \frac{26x}{8x^2} = \frac{13}{4x}$$

PTS: 2 REF: 011120ia STA: A.A.17 TOP: Addition and Subtraction of Rationals

755 ANS: 4

$$\frac{7}{12x} - \frac{y}{6x^2} = \frac{42x^2 - 12xy}{72x^3} = \frac{6x(7x - 2y)}{72x^3} = \frac{7x - 2y}{12x^2}$$

PTS: 2 REF: 061129ia STA: A.A.17 TOP: Addition and Subtraction of Rationals

756 ANS: 2

$$\frac{2y}{y+5} + \frac{10}{y+5} = \frac{2y+10}{y+5} = \frac{2(y+5)}{y+5} = 2$$

PTS: 2 REF: 011230ia STA: A.A.17 TOP: Addition and Subtraction of Rationals

757 ANS: 1 PTS: 2 REF: 061220ia STA: A.A.17

TOP: Addition and Subtraction of Rationals

758 ANS: 3

$$\frac{4}{3a} - \frac{5}{2a} = \frac{8}{6a} - \frac{15}{6a} = -\frac{7}{6a}$$

PTS: 2 REF: 081328ia STA: A.A.17 TOP: Addition and Subtraction of Rationals

759 ANS: 3

$$\frac{2n}{5} + \frac{3n}{2} = \frac{4n+15n}{10} = \frac{19n}{10}$$

PTS: 2 REF: 011420ia STA: A.A.17 TOP: Addition and Subtraction of Rationals

760 ANS: 3 PTS: 2 REF: 061424ia STA: A.A.17

TOP: Addition and Subtraction of Rationals

761 ANS: 1 PTS: 2 REF: 081409ia STA: A.A.17

TOP: Addition and Subtraction of Rationals

762 ANS: 3

$$\frac{10}{7x} - \frac{3}{5x} = \frac{50x-21x}{35x^2} = \frac{29x}{35x^2} = \frac{29}{35x}$$

PTS: 2 REF: 011511ia STA: A.A.17 TOP: Addition and Subtraction of Rationals

763 ANS:

6, -2.

$$\frac{x+1}{x} = \frac{-7}{x-12}$$

$$(x+1)(x-12) = -7x$$

$$x^2 - 11x - 12 = -7x$$

$$x^2 - 4x - 12 = 0$$

$$(x-6)(x+2) = 0$$

$$x = 6 \text{ or } -2$$

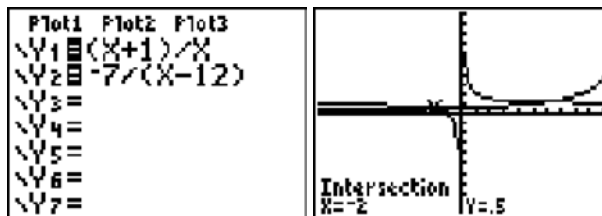

PTS: 4 REF: fall0739ia STA: A.A.26 TOP: Solving Rationals

764 ANS: 4

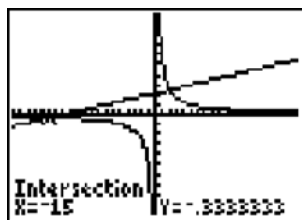

$$\frac{5}{x} = \frac{x+13}{6}$$

$$x^2 + 13x = 30$$

$$x^2 + 13x - 30 = 0$$

$$(x+15)(x-2) = 0$$

$$x = -15 \text{ or } 2$$

PTS: 2

REF: 060826ia

STA: A.A.26

TOP: Solving Rationals

765 ANS: 3

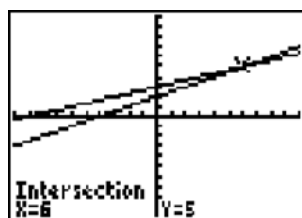

$$\frac{k+4}{2} = \frac{k+9}{3}$$

$$3(k+4) = 2(k+9)$$

$$3k + 12 = 2k + 18$$

$$k = 6$$

PTS: 2

REF: 010906ia

STA: A.A.26

TOP: Solving Rationals

766 ANS: 1

$$\frac{2}{x} - 3 = \frac{26}{x}$$

$$-3 = \frac{24}{x}$$

$$x = -8$$

PTS: 2

REF: 010918ia

STA: A.A.26

TOP: Solving Rationals

767 ANS: 4

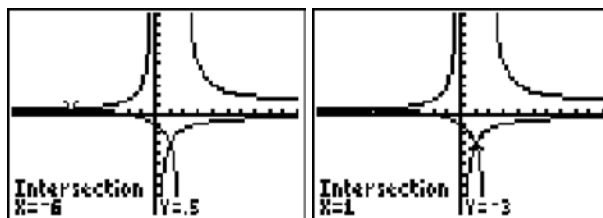

$$\frac{x+2}{x-2} = \frac{-3}{x}$$

$$x(x+2) = -3(x-2)$$

$$x^2 + 2x = -3x + 6$$

$$x^2 + 5x - 6 = 0$$

$$(x+6)(x-1) = 0$$

$$x = -6 \text{ or } 1$$

PTS: 2

REF: 011028ia

STA: A.A.26

TOP: Solving Rationals

768 ANS: 2

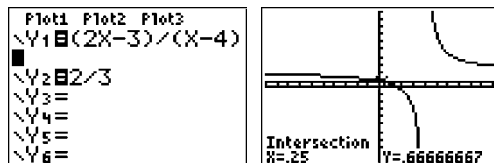

$$\frac{2x-3}{x-4} = \frac{2}{3}$$

$$3(2x-3) = 2(x-4)$$

$$6x - 9 = 2x - 8$$

$$4x = 1$$

$$x = \frac{1}{4}$$

PTS: 2

REF: 081012ia

STA: A.A.26

TOP: Solving Rationals

769 ANS:

$$4, -5. \quad \frac{x+2}{6} = \frac{3}{x-1}$$

$$(x+2)(x-1) = 18$$

$$x^2 - x + 2x - 2 = 18$$

$$x^2 + x - 20 = 0$$

$$(x+5)(x-4) = 0$$

$$x = -5 \text{ or } 4$$

PTS: 3

REF: 011136ia

STA: A.A.26

TOP: Solving Rationals

770 ANS:

$$-\frac{9}{4} \cdot \frac{3}{4} = \frac{-(x+11)}{4x} + \frac{1}{2x}$$

$$\frac{3}{4} = \frac{-x-11}{4x} + \frac{2}{4x}$$

$$\frac{3}{4} = \frac{-x-9}{4x}$$

$$12x = -4x - 36$$

$$16x = -36$$

$$x = -\frac{9}{4}$$

PTS: 4 REF: 061137ia STA: A.A.26 TOP: Solving Rationals

771 ANS: 3

$$\frac{2}{x+1} = \frac{x+1}{2}$$

$$x^2 + 2x + 1 = 4$$

$$x^2 + 2x - 3 = 0$$

$$(x+3)(x-1) = 3$$

$$x = -3, 1$$

PTS: 2 REF: 081226ia STA: A.A.26 TOP: Solving Rationals

772 ANS: 2

$$\frac{x+2}{2} = \frac{4}{x}$$

$$x^2 + 2x = 8$$

$$x^2 + 2x - 8 = 0$$

$$(x+4)(x-2) = 0$$

$$x = -4, 2$$

PTS: 2 REF: 061317ia STA: A.A.26 TOP: Solving Rationals

773 ANS:

$$\frac{2}{3x} + \frac{12}{3x} = \frac{7}{x+1}$$

$$\frac{14}{3x} = \frac{7}{x+1}$$

$$21x = 14x + 14$$

$$7x = 14$$

$$x = 2$$

PTS: 4 REF: 061337ia STA: A.A.26 TOP: Solving Rationals

774 ANS:

$$\frac{3}{x+5} = \frac{2x}{x^2-8}$$

$$3x^2 - 24 = 2x^2 + 10x$$

$$x^2 - 10x + 24 = 0$$

$$(x-12)(x+2) = 0$$

$$x = 12, -2$$

PTS: 4

REF: 011438ia

STA: A.A.26

TOP: Solving Rationals

775 ANS: 3

$$\frac{24}{14x} + \frac{21}{14x} = \frac{15x}{14x}$$

$$45 = 15x$$

$$x = 3$$

PTS: 2

REF: 081416ia

STA: A.A.26

TOP: Solving Rationals

776 ANS: 2

$$\frac{x}{3} = \frac{8}{x+2}$$

$$x^2 + 2x = 24$$

$$x^2 + 2x - 24 = 0$$

$$(x+6)(x-4) = 0$$

$$x = -6, 4$$

PTS: 2

REF: 081429ia

STA: A.A.26

TOP: Solving Rationals

777 ANS: 4

$$\frac{2}{x} = \frac{1}{3} - \frac{1}{5}$$

$$\frac{2}{x} = \frac{2}{15}$$

$$x = 15$$

PTS: 2

REF: 061507ia

STA: A.A.26

TOP: Solving Rationals

778 ANS: 4

PTS: 2

REF: fall0717ia

STA: A.G.4

TOP: Families of Functions

779 ANS: 1

PTS: 2

REF: 060801ia

STA: A.G.4

TOP: Families of Functions

780 ANS: 1

PTS: 2

REF: 010905ia

STA: A.G.4

TOP: Families of Functions

781 ANS: 4

PTS: 2

REF: 081025ia

STA: A.G.4

TOP: Families of Functions

782 ANS: 4

PTS: 2

REF: 061111ia

STA: A.G.4

TOP: Families of Functions

- 783 ANS: 3 PTS: 2 REF: 081118ia STA: A.G.4
TOP: Families of Functions
- 784 ANS: 3 PTS: 2 REF: 061318ia STA: A.G.4
TOP: Families of Functions
- 785 ANS: 2 PTS: 2 REF: 061423is STA: A.G.4
TOP: Families of Functions
- 786 ANS: 3 PTS: 2 REF: 080925ia STA: A.G.4
TOP: Identifying the Equation of a Graph
- 787 ANS: 4 PTS: 2 REF: 061221ia STA: A.G.4
TOP: Identifying the Equation of a Graph
- 788 ANS: 4 PTS: 2 REF: fall0730ia STA: A.G.3
TOP: Defining Functions KEY: graphs
- 789 ANS: 4 PTS: 2 REF: 010930ia STA: A.G.3
TOP: Defining Functions KEY: graphs
- 790 ANS: 3 PTS: 2 REF: 060919ia STA: A.G.3
TOP: Defining Functions KEY: graphs
- 791 ANS: 3
An element of the domain, 1, is paired with two different elements of the range, 3 and 7.

PTS: 2 REF: 080919ia STA: A.G.3 TOP: Defining Functions
KEY: ordered pairs
- 792 ANS: 4
In (4), each element in the domain corresponds to a unique element in the range.

PTS: 2 REF: 011018ia STA: A.G.3 TOP: Defining Functions
KEY: ordered pairs
- 793 ANS: 4 PTS: 2 REF: 061013ia STA: A.G.3
TOP: Defining Functions KEY: graphs
- 794 ANS: 4
In (4), each element in the domain corresponds to a unique element in the range.

PTS: 2 REF: 011105ia STA: A.G.3 TOP: Defining Functions
KEY: ordered pairs
- 795 ANS: 2
In (2), each element in the domain corresponds to a unique element in the range.

PTS: 2 REF: 061116ia STA: A.G.3 TOP: Defining Functions
KEY: ordered pairs
- 796 ANS: 3 PTS: 2 REF: 011204ia STA: A.G.3
TOP: Defining Functions KEY: graphs
- 797 ANS: 1 PTS: 2 REF: 061209ia STA: A.G.3
TOP: Defining Functions KEY: graphs
- 798 ANS: 3 PTS: 2 REF: 011309ia STA: A.G.3
TOP: Defining Functions KEY: graphs
- 799 ANS: 3 PTS: 2 REF: 081308ia STA: A.G.3
TOP: Defining Functions KEY: graphs

- 800 ANS: 4
An element of the domain, 1, is paired with two different elements of the range, 1 and -1 .
- PTS: 2 REF: 011405ia STA: A.G.3 TOP: Defining Functions
KEY: ordered pairs
- 801 ANS: 1 PTS: 2 REF: 061413ia STA: A.G.3
TOP: Defining Functions KEY: ordered pairs
- 802 ANS: 2 PTS: 2 REF: 011514ia STA: A.G.3
TOP: Defining Functions KEY: ordered pairs
- 803 ANS: 1
 $30^2 + 40^2 = c^2$. 30, 40, 50 is a multiple of 3, 4, 5.
 $2500 = c^2$
 $50 = c$
- PTS: 2 REF: fall0711ia STA: A.A.45 TOP: Pythagorean Theorem
804 ANS: 3 PTS: 2 REF: 060825ia STA: A.A.45
TOP: Pythagorean Theorem
- 805 ANS: 4
 $16^2 + b^2 = 34^2$
 $b^2 = 900$
 $b = 30$
- PTS: 2 REF: 080809ia STA: A.A.45 TOP: Pythagorean Theorem
806 ANS: 3
 $3^2 + 5^2 = x^2$
 $34 = x^2$
 $\sqrt{34} = x$
- PTS: 2 REF: 060909ia STA: A.A.45 TOP: Pythagorean Theorem
807 ANS: 1
 $8^2 + 15^2 = c^2$
 $c^2 = 289$
 $c = 17$
- PTS: 2 REF: 080906ia STA: A.A.45 TOP: Pythagorean Theorem
808 ANS: 2
 $\sqrt{5^2 + 7^2} \approx 8.6$
- PTS: 2 REF: 081004ia STA: A.A.45 TOP: Pythagorean Theorem

- 809 ANS: 2
 $\sqrt{18.4^2 - 7^2} \approx 17$
 PTS: 2 REF: 011107ia STA: A.A.45 TOP: Pythagorean Theorem
- 810 ANS: 3
 $10^2 + 10^2 = c^2$
 $c^2 = 200$
 $c \approx 14.1$
 PTS: 2 REF: 061102ia STA: A.A.45 TOP: Pythagorean Theorem
- 811 ANS: 1
 $\sqrt{1700^2 - 1300^2} \approx 1095$
 PTS: 2 REF: 011221ia STA: A.A.45 TOP: Pythagorean Theorem
- 812 ANS: 2
 $13^2 + 13^2 = x^2$
 $338 = x^2$
 $\sqrt{338} = x$
 $18 \approx x$
 PTS: 2 REF: 061223ia STA: A.A.45 TOP: Pythagorean Theorem
- 813 ANS: 3
 $\sqrt{8^2 - 6^2} = \sqrt{28} = \sqrt{4} \sqrt{7} = 2\sqrt{7}$
 PTS: 2 REF: 061329ia STA: A.A.45 TOP: Pythagorean Theorem
- 814 ANS: 3
 $\sqrt{13^2 - 7^2} = \sqrt{120}$
 PTS: 2 REF: 081323ia STA: A.A.45 TOP: Pythagorean Theorem
- 815 ANS: 2
 $\sqrt{48^2 + 40^2} = \sqrt{2304 + 1600} = \sqrt{3904} \approx 62$
 PTS: 2 REF: 011417ia STA: A.A.45 TOP: Pythagorean Theorem
- 816 ANS: 1 PTS: 2 REF: 061415ia STA: A.A.45
 TOP: Pythagorean Theorem
- 817 ANS: 1
 $7^2 + 24^2 = 25^2$
 PTS: 2 REF: 011526ia STA: A.A.45 TOP: Pythagorean Theorem

818 ANS: 1

$$\sin C = \frac{\text{opposite}}{\text{hypotenuse}} = \frac{13}{85}$$

PTS: 2 REF: fall0721ia STA: A.A.42 TOP: Trigonometric Ratios

819 ANS: 2

$$\sin U = \frac{\text{opposite}}{\text{hypotenuse}} = \frac{15}{17}$$

PTS: 2 REF: 010919ia STA: A.A.42 TOP: Trigonometric Ratios

820 ANS: 3

$$\cos A = \frac{\text{adjacent}}{\text{hypotenuse}} = \frac{15}{17}$$

PTS: 2 REF: 011008ia STA: A.A.42 TOP: Trigonometric Ratios

821 ANS: 2

$$\tan A = \frac{\text{opposite}}{\text{adjacent}} = \frac{14}{48}$$

PTS: 2 REF: 061009ia STA: A.A.42 TOP: Trigonometric Ratios

822 ANS: 2

$$\tan B = \frac{\text{opposite}}{\text{adjacent}} = \frac{8}{15} = 0.\overline{53}$$

PTS: 2 REF: 081026ia STA: A.A.42 TOP: Trigonometric Ratios

823 ANS: 1

$$\sin x = \frac{\text{opposite}}{\text{hypotenuse}} = \frac{28}{53}$$

PTS: 2 REF: 011109ia STA: A.A.42 TOP: Trigonometric Ratios

824 ANS: 2

$$\tan ABC = \frac{\text{opposite}}{\text{adjacent}} = \frac{5}{12}$$

PTS: 2 REF: 081112ia STA: A.A.42 TOP: Trigonometric Ratios

825 ANS: 3

$$\tan PLM = \frac{\text{opposite}}{\text{adjacent}} = \frac{4}{3}$$

PTS: 2 REF: 011226ia STA: A.A.42 TOP: Trigonometric Ratios

826 ANS: 4

If $m\angle C = 90$, then \overline{AB} is the hypotenuse, and the triangle is a 3-4-5 triangle.

PTS: 2 REF: 061224ia STA: A.A.42 TOP: Trigonometric Ratios

827 ANS: 2

$$\cos x = \frac{\text{adjacent}}{\text{hypotenuse}} = \frac{16}{20}$$

PTS: 2 REF: 011307ia STA: A.A.42 TOP: Trigonometric Ratios

828 ANS: 1

$$\cos A = \frac{\text{adjacent}}{\text{hypotenuse}} = \frac{3}{5}$$

PTS: 2 REF: 081329ia STA: A.A.42 TOP: Trigonometric Ratios

829 ANS: 4

PTS: 2

TOP: Trigonometric Ratios

REF: 061417ia

STA: A.A.42

830 ANS: 2

PTS: 2

TOP: Trigonometric Ratios

REF: 081418ia

STA: A.A.42

831 ANS: 4

$$\sin B = \frac{\text{opposite}}{\text{hypotenuse}} = \frac{8}{10}$$

PTS: 2 REF: 011518ia STA: A.A.42 TOP: Trigonometric Ratios

832 ANS: 3

$$\cos 30 = \frac{x}{24}$$

$$x \approx 21$$

PTS: 2 REF: 010912ia STA: A.A.44 TOP: Using Trigonometry to Find a Side

833 ANS:

$$39, 63. \quad \tan 52 = \frac{50}{x} \quad \sin 52 = \frac{50}{x}$$

$$x \approx 39 \quad x \approx 63$$

PTS: 4 REF: 060937ia STA: A.A.44 TOP: Using Trigonometry to Find a Side

834 ANS: 2

$$\tan 32 = \frac{x}{25}$$

$$x \approx 15.6$$

PTS: 2 REF: 080914ia STA: A.A.44 TOP: Using Trigonometry to Find a Side

835 ANS:

$$84, 71 \quad \sin 50 = \frac{x}{110} \quad \cos 50 = \frac{y}{110}$$

$$x \approx 84 \quad y \approx 71$$

PTS: 4 REF: 081039ia STA: A.A.44 TOP: Using Trigonometry to Find a Side

836 ANS:

$$2.1. \cos 65 = \frac{x}{5}$$

$$x \approx 2.1$$

PTS: 2 REF: 011133ia STA: A.A.44 TOP: Using Trigonometry to Find a Side

837 ANS: 2

$$\sin 57 = \frac{x}{8}$$

$$x \approx 6.7$$

PTS: 2 REF: 061108ia STA: A.A.44 TOP: Using Trigonometry to Find a Side

838 ANS: 2

$$\cos 38 = \frac{10}{x}$$

$$x = \frac{10}{\cos 38} \approx 12.69$$

PTS: 2 REF: 081126ia STA: A.A.44 TOP: Using Trigonometry to Find a Side

839 ANS:

$$\tan 48 = \frac{9}{x} \quad \sin 48 = \frac{9}{y}$$

$$x \approx 8 \quad y \approx 12$$

PTS: 4 REF: 011338ia STA: A.A.44 TOP: Using Trigonometry to Find a Side

840 ANS:

$$\tan 38 = \frac{opp}{80}$$

$$opp = 80 \tan 38 \approx 62.5$$

PTS: 3 REF: 011436ia STA: A.A.44 TOP: Using Trigonometry to Find a Side

841 ANS:

$$\tan 26 = \frac{215}{x}$$

$$x = \frac{215}{\tan 26}$$

$$x \approx 441$$

PTS: 3 REF: 081434ia STA: A.A.44 TOP: Using Trigonometry to Find a Side

842 ANS:

$$\cos 72 = \frac{x}{12}$$

$$x \approx 3.7$$

PTS: 2 REF: 011531ia STA: A.A.44 TOP: Using Trigonometry to Find a Side

843 ANS: 2

$$\tan 40 = \frac{x}{72}$$

$$x \approx 60$$

PTS: 2

REF: 061516ia

STA: A.A.44

TOP: Using Trigonometry to Find a Side

844 ANS: 2

$$\sin A = \frac{8}{12}$$

$$A \approx 42$$

PTS: 2

REF: 060816ia

STA: A.A.43

TOP: Using Trigonometry to Find an Angle

845 ANS: 1

PTS: 2

REF: 080824ia

STA: A.A.43

TOP: Using Trigonometry to Find an Angle

846 ANS: 3

$$\sin A = \frac{10}{16} \quad B = 180 - (90 + 38.7) = 51.3. \quad \text{A } 90^\circ \text{ angle is not acute.}$$

$$A \approx 38.7$$

PTS: 2

REF: 080829ia

STA: A.A.43

TOP: Using Trigonometry to Find an Angle

847 ANS:

$$53. \sin A = \frac{16}{20}$$

$$A \approx 53$$

PTS: 2

REF: 011032ia

STA: A.A.43

TOP: Using Trigonometry to Find an Angle

848 ANS:

$$\sin x = \frac{30}{50}$$

$$x = \sin^{-1} \frac{3}{5}$$

$$x \approx 37$$

PTS: 2

REF: 061033ia

STA: A.A.43

TOP: Using Trigonometry to Find an Angle

849 ANS: 1

PTS: 2

REF: 061114ia

STA: A.A.43

TOP: Using Trigonometry to Find an Angle

850 ANS:

$$41.8. \sin x = \frac{8}{12}$$

$$A \approx 41.8$$

PTS: 3

REF: 081135ia

STA: A.A.43

TOP: Using Trigonometry to Find an Angle

851 ANS:

$$78. \cos x = \frac{6}{28}$$

$$x \approx 78$$

PTS: 3 REF: 061235ia STA: A.A.43 TOP: Using Trigonometry to Find an Angle

852 ANS:

$$54, 23. \cos A = \frac{17}{29}. \sqrt{29^2 - 17^2} \approx 23$$

$$x \approx 54$$

PTS: 4 REF: 081238ia STA: A.A.43 TOP: Using Trigonometry to Find an Angle

853 ANS: 4

$$\sin D = \frac{\text{opposite}}{\text{hypotenuse}} = \frac{12}{13}$$

PTS: 2 REF: 061325ia STA: A.A.43 TOP: Using Trigonometry to Find an Angle

854 ANS:

$$\tan x = \frac{350}{1000}$$

$$x \approx 19$$

PTS: 3 REF: 061335ia STA: A.A.43 TOP: Using Trigonometry to Find an Angle

855 ANS: 1

$$\tan x = \frac{5}{9.5}$$

$$x \approx 27.8$$

PTS: 2 REF: 011525ia STA: A.A.43 TOP: Using Trigonometry to Find an Angle

856 ANS: 2

$$\cos E = \frac{6}{11}$$

$$E \approx 57$$

PTS: 2 REF: 061523ia STA: A.A.43 TOP: Using Trigonometry to Find an Angle

857 ANS:

33.4. Serena needs 24 (9 + 6 + 9) feet of fencing to surround the rectangular portion of the garden. The length of the fencing needed for the semicircular portion of the garden is $\frac{1}{2} \pi d = 3\pi \approx 9.4$ feet.

PTS: 2 REF: fall0733ia STA: A.G.1 TOP: Compositions of Polygons and Circles

KEY: perimeter

858 ANS:

$$36 - 9\pi. \quad 15.6. \quad \text{Area of square} - \text{area of 4 quarter circles. } (3 + 3)^2 - 3^2\pi = 36 - 9\pi$$

PTS: 2 REF: 060832ia STA: A.G.1 TOP: Compositions of Polygons and Circles
KEY: area

859 ANS: 2 PTS: 2 REF: 080815ia STA: A.G.1
TOP: Compositions of Polygons and Circles KEY: area

860 ANS:

$$50. \quad 12 + 10 + 12 + \frac{1}{2}(10\pi) \approx 50$$

PTS: 2 REF: 010931ia STA: A.G.1 TOP: Compositions of Polygons and Circles
KEY: perimeter

861 ANS:

56. If the circumference of circle O is 16π inches, the diameter, \overline{AD} , is 16 inches and the length of \overline{BC} is 12 inches $\frac{3}{4} \times 16$. The area of trapezoid $ABCD$ is $\frac{1}{2} \times 4(12 + 16) = 56$.

PTS: 3 REF: 060934ia STA: A.G.1 TOP: Compositions of Polygons and Circles
KEY: area

862 ANS: 1 PTS: 2 REF: 080924ia STA: A.G.1
TOP: Compositions of Polygons and Circles KEY: perimeter

863 ANS: 2

$$A = lw + \frac{\pi r^2}{2} = 6 \cdot 5 + \frac{\pi \cdot 3^2}{2} \approx 44.1$$

PTS: 2 REF: 061029ia STA: A.G.1 TOP: Compositions of Polygons and Circles
KEY: area

864 ANS: 2

shaded = whole - unshaded

= rectangle-triangle

$$= lw - \frac{1}{2}bh$$

$$= 15 \times 6 - \frac{1}{2} \times 15 \times 4.6$$

$$= 90 - 34.5$$

$$= 55.5$$

PTS: 2 REF: 081019ia STA: A.G.1 TOP: Compositions of Polygons and Circles
KEY: area

865 ANS: 2

$$A = lw + lw + \frac{\pi r^2}{4} = 5 \cdot 3 + 5 \cdot 3 + \frac{\pi \cdot 3^2}{4} \approx 37$$

PTS: 2 REF: 011123ia STA: A.G.1 TOP: Compositions of Polygons and Circles
KEY: area

866 ANS: 1

$$7 + 8 + 7 + \frac{12\pi}{2} = 22 + 6\pi$$

PTS: 2 REF: 081128ia STA: A.G.1 TOP: Compositions of Polygons and Circles
KEY: perimeter

867 ANS: 1

If the area of the square is 36, a side is 6, the diameter of the circle is 6, and its radius is 3. $A = \pi r^2 = 3^2 \pi = 9\pi$

PTS: 2 REF: 011217ia STA: A.G.1 TOP: Compositions of Polygons and Circles
KEY: area

868 ANS: 1

$$4 + 6 + 10 + \frac{6\pi}{2} = 20 + 3\pi$$

PTS: 2 REF: 081228ia STA: A.G.1 TOP: Compositions of Polygons and Circles
KEY: perimeter

869 ANS: 3 PTS: 2 REF: 011315ia STA: A.G.1
TOP: Compositions of Polygons and Circles KEY: area

870 ANS:

Area of rectangle minus area of semicircle: $(5 + 6 + 5) \times 5 - \frac{\pi \times 3^2}{2} \approx 65.86$

PTS: 4 REF: 061339ia STA: A.G.1 TOP: Compositions of Polygons and Circles
KEY: area

871 ANS: 1

$$4(5 + 5) + 10\pi = 40 + 10\pi$$

PTS: 2 REF: 081326ia STA: A.G.1 TOP: Compositions of Polygons and Circles
KEY: perimeter

872 ANS: 2

$$6^2 - \frac{(3)^2 \pi}{2}$$

PTS: 2 REF: 011407ia STA: A.G.1 TOP: Compositions of Polygons and Circles
KEY: area

873 ANS:

$$(2x)^2 + \pi x^2 = 4x^2 + \pi x^2$$

PTS: 2 REF: 061431ia STA: A.G.1 TOP: Compositions of Polygons and Circles
KEY: area

874 ANS:

$$30 + 15 + 30 + \frac{15\pi}{2} \approx 98.6$$

PTS: 2

REF: 061433ia

STA: A.G.1

TOP: Compositions of Polygons and Circles

KEY: perimeter

875 ANS:

$$16 + 2\pi \approx 22.3$$

PTS: 2

REF: 081432ia

STA: A.G.1

TOP: Compositions of Polygons and Circles

KEY: perimeter

876 ANS:

$$(15 \times 36) - (\pi \cdot 4^2) \approx 490 \quad 490 \times 8.95 = 4385.50$$

PTS: 4

REF: 011537ia

STA: A.G.1

TOP: Compositions of Polygons and Circles

KEY: area

877 ANS:

$$7\sqrt{3}$$

PTS: 2

REF: 061532ia

STA: A.G.1

TOP: Compositions of Polygons and Circles

KEY: perimeter

878 ANS: 4

$$V = \pi r^2 h = \pi \cdot 6^2 \cdot 15 \approx 1696.5$$

PTS: 2

REF: fall0712ia

STA: A.G.2

TOP: Volume

879 ANS: 2

$$1.5^3 = 3.375$$

PTS: 2

REF: 060809ia

STA: A.G.2

TOP: Volume

880 ANS:

$$\frac{38}{\pi}, 2, \quad V = \pi r^2 h \quad , \quad \frac{36}{\left(\frac{38}{\pi}\right)} \approx 2.97. \text{ Three cans will not fit. The maximum number is 2.}$$

$$342 = \pi \left(\frac{6}{2}\right)^2 h$$

$$\frac{342}{9\pi} = h$$

$$\frac{38}{\pi} = h$$

PTS: 3

REF: 010936ia

STA: A.G.2

TOP: Volume

881 ANS:

$$5,112. \quad (12 \times 30 \times 16) - (6 \times 12 \times 9) = 5112$$

PTS: 2

REF: 080932ia

STA: A.G.2

TOP: Volume

882 ANS: 3

$$V = \pi r^2 h = \pi \cdot 5^2 \cdot 2.3 \approx 180.6$$

PTS: 2 REF: 081105ia STA: A.G.2 TOP: Volume

883 ANS:

Carol's, by 14.9. $V_M = 5 \times 3.5 \times 7 = 122.5$. $V_C = \pi \times 2.5^2 \times 7 \approx 137.4$. $137.4 - 122.5 = 14.9$

PTS: 4 REF: 061237ia STA: A.G.2 TOP: Volume

884 ANS: 4

$$V = \pi r^2 h$$

$$32\pi = \pi r^2(2)$$

$$16 = r^2$$

$$4 = r$$

PTS: 2 REF: 081224ia STA: A.G.2 TOP: Volume

885 ANS: 3

$$\frac{10^3}{5^3} = \frac{1000}{125} = 8$$

PTS: 2 REF: 011312ia STA: A.G.2 TOP: Volume

886 ANS:

$$V = \pi r^2 h = \pi \cdot 6.5^2 \cdot 24 = 1014\pi$$

PTS: 2 REF: 061332ia STA: A.G.2 TOP: Volume

887 ANS:

$$V = \pi \cdot 2.5^2 \cdot 11 \approx 215.98$$

PTS: 2 REF: 081433ia STA: A.G.2 TOP: Volume

888 ANS: 3

$$V = \pi \cdot 3^2 \cdot 7 = 63\pi$$

PTS: 2 REF: 011505ia STA: A.G.2 TOP: Volume

889 ANS: 2

$$5 \times 4 \times 2 \frac{1}{2} = 50$$

PTS: 2 REF: 061530ia STA: A.G.2 TOP: Volume

890 ANS: 4

$$SA = 2lw + 2hw + 2lh = 2(3)(1.5) + 2(2)(1.5) + 2(3)(2) = 27$$

PTS: 2 REF: 060827ia STA: A.G.2 TOP: Surface Area

891 ANS: 4

$$SA = 2lw + 2hw + 2lh = 2(2)(3) + 2(4)(3) + 2(2)(4) = 52$$

PTS: 2 REF: 011029ia STA: A.G.2 TOP: Surface Area

892 ANS:
 $80, 136$ $V = lwh = 10 \cdot 2 \cdot 4 = 80$ $SA = 2lw + 2hw + 2lh = 2 \cdot 10 \cdot 2 + 2 \cdot 4 \cdot 2 + 2 \cdot 10 \cdot 4 = 136$

PTS: 3 REF: 081035ia STA: A.G.2 TOP: Surface Area

893 ANS:
 $2(x+3)(x-4) + 2(5)(x-4) + 2(x+3)(5)$
 $2(x^2 - 4x + 3x - 12) + 10(x-4) + 10(x+3)$
 $2x^2 - 2x - 24 + 10x - 40 + 10x + 30$
 $2x^2 + 18x - 34$

PTS: 3 REF: 061136ia STA: A.G.2 TOP: Surface Area

894 ANS:
 147.75 $2 \times 5.5 \times 3 + 2 \times 6.75 \times 3 + 2 \times 5.5 \times 6.75 = 147.75$

PTS: 2 REF: 011231ia STA: A.G.2 TOP: Surface Area

895 ANS: 4
 $SA = 2lw + 2hw + 2lh = 2(3)(2.2) + 2(7.5)(2.2) + 2(3)(7.5) = 91.2$

PTS: 2 REF: 081216ia STA: A.G.2 TOP: Surface Area

896 ANS: 2
 $s^3 = 8$. $6 \times (2 \times 2) = 24$
 $s = 2$

PTS: 2 REF: 081325ia STA: A.G.2 TOP: Surface Area

897 ANS: 2
 $SA = 2\pi(2.5)^2 + 2\pi(2.5)(8) \approx 165$

PTS: 2 REF: 061514ia STA: A.G.2 TOP: Surface Area