

JMAP

REGENTS BY DATE

The NY Integrated Algebra Regents Exams
Fall, 2007-January, 2014

www.jmap.org

fall07ia

- 1 For 10 days, Romero kept a record of the number of hours he spent listening to music. The information is shown in the table below.

Day	1	2	3	4	5	6	7	8	9	10
Hours	9	3	2	6	8	6	10	4	5	2

Which scatter plot shows Romero's data graphically?

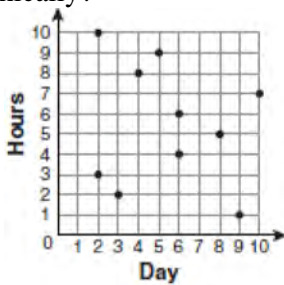

1)

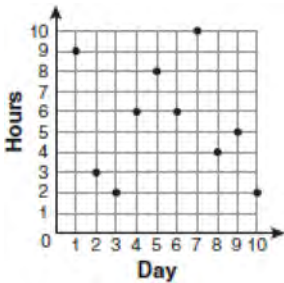

2)

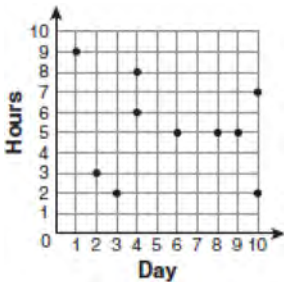

3)

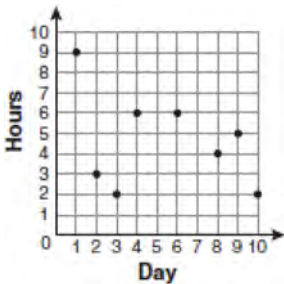

4)

- 2 Throughout history, many people have contributed to the development of mathematics. These mathematicians include Pythagoras, Euclid, Hypatia, Euler, Einstein, Agnesi, Fibonacci, and Pascal. What is the probability that a mathematician's name selected at random from those listed will start with either the letter *E* or the letter *A*?

- 1) $\frac{2}{8}$
- 2) $\frac{3}{8}$
- 3) $\frac{4}{8}$
- 4) $\frac{6}{8}$

- 3 Which expression represents $\frac{(2x^3)(8x^5)}{4x^6}$ in simplest form?

- 1) x^2
- 2) x^9
- 3) $4x^2$
- 4) $4x^9$

- 4 Which interval notation represents the set of all numbers from 2 through 7, inclusive?

- 1) $(2,7]$
- 2) $(2,7)$
- 3) $[2,7)$
- 4) $[2,7]$

- 5 Which property is illustrated by the equation $ax + ay = a(x + y)$?
- 1) associative
 - 2) commutative
 - 3) distributive
 - 4) identity
- 6 The expression $x^2 - 16$ is equivalent to
- 1) $(x + 2)(x - 8)$
 - 2) $(x - 2)(x + 8)$
 - 3) $(x + 4)(x - 4)$
 - 4) $(x + 8)(x - 8)$
- 7 Which situation describes a correlation that is *not* a causal relationship?
- 1) The rooster crows, and the Sun rises.
 - 2) The more miles driven, the more gasoline needed
 - 3) The more powerful the microwave, the faster the food cooks.
 - 4) The faster the pace of a runner, the quicker the runner finishes.
- 8 The equations $5x + 2y = 48$ and $3x + 2y = 32$ represent the money collected from school concert ticket sales during two class periods. If x represents the cost for each adult ticket and y represents the cost for each student ticket, what is the cost for each adult ticket?
- 1) \$20
 - 2) \$10
 - 3) \$8
 - 4) \$4

- 9 The data set 5, 6, 7, 8, 9, 9, 9, 10, 12, 14, 17, 17, 18, 19, 19 represents the number of hours spent on the Internet in a week by students in a mathematics class. Which box-and-whisker plot represents the data?

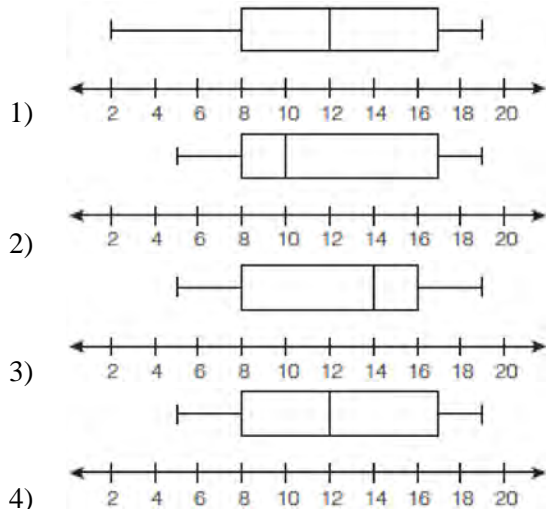

- 10 Given:
 Set $A = \{(-2, -1), (-1, 0), (1, 8)\}$
 Set $B = \{(-3, -4), (-2, -1), (-1, 2), (1, 8)\}$.
 What is the intersection of sets A and B ?
- 1) $\{(1, 8)\}$
 - 2) $\{(-2, -1)\}$
 - 3) $\{(-2, -1), (1, 8)\}$
 - 4) $\{(-3, -4), (-2, -1), (-1, 2), (-1, 0), (1, 8)\}$

- 11 Tanya runs diagonally across a rectangular field that has a length of 40 yards and a width of 30 yards, as shown in the diagram below.

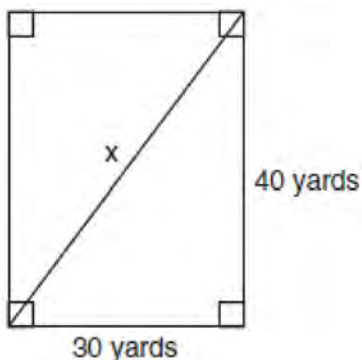

What is the length of the diagonal, in yards, that Tanya runs?

- 1) 50
- 2) 60
- 3) 70
- 4) 80

- 12 A cylindrical container has a diameter of 12 inches and a height of 15 inches, as illustrated in the diagram below.

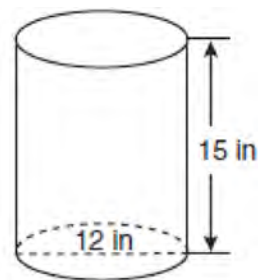

(Not drawn to scale)

What is the volume of this container to the *nearest tenth* of a cubic inch?

- 1) 6,785.8
- 2) 4,241.2
- 3) 2,160.0
- 4) 1,696.5

- 13 What is an equation for the line that passes through the coordinates (2,0) and (0,3)?

- 1) $y = -\frac{3}{2}x + 3$
- 2) $y = -\frac{3}{2}x - 3$
- 3) $y = -\frac{2}{3}x + 2$
- 4) $y = -\frac{2}{3}x - 2$

- 14 Which situation should be analyzed using bivariate data?
- 1) Ms. Saleem keeps a list of the amount of time her daughter spends on her social studies homework.
 - 2) Mr. Benjamin tries to see if his students' shoe sizes are directly related to their heights.
 - 3) Mr. DeStefan records his customers' best video game scores during the summer.
 - 4) Mr. Chan keeps track of his daughter's algebra grades for the quarter.

- 15 An electronics store sells DVD players and cordless telephones. The store makes a \$75 profit on the sale of each DVD player (d) and a \$30 profit on the sale of each cordless telephone (c). The store wants to make a profit of at least \$255.00 from its sales of DVD players and cordless phones. Which inequality describes this situation?
- 1) $75d + 30c < 255$
 - 2) $75d + 30c \leq 255$
 - 3) $75d + 30c > 255$
 - 4) $75d + 30c \geq 255$

- 16 What is the slope of the line containing the points (3,4) and (-6,10)?
- 1) $\frac{1}{2}$
 - 2) 2
 - 3) $-\frac{2}{3}$
 - 4) $-\frac{3}{2}$

- 17 Which type of graph is shown in the diagram below?

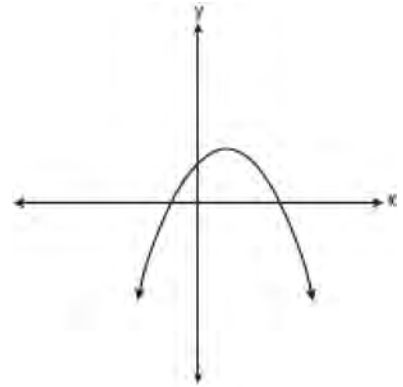

- 1) absolute value
 - 2) exponential
 - 3) linear
 - 4) quadratic
- 18 The expression $\frac{9x^4 - 27x^6}{3x^3}$ is equivalent to
- 1) $3x(1 - 3x)$
 - 2) $3x(1 - 3x^2)$
 - 3) $3x(1 - 9x^5)$
 - 4) $9x^3(1 - x)$
- 19 Daniel's Print Shop purchased a new printer for \$35,000. Each year it depreciates (loses value) at a rate of 5%. What will its approximate value be at the end of the fourth year?
- 1) \$33,250.00
 - 2) \$30,008.13
 - 3) \$28,507.72
 - 4) \$27,082.33

20 Which inequality is represented by the graph below?

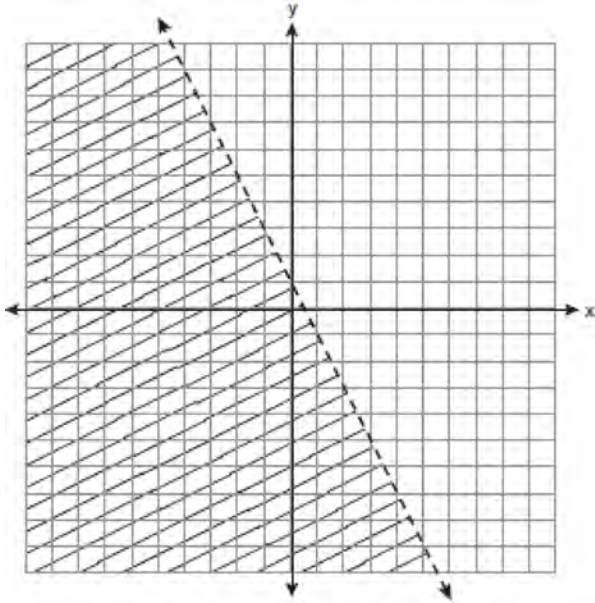

- 1) $y < 2x + 1$
- 2) $y < -2x + 1$
- 3) $y < \frac{1}{2}x + 1$
- 4) $y < -\frac{1}{2}x + 1$

21 In triangle MCT , the measure of $\angle T = 90^\circ$, $MC = 85$ cm, $CT = 84$ cm, and $TM = 13$ cm. Which ratio represents the sine of $\angle C$?

- 1) $\frac{13}{85}$
- 2) $\frac{84}{85}$
- 3) $\frac{13}{84}$
- 4) $\frac{84}{13}$

22 The diagram below shows the graph of $y = |x - 3|$.

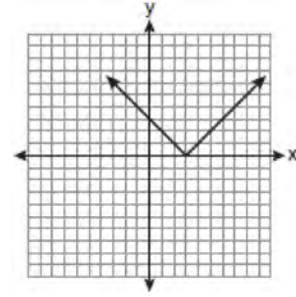

Which diagram shows the graph of $y = -|x - 3|$?

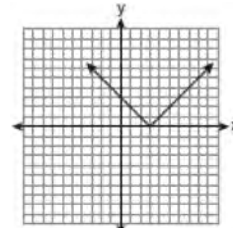

1)

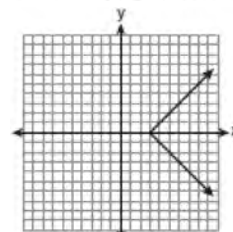

2)

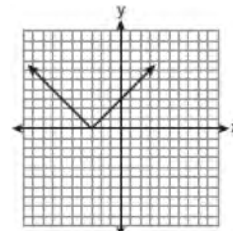

3)

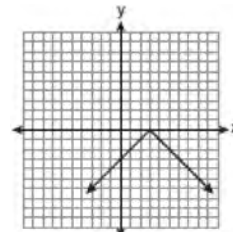

4)

23 The groundskeeper is replacing the turf on a football field. His measurements of the field are 130 yards by 60 yards. The actual measurements are 120 yards by 54 yards. Which expression represents the relative error in the measurement?

- 1) $\frac{(130)(60) - (120)(54)}{(120)(54)}$
- 2) $\frac{(120)(54)}{(130)(60) - (120)(54)}$
- 3) $\frac{(130)(60) - (120)(54)}{(130)(60)}$
- 4) $\frac{(130)(60)}{(130)(60) - (120)(54)}$

24 Which value of x is in the solution set of the inequality $-2x + 5 > 17$?

- 1) -8
- 2) -6
- 3) -4
- 4) 12

25 What is the quotient of 8.05×10^6 and 3.5×10^2 ?

- 1) 2.3×10^3
- 2) 2.3×10^4
- 3) 2.3×10^8
- 4) 2.3×10^{12}

26 The length of a rectangular window is 5 feet more than its width, w . The area of the window is 36 square feet. Which equation could be used to find the dimensions of the window?

- 1) $w^2 + 5w + 36 = 0$
- 2) $w^2 - 5w - 36 = 0$
- 3) $w^2 - 5w + 36 = 0$
- 4) $w^2 + 5w - 36 = 0$

27 What is the sum of $\frac{d}{2}$ and $\frac{2d}{3}$ expressed in simplest form?

- 1) $\frac{3d}{5}$
- 2) $\frac{3d}{6}$
- 3) $\frac{7d}{5}$
- 4) $\frac{7d}{6}$

28 For which value of x is $\frac{x-3}{x^2-4}$ undefined?

- 1) -2
- 2) 0
- 3) 3
- 4) 4

29 Which verbal expression represents $2(n-6)$?

- 1) two times n minus six
- 2) two times six minus n
- 3) two times the quantity n less than six
- 4) two times the quantity six less than n

30 Which graph represents a function?

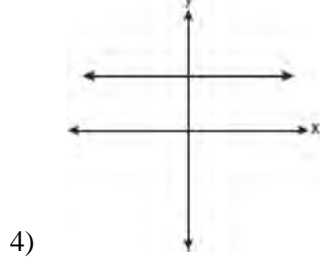
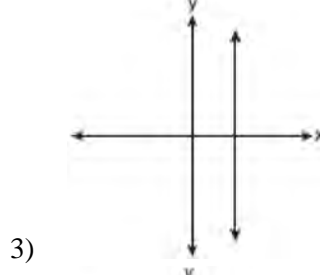
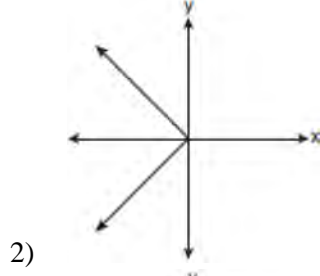
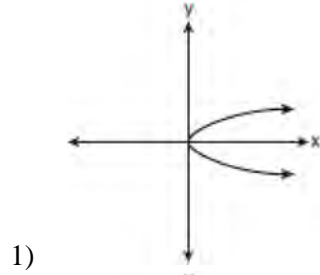

31 Express $5\sqrt{72}$ in simplest radical form.

32 Solve for g : $3 + 2g = 5g - 9$

33 Serena's garden is a rectangle joined with a semicircle, as shown in the diagram below. Line segment AB is the diameter of semicircle P . Serena wants to put a fence around her garden.

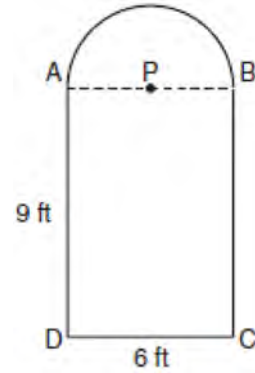

Calculate the length of fence Serena needs to the nearest tenth of a foot.

34 Hannah took a trip to visit her cousin. She drove 120 miles to reach her cousin's house and the same distance back home. It took her 1.2 hours to get halfway to her cousin's house. What was her average speed, in miles per hour, for the first 1.2 hours of the trip? Hannah's average speed for the remainder of the trip to her cousin's house was 40 miles per hour. How long, in hours, did it take her to drive the remaining distance? Traveling home along the same route, Hannah drove at an average rate of 55 miles per hour. After 2 hours her car broke down. How many miles was she from home?

35 A prom ticket at Smith High School is \$120. Tom is going to save money for the ticket by walking his neighbor's dog for \$15 per week. If Tom already has saved \$22, what is the minimum number of weeks Tom must walk the dog to earn enough to pay for the prom ticket?

36 Mr. Laub has three children: two girls (Sue and Karen) and one boy (David). After each meal, one child is chosen at random to wash dishes. If the same child can be chosen for both lunch and dinner, construct a tree diagram or list a sample space of all the possible outcomes of who will wash dishes after lunch and dinner on Saturday. Determine the probability that one boy and one girl will wash dishes after lunch and dinner on Saturday.

37 The values of 11 houses on Washington St. are shown in the table below.

Value per House	Number of Houses
\$100,000	1
\$175,000	5
\$200,000	4
\$700,000	1

Find the mean value of these houses in dollars.
 Find the median value of these houses in dollars.
 State which measure of central tendency, the mean or the median, *best* represents the values of these 11 houses. Justify your answer.

38 Solve the following systems of equations graphically, on the set of axes below, and state the coordinates of the point(s) in the solution set.

$$y = x^2 - 6x + 5$$

$$2x + y = 5$$

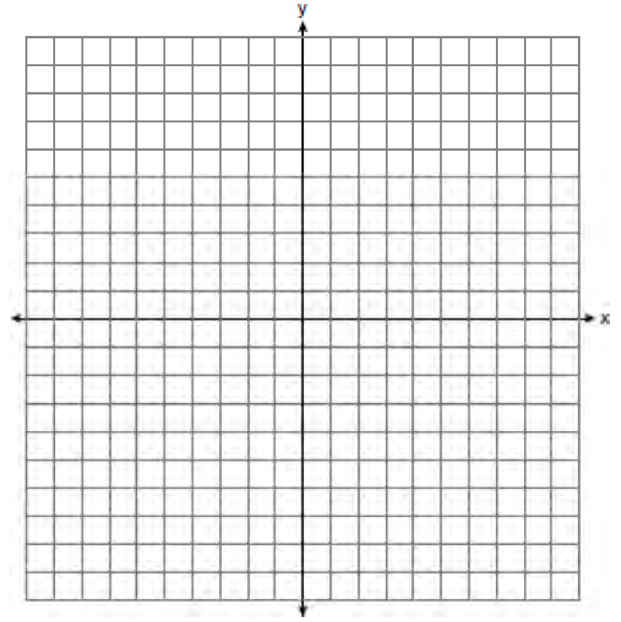

39 Solve for x : $\frac{x+1}{x} = \frac{-7}{x-12}$

0608ia

1 Which graph represents a linear function?

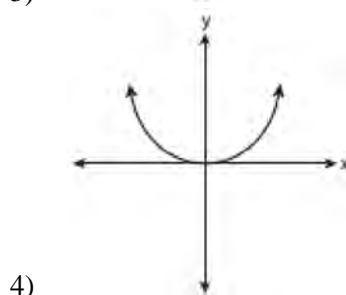
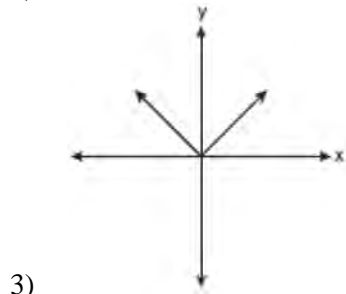
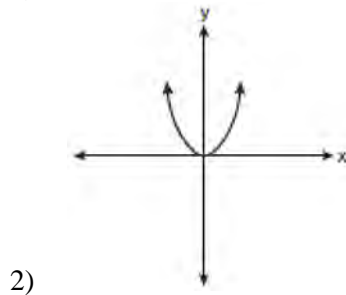
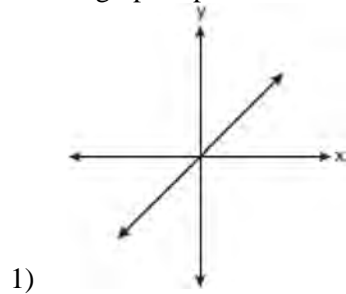

2 A spinner is divided into eight equal regions as shown in the diagram below.

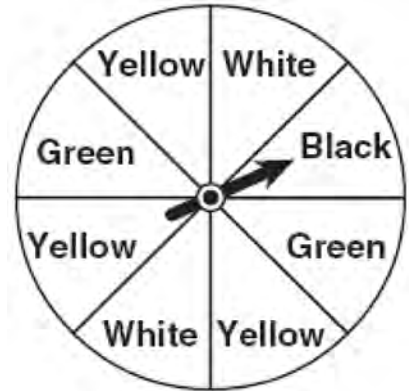

Which event is most likely to occur in one spin?

- 1) The arrow will land in a green or white area.
- 2) The arrow will land in a green or black area.
- 3) The arrow will land in a yellow or black area.
- 4) The arrow will land in a yellow or green area.

3 A school wants to add a coed soccer program. To determine student interest in the program, a survey will be taken. In order to get an unbiased sample, which group should the school survey?

- 1) every third student entering the building
- 2) every member of the varsity football team
- 3) every member in Ms. Zimmer's drama classes
- 4) every student having a second-period French class

4 Factored, the expression $16x^2 - 25y^2$ is equivalent to

- 1) $(4x - 5y)(4x + 5y)$
- 2) $(4x - 5y)(4x - 5y)$
- 3) $(8x - 5y)(8x + 5y)$
- 4) $(8x - 5y)(8x - 5y)$

- 5 There is a negative correlation between the number of hours a student watches television and his or her social studies test score. Which scatter plot below displays this correlation?

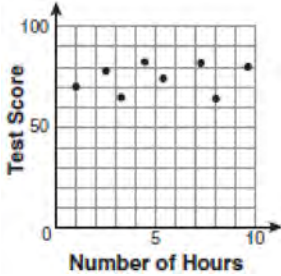

1)

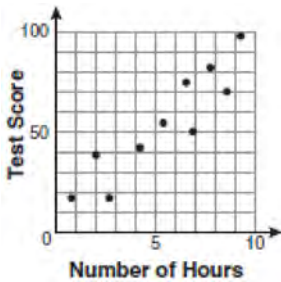

2)

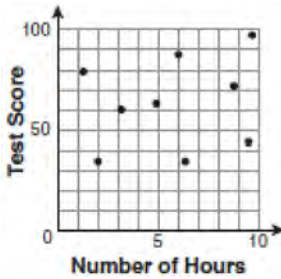

3)

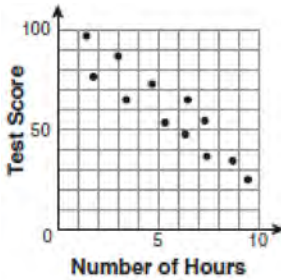

4)

- 6 Jack bought 3 slices of cheese pizza and 4 slices of mushroom pizza for a total cost of \$12.50. Grace bought 3 slices of cheese pizza and 2 slices of mushroom pizza for a total cost of \$8.50. What is the cost of one slice of mushroom pizza?

- 1) \$1.50
- 2) \$2.00
- 3) \$3.00
- 4) \$3.50

- 7 What is the product of $-3x^2y$ and $(5xy^2 + xy)$?

- 1) $-15x^3y^3 - 3x^3y^2$
- 2) $-15x^3y^3 - 3x^3y$
- 3) $-15x^2y^2 - 3x^2y$
- 4) $-15x^3y^3 + xy$

- 8 The bowling team at Lincoln High School must choose a president, vice president, and secretary. If the team has 10 members, which expression could be used to determine the number of ways the officers could be chosen?

- 1) ${}_3P_{10}$
- 2) ${}_7P_3$
- 3) ${}_{10}P_3$
- 4) ${}_{10}P_7$

- 9 Lenny made a cube in technology class. Each edge measured 1.5 cm. What is the volume of the cube in cubic centimeters?

- 1) 2.25
- 2) 3.375
- 3) 9.0
- 4) 13.5

- 10 Which ordered pair is a solution to the system of equations $y = x$ and $y = x^2 - 2$?
- 1) $(-2, -2)$
 - 2) $(-1, 1)$
 - 3) $(0, 0)$
 - 4) $(2, 2)$

- 11 What are the vertex and the axis of symmetry of the parabola shown in the diagram below?

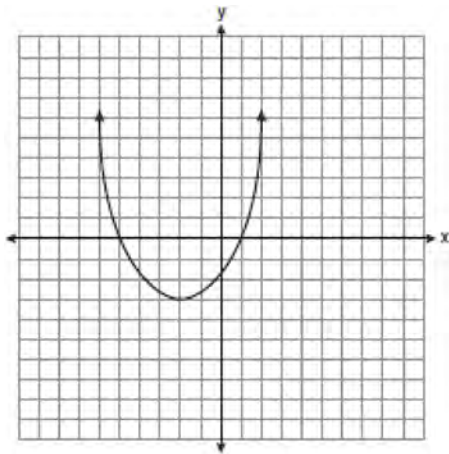

- 1) The vertex is $(-2, -3)$, and the axis of symmetry is $x = -2$.
- 2) The vertex is $(-2, -3)$, and the axis of symmetry is $y = -2$.
- 3) The vertex is $(-3, -2)$, and the axis of symmetry is $y = -2$.
- 4) The vertex is $(-3, -2)$, and the axis of symmetry is $x = -2$.

- 12 Pam is playing with red and black marbles. The number of red marbles she has is three more than twice the number of black marbles she has. She has 42 marbles in all. How many red marbles does Pam have?
- 1) 13
 - 2) 15
 - 3) 29
 - 4) 33

- 13 What is half of 2^6 ?
- 1) 1^3
 - 2) 1^6
 - 3) 2^3
 - 4) 2^5

- 14 Which equation represents a line that is parallel to the line $y = -4x + 5$?
- 1) $y = -4x + 3$
 - 2) $y = -\frac{1}{4}x + 5$
 - 3) $y = \frac{1}{4}x + 3$
 - 4) $y = 4x + 5$

- 15 What is the product of $\frac{x^2 - 1}{x + 1}$ and $\frac{x + 3}{3x - 3}$ expressed in simplest form?
- 1) x
 - 2) $\frac{x}{3}$
 - 3) $x + 3$
 - 4) $\frac{x + 3}{3}$

- 16 The center pole of a tent is 8 feet long, and a side of the tent is 12 feet long as shown in the diagram below.

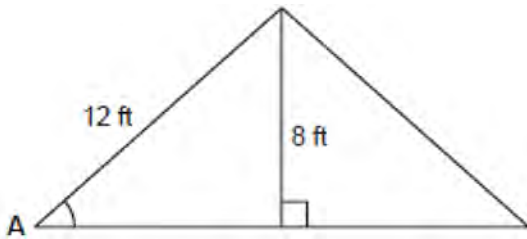

If a right angle is formed where the center pole meets the ground, what is the measure of angle *A* to the *nearest degree*?

- 1) 34
 - 2) 42
 - 3) 48
 - 4) 56
- 17 Which value of x makes the expression $\frac{x+4}{x-3}$ undefined?
- 1) -4
 - 2) -3
 - 3) 3
 - 4) 0
- 18 Consider the set of integers greater than -2 and less than 6 . A subset of this set is the positive factors of 5 . What is the complement of this subset?
- 1) $\{0, 2, 3, 4\}$
 - 2) $\{-1, 0, 2, 3, 4\}$
 - 3) $\{-2, -1, 0, 2, 3, 4, 6\}$
 - 4) $\{-2, -1, 0, 1, 2, 3, 4, 5, 6\}$

- 19 Which data set describes a situation that could be classified as qualitative?
- 1) the elevations of the five highest mountains in the world
 - 2) the ages of presidents at the time of their inauguration
 - 3) the opinions of students regarding school lunches
 - 4) the shoe sizes of players on the basketball team
- 20 What is the slope of the line that passes through the points $(-6, 1)$ and $(4, -4)$?
- 1) -2
 - 2) 2
 - 3) $-\frac{1}{2}$
 - 4) $\frac{1}{2}$
- 21 Students in a ninth grade class measured their heights, h , in centimeters. The height of the shortest student was 155 cm, and the height of the tallest student was 190 cm. Which inequality represents the range of heights?
- 1) $155 < h < 190$
 - 2) $155 \leq h \leq 190$
 - 3) $h \geq 155$ or $h \leq 190$
 - 4) $h > 155$ or $h < 190$

- 22 The table below shows a cumulative frequency distribution of runners' ages.

Cumulative Frequency Distribution of Runners' Ages

Age Group	Total
20-29	8
20-39	18
20-49	25
20-59	31
20-69	35

According to the table, how many runners are in their forties?

- 1) 25
 - 2) 10
 - 3) 7
 - 4) 6
- 23 Mr. Turner bought x boxes of pencils. Each box holds 25 pencils. He left 3 boxes of pencils at home and took the rest to school. Which expression represents the total number of pencils he took to school?
- 1) $22x$
 - 2) $25x - 3$
 - 3) $25 - 3x$
 - 4) $25x - 75$

- 24 Which expression represents $\frac{2x^2 - 12x}{x - 6}$ in simplest form?
- 1) 0
 - 2) $2x$
 - 3) $4x$
 - 4) $2x + 2$

- 25 Don placed a ladder against the side of his house as shown in the diagram below.

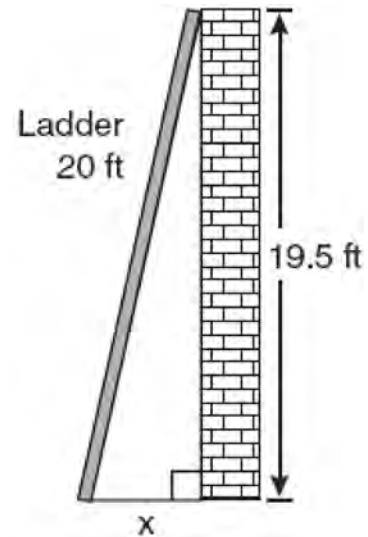

Which equation could be used to find the distance, x , from the foot of the ladder to the base of the house?

- 1) $x = 20 - 19.5$
 - 2) $x = 20^2 - 19.5^2$
 - 3) $x = \sqrt{20^2 - 19.5^2}$
 - 4) $x = \sqrt{20^2 + 19.5^2}$
- 26 Which value of x is a solution of $\frac{5}{x} = \frac{x+13}{6}$?
- 1) -2
 - 2) -3
 - 3) -10
 - 4) -15

27 Mrs. Ayer is painting the outside of her son's toy box, including the top and bottom. The toy box measures 3 feet long, 1.5 feet wide, and 2 feet high. What is the total surface area she will paint?

- 1) 9.0 ft^2
- 2) 13.5 ft^2
- 3) 22.5 ft^2
- 4) 27.0 ft^2

28 What is $\frac{\sqrt{32}}{4}$ expressed in simplest radical form?

- 1) $\sqrt{2}$
- 2) $4\sqrt{2}$
- 3) $\sqrt{8}$
- 4) $\frac{\sqrt{8}}{2}$

29 Consider the graph of the equation $y = ax^2 + bx + c$, when $a \neq 0$. If a is multiplied by 3, what is true of the graph of the resulting parabola?

- 1) The vertex is 3 units above the vertex of the original parabola.
- 2) The new parabola is 3 units to the right of the original parabola.
- 3) The new parabola is wider than the original parabola.
- 4) The new parabola is narrower than the original parabola.

30 Kathy plans to purchase a car that depreciates (loses value) at a rate of 14% per year. The initial cost of the car is \$21,000. Which equation represents the value, v , of the car after 3 years?

- 1) $v = 21,000(0.14)^3$
- 2) $v = 21,000(0.86)^3$
- 3) $v = 21,000(1.14)^3$
- 4) $v = 21,000(0.86)(3)$

31 Tom drove 290 miles from his college to home and used 23.2 gallons of gasoline. His sister, Ann, drove 225 miles from her college to home and used 15 gallons of gasoline. Whose vehicle had better gas mileage? Justify your answer.

32 A designer created the logo shown below. The logo consists of a square and four quarter-circles of equal size.

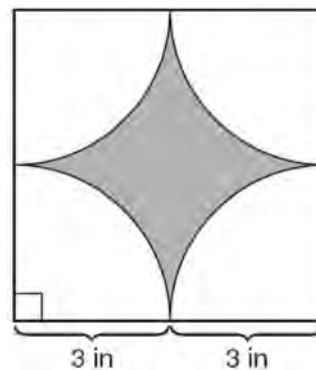

Express, in terms of π , the exact area, in square inches, of the shaded region.

- 33 Maureen tracks the range of outdoor temperatures over three days. She records the following information.

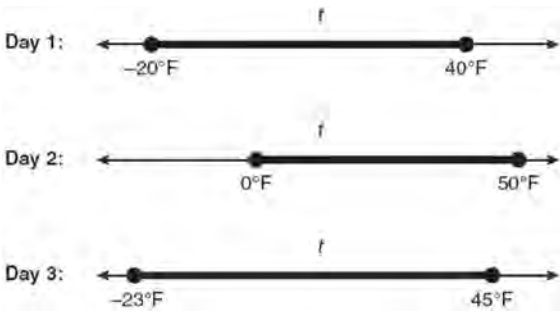

Express the intersection of the three sets as an inequality in terms of temperature, t .

- 34 Peter begins his kindergarten year able to spell 10 words. He is going to learn to spell 2 new words every day. Write an inequality that can be used to determine how many days, d , it takes Peter to be able to spell *at least* 75 words. Use this inequality to determine the minimum number of whole days it will take for him to be able to spell *at least* 75 words.
- 35 The Hudson Record Store is having a going-out-of-business sale. CDs normally sell for \$18.00. During the first week of the sale, all CDs will sell for \$15.00. Written as a fraction, what is the rate of discount? What is this rate expressed as a percent? Round your answer to the *nearest hundredth of a percent*. During the second week of the sale, the same CDs will be on sale for 25% off the *original* price. What is the price of a CD during the second week of the sale?

- 36 Graph the equation $y = x^2 - 2x - 3$ on the accompanying set of axes. Using the graph, determine the roots of the equation $x^2 - 2x - 3 = 0$.

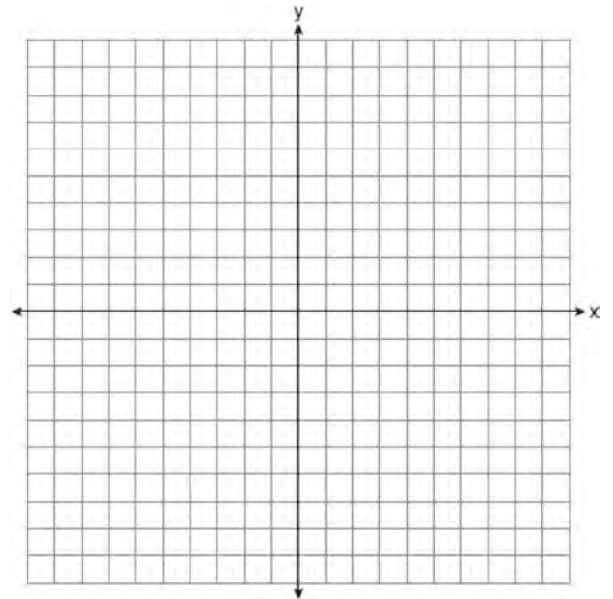

- 37 A contractor needs 54 square feet of brick to construct a rectangular walkway. The length of the walkway is 15 feet more than the width. Write an equation that could be used to determine the dimensions of the walkway. Solve this equation to find the length and width, in feet, of the walkway.

- 38 Sophie measured a piece of paper to be 21.7 cm by 28.5 cm. The piece of paper is actually 21.6 cm by 28.4 cm. Determine the number of square centimeters in the area of the piece of paper using Sophie's measurements. Determine the number of square centimeters in the actual area of the piece of paper. Determine the relative error in calculating the area. Express your answer as a decimal to the *nearest thousandth*. Sophie does not think there is a significant amount of error. Do you agree or disagree? Justify your answer.
- 39 The prices of seven race cars sold last week are listed in the table below.

Price per Race Car	Number of Race Cars
\$126,000	1
\$140,000	2
\$180,000	1
\$400,000	2
\$819,000	1

What is the mean value of these race cars, in dollars? What is the median value of these race cars, in dollars? State which of these measures of central tendency best represents the value of the seven race cars. Justify your answer.

0808ia

- 1 Which value of p is the solution of $5p - 1 = 2p + 20$?
- 1) $\frac{19}{7}$
 - 2) $\frac{19}{3}$
 - 3) 3
 - 4) 7
- 2 The statement $2 + 0 = 2$ is an example of the use of which property of real numbers?
- 1) associative
 - 2) additive identity
 - 3) additive inverse
 - 4) distributive
- 3 Mrs. Smith wrote "Eight less than three times a number is greater than fifteen" on the board. If x represents the number, which inequality is a correct translation of this statement?
- 1) $3x - 8 > 15$
 - 2) $3x - 8 < 15$
 - 3) $8 - 3x > 15$
 - 4) $8 - 3x < 15$
- 4 Which statement is true about the data set 3, 4, 5, 6, 7, 7, 10?
- 1) mean = mode
 - 2) mean > mode
 - 3) mean = median
 - 4) mean < median
- 5 Which value of x is in the solution set of the inequality $-4x + 2 > 10$?
- 1) -2
 - 2) 2
 - 3) 3
 - 4) -4
- 6 Factored completely, the expression $2x^2 + 10x - 12$ is equivalent to
- 1) $2(x - 6)(x + 1)$
 - 2) $2(x + 6)(x - 1)$
 - 3) $2(x + 2)(x + 3)$
 - 4) $2(x - 2)(x - 3)$

- 7 The gas tank in a car holds a total of 16 gallons of gas. The car travels 75 miles on 4 gallons of gas. If the gas tank is full at the beginning of a trip, which graph represents the rate of change in the amount of gas in the tank?

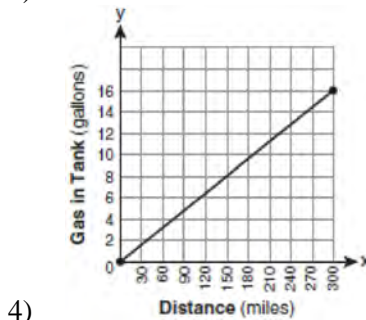
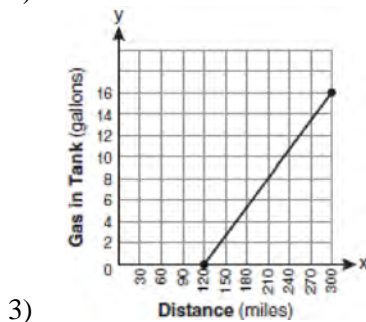
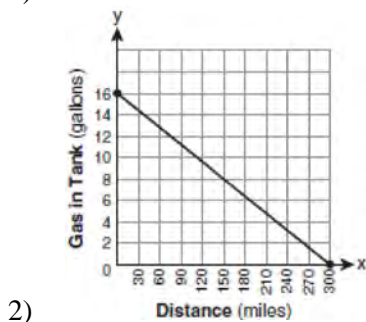
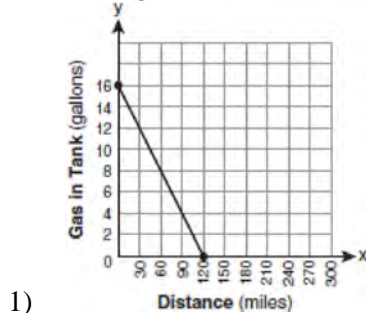

- 8 If $3ax + b = c$, then x equals

- 1) $c - b + 3a$
- 2) $c + b - 3a$
- 3) $\frac{c - b}{3a}$
- 4) $\frac{b - c}{3a}$

- 9 The length of the hypotenuse of a right triangle is 34 inches and the length of one of its legs is 16 inches. What is the length, in inches, of the other leg of this right triangle?

- 1) 16
- 2) 18
- 3) 25
- 4) 30

- 10 Which equation represents a line parallel to the x -axis?

- 1) $x = 5$
- 2) $y = 10$
- 3) $x = \frac{1}{3}y$
- 4) $y = 5x + 17$

- 11 Sam and Odel have been selling frozen pizzas for a class fundraiser. Sam has sold half as many pizzas as Odel. Together they have sold a total of 126 pizzas. How many pizzas did Sam sell?

- 1) 21
- 2) 42
- 3) 63
- 4) 84

- 12 Which ordered pair is in the solution set of the system of equations $y = -x + 1$ and $y = x^2 + 5x + 6$?
- 1) $(-5, -1)$
 - 2) $(-5, 6)$
 - 3) $(5, -4)$
 - 4) $(5, 2)$

- 13 A swim team member performs a dive from a 14-foot-high springboard. The parabola below shows the path of her dive.

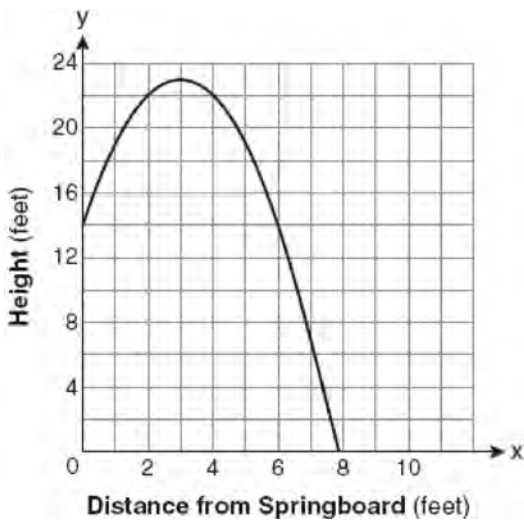

Which equation represents the axis of symmetry?

- 1) $x = 3$
- 2) $y = 3$
- 3) $x = 23$
- 4) $y = 23$

- 14 Nicole's aerobics class exercises to fast-paced music. If the rate of the music is 120 beats per minute, how many beats would there be in a class that is 0.75 hour long?
- 1) 90
 - 2) 160
 - 3) 5,400
 - 4) 7,200

- 15 Luis is going to paint a basketball court on his driveway, as shown in the diagram below. This basketball court consists of a rectangle and a semicircle.

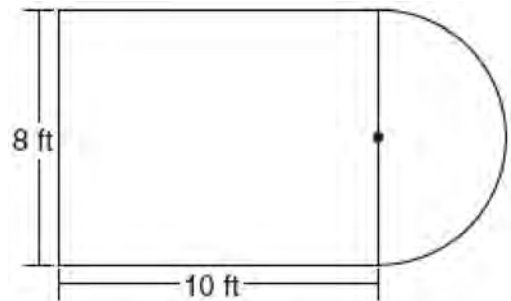

Which expression represents the area of this basketball court, in square feet?

- 1) 80
- 2) $80 + 8\pi$
- 3) $80 + 16\pi$
- 4) $80 + 64\pi$

- 16 John is going to line up his four golf trophies on a shelf in his bedroom. How many different possible arrangements can he make?
- 1) 24
 - 2) 16
 - 3) 10
 - 4) 4

17 A rectangle has an area of 24 square units. The width is 5 units less than the length. What is the length, in units, of the rectangle?

- 1) 6
- 2) 8
- 3) 3
- 4) 19

18 What is the value of the third quartile shown on the box-and-whisker plot below?

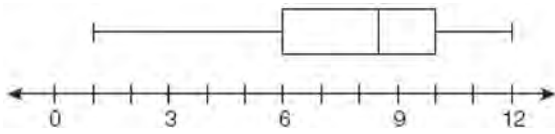

- 1) 6
- 2) 8.5
- 3) 10
- 4) 12

19 When $3g^2 - 4g + 2$ is subtracted from $7g^2 + 5g - 1$, the difference is

- 1) $-4g^2 - 9g + 3$
- 2) $4g^2 + g + 1$
- 3) $4g^2 + 9g - 3$
- 4) $10g^2 + g + 1$

20 Which value of x is the solution of

$$\frac{2x}{5} + \frac{1}{3} = \frac{7x-2}{15}?$$

- 1) $\frac{3}{5}$
- 2) $\frac{31}{26}$
- 3) 3
- 4) 7

21 Which expression represents $\frac{25x - 125}{x^2 - 25}$ in simplest form?

- 1) $\frac{5}{x}$
- 2) $\frac{-5}{x}$
- 3) $\frac{25}{x-5}$
- 4) $\frac{25}{x+5}$

22 Which equation most closely represents the line of best fit for the scatter plot below?



- 1) $y = x$
- 2) $y = \frac{2}{3}x + 1$
- 3) $y = \frac{3}{2}x + 4$
- 4) $y = \frac{3}{2}x + 1$

- 23 In a linear equation, the independent variable increases at a constant rate while the dependent variable decreases at a constant rate. The slope of this line is
- 1) zero
 - 2) negative
 - 3) positive
 - 4) undefined

- 24 Which equation could be used to find the measure of one acute angle in the right triangle shown below?

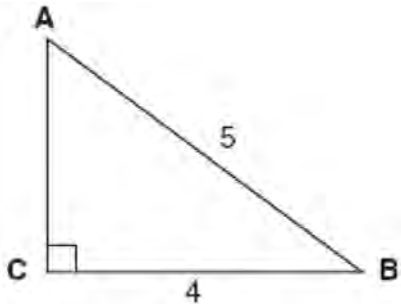

- 1) $\sin A = \frac{4}{5}$
- 2) $\tan A = \frac{5}{4}$
- 3) $\cos B = \frac{5}{4}$
- 4) $\tan B = \frac{4}{5}$

- 25 Which ordered pair is in the solution set of the following system of inequalities?

$$y < \frac{1}{2}x + 4$$

$$y \geq -x + 1$$

- 1) (-5,3)
- 2) (0,4)
- 3) (3,-5)
- 4) (4,0)

- 26 What is the product of $\frac{4x}{x-1}$ and $\frac{x^2-1}{3x+3}$ expressed in simplest form?

- 1) $\frac{4x}{3}$
- 2) $\frac{4x^2}{3}$
- 3) $\frac{4x^2}{3(x+1)}$
- 4) $\frac{4(x+1)}{3}$

- 27 Which expression is equivalent to $(3x^2)^3$?

- 1) $9x^5$
- 2) $9x^6$
- 3) $27x^5$
- 4) $27x^6$

- 28 Ryan estimates the measurement of the volume of a popcorn container to be 282 cubic inches. The actual volume of the popcorn container is 289 cubic inches. What is the relative error of Ryan's measurement to the *nearest thousandth*?
- 1) 0.024
 - 2) 0.025
 - 3) 0.096
 - 4) 1.025

- 29 In the diagram of $\triangle ABC$ shown below, $BC = 10$ and $AB = 16$.

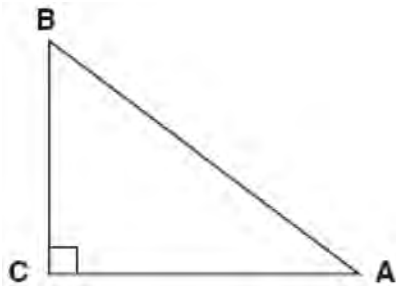

To the *nearest tenth of a degree*, what is the measure of the largest acute angle in the triangle?

- 1) 32.0
- 2) 38.7
- 3) 51.3
- 4) 90.0

- 30 The faces of a cube are numbered from 1 to 6. If the cube is tossed once, what is the probability that a prime number or a number divisible by 2 is obtained?

- 1) $\frac{6}{6}$
- 2) $\frac{5}{6}$
- 3) $\frac{4}{6}$
- 4) $\frac{1}{6}$

- 31 In a game of ice hockey, the hockey puck took 0.8 second to travel 89 feet to the goal line. Determine the average speed of the puck in feet per second.

- 32 Brianna is using the two spinners shown below to play her new board game. She spins the arrow on each spinner once. Brianna uses the first spinner to determine how many spaces to move. She uses the second spinner to determine whether her move from the first spinner will be forward or backward.



Find the probability that Brianna will move *fewer than four spaces and backward*.

33 Twelve players make up a high school basketball team. The team jerseys are numbered 1 through 12. The players wearing the jerseys numbered 3, 6, 7, 8, and 11 are the only players who start a game. Using set notation, list the complement of this subset.

34 Express the product of $3\sqrt{20}(2\sqrt{5} - 7)$ in simplest radical form.

35 On the set of axes below, draw the graph of $y = 2^x$ over the interval $-1 \leq x \leq 3$. Will this graph ever intersect the x -axis? Justify your answer.

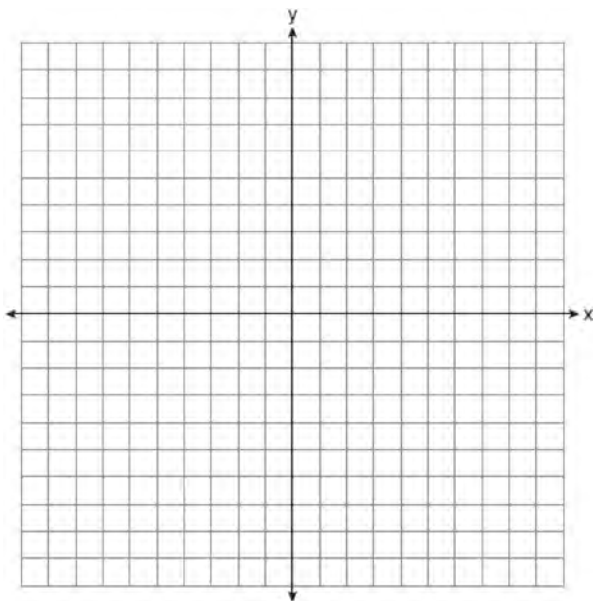

36 Write an equation that represents the line that passes through the points $(5,4)$ and $(-5,0)$.

37 The cost of 3 markers and 2 pencils is \$1.80. The cost of 4 markers and 6 pencils is \$2.90. What is the cost of *each* item? Include appropriate units in your answer.

38 Twenty students were surveyed about the number of days they played outside in one week. The results of this survey are shown below.

{6,5,4,3,0,7,1,5,4,4,3,2,2,3,2,4,3,4,0,7}

Complete the frequency table below for these data.

Interval	Tally	Frequency
0–1		
2–3		
4–5		
6–7		

Complete the cumulative frequency table below using these data.

Number of Days Outside

Interval	Cumulative Frequency
0–1	
0–3	
0–5	
0–7	

On the grid below, create a cumulative frequency histogram based on the table you made.

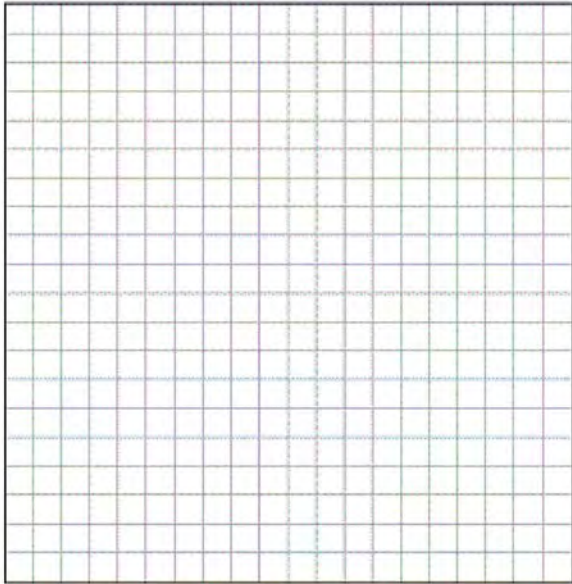

- 39 On the set of axes below, solve the following system of equations graphically and state the coordinates of all points in the solution set.

$$y = x^2 + 4x - 5$$

$$y = x - 1$$

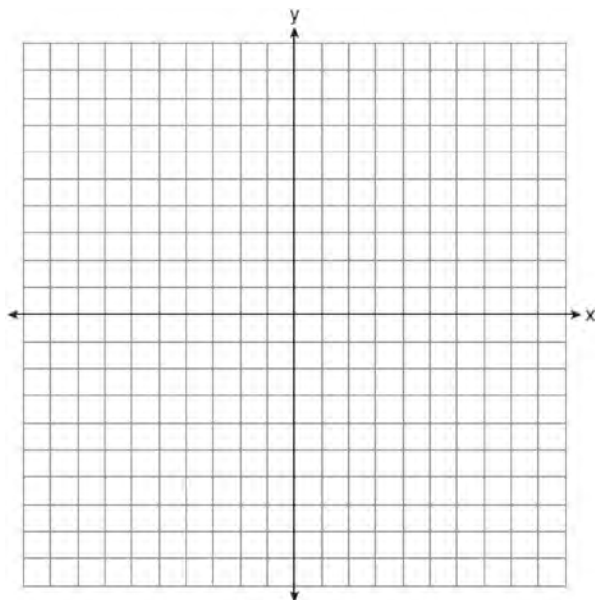

0109ia

- 1 On a certain day in Toronto, Canada, the temperature was 15° Celsius (C). Using the formula $F = \frac{9}{5}C + 32$, Peter converts this temperature to degrees Fahrenheit (F). Which temperature represents 15°C in degrees Fahrenheit?
 - 1) -9
 - 2) 35
 - 3) 59
 - 4) 85

- 2 What is the speed, in meters per second, of a paper airplane that flies 24 meters in 6 seconds?
 - 1) 144
 - 2) 30
 - 3) 18
 - 4) 4

- 3 The faces of a cube are numbered from 1 to 6. If the cube is rolled once, which outcome is *least* likely to occur?
 - 1) rolling an odd number
 - 2) rolling an even number
 - 3) rolling a number less than 6
 - 4) rolling a number greater than 4

- 4 Tamara has a cell phone plan that charges \$0.07 per minute plus a monthly fee of \$19.00. She budgets \$29.50 per month for total cell phone expenses without taxes. What is the maximum number of minutes Tamara could use her phone each month in order to stay within her budget?
 - 1) 150
 - 2) 271
 - 3) 421
 - 4) 692

- 5 Antwaan leaves a cup of hot chocolate on the counter in his kitchen. Which graph is the best representation of the change in temperature of his hot chocolate over time?

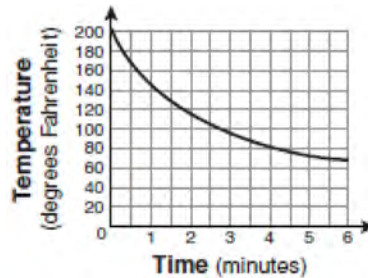

1)

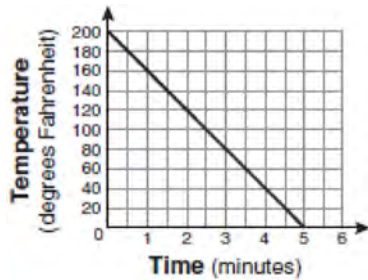

2)

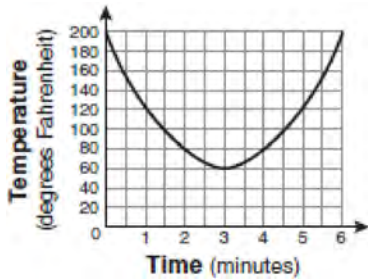

3)

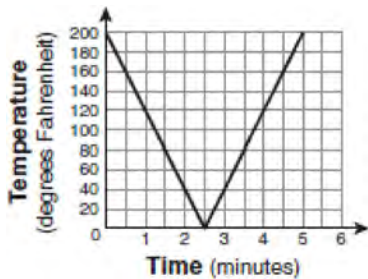

4)

- 6 What is the solution of $\frac{k+4}{2} = \frac{k+9}{3}$?
- 1) 1
 - 2) 5
 - 3) 6
 - 4) 14
- 7 Alex earned scores of 60, 74, 82, 87, 87, and 94 on his first six algebra tests. What is the relationship between the measures of central tendency of these scores?
- 1) median < mode < mean
 - 2) mean < mode < median
 - 3) mode < median < mean
 - 4) mean < median < mode
- 8 The New York Volleyball Association invited 64 teams to compete in a tournament. After each round, half of the teams were eliminated. Which equation represents the number of teams, t , that remained in the tournament after r rounds?
- 1) $t = 64(r)^{0.5}$
 - 2) $t = 64(-0.5)^r$
 - 3) $t = 64(1.5)^r$
 - 4) $t = 64(0.5)^r$
- 9 The expression $9x^2 - 100$ is equivalent to
- 1) $(9x - 10)(x + 10)$
 - 2) $(3x - 10)(3x + 10)$
 - 3) $(3x - 100)(3x - 1)$
 - 4) $(9x - 100)(x + 1)$

- 10 What is an equation of the line that passes through the points $(3, -3)$ and $(-3, -3)$?
- 1) $y = 3$
 - 2) $x = -3$
 - 3) $y = -3$
 - 4) $x = y$
- 11 If the formula for the perimeter of a rectangle is $P = 2l + 2w$, then w can be expressed as
- 1) $w = \frac{2l - P}{2}$
 - 2) $w = \frac{P - 2l}{2}$
 - 3) $w = \frac{P - l}{2}$
 - 4) $w = \frac{P - 2w}{2l}$

- 12 In the right triangle shown in the diagram below, what is the value of x to the *nearest whole number*?

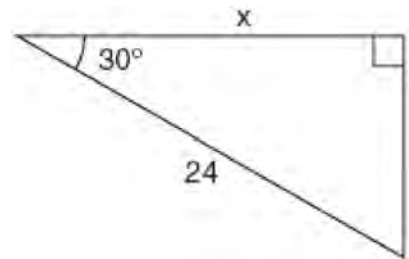

- 1) 12
- 2) 14
- 3) 21
- 4) 28

13 What is the slope of the line that passes through the points (2,5) and (7,3)?

- 1) $-\frac{5}{2}$
- 2) $-\frac{2}{5}$
- 3) $\frac{8}{9}$
- 4) $\frac{9}{8}$

14 What are the roots of the equation

$$x^2 - 10x + 21 = 0?$$

- 1) 1 and 21
- 2) -5 and -5
- 3) 3 and 7
- 4) -3 and -7

15 Rhonda has \$1.35 in nickels and dimes in her pocket. If she has six more dimes than nickels, which equation can be used to determine x , the number of nickels she has?

- 1) $0.05(x + 6) + 0.10x = 1.35$
- 2) $0.05x + 0.10(x + 6) = 1.35$
- 3) $0.05 + 0.10(6x) = 1.35$
- 4) $0.15(x + 6) = 1.35$

16 Which equation represents the axis of symmetry of the graph of the parabola below?

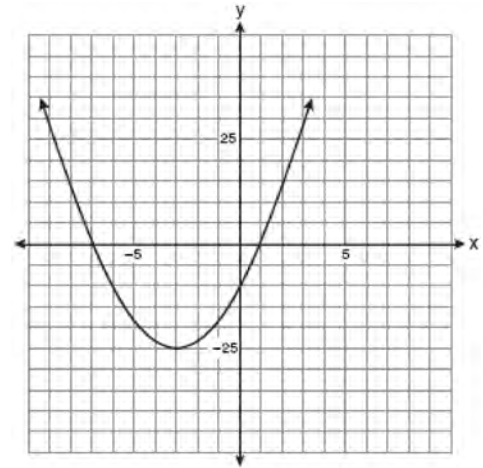

- 1) $y = -3$
- 2) $x = -3$
- 3) $y = -25$
- 4) $x = -25$

17 The set {1,2,3,4} is equivalent to

- 1) $\{x \mid 1 < x < 4, \text{ where } x \text{ is a whole number}\}$
- 2) $\{x \mid 0 < x < 4, \text{ where } x \text{ is a whole number}\}$
- 3) $\{x \mid 0 < x \leq 4, \text{ where } x \text{ is a whole number}\}$
- 4) $\{x \mid 1 < x \leq 4, \text{ where } x \text{ is a whole number}\}$

18 What is the value of x in the equation $\frac{2}{x} - 3 = \frac{26}{x}$?

- 1) -8
- 2) $-\frac{1}{8}$
- 3) $\frac{1}{8}$
- 4) 8

19 The diagram below shows right triangle UPC .

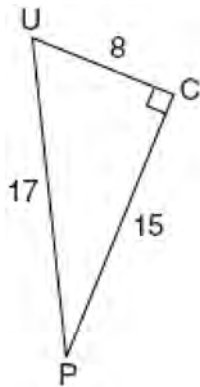

Which ratio represents the sine of $\angle U$?

- 1) $\frac{15}{8}$
- 2) $\frac{15}{17}$
- 3) $\frac{8}{15}$
- 4) $\frac{8}{17}$

20 What is $\sqrt{72}$ expressed in simplest radical form?

- 1) $2\sqrt{18}$
- 2) $3\sqrt{8}$
- 3) $6\sqrt{2}$
- 4) $8\sqrt{3}$

21 What is $\frac{6}{5x} - \frac{2}{3x}$ in simplest form?

- 1) $\frac{8}{15x^2}$
- 2) $\frac{8}{15x}$
- 3) $\frac{4}{15x}$
- 4) $\frac{4}{2x}$

22 Which ordered pair is a solution of the system of equations $y = x^2 - x - 20$ and $y = 3x - 15$?

- 1) $(-5, -30)$
- 2) $(-1, -18)$
- 3) $(0, 5)$
- 4) $(5, -1)$

23 A survey is being conducted to determine which types of television programs people watch. Which survey and location combination would likely contain the most bias?

- 1) surveying 10 people who work in a sporting goods store
- 2) surveying the first 25 people who enter a grocery store
- 3) randomly surveying 50 people during the day in a mall
- 4) randomly surveying 75 people during the day in a clothing store

24 The length of a rectangular room is 7 less than three times the width, w , of the room. Which expression represents the area of the room?

- 1) $3w - 4$
- 2) $3w - 7$
- 3) $3w^2 - 4w$
- 4) $3w^2 - 7w$

25 The function $y = \frac{x}{x^2 - 9}$ is undefined when the value of x is

- 1) 0 or 3
- 2) 3 or -3
- 3) 3, only
- 4) -3 , only

26 Which equation represents a line that is parallel to the line $y = 3 - 2x$?

- 1) $4x + 2y = 5$
- 2) $2x + 4y = 1$
- 3) $y = 3 - 4x$
- 4) $y = 4x - 2$

27 What is the product of 8.4×10^8 and 4.2×10^3 written in scientific notation?

- 1) 2.0×10^5
- 2) 12.6×10^{11}
- 3) 35.28×10^{11}
- 4) 3.528×10^{12}

28 Keisha is playing a game using a wheel divided into eight equal sectors, as shown in the diagram below. Each time the spinner lands on orange, she will win a prize.

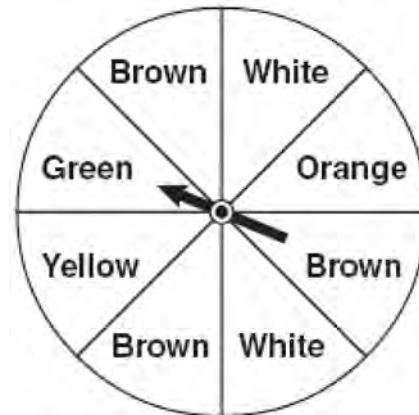

If Keisha spins this wheel twice, what is the probability she will win a prize on *both* spins?

- 1) $\frac{1}{64}$
- 2) $\frac{1}{56}$
- 3) $\frac{1}{16}$
- 4) $\frac{1}{4}$

- 29 A movie theater recorded the number of tickets sold daily for a popular movie during the month of June. The box-and-whisker plot shown below represents the data for the number of tickets sold, in hundreds.

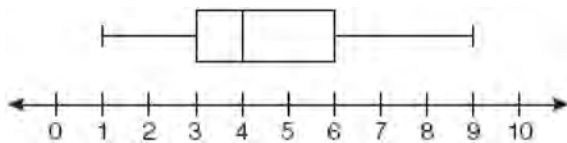

Which conclusion can be made using this plot?

- 1) The second quartile is 600.
- 2) The mean of the attendance is 400.
- 3) The range of the attendance is 300 to 600.
- 4) Twenty-five percent of the attendance is between 300 and 400.

- 30 Which graph represents a function?

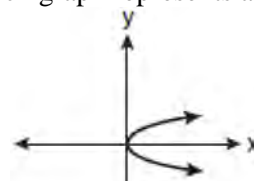

1)

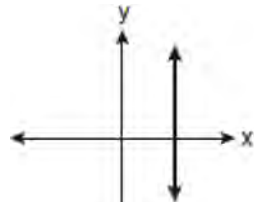

2)

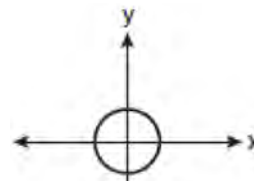

3)

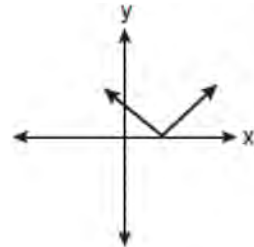

4)

- 31 A window is made up of a single piece of glass in the shape of a semicircle and a rectangle, as shown in the diagram below. Tess is decorating for a party and wants to put a string of lights all the way around the outside edge of the window.

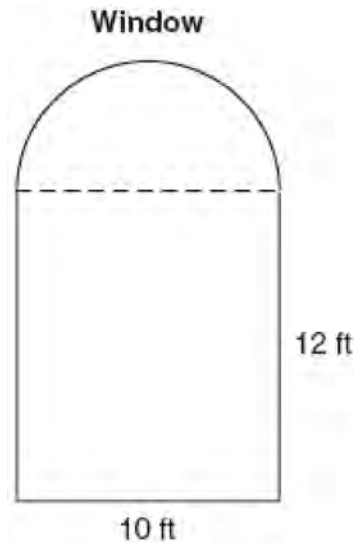

To the *nearest foot*, what is the length of the string of lights that Tess will need to decorate the window?

32 Simplify: $\frac{27k^5 m^8}{(4k^3)(9m^2)}$

- 33 The table below represents the number of hours a student worked and the amount of money the student earned.

Number of Hours (h)	Dollars Earned (d)
8	\$50.00
15	\$93.75
19	\$118.75
30	\$187.50

Write an equation that represents the number of dollars, d , earned in terms of the number of hours, h , worked. Using this equation, determine the number of dollars the student would earn for working 40 hours.

- 34 Sarah measures her rectangular bedroom window for a new shade. Her measurements are 36 inches by 42 inches. The actual measurements of the window are 36.5 inches and 42.5 inches. Using the measurements that Sarah took, determine the number of square inches in the area of the window. Determine the number of square inches in the actual area of the window. Determine the relative error in calculating the area. Express your answer as a decimal to the *nearest thousandth*.

- 35 Perform the indicated operation and simplify:

$$\frac{3x+6}{4x+12} \div \frac{x^2-4}{x+3}$$

36 A soup can is in the shape of a cylinder. The can has a volume of 342 cm^3 and a diameter of 6 cm. Express the height of the can in terms of π . Determine the maximum number of soup cans that can be stacked on their base between two shelves if the distance between the shelves is exactly 36 cm. Explain your answer.

37 Solve the following system of equations algebraically:

$$3x + 2y = 4$$

$$4x + 3y = 7$$

[Only an algebraic solution can receive full credit.]

38 On the set of axes below, graph the following system of inequalities and state the coordinates of a point in the solution set.

$$2x - y \geq 6$$

$$x > 2$$

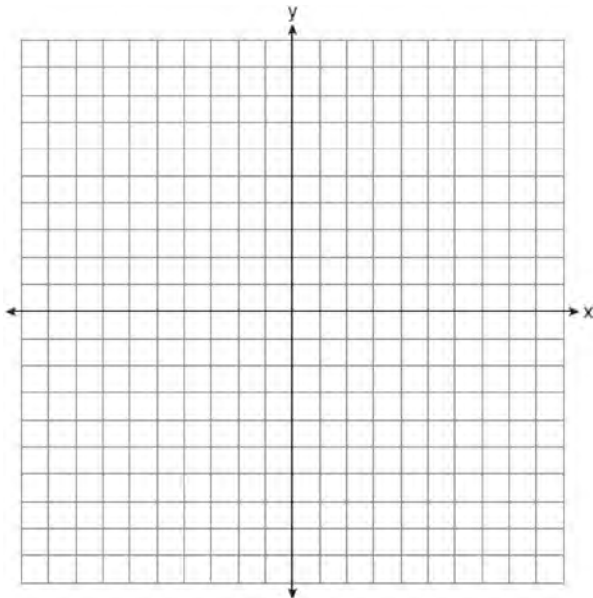

39 A restaurant sells kids' meals consisting of one main course, one side dish, and one drink, as shown in the table below.

Kids' Meal Choices

Main Course	Side Dish	Drink
hamburger	French fries	milk
chicken nuggets	applesauce	juice
turkey sandwich		soda

Draw a tree diagram or list the sample space showing all possible kids' meals. How many different kids' meals can a person order? Jose does not drink juice. Determine the number of different kids' meals that do *not* include juice. Jose's sister will eat *only* chicken nuggets for her main course. Determine the number of different kids' meals that include chicken nuggets.

0609ia

- 1 It takes Tammy 45 minutes to ride her bike 5 miles. At this rate, how long will it take her to ride 8 miles?
- 1) 0.89 hour
 - 2) 1.125 hours
 - 3) 48 minutes
 - 4) 72 minutes

- 2 What are the roots of the equation $x^2 - 7x + 6 = 0$?
- 1) 1 and 7
 - 2) -1 and 7
 - 3) -1 and -6
 - 4) 1 and 6

- 3 Which expression represents $\frac{27x^{18}y^5}{9x^6y}$ in simplest form?
- 1) $3x^{12}y^4$
 - 2) $3x^3y^5$
 - 3) $18x^{12}y^4$
 - 4) $18x^3y^5$

- 4 Marie currently has a collection of 58 stamps. If she buys s stamps each week for w weeks, which expression represents the total number of stamps she will have?
- 1) $58sw$
 - 2) $58 + sw$
 - 3) $58s + w$
 - 4) $58 + s + w$

- 5 Which data set describes a situation that could be classified as qualitative?
- 1) the ages of the students in Ms. Marshall's Spanish class
 - 2) the test scores of the students in Ms. Fitzgerald's class
 - 3) the favorite ice cream flavor of each of Mr. Hayden's students
 - 4) the heights of the players on the East High School basketball team

- 6 The sign shown below is posted in front of a roller coaster ride at the Wadsworth County Fairgrounds.

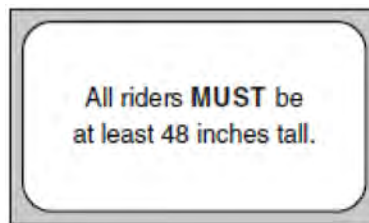

If h represents the height of a rider in inches, what is a correct translation of the statement on this sign?

- 1) $h < 48$
 - 2) $h > 48$
 - 3) $h \leq 48$
 - 4) $h \geq 48$
- 7 Which value of x is the solution of the equation $\frac{2x}{3} + \frac{x}{6} = 5$?
- 1) 6
 - 2) 10
 - 3) 15
 - 4) 30

- 8 Students in Ms. Nazzeer's mathematics class tossed a six-sided number cube whose faces are numbered 1 to 6. The results are recorded in the table below.

Result	Frequency
1	3
2	6
3	4
4	6
5	4
6	7

Based on these data, what is the empirical probability of tossing a 4?

- 1) $\frac{8}{30}$
 - 2) $\frac{6}{30}$
 - 3) $\frac{5}{30}$
 - 4) $\frac{1}{30}$
- 9 What is the value of x , in inches, in the right triangle below?

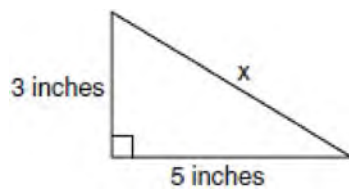

- 1) $\sqrt{15}$
- 2) 8
- 3) $\sqrt{34}$
- 4) 4

- 10 What is $\sqrt{32}$ expressed in simplest radical form?

- 1) $16\sqrt{2}$
- 2) $4\sqrt{2}$
- 3) $4\sqrt{8}$
- 4) $2\sqrt{8}$

- 11 If the speed of sound is 344 meters per second, what is the approximate speed of sound, in meters per hour?

60 seconds = 1 minute
60 minutes = 1 hour

- 1) 20,640
- 2) 41,280
- 3) 123,840
- 4) 1,238,400

- 12 The sum of two numbers is 47, and their difference is 15. What is the larger number?

- 1) 16
- 2) 31
- 3) 32
- 4) 36

- 13 If $a + ar = b + r$, the value of a in terms of b and r can be expressed as

- 1) $\frac{b}{r} + 1$
- 2) $\frac{1+b}{r}$
- 3) $\frac{b+r}{1+r}$
- 4) $\frac{1+b}{r+b}$

- 14 Which value of x is in the solution set of

$$\frac{4}{3}x + 5 < 17?$$

- 1) 8
- 2) 9
- 3) 12
- 4) 16

- 15 The box-and-whisker plot below represents students' scores on a recent English test.

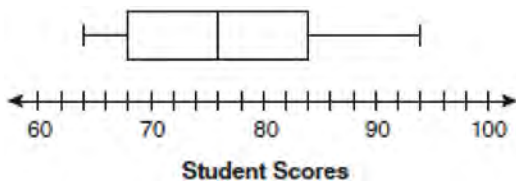

What is the value of the upper quartile?

- 1) 68
- 2) 76
- 3) 84
- 4) 94

- 16 Which value of n makes the expression $\frac{5n}{2n-1}$

undefined?

- 1) 1
- 2) 0
- 3) $-\frac{1}{2}$
- 4) $\frac{1}{2}$

- 17 At Genesee High School, the sophomore class has 60 more students than the freshman class. The junior class has 50 fewer students than twice the students in the freshman class. The senior class is three times as large as the freshman class. If there are a total of 1,424 students at Genesee High School, how many students are in the freshman class?

- 1) 202
- 2) 205
- 3) 235
- 4) 236

- 18 What are the vertex and axis of symmetry of the parabola $y = x^2 - 16x + 63$?

- 1) vertex: $(8, -1)$; axis of symmetry: $x = 8$
- 2) vertex: $(8, 1)$; axis of symmetry: $x = 8$
- 3) vertex: $(-8, -1)$; axis of symmetry: $x = -8$
- 4) vertex: $(-8, 1)$; axis of symmetry: $x = -8$

19 Which statement is true about the relation shown on the graph below?

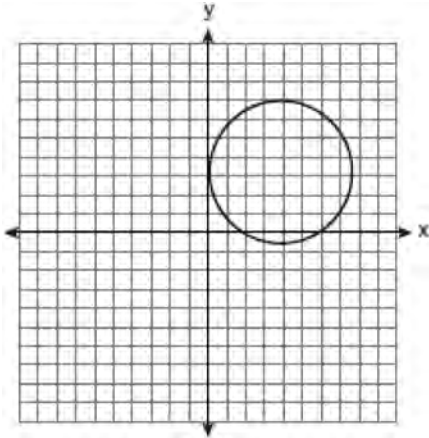

- 1) It is a function because there exists one x -coordinate for each y -coordinate.
- 2) It is a function because there exists one y -coordinate for each x -coordinate.
- 3) It is *not* a function because there are multiple y -values for a given x -value.
- 4) It is *not* a function because there are multiple x -values for a given y -value.

20 Which graph represents the solution of $3y - 9 \leq 6x$?

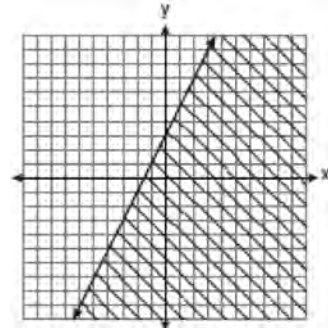

1)

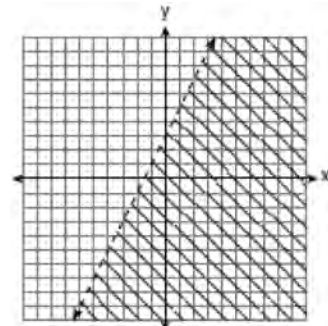

2)

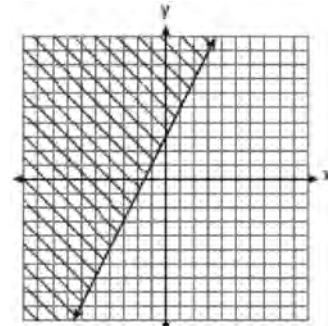

3)

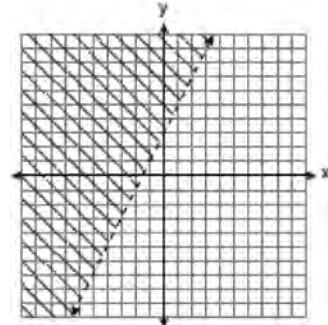

4)

21 Which expression represents $\frac{x^2 - 2x - 15}{x^2 + 3x}$ in

simplest form?

- 1) -5
- 2) $\frac{x-5}{x}$
- 3) $\frac{-2x-5}{x}$
- 4) $\frac{-2x-15}{3x}$

22 What is an equation of the line that passes through the point $(4, -6)$ and has a slope of -3 ?

- 1) $y = -3x + 6$
- 2) $y = -3x - 6$
- 3) $y = -3x + 10$
- 4) $y = -3x + 14$

23 When $4x^2 + 7x - 5$ is subtracted from $9x^2 - 2x + 3$, the result is

- 1) $5x^2 + 5x - 2$
- 2) $5x^2 - 9x + 8$
- 3) $-5x^2 + 5x - 2$
- 4) $-5x^2 + 9x - 8$

24 The equation $y = x^2 + 3x - 18$ is graphed on the set of axes below.

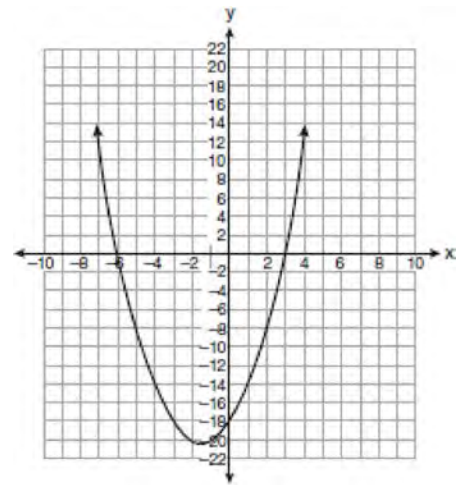

Based on this graph, what are the roots of the equation $x^2 + 3x - 18 = 0$?

- 1) -3 and 6
- 2) 0 and -18
- 3) 3 and -6
- 4) 3 and -18

25 What is the value of the y-coordinate of the solution to the system of equations $x + 2y = 9$ and $x - y = 3$?

- 1) 6
- 2) 2
- 3) 3
- 4) 5

26 What is the additive inverse of the expression $a - b$?

- 1) $a + b$
- 2) $a - b$
- 3) $-a + b$
- 4) $-a - b$

27 What is the product of 12 and 4.2×10^6 expressed in scientific notation?

- 1) 50.4×10^6
- 2) 50.4×10^7
- 3) 5.04×10^6
- 4) 5.04×10^7

28 To calculate the volume of a small wooden cube, Ezra measured an edge of the cube as 2 cm. The actual length of the edge of Ezra's cube is 2.1 cm. What is the relative error in his volume calculation to the nearest hundredth?

- 1) 0.13
- 2) 0.14
- 3) 0.15
- 4) 0.16

29 What is $\frac{6}{4a} - \frac{2}{3a}$ expressed in simplest form?

- 1) $\frac{4}{a}$
- 2) $\frac{5}{6a}$
- 3) $\frac{8}{7a}$
- 4) $\frac{10}{12a}$

30 The set $\{11, 12\}$ is equivalent to

- 1) $\{x | 11 < x < 12, \text{ where } x \text{ is an integer}\}$
- 2) $\{x | 11 < x \leq 12, \text{ where } x \text{ is an integer}\}$
- 3) $\{x | 10 \leq x < 12, \text{ where } x \text{ is an integer}\}$
- 4) $\{x | 10 < x \leq 12, \text{ where } x \text{ is an integer}\}$

31 Determine how many three-letter arrangements are possible with the letters $A, N, G, L,$ and E if no letter may be repeated.

32 Factor completely: $4x^3 - 36x$

33 Some books are laid on a desk. Two are English, three are mathematics, one is French, and four are social studies. Theresa selects an English book and Isabelle then selects a social studies book. Both girls take their selections to the library to read. If Truman then selects a book at random, what is the probability that he selects an English book?

34 In the diagram below, the circumference of circle O is 16π inches. The length of \overline{BC} is three-quarters of the length of diameter \overline{AD} and $CE = 4$ inches. Calculate the area, in square inches, of trapezoid $ABCD$.

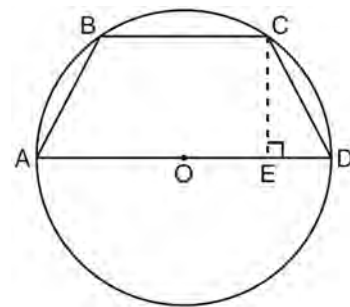

35 A bank is advertising that new customers can open a savings account with a $3\frac{3}{4}\%$ interest rate compounded annually. Robert invests \$5,000 in an account at this rate. If he makes no additional deposits or withdrawals on his account, find the amount of money he will have, to the *nearest cent*, after three years.

36 The table below shows the number of prom tickets sold over a ten-day period.

Prom Ticket Sales

Day (x)	1	2	5	7	10
Number of Prom Tickets Sold (y)	30	35	55	60	70

Plot these data points on the coordinate grid below. Use a consistent and appropriate scale. Draw a reasonable line of best fit and write its equation.

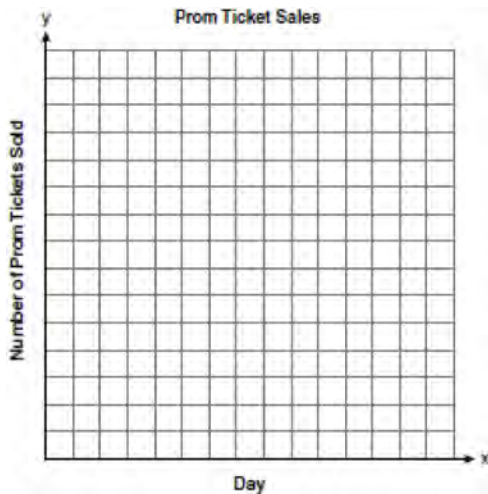

37 A stake is to be driven into the ground away from the base of a 50-foot pole, as shown in the diagram below. A wire from the stake on the ground to the top of the pole is to be installed at an angle of elevation of 52° .

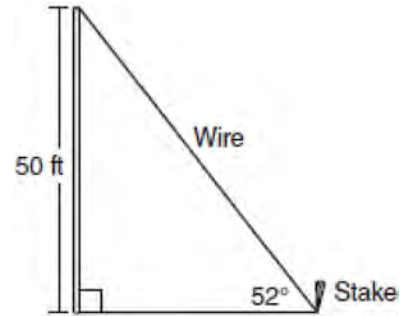

How far away from the base of the pole should the stake be driven in, to the *nearest foot*? What will be the length of the wire from the stake to the top of the pole, to the *nearest foot*?

Integrated Algebra Regents Exam 0609

www.jmap.org

- 38 The Fahrenheit temperature readings on 30 April mornings in Stormville, New York, are shown below.

41°, 58°, 61°, 54°, 49°, 46°, 52°, 58°, 67°, 43°,
 47°, 60°, 52°, 58°, 48°, 44°, 59°, 66°, 62°, 55°,
 44°, 49°, 62°, 61°, 59°, 54°, 57°, 58°, 63°, 60°

Using the data, complete the frequency table below.

Interval	Tally	Frequency
40–44		
45–49		
50–54		
55–59		
60–64		
65–69		

On the grid below, construct and label a frequency histogram based on the table.

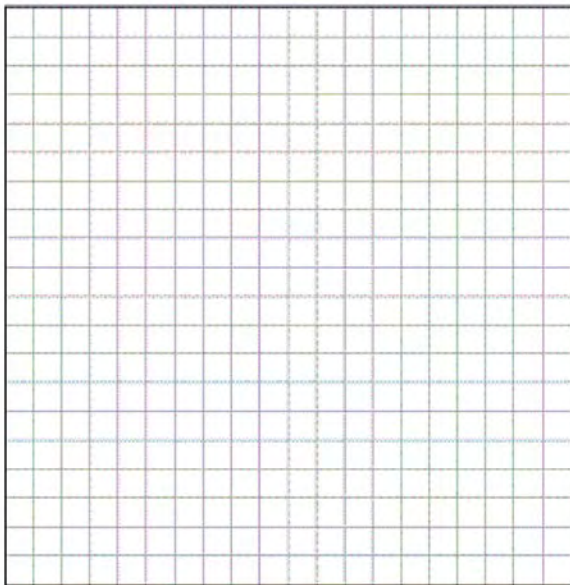

- 39 On the set of axes below, solve the following system of equations graphically for all values of x and y .

$$y = x^2 - 6x + 1$$

$$y + 2x = 6$$

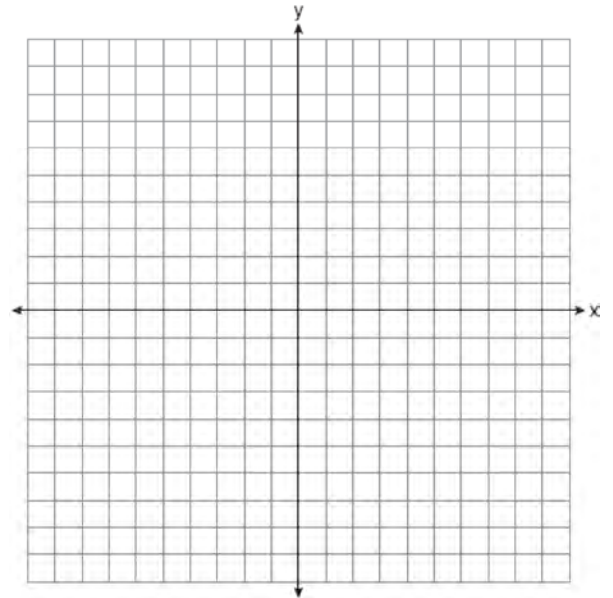

0809ia

- 1 If h represents a number, which equation is a correct translation of "Sixty more than 9 times a number is 375"?

- 1) $9h = 375$
- 2) $9h + 60 = 375$
- 3) $9h - 60 = 375$
- 4) $60h + 9 = 375$

- 2 Which expression is equivalent to $9x^2 - 16$?

- 1) $(3x + 4)(3x - 4)$
- 2) $(3x - 4)(3x - 4)$
- 3) $(3x + 8)(3x - 8)$
- 4) $(3x - 8)(3x - 8)$

- 3 Which expression represents $(3x^2y^4)(4xy^2)$ in simplest form?

- 1) $12x^2y^8$
- 2) $12x^2y^6$
- 3) $12x^3y^8$
- 4) $12x^3y^6$

- 4 An online music club has a one-time registration fee of \$13.95 and charges \$0.49 to buy each song. If Emma has \$50.00 to join the club and buy songs, what is the maximum number of songs she can buy?

- 1) 73
- 2) 74
- 3) 130
- 4) 131

- 5 The local ice cream stand offers three flavors of soft-serve ice cream: vanilla, chocolate, and strawberry; two types of cone: sugar and wafer; and three toppings: sprinkles, nuts, and cookie crumbs. If Dawn does not order vanilla ice cream, how many different choices can she make that have one flavor of ice cream, one type of cone, and one topping?

- 1) 7
- 2) 8
- 3) 12
- 4) 18

- 6 Nancy's rectangular garden is represented in the diagram below.

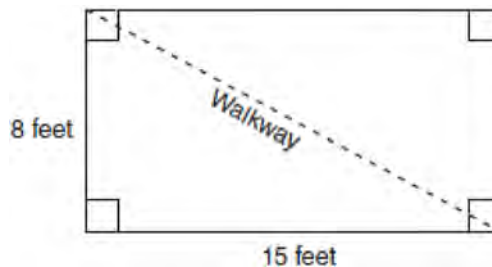

If a diagonal walkway crosses her garden, what is its length, in feet?

- 1) 17
- 2) 22
- 3) $\sqrt{161}$
- 4) $\sqrt{529}$

- 7 The spinner below is divided into eight equal regions and is spun once. What is the probability of *not* getting red?

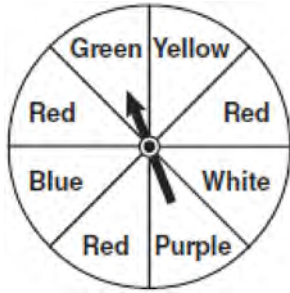

- 1) $\frac{3}{5}$
 2) $\frac{3}{8}$
 3) $\frac{5}{8}$
 4) $\frac{7}{8}$
- 8 Which relationship can best be described as causal?
 1) height and intelligence
 2) shoe size and running speed
 3) number of correct answers on a test and test score
 4) number of students in a class and number of students with brown hair

9 Solve for x : $\frac{3}{5}(x+2) = x-4$

- 1) 8
 2) 13
 3) 15
 4) 23

- 10 Erica is conducting a survey about the proposed increase in the sports budget in the Hometown School District. Which survey method would likely contain the most bias?
 1) Erica asks every third person entering the Hometown Grocery Store.
 2) Erica asks every third person leaving the Hometown Shopping Mall this weekend.
 3) Erica asks every fifth student entering Hometown High School on Monday morning.
 4) Erica asks every fifth person leaving Saturday's Hometown High School football game.

- 11 Which equation represents a line parallel to the x -axis?
 1) $y = -5$
 2) $y = -5x$
 3) $x = 3$
 4) $x = 3y$

- 12 Given:
 $A = \{\text{All even integers from 2 to 20, inclusive}\}$
 $B = \{10, 12, 14, 16, 18\}$
 What is the complement of set B within the universe of set A ?
 1) $\{4, 6, 8\}$
 2) $\{2, 4, 6, 8\}$
 3) $\{4, 6, 8, 20\}$
 4) $\{2, 4, 6, 8, 20\}$

- 13 Which value of x is in the solution set of the inequality $-2(x-5) < 4$?
 1) 0
 2) 2
 3) 3
 4) 5

- 14 A tree casts a 25-foot shadow on a sunny day, as shown in the diagram below.

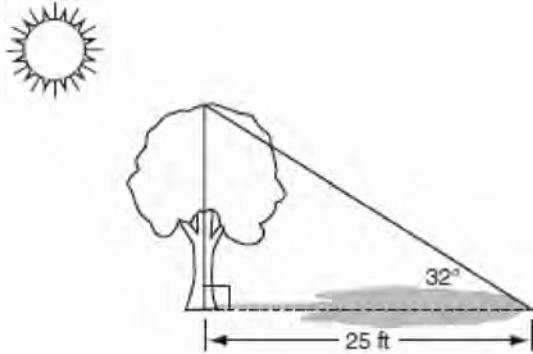

If the angle of elevation from the tip of the shadow to the top of the tree is 32° , what is the height of the tree to the nearest tenth of a foot?

- 1) 13.2
 - 2) 15.6
 - 3) 21.2
 - 4) 40.0
- 15 What is the slope of the line that passes through the points $(-5, 4)$ and $(15, -4)$?

- 1) $-\frac{2}{5}$
- 2) 0
- 3) $-\frac{5}{2}$
- 4) undefined

- 16 The equation $y = -x^2 - 2x + 8$ is graphed on the set of axes below.

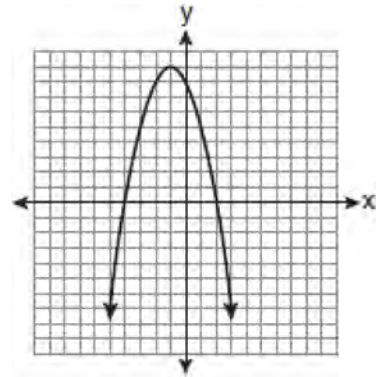

Based on this graph, what are the roots of the equation $-x^2 - 2x + 8 = 0$?

- 1) 8 and 0
 - 2) 2 and -4
 - 3) 9 and -1
 - 4) 4 and -2
- 17 What is the sum of $\frac{3}{2x}$ and $\frac{4}{3x}$ expressed in simplest form?

- 1) $\frac{12}{6x^2}$
- 2) $\frac{17}{6x}$
- 3) $\frac{7}{5x}$
- 4) $\frac{17}{12x}$

- 18 Which value of x makes the expression

$$\frac{x^2 - 9}{x^2 + 7x + 10} \text{ undefined?}$$

- 1) -5
- 2) 2
- 3) 3
- 4) -3

- 19 Which relation is *not* a function?

- 1) $\{(1, 5), (2, 6), (3, 6), (4, 7)\}$
- 2) $\{(4, 7), (2, 1), (-3, 6), (3, 4)\}$
- 3) $\{(-1, 6), (1, 3), (2, 5), (1, 7)\}$
- 4) $\{(-1, 2), (0, 5), (5, 0), (2, -1)\}$

- 20 What is the value of the y -coordinate of the solution to the system of equations $x - 2y = 1$ and $x + 4y = 7$?

- 1) 1
- 2) -1
- 3) 3
- 4) 4

- 21 The solution to the equation $x^2 - 6x = 0$ is

- 1) 0 , only
- 2) 6 , only
- 3) 0 and 6
- 4) $\pm\sqrt{6}$

- 22 When $5\sqrt{20}$ is written in simplest radical form, the result is $k\sqrt{5}$. What is the value of k ?

- 1) 20
- 2) 10
- 3) 7
- 4) 4

- 23 What is the value of the expression $|-5x + 12|$ when $x = 5$?

- 1) -37
- 2) -13
- 3) 13
- 4) 37

- 24 A playground in a local community consists of a rectangle and two semicircles, as shown in the diagram below.

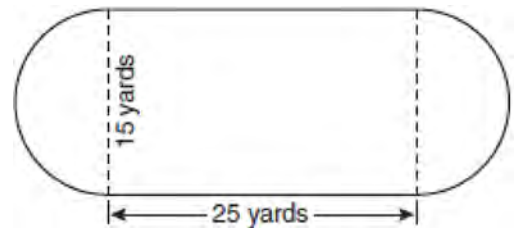

Which expression represents the amount of fencing, in yards, that would be needed to completely enclose the playground?

- 1) $15\pi + 50$
- 2) $15\pi + 80$
- 3) $30\pi + 50$
- 4) $30\pi + 80$

25 Which equation is represented by the graph below?

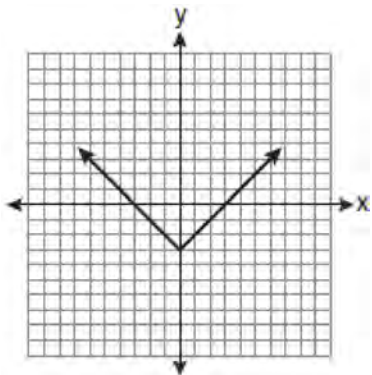

- 1) $y = x^2 - 3$
- 2) $y = (x - 3)^2$
- 3) $y = |x| - 3$
- 4) $y = |x - 3|$

26 Carrie bought new carpet for her living room. She calculated the area of the living room to be 174.2 square feet. The actual area was 149.6 square feet. What is the relative error of the area to the *nearest ten-thousandth*?

- 1) 0.1412
- 2) 0.1644
- 3) 1.8588
- 4) 2.1644

27 What is an equation of the line that passes through the point $(3, -1)$ and has a slope of 2?

- 1) $y = 2x + 5$
- 2) $y = 2x - 1$
- 3) $y = 2x - 4$
- 4) $y = 2x - 7$

28 The ages of three brothers are consecutive even integers. Three times the age of the youngest brother exceeds the oldest brother's age by 48 years. What is the age of the youngest brother?

- 1) 14
- 2) 18
- 3) 22
- 4) 26

29 Cassandra bought an antique dresser for \$500. If the value of her dresser increases 6% annually, what will be the value of Cassandra's dresser at the end of 3 years to the *nearest dollar*?

- 1) \$415
- 2) \$590
- 3) \$596
- 4) \$770

- 30 The number of hours spent on math homework each week and the final exam grades for twelve students in Mr. Dylan's algebra class are plotted below.

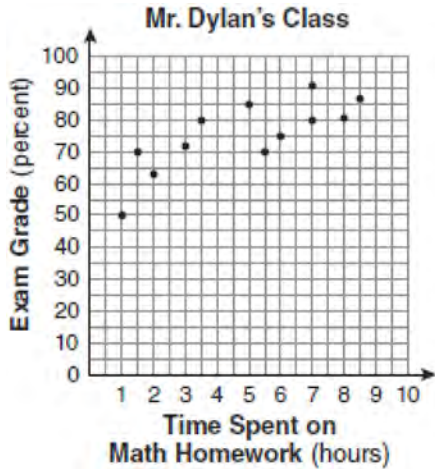

Based on a line of best fit, which exam grade is the best prediction for a student who spends about 4 hours on math homework each week?

- 1) 62
- 2) 72
- 3) 82
- 4) 92

- 31 Chad complained to his friend that he had five equations to solve for homework. Are all of the homework problems equations? Justify your answer.

Math Homework

1. $3x^2 \cdot 2x^4$
2. $5 - 2x = 3x$
3. $3(2x + 7)$
4. $7x^2 + 2x - 3x^2 - 9$
5. $\frac{2}{3} = \frac{x+2}{6}$

Name Chad

- 32 The diagram below represents Joe's two fish tanks.

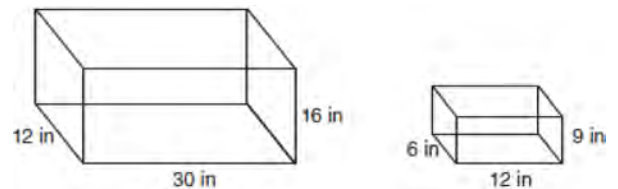

Joe's larger tank is completely filled with water. He takes water from it to completely fill the small tank. Determine how many cubic inches of water will remain in the larger tank.

- 33 Clayton has three fair coins. Find the probability that he gets two tails and one head when he flips the three coins.

34 Find algebraically the equation of the axis of symmetry and the coordinates of the vertex of the parabola whose equation is $y = -2x^2 - 8x + 3$.

35 At the end of week one, a stock had increased in value from \$5.75 a share to \$7.50 a share. Find the percent of increase at the end of week one to the *nearest tenth of a percent*. At the end of week two, the same stock had decreased in value from \$7.50 to \$5.75. Is the percent of decrease at the end of week two the same as the percent of increase at the end of week one? Justify your answer.

36 The chart below compares two runners.

Runner	Distance, in miles	Time, in hours
Greg	11	2
Dave	16	3

Based on the information in this chart, state which runner has the faster rate. Justify your answer.

37 Express in simplest form: $\frac{2x^2 - 8x - 42}{6x^2} \div \frac{x^2 - 9}{x^2 - 3x}$

38 On the grid below, solve the system of equations graphically for x and y .

$$4x - 2y = 10$$

$$y = -2x - 1$$

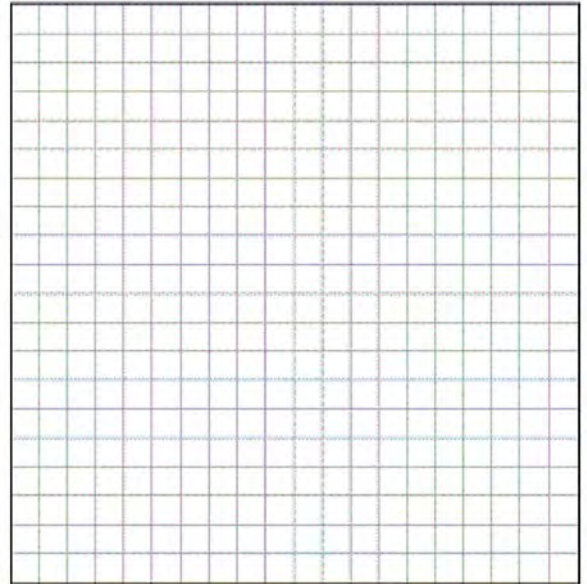

39 The test scores from Mrs. Gray's math class are shown below.

72, 73, 66, 71, 82, 85, 95, 85, 86, 89, 91, 92

Construct a box-and-whisker plot to display these data.

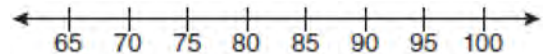

0110ia

- 1 The box-and-whisker plot below represents the math test scores of 20 students.

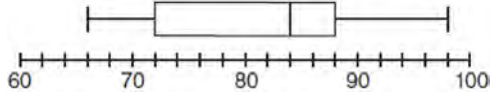

What percentage of the test scores are *less than* 72?

- 1) 25
 2) 50
 3) 75
 4) 100
- 2 A bag contains eight green marbles, five white marbles, and two red marbles. What is the probability of drawing a red marble from the bag?
- 1) $\frac{1}{15}$
 2) $\frac{2}{15}$
 3) $\frac{2}{13}$
 4) $\frac{13}{15}$
- 3 Julia went to the movies and bought one jumbo popcorn and two chocolate chip cookies for \$5.00. Marvin went to the same movie and bought one jumbo popcorn and four chocolate chip cookies for \$6.00. How much does one chocolate chip cookie cost?
- 1) \$0.50
 2) \$0.75
 3) \$1.00
 4) \$2.00

- 4 Given:

$$Q = \{0, 2, 4, 6\}$$

$$W = \{0, 1, 2, 3\}$$

$$Z = \{1, 2, 3, 4\}$$

What is the intersection of sets Q , W , and Z ?

- 1) $\{2\}$
 2) $\{0, 2\}$
 3) $\{1, 2, 3\}$
 4) $\{0, 1, 2, 3, 4, 6\}$
- 5 Roger is having a picnic for 78 guests. He plans to serve each guest at least one hot dog. If each package, p , contains eight hot dogs, which inequality could be used to determine how many packages of hot dogs Roger will need to buy?
- 1) $p \geq 78$
 2) $8p \geq 78$
 3) $8 + p \geq 78$
 4) $78 - p \geq 8$

- 6 In a science fiction novel, the main character found a mysterious rock that decreased in size each day. The table below shows the part of the rock that remained at noon on successive days.

Day	Fractional Part of the Rock Remaining
1	1
2	$\frac{1}{2}$
3	$\frac{1}{4}$
4	$\frac{1}{8}$

Which fractional part of the rock will remain at noon on day 7?

- 1) $\frac{1}{128}$
- 2) $\frac{1}{64}$
- 3) $\frac{1}{14}$
- 4) $\frac{1}{12}$

- 7 In the diagram below, what is the slope of the line passing through points A and B?

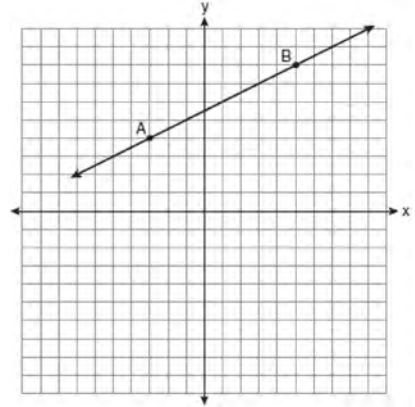

- 1) -2
- 2) 2
- 3) $-\frac{1}{2}$
- 4) $\frac{1}{2}$

- 8 Which equation shows a correct trigonometric ratio for angle A in the right triangle below?

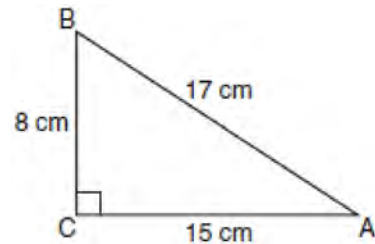

- 1) $\sin A = \frac{15}{17}$
- 2) $\tan A = \frac{8}{17}$
- 3) $\cos A = \frac{15}{17}$
- 4) $\tan A = \frac{5}{8}$

- 9 Debbie solved the linear equation $3(x + 4) - 2 = 16$ as follows:

[Line 1] $3(x + 4) - 2 = 16$

[Line 2] $3(x + 4) = 18$

[Line 3] $3x + 4 = 18$

[Line 4] $3x = 14$

[Line 5] $x = 4\frac{2}{3}$

She made an error between lines

- 1) 1 and 2
- 2) 2 and 3
- 3) 3 and 4
- 4) 4 and 5

- 10 The value of the expression $-|a - b|$ when $a = 7$ and $b = -3$ is

- 1) -10
- 2) 10
- 3) -4
- 4) 4

- 11 Which expression represents $\frac{12x^3 - 6x^2 + 2x}{2x}$ in simplest form?

- 1) $6x^2 - 3x$
- 2) $10x^2 - 4x$
- 3) $6x^2 - 3x + 1$
- 4) $10x^2 - 4x + 1$

- 12 Which ordered pair is a solution of the system of equations shown in the graph below?

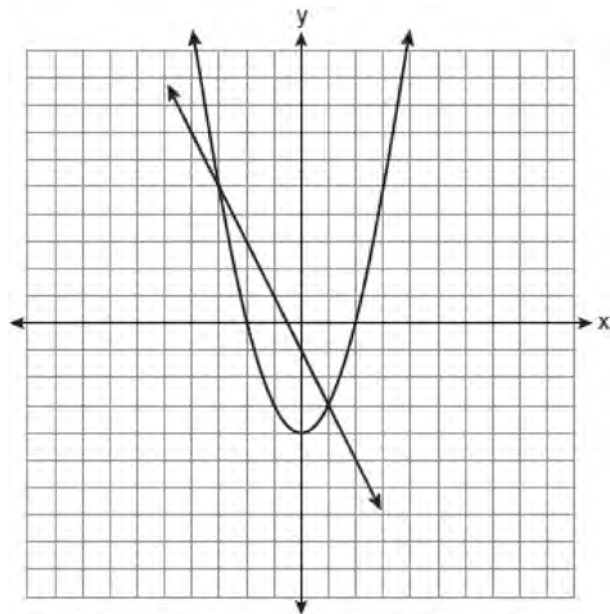

- 1) $(-3, 1)$
- 2) $(-3, 5)$
- 3) $(0, -1)$
- 4) $(0, -4)$

- 13 Which equation represents the line that passes through the points $(-3, 7)$ and $(3, 3)$?

- 1) $y = \frac{2}{3}x + 1$
- 2) $y = \frac{2}{3}x + 9$
- 3) $y = -\frac{2}{3}x + 5$
- 4) $y = -\frac{2}{3}x + 9$

14 Which data table represents univariate data?

1)

Side Length of a Square	Area of Square
2	4
3	9
4	16
5	25

2)

Hours Worked	Pay
20	\$160
25	\$200
30	\$240
35	\$280

3)

Age Group	Frequency
20–29	9
30–39	7
40–49	10
50–59	4

4)

People	Number of Fingers
2	20
3	30
4	40
5	50

15 What is the equation of the axis of symmetry of the parabola shown in the diagram below?

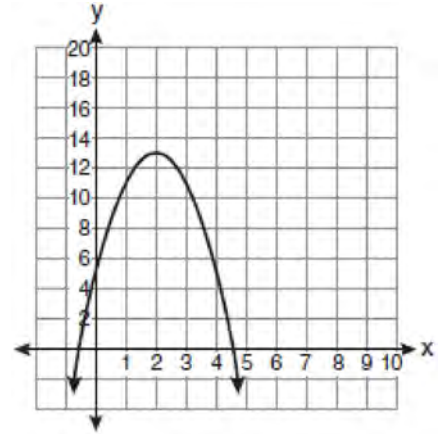

- 1) $x = -0.5$
- 2) $x = 2$
- 3) $x = 4.5$
- 4) $x = 13$

16 The members of the senior class are planning a dance. They use the equation $r = pn$ to determine the total receipts. What is n expressed in terms of r and p ?

- 1) $n = r + p$
- 2) $n = r - p$
- 3) $n = \frac{p}{r}$
- 4) $n = \frac{r}{p}$

- 17 The graph of the equation $y = |x|$ is shown in the diagram below.

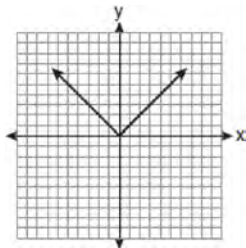

Which diagram could represent a graph of the equation $y = a|x|$ when $-1 < a < 0$?

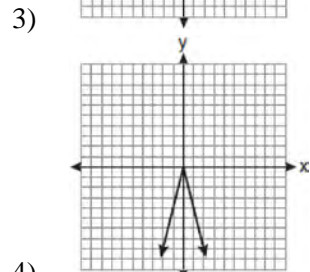
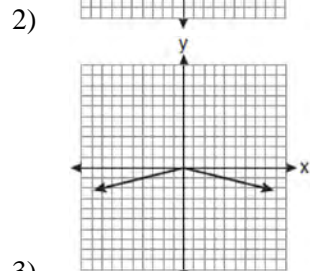
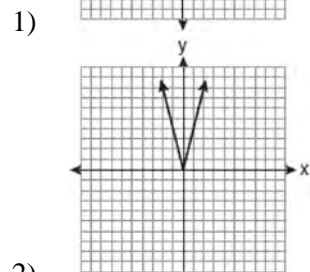
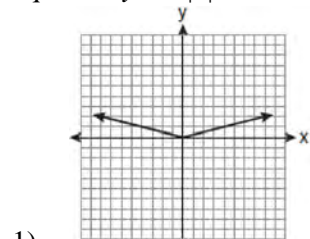

- 18 Which relation represents a function?

- 1) $\{(0, 3), (2, 4), (0, 6)\}$
- 2) $\{(-7, 5), (-7, 1), (-10, 3), (-4, 3)\}$
- 3) $\{(2, 0), (6, 2), (6, -2)\}$
- 4) $\{(-6, 5), (-3, 2), (1, 2), (6, 5)\}$

- 19 Which scatter plot shows the relationship between x and y if x represents a student score on a test and y represents the number of incorrect answers a student received on the same test?

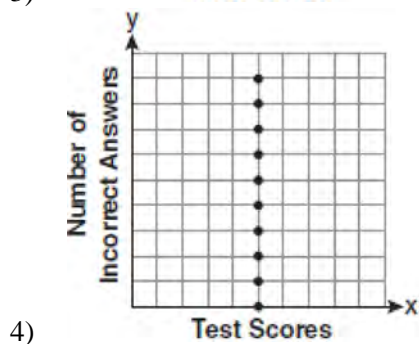
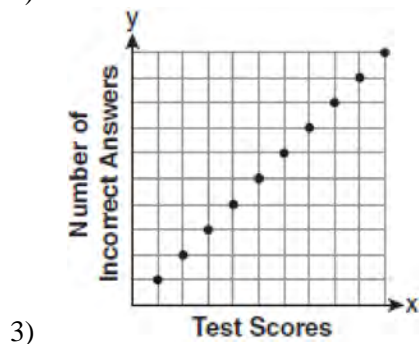
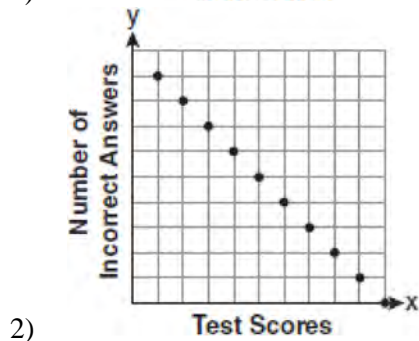
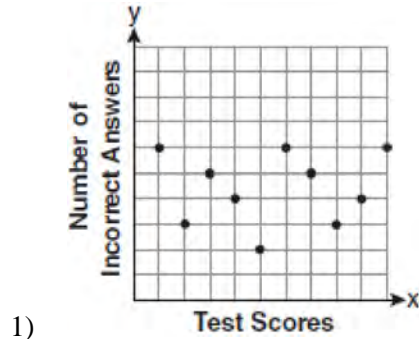

- 20 Which expression is equivalent to $3^3 \cdot 3^4$?
- 1) 9^{12}
 - 2) 9^7
 - 3) 3^{12}
 - 4) 3^7

- 21 Which point is on the line $4y - 2x = 0$?
- 1) $(-2, -1)$
 - 2) $(-2, 1)$
 - 3) $(-1, -2)$
 - 4) $(1, 2)$

- 22 If Ann correctly factors an expression that is the difference of two perfect squares, her factors could be
- 1) $(2x + y)(x - 2y)$
 - 2) $(2x + 3y)(2x - 3y)$
 - 3) $(x - 4)(x - 4)$
 - 4) $(2y - 5)(y - 5)$

- 23 Which ordered pair is in the solution set of the following system of linear inequalities?
- $$y < 2x + 2$$
- $$y \geq -x - 1$$

- 1) $(0, 3)$
- 2) $(2, 0)$
- 3) $(-1, 0)$
- 4) $(-1, -4)$

- 24 The expression $6\sqrt{50} + 6\sqrt{2}$ written in simplest radical form is
- 1) $6\sqrt{52}$
 - 2) $12\sqrt{52}$
 - 3) $17\sqrt{2}$
 - 4) $36\sqrt{2}$

- 25 What is the sum of $\frac{3x^2}{x-2}$ and $\frac{x^2}{x-2}$?
- 1) $\frac{3x^4}{(x-2)^2}$
 - 2) $\frac{3x^4}{x-2}$
 - 3) $\frac{4x^2}{(x-2)^2}$
 - 4) $\frac{4x^2}{x-2}$
- 26 Which equation represents a line parallel to the graph of $2x - 4y = 16$?
- 1) $y = \frac{1}{2}x - 5$
 - 2) $y = -\frac{1}{2}x + 4$
 - 3) $y = -2x + 6$
 - 4) $y = 2x + 8$
- 27 An example of an algebraic expression is
- 1) $\frac{2x+3}{7} = \frac{13}{x}$
 - 2) $(2x+1)(x-7)$
 - 3) $4x - 1 = 4$
 - 4) $x = 2$
- 28 What is the solution set of $\frac{x+2}{x-2} = \frac{-3}{x}$?
- 1) $\{-2, 3\}$
 - 2) $\{-3, -2\}$
 - 3) $\{-1, 6\}$
 - 4) $\{-6, 1\}$
- 29 How many square inches of wrapping paper are needed to entirely cover a box that is 2 inches by 3 inches by 4 inches?
- 1) 18
 - 2) 24
 - 3) 26
 - 4) 52
- 30 Which situation describes a correlation that is *not* a causal relationship?
- 1) the length of the edge of a cube and the volume of the cube
 - 2) the distance traveled and the time spent driving
 - 3) the age of a child and the number of siblings the child has
 - 4) the number of classes taught in a school and the number of teachers employed
- 31 Angela wants to purchase carpeting for her living room. The dimensions of her living room are 12 feet by 12 feet. If carpeting is sold by the square yard, determine how many square yards of carpeting she must purchase.
- 3 feet = 1 yard
9 square feet = 1 square yard
- 32 In right triangle ABC , $AB = 20$, $AC = 12$, $BC = 16$, and $m\angle C = 90$. Find, to the *nearest degree*, the measure of $\angle A$.

33 Jon is buying tickets for himself for two concerts. For the jazz concert, 4 tickets are available in the front row, and 32 tickets are available in the other rows. For the orchestra concert, 3 tickets are available in the front row, and 23 tickets are available in the other rows. Jon is randomly assigned one ticket for each concert. Determine the concert for which he is more likely to get a front-row ticket. Justify your answer.

34 Find the roots of the equation $x^2 - x = 6$ algebraically.

35 Ms. Mosher recorded the math test scores of six students in the table below.

Student	Student Score
Andrew	72
John	80
George	85
Amber	93
Betty	78
Roberto	80

Determine the mean of the student scores, to the *nearest tenth*. Determine the median of the student scores. Describe the effect on the mean and the median if Ms. Mosher adds 5 bonus points to each of the six students' scores.

36 Using his ruler, Howell measured the sides of a rectangular prism to be 5 cm by 8 cm by 4 cm. The actual measurements are 5.3 cm by 8.2 cm by 4.1 cm. Find Howell's relative error in calculating the volume of the prism, to the *nearest thousandth*.

37 A password consists of three digits, 0 through 9, followed by three letters from an alphabet having 26 letters. If repetition of digits is allowed, but repetition of letters is not allowed, determine the number of different passwords that can be made. If repetition is not allowed for digits or letters, determine how many fewer different passwords can be made.

38 Graph the solution set for the inequality $4x - 3y > 9$ on the set of axes below. Determine if the point $(1, -3)$ is in the solution set. Justify your answer.

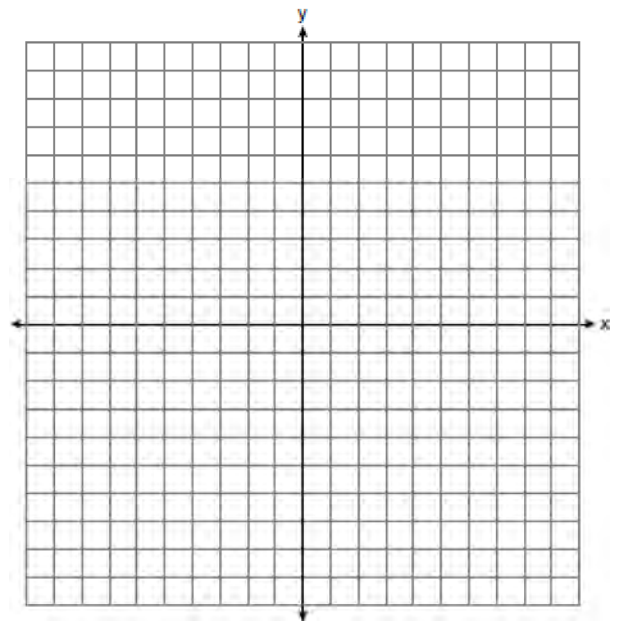

39 Find three consecutive positive even integers such that the product of the second and third integers is twenty more than ten times the first integer. [Only an algebraic solution can receive full credit.]

0610ia

- 1 Given: Set $U = \{S, O, P, H, I, A\}$

Set $B = \{A, I, O\}$

If set B is a subset of set U , what is the complement of set B ?

- 1) $\{O, P, S\}$
 - 2) $\{I, P, S\}$
 - 3) $\{A, H, P\}$
 - 4) $\{H, P, S\}$
- 2 How many different sandwiches consisting of one type of cheese, one condiment, and one bread choice can be prepared from five types of cheese, two condiments, and three bread choices?
- 1) 10
 - 2) 13
 - 3) 15
 - 4) 30

- 3 The sum of $4x^3 + 6x^2 + 2x - 3$ and

$3x^3 + 3x^2 - 5x - 5$ is

- 1) $7x^3 + 3x^2 - 3x - 8$
- 2) $7x^3 + 3x^2 + 7x + 2$
- 3) $7x^3 + 9x^2 - 3x - 8$
- 4) $7x^6 + 9x^4 - 3x^2 - 8$

- 4 What is the slope of the line that passes through the points $(3, 5)$ and $(-2, 2)$?

- 1) $\frac{1}{5}$
- 2) $\frac{3}{5}$
- 3) $\frac{5}{3}$
- 4) 5

- 5 What are the vertex and axis of symmetry of the parabola shown in the diagram below?

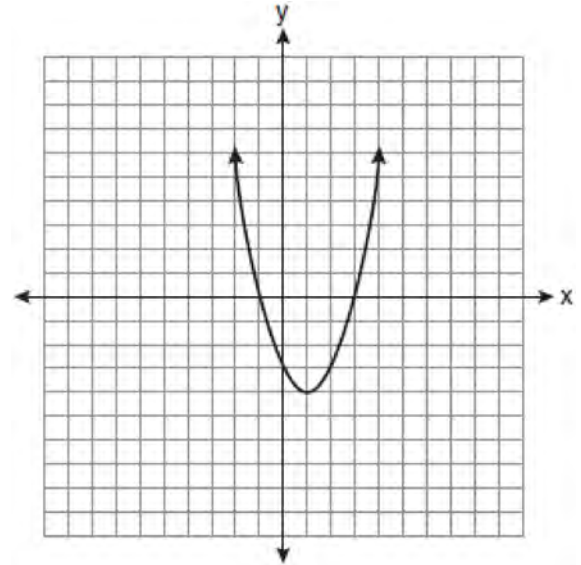

- 1) vertex: $(1, -4)$; axis of symmetry: $x = 1$
- 2) vertex: $(1, -4)$; axis of symmetry: $x = -4$
- 3) vertex: $(-4, 1)$; axis of symmetry: $x = 1$
- 4) vertex: $(-4, 1)$; axis of symmetry: $x = -4$

- 6 Three high school juniors, Reese, Matthew, and Chris, are running for student council president. A survey is taken a week before the election asking 40 students which candidate they will vote for in the election. The results are shown in the table below.

Candidate's Name	Number of Students Supporting Candidate
Reese	15
Matthew	13
Chris	12

Based on the table, what is the probability that a student will vote for Reese?

- 1) $\frac{1}{3}$
 - 2) $\frac{3}{5}$
 - 3) $\frac{3}{8}$
 - 4) $\frac{5}{8}$
- 7 Which linear equation represents a line containing the point (1,3)?
- 1) $x + 2y = 5$
 - 2) $x - 2y = 5$
 - 3) $2x + y = 5$
 - 4) $2x - y = 5$
- 8 The expression $\sqrt{72} - 3\sqrt{2}$ written in simplest radical form is
- 1) $5\sqrt{2}$
 - 2) $3\sqrt{6}$
 - 3) $3\sqrt{2}$
 - 4) $\sqrt{6}$

- 9 In $\triangle ABC$, the measure of $\angle B = 90^\circ$, $AC = 50$, $AB = 48$, and $BC = 14$. Which ratio represents the tangent of $\angle A$?

- 1) $\frac{14}{50}$
- 2) $\frac{14}{48}$
- 3) $\frac{48}{50}$
- 4) $\frac{48}{14}$

- 10 Which ordered pair is in the solution set of the system of linear inequalities graphed below?

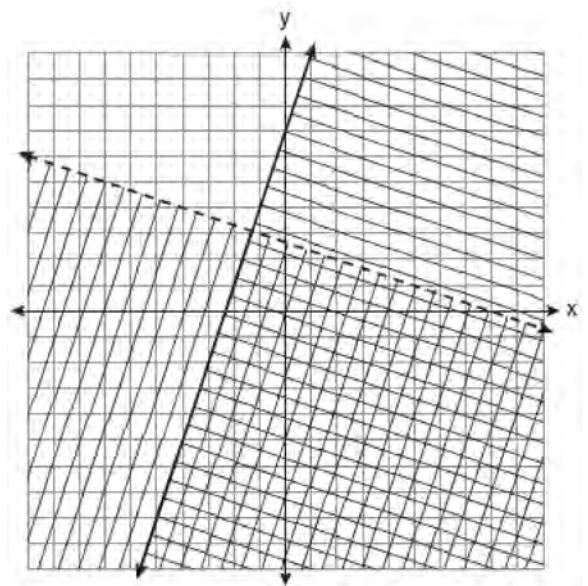

- 1) (1, -4)
- 2) (-5, 7)
- 3) (5, 3)
- 4) (-7, -2)

11 Which table does *not* show bivariate data?

1)

Height (inches)	Weight (pounds)
39	50
48	70
60	90

2)

Gallons	Miles Driven
15	300
20	400
25	500

3)

Quiz Average	Frequency
70	12
80	15
90	6

4)

Speed (mph)	Distance (miles)
40	80
50	120
55	150

12 What is the solution of the system of equations

$c + 3d = 8$ and $c = 4d - 6$?

- 1) $c = -14, d = -2$
- 2) $c = -2, d = 2$
- 3) $c = 2, d = 2$
- 4) $c = 14, d = -2$

13 Which graph represents a function?

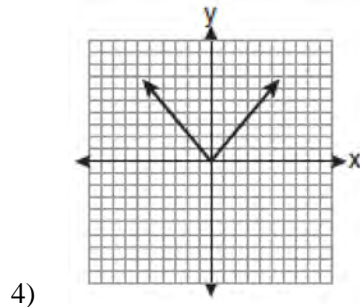
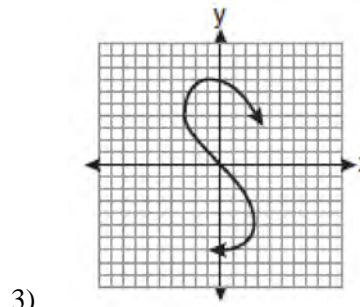
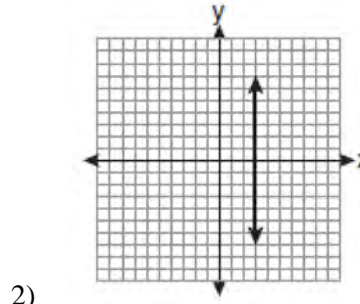
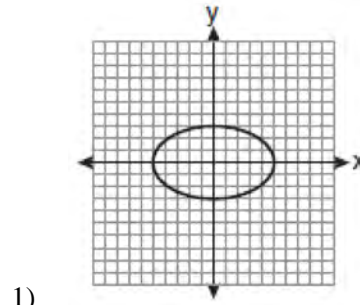

14 The algebraic expression $\frac{x-2}{x^2-9}$ is undefined when

- x is
- 1) 0
 - 2) 2
 - 3) 3
 - 4) 9

- 15 The graphs of the equations $y = 2x - 7$ and $y - kx = 7$ are parallel when k equals
- 1) -2
 - 2) 2
 - 3) -7
 - 4) 7

- 16 Which verbal expression is represented by $\frac{1}{2}(n - 3)$?
- 1) one-half n decreased by 3
 - 2) one-half n subtracted from 3
 - 3) the difference of one-half n and 3
 - 4) one-half the difference of n and 3

- 17 The freshman class held a canned food drive for 12 weeks. The results are summarized in the table below.

Canned Food Drive Results

Week	1	2	3	4	5	6	7	8	9	10	11	12
Number of Cans	20	35	32	45	58	46	28	23	31	79	65	62

Which number represents the second quartile of the number of cans of food collected?

- 1) 29.5
- 2) 30.5
- 3) 40
- 4) 60

- 18 Which expression represents $\frac{-14a^2c^8}{7a^3c^2}$ in simplest form?

- 1) $-2ac^4$
- 2) $-2ac^6$
- 3) $\frac{-2c^4}{a}$
- 4) $\frac{-2c^6}{a}$

- 19 Which value of x is the solution of $\frac{x}{3} + \frac{x+1}{2} = x$?
- 1) 1
 - 2) -1
 - 3) 3
 - 4) -3

- 20 When 36 is subtracted from the square of a number, the result is five times the number. What is the positive solution?
- 1) 9
 - 2) 6
 - 3) 3
 - 4) 4

- 21 Which interval notation represents the set of all numbers greater than or equal to 5 and less than 12?
- 1) $[5, 12)$
 - 2) $(5, 12]$
 - 3) $(5, 12)$
 - 4) $[5, 12]$

- 22 Four hundred licensed drivers participated in the math club's survey on driving habits. The table below shows the number of drivers surveyed in each age group.

Ages of People in Survey on Driving Habits

Age Group	Number of Drivers
16–25	150
26–35	129
36–45	33
46–55	57
56–65	31

Which statement best describes a conclusion based on the data in the table?

- 1) It may be biased because no one younger than 16 was surveyed.
 - 2) It would be fair because many different age groups were surveyed.
 - 3) It would be fair because the survey was conducted by the math club students.
 - 4) It may be biased because the majority of drivers surveyed were in the younger age intervals.
- 23 A formula used for calculating velocity is

$v = \frac{1}{2}at^2$. What is a expressed in terms of v and t ?

- 1) $a = \frac{2v}{t}$
- 2) $a = \frac{2v}{t^2}$
- 3) $a = \frac{v}{t}$
- 4) $a = \frac{v}{2t^2}$

- 24 What is the sum of $\frac{-x+7}{2x+4}$ and $\frac{2x+5}{2x+4}$?

- 1) $\frac{x+12}{2x+4}$
- 2) $\frac{3x+12}{2x+4}$
- 3) $\frac{x+12}{4x+8}$
- 4) $\frac{3x+12}{4x+8}$

- 25 Steve ran a distance of 150 meters in $1\frac{1}{2}$ minutes.

What is his speed in meters per hour?

- 1) 6
- 2) 60
- 3) 100
- 4) 6,000

- 26 How many different three-letter arrangements can be formed using the letters in the word *ABSOLUTE* if each letter is used only once?

- 1) 56
- 2) 112
- 3) 168
- 4) 336

- 27 Factored completely, the expression $3x^2 - 3x - 18$ is equivalent to

- 1) $3(x^2 - x - 6)$
- 2) $3(x - 3)(x + 2)$
- 3) $(3x - 9)(x + 2)$
- 4) $(3x + 6)(x - 3)$

- 28 Which quadrant will be completely shaded in the graph of the inequality $y \leq 2x$?

- 1) Quadrant I
- 2) Quadrant II
- 3) Quadrant III
- 4) Quadrant IV

- 29 A figure is made up of a rectangle and a semicircle as shown in the diagram below.

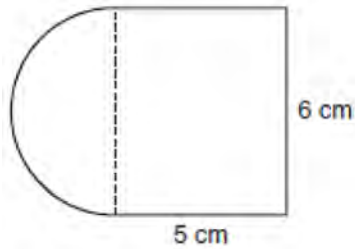

What is the area of the figure, to the *nearest tenth* of a square centimeter?

- 1) 39.4
 - 2) 44.1
 - 3) 48.8
 - 4) 58.3
- 30 The value, y , of a \$15,000 investment over x years is represented by the equation $y = 15000(1.2)^{\frac{x}{3}}$. What is the profit (interest) on a 6-year investment?
- 1) \$6,600
 - 2) \$10,799
 - 3) \$21,600
 - 4) \$25,799
- 31 Alexis calculates the surface area of a gift box as 600 square inches. The actual surface area of the gift box is 592 square inches. Find the relative error of Alexis' calculation expressed as a decimal to the *nearest thousandth*.
- 32 Perform the indicated operation: $-6(a - 7)$
State the name of the property used.

- 33 A communications company is building a 30-foot antenna to carry cell phone transmissions. As shown in the diagram below, a 50-foot wire from the top of the antenna to the ground is used to stabilize the antenna.

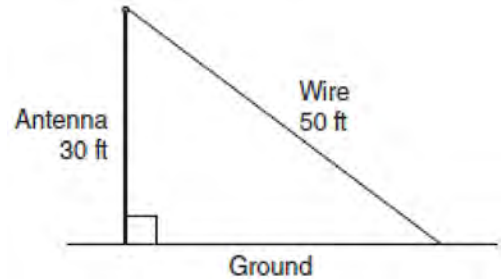

Find, to the *nearest degree*, the measure of the angle that the wire makes with the ground.

- 34 Given: $A = \{18, 6, -3, -12\}$
Determine all elements of set A that are in the solution of the inequality $\frac{2}{3}x + 3 < -2x - 7$.

- 35 Graph and label the following equations on the set of axes below.

$$y = |x|$$

$$y = \left| \frac{1}{2}x \right|$$

Explain how *decreasing* the coefficient of x affects the graph of the equation $y = |x|$.

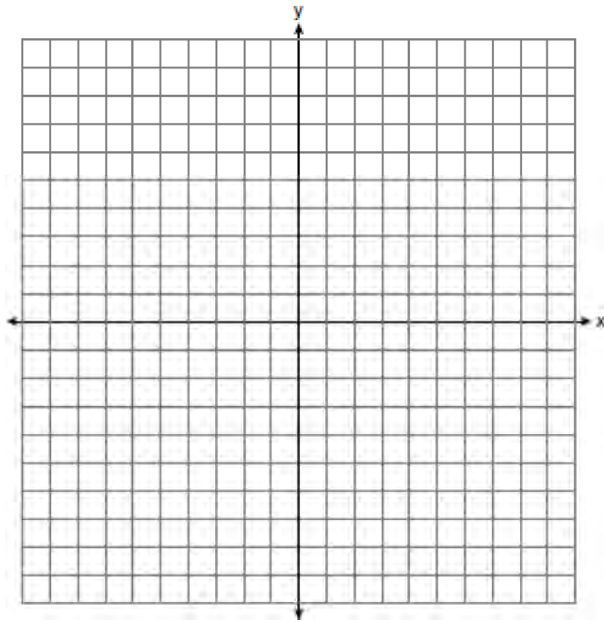

t (months)	P (profit, in thousands of dollars)
1	3.0
2	2.5
3	4.0
4	5.0
5	6.5
6	5.5
7	7.0
8	6.0
9	7.5
10	7.0
11	9.0
12	9.5

- 36 Megan and Bryce opened a new store called the Donut Pit. Their goal is to reach a profit of \$20,000 in their 18th month of business. The table and scatter plot below represent the profit, P , in thousands of dollars, that they made during the first 12 months.

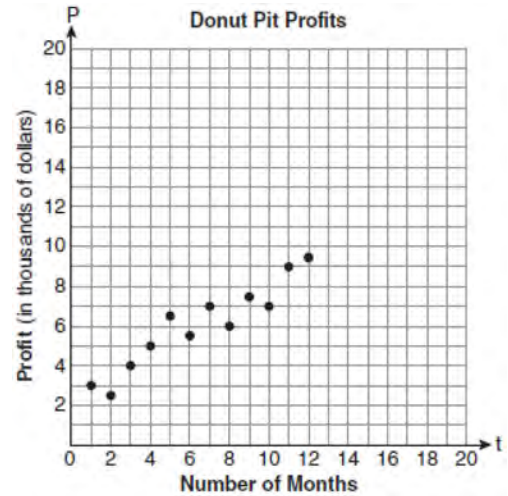

Draw a reasonable line of best fit. Using the line of best fit, predict whether Megan and Bryce will reach their goal in the 18th month of their business. Justify your answer.

- 37 Express in simplest form:

$$\frac{x^2 + 9x + 14}{x^2 - 49} \div \frac{3x + 6}{x^2 + x - 56}$$

- 38 The diagram below shows a cumulative frequency histogram of the students' test scores in Ms. Wedow's algebra class.

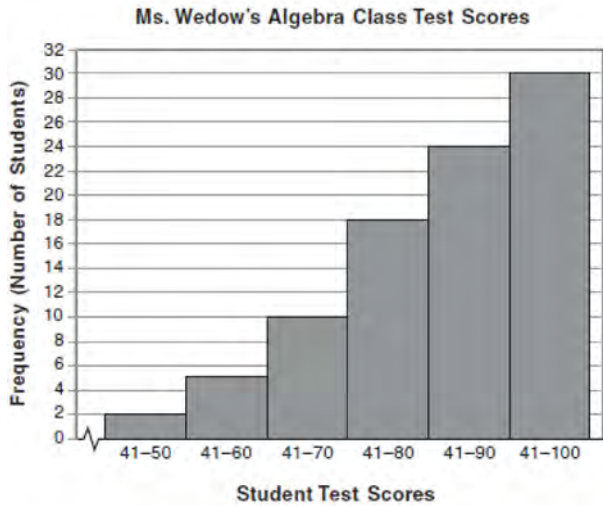

Determine the total number of students in the class. Determine how many students scored higher than 70. State which *ten-point interval* contains the median. State which *two ten-point intervals* contain the same frequency.

- 39 On the set of axes below, solve the following system of equations graphically for all values of x and y .

$$y = -x^2 - 4x + 12$$

$$y = -2x + 4$$

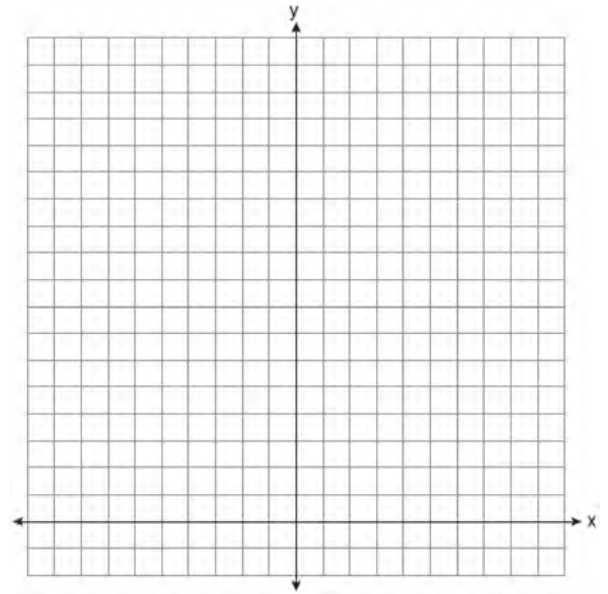

0810ia

- 1 The school store did a study comparing the cost of a sweatshirt with the number of sweatshirts sold. The price was changed several times and the numbers of sweatshirts sold were recorded. The data are shown in the table below.

Cost of Sweatshirt	\$10	\$25	\$15	\$20	\$5
Number Sold	9	6	15	11	14

Which scatter plot represents the data?

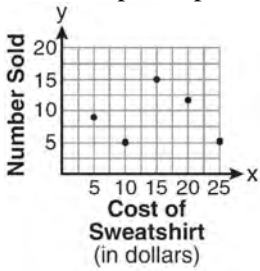

1)

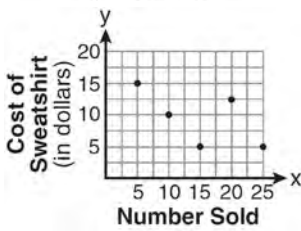

2)

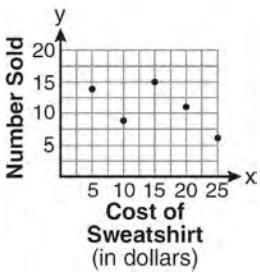

3)

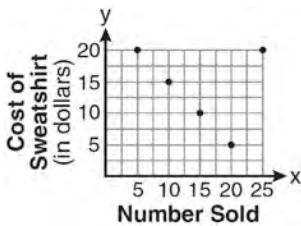

4)

- 2 What is the solution of $3(2m - 1) \leq 4m + 7$?

- 1) $m \leq 5$
- 2) $m \geq 5$
- 3) $m \leq 4$
- 4) $m \geq 4$

- 3 Which set represents the intersection of sets A, B, and C shown in the diagram below?

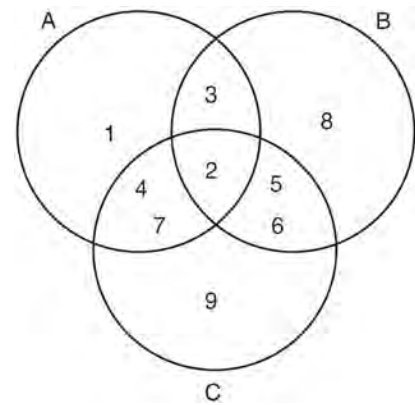

- 1) {3,4,5,6,7}
- 2) {2}
- 3) {2,3,4,5,6,7}
- 4) {1,2,3,4,5,6,7,8,9}

- 4 The end of a dog's leash is attached to the top of a 5-foot-tall fence post, as shown in the diagram below. The dog is 7 feet away from the base of the fence post.

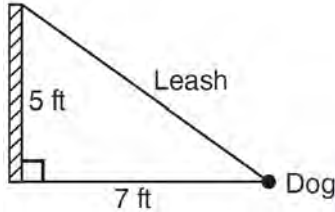

How long is the leash, to the *nearest tenth of a foot*?

- 1) 4.9
 - 2) 8.6
 - 3) 9.0
 - 4) 12.0
- 5 What is the slope of the line passing through the points *A* and *B*, as shown on the graph below?

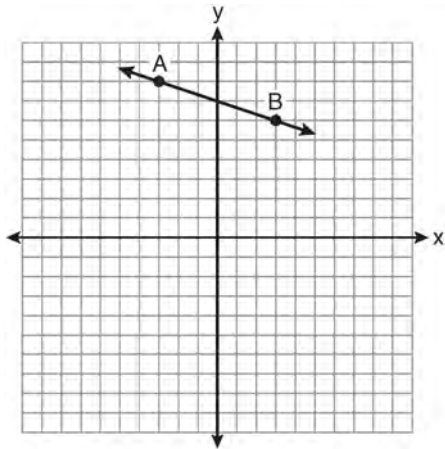

- 1) -3
- 2) $-\frac{1}{3}$
- 3) 3
- 4) $\frac{1}{3}$

- 6 The quotient of (9.2×10^6) and (2.3×10^2) expressed in scientific notation is
- 1) 4,000
 - 2) 40,000
 - 3) 4×10^3
 - 4) 4×10^4
- 7 In a recent town election, 1,860 people voted for either candidate *A* or candidate *B* for the position of supervisor. If candidate *A* received 55% of the votes, how many votes did candidate *B* receive?
- 1) 186
 - 2) 837
 - 3) 1,023
 - 4) 1,805

- 8 Which expression is equivalent to $121 - x^2$?
- 1) $(x - 11)(x - 11)$
 - 2) $(x + 11)(x - 11)$
 - 3) $(11 - x)(11 + x)$
 - 4) $(11 - x)(11 - x)$

- 9 Given: $U = \{1, 2, 3, 4, 5, 6, 7, 8\}$
 $B = \{2, 3, 5, 6\}$

Set *B* is a subset of set *U*. What is the complement of set *B*?

- 1) $\{ \}$
- 2) $\{2, 3, 5, 6\}$
- 3) $\{1, 4, 7, 8\}$
- 4) $\{1, 2, 3, 4, 5, 6, 7, 8\}$

- 10 Which graph can be used to find the solution of the following system of equations?

$$y = x^2 + 2x + 3$$

$$2y - 2x = 10$$

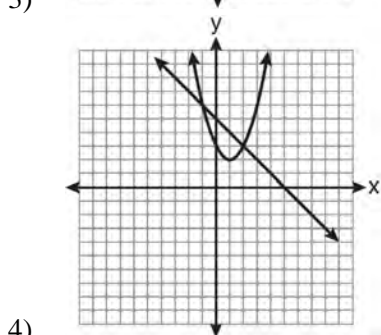
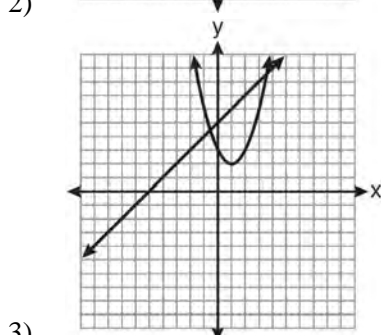
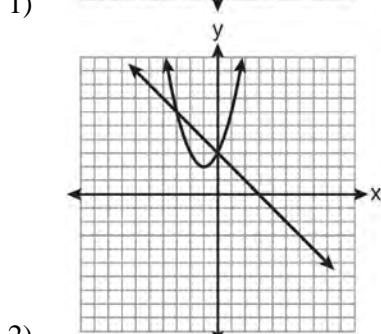
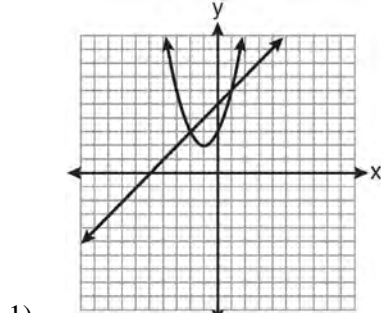

- 11 The width of a rectangle is 3 less than twice the length, x . If the area of the rectangle is 43 square feet, which equation can be used to find the length, in feet?

- 1) $2x(x - 3) = 43$
- 2) $x(3 - 2x) = 43$
- 3) $2x + 2(2x - 3) = 43$
- 4) $x(2x - 3) = 43$

- 12 Which value of x is the solution of $\frac{2x-3}{x-4} = \frac{2}{3}$?

- 1) $-\frac{1}{4}$
- 2) $\frac{1}{4}$
- 3) -4
- 4) 4

- 13 What is the perimeter of a regular pentagon with a side whose length is $x + 4$?

- 1) $x^2 + 16$
- 2) $4x + 16$
- 3) $5x + 4$
- 4) $5x + 20$

- 14 Which equation represents a line parallel to the y -axis?

- 1) $x = y$
- 2) $x = 4$
- 3) $y = 4$
- 4) $y = x + 4$

- 15 The diagram below shows the graph of $y = -x^2 - c$.

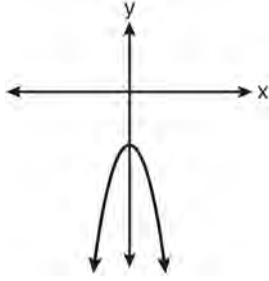

Which diagram shows the graph of $y = x^2 - c$?

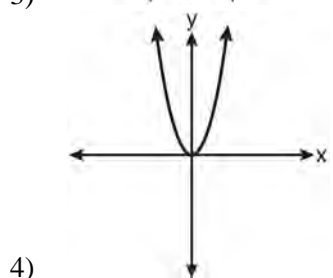
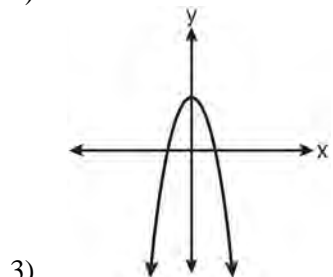
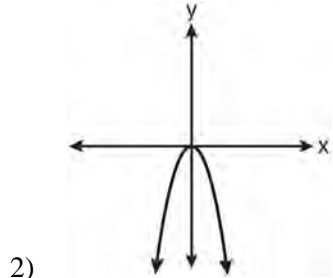
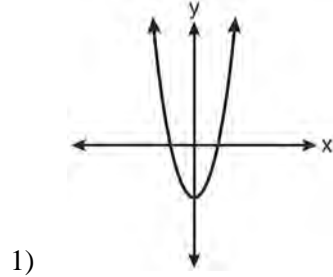

16 Which point lies on the line whose equation is $2x - 3y = 9$?

- 1) $(-1, -3)$
- 2) $(-1, 3)$
- 3) $(0, 3)$
- 4) $(0, -3)$

17 Which phrase best describes the relationship between the number of miles driven and the amount of gasoline used?

- 1) causal, but not correlated
- 2) correlated, but not causal
- 3) both correlated and causal
- 4) neither correlated nor causal

18 The height, y , of a ball tossed into the air can be represented by the equation $y = -x^2 + 10x + 3$, where x is the elapsed time. What is the equation of the axis of symmetry of this parabola?

- 1) $y = 5$
- 2) $y = -5$
- 3) $x = 5$
- 4) $x = -5$

- 19 In the diagram below, $MATH$ is a rectangle, $GB = 4.6$, $MH = 6$, and $HT = 15$.

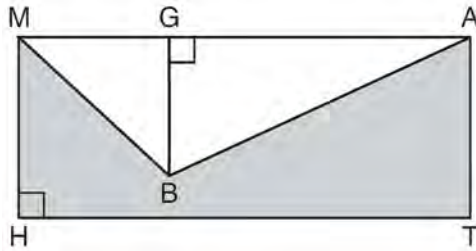

What is the area of polygon $MBATH$?

- 1) 34.5
 2) 55.5
 3) 90.0
 4) 124.5
- 20 This year, John played in 10 baseball games. In these games he had hit the ball 2, 3, 0, 1, 3, 2, 4, 0, 2, and 3 times. In the first 10 games he plays next year, John wants to increase his average (mean) hits per game by 0.5. What is the total number of hits John needs over the first 10 games next year to achieve his goal?
- 1) 5
 2) 2
 3) 20
 4) 25
- 21 What is the value of the y -coordinate of the solution to the system of equations $2x + y = 8$ and $x - 3y = -3$?
- 1) -2
 2) 2
 3) 3
 4) -3

- 22 Which set-builder notation describes $\{-3, -2, -1, 0, 1, 2\}$?
- 1) $\{x \mid -3 \leq x < 2, \text{ where } x \text{ is an integer}\}$
 2) $\{x \mid -3 < x \leq 2, \text{ where } x \text{ is an integer}\}$
 3) $\{x \mid -3 < x < 2, \text{ where } x \text{ is an integer}\}$
 4) $\{x \mid -3 \leq x \leq 2, \text{ where } x \text{ is an integer}\}$

- 23 Corinne calculated the area of a paper plate to be 50.27 square inches. If the actual area of the plate is 55.42 square inches, what is the relative error in calculating the area, to the nearest thousandth?
- 1) 0.092
 2) 0.093
 3) 0.102
 4) 0.103

- 24 The probability that it will snow on Sunday is $\frac{3}{5}$. The probability that it will snow on both Sunday and Monday is $\frac{3}{10}$. What is the probability that it will snow on Monday, if it snowed on Sunday?
- 1) $\frac{9}{50}$
 2) 2
 3) $\frac{1}{2}$
 4) $\frac{9}{10}$

25 Which graph represents an exponential equation?

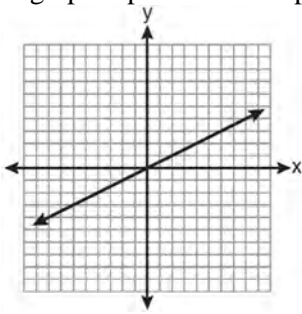

1)

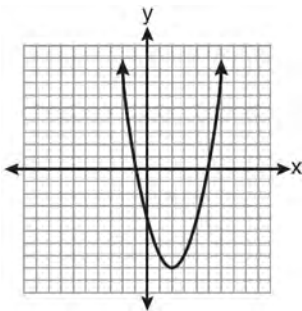

2)

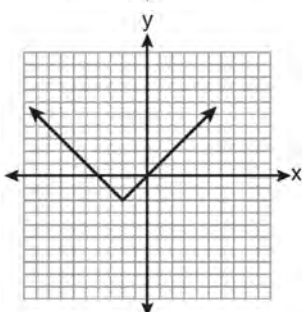

3)

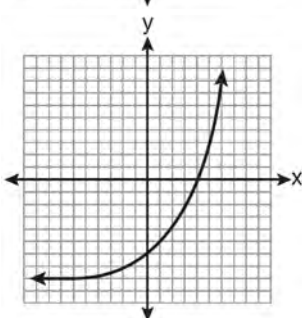

4)

26 Right triangle ABC has legs of 8 and 15 and a hypotenuse of 17, as shown in the diagram below.

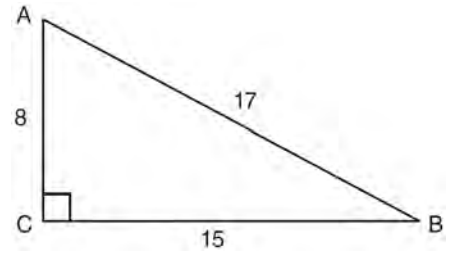

The value of the tangent of $\angle B$ is

- 1) 0.4706
- 2) 0.5333
- 3) 0.8824
- 4) 1.8750

27 What is $\frac{2+x}{5x} - \frac{x-2}{5x}$ expressed in simplest form?

- 1) 0
- 2) $\frac{2}{5}$
- 3) $\frac{4}{5x}$
- 4) $\frac{2x+4}{5x}$

28 How many different four-letter arrangements are possible with the letters G, A, R, D, E, N if each letter may be used only once?

- 1) 15
- 2) 24
- 3) 360
- 4) 720

29 What is an equation of the line that passes through the points (1,3) and (8,5)?

1) $y + 1 = \frac{2}{7}(x + 3)$

2) $y - 5 = \frac{2}{7}(x - 8)$

3) $y - 1 = \frac{2}{7}(x + 3)$

4) $y + 5 = \frac{2}{7}(x - 8)$

30 An example of an algebraic expression is

1) $x + 2$

2) $y = x + 2$

3) $y < x + 2$

4) $y = x^2 + 2x$

31 Express in simplest form: $\frac{45a^4b^3 - 90a^3b}{15a^2b}$

32 Joseph typed a 1,200-word essay in 25 minutes. At this rate, determine how many words he can type in 45 minutes.

33 Express $-3\sqrt{48}$ in simplest radical form.

34 The number of songs fifteen students have on their MP3 players is:

120,124, 132, 145,200,255,260,292,
308,314,342,407,421,435,452

State the values of the minimum, 1st quartile, median, 3rd quartile, and maximum. Using these values, construct a box-and-whisker plot using an appropriate scale on the line below.

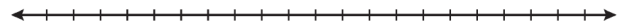

35 Find the volume, in cubic centimeters, *and* the surface area, in square centimeters, of the rectangular prism shown below.

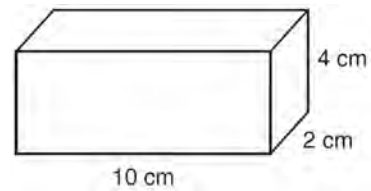

36 Find the roots of the equation $x^2 = 30 - 13x$ algebraically.

- 37 On the set of axes below, solve the following system of inequalities graphically.

$$y < 2x + 1$$

$$y \geq -\frac{1}{3}x + 4$$

State the coordinates of a point in the solution set.

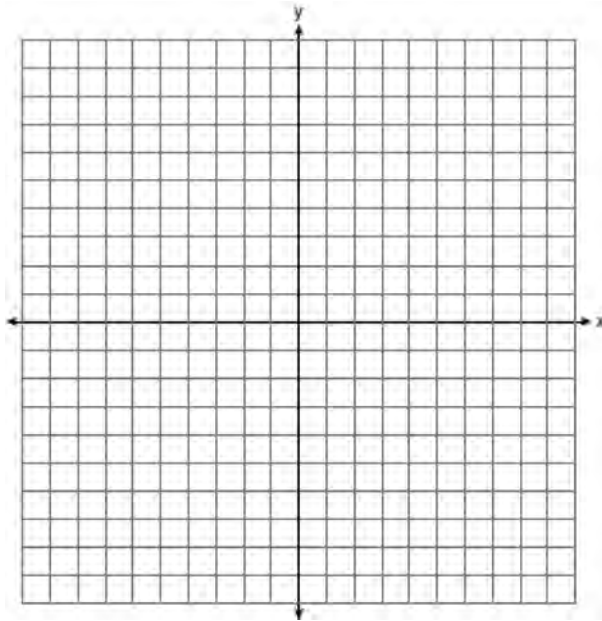

- 38 Each of the hats shown below has colored marbles placed inside. Hat A contains five green marbles and four red marbles. Hat B contains six blue marbles and five red marbles. Hat C contains five green marbles and five blue marbles.



If a student were to randomly pick one marble from each of these three hats, determine from which hat the student would most likely pick a green marble. Justify your answer. Determine the fewest number of marbles, if any, and the color of these marbles that could be added to *each* hat so that the probability of picking a green marble will be one-half in each of the three hats.

- 39 A hot-air balloon is tied to the ground with two taut (straight) ropes, as shown in the diagram below. One rope is directly under the balloon and makes a right angle with the ground. The other rope forms an angle of 50° with the ground.

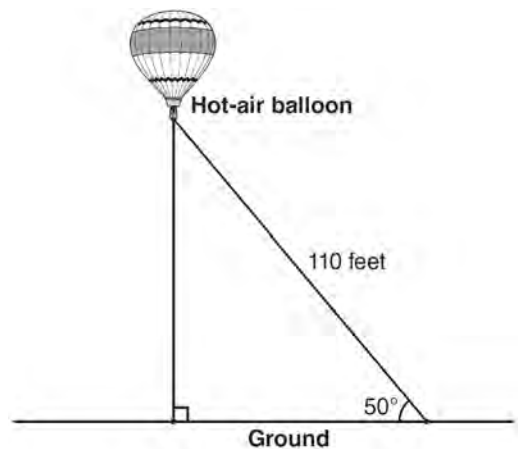

Determine the height, to the *nearest foot*, of the balloon directly above the ground. Determine the distance, to the *nearest foot*, on the ground between the two ropes.

0111ia

1 Given: $X = \{1, 2, 3, 4\}$

$Y = \{2, 3, 4, 5\}$

$Z = \{3, 4, 5, 6\}$

What is the intersection of sets X , Y , and Z ?

- 1) $\{3, 4\}$
- 2) $\{2, 3, 4\}$
- 3) $\{3, 4, 5\}$
- 4) $\{1, 2, 3, 4, 5, 6\}$

2 Which graph could be used to find the solution of the system of equations $y = 2x + 6$ and

$y = x^2 + 4x + 3$?

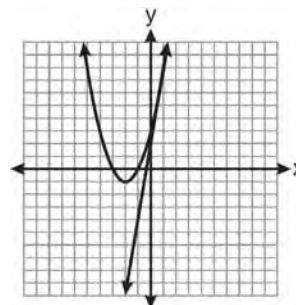

1)

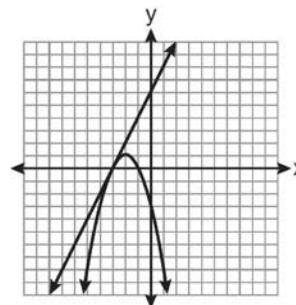

2)

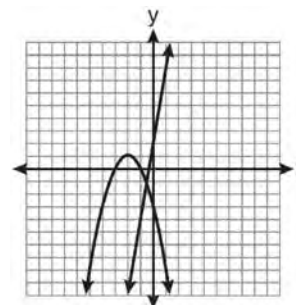

3)

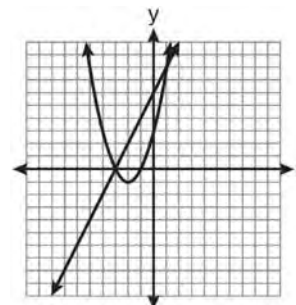

4)

- 3 What is the relationship between the independent and dependent variables in the scatter plot shown below?

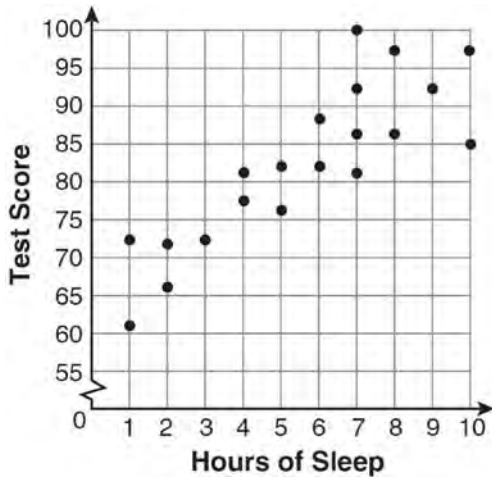

- 1) undefined correlation
 2) negative correlation
 3) positive correlation
 4) no correlation
- 4 Tim ate four more cookies than Alice. Bob ate twice as many cookies as Tim. If x represents the number of cookies Alice ate, which expression represents the number of cookies Bob ate?
- 1) $2 + (x + 4)$
 2) $2x + 4$
 3) $2(x + 4)$
 4) $4(x + 2)$

- 5 Which relation is a function?

- 1) $\left\{ \left(\frac{3}{4}, 0 \right), (0, 1), \left(\frac{3}{4}, 2 \right) \right\}$
 2) $\left\{ (-2, 2), \left(-\frac{1}{2}, 1 \right), (-2, 4) \right\}$
 3) $\{(-1, 4), (0, 5), (0, 4)\}$
 4) $\{(2, 1), (4, 3), (6, 5)\}$

- 6 What is the value of x in the equation $2(x - 4) = 4(2x + 1)$?

- 1) -2
 2) 2
 3) $-\frac{1}{2}$
 4) $\frac{1}{2}$

- 7 The rectangle shown below has a diagonal of 18.4 cm and a width of 7 cm.

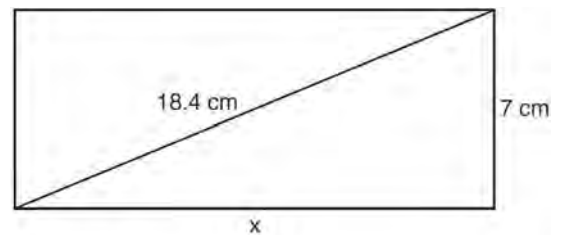

To the *nearest centimeter*, what is the length, x , of the rectangle?

- 1) 11
 2) 17
 3) 20
 4) 25

- 8 When $a^3 - 4a$ is factored completely, the result is
- 1) $(a - 2)(a + 2)$
 - 2) $a(a - 2)(a + 2)$
 - 3) $a^2(a - 4)$
 - 4) $a(a - 2)^2$

- 9 Which ratio represents $\sin x$ in the right triangle shown below?

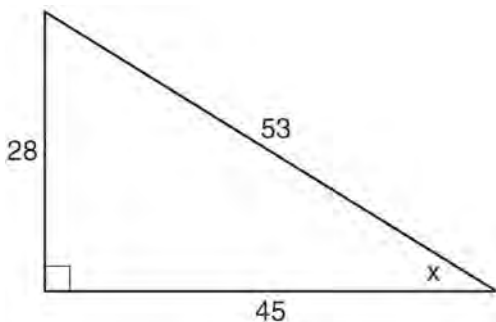

- 1) $\frac{28}{53}$
 - 2) $\frac{28}{45}$
 - 3) $\frac{45}{53}$
 - 4) $\frac{53}{28}$
- 10 What is the value of the expression $(a^3 + b^0)^2$ when $a = -2$ and $b = 4$?
- 1) 64
 - 2) 49
 - 3) -49
 - 4) -64

- 11 A student correctly graphed the parabola shown below to solve a given quadratic equation.

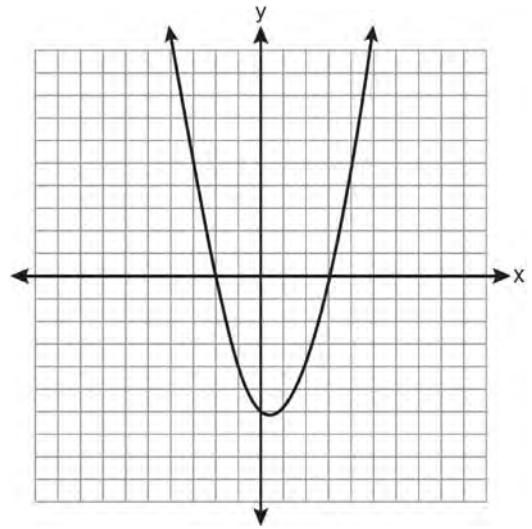

What are the roots of the quadratic equation associated with this graph?

- 1) -6 and 3
 - 2) -6 and 0
 - 3) -3 and 2
 - 4) -2 and 3
- 12 Which value of x is the solution of the equation $\frac{2}{3}x + \frac{1}{2} = \frac{5}{6}$?
- 1) $\frac{1}{2}$
 - 2) 2
 - 3) $\frac{2}{3}$
 - 4) $\frac{3}{2}$

- 13 What is the range of the data represented in the box-and-whisker plot shown below?

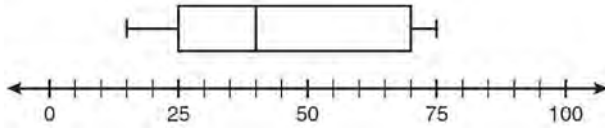

- 1) 40
 - 2) 45
 - 3) 60
 - 4) 100
- 14 Which equation illustrates the associative property?

- 1) $x + y + z = x + y + z$
- 2) $x(y + z) = xy + xz$
- 3) $x + y + z = z + y + x$
- 4) $(x + y) + z = x + (y + z)$

- 15 Josh and Mae work at a concession stand. They each earn \$8 per hour. Josh worked three hours more than Mae. If Josh and Mae earned a total of \$120, how many hours did Josh work?

- 1) 6
- 2) 9
- 3) 12
- 4) 15

- 16 Which data set describes a situation that could be classified as quantitative?

- 1) the phone numbers in a telephone book
- 2) the addresses for students at Hopkins High School
- 3) the zip codes of residents in the city of Buffalo, New York
- 4) the time it takes each of Mr. Harper's students to complete a test

- 17 Which is the graph of $y = |x| + 2$?

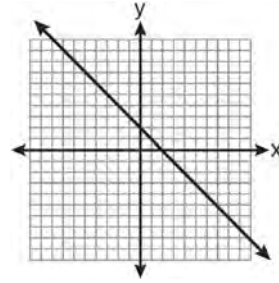

1)

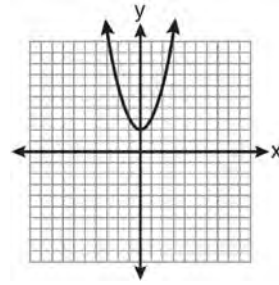

2)

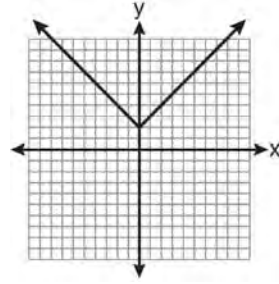

3)

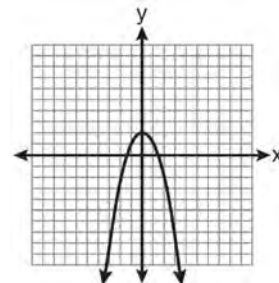

4)

- 18 Sam's grades on eleven chemistry tests were 90, 85, 76, 63, 94, 89, 81, 76, 78, 69, and 97. Which statement is true about the measures of central tendency?

- 1) mean > mode
- 2) mean < median
- 3) mode > median
- 4) median = mean

- 19 Which interval notation represents the set of all real numbers greater than 2 and less than or equal to 20?
- 1) $(2, 20)$
 - 2) $(2, 20]$
 - 3) $[2, 20)$
 - 4) $[2, 20]$

20 What is the sum of $\frac{3}{2x}$ and $\frac{7}{4x}$?

- 1) $\frac{21}{8x^2}$
- 2) $\frac{13}{4x}$
- 3) $\frac{10}{6x}$
- 4) $\frac{13}{8x}$

21 What is $3\sqrt{2} + \sqrt{8}$ expressed in simplest radical form?

- 1) $3\sqrt{10}$
- 2) $3\sqrt{16}$
- 3) $5\sqrt{2}$
- 4) $7\sqrt{2}$

22 What is the slope of the line whose equation is $3x - 7y = 9$?

- 1) $-\frac{3}{7}$
- 2) $\frac{3}{7}$
- 3) $-\frac{7}{3}$
- 4) $\frac{7}{3}$

- 23 The figure shown below is composed of two rectangles and a quarter circle.

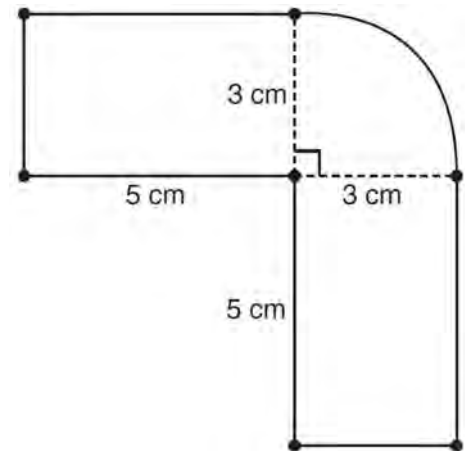

What is the area of this figure, to the nearest square centimeter?

- 1) 33
- 2) 37
- 3) 44
- 4) 58

24 The expression $\frac{(10w^3)^2}{5w}$ is equivalent to

- 1) $2w^5$
- 2) $2w^8$
- 3) $20w^5$
- 4) $20w^8$

25 If $\frac{ey}{n} + k = t$, what is y in terms of e , n , k , and t ?

1) $y = \frac{tn + k}{e}$

2) $y = \frac{tn - k}{e}$

3) $y = \frac{n(t + k)}{e}$

4) $y = \frac{n(t - k)}{e}$

26 What is the result when $2x^2 + 3xy - 6$ is subtracted from $x^2 - 7xy + 2$?

1) $-x^2 - 10xy + 8$

2) $x^2 + 10xy - 8$

3) $-x^2 - 4xy - 4$

4) $x^2 - 4xy - 4$

27 What is an equation of the axis of symmetry of the parabola represented by $y = -x^2 + 6x - 4$?

1) $x = 3$

2) $y = 3$

3) $x = 6$

4) $y = 6$

28 Which equation has roots of -3 and 5 ?

1) $x^2 + 2x - 15 = 0$

2) $x^2 - 2x - 15 = 0$

3) $x^2 + 2x + 15 = 0$

4) $x^2 - 2x + 15 = 0$

29 A spinner that is equally divided into eight numbered sectors is spun 20 times. The table below shows the number of times the arrow landed in each numbered sector.

Spinner Sector	Number of Times
1	2
2	3
3	2
4	3
5	4
6	2
7	3
8	1

Based on the table, what is the empirical probability that the spinner will land on a prime number on the next spin?

1) $\frac{9}{20}$

2) $\frac{11}{20}$

3) $\frac{12}{20}$

4) $\frac{14}{20}$

30 Which expression represents $\frac{x^2 - x - 6}{x^2 - 5x + 6}$ in simplest form?

1) $\frac{x + 2}{x - 2}$

2) $\frac{-x - 6}{-5x + 6}$

3) $\frac{1}{5}$

4) -1

- 31 Roberta needs ribbon for a craft project. The ribbon sells for \$3.75 per yard. Find the cost, in dollars, for 48 inches of the ribbon.

- 32 The square dart board shown below has a side that measures 40 inches. The shaded portion in the center is a square whose side is 15 inches. A dart thrown at the board is equally likely to land on any point on the dartboard.

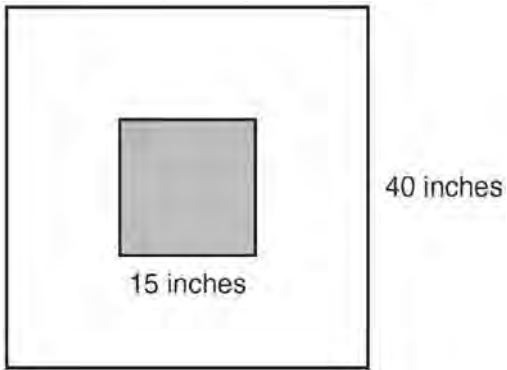

Find the probability that a dart hitting the board will *not* land in the shaded area.

- 33 As shown in the diagram below, a ladder 5 feet long leans against a wall and makes an angle of 65° with the ground. Find, to the *nearest tenth of a foot*, the distance from the wall to the base of the ladder.

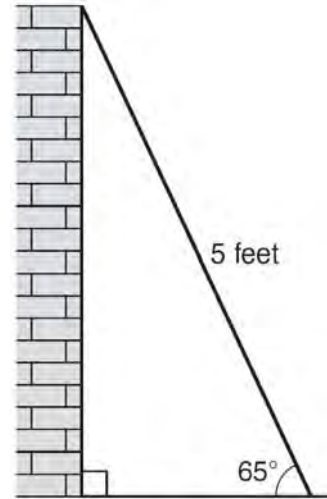

- 34 A line having a slope of $\frac{3}{4}$ passes through the point $(-8, 4)$. Write the equation of this line in slope-intercept form.

- 35 The test scores for 18 students in Ms. Mosher’s class are listed below:

86, 81, 79, 71, 58, 87, 52, 71, 87,

87, 93, 64, 94, 81, 76, 98, 94, 68

Complete the frequency table below.

Interval	Tally	Frequency
51–60		
61–70		
71–80		
81–90		
91–100		

Draw and label a frequency histogram on the grid below.

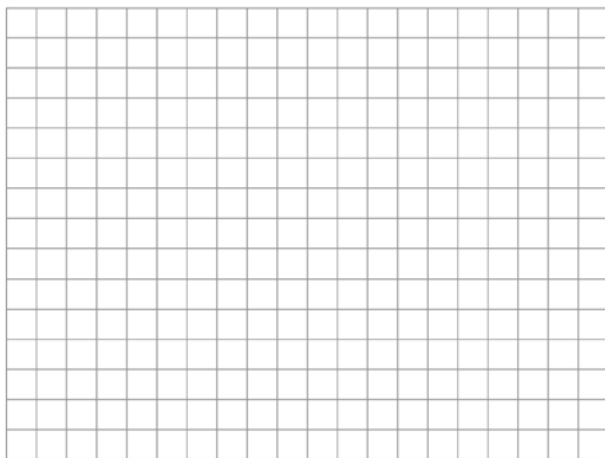

- 36 Solve algebraically for x : $\frac{x+2}{6} = \frac{3}{x-1}$

- 37 An oil company distributes oil in a metal can shaped like a cylinder that has an actual radius of 5.1 cm and a height of 15.1 cm. A worker incorrectly measured the radius as 5 cm and the height as 15 cm. Determine the relative error in calculating the surface area, to the *nearest thousandth*.

- 38 The Booster Club raised \$30,000 for a sports fund. No more money will be placed into the fund. Each year the fund will decrease by 5%. Determine the amount of money, to the *nearest cent*, that will be left in the sports fund after 4 years.

- 39 Graph the following systems of inequalities on the set of axes shown below and label the solution set S :

$$y > -x + 2$$

$$y \leq \frac{2}{3}x + 5$$

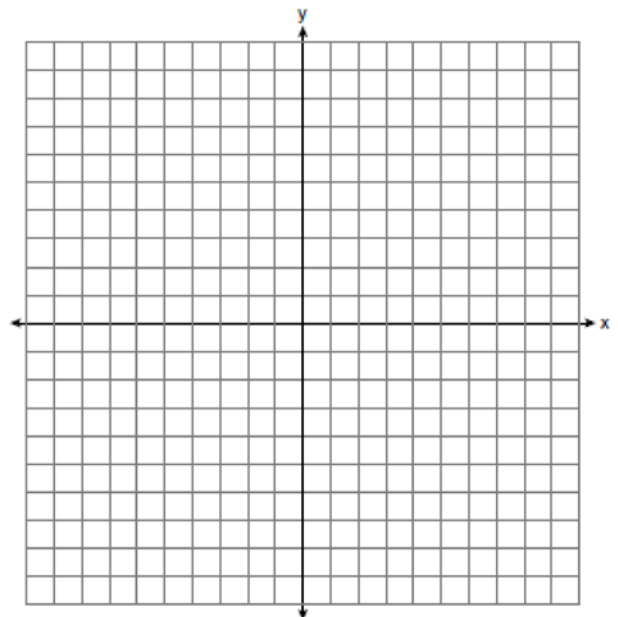

0611ia

1 The expression $x^2 - 36y^2$ is equivalent to

- 1) $(x - 6y)(x - 6y)$
- 2) $(x - 18y)(x - 18y)$
- 3) $(x + 6y)(x - 6y)$
- 4) $(x + 18y)(x - 18y)$

2 The legs of an isosceles right triangle each measure 10 inches. What is the length of the hypotenuse of this triangle, to the *nearest tenth of an inch*?

- 1) 6.3
- 2) 7.1
- 3) 14.1
- 4) 17.1

3 The expression $\frac{12w^9y^3}{-3w^3y^3}$ is equivalent to

- 1) $-4w^6$
- 2) $-4w^3y$
- 3) $9w^6$
- 4) $9w^3y$

4 The spinner shown in the diagram below is divided into six equal sections.

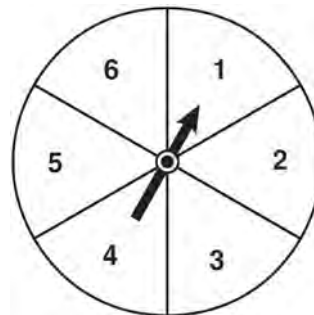

Which outcome is *least* likely to occur on a single spin?

- 1) an odd number
- 2) a prime number
- 3) a perfect square
- 4) a number divisible by 2

5 What are the factors of the expression $x^2 + x - 20$?

- 1) $(x + 5)$ and $(x + 4)$
- 2) $(x + 5)$ and $(x - 4)$
- 3) $(x - 5)$ and $(x + 4)$
- 4) $(x - 5)$ and $(x - 4)$

6 What is $3\sqrt{250}$ expressed in simplest radical form?

- 1) $5\sqrt{10}$
- 2) $8\sqrt{10}$
- 3) $15\sqrt{10}$
- 4) $75\sqrt{10}$

- 7 A survey is being conducted to determine which school board candidate would best serve the Yonkers community. Which group, when randomly surveyed, would likely produce the most bias?
- 1) 15 employees of the Yonkers school district
 - 2) 25 people driving past Yonkers High School
 - 3) 75 people who enter a Yonkers grocery store
 - 4) 100 people who visit the local Yonkers shopping mall

- 8 An 8-foot rope is tied from the top of a pole to a stake in the ground, as shown in the diagram below.

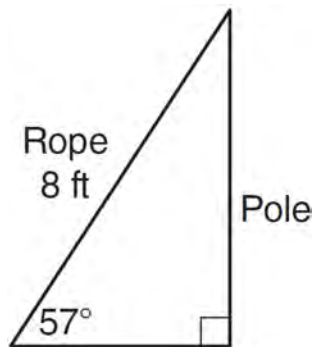

If the rope forms a 57° angle with the ground, what is the height of the pole, to the *nearest tenth of a foot*?

- 1) 4.4
 - 2) 6.7
 - 3) 9.5
 - 4) 12.3
- 9 How many different ways can five books be arranged on a shelf?
- 1) 5
 - 2) 15
 - 3) 25
 - 4) 120

- 10 What is the slope of the line passing through the points $(-2,4)$ and $(3,6)$?

- 1) $-\frac{5}{2}$
- 2) $-\frac{2}{5}$
- 3) $\frac{2}{5}$
- 4) $\frac{5}{2}$

- 11 Which type of function is represented by the graph shown below?

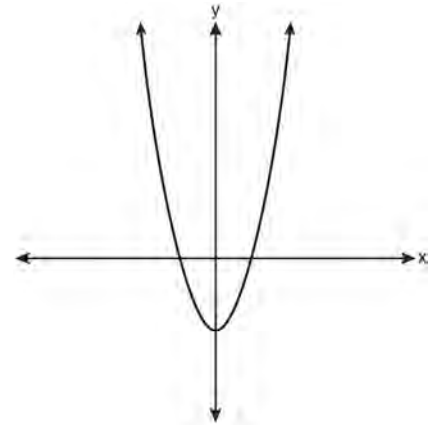

- 1) absolute value
 - 2) exponential
 - 3) linear
 - 4) quadratic
- 12 Which equation represents a line parallel to the y-axis?
- 1) $y = x$
 - 2) $y = 3$
 - 3) $x = -y$
 - 4) $x = -4$

- 13 Melissa graphed the equation $y = x^2$ and Dave graphed the equation $y = -3x^2$ on the same coordinate grid. What is the relationship between the graphs that Melissa and Dave drew?
- 1) Dave's graph is wider and opens in the opposite direction from Melissa's graph.
 - 2) Dave's graph is narrower and opens in the opposite direction from Melissa's graph.
 - 3) Dave's graph is wider and is three units below Melissa's graph.
 - 4) Dave's graph is narrower and is three units to the left of Melissa's graph.

- 14 In right triangle ABC shown below, $AB = 18.3$ and $BC = 11.2$.

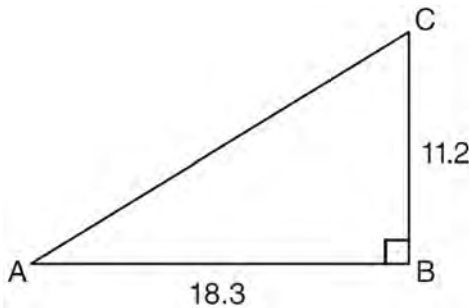

What is the measure of $\angle A$, to the nearest tenth of a degree?

- 1) 31.5
 - 2) 37.7
 - 3) 52.3
 - 4) 58.5
- 15 The maximum height and speed of various roller coasters in North America are shown in the table below.

Maximum Speed, in mph, (x)	45	50	54	60	65	70
Maximum Height, in feet, (y)	63	80	105	118	141	107

Which graph represents a correct scatter plot of the data?

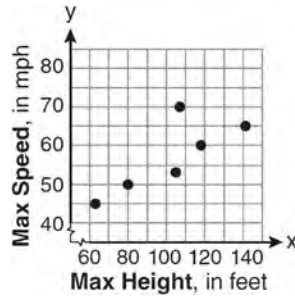

1)

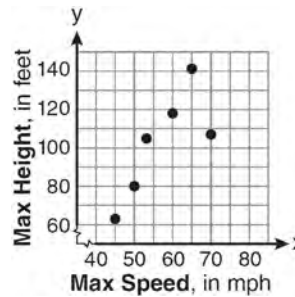

2)

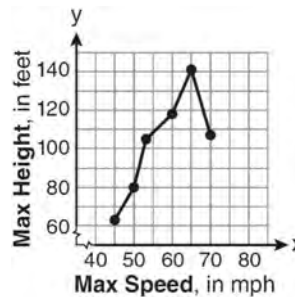

3)

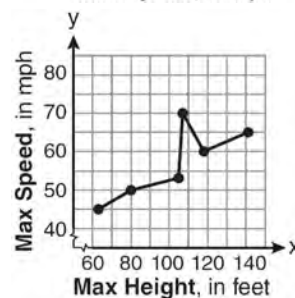

4)

- 16 Which set of ordered pairs represents a function?
- 1) $\{(0,4), (2,4), (2,5)\}$
 - 2) $\{(6,0), (5,0), (4,0)\}$
 - 3) $\{(4,1), (6,2), (6,3), (5,0)\}$
 - 4) $\{(0,4), (1,4), (0,5), (1,5)\}$

- 17 A hiker walked 12.8 miles from 9:00 a.m. to noon. He walked an additional 17.2 miles from 1:00 p.m. to 6:00 p.m. What is his average rate for the entire walk, in miles per hour?
- 1) 3.75
 - 2) 3.86
 - 3) 4.27
 - 4) 7.71
- 18 Which ordered pair is a solution to the system of equations $y = x + 3$ and $y = x^2 - x$?
- 1) (6,9)
 - 2) (3,6)
 - 3) (3,-1)
 - 4) (2,5)
- 19 Which verbal expression can be represented by $2(x - 5)$?
- 1) 5 less than 2 times x
 - 2) 2 multiplied by x less than 5
 - 3) twice the difference of x and 5
 - 4) the product of 2 and x , decreased by 5
- 20 The dimensions of a rectangle are measured to be 12.2 inches by 11.8 inches. The actual dimensions are 12.3 inches by 11.9 inches. What is the relative error, to the nearest *ten-thousandth*, in calculating the area of the rectangle?
- 1) 0.0168
 - 2) 0.0167
 - 3) 0.0165
 - 4) 0.0164
- 21 An example of an algebraic expression is
- 1) $y = mx + b$
 - 2) $3x + 4y - 7$
 - 3) $2x + 3y \leq 18$
 - 4) $(x + y)(x - y) = 25$
- 22 A study showed that a decrease in the cost of carrots led to an increase in the number of carrots sold. Which statement best describes this relationship?
- 1) positive correlation and a causal relationship
 - 2) negative correlation and a causal relationship
 - 3) positive correlation and not a causal relationship
 - 4) negative correlation and not a causal relationship
- 23 Given: $A = \{3, 6, 9, 12, 15\}$
 $B = \{2, 4, 6, 8, 10, 12\}$
What is the union of sets A and B ?
- 1) {6}
 - 2) {6, 12}
 - 3) {2, 3, 4, 8, 9, 10, 15}
 - 4) {2, 3, 4, 6, 8, 9, 10, 12, 15}
- 24 The value of a car purchased for \$20,000 decreases at a rate of 12% per year. What will be the value of the car after 3 years?
- 1) \$12,800.00
 - 2) \$13,629.44
 - 3) \$17,600.00
 - 4) \$28,098.56
- 25 For which set of values of x is the algebraic expression $\frac{x^2 - 16}{x^2 - 4x - 12}$ undefined?
- 1) {-6, 2}
 - 2) {-4, 3}
 - 3) {-4, 4}
 - 4) {-2, 6}

- 26 Michael is 25 years younger than his father. The sum of their ages is 53. What is Michael's age?
- 1) 14
 - 2) 25
 - 3) 28
 - 4) 39

- 27 What is the product of (6×10^3) , (4.6×10^5) , and (2×10^{-2}) expressed in scientific notation?
- 1) 55.2×10^6
 - 2) 5.52×10^7
 - 3) 55.2×10^7
 - 4) 5.52×10^{10}

- 28 Which notation describes $\{1, 2, 3\}$?
- 1) $\{x \mid 1 \leq x < 3, \text{ where } x \text{ is an integer}\}$
 - 2) $\{x \mid 0 < x \leq 3, \text{ where } x \text{ is an integer}\}$
 - 3) $\{x \mid 1 < x < 3, \text{ where } x \text{ is an integer}\}$
 - 4) $\{x \mid 0 \leq x \leq 3, \text{ where } x \text{ is an integer}\}$

- 29 What is $\frac{7}{12x} - \frac{y}{6x^2}$ expressed in simplest form?
- 1) $\frac{7-y}{6x}$
 - 2) $\frac{7-y}{12x-6x^2}$
 - 3) $-\frac{7y}{12x^2}$
 - 4) $\frac{7x-2y}{12x^2}$

- 30 When $5x + 4y$ is subtracted from $5x - 4y$, the difference is
- 1) 0
 - 2) $10x$
 - 3) $8y$
 - 4) $-8y$

- 31 The area of a rectangle is represented by $x^2 - 5x - 24$. If the width of the rectangle is represented by $x - 8$, express the length of the rectangle as a binomial.

- 32 A method for solving $5(x - 2) - 2(x - 5) = 9$ is shown below. Identify the property used to obtain each of the two indicated steps.

$$5(x - 2) - 2(x - 5) = 9$$

(1) $5x - 10 - 2x + 10 = 9$ (1) _____

(2) $5x - 2x - 10 + 10 = 9$ (2) _____

$$3x + 0 = 9$$

$$3x = 9$$

$$x = 3$$

- 33 State the equation of the axis of symmetry and the coordinates of the vertex of the parabola graphed below.

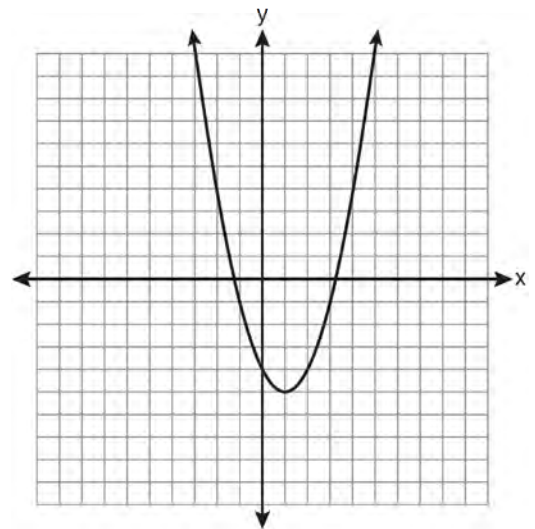

- 34 Given the following list of students' scores on a quiz:

5, 12, 7, 15, 20, 14, 7

Determine the median of these scores. Determine the mode of these scores. The teacher decides to adjust these scores by adding three points to each score. Explain the effect, if any, that this will have on the median and mode of these scores.

- 35 Chelsea has \$45 to spend at the fair. She spends \$20 on admission and \$15 on snacks. She wants to play a game that costs \$0.65 per game. Write an inequality to find the maximum number of times, x , Chelsea can play the game. Using this inequality, determine the maximum number of times she can play the game.

- 36 A plastic storage box in the shape of a rectangular prism has a length of $x + 3$, a width of $x - 4$, and a height of 5. Represent the surface area of the box as a trinomial in terms of x .

- 37 Solve algebraically for x : $\frac{3}{4} = \frac{-(x + 11)}{4x} + \frac{1}{2x}$

- 38 An outfit Jennifer wears to school consists of a top, a bottom, and shoes. Possible choices are listed below.

Tops: T-shirt, blouse, sweater

Bottoms: jeans, skirt, capris

Shoes: flip-flops, sneakers

List the sample space or draw a tree diagram to represent all possible outfits consisting of one type of top, one type of bottom, and one pair of shoes. Determine how many different outfits contain jeans and flip-flops. Determine how many different outfits do *not* include a sweater.

- 39 Solve the following system of inequalities graphically on the set of axes below.

$$3x + y < 7$$

$$y \geq \frac{2}{3}x - 4$$

State the coordinates of a point in the solution set.

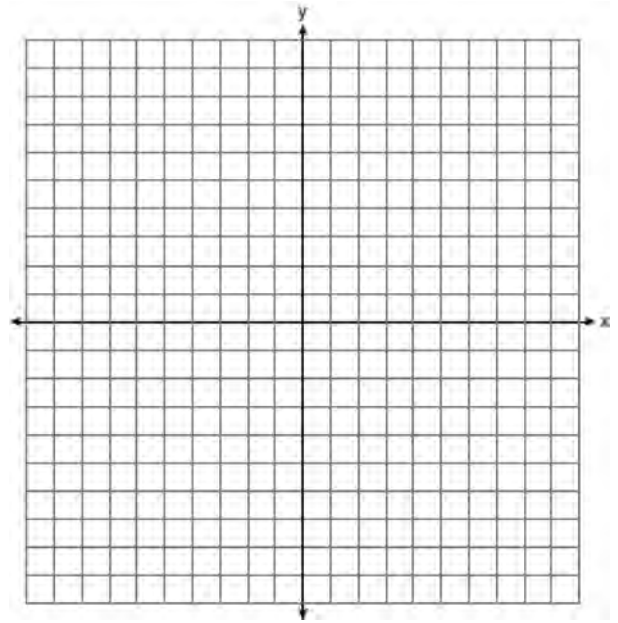

0811ia

- 1 The number of calories burned while jogging varies directly with the number of minutes spent jogging. If George burns 150 calories by jogging for 20 minutes, how many calories does he burn by jogging for 30 minutes?
- 1) 100
 - 2) 180
 - 3) 200
 - 4) 225

- 2 The scatter plot below represents the relationship between the number of peanuts a student eats and the student's bowling score.

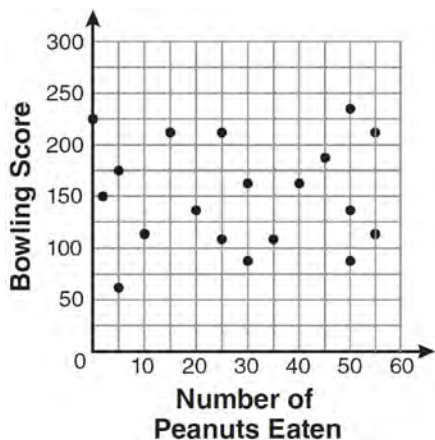

- Which conclusion about the scatter plot is valid?
- 1) There is almost no relationship between eating peanuts and bowling score.
 - 2) Students who eat more peanuts have higher bowling scores.
 - 3) Students who eat more peanuts have lower bowling scores.
 - 4) No bowlers eat peanuts.

- 3 If the universal set is {pennies, nickels, dimes, quarters}, what is the complement of the set {nickels}?
- 1) { }
 - 2) {pennies, quarters}
 - 3) {pennies, dimes, quarters}
 - 4) {pennies, nickels, dimes, quarters}
- 4 Which situation does *not* describe a causal relationship?
- 1) The higher the volume on a radio, the louder the sound will be.
 - 2) The faster a student types a research paper, the more pages the paper will have.
 - 3) The shorter the distance driven, the less gasoline that will be used.
 - 4) The slower the pace of a runner, the longer it will take the runner to finish the race.
- 5 A cylinder has a diameter of 10 inches and a height of 2.3 inches. What is the volume of this cylinder, to the *nearest tenth of a cubic inch*?
- 1) 72.3
 - 2) 83.1
 - 3) 180.6
 - 4) 722.6

- 6 Based on the box-and-whisker plot below, which statement is *false*?

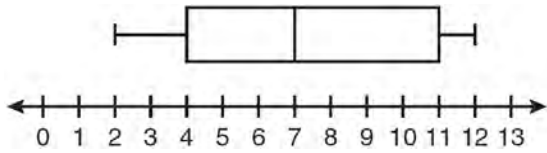

- 1) The median is 7.
 - 2) The range is 12.
 - 3) The first quartile is 4.
 - 4) The third quartile is 11.
- 7 The ninth grade class at a local high school needs to purchase a park permit for \$250.00 for their upcoming class picnic. Each ninth grader attending the picnic pays \$0.75. Each guest pays \$1.25. If 200 ninth graders attend the picnic, which inequality can be used to determine the number of guests, x , needed to cover the cost of the permit?
- 1) $0.75x - (1.25)(200) \geq 250.00$
 - 2) $0.75x + (1.25)(200) \geq 250.00$
 - 3) $(0.75)(200) - 1.25x \geq 250.00$
 - 4) $(0.75)(200) + 1.25x \geq 250.00$
- 8 Which equation represents the line that passes through the point $(1,5)$ and has a slope of -2 ?
- 1) $y = -2x + 7$
 - 2) $y = -2x + 11$
 - 3) $y = 2x - 9$
 - 4) $y = 2x + 3$

- 9 What is the solution of the system of equations $2x - 5y = 11$ and $-2x + 3y = -9$?

- 1) $(-3, -1)$
- 2) $(-1, 3)$
- 3) $(3, -1)$
- 4) $(3, 1)$

- 10 Which algebraic expression represents 15 less than x divided by 9?

- 1) $\frac{x}{9} - 15$
- 2) $9x - 15$
- 3) $15 - \frac{x}{9}$
- 4) $15 - 9x$

- 11 What are the vertex and the axis of symmetry of the parabola shown in the graph below?

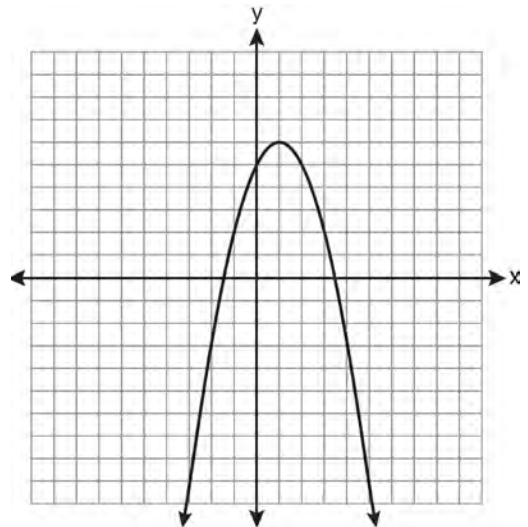

- 1) vertex: $(1, 6)$; axis of symmetry: $y = 1$
- 2) vertex: $(1, 6)$; axis of symmetry: $x = 1$
- 3) vertex: $(6, 1)$; axis of symmetry: $y = 1$
- 4) vertex: $(6, 1)$; axis of symmetry: $x = 1$

- 12 The diagram below shows right triangle ABC .

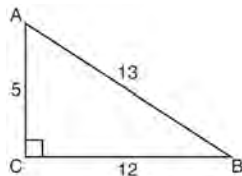

Which ratio represents the tangent of $\angle ABC$?

- 1) $\frac{5}{13}$
- 2) $\frac{5}{12}$
- 3) $\frac{12}{13}$
- 4) $\frac{12}{5}$

- 13 What is the value of the expression $-3x^2y + 4x$ when $x = -4$ and $y = 2$?

- 1) -112
- 2) -80
- 3) 80
- 4) 272

- 14 Which expression is equivalent to $-3x(x - 4) - 2x(x + 3)$?

- 1) $-x^2 - 1$
- 2) $-x^2 + 18x$
- 3) $-5x^2 - 6x$
- 4) $-5x^2 + 6x$

- 15 The data in the table below are graphed, and the slope is examined.

x	y
0.5	9.0
1	8.75
1.5	8.5
2	8.25
2.5	8.0

The rate of change represented in this table can be described as

- 1) negative
- 2) positive
- 3) undefined
- 4) zero

- 16 The length of a rectangle is 3 inches more than its width. The area of the rectangle is 40 square inches. What is the length, in inches, of the rectangle?

- 1) 5
- 2) 8
- 3) 8.5
- 4) 11.5

- 17 In interval notation, the set of all real numbers greater than -6 and less than or equal to 14 is represented by

- 1) $(-6, 14)$
- 2) $[-6, 14)$
- 3) $(-6, 14]$
- 4) $[-6, 14]$

Integrated Algebra Regents Exam 0811

www.jmap.org

- 18 Which equation represents a quadratic function?
- 1) $y = x + 2$
 - 2) $y = |x + 2|$
 - 3) $y = x^2$
 - 4) $y = 2^x$
- 19 Ben has four more than twice as many CDs as Jake. If they have a total of 31 CDs, how many CDs does Jake have?
- 1) 9
 - 2) 13
 - 3) 14
 - 4) 22
- 20 What are the roots of the equation $x^2 - 5x + 6 = 0$?
- 1) 1 and -6
 - 2) 2 and 3
 - 3) -1 and 6
 - 4) -2 and -3
- 21 What is the solution of the inequality $-6x - 17 \geq 8x + 25$?
- 1) $x \geq 3$
 - 2) $x \leq 3$
 - 3) $x \geq -3$
 - 4) $x \leq -3$
- 22 Which set of data can be classified as qualitative?
- 1) scores of students in an algebra class
 - 2) ages of students in a biology class
 - 3) numbers of students in history classes
 - 4) eye colors of students in an economics class
- 23 Jack wants to replace the flooring in his rectangular kitchen. He calculates the area of the floor to be 12.8 square meters. The actual area of the floor is 13.5 square meters. What is the relative error in calculating the area of the floor, to the *nearest thousandth*?
- 1) 0.051
 - 2) 0.052
 - 3) 0.054
 - 4) 0.055
- 24 The current student population of the Brentwood Student Center is 2,000. The enrollment at the center increases at a rate of 4% each year. To the *nearest whole number*, what will the student population be closest to in 3 years'?
- 1) 2,240
 - 2) 2,250
 - 3) 5,488
 - 4) 6,240
- 25 Maria has a set of 10 index cards labeled with the digits 0 through 9. She puts them in a bag and selects one at random. The outcome that is most likely to occur is selecting
- 1) an odd number
 - 2) a prime number
 - 3) a number that is at most 5
 - 4) a number that is divisible by 3
- 26 A right triangle contains a 38° angle whose adjacent side measures 10 centimeters. What is the length of the hypotenuse, to the *nearest hundredth of a centimeter*?
- 1) 7.88
 - 2) 12.69
 - 3) 12.80
 - 4) 16.24

- 27 Which ordered pair is in the solution set of the system of inequalities shown in the graph below?

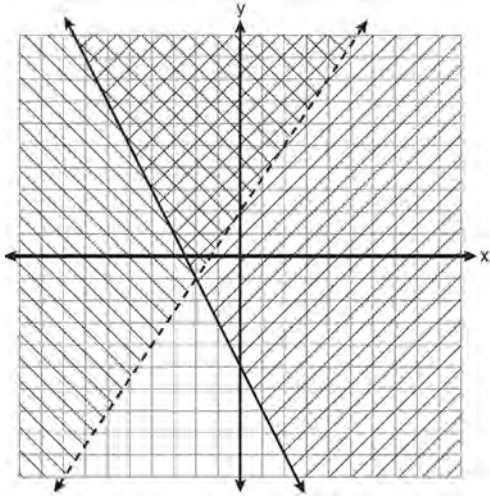

- 1) $(-2, -1)$
- 2) $(-2, 2)$
- 3) $(-2, -4)$
- 4) $(2, -2)$

- 28 A garden is in the shape of an isosceles trapezoid and a semicircle, as shown in the diagram below. A fence will be put around the perimeter of the entire garden.

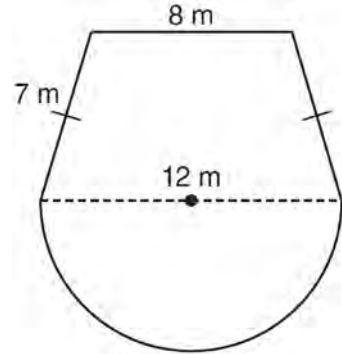

Which expression represents the length of fencing, in meters, that will be needed?

- 1) $22 + 6\pi$
 - 2) $22 + 12\pi$
 - 3) $15 + 6\pi$
 - 4) $15 + 12\pi$
- 29 Which expression represents $36x^2 - 100y^6$ factored completely?
- 1) $2(9x + 25y^3)(9x - 25y^3)$
 - 2) $4(3x + 5y^3)(3x - 5y^3)$
 - 3) $(6x + 10y^3)(6x - 10y^3)$
 - 4) $(18x + 50y^3)(18x - 50y^3)$

30 What is the quotient of $\frac{x}{x+4}$ divided by $\frac{2x}{x^2-16}$?

- 1) $\frac{2}{x-4}$
- 2) $\frac{2x^2}{x-4}$
- 3) $\frac{2x^2}{x^2-16}$
- 4) $\frac{x-4}{2}$

31 Solve for c in terms of a and b : $bc + ac = ab$

32 Ms. Hopkins recorded her students' final exam scores in the frequency table below.

Interval	Tally	Frequency
61–70	###	5
71–80		4
81–90	###	9
91–100	###	6

On the grid below, construct a frequency histogram based on the table.

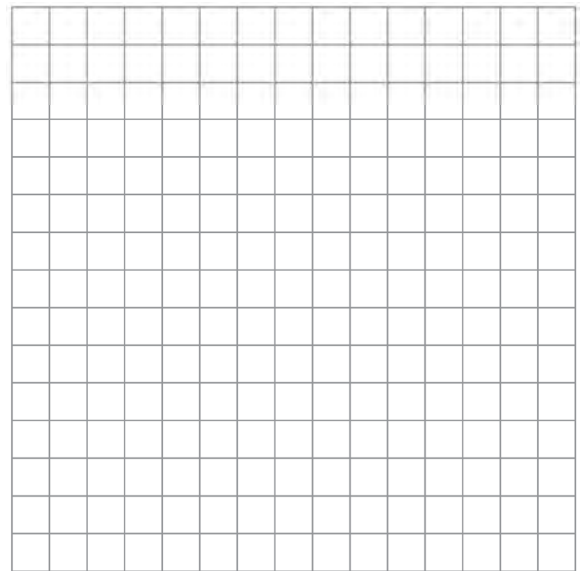

33 Mrs. Chen owns two pieces of property. The areas of the properties are 77,120 square feet and 33,500 square feet.

43,560 square feet = 1 acre

Find the total number of acres Mrs. Chen owns, to the *nearest hundredth of an acre*.

- 34 On the set of axes below, graph and label the equations $y = |x|$ and $y = 3|x|$ for the interval $-3 \leq x \leq 3$.

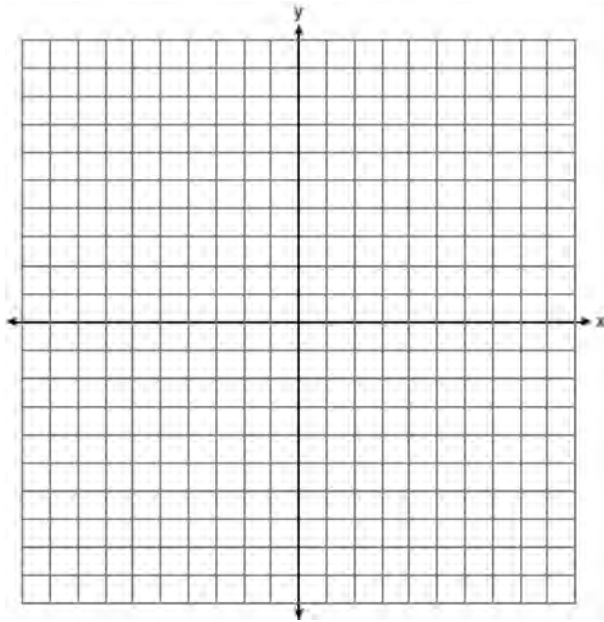

Explain how changing the coefficient of the absolute value from 1 to 3 affects the graph.

- 35 A trapezoid is shown below.

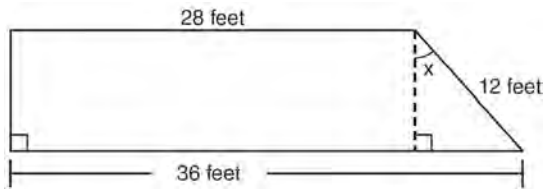

Calculate the measure of angle x , to the *nearest tenth of a degree*.

- 36 Express $\frac{16\sqrt{21}}{2\sqrt{7}} - 5\sqrt{12}$ in simplest radical form.

- 37 Vince buys a box of candy that consists of six chocolate pieces, four fruit-flavored pieces, and two mint pieces. He selects three pieces of candy at random, without replacement. Calculate the probability that the first piece selected will be fruit flavored and the other two will be mint. Calculate the probability that all three pieces selected will be the same type of candy.

- 38 On the set of axes below, solve the following system of equations graphically and state the coordinates of *all* points in the solution set.

$$y = -x^2 + 6x - 3$$

$$x + y = 7$$

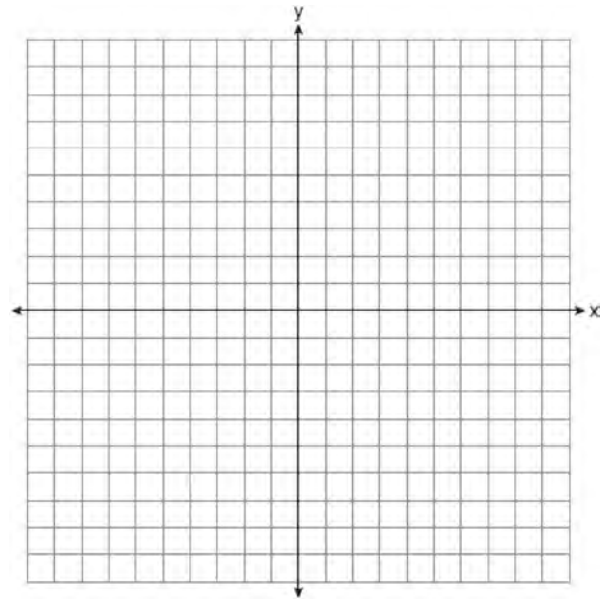

- 39 Solve for m : $\frac{m}{5} + \frac{3(m-1)}{2} = 2(m-3)$

0112ia

1 Which expression is equivalent to $64 - x^2$?

- 1) $(8 - x)(8 - x)$
- 2) $(8 - x)(8 + x)$
- 3) $(x - 8)(x - 8)$
- 4) $(x - 8)(x + 8)$

2 Mr. Smith invested \$2,500 in a savings account that earns 3% interest compounded annually. He made no additional deposits or withdrawals. Which expression can be used to determine the number of dollars in this account at the end of 4 years?

- 1) $2500(1 + 0.03)^4$
- 2) $2500(1 + 0.3)^4$
- 3) $2500(1 + 0.04)^3$
- 4) $2500(1 + 0.4)^3$

3 What is $2\sqrt{45}$ expressed in simplest radical form?

- 1) $3\sqrt{5}$
- 2) $5\sqrt{5}$
- 3) $6\sqrt{5}$
- 4) $18\sqrt{5}$

4 Which graph does *not* represent a function?

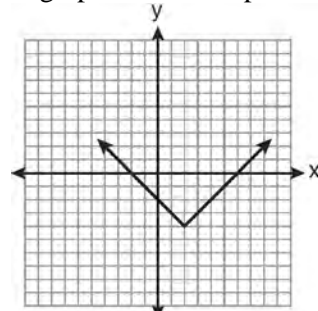

1)

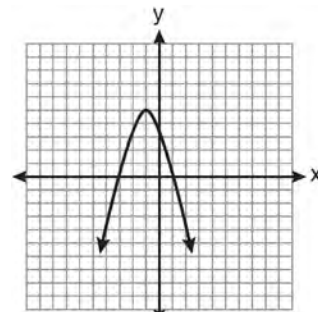

2)

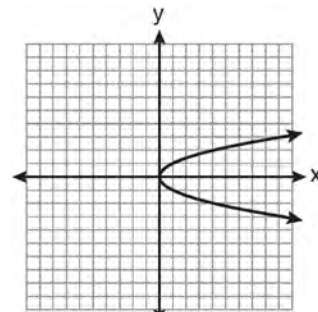

3)

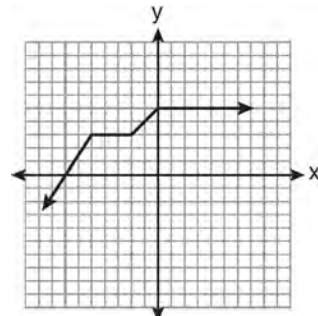

4)

5 Timmy bought a skateboard and two helmets for a total of d dollars. If each helmet cost h dollars, the cost of the skateboard could be represented by

- 1) $2dh$
- 2) $\frac{dh}{2}$
- 3) $d - 2h$
- 4) $d - \frac{h}{2}$

6 The graph of $y = |x + 2|$ is shown below.

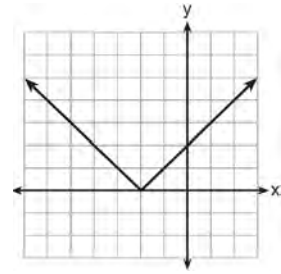

Which graph represents $y = -|x + 2|$?

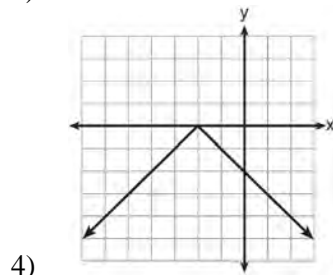
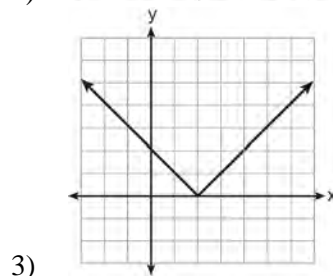
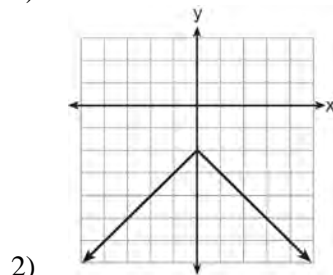
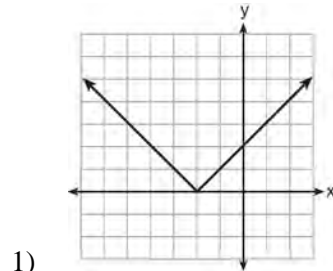

- 7 Two equations were graphed on the set of axes below.

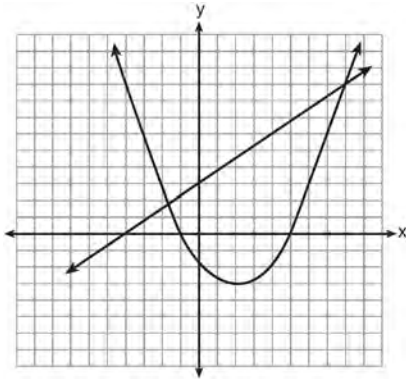

Which point is a solution of the system of equations shown on the graph?

- 1) (8,9)
 - 2) (5,0)
 - 3) (0,3)
 - 4) (2,-3)
- 8 Byron is 3 years older than Doug. The product of their ages is 40. How old is Doug?
- 1) 10
 - 2) 8
 - 3) 5
 - 4) 4
- 9 The actual dimensions of a rectangle are 2.6 cm by 6.9 cm. Andy measures the sides as 2.5 cm by 6.8 cm. In calculating the area, what is the relative error, to the *nearest thousandth*?
- 1) 0.055
 - 2) 0.052
 - 3) 0.022
 - 4) 0.021

- 10 Which graph represents the inequality $y > 3$?

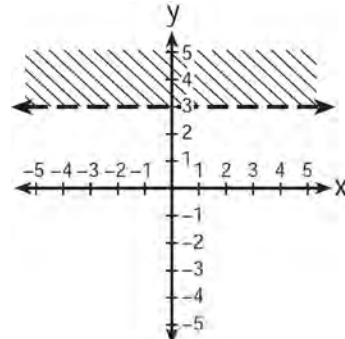

1)

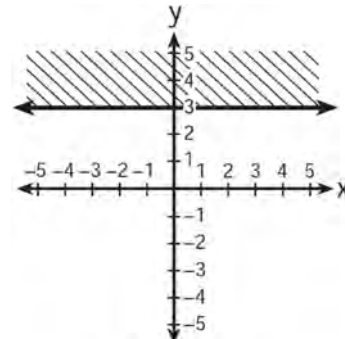

2)

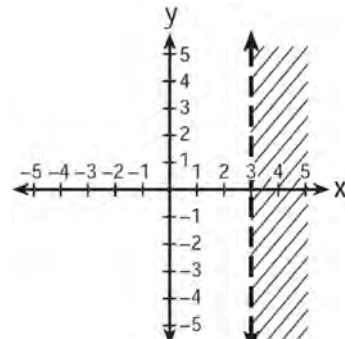

3)

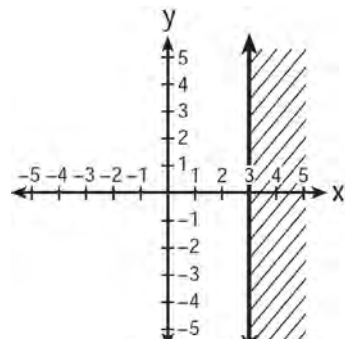

4)

- 11 Which set of data can be classified as quantitative?
- 1) first names of students in a chess club
 - 2) ages of students in a government class
 - 3) hair colors of students in a debate club
 - 4) favorite sports of students in a gym class

- 12 Three fair coins are tossed. What is the probability that two heads and one tail appear?

- 1) $\frac{1}{8}$
- 2) $\frac{3}{8}$
- 3) $\frac{3}{6}$
- 4) $\frac{2}{3}$

- 13 What is the sum of $-3x^2 - 7x + 9$ and $-5x^2 + 6x - 4$?

- 1) $-8x^2 - x + 5$
- 2) $-8x^4 - x + 5$
- 3) $-8x^2 - 13x + 13$
- 4) $-8x^4 - 13x^2 + 13$

- 14 For which values of x is the fraction $\frac{x^2 + x - 6}{x^2 + 5x - 6}$ undefined?

- 1) 1 and -6
- 2) 2 and -3
- 3) 3 and -2
- 4) 6 and -1

- 15 What is the slope of the line that passes through the points $(2, -3)$ and $(5, 1)$?

- 1) $-\frac{2}{3}$
- 2) $\frac{2}{3}$
- 3) $-\frac{4}{3}$
- 4) $\frac{4}{3}$

- 16 The expression $\frac{(4x^3)^2}{2x}$ is equivalent to

- 1) $4x^4$
- 2) $4x^5$
- 3) $8x^4$
- 4) $8x^5$

- 17 In the diagram below, circle O is inscribed in square $ABCD$. The square has an area of 36.

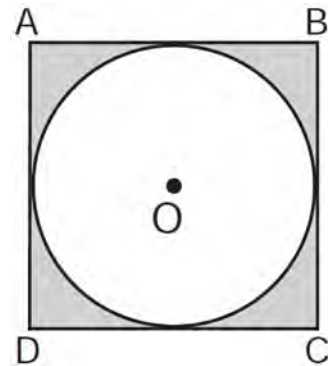

What is the area of the circle?

- 1) 9π
- 2) 6π
- 3) 3π
- 4) 36π

- 18 Which point lies on the graph represented by the equation $3y + 2x = 8$?

- 1) $(-2, 7)$
- 2) $(0, 4)$
- 3) $(2, 4)$
- 4) $(7, -2)$

19 The equation of the axis of symmetry of the graph of $y = 2x^2 - 3x + 7$ is

- 1) $x = \frac{3}{4}$
- 2) $y = \frac{3}{4}$
- 3) $x = \frac{3}{2}$
- 4) $y = \frac{3}{2}$

20 The box-and-whisker plot below represents the ages of 12 people.

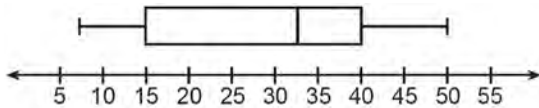

What percentage of these people are age 15 or older?

- 1) 25
- 2) 35
- 3) 75
- 4) 85

21 Campsite A and campsite B are located directly opposite each other on the shores of Lake Omega, as shown in the diagram below. The two campsites form a right triangle with Sam's position, S . The distance from campsite B to Sam's position is 1,300 yards, and campsite A is 1,700 yards from his position.

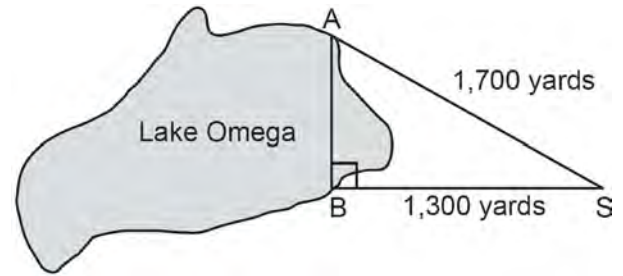

What is the distance from campsite A to campsite B , to the nearest yard?

- 1) 1,095
- 2) 1,096
- 3) 2,140
- 4) 2,141

22 Which set builder notation describes $\{-2, -1, 0, 1, 2, 3\}$?

- 1) $\{x | -3 \leq x \leq 3, \text{ where } x \text{ is an integer}\}$
- 2) $\{x | -3 < x \leq 4, \text{ where } x \text{ is an integer}\}$
- 3) $\{x | -2 < x < 3, \text{ where } x \text{ is an integer}\}$
- 4) $\{x | -2 \leq x < 4, \text{ where } x \text{ is an integer}\}$

23 The roots of the equation $3x^2 - 27x = 0$ are

- 1) 0 and 9
- 2) 0 and -9
- 3) 0 and 3
- 4) 0 and -3

24 Which equation is an example of the use of the associative property of addition?

- 1) $x + 7 = 7 + x$
- 2) $3(x + y) = 3x + 3y$
- 3) $(x + y) + 3 = x + (y + 3)$
- 4) $3 + (x + y) = (x + y) + 3$

25 Given: $A = \{2,4,5,7,8\}$

$B = \{3,5,8,9\}$

What is $A \cup B$?

- 1) $\{5\}$
- 2) $\{5,8\}$
- 3) $\{2,3,4,7,9\}$
- 4) $\{2,3,4,5,7,8,9\}$

26 The diagram below shows right triangle LMP .

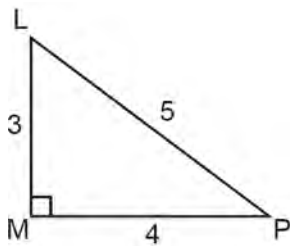

Which ratio represents the tangent of $\angle PLM$?

- 1) $\frac{3}{4}$
- 2) $\frac{3}{5}$
- 3) $\frac{4}{3}$
- 4) $\frac{5}{4}$

27 Mr. Stanton asked his students to write an algebraic expression on a piece of paper. He chose four students to go to the board and write their expression.

Robert wrote: $4(2x + 5) \geq 17$

Meredith wrote: $3y - 7 + 11z$

Steven wrote: $9w + 2 = 20$

Cynthia wrote: $8 + 10 - 4 = 14$

Which student wrote an algebraic expression?

- 1) Robert
- 2) Meredith
- 3) Steven
- 4) Cynthia

28 If $s = \frac{2x+t}{r}$, then x equals

- 1) $\frac{rs-t}{2}$
- 2) $\frac{rs+1}{2}$
- 3) $2rs-t$
- 4) $rs-2t$

29 A scatter plot was constructed on the graph below and a line of best fit was drawn.

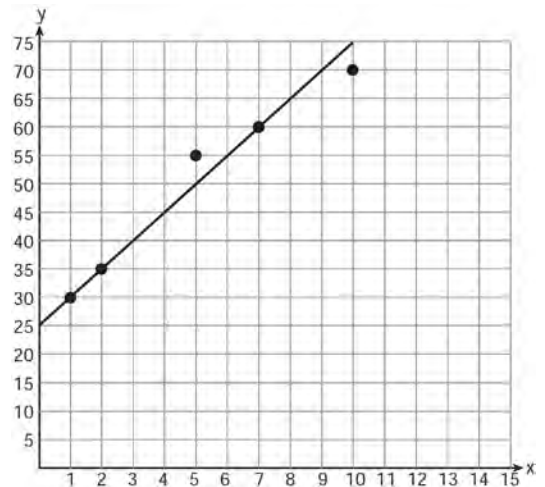

What is the equation of this line of best fit?

- 1) $y = x + 5$
- 2) $y = x + 25$
- 3) $y = 5x + 5$
- 4) $y = 5x + 25$

30 What is the sum of $\frac{2y}{y+5}$ and $\frac{10}{y+5}$ expressed in simplest form?

- 1) 1
- 2) 2
- 3) $\frac{12y}{y+5}$
- 4) $\frac{2y+10}{y+5}$

- 31 The length and width of the base of a rectangular prism are 5.5 cm and 3 cm. The height of the prism is 6.75 cm. Find the *exact* value of the surface area of the prism, in square centimeters.
- 32 Casey purchased a pack of assorted flower seeds and planted them in her garden. When the first 25 flowers bloomed, 11 were white, 5 were red, 3 were blue, and the rest were yellow. Find the empirical probability that a flower that blooms will be yellow.

33 Express in simplest form: $\frac{x^2 - 1}{x^2 + 3x + 2}$

34 Solve algebraically for x : $2(x - 4) \geq \frac{1}{2}(5 - 3x)$

- 35 On the set of axes below, solve the following system of equations graphically. State the coordinates of the solution.

$$y = 4x - 1$$

$$2x + y = 5$$

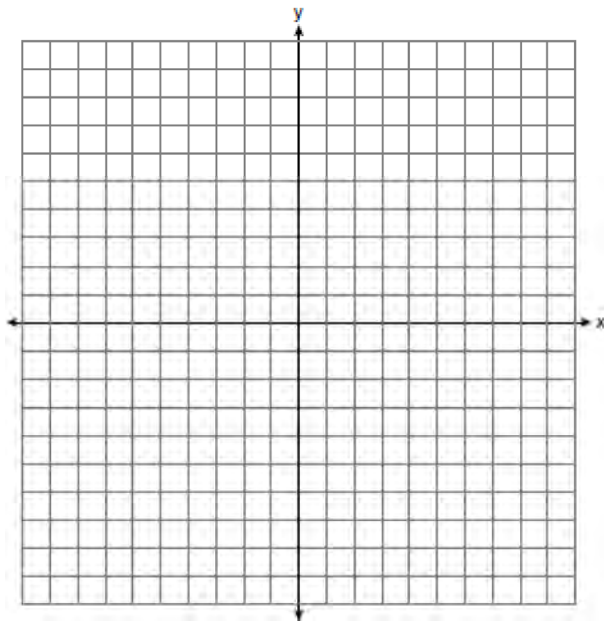

- 36 A turtle and a rabbit are in a race to see who is first to reach a point 100 feet away. The turtle travels at a constant speed of 20 feet per minute for the entire 100 feet. The rabbit travels at a constant speed of 40 feet per minute for the first 50 feet, stops for 3 minutes, and then continues at a constant speed of 40 feet per minute for the last 50 feet. Determine which animal won the race and by how much time.
- 37 The sum of three consecutive odd integers is 18 less than five times the middle number. Find the three integers. [Only an algebraic solution can receive full credit.]
- 38 A sandwich consists of one type of bread, one type of meat, and one type of cheese. The possible choices are listed below.
 Bread: white, rye
 Meat: ham, turkey, beef
 Cheese: American, Swiss
 Draw a tree diagram or list a sample space of all the possible different sandwiches consisting of one type of bread, one type of meat, and one type of cheese. Determine the number of sandwiches that will *not* include turkey. Determine the number of sandwiches that will include rye bread and Swiss cheese.
- 39 Shana wants to buy a new bicycle that has a retail price of \$259.99. She knows that it will be on sale next week for 30% off the retail price. If the tax rate is 7%, find the total amount, to the *nearest cent*, that she will save by waiting until next week.

0612ia

- 1 In a baseball game, the ball traveled 350.7 feet in 4.2 seconds. What was the average speed of the ball, in feet per second?
 - 1) 83.5
 - 2) 177.5
 - 3) 354.9
 - 4) 1,472.9

- 2 A survey is being conducted to determine if a cable company should add another sports channel to their schedule. Which random survey would be the least biased?
 - 1) surveying 30 men at a gym
 - 2) surveying 45 people at a mall
 - 3) surveying 50 fans at a football game
 - 4) surveying 20 members of a high school soccer team

- 3 The quotient of $\frac{8x^5 - 2x^4 + 4x^3 - 6x^2}{2x^2}$ is
 - 1) $16x^7 - 4x^6 + 8x^5 - 12x^4$
 - 2) $4x^7 - x^6 + 2x^5 - 3x^4$
 - 3) $4x^3 - x^2 + 2x - 3x$
 - 4) $4x^3 - x^2 + 2x - 3$

- 4 Marcy determined that her father's age is four less than three times her age. If x represents Marcy's age, which expression represents her father's age?
 - 1) $3x - 4$
 - 2) $3(x - 4)$
 - 3) $4x - 3$
 - 4) $4 - 3x$

- 5 A set of data is graphed on the scatter plot below.

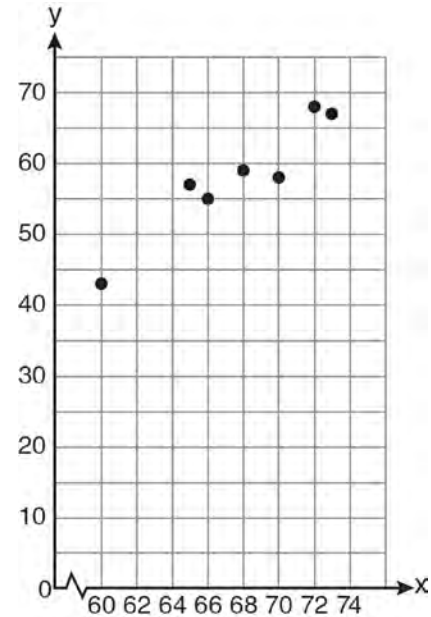

This scatter plot shows

- 1) no correlation
 - 2) positive correlation
 - 3) negative correlation
 - 4) undefined correlation
-
- 6 Which situation is an example of bivariate data?
 - 1) the number of pizzas Tanya eats during her years in high school
 - 2) the number of times Ezra puts air, in his bicycle tires during the summer
 - 3) the number of home runs Elias hits per game and the number of hours he practices baseball
 - 4) the number of hours Nellie studies for her mathematics tests during the first half of the school year

7 Brianna's score on a national math assessment exceeded the scores of 95,000 of the 125,000 students who took the assessment. What was her percentile rank?

- 1) 6
- 2) 24
- 3) 31
- 4) 76

8 If $A = \{0, 1, 3, 4, 6, 7\}$, $B = \{0, 2, 3, 5, 6\}$, and $C = \{0, 1, 4, 6, 7\}$, then $A \cap B \cap C$ is

- 1) $\{0, 1, 2, 3, 4, 5, 6, 7\}$
- 2) $\{0, 3, 6\}$
- 3) $\{0, 6\}$
- 4) $\{0\}$

9 Which graph represents a function?

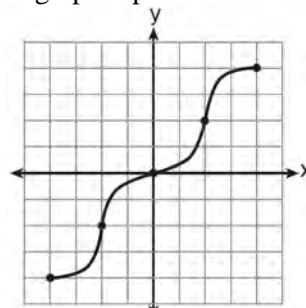

1)

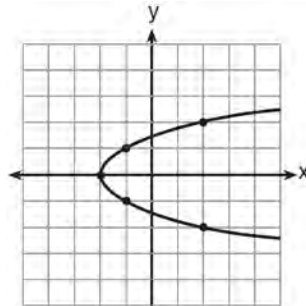

2)

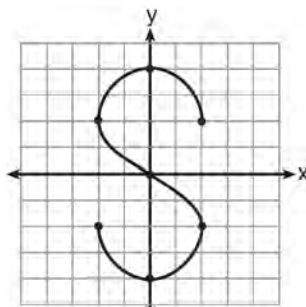

3)

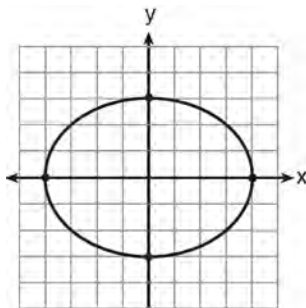

4)

Integrated Algebra Regents Exam 0612

www.jmap.org

- 10 What is the product of $(3x + 2)$ and $(x - 7)$?
- 1) $3x^2 - 14$
 - 2) $3x^2 - 5x - 14$
 - 3) $3x^2 - 19x - 14$
 - 4) $3x^2 - 23x - 14$
- 11 If five times a number is less than 55, what is the greatest possible integer value of the number?
- 1) 12
 - 2) 11
 - 3) 10
 - 4) 9
- 12 The line represented by the equation $2y - 3x = 4$ has a slope of
- 1) $-\frac{3}{2}$
 - 2) 2
 - 3) 3
 - 4) $\frac{3}{2}$
- 13 What is the solution set of the system of equations $x + y = 5$ and $y = x^2 - 25$?
- 1) $\{(0, 5), (11, -6)\}$
 - 2) $\{(5, 0), (-6, 11)\}$
 - 3) $\{(-5, 0), (6, 11)\}$
 - 4) $\{(-5, 10), (6, -1)\}$
- 14 What is the vertex of the parabola represented by the equation $y = -2x^2 + 24x - 100$?
- 1) $x = -6$
 - 2) $x = 6$
 - 3) $(6, -28)$
 - 4) $(-6, -316)$
- 15 If $k = am + 3mx$, the value of m in terms of a , k , and x can be expressed as
- 1) $\frac{k}{a + 3x}$
 - 2) $\frac{k - 3mx}{a}$
 - 3) $\frac{k - am}{3x}$
 - 4) $\frac{k - a}{3x}$
- 16 Which expression represents $\frac{x^2 - 3x - 10}{x^2 - 25}$ in simplest form?
- 1) $\frac{2}{5}$
 - 2) $\frac{x + 2}{x + 5}$
 - 3) $\frac{x - 2}{x - 5}$
 - 4) $\frac{-3x - 10}{-25}$
- 17 Which interval notation describes the set $S = \{x \mid 1 \leq x < 10\}$?
- 1) $[1, 10]$
 - 2) $(1, 10]$
 - 3) $[1, 10)$
 - 4) $(1, 10)$

- 18 The bull's-eye of a dartboard has a radius of 2 inches and the entire board has a radius of 9 inches, as shown in the diagram below.

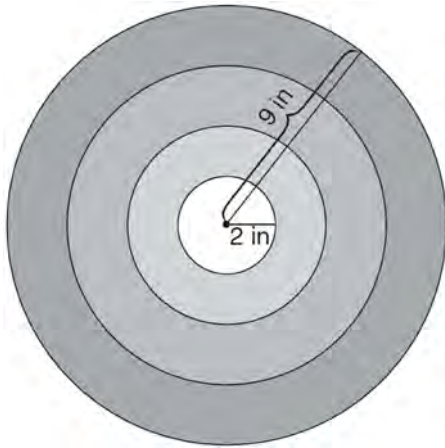

If a dart is thrown and hits the board, what is the probability that the dart will land in the bull's-eye?

- 1) $\frac{2}{9}$
 - 2) $\frac{7}{9}$
 - 3) $\frac{4}{81}$
 - 4) $\frac{49}{81}$
- 19 What is one-third of 3^6 ?
- 1) 1^2
 - 2) 3^2
 - 3) 3^5
 - 4) 9^6

- 20 The expression $\frac{2x+13}{2x+6} - \frac{3x-6}{2x+6}$ is equivalent to

- 1) $\frac{-x+19}{2(x+3)}$
- 2) $\frac{-x+7}{2(x+3)}$
- 3) $\frac{5x+19}{2(x+3)}$
- 4) $\frac{5x+7}{4x+12}$

- 21 Which equation is represented by the graph below?

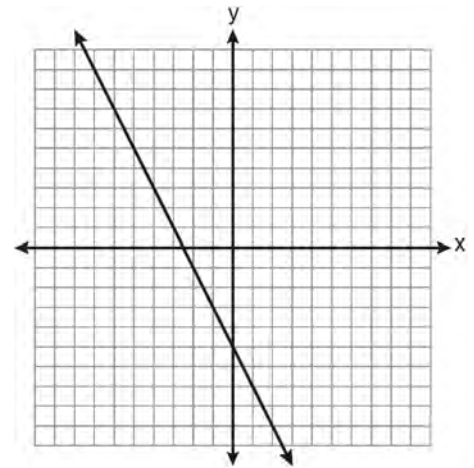

- 1) $2y + x = 10$
- 2) $y - 2x = -5$
- 3) $-2y = 10x - 4$
- 4) $2y = -4x - 10$

- 22 Which coordinates represent a point in the solution set of the system of inequalities shown below?

$$y \leq \frac{1}{2}x + 13$$

$$4x + 2y > 3$$

- 1) $(-4, 1)$
 2) $(-2, 2)$
 3) $(1, -4)$
 4) $(2, -2)$
- 23 The length of one side of a square is 13 feet. What is the length, to the *nearest foot*, of a diagonal of the square?
- 1) 13
 2) 18
 3) 19
 4) 26
- 24 In $\triangle ABC$, $m\angle C = 90$. If $AB = 5$ and $AC = 4$, which statement is *not* true?
- 1) $\cos A = \frac{4}{5}$
 2) $\tan A = \frac{3}{4}$
 3) $\sin B = \frac{4}{5}$
 4) $\tan B = \frac{5}{3}$
- 25 If n is an odd integer, which equation can be used to find three consecutive odd integers whose sum is -3 ?
- 1) $n + (n + 1) + (n + 3) = -3$
 2) $n + (n + 1) + (n + 2) = -3$
 3) $n + (n + 2) + (n + 4) = -3$
 4) $n + (n + 2) + (n + 3) = -3$

- 26 When $8x^2 + 3x + 2$ is subtracted from $9x^2 - 3x - 4$, the result is

1) $x^2 - 2$

2) $17x^2 - 2$

3) $-x^2 + 6x + 6$

4) $x^2 - 6x - 6$

- 27 Factored completely, the expression

$$3x^3 - 33x^2 + 90x$$

1) $3x(x^2 - 33x + 90)$

2) $3x(x^2 - 11x + 30)$

3) $3x(x + 5)(x + 6)$

4) $3x(x - 5)(x - 6)$

- 28 Elizabeth is baking chocolate chip cookies. A single batch uses $\frac{3}{4}$ teaspoon of vanilla. If Elizabeth is mixing the ingredients for five batches at the same time, how many tablespoons of vanilla will she use?

$$3 \text{ teaspoons} = 1 \text{ tablespoon}$$

1) $1\frac{1}{4}$

2) $1\frac{3}{4}$

3) $3\frac{3}{4}$

4) $5\frac{3}{4}$

- 29 A car depreciates (loses value) at a rate of 4.5% annually. Greg purchased a car for \$12,500. Which equation can be used to determine the value of the car, V , after 5 years?

- 1) $V = 12,500(0.55)^5$
- 2) $V = 12,500(0.955)^5$
- 3) $V = 12,500(1.045)^5$
- 4) $V = 12,500(1.45)^5$

- 30 The cumulative frequency table below shows the length of time that 30 students spent text messaging on a weekend.

Minutes Used	Cumulative Frequency
31–40	2
31–50	5
31–60	10
31–70	19
31–80	30

Which 10-minute interval contains the first quartile?

- 1) 31 – 40
- 2) 41 – 50
- 3) 51 – 60
- 4) 61 – 70

- 31 Solve the following system of equations algebraically for y :

$$2x + 2y = 9$$

$$2x - y = 3$$

- 32 Three storage bins contain colored blocks. Bin 1 contains 15 red and 14 blue blocks. Bin 2 contains 16 white and 15 blue blocks. Bin 3 contains 15 red and 15 white blocks. All of the blocks from the three bins are placed into one box. If one block is randomly selected from the box, which color block would most likely be picked? Justify your answer.

- 33 Students calculated the area of a playing field to be 8,100 square feet. The actual area of the field is 7,678.5 square feet. Find the relative error in the area, to the *nearest thousandth*.

- 34 On the set of axes below, graph the equation $y = x^2 + 2x - 8$. Using the graph, determine and state the roots of the equation $x^2 + 2x - 8 = 0$.

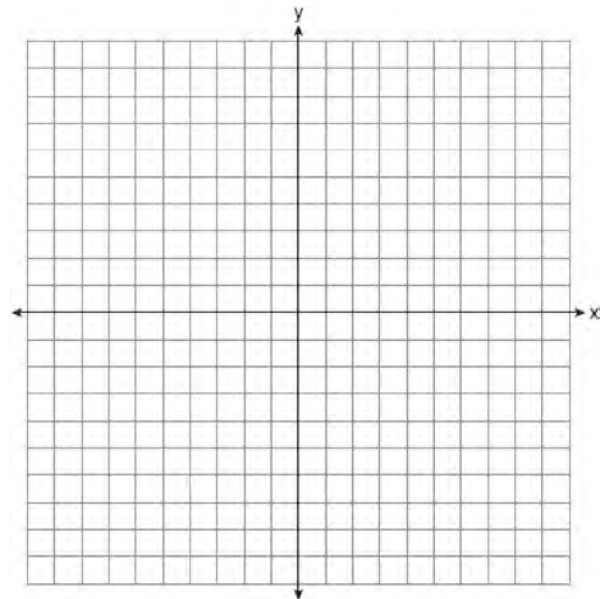

Integrated Algebra Regents Exam 0612

www.jmap.org

- 35 A 28-foot ladder is leaning against a house. The bottom of the ladder is 6 feet from the base of the house. Find the measure of the angle formed by the ladder and the ground, to the *nearest degree*.
- 36 Express $\frac{3\sqrt{75} + \sqrt{27}}{3}$ in simplest radical form.
- 37 Mike buys his ice cream packed in a rectangular prism-shaped carton, while Carol buys hers in a cylindrical-shaped carton. The dimensions of the prism are 5 inches by 3.5 inches by 7 inches. The cylinder has a diameter of 5 inches and a height of 7 inches. Which container holds more ice cream? Justify your answer. Determine, to the *nearest tenth of a cubic inch*, how much more ice cream the larger container holds.
- 38 Solve algebraically for x :
 $3(x + 1) - 5x = 12 - (6x - 7)$
- 39 A large company must choose between two types of passwords to log on to a computer. The first type is a four-letter password using any of the 26 letters of the alphabet, without repetition of letters. The second type is a six-digit password using the digits 0 through 9, with repetition of digits allowed. Determine the number of possible four-letter passwords. Determine the number of possible six-digit passwords. The company has 500,000 employees and needs a different password for each employee. State which type of password the company should choose. Explain your answer.

0812ia

- 1 A system of equations is graphed on the set of axes below.

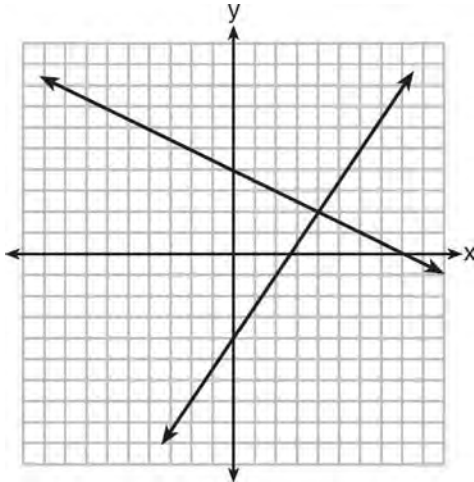

The solution of this system is

- 1) (0, 4)
 - 2) (2, 4)
 - 3) (4, 2)
 - 4) (8, 0)
- 2 A cell phone can receive 120 messages per minute. At this rate, how many messages can the phone receive in 150 seconds?
- 1) 48
 - 2) 75
 - 3) 300
 - 4) 18,000
- 3 The value of y in the equation $0.06y + 200 = 0.03y + 350$ is
- 1) 500
 - 2) 1,666. $\bar{6}$
 - 3) 5,000
 - 4) 18,333. $\bar{3}$

- 4 The scatter plot shown below represents a relationship between x and y .

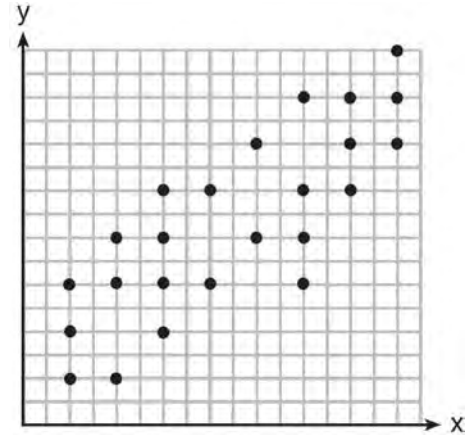

This type of relationship is

- 1) a positive correlation
 - 2) a negative correlation
 - 3) a zero correlation
 - 4) not able to be determined
- 5 The sum of $3x^2 + 5x - 6$ and $-x^2 + 3x + 9$ is
- 1) $2x^2 + 8x - 15$
 - 2) $2x^2 + 8x + 3$
 - 3) $2x^4 + 8x^2 + 3$
 - 4) $4x^2 + 2x - 15$
- 6 Jason's part-time job pays him \$155 a week. If he has already saved \$375, what is the minimum number of weeks he needs to work in order to have enough money to buy a dirt bike for \$900?
- 1) 8
 - 2) 9
 - 3) 3
 - 4) 4
- 7 The expression $9a^2 - 64b^2$ is equivalent to
- 1) $(9a - 8b)(a + 8b)$
 - 2) $(9a - 8b)(a - 8b)$
 - 3) $(3a - 8b)(3a + 8b)$
 - 4) $(3a - 8b)(3a - 8b)$

- 8 The scatter plot below shows the profit, by month, for a new company for the first year of operation. Kate drew a line of best fit, as shown in the diagram.

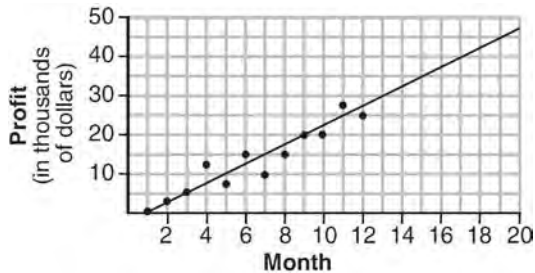

Using this line, what is the best estimate for profit in the 18th month?

- 1) \$35,000
 - 2) \$37,750
 - 3) \$42,500
 - 4) \$45,000
- 9 Which statement illustrates the additive identity property?
- 1) $6 + 0 = 6$
 - 2) $-6 + 6 = 0$
 - 3) $4(6 + 3) = 4(6) + 4(3)$
 - 4) $(4 + 6) + 3 = 4 + (6 + 3)$
- 10 Peter walked 8,900 feet from home to school.

$1 \text{ mile} = 5,280 \text{ feet}$

How far, to the *nearest tenth of a mile*, did he walk?

- 1) 0.5
 - 2) 0.6
 - 3) 1.6
 - 4) 1.7
- 11 Is the equation $A = 21000(1 - 0.12)^t$ a model of exponential growth or exponential decay, and what is the rate (percent) of change per time period?
- 1) exponential growth and 12%
 - 2) exponential growth and 88%
 - 3) exponential decay and 12%
 - 4) exponential decay and 88%

- 12 The length of a rectangle is 15 and its width is w . The perimeter of the rectangle is, *at most*, 50. Which inequality can be used to find the longest possible width?
- 1) $30 + 2w < 50$
 - 2) $30 + 2w \leq 50$
 - 3) $30 + 2w > 50$
 - 4) $30 + 2w \geq 50$
- 13 Craig sees an advertisement for a car in a newspaper. Which information would *not* be classified as quantitative?
- 1) the cost of the car
 - 2) the car's mileage
 - 3) the model of the car
 - 4) the weight of the car
- 14 What are the coordinates of the vertex and the equation of the axis of symmetry of the parabola shown in the graph below?

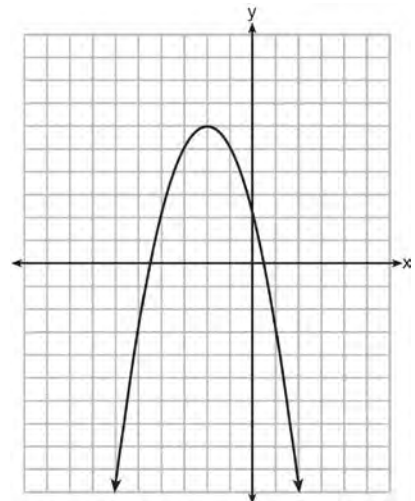

- 1) (0, 2) and $y = 2$
 - 2) (0, 2) and $x = 2$
 - 3) (-2, 6) and $y = -2$
 - 4) (-2, 6) and $x = -2$
- 15 A correct translation of "six less than twice the value of x " is
- 1) $2x < 6$
 - 2) $2x - 6$
 - 3) $6 < 2x$
 - 4) $6 - 2x$

- 16 The rectangular prism shown below has a length of 3.0 cm, a width of 2.2 cm, and a height of 7.5 cm.

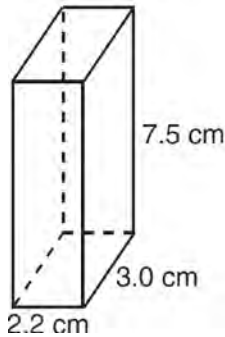

What is the surface area, in square centimeters?

- 1) 45.6
 - 2) 49.5
 - 3) 78.0
 - 4) 91.2
- 17 Which set of coordinates is a solution of the equation $2x - y = 11$?
- 1) $(-6, 1)$
 - 2) $(-1, 9)$
 - 3) $(0, 11)$
 - 4) $(2, -7)$
- 18 The graph of a parabola is represented by the equation $y = ax^2$ where a is a positive integer. If a is multiplied by 2, the new parabola will become
- 1) narrower and open downward
 - 2) narrower and open upward
 - 3) wider and open downward
 - 4) wider and open upward
- 19 Which equation represents a line that has a slope of $\frac{3}{4}$ and passes through the point $(2, 1)$?
- 1) $3y = 4x - 5$
 - 2) $3y = 4x + 2$
 - 3) $4y = 3x - 2$
 - 4) $4y = 3x + 5$

- 20 What is the value of $\left| \frac{4(-6) + 18}{4!} \right|$?

- 1) $\frac{1}{4}$
 - 2) $-\frac{1}{4}$
 - 3) 12
 - 4) -12
- 21 Given: $A = \{1, 3, 5, 7, 9\}$
 $B = \{2, 4, 6, 8, 10\}$
 $C = \{2, 3, 5, 7\}$
 $D = \{1, 2, 3, 4, 5, 6, 7, 8, 9, 10\}$

What statement is *false*?

- 1) $A \cup B \cup C = D$
 - 2) $A \cap B \cap C = \{ \}$
 - 3) $A \cup C = \{1, 2, 3, 5, 7\}$
 - 4) $A \cap C = \{3, 5, 7\}$
- 22 Which expression is equivalent to $\frac{2x^6 - 18x^4 + 2x^2}{2x^2}$?
- 1) $x^3 - 9x^2$
 - 2) $x^4 - 9x^2$
 - 3) $x^3 - 9x^2 + 1$
 - 4) $x^4 - 9x^2 + 1$
- 23 In a given linear equation, the value of the independent variable decreases at a constant rate while the value of the dependent variable increases at a constant rate. The slope of this line is
- 1) positive
 - 2) negative
 - 3) zero
 - 4) undefined
- 24 The volume of a cylindrical can is 32π cubic inches. If the height of the can is 2 inches, what is its radius, in inches?
- 1) 8
 - 2) 2
 - 3) 16
 - 4) 4

25 The expression $\frac{14+x}{x^2-4}$ is undefined when x is

- 1) -14, only
- 2) 2, only
- 3) -2 or 2
- 4) -14, -2, or 2

26 What is the solution of $\frac{2}{x+1} = \frac{x+1}{2}$?

- 1) -1 and -3
- 2) -1 and 3
- 3) 1 and -3
- 4) 1 and 3

27 The total score in a football game was 72 points. The winning team scored 12 points more than the losing team. How many points did the winning team score?

- 1) 30
- 2) 42
- 3) 54
- 4) 60

28 What is the perimeter of the figure shown below, which consists of an isosceles trapezoid and a semicircle?

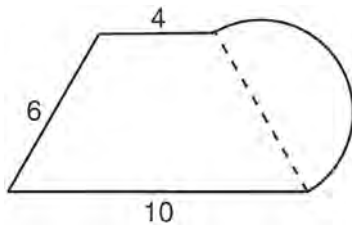

- 1) $20 + 3\pi$
- 2) $20 + 6\pi$
- 3) $26 + 3\pi$
- 4) $26 + 6\pi$

29 The probability it will rain tomorrow is $\frac{1}{2}$. The probability that our team will win tomorrow's basketball game is $\frac{3}{5}$. Which expression represents the probability that it will rain and that our team will *not* win the game?

- 1) $\frac{1}{2} + \frac{3}{5}$
- 2) $\frac{1}{2} + \frac{2}{5}$
- 3) $\frac{1}{2} \times \frac{3}{5}$
- 4) $\frac{1}{2} \times \frac{2}{5}$

30 The formula for the volume of a pyramid is $V = \frac{1}{3}Bh$. What is h expressed in terms of B and V ?

- 1) $h = \frac{1}{3}VB$
- 2) $h = \frac{V}{3B}$
- 3) $h = \frac{3V}{B}$
- 4) $h = 3VB$

31 State the value of the expression $\frac{(4.1 \times 10^2)(2.4 \times 10^3)}{(1.5 \times 10^7)}$ in scientific notation.

32 Express the product of $\frac{x+2}{2}$ and $\frac{4x+20}{x^2+6x+8}$ in simplest form.

- 33 On the set of axes below, graph $y = 3^x$ over the interval $-1 \leq x \leq 2$.

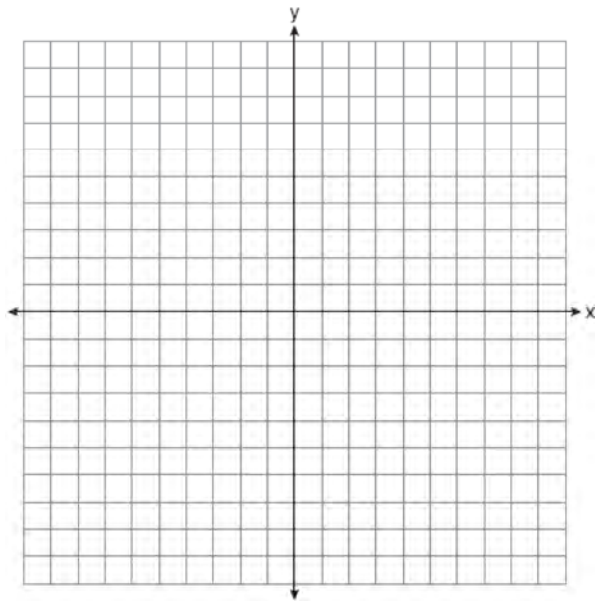

- 34 The following cumulative frequency histogram shows the distances swimmers completed in a recent swim test.

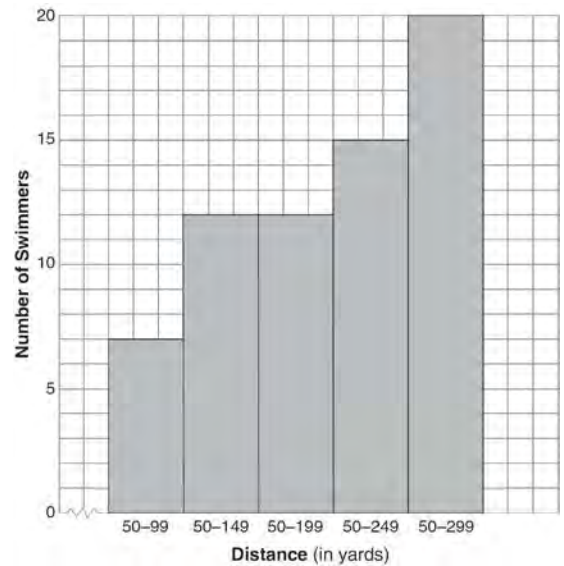

Based on the cumulative frequency histogram, determine the number of swimmers who swam between 200 and 249 yards. Determine the number of swimmers who swam between 150 and 199 yards. Determine the number of swimmers who took the swim test.

- 35 Ashley measured the dimensions of a rectangular prism to be 6 cm by 10 cm by 1.5 cm. The actual dimensions are 5.9 cm by 10.3 cm by 1.7 cm. Determine the relative error, to the *nearest thousandth*, in calculating the volume of the prism.

- 36 Solve the following system of equations algebraically for *all* values of x and y .

$$y = x^2 + 2x - 8$$

$$y = 2x + 1$$

37 A company is running a contest and offering a first, second, and third prize. First prize is a choice of a car or \$15,000 cash. Second prize is a choice of a motorbike, a trip to New York City, or \$2,000 cash. Third prize is a choice of a television or \$500 cash. If each prize is equally likely to be selected, list the sample space or draw a tree diagram of *all* possible different outcomes of first, second, and third prizes. Determine the number of ways that *all* three prizes selected could be cash. Determine the number of ways that *none* of the three prizes selected could be cash.

38 In right triangle ABC shown below, $AC = 29$ inches, $AB = 17$ inches, and $m\angle ABC = 90$. Find the number of degrees in the measure of angle BAC , to the *nearest degree*.

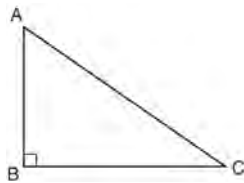

Find the length of \overline{BC} to the *nearest inch*.

39 On the set of axes below, graph the following system of inequalities.

$$y + x \geq 3$$

$$5x - 2y > 10$$

State the coordinates of *one* point that satisfies $y + x \geq 3$, but does *not* satisfy $5x - 2y > 10$.

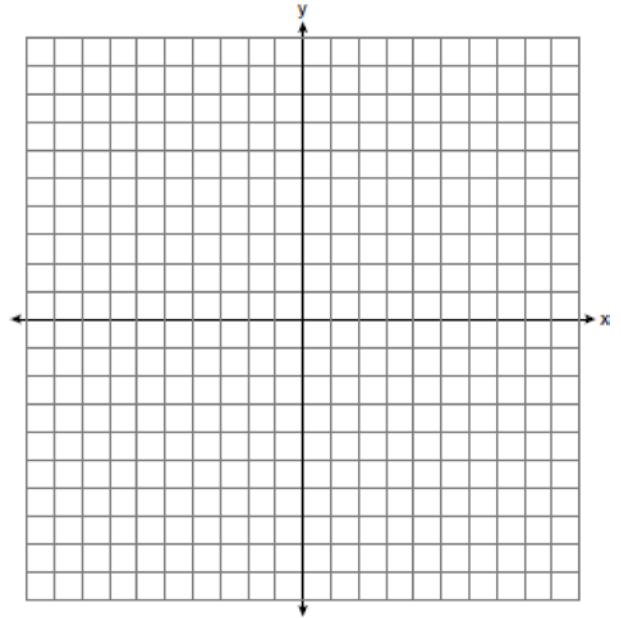

0113ia

- 1 The number of hours spent on math homework during one week and the math exam grades for eleven students in Ms. Smith’s algebra class are plotted below.

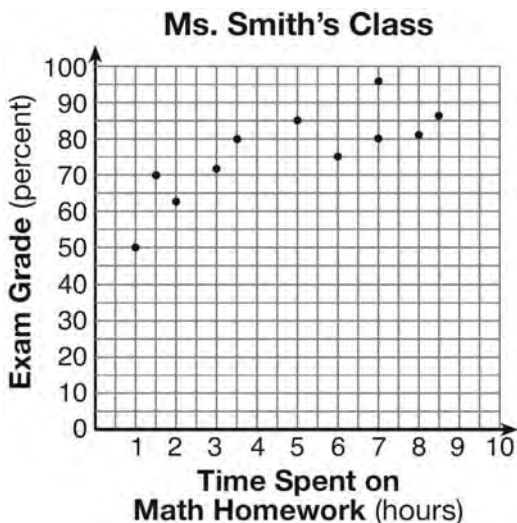

Based on the plotted data, what is the correlation between the time spent on homework and the exam grade?

- 1) positive
 - 2) negative
 - 3) no correlation
 - 4) cannot be determined
- 2 A car uses one gallon of gasoline for every 20 miles it travels. If a gallon of gasoline costs \$3.98, how much will the gas cost, to the nearest dollar, to travel 180 miles?
- 1) 9
 - 2) 36
 - 3) 45
 - 4) 80

- 3 If Angelina’s weekly allowance is d dollars, which expression represents her allowance, in dollars, for x weeks?

- 1) dx
- 2) $7dx$
- 3) $x + 7d$
- 4) $\frac{d}{x}$

- 4 What is the solution of the system of equations shown in the graph below?

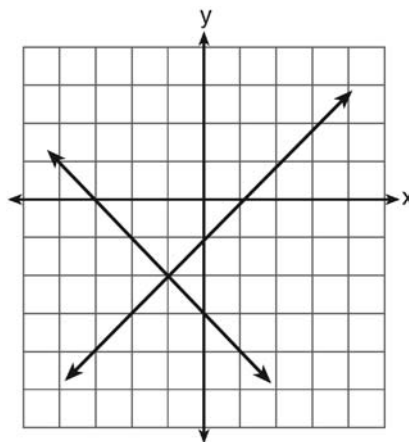

- 1) $(1, 0)$ and $(-3, 0)$
- 2) $(0, -3)$ and $(0, -1)$
- 3) $(-1, -2)$
- 4) $(-2, -1)$

- 5 The solution of the equation $5 - 2x = -4x - 7$ is

- 1) 1
- 2) 2
- 3) -2
- 4) -6

- 6 The expression $100n^2 - 1$ is equivalent to

- 1) $(10n + 1)(10n - 1)$
- 2) $(10n - 1)(10n - 1)$
- 3) $(50n + 1)(50n - 1)$
- 4) $(50n - 1)(50n - 1)$

- 7 In right triangle ABC shown below, what is the value of $\cos A$?

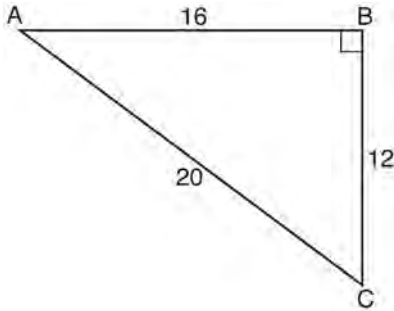

- 1) $\frac{12}{20}$
 2) $\frac{16}{20}$
 3) $\frac{20}{12}$
 4) $\frac{20}{16}$
- 8 A bag contains five green gumdrops and six red gumdrops. If Kim pulls a green gumdrop out of the bag and eats it, what is the probability that the next gumdrop she pulls out will be red?

- 1) $\frac{5}{11}$
 2) $\frac{5}{10}$
 3) $\frac{6}{11}$
 4) $\frac{6}{10}$

- 9 Which graph represents a function?

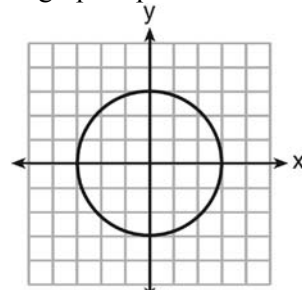

1)

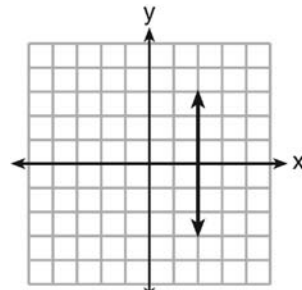

2)

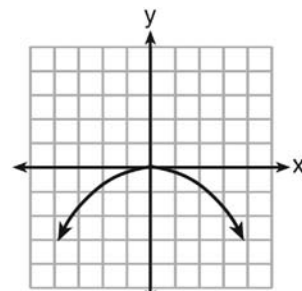

3)

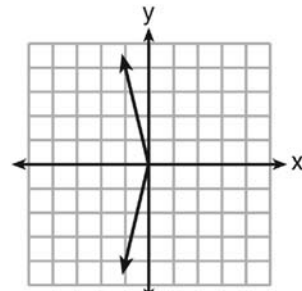

4)

- 10 The current population of a town is 10,000. If the population, P , increases by 20% each year, which equation could be used to find the population after t years?

- 1) $P = 10,000(0.2)^t$
 2) $P = 10,000(0.8)^t$
 3) $P = 10,000(1.2)^t$
 4) $P = 10,000(1.8)^t$

- 11 Which verbal expression is represented by $2(x + 4)$?
- 1) twice the sum of a number and four
 - 2) the sum of two times a number and four
 - 3) two times the difference of a number and four
 - 4) twice the product of a number and four

- 12 How many cubes with 5-inch sides will completely fill a cube that is 10 inches on a side?
- 1) 50
 - 2) 25
 - 3) 8
 - 4) 4

- 13 A school newspaper will survey students about the quality of the school's lunch program. Which method will create the *least* biased results?
- 1) Twenty-five vegetarians are randomly surveyed.
 - 2) Twenty-five students are randomly chosen from each grade level.
 - 3) Students who dislike the school's lunch program are chosen to complete the survey.
 - 4) A booth is set up in the cafeteria for the students to voluntarily complete the survey.

- 14 The vertex of the parabola $y = x^2 + 8x + 10$ lies in Quadrant
- 1) I
 - 2) II
 - 3) III
 - 4) IV

- 15 In the figure below, $ABCD$ is a square and semicircle O has a radius of 6.

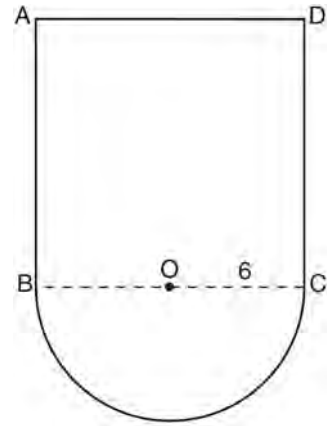

What is the area of the figure?

- 1) $36 + 6\pi$
 - 2) $36 + 18\pi$
 - 3) $144 + 18\pi$
 - 4) $144 + 36\pi$
- 16 What is $24x^2y^6 - 16x^6y^2 + 4xy^2$ divided by $4xy^2$?
- 1) $6xy^4 - 4x^5$
 - 2) $6xy^4 - 4x^5 + 1$
 - 3) $6x^2y^3 - 4x^6y$
 - 4) $6x^2y^3 - 4x^6y + 1$
- 17 Which expression can be used to change 75 kilometers per hour to meters per minute?
- 1) $\frac{75 \text{ km}}{1 \text{ hr}} \times \frac{1 \text{ km}}{1,000 \text{ m}} \times \frac{1 \text{ hr}}{60 \text{ min}}$
 - 2) $\frac{75 \text{ km}}{1 \text{ hr}} \times \frac{1 \text{ km}}{1,000 \text{ m}} \times \frac{60 \text{ min}}{1 \text{ hr}}$
 - 3) $\frac{75 \text{ km}}{1 \text{ hr}} \times \frac{1,000 \text{ m}}{1 \text{ km}} \times \frac{1 \text{ hr}}{60 \text{ min}}$
 - 4) $\frac{75 \text{ km}}{1 \text{ hr}} \times \frac{1,000 \text{ m}}{1 \text{ km}} \times \frac{60 \text{ min}}{1 \text{ hr}}$

- 18 The inequality $-2 \leq x \leq 3$ can be written as
- 1) $(-2, 3)$
 - 2) $[-2, 3)$
 - 3) $(-2, 3]$
 - 4) $[-2, 3]$

- 19 The expression $\frac{6 \times 10^{-7}}{3 \times 10^{-3}}$ is equivalent to
- 1) 2×10^4
 - 2) 2×10^{10}
 - 3) 2×10^{-4}
 - 4) 2×10^{-10}

- 20 The roots of the equation $x^2 - 14x + 48 = 0$ are
- 1) -6 and -8
 - 2) -6 and 8
 - 3) 6 and -8
 - 4) 6 and 8

- 21 If $x = -3$, what is the value of $|x - 4| - x^2$?
- 1) -8
 - 2) -2
 - 3) 7
 - 4) 16

- 22 Which equation represents a line that is parallel to the line whose equation is $2x - 3y = 9$?
- 1) $y = \frac{2}{3}x - 4$
 - 2) $y = -\frac{2}{3}x + 4$
 - 3) $y = \frac{3}{2}x - 4$
 - 4) $y = -\frac{3}{2}x + 4$

- 23 Which ordered pair is in the solution set of the system of inequalities $y \leq 3x + 1$ and $x - y > 1$?
- 1) $(-1, -2)$
 - 2) $(2, -1)$
 - 3) $(1, 2)$
 - 4) $(-1, 2)$

- 24 Which equation represents the line that passes through the point $(3, 4)$ and is parallel to the x -axis?
- 1) $x = 4$
 - 2) $x = -3$
 - 3) $y = 4$
 - 4) $y = -3$

- 25 A cube with faces numbered 1 through 6 is rolled 75 times, and the results are given in the table below.

Number	Frequency
1	7
2	22
3	14
4	6
5	20
6	6

Based on these results, which statement is true?

- 1) $P(\text{odd}) < P(\text{even})$
 - 2) $P(3 \text{ or less}) < P(\text{odd})$
 - 3) $P(\text{even}) < P(2 \text{ or } 4)$
 - 4) $P(2 \text{ or } 4) < P(3 \text{ or less})$
- 26 Given:
- $A = \{\text{perfect square integers from } 4\text{-}100, \text{ inclusive}\}$
- $B = \{16, 36, 49, 64\}$
- The complement of set B in the universal set A is
- 1) $\{9, 25, 81\}$
 - 2) $\{4, 9, 25, 81, 100\}$
 - 3) $\{1, 4, 9, 25, 81, 100\}$
 - 4) $\{4, 16, 36, 49, 64, 100\}$

27 The expression $\frac{2x^2 + 10x - 28}{4x + 28}$ is equivalent to

- 1) $\frac{x-2}{2}$
- 2) $x-1$
- 3) $\frac{x+2}{2}$
- 4) $\frac{x+5}{2}$

28 Which value of x is the solution of the equation

$$\frac{1}{7} + \frac{2x}{3} = \frac{15x-3}{21}?$$

- 1) 6
- 2) 0
- 3) $\frac{4}{13}$
- 4) $\frac{6}{29}$

29 Which statement is true about the data set 4, 5, 6, 6, 7, 9, 12?

- 1) mean = mode
- 2) mode = median
- 3) mean < median
- 4) mode > mean

30 How is the graph of $y = x^2 + 4x + 3$ affected when the coefficient of x^2 is changed to a smaller positive number?

- 1) The graph becomes wider, and the y -intercept changes.
- 2) The graph becomes wider, and the y -intercept stays the same.
- 3) The graph becomes narrower, and the y -intercept changes.
- 4) The graph becomes narrower, and the y -intercept stays the same.

31 Express $4\sqrt{75}$ in simplest radical form.

32 Factor completely: $5x^3 - 20x^2 - 60x$

33 On the set of axes below, graph $y = 2|x + 3|$. Include the interval $-7 \leq x \leq 1$.

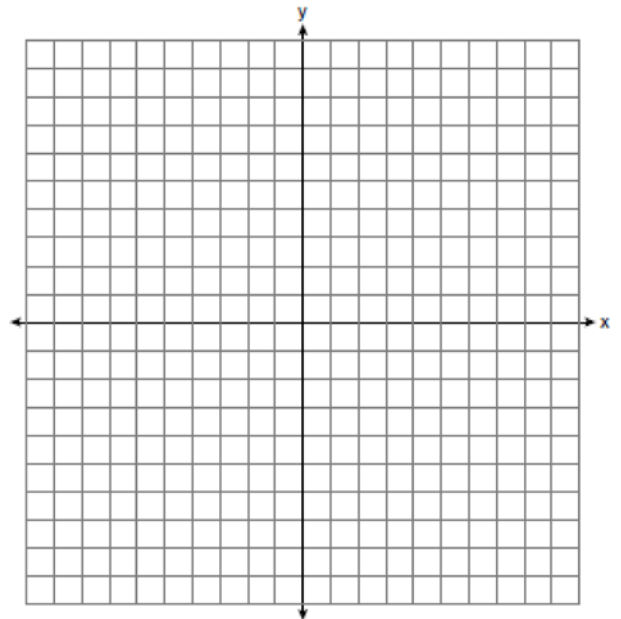

34 In a game, a player must spin each spinner shown in the diagram below once.

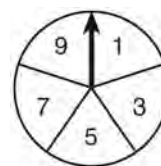

Spinner 1

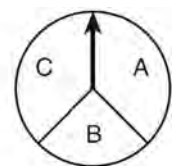

Spinner 2

Draw a tree diagram or list a sample space showing all possible outcomes. Determine the number of outcomes that consist of a prime number and a letter in the word "CAT."

35 The cost of three notebooks and four pencils is \$8.50. The cost of five notebooks and eight pencils is \$14.50. Determine the cost of one notebook and the cost of one pencil. [Only an algebraic solution can receive full credit.]

36 Wendy measures the floor in her rectangular bedroom for new carpeting. Her measurements are 24 feet by 14 feet. The actual measurements are 24.2 feet by 14.1 feet. Determine the relative error in calculating the area of her bedroom. Express your answer as a decimal to the *nearest thousandth*.

37 Using the line provided, construct a box-and-whisker plot for the 12 scores below.
26, 32, 19, 65, 57, 16, 28, 42, 40, 21, 38, 10



Determine the number of scores that lie above the 75th percentile.

38 A metal pipe is used to hold up a 9-foot fence, as shown in the diagram below. The pipe makes an angle of 48° with the ground.

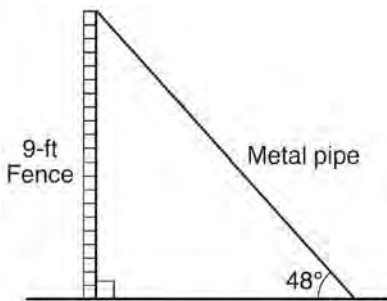

Determine, to the *nearest foot*, how far the bottom of the pipe is from the base of the fence.
Determine, to the *nearest foot*, the length of the metal pipe.

39 On the set of axes below, graph the following system of equations.

$$y + 2x = x^2 + 4$$

$$y - x = 4$$

Using the graph, determine and state the coordinates of *all* points in the solution set for the system of equations.

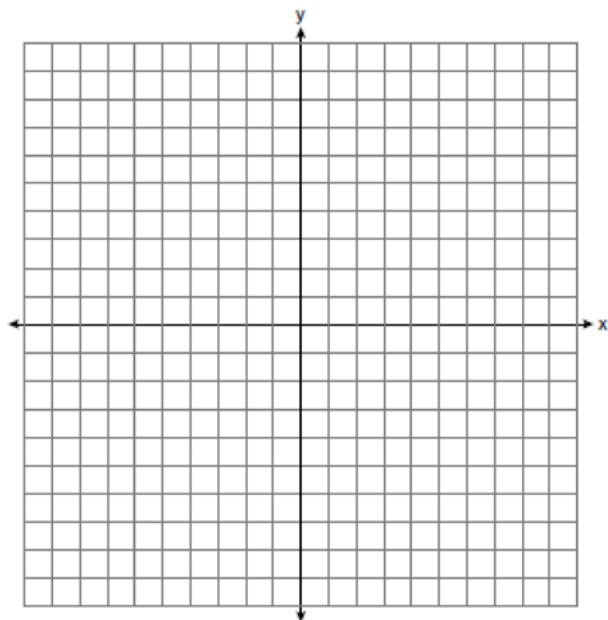

0613ia

- 1 Which expression represents “5 less than twice x ”?
- 1) $2x - 5$
 - 2) $5 - 2x$
 - 3) $2(5 - x)$
 - 4) $2(x - 5)$

- 2 Gabriella has 20 quarters, 15 dimes, 7 nickels, and 8 pennies in a jar. After taking 6 quarters out of the jar, what will be the probability of Gabriella randomly selecting a quarter from the coins left in the jar?

- 1) $\frac{14}{44}$
- 2) $\frac{30}{44}$
- 3) $\frac{14}{50}$
- 4) $\frac{20}{50}$

- 3 Based on the line of best fit drawn below, which value could be expected for the data in June 2015?

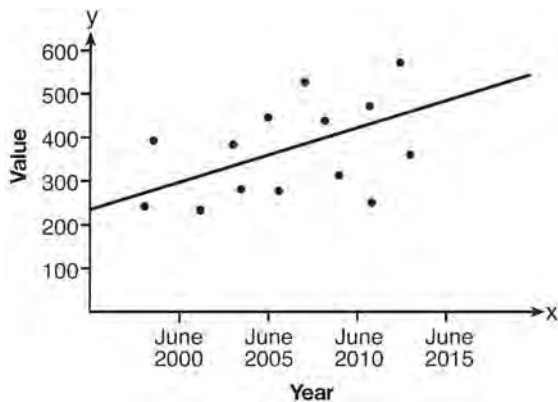

- 1) 230
- 2) 310
- 3) 480
- 4) 540

- 4 If the point $(5, k)$ lies on the line represented by the equation $2x + y = 9$, the value of k is

- 1) 1
- 2) 2
- 3) -1
- 4) -2

- 5 A soda container holds $5\frac{1}{2}$ gallons of soda. How many ounces of soda does this container hold?

1 quart = 32 ounces
1 gallon = 4 quarts

- 1) 44
- 2) 176
- 3) 640
- 4) 704

- 6 The roots of a quadratic equation can be found using the graph below.

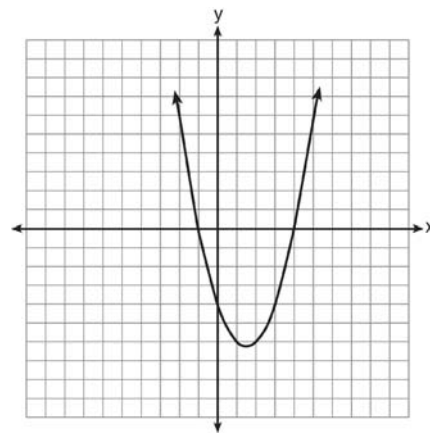

What are the roots of this equation?

- 1) -4, only
- 2) -4 and -1
- 3) -1 and 4
- 4) -4, -1, and 4

- 7 If the area of a rectangle is represented by $x^2 + 8x + 15$ and its length is represented by $x + 5$, which expression represents the width of the rectangle?
- 1) $x + 3$
 - 2) $x - 3$
 - 3) $x^2 + 6x + 5$
 - 4) $x^2 + 7x + 10$

- 8 Which set of data describes a situation that could be classified as qualitative?
- 1) the colors of the birds at the city zoo
 - 2) the shoe size of the zookeepers at the city zoo
 - 3) the heights of the giraffes at the city zoo
 - 4) the weights of the monkeys at the city zoo

- 9 The value of the expression $6! + \frac{5!(3!)}{4!} - 10$ is
- 1) 50
 - 2) 102
 - 3) 740
 - 4) 750

- 10 Which interval notation represents $-3 \leq x \leq 3$?
- 1) $[-3, 3]$
 - 2) $(-3, 3]$
 - 3) $[-3, 3)$
 - 4) $(-3, 3)$

- 11 The solutions of $x^2 = 16x - 28$ are
- 1) -2 and -14
 - 2) 2 and 14
 - 3) -4 and -7
 - 4) 4 and 7

- 12 If the expression $(2y^a)^4$ is equivalent to $16y^8$, what is the value of a ?
- 1) 12
 - 2) 2
 - 3) 32
 - 4) 4

- 13 Which table shows bivariate data?

1)

Age (yr)	Frequency
14	12
15	21
16	14
17	19
18	15

2)

Type of Car	Average Gas Mileage (mpg)
van	25
SUV	23
luxury	26
compact	28
pickup	22

3)

Time Spent Studying (hr)	Test Grade (%)
1	65
2	72
3	83
4	85
5	92

4)

Day	Temperature (degrees F)
Monday	63
Tuesday	58
Wednesday	72
Thursday	74
Friday	78

- 14 The box-and-whisker plot below represents the results of tests scores in a math class.

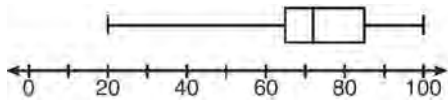

What do the scores 65, 85, and 100 represent?

- 1) Q_1 , median, Q_3
 - 2) Q_1 , Q_3 , maximum
 - 3) median, Q_1 , maximum
 - 4) minimum, median, maximum
- 15 The expression $\frac{x-3}{x+2}$ is undefined when the value

- of x is
- 1) -2 , only
 - 2) -2 and 3
 - 3) 3 , only
 - 4) -3 and 2

- 16 If $rx - st = r$, which expression represents x ?

- 1) $\frac{r+st}{r}$
- 2) $\frac{r}{r+st}$
- 3) $\frac{r}{r-st}$
- 4) $\frac{r-st}{r}$

- 17 What is the solution of the equation $\frac{x+2}{2} = \frac{4}{x}$?

- 1) 1 and -8
- 2) 2 and -4
- 3) -1 and 8
- 4) -2 and 4

- 18 Which type of function is graphed below?

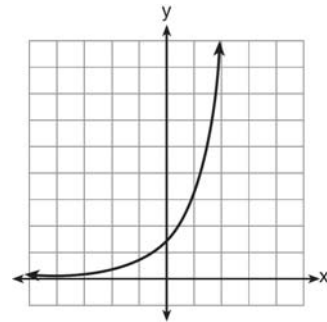

- 1) linear
 - 2) quadratic
 - 3) exponential
 - 4) absolute value
- 19 What is the slope of the line represented by the equation $4x + 3y = 12$?

- 1) $\frac{4}{3}$
- 2) $\frac{3}{4}$
- 3) $-\frac{3}{4}$
- 4) $-\frac{4}{3}$

- 20 The diagram below shows the graph of which inequality?

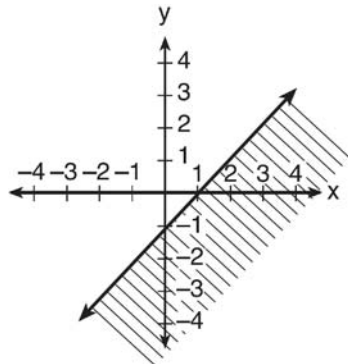

- 1) $y > x - 1$
 2) $y \geq x - 1$
 3) $y < x - 1$
 4) $y \leq x - 1$
- 21 Carol plans to sell twice as many magazine subscriptions as Jennifer. If Carol and Jennifer need to sell at least 90 subscriptions in all, which inequality could be used to determine how many subscriptions, x , Jennifer needs to sell?

- 1) $x \geq 45$
 2) $2x \geq 90$
 3) $2x - x \geq 90$
 4) $2x + x \geq 90$
- 22 When $2x^2 - 3x + 2$ is subtracted from $4x^2 - 5x + 2$, the result is

- 1) $2x^2 - 2x$
 2) $-2x^2 + 2x$
 3) $-2x^2 - 8x + 4$
 4) $2x^2 - 8x + 4$

- 23 Which expression represents the number of hours in w weeks and d days?

- 1) $7w + 12d$
 2) $84w + 24d$
 3) $168w + 24d$
 4) $168w + 60d$

- 24 Given: $R = \{1, 2, 3, 4\}$

$A = \{0, 2, 4, 6\}$

$P = \{1, 3, 5, 7\}$

What is $R \cap P$?

- 1) $\{0, 1, 2, 3, 4, 5, 6, 7\}$
 2) $\{1, 2, 3, 4, 5, 7\}$
 3) $\{1, 3\}$
 4) $\{2, 4\}$

- 25 Which equation could be used to find the measure of angle D in the right triangle shown in the diagram below?

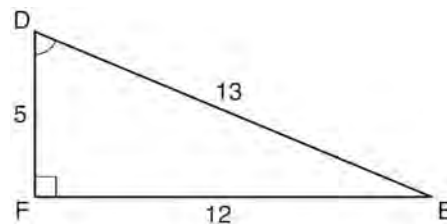

- 1) $\cos D = \frac{12}{13}$
 2) $\cos D = \frac{13}{12}$
 3) $\sin D = \frac{5}{13}$
 4) $\sin D = \frac{12}{13}$

- 26 If the roots of a quadratic equation are -2 and 3 , the equation can be written as
- 1) $(x - 2)(x + 3) = 0$
 - 2) $(x + 2)(x - 3) = 0$
 - 3) $(x + 2)(x + 3) = 0$
 - 4) $(x - 2)(x - 3) = 0$
- 27 Which equation represents a line that is parallel to the y -axis and passes through the point $(4, 3)$?
- 1) $x = 3$
 - 2) $x = 4$
 - 3) $y = 3$
 - 4) $y = 4$
- 28 There are 18 students in a class. Each day, the teacher randomly selects three students to assist in a game: a leader, a recorder, and a timekeeper. In how many possible ways can the jobs be assigned?
- 1) 306
 - 2) 816
 - 3) 4896
 - 4) 5832
- 29 In triangle RST , angle R is a right angle. If $TR = 6$ and $TS = 8$, what is the length of RS ?
- 1) 10
 - 2) 2
 - 3) $2\sqrt{7}$
 - 4) $7\sqrt{2}$
- 30 How many solutions are there for the following system of equations?
- $$y = x^2 - 5x + 3$$
- $$y = x - 6$$
- 1) 1
 - 2) 2
 - 3) 3
 - 4) 0

- 31 Solve the inequality $-5(x - 7) < 15$ algebraically for x .
- 32 Oatmeal is packaged in a cylindrical container, as shown in the diagram below.

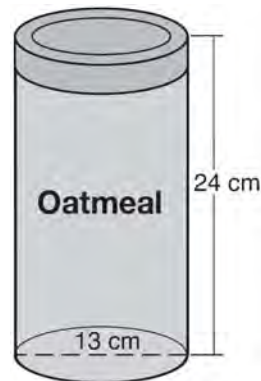

The diameter of the container is 13 centimeters and its height is 24 centimeters. Determine, in terms of π , the volume of the cylinder, in cubic centimeters.

- 33 The distance from Earth to Mars is 136,000,000 miles. A spaceship travels at 31,000 miles per hour. Determine, to the *nearest day*, how long it will take the spaceship to reach Mars.

- 34 The menu for the high school cafeteria is shown below.

Main Course	Vegetable	Dessert	Beverage
veggie burger	corn	gelatin	milk
pizza	green beans	fruit salad	juice
tuna sandwich	carrots	yogurt	bottled water
frankfurter		cookie	
chicken tenders		ice cream cup	

Determine the number of possible meals consisting of a main course, a vegetable, a dessert, and a beverage that can be selected from the menu.

Determine how many of these meals will include chicken tenders. If a student chooses pizza, corn or carrots, a dessert, and a beverage from the menu, determine the number of possible meals that can be selected.

- 35 A man standing on level ground is 1000 feet away from the base of a 350-foot-tall building. Find, to the *nearest degree*, the measure of the angle of elevation to the top of the building from the point on the ground where the man is standing.

- 36 Express $\sqrt{25} - 2\sqrt{3} + \sqrt{27} + 2\sqrt{9}$ in simplest radical form.

- 37 Solve algebraically: $\frac{2}{3x} + \frac{4}{x} = \frac{7}{x+1}$

[Only an algebraic solution can receive full credit.]

- 38 A jar contains five red marbles and three green marbles. A marble is drawn at random and not replaced. A second marble is then drawn from the jar. Find the probability that the first marble is red and the second marble is green. Find the probability that both marbles are red. Find the probability that both marbles are the same color.

- 39 In the diagram below of rectangle $AFEB$ and a semicircle with diameter \overline{CD} , $AB = 5$ inches, $AB = BC = DE = FE$, and $CD = 6$ inches. Find the area of the shaded region, to the *nearest hundredth of a square inch*.

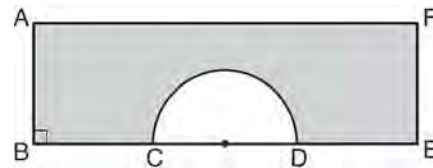

0813ia

- 1 Which situation describes a negative correlation?
- 1) the amount of gas left in a car's tank and the amount of gas used from it
 - 2) the number of gallons of gas purchased and the amount paid for the gas
 - 3) the size of a car's gas tank and the number of gallons it holds
 - 4) the number of miles driven and the amount of gas used
- 2 The sum of $8n^2 - 3n + 10$ and $-3n^2 - 6n - 7$ is
- 1) $5n^2 - 9n + 3$
 - 2) $5n^2 - 3n - 17$
 - 3) $-11n^2 - 9n - 17$
 - 4) $-11n^2 - 3n + 3$
- 3 Which event is certain to happen?
- 1) Everyone walking into a room will have red hair.
 - 2) All babies born in June will be males.
 - 3) The Yankees baseball team will win the World Series.
 - 4) The Sun will rise in the east.
- 4 Noj is 5 years older than Jacob. The product of their ages is 84. How old is Noj?
- 1) 6
 - 2) 7
 - 3) 12
 - 4) 14
- 5 Marie currently has a collection of 58 stamps. If she buys s stamps each week for w weeks, which expression represents the total number of stamps she will have?
- 1) $58sw$
 - 2) $58 + sw$
 - 3) $58s + w$
 - 4) $58 + s + w$
- 6 Given:
 $A = \{\text{all odd integers from 1 through 19, inclusive}\}$
 $B = \{9, 11, 13, 15, 17\}$
What is the complement of set B within set A ?
- 1) $\{3, 5, 7\}$
 - 2) $\{3, 5, 7, 19\}$
 - 3) $\{1, 3, 5, 7\}$
 - 4) $\{1, 3, 5, 7, 19\}$
- 7 Which equation represents a line that is parallel to the line whose equation is $y = -3x - 7$?
- 1) $y = -3x + 4$
 - 2) $y = -\frac{1}{3}x - 7$
 - 3) $y = \frac{1}{3}x + 5$
 - 4) $y = 3x - 2$

- 8 Which graph does *not* represent the graph of a function?

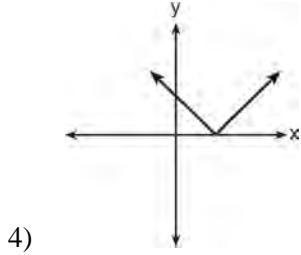
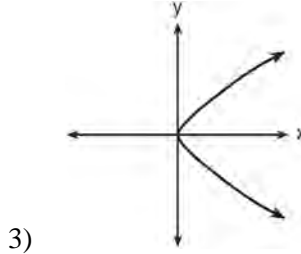
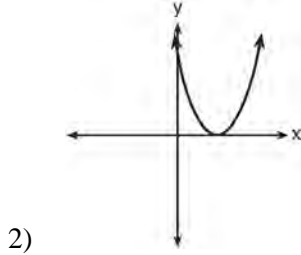
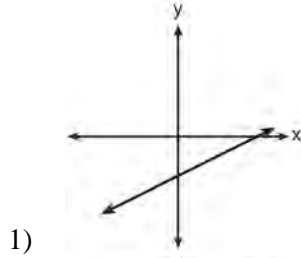

- 9 Which value of x is in the solution set of $-3x + 8 \geq 14$?

- 1) -3
- 2) -1
- 3) 0
- 4) 3

- 10 What is the slope of the line that passes through the points $(4, -7)$ and $(9, 1)$?

- 1) $\frac{5}{8}$
- 2) $\frac{8}{5}$
- 3) $-\frac{6}{12}$
- 4) $-\frac{13}{6}$

- 11 The product of $\frac{4x^2}{7y^2}$ and $\frac{21y^3}{20x^4}$, expressed in simplest form, is

- 1) $0.6x^2y$
- 2) $\frac{3y}{5x^2}$
- 3) $\frac{12x^2y^3}{20x^4y^2}$
- 4) $\frac{84x^2y^3}{140x^4y^2}$

- 12 The box-and-whisker plot below represents a set of grades in a college statistics class.

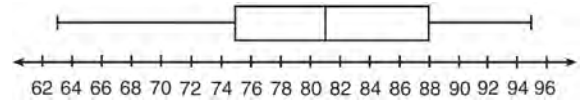

Which interval contains exactly 50% of the grades?

- 1) 63-88
- 2) 63-95
- 3) 75-81
- 4) 75-88

13 An art studio has a list of information posted with each sculpture that is for sale. Each entry in the list could be classified as quantitative *except* for the

- 1) cost
- 2) height
- 3) artist
- 4) weight

14 Which graph represents the inequality $y \geq x + 3$?

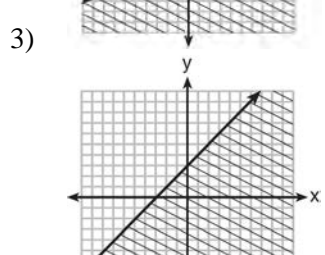
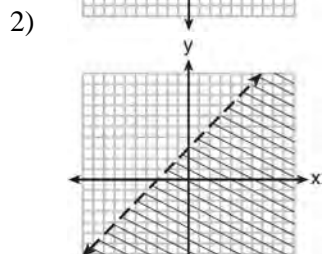
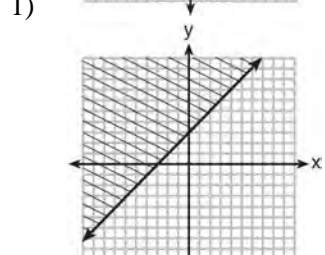
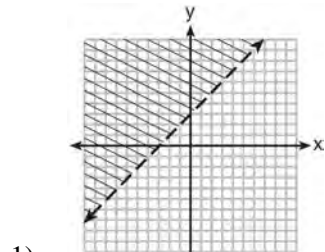

15 Using the substitution method, Ken solves the following system of equations algebraically.

$$2x - y = 5$$

$$3x + 2y = -3$$

Which equivalent equation could Ken use?

- 1) $3x + 2(2x - 5) = -3$
- 2) $3x + 2(5 - 2x) = -3$
- 3) $3\left(y + \frac{5}{2}\right) + 2y = -3$
- 4) $3\left(\frac{5}{2} - y\right) + 2y = -3$

16 A value of x that makes the expression

$$\frac{x^2 + 4x - 12}{x^2 - 2x - 15}$$

undefined is

- 1) -6
- 2) -2
- 3) 3
- 4) 5

17 The statement $|-15| < x < |-20|$ is true when x is equal to

- 1) -16
- 2) -14
- 3) 17
- 4) 21

18 Which equation is true?

- 1) $\frac{c^5}{d^7} \div \frac{d^3}{c} = \frac{c^4}{d^4}$
- 2) $(-2m^2p)^3 = -8m^6p^3$
- 3) $\left(\frac{s^3t^8}{s^4t^5}\right)^2 = \frac{t^5}{s^2}$
- 4) $(-2a^2b^3)(3ab^2) = a^3b^5$

- 19 The equation $3(4x) = (4x)3$ illustrates which property?
- 1) commutative
 - 2) associative
 - 3) distributive
 - 4) multiplicative inverse
- 20 Monique has three sons who play football, two sons who play baseball, and one son who plays both sports. If all of her sons play baseball or football, how many sons does she have?
- 1) 5
 - 2) 6
 - 3) 3
 - 4) 4
- 21 Written in set-builder notation, $S = \{1, 3, 5, 7, 9\}$ is
- 1) $\{x | 1 < x < 9, \text{ where } x \text{ is a prime number}\}$
 - 2) $\{x | 1 \leq x \leq 9, \text{ where } x \text{ is a prime number}\}$
 - 3) $\{x | 1 < x < 9, \text{ where } x \text{ is an odd integer}\}$
 - 4) $\{x | 1 \leq x \leq 9, \text{ where } x \text{ is an odd integer}\}$
- 22 Which is the equation of a parabola that has the same vertex as the parabola represented by $y = x^2$, but is wider?
- 1) $y = x^2 + 2$
 - 2) $y = x^2 - 2$
 - 3) $y = 2x^2$
 - 4) $y = \frac{1}{2}x^2$
- 23 In right triangle ABC , $m\angle C = 90$, $AC = 7$, and $AB = 13$. What is the length of BC ?
- 1) 6
 - 2) 20
 - 3) $\sqrt{120}$
 - 4) $\sqrt{218}$
- 24 A cube, with faces numbered 1 to 6, is rolled, and a penny is tossed at the same time. How many elements in the sample space consist of an even number and a tail?
- 1) 12
 - 2) 2
 - 3) 3
 - 4) 4
- 25 If the volume of a cube is 8 cubic centimeters, what is its surface area, in square centimeters?
- 1) 32
 - 2) 24
 - 3) 12
 - 4) 4

- 26 A designer created a garden, as shown in the diagram below. The garden consists of four quarter-circles of equal size inside a square. The designer put a fence around both the inside and the outside of the garden.

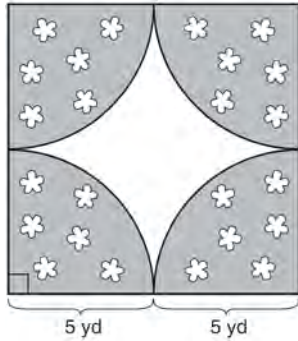

Which expression represents the amount of fencing, in yards, that the designer used for the fence?

- 1) $40 + 10\pi$
 - 2) $40 + 25\pi$
 - 3) $100 + 10\pi$
 - 4) $100 + 25\pi$
- 27 Mr. Taylor raised all his students' scores on a recent test by five points. How were the mean and the range of the scores affected?
- 1) The mean increased by five and the range increased by five.
 - 2) The mean increased by five and the range remained the same.
 - 3) The mean remained the same and the range increased by five.
 - 4) The mean remained the same and the range remained the same.

- 28 Which fraction is equivalent to $\frac{4}{3a} - \frac{5}{2a}$?

- 1) $-\frac{1}{a}$
- 2) $-\frac{1}{5a}$
- 3) $-\frac{7}{6a}$
- 4) $-\frac{7}{6a^2}$

- 29 Which ratio represents the cosine of angle A in the right triangle below?

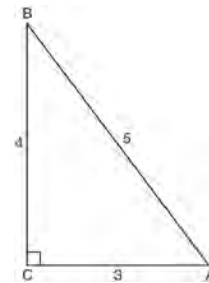

- 1) $\frac{3}{5}$
 - 2) $\frac{5}{3}$
 - 3) $\frac{4}{5}$
 - 4) $\frac{4}{3}$
- 30 If $2y + 2w = x$, then w , in terms of x and y , is equal to
- 1) $x - y$
 - 2) $\frac{x - 2y}{2}$
 - 3) $x + y$
 - 4) $\frac{x + 2y}{2}$

- 31 A jogger ran at a rate of 5.4 miles per hour. Find the jogger's *exact* rate, in feet per minute.

1 mile = 5,280 feet

- 32 Express $2\sqrt{108}$ in simplest radical form.
- 33 Adrienne invested \$2000 in an account at a 3.5% interest rate compounded annually. She made no deposits or withdrawals on the account for 4 years. Determine, to the *nearest dollar*, the balance in the account after the 4 years.
- 34 Miller's Department Store is having a sale with a 25% discount on mattresses. If the sales tax rate is 8%, how much change will Frank receive from \$800 if he purchases a mattress regularly priced at \$895 during this sale?
- 35 The difference between two numbers is 28. The larger number is 8 less than twice the smaller number. Find *both* numbers. [Only an algebraic solution can receive full credit.]
- 36 Janis measures the dimensions of the floor in her rectangular classroom for a rug. Her measurements are 10.50 feet by 12.25 feet. The actual measurements of the floor are 10.75 feet by 12.50 feet. Determine the relative error in calculating the area, to the *nearest thousandth*.

- 37 On the set of axes below, graph the following system of equations. Using the graph, determine and state *all* solutions of the system of equations.

$$y = -x^2 - 2x + 3$$

$$y + 1 = -2x$$

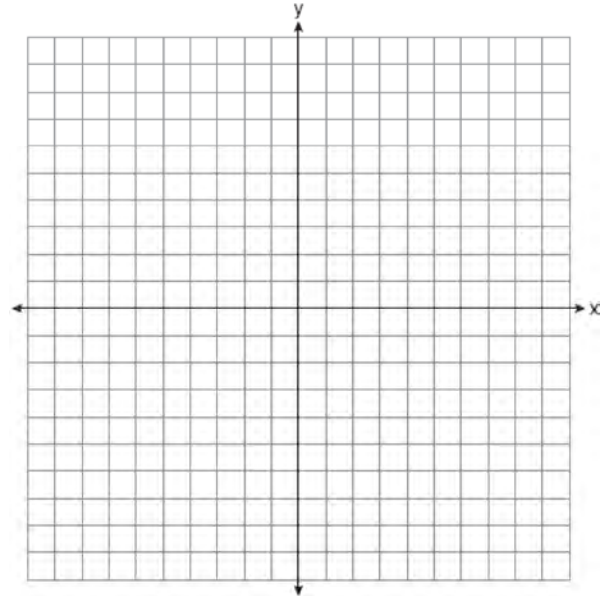

- 38 Express $\frac{3x^2 + 9x}{x^2 + 5x + 6} \div \frac{x^2 - 9}{x^2 - x - 6}$ in simplest form.
- 39 A bottle contains 12 red marbles and 8 blue marbles. A marble is chosen at random and not replaced. Then, a second marble is chosen at random. Determine the probability that the two marbles are *not* the same color. Determine the probability that *at least* one of the marbles is red.

0114ia

- 1 An example of an equation is
 - 1) $2x^2 - 4x + 12$
 - 2) $|x - 6|$
 - 3) $4(x + 6)(x - 2)$
 - 4) $2x = x^2 + 3$

- 2 The greatest common factor of $3m^2n + 12mn^2$ is?
 - 1) $3n$
 - 2) $3m$
 - 3) $3mn$
 - 4) $3mn^2$

- 3 Jeremy is hosting a Halloween party for 80 children. He will give each child *at least* one candy bar. If each bag of candy contains 18 candy bars, which inequality can be used to determine how many bags, c , Jeremy will need to buy?
 - 1) $18c \geq 80$
 - 2) $18c \leq 80$
 - 3) $\frac{c}{18} \geq 80$
 - 4) $\frac{c}{18} \leq 80$

- 4 Which statement regarding biased sampling is *false*?
 - 1) Online sampling is biased because only the people who happen to visit the web site will take the survey.
 - 2) A radio call-in survey is biased because only people who feel strongly about the topic will respond.
 - 3) A survey handed to every third person leaving a library is biased because everyone leaving the library was not asked to participate.
 - 4) Asking for experts to take a survey is biased because they may have particular knowledge of the topic.

- 5 Which relation is *not* a function?
 - 1) $\{(2, 4), (1, 2), (0, 0), (-1, 2), (-2, 4)\}$
 - 2) $\{(2, 4), (1, 1), (0, 0), (-1, 1), (-2, 4)\}$
 - 3) $\{(2, 2), (1, 1), (0, 0), (-1, 1), (-2, 2)\}$
 - 4) $\{(2, 2), (1, 1), (0, 0), (1, -1), (2, -2)\}$

- 6 What is an equation of the line that passes through the point $(-2, -8)$ and has a slope of 3?
 - 1) $y = 3x - 2$
 - 2) $y = 3x - 22$
 - 3) $y = 3x + 2$
 - 4) $y = 3x + 22$

- 7 A figure consists of a square and a semicircle, as shown in the diagram below.

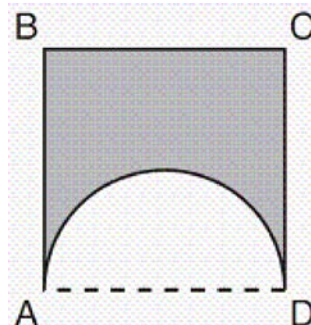

If the length of a side of the square is 6, what is the area of the shaded region?

- 1) $36 - 3\pi$
- 2) $36 - 4.5\pi$
- 3) $36 - 6\pi$
- 4) $36 - 9\pi$

- 8 The box-and-whisker plot shown below represents the number of magazine subscriptions sold by members of a club.

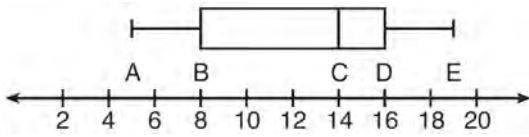

Which statistical measures do points B , D , and E represent, respectively?

- 1) minimum, median, maximum
 - 2) first quartile, median, third quartile
 - 3) first quartile, third quartile, maximum
 - 4) median, third quartile, maximum
- 9 What is the slope of a line represented by the equation $2y = x - 4$?
- 1) 1
 - 2) $\frac{1}{2}$
 - 3) -1
 - 4) $-\frac{1}{2}$

- 10 What is the solution of the system of equations below?

$$\begin{aligned} 2x + 3y &= 7 \\ x + y &= 3 \end{aligned}$$

- 1) (1, 2)
- 2) (2, 1)
- 3) (4, -1)
- 4) (4, 1)

- 11 The graph below illustrates the number of acres used for farming in Smalltown, New York, over several years.

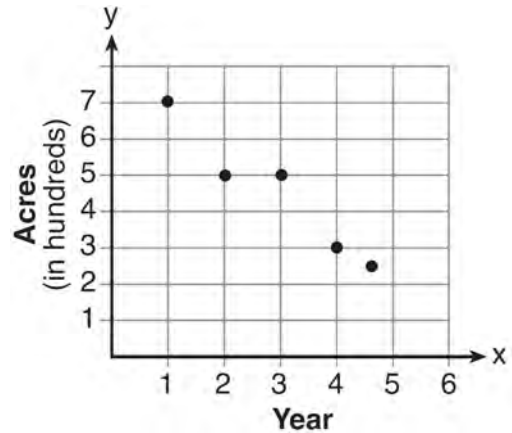

Using a line of best fit, approximately how many acres will be used for farming in the 5th year?

- 1) 0
 - 2) 200
 - 3) 300
 - 4) 400
- 12 When $16x^3 - 12x^2 + 4x$ is divided by $4x$, the quotient is
- 1) $12x^2 - 8x$
 - 2) $12x^2 - 8x + 1$
 - 3) $4x^2 - 3x$
 - 4) $4x^2 - 3x + 1$
- 13 The width of a rectangle is 4 less than half the length. If ℓ represents the length, which equation could be used to find the width, w ?
- 1) $w = \frac{1}{2}(4 - \ell)$
 - 2) $w = \frac{1}{2}(\ell - 4)$
 - 3) $w = \frac{1}{2}\ell - 4$
 - 4) $w = 4 - \frac{1}{2}\ell$

- 14 Which data can be classified as quantitative?
- 1) favorite stores at which you shop
 - 2) U.S. Representatives and their home states
 - 3) sales tax rate in each New York county
 - 4) opinion of a freshman on the color of Paul's shirt
- 15 Two cubes with sides numbered 1 through 6 were rolled 20 times. Their sums are recorded in the table below.

4	9	8	9	2
9	4	6	12	10
8	7	9	11	10
8	7	9	3	5

What is the empirical probability of rolling a sum of 9?

- 1) $\frac{4}{20}$
 - 2) $\frac{5}{20}$
 - 3) $\frac{4}{36}$
 - 4) $\frac{5}{36}$
- 16 What is the vertex of the graph of the equation $y = 3x^2 + 6x + 1$?
- 1) $(-1, -2)$
 - 2) $(-1, 10)$
 - 3) $(1, -2)$
 - 4) $(1, 10)$
- 17 The length and width of a rectangle are 48 inches and 40 inches. To the *nearest inch*, what is the length of its diagonal?
- 1) 27
 - 2) 62
 - 3) 88
 - 4) 90

- 18 Which graph represents the solution set of $2x - 5 < 3$?

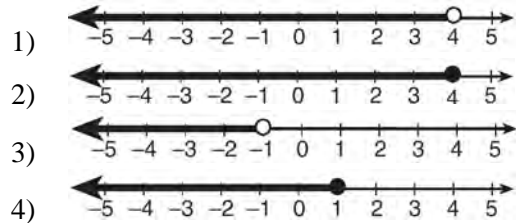

- 19 Jonathan drove to the airport to pick up his friend. A rainstorm forced him to drive at an average speed of 45 mph, reaching the airport in 3 hours. He drove back home at an average speed of 55 mph. How long, to the nearest tenth of an hour, did the trip home take him?
- 1) 2.0 hours
 - 2) 2.5 hours
 - 3) 2.8 hours
 - 4) 3.7 hours
- 20 The expression $\frac{2n}{5} + \frac{3n}{2}$ is equivalent to
- 1) $\frac{5n}{7}$
 - 2) $\frac{6n^2}{10}$
 - 3) $\frac{19n}{10}$
 - 4) $\frac{7n}{10}$
- 21 When $x = 4$, the value of $2x^0 + x!$ is
- 1) 24
 - 2) 25
 - 3) 26
 - 4) 28

22 Which graph represents the solution of $2y + 6 > 4x$?

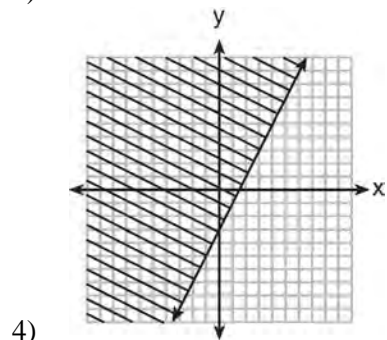
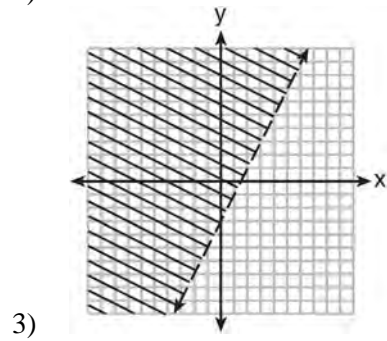
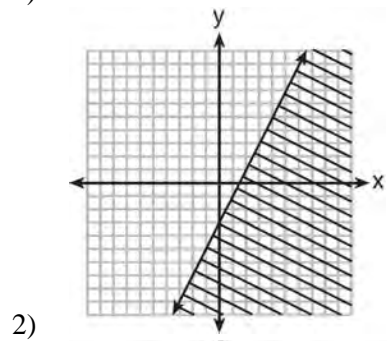
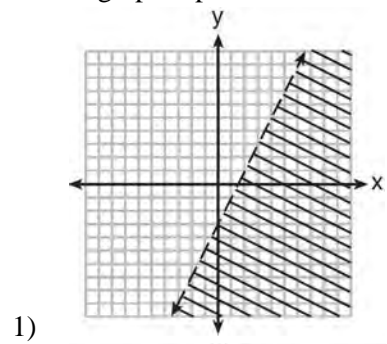

23 Which graph represents the exponential decay of a radioactive element?

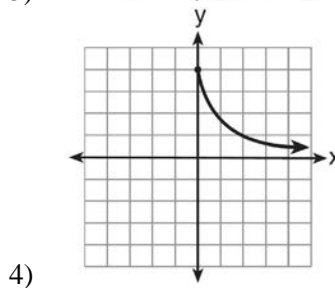
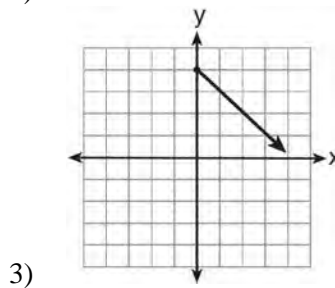
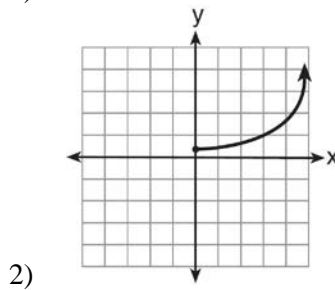
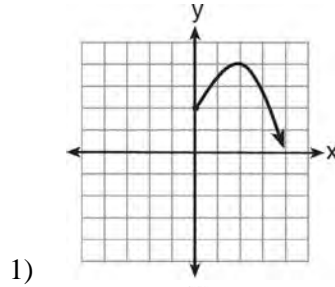

24 Which fraction represents $\frac{x^2 - 25}{x^2 - x - 20}$ expressed in simplest form?

- 1) $\frac{5}{4}$
- 2) $\frac{x - 5}{x - 4}$
- 3) $\frac{x + 5}{x + 4}$
- 4) $\frac{25}{x + 20}$

25 If $abx - 5 = 0$, what is x in terms of a and b ?

- 1) $x = \frac{5}{ab}$
- 2) $x = -\frac{5}{ab}$
- 3) $x = 5 - ab$
- 4) $x = ab - 5$

26 Given: $U = \{x | 0 < x < 10 \text{ and } x \text{ is an integer}\}$

$S = \{x | 0 < x < 10 \text{ and } x \text{ is an odd integer}\}$

The complement of set S within the universal set U is

- 1) $\{0, 2, 4, 6, 8, 10\}$
- 2) $\{2, 4, 6, 8, 10\}$
- 3) $\{0, 2, 4, 6, 8\}$
- 4) $\{2, 4, 6, 8\}$

27 The roots of the equation $2x^2 - 8x = 0$ are

- 1) -2 and 2
- 2) $0, -2$ and 2
- 3) 0 and -4
- 4) 0 and 4

28 Which equation illustrates the multiplicative inverse property?

- 1) $a \cdot 1 = a$
- 2) $a \cdot 0 = 0$
- 3) $a\left(\frac{1}{a}\right) = 1$
- 4) $(-a)(-a) = a^2$

29 What is the result when $4x^2 - 17x + 36$ is subtracted from $2x^2 - 5x + 25$?

- 1) $6x^2 - 22x + 61$
- 2) $2x^2 - 12x + 11$
- 3) $-2x^2 - 22x + 61$
- 4) $-2x^2 + 12x - 11$

30 Julie has three children whose ages are consecutive odd integers. If x represents the youngest child's age, which expression represents the sum of her children's ages?

- 1) $3x + 3$
- 2) $3x + 4$
- 3) $3x + 5$
- 4) $3x + 6$

31 Express $\frac{\sqrt{84}}{2\sqrt{3}}$ in simplest radical form.

32 The cumulative frequency table below shows the number of minutes 31 students spent text messaging on a weekend.

Text-Use Interval (minutes)	Cumulative Frequency
41–50	2
41–60	5
41–70	10
41–80	19
41–90	31

Determine which 10-minute interval contains the median. Justify your choice.

33 Kirsten invested \$1000 in an account at an annual interest rate of 3%. She made no deposits or withdrawals on the account for 5 years. The interest was compounded annually. Find the balance in the account, to the *nearest cent*, at the end of 5 years.

- 34 Graph and label the functions $y = |x|$ and $y = |2x|$ on the set of axes below.

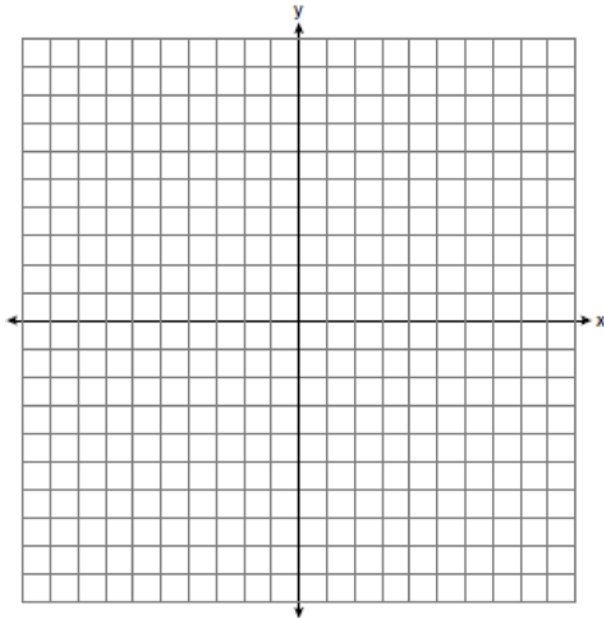

Explain how increasing the coefficient of x affects the graph of $y = |x|$.

- 35 Terry estimated the length of the edge of a cube to be 5 cm. The actual length of the side is 5.2 cm. Find the relative error of the surface area of the cube, to the *nearest thousandth*.

- 36 From the top of an apartment building, the angle of depression to a car parked on the street below is 38 degrees, as shown in the diagram below. The car is parked 80 feet from the base of the building. Find the height of the building, to the *nearest tenth of a foot*.

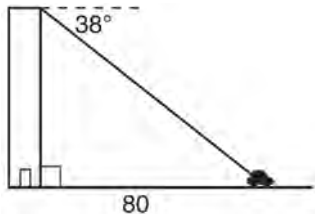

- 37 On the set of axes below, solve the following system of equations graphically for all values of x and y . State the coordinates of all solutions.

$$y = x^2 + 4x - 5$$

$$y = 2x + 3$$

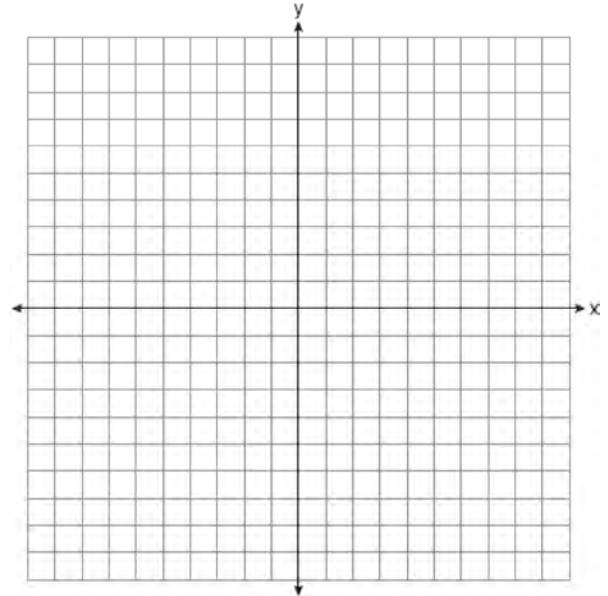

- 38 Solve algebraically for all values of x :

$$\frac{3}{x+5} = \frac{2x}{x^2 - 8}$$

- 39 Doug has four baseball caps: one tan, one blue, one red, and one green. He also has three jackets: one blue, one red, and one white. Draw a tree diagram or list a sample space to show all possible outfits consisting of one baseball cap and one jacket. Find the number of Doug's outfits that consist of a cap and a jacket that are different colors. On Spirit Day, Doug wants to wear either green or white, his school's colors. Find the number of his outfits from which he can choose.

fall07ia

Answer Section

- 1 ANS: 2 PTS: 2 REF: fall0701ia STA: A.S.7
TOP: Scatter Plots
- 2 ANS: 3 PTS: 2 REF: fall0702ia STA: A.S.23
TOP: Theoretical Probability KEY: mutually exclusive events
- 3 ANS: 3
$$\frac{(2x^3)(8x^5)}{4x^6} = \frac{16x^8}{4x^6} = 4x^2$$
- PTS: 2 REF: fall0703ia STA: A.A.12 TOP: Division of Powers
- 4 ANS: 4 PTS: 2 REF: fall0704ia STA: A.A.29
TOP: Set Theory
- 5 ANS: 3 PTS: 2 REF: fall0705ia STA: A.N.1
TOP: Identifying Properties
- 6 ANS: 3 PTS: 2 REF: fall0706ia STA: A.A.19
TOP: Factoring the Difference of Perfect Squares
- 7 ANS: 1
A rooster crows before sunrise, not because of the sun.
- PTS: 2 REF: fall0707ia STA: A.S.14 TOP: Analysis of Data
- 8 ANS: 3
 $5x + 2y = 48$
 $3x + 2y = 32$
 $2x = 16$
 $x = 8$
- PTS: 2 REF: fall0708ia STA: A.A.7 TOP: Writing Linear Systems
- 9 ANS: 2
The median score, 10, is the vertical line in the center of the box.
- PTS: 2 REF: fall0709ia STA: A.S.5 TOP: Box-and-Whisker Plots
- 10 ANS: 3 PTS: 2 REF: fall0710ia STA: A.A.31
TOP: Set Theory
- 11 ANS: 1
 $30^2 + 40^2 = c^2$. 30, 40, 50 is a multiple of 3, 4, 5.
 $2500 = c^2$
 $50 = c$
- PTS: 2 REF: fall0711ia STA: A.A.45 TOP: Pythagorean Theorem

12 ANS: 4

$$V = \pi r^2 h = \pi \cdot 6^2 \cdot 15 \approx 1696.5$$

PTS: 2 REF: fall0712ia STA: A.G.2 TOP: Volume

13 ANS: 1

$$m = \frac{3-0}{0-2} = -\frac{3}{2}. \text{ Using the given y-intercept } (0,3) \text{ to write the equation of the line } y = -\frac{3}{2}x + 3.$$

PTS: 2 REF: fall0713ia STA: A.A.35 TOP: Writing Linear Equations

14 ANS: 2

The two values are shoe size and height.

PTS: 2 REF: fall0714ia STA: A.S.2 TOP: Analysis of Data

15 ANS: 4

PTS: 2 REF: fall0715ia STA: A.A.5

TOP: Modeling Inequalities

16 ANS: 3

$$m = \frac{4-10}{3-(-6)} = -\frac{2}{3}$$

PTS: 2 REF: fall0716ia STA: A.A.33 TOP: Slope

17 ANS: 4

PTS: 2 REF: fall0717ia STA: A.G.4

TOP: Families of Functions

18 ANS: 2

$$\frac{9x^4 - 27x^6}{3x^3} = \frac{9x^4(1 - 3x^2)}{3x^3} = 3x(1 - 3x^2)$$

PTS: 2 REF: fall0718ia STA: A.A.14 TOP: Rational Expressions

19 ANS: 3

$$35000(1 - 0.05)^4 \approx 28507.72$$

PTS: 2 REF: fall0719ia STA: A.A.9 TOP: Exponential Functions

20 ANS: 2

The slope of the inequality is $-\frac{1}{2}$.

PTS: 2 REF: fall0720ia STA: A.G.6 TOP: Linear Inequalities

21 ANS: 1

$$\sin C = \frac{\text{opposite}}{\text{hypotenuse}} = \frac{13}{85}$$

PTS: 2 REF: fall0721ia STA: A.A.42 TOP: Trigonometric Ratios

22 ANS: 4

The transformation is a reflection in the x -axis.

PTS: 2 REF: fall0722ia STA: A.G.5 TOP: Graphing Absolute Value Functions

23 ANS: 1 PTS: 2 REF: fall0723ia STA: A.M.3
TOP: Error

24 ANS: 1
 $-2x + 5 > 17$
 $-2x > 12$
 $x < -6$

PTS: 2 REF: fall0724ia STA: A.A.21 TOP: Interpreting Solutions
25 ANS: 2 PTS: 2 REF: fall0725ia STA: A.N.4
TOP: Operations with Scientific Notation

26 ANS: 4
 $w(w + 5) = 36$
 $w^2 + 5w - 36 = 0$

PTS: 2 REF: fall0726ia STA: A.A.5 TOP: Modeling Equations

27 ANS: 4
$$\frac{(d \times 3) + (2 \times 2d)}{2 \times 3} = \frac{3d + 4d}{6} = \frac{7d}{6}$$

PTS: 2 REF: fall0727ia STA: A.A.17 TOP: Addition and Subtraction of Rationals
28 ANS: 1 PTS: 2 REF: fall0728ia STA: A.A.15
TOP: Undefined Rationals

29 ANS: 4 PTS: 2 REF: fall0729ia STA: A.A.2
TOP: Expressions

30 ANS: 4 PTS: 2 REF: fall0730ia STA: A.G.3
TOP: Defining Functions

31 ANS:
 $30\sqrt{2}. 5\sqrt{72} = 5\sqrt{36}\sqrt{2} = 30\sqrt{2}$

PTS: 2 REF: fall0731ia STA: A.N.2 TOP: Simplifying Radicals
32 ANS:

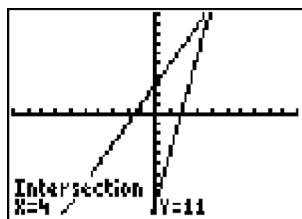

4. $3 + 2g = 5g - 9$
 $12 = 3g$
 $g = 4$

PTS: 2 REF: fall0732ia STA: A.A.22 TOP: Solving Equations

33 ANS:

33.4. Serena needs 24 (9+6+9) feet of fencing to surround the rectangular portion of the garden. The length of the fencing needed for the semicircular portion of the garden is $\frac{1}{2}\pi d = 3\pi \approx 9.4$ feet.

PTS: 2 REF: fall0733ia STA: A.G.1 TOP: Compositions of Polygons and Circles

34 ANS:

50, 1.5, 10. $\frac{\text{distance}}{\text{time}} = \frac{60}{1.2} = 50$. $\frac{\text{distance}}{\text{time}} = \frac{60}{40} = 1.5$. speed \times time = $55 \times 2 = 110$. $120 - 110 = 10$

PTS: 3 REF: fall0734ia STA: A.M.1 TOP: Speed

35 ANS:

7. $15x + 22 \geq 120$
 $x \geq 6.\bar{53}$

PTS: 3 REF: fall0735ia STA: A.A.6 TOP: Modeling Inequalities

36 ANS:

(S,S), (S,K), (**S,D**), (K,S), (K,K), (**K,D**), (**D,S**), (**D,K**), (D,D), $\frac{4}{9}$

PTS: 3 REF: fall0736ia STA: A.S.19 TOP: Sample Space

37 ANS:

225000, 175000, the median better represents the value since it is closer to more values than the mean.

PTS: 4 REF: fall0737ia STA: A.S.4
 TOP: Frequency Histograms, Bar Graphs and Tables

38 ANS:

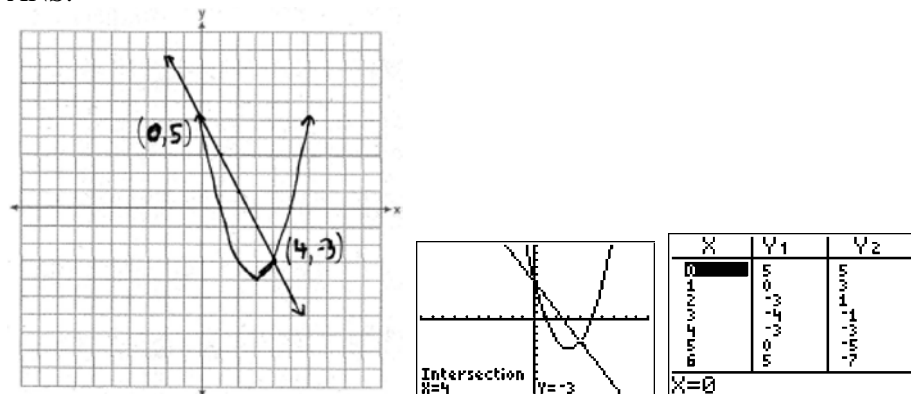

PTS: 4 REF: fall0738ia STA: A.G.9 TOP: Quadratic-Linear Systems

39 ANS:

$$6, -2. \quad \frac{x+1}{x} = \frac{-7}{x-12}$$

$$(x+1)(x-12) = -7x$$

$$x^2 - 11x - 12 = -7x$$

$$x^2 - 4x - 12 = 0$$

$$(x-6)(x+2) = 0$$

$$x = 6 \text{ or } -2$$

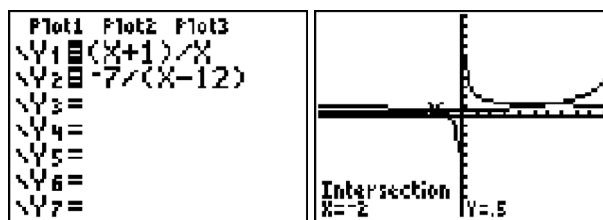

PTS: 4

REF: fall0739ia

STA: A.A.26

TOP: Solving Rationals

0608ia

Answer Section

1 ANS: 1 PTS: 2 REF: 060801ia STA: A.G.4
TOP: Families of Functions

2 ANS: 4

$$P(G \text{ or } W) = \frac{4}{8}, P(G \text{ or } B) = \frac{3}{8}, P(Y \text{ or } B) = \frac{4}{8}, P(Y \text{ or } G) = \frac{5}{8}$$

PTS: 2 REF: 060802ia STA: A.S.22 TOP: Theoretical Probability

3 ANS: 1

To determine student interest, survey the widest range of students.

PTS: 2 REF: 060803ia STA: A.S.3 TOP: Analysis of Data

4 ANS: 1 PTS: 2 REF: 060804ia STA: A.A.19

TOP: Factoring the Difference of Perfect Squares

5 ANS: 4 PTS: 2 REF: 060805ia STA: A.S.12

TOP: Scatter Plots

6 ANS: 2

$$3c + 4m = 12.50$$

$$3c + 2m = 8.50$$

$$2m = 4.00$$

$$m = 2.00$$

PTS: 2 REF: 060806ia STA: A.A.7 TOP: Writing Linear Systems

7 ANS: 1 PTS: 2 REF: 060807ia STA: A.A.13

TOP: Multiplication of Polynomials

8 ANS: 3 PTS: 2 REF: 060808ia STA: A.N.8

TOP: Permutations

9 ANS: 2

$$1.5^3 = 3.375$$

PTS: 2 REF: 060809ia STA: A.G.2 TOP: Volume

10 ANS: 4

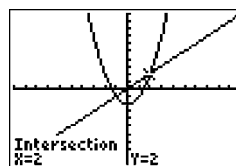

$$x^2 - 2 = x \quad \text{Since } y = x, \text{ the solutions are } (2, 2) \text{ and } (-1, -1).$$

$$x^2 - x - 2 = 0$$

$$(x - 2)(x + 1) = 0$$

$$x = 2 \text{ or } -1$$

PTS: 2 REF: 060810ia STA: A.A.11 TOP: Quadratic-Linear Systems

- 11 ANS: 1 PTS: 2 REF: 060811ia STA: A.G.10
TOP: Identifying the Vertex of a Quadratic Given Graph
- 12 ANS: 3
 $b = 42 - r$ $r = 2b + 3$
 $r = 2b + 3$ $r = 2(42 - r) + 3$
 $r = 84 - 2r + 3$
 $3r = 87$
 $r = 29$
- PTS: 2 REF: 060812ia STA: A.A.7 TOP: Writing Linear Systems
- 13 ANS: 4
 $\frac{2^6}{2^1} = 2^5$
- PTS: 2 REF: 060813ia STA: A.A.12 TOP: Division of Powers
- 14 ANS: 1
The slope of both is -4 .
- PTS: 2 REF: 060814ia STA: A.A.38 TOP: Parallel and Perpendicular Lines
- 15 ANS: 4
 $\frac{x^2 - 1}{x + 1} \cdot \frac{x + 3}{3x - 3} = \frac{(x + 1)(x - 1)}{x + 1} \cdot \frac{x + 3}{3(x - 1)} = \frac{x + 3}{3}$
- PTS: 2 REF: 060815ia STA: A.A.18 TOP: Multiplication and Division of Rationals
- 16 ANS: 2
 $\sin A = \frac{8}{12}$
 $A \approx 42$
- PTS: 2 REF: 060816ia STA: A.A.43 TOP: Using Trigonometry to Find an Angle
- 17 ANS: 3 PTS: 2 REF: 060817ia STA: A.A.15
TOP: Undefined Rationals
- 18 ANS: 2
The set of integers greater than -2 and less than 6 is $\{-1, 0, 1, 2, 3, 4, 5\}$. The subset of this set that is the positive factors of 5 is $\{1, 5\}$. The complement of this subset is $\{-1, 0, 2, 3, 4\}$.
- PTS: 2 REF: 060818ia STA: A.A.30 TOP: Set Theory
- 19 ANS: 3
The other situations are quantitative.
- PTS: 2 REF: 060819ia STA: A.S.1 TOP: Analysis of Data

20 ANS: 3

$$m = \frac{1 - (-4)}{-6 - 4} = -\frac{1}{2}$$

PTS: 2 REF: 060820ia STA: A.A.33 TOP: Slope

21 ANS: 2 PTS: 2 REF: 060821ia STA: A.A.5
TOP: Modeling Inequalities22 ANS: 3
 $25 - 18 = 7$ PTS: 2 REF: 060822ia STA: A.S.9
TOP: Frequency Histograms, Bar Graphs and Tables23 ANS: 4
 $25(x - 3) = 25x - 75$

PTS: 2 REF: 060823ia STA: A.A.1 TOP: Expressions

24 ANS: 2
$$\frac{2x^2 - 12x}{x - 6} = \frac{2x(x - 6)}{x - 6} = 2x$$

PTS: 2 REF: 060824ia STA: A.A.14 TOP: Rational Expressions

25 ANS: 3 PTS: 2 REF: 060825ia STA: A.A.45
TOP: Pythagorean Theorem

26 ANS: 4

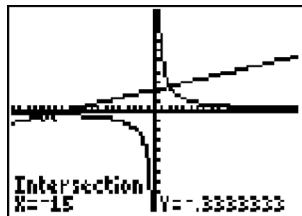

$$\frac{5}{x} = \frac{x + 13}{6}$$

$$x^2 + 13x = 30$$

$$x^2 + 13x - 30 = 0$$

$$(x + 15)(x - 2) = 0$$

$$x = -15 \text{ or } 2$$

PTS: 2 REF: 060826ia STA: A.A.26 TOP: Solving Rationals

27 ANS: 4
 $SA = 2lw + 2hw + 2lh = 2(3)(1.5) + 2(2)(1.5) + 2(3)(2) = 27$

PTS: 2 REF: 060827ia STA: A.G.2 TOP: Surface Area

28 ANS: 1

$$\frac{\sqrt{32}}{4} = \frac{\sqrt{16}\sqrt{2}}{4} = \sqrt{2}$$

PTS: 2 REF: 060828ia STA: A.N.2 TOP: Simplifying Radicals

29 ANS: 4 PTS: 2 REF: 060829ia STA: A.G.5
TOP: Graphing Quadratic Functions30 ANS: 2 PTS: 2 REF: 060830ia STA: A.A.9
TOP: Exponential Functions

31 ANS:

Ann's. $\frac{225}{15} = 15$ mpg is greater than $\frac{290}{23.2} = 12.5$ mpg

PTS: 2 REF: 060831ia STA: A.M.1 TOP: Using Rate

32 ANS:

 $36 - 9\pi$. 15.6. Area of square–area of 4 quarter circles. $(3 + 3)^2 - 3^2\pi = 36 - 9\pi$

PTS: 2 REF: 060832ia STA: A.G.1 TOP: Compositions of Polygons and Circles

33 ANS:
 $0 \leq t \leq 40$

PTS: 2 REF: 060833ia STA: A.A.31 TOP: Set Theory

34 ANS:

 $10 + 2d \geq 75$, 33. $10 + 2d \geq 75$

$$d \geq 32.5$$

PTS: 3 REF: 060834ia STA: A.A.6 TOP: Modeling Inequalities

35 ANS:

 $\frac{1}{6}$, 16.67%, \$13.50. $\frac{18-15}{18} = \frac{1}{6}$. $18 \times 0.75 = 13.5$

PTS: 3 REF: 060835ia STA: A.N.5 TOP: Percents

36 ANS:

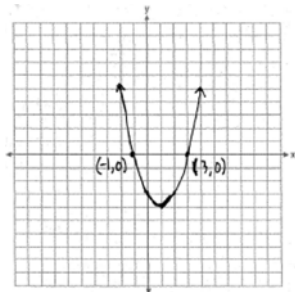

PTS: 3 REF: 060836ia STA: A.G.8 TOP: Solving Quadratics by Graphing

37 ANS:

$$w(w+15) = 54, 3, 18. \quad w(w+15) = 54$$

$$w^2 + 15w - 54 = 0$$

$$(w+18)(w-3) = 0$$

$$w = 3$$

PTS: 4

REF: 060837ia

STA: A.A.8

TOP: Geometric Applications of Quadratics

38 ANS:

618.45, 613.44, 0.008. $21.7 \times 28.5 = 618.45$. $21.6 \times 28.4 = 613.44$. $\left| \frac{618.45 - 613.44}{613.44} \right| \approx 0.008$. An error of less than 1% would seem to be insignificant.

PTS: 4

REF: 060838ia

STA: A.M.3

TOP: Error

39 ANS:

315,000, 180,000, the median better represents value since it is closer to more prices than the mean.

PTS: 4

REF: 060839ia

STA: A.S.4

TOP: Frequency Histograms, Bar Graphs and Tables

0808ia Answer Section

1 ANS: 4

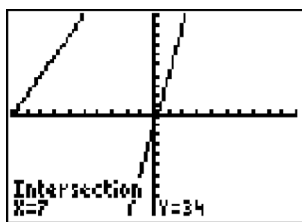

$$5p - 1 = 2p + 20$$

$$3p = 21$$

$$p = 7$$

PTS: 2

REF: 080801ia

STA: A.A.22

TOP: Solving Equations

2 ANS: 2

PTS: 2

REF: 080802ia

STA: A.N.1

TOP: Identifying Properties

3 ANS: 1

PTS: 2

REF: 080803ia

STA: A.A.4

TOP: Modeling Inequalities

4 ANS: 3

mean = 6, median = 6 and mode = 7

PTS: 2

REF: 080804ia

STA: A.S.4

TOP: Central Tendency

5 ANS: 4

$$-4x + 2 > 10$$

$$-4x > 8$$

$$x < -2$$

PTS: 2

REF: 080805ia

STA: A.A.21

TOP: Interpreting Solutions

6 ANS: 2

$$2x^2 + 10x - 12 = 2(x^2 + 5x - 6) = 2(x + 6)(x - 1)$$

PTS: 2

REF: 080806ia

STA: A.A.20

TOP: Factoring Polynomials

7 ANS: 2

If the car can travel 75 miles on 4 gallons, it can travel 300 miles on 16 gallons. $\frac{75}{4} = \frac{x}{16}$.

$$x = 300$$

PTS: 2

REF: 080807ia

STA: A.G.4

TOP: Graphing Linear Functions

8 ANS: 3

$$3ax + b = c$$

$$3ax = c - b$$

$$x = \frac{c - b}{3a}$$

PTS: 2

REF: 080808ia

STA: A.A.23

TOP: Transforming Formulas

9 ANS: 4

$$16^2 + b^2 = 34^2$$

$$b^2 = 900$$

$$b = 30$$

PTS: 2

REF: 080809ia

STA: A.A.45

TOP: Pythagorean Theorem

10 ANS: 2

PTS: 2

REF: 080810ia

STA: A.A.36

TOP: Parallel and Perpendicular Lines

11 ANS: 2

$$s + o = 126, s + 2s = 126$$

$$o = 2s \quad s = 42$$

PTS: 2

REF: 080811ia

STA: A.A.7

TOP: Writing Linear Systems

12 ANS: 2

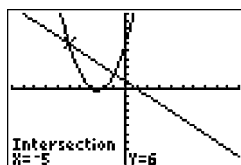

$$x^2 + 5x + 6 = -x + 1, \quad y = -x + 1$$

$$x^2 + 6x + 5 = 0 \quad = -(-5) + 1$$

$$(x + 5)(x + 1) = 0 \quad = 6$$

$$x = -5 \text{ or } -1$$

PTS: 2

REF: 080812ia

STA: A.A.11

TOP: Quadratic-Linear Systems

13 ANS: 1

PTS: 2

REF: 080813ia

STA: A.G.10

TOP: Identifying the Vertex of a Quadratic Given Graph

14 ANS: 3

$$0.75 \text{ hours} = 45 \text{ minutes. } \frac{120}{1} = \frac{x}{45}$$

$$x = 5400$$

PTS: 2

REF: 080814ia

STA: A.M.1

TOP: Using Rate

15 ANS: 2

PTS: 2

REF: 080815ia

STA: A.G.1

TOP: Compositions of Polygons and Circles

16 ANS: 1

$${}_4P_4 = 4 \times 3 \times 2 \times 1 = 24$$

PTS: 2

REF: 080816ia

STA: A.N.8

TOP: Permutations

17 ANS: 2

$$l(l-5) = 24$$

$$l^2 - 5l - 24 = 0$$

$$(l-8)(l+3) = 0$$

$$l = 8$$

PTS: 2

REF: 080817ia

STA: A.A.8

TOP: Geometric Applications of Quadratics

18 ANS: 3

The value of the third quartile is the last vertical line of the box.

PTS: 2

REF: 080818ia

STA: A.S.6

TOP: Box-and-Whisker Plots

19 ANS: 3

PTS: 2

REF: 080819ia

STA: A.A.13

TOP: Addition and Subtraction of Polynomials

KEY: subtraction

20 ANS: 4

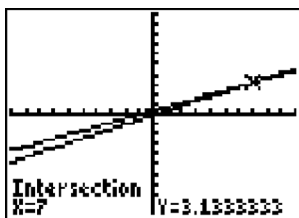

$$\frac{2x}{5} + \frac{1}{3} = \frac{7x-2}{15}$$

$$\frac{(2x \times 3) + (5 \times 1)}{5 \times 3} = \frac{7x-2}{15}$$

$$\frac{6x+5}{15} = \frac{7x-2}{15}$$

$$6x+5 = 7x-2$$

$$x = 7$$

PTS: 2

REF: 080820ia

STA: A.A.25

TOP: Solving Equations with Fractional Expressions

21 ANS: 4

$$\frac{25x-125}{x^2-25} = \frac{25(x-5)}{(x+5)(x-5)} = \frac{25}{x+5}$$

PTS: 2

REF: 080821ia

STA: A.A.16

TOP: Rational Expressions

KEY: $a > 0$

22 ANS: 4



PTS: 2 REF: 080822ia STA: A.S.8 TOP: Scatter Plots

23 ANS: 2 PTS: 2 REF: 080823ia STA: A.A.32

TOP: Slope

24 ANS: 1 PTS: 2 REF: 080824ia STA: A.A.43

TOP: Using Trigonometry to Find an Angle

25 ANS: 4 PTS: 2 REF: 080825ia STA: A.A.40

TOP: Systems of Linear Inequalities

26 ANS: 1

$$\frac{4x}{x-1} \cdot \frac{x^2-1}{3x+3} = \frac{4x}{x-1} \cdot \frac{(x+1)(x-1)}{3(x+1)} = \frac{4x}{3}$$

PTS: 2 REF: 080826ia STA: A.A.18 TOP: Multiplication and Division of Rationals

27 ANS: 4 PTS: 2 REF: 080827ia STA: A.A.12

TOP: Powers of Powers

28 ANS: 1

$$\left| \frac{289-282}{289} \right| \approx 0.024$$

PTS: 2 REF: 080828ia STA: A.M.3 TOP: Error

29 ANS: 3

$$\sin A = \frac{10}{16} \quad B = 180 - (90 + 38.7) = 51.3. \quad \text{A } 90^\circ \text{ angle is not acute.}$$

$$A \approx 38.7$$

PTS: 2 REF: 080829ia STA: A.A.43 TOP: Using Trigonometry to Find an Angle

30 ANS: 2

The events are not mutually exclusive: $P(\text{prime}) = \frac{3}{6}$, $P(\text{even}) = \frac{3}{6}$, $P(\text{prime AND even}) = \frac{1}{6}$

$$P(\text{prime OR even}) = \frac{3}{6} + \frac{3}{6} - \frac{1}{6} = \frac{5}{6}$$

PTS: 2 REF: 080830ia STA: A.S.23 TOP: Theoretical Probability

KEY: not mutually exclusive events

31 ANS:

$$111.25 \cdot \frac{\text{distance}}{\text{time}} = \frac{89}{0.8} = 111.25$$

PTS: 2 REF: 080831ia STA: A.M.1 TOP: Speed

32 ANS:

$$\frac{3}{8} \cdot P(s_1 < 4) \times P(s_2 = \text{back}) = \frac{3}{4} \times \frac{1}{2} = \frac{3}{8}$$

PTS: 2 REF: 080832ia STA: A.S.23 TOP: Theoretical Probability
KEY: independent events

33 ANS:

{1,2,4,5,9,10,12}

PTS: 2 REF: 080833ia STA: A.A.30 TOP: Set Theory

34 ANS:

$$60 - 42\sqrt{5} \cdot 3\sqrt{20}(2\sqrt{5} - 7) = 6\sqrt{100} - 21\sqrt{20} = 60 - 21\sqrt{4}\sqrt{5} = 60 - 42\sqrt{5}$$

PTS: 3 REF: 080834ia STA: A.N.3 TOP: Operations with Radicals
KEY: multiplication

35 ANS:

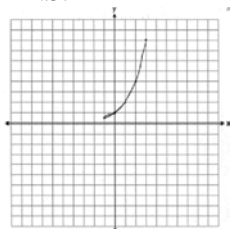
. The graph will never intersect the x -axis as $2^x > 0$ for all values of x .

PTS: 3 REF: 080835ia STA: A.G.4 TOP: Graphing Exponential Functions

36 ANS:

$$y = \frac{2}{5}x + 2. \quad m = \frac{4-0}{5-(-5)} = \frac{2}{5}. \quad y = mx + b$$

$$4 = \frac{2}{5}(5) + b$$

$$b = 2$$

PTS: 3 REF: 080836ia STA: A.A.35 TOP: Writing Linear Equations

37 ANS:

$$m = 50¢, p = 15¢. \quad 3m + 2p = 1.80. \quad 9m + 6p = 5.40 \quad . \quad 4(.50) + 6p = 2.90$$

$$4m + 6p = 2.90 \quad 4m + 6p = 2.90 \quad 6p = .90$$

$$5m = 2.50 \quad p = \$0.15$$

$$m = \$0.50$$

PTS: 4 REF: 080837ia STA: A.A.7 TOP: Writing Linear Systems

38 ANS:

Number of Days Outside			Number of Days Outside	
Interval	Tally	Frequency	Interval	Cumulative Frequency
0-1		3	0-1	3
2-3		7	0-3	10
4-5		7	0-5	17
6-7		3	0-7	20

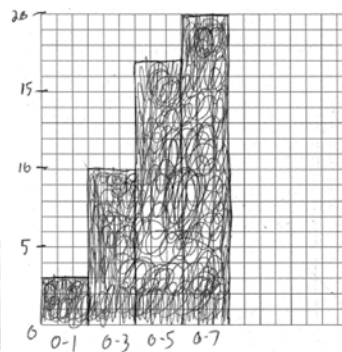

PTS: 4 REF: 080838ia STA: A.S.5
 TOP: Frequency Histograms, Bar Graphs and Tables

39 ANS:

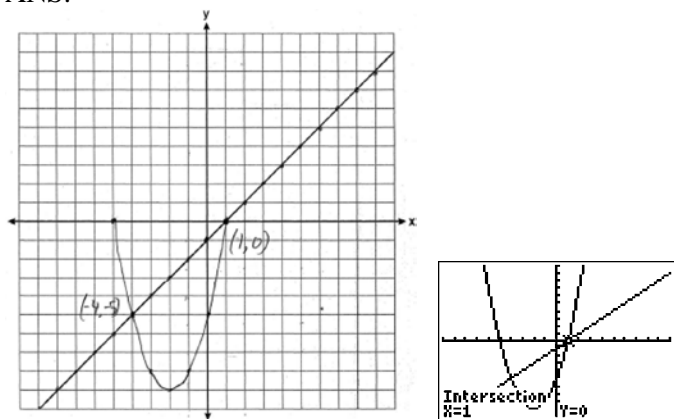

PTS: 4 REF: 080839ia STA: A.G.9 TOP: Quadratic-Linear Systems

0109ia

Answer Section

1 ANS: 3

$$F = \frac{9}{5}C + 32 = \frac{9}{5}(15) + 32 = 59$$

PTS: 2 REF: 010901ia STA: A.M.2 TOP: Conversions

2 ANS: 4

$$\frac{\text{distance}}{\text{time}} = \frac{24}{6} = 4$$

PTS: 2 REF: 010902ia STA: A.M.1 TOP: Speed

3 ANS: 4

$$P(O) = \frac{3}{6}, P(E) = \frac{3}{6}, P(< 6) = \frac{5}{6}, P(> 4) = \frac{2}{6}$$

PTS: 2 REF: 010903ia STA: A.S.22 TOP: Theoretical Probability

4 ANS: 1

$$0.07m + 19 \leq 29.50$$

$$0.07m \leq 10.50$$

$$m \leq 150$$

PTS: 2 REF: 010904ia STA: A.A.6 TOP: Modeling Inequalities

5 ANS: 1

PTS: 2

REF: 010905ia

STA: A.G.4

TOP: Families of Functions

6 ANS: 3

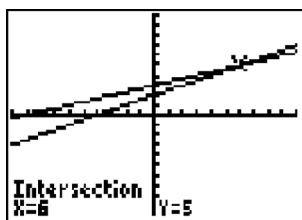

$$\frac{k+4}{2} = \frac{k+9}{3}$$

$$3(k+4) = 2(k+9)$$

$$3k + 12 = 2k + 18$$

$$k = 6$$

PTS: 2 REF: 010906ia STA: A.A.26 TOP: Solving Rationals

7 ANS: 4

The mean is $80.\bar{6}$, the median is 84.5 and the mode is 87.

PTS: 2 REF: 010907ia STA: A.S.4 TOP: Central Tendency

8 ANS: 4

PTS: 2

REF: 010908ia

STA: A.A.9

TOP: Exponential Functions

- 9 ANS: 2 PTS: 2 REF: 010909ia STA: A.A.19
TOP: Factoring the Difference of Perfect Squares
- 10 ANS: 3 PTS: 2 REF: 010910ia STA: A.A.35
TOP: Writing Linear Equations
- 11 ANS: 2
 $P = 2l + 2w$
 $P - 2l = 2w$
 $\frac{P - 2l}{2} = w$
- PTS: 2 REF: 010911ia STA: A.A.23 TOP: Transforming Formulas
- 12 ANS: 3
 $\cos 30 = \frac{x}{24}$
 $x \approx 21$
- PTS: 2 REF: 010912ia STA: A.A.44 TOP: Using Trigonometry to Find a Side
- 13 ANS: 2
 $m = \frac{5-3}{2-7} = -\frac{2}{5}$
- PTS: 2 REF: 010913ia STA: A.A.33 TOP: Slope
- 14 ANS: 3
 $x^2 - 10x + 21 = 0$
 $(x-7)(x-3) = 0$
 $x = 7 \quad x = 3$
- PTS: 2 REF: 010914ia STA: A.A.28 TOP: Roots of Quadratics
- 15 ANS: 2 PTS: 2 REF: 010915ia STA: A.A.5
TOP: Modeling Equations
- 16 ANS: 2 PTS: 2 REF: 010916ia STA: A.G.10
TOP: Identifying the Vertex of a Quadratic Given Graph
- 17 ANS: 3 PTS: 2 REF: 010917ia STA: A.A.29
TOP: Set Theory
- 18 ANS: 1
 $\frac{2}{x} - 3 = \frac{26}{x}$
 $-3 = \frac{24}{x}$
 $x = -8$
- PTS: 2 REF: 010918ia STA: A.A.25 TOP: Solving Rationals

19 ANS: 2

$$\sin U = \frac{\text{opposite}}{\text{hypotenuse}} = \frac{15}{17}$$

PTS: 2

REF: 010919ia

STA: A.A.42

TOP: Trigonometric Ratios

20 ANS: 3

$$\sqrt{72} = \sqrt{36}\sqrt{2} = 6\sqrt{2}$$

PTS: 2

REF: 010920ia

STA: A.N.2

TOP: Simplifying Radicals

21 ANS: 2

$$\frac{6}{5x} - \frac{2}{3x} = \frac{18x - 10x}{15x^2} = \frac{8x}{15x^2} = \frac{8}{15x}$$

PTS: 2

REF: 010921ia

STA: A.A.17

TOP: Addition and Subtraction of Rationals

22 ANS: 2

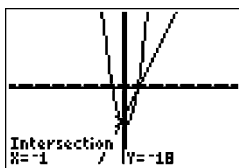

$$x^2 - x - 20 = 3x - 15 \quad y = 3x - 15$$

$$x^2 - 4x - 6 = 0 \quad = 3(-1) - 15$$

$$(x = 5)(x + 1) = 0 \quad = -18$$

$$x = 5 \text{ or } -1$$

PTS: 2

REF: 010922ia

STA: A.A.11

TOP: Quadratic-Linear Systems

23 ANS: 1

Everyone eats, can shop in malls and wear clothes. People who work in a sporting goods store probably watch more sports television than most.

PTS: 2

REF: 010923ia

STA: A.S.3

TOP: Analysis of Data

24 ANS: 4

$$A = lw = (3w - 7)(w) = 3w^2 - 7w$$

PTS: 2

REF: 010924ia

STA: A.A.1

TOP: Expressions

25 ANS: 2

PTS: 2

REF: 010925ia

STA: A.A.15

TOP: Undefined Rationals

26 ANS: 1

The slope of $y = 3 - 2x$ is -2 . Using $m = -\frac{A}{B}$, the slope of $4x + 2y = 5$ is $-\frac{4}{2} = -2$.

PTS: 2

REF: 010926ia

STA: A.A.38

TOP: Parallel and Perpendicular Lines

27 ANS: 4

PTS: 2

REF: 010927ia

STA: A.N.4

TOP: Operations with Scientific Notation

28 ANS: 1

$$\frac{1}{8} \times \frac{1}{8} = \frac{1}{64}$$

PTS: 2 REF: 010928ia STA: A.S.23 TOP: Theoretical Probability

KEY: independent events

29 ANS: 4 PTS: 2 REF: 010929ia STA: A.S.6

TOP: Box-and-Whisker Plots

30 ANS: 4 PTS: 2 REF: 010930ia STA: A.G.3

TOP: Defining Functions

31 ANS:

$$50. 12 + 10 + 12 + \frac{1}{2}(10\pi) \approx 50$$

PTS: 2 REF: 010931ia STA: A.G.1 TOP: Compositions of Polygons and Circles

32 ANS:

$$\frac{3k^2m^6}{4}$$

PTS: 2 REF: 010932ia STA: A.A.12 TOP: Division of Powers

33 ANS:

$$d = 6.25h, 250. d = 6.25(40) = 250$$

PTS: 2 REF: 010933ia STA: A.N.5 TOP: Direct Variation

34 ANS:

$$1,512, 1,551.25, 0.025. 36 \times 42 = 1512. 36.5 \times 42.5 = 1551.25. RE = \left| \frac{1512 - 1551.25}{1551.25} \right| \approx 0.025.$$

PTS: 3 REF: 010934ia STA: A.M.3 TOP: Error

35 ANS:

$$\frac{3}{4x-8} \cdot \frac{3x+6}{4x+12} \div \frac{x^2-4}{x+3} = \frac{3(x+2)}{4(x+3)} \cdot \frac{x+3}{(x+2)(x-2)} = \frac{3}{4(x-2)}$$

PTS: 3 REF: 010935ia STA: A.A.18 TOP: Multiplication and Division of Rationals

36 ANS:

$$\frac{38}{\pi}, 2. V = \pi r^2 h \quad \cdot \frac{36}{\left(\frac{38}{\pi}\right)} \approx 2.97. \text{ Three cans will not fit. The maximum number is 2.}$$

$$342 = \pi \left(\frac{6}{2}\right)^2 h$$

$$\frac{342}{9\pi} = h$$

$$\frac{38}{\pi} = h$$

PTS: 3 REF: 010936ia STA: A.G.2 TOP: Volume

37 ANS:

$$(-2,5). \quad 3x + 2y = 4 \quad 12x + 8y = 16. \quad 3x + 2y = 4$$

$$4x + 3y = 7 \quad 12x + 9y = 21 \quad 3x + 2(5) = 4$$

$$y = 5 \quad 3x = -6$$

$$x = -2$$

PTS: 4

REF: 010937ia

STA: A.A.10

TOP: Solving Linear Systems

38 ANS:

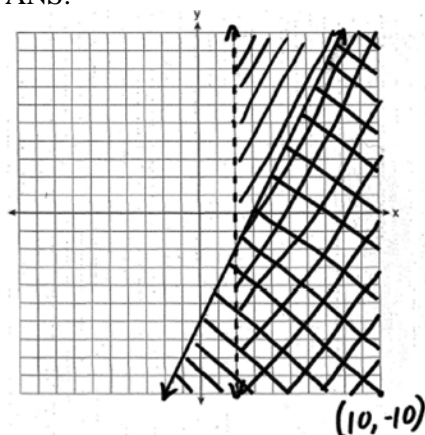

PTS: 4

REF: 010938ia

STA: A.G.7

TOP: Systems of Linear Inequalities

39 ANS:

(H,F,M), (H,F,J), (H,F,S), (H,A,M), (H,A,J), (H,A,S), (C,F,M), (C,F,J), (C,F,S), (C,A,M), (C,A,J), (C,A,S), (T,F,M), (T,F,J), (T,F,S), (T,A,M), (T,A,J), (T,A,S). There are 18 different kids' meals, 12 do not include juice and 6 include chicken nuggets.

PTS: 4

REF: 010939ia

STA: A.S.19

TOP: Sample Space

0609ia Answer Section

1 ANS: 4

$$\frac{5}{45} = \frac{8}{x}$$

$$5x = 360$$

$$x = 72$$

PTS: 2

REF: 060901ia

STA: A.M.1

TOP: Speed

2 ANS: 4

$$x^2 - 7x + 6 = 0$$

$$(x - 6)(x - 1) = 0$$

$$x = 6 \quad x = 1$$

PTS: 2

REF: 060902ia

STA: A.A.28

TOP: Roots of Quadratics

3 ANS: 1

PTS: 2

REF: 060903ia

STA: A.A.12

TOP: Division of Powers

4 ANS: 2

PTS: 2

REF: 060904ia

STA: A.A.1

TOP: Expressions

5 ANS: 3

The other situations are quantitative.

PTS: 2

REF: 060905ia

STA: A.S.1

TOP: Analysis of Data

6 ANS: 4

PTS: 2

REF: 060906ia

STA: A.A.4

TOP: Modeling Inequalities

7 ANS: 1

$$\frac{(2x \times 6) + (3 \times x)}{3 \times 6} = 5$$

$$\frac{12x + 3x}{18} = 5$$

$$15x = 90$$

$$x = 6$$

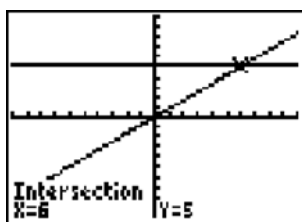

PTS: 2

REF: 060907ia

STA: A.A.25

TOP: Solving Equations with Fractional Expressions

8 ANS: 2

PTS: 2

REF: 060908ia

STA: A.S.21

TOP: Empirical Probability

- 9 ANS: 3
 $3^2 + 5^2 = x^2$
 $34 = x^2$
 $\sqrt{34} = x$
- PTS: 2 REF: 060909ia STA: A.A.45 TOP: Pythagorean Theorem
- 10 ANS: 2
 $\sqrt{32} = \sqrt{16} \sqrt{2} = 4\sqrt{2}$
- PTS: 2 REF: 060910ia STA: A.N.2 TOP: Simplifying Radicals
- 11 ANS: 4
 $\frac{344 \text{ m}}{\text{sec}} \times \frac{60 \text{ sec}}{1 \text{ min}} \times \frac{60 \text{ min}}{1 \text{ hr}} = 1,238,400 \frac{\text{m}}{\text{hr}}$
- PTS: 2 REF: 060911ia STA: A.M.2 TOP: Conversions
- 12 ANS: 2
 $L + S = 47$
 $L - S = 15$
 $2L = 62$
 $L = 31$
- PTS: 2 REF: 060912ia STA: A.A.7 TOP: Writing Linear Systems
- 13 ANS: 3
 $a + ar = b + r$
 $a(1 + r) = b + r$
 $a = \frac{b + r}{1 + r}$
- PTS: 2 REF: 060913ia STA: A.A.23 TOP: Transforming Formulas
- 14 ANS: 1
 $\frac{4}{3}x + 5 < 17$
 $\frac{4}{3}x < 12$
 $4x < 36$
 $x < 9$
- PTS: 2 REF: 060914ia STA: A.A.21 TOP: Interpreting Solutions
- 15 ANS: 3
The value of the upper quartile is the last vertical line of the box.
- PTS: 2 REF: 060915ia STA: A.S.6 TOP: Box-and-Whisker Plots
- 16 ANS: 4 PTS: 2 REF: 060916ia STA: A.A.15
TOP: Undefined Rationals

17 ANS: 1

$$so = f + 60 \quad j = 2f - 50 \quad se = 3f. \quad f + (f + 60) + (2f - 50) + 3f = 1424$$

$$7f + 10 = 1424$$

$$f = 202$$

PTS: 2

REF: 060917ia

STA: A.A.7

TOP: Writing Linear Systems

18 ANS: 1

$$x = \frac{-b}{2a} = \frac{-(-16)}{2(1)} = 8. \quad y = (8)^2 - 16(8) + 63 = -1$$

PTS: 2

REF: 060918ia

STA: A.A.41

TOP: Identifying the Vertex of a Quadratic Given Equation

19 ANS: 3

PTS: 2

REF: 060919ia

STA: A.G.3

TOP: Defining Functions

20 ANS: 1

PTS: 2

REF: 060920ia

STA: A.G.6

TOP: Linear Inequalities

21 ANS: 2

$$\frac{x^2 - 2x - 15}{x^2 + 3x} = \frac{(x - 5)(x + 3)}{x(x + 3)} = \frac{x - 5}{x}$$

PTS: 2

REF: 060921ia

STA: A.A.16

TOP: Rational Expressions

KEY: $a > 0$

22 ANS: 1

$$y = mx + b$$

$$-6 = (-3)(4) + b$$

$$b = 6$$

PTS: 2

REF: 060922ia

STA: A.A.34

TOP: Writing Linear Equations

23 ANS: 2

PTS: 2

REF: 060923ia

STA: A.A.13

TOP: Addition and Subtraction of Polynomials

KEY: subtraction

24 ANS: 3

PTS: 2

REF: 060924ia

STA: A.G.8

TOP: Solving Quadratics by Graphing

25 ANS: 2

$$x + 2y = 9$$

$$x - y = 3$$

$$3y = 6$$

$$y = 2$$

PTS: 2

REF: 060925ia

STA: A.A.10

TOP: Solving Linear Systems

26 ANS: 3

PTS: 2

REF: 060926ia

STA: A.N.1

TOP: Properties of Reals

27 ANS: 4

PTS: 2

REF: 060927ia

STA: A.N.4

TOP: Operations with Scientific Notation

28 ANS: 2

The volume of the cube using Ezra's measurements is $8 (2^3)$. The actual volume is $9.261 (2.1^3)$. The relative error

$$\text{is } \left| \frac{9.261 - 8}{9.261} \right| \approx 0.14.$$

PTS: 2 REF: 060928ia STA: A.M.3 TOP: Error

29 ANS: 2

$$\frac{6}{4a} - \frac{2}{3a} = \frac{18a - 8a}{12a^2} = \frac{10a}{12a^2} = \frac{5}{6a}$$

PTS: 2 REF: 060929ia STA: A.A.17 TOP: Addition and Subtraction of Rationals

30 ANS: 4

PTS: 2 REF: 060930ia STA: A.A.29

TOP: Set Theory

31 ANS:

$$60. {}_5P_3 = 60$$

PTS: 2 REF: 060931ia STA: A.N.8 TOP: Permutations

32 ANS:

$$4x(x+3)(x-3). \quad 4x^3 - 36x = 4x(x^2 - 9) = 4x(x+3)(x-3)$$

PTS: 2 REF: 060932ia STA: A.A.19

TOP: Factoring the Difference of Perfect Squares

33 ANS:

$\frac{1}{8}$. After the English and social studies books are taken, 8 books are left and 1 is an English book.

PTS: 2 REF: 060933ia STA: A.S.18 TOP: Conditional Probability

34 ANS:

56. If the circumference of circle O is 16π inches, the diameter, \overline{AD} , is 16 inches and the length of \overline{BC} is 12 inches $\frac{3}{4} \times 16$. The area of trapezoid $ABCD$ is $\frac{1}{2} \times 4(12 + 16) = 56$.

PTS: 3 REF: 060934ia STA: A.G.1 TOP: Compositions of Polygons and Circles

35 ANS:

$$5,583.86. \quad A = P(1 + R)^t = 5000(1 + 0.0375)^3 \approx 5583.86$$

PTS: 3 REF: 060935ia STA: A.A.9 TOP: Exponential Functions

36 ANS:

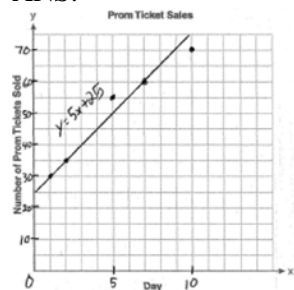

PTS: 3 REF: 060936ia STA: A.S.8 TOP: Scatter Plots

37 ANS:

39, 63. $\tan 52 = \frac{50}{x}$. $\sin 52 = \frac{50}{x}$
 $x \approx 39$ $x \approx 63$

PTS: 4 REF: 060937ia STA: A.A.44 TOP: Using Trigonometry to Find a Side

38 ANS:

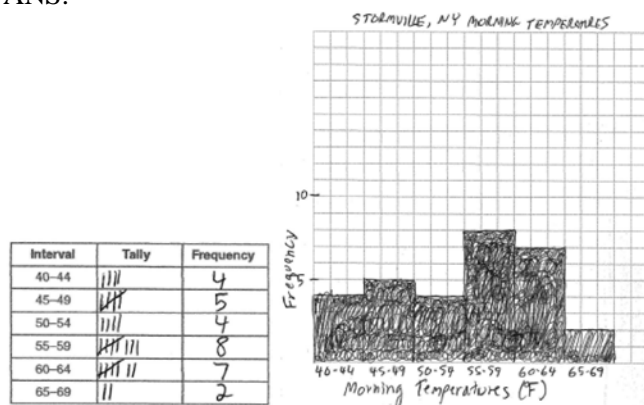

PTS: 4 REF: 060938ia STA: A.S.5
 TOP: Frequency Histograms, Bar Graphs and Tables

39 ANS:

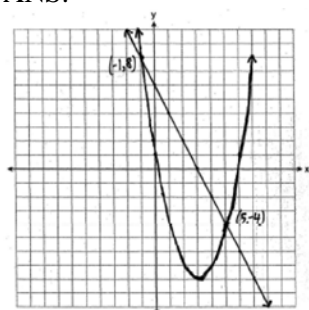

PTS: 4 REF: 060939ia STA: A.G.9 TOP: Quadratic-Linear Systems

0809ia
Answer Section

- 1 ANS: 2 PTS: 2 REF: 080901ia STA: A.A.4
TOP: Modeling Equations
- 2 ANS: 1 PTS: 2 REF: 080902ia STA: A.A.19
TOP: Factoring the Difference of Perfect Squares
- 3 ANS: 4 PTS: 2 REF: 080903ia STA: A.A.12
TOP: Multiplication of Powers
- 4 ANS: 1
 $13.95 + 0.49s \leq 50.00$
 $0.49s \leq 36.05$
 $s \leq 73.57$
- PTS: 2 REF: 080904ia STA: A.A.6 TOP: Modeling Inequalities
- 5 ANS: 3
 $(3-1) \times 2 \times 3 = 12$
- PTS: 2 REF: 080905ia STA: A.N.7 TOP: Conditional Probability
- 6 ANS: 1
 $8^2 + 15^2 = c^2$
 $c^2 = 289$
 $c = 17$
- PTS: 2 REF: 080906ia STA: A.A.45 TOP: Pythagorean Theorem
- 7 ANS: 3 PTS: 2 REF: 080907ia STA: A.S.20
TOP: Theoretical Probability
- 8 ANS: 3
The number of correct answers on a test causes the test score.
- PTS: 2 REF: 080908ia STA: A.S.13 TOP: Analysis of Data
- 9 ANS: 2
 $\frac{3}{5}(x+2) = x-4$
 $3(x+2) = 5(x-4)$
 $3x+6 = 5x-20$
 $26 = 2x$
 $x = 13$
- PTS: 2 REF: 080909ia STA: A.A.25
TOP: Solving Equations with Fractional Expressions

- 10 ANS: 4
Surveying persons leaving a football game about a sports budget contains the most bias.
- PTS: 2 REF: 080910ia STA: A.S.3 TOP: Analysis of Data
- 11 ANS: 1 PTS: 2 REF: 080911ia STA: A.A.36
TOP: Parallel and Perpendicular Lines
- 12 ANS: 4
 $A = \{2, 4, 6, 8, 10, 12, 14, 16, 18, 20\}$
- PTS: 2 REF: 080912ia STA: A.A.30 TOP: Set Theory
- 13 ANS: 4
 $-2(x - 5) < 4$
 $-2x + 10 < 4$
 $-2x < -6$
 $x > 3$
- PTS: 2 REF: 080913ia STA: A.A.21 TOP: Interpreting Solutions
- 14 ANS: 2
 $\tan 32 = \frac{x}{25}$
 $x \approx 15.6$
- PTS: 2 REF: 080914ia STA: A.A.44 TOP: Using Trigonometry to Find a Side
- 15 ANS: 1
 $m = \frac{4 - (-4)}{-5 - 15} = -\frac{2}{5}$
- PTS: 2 REF: 080915ia STA: A.A.33 TOP: Slope
- 16 ANS: 2 PTS: 2 REF: 080916ia STA: A.G.8
TOP: Solving Quadratics by Graphing
- 17 ANS: 2
 $\frac{2}{3x} + \frac{4}{3x} = \frac{9x + 8x}{6x^2} = \frac{17x}{6x^2} = \frac{17}{6x}$
- PTS: 2 REF: 080917ia STA: A.A.17 TOP: Addition and Subtraction of Rationals
- 18 ANS: 1
 $x^2 + 7x + 10 = 0$
 $(x + 5)(x + 2) = 0$
 $x = -5$ or -2
- PTS: 2 REF: 080918ia STA: A.A.15 TOP: Undefined Rationals

19 ANS: 3

An element of the domain, 1, is paired with two different elements of the range, 3 and 7.

PTS: 2 REF: 080919ia STA: A.G.3 TOP: Defining Functions

20 ANS: 1

$$x - 2y = 1$$

$$x + 4y = 7$$

$$-6y = -6$$

$$y = 1$$

PTS: 2 REF: 080920ia STA: A.A.10 TOP: Solving Linear Systems

21 ANS: 3

$$x^2 - 6x = 0$$

$$x(x - 6) = 0$$

$$x = 0 \quad x = 6$$

PTS: 2 REF: 080921ia STA: A.A.27 TOP: Solving Quadratics by Factoring

22 ANS: 2

$$5\sqrt{20} = 5\sqrt{4}\sqrt{5} = 10\sqrt{5}$$

PTS: 2 REF: 080922ia STA: A.N.2 TOP: Simplifying Radicals

23 ANS: 3

$$|-5(5) + 12| = |-13| = 13$$

PTS: 2 REF: 080923ia STA: A.N.6 TOP: Evaluating Expressions

24 ANS: 1

PTS: 2

REF: 080924ia

STA: A.G.1

TOP: Compositions of Polygons and Circles

25 ANS: 3

PTS: 2

REF: 080925ia

STA: A.G.4

TOP: Identifying the Equation of a Graph

26 ANS: 2

$$\left| \frac{149.6 - 174.2}{149.6} \right| \approx 0.1644$$

PTS: 2 REF: 080926ia STA: A.M.3 TOP: Error

27 ANS: 4

$$y = mx + b$$

$$-1 = (2)(3) + b$$

$$b = -7$$

PTS: 2 REF: 080927ia STA: A.A.34 TOP: Writing Linear Equations

28 ANS: 4

Let x = youngest brother and $x + 4$ = oldest brother. $3x - (x + 4) = 48$.

$$2x - 4 = 48$$

$$x = 26$$

PTS: 2 REF: 080928ia STA: A.A.6 TOP: Modeling Equations

29 ANS: 3

$$500(1 + 0.06)^3 \approx 596$$

PTS: 2 REF: 080929ia STA: A.A.9 TOP: Exponential Functions

30 ANS: 2 PTS: 2 REF: 080930ia STA: A.S.17

TOP: Scatter Plots

31 ANS:

Not all of the homework problems are equations. The first problem is an expression.

PTS: 2 REF: 080931ia STA: A.A.3 TOP: Expressions

32 ANS:

$$5,112. (12 \times 30 \times 16) - (6 \times 12 \times 9) = 5112$$

PTS: 2 REF: 080932ia STA: A.G.2 TOP: Volume

33 ANS:

$$\frac{3}{8}. (H,H,H), (H,H,T), (H,T,H), (H,T,T), (T,H,H), (T,H,T), (T,T,H), (T,T,T)$$

PTS: 2 REF: 080933ia STA: A.S.19 TOP: Sample Space

34 ANS:

$$(-2, 11). \quad x = \frac{-b}{2a} = \frac{-(-8)}{2(-2)} = -2$$

$$y = -2(-2)^2 - 8(-2) + 3 = 11$$

PTS: 3 REF: 080934ia STA: A.A.41

TOP: Identifying the Vertex of a Quadratic Given Equation

35 ANS:

$$30.4\%; \text{ no, } 23.3\%. \quad \frac{7.50 - 5.75}{5.75} = 30.4\%. \quad \frac{7.50 - 5.75}{7.50} = 23.3\%$$

PTS: 3 REF: 080935ia STA: A.N.5 TOP: Percents

36 ANS:

$$\text{Greg's rate of 5.5 is faster than Dave's rate of 5.3. } \frac{\text{distance}}{\text{time}} = \frac{11}{2} = 5.5. \quad \frac{16}{3} = 5.\bar{3}$$

PTS: 3 REF: 080936ia STA: A.M.1 TOP: Speed

37 ANS:

$$\frac{x-7}{3x} \cdot \frac{2x^2-8x-42}{6x^2} \div \frac{x^2-9}{x^2-3x} = \frac{2(x^2-4x-21)}{6x^2} \cdot \frac{x(x-3)}{(x+3)(x-3)} = \frac{(x-7)(x+3)}{3x} \cdot \frac{1}{x+3} = \frac{x-7}{3x}$$

PTS: 4

REF: 080937ia

STA: A.A.18

TOP: Multiplication and Division of Rationals

38 ANS:

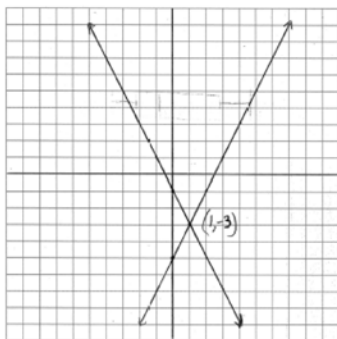

PTS: 4

REF: 080938ia

STA: A.G.7

TOP: Solving Linear Systems

39 ANS:

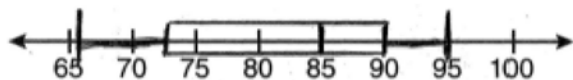

PTS: 4

REF: 080939ia

STA: A.S.5

TOP: Box-and-Whisker Plots

0110ia

Answer Section

- 1 ANS: 1 PTS: 2 REF: 011001ia STA: A.S.6
TOP: Box-and-Whisker Plots
- 2 ANS: 2 PTS: 2 REF: 011002ia STA: A.S.20
TOP: Theoretical Probability
- 3 ANS: 1
 $1P + 2C = 5$
 $1P + 4C = 6$
 $2C = 1$
 $C = 0.5$
- PTS: 2 REF: 011003ia STA: A.A.7 TOP: Writing Linear Systems
- 4 ANS: 1 PTS: 2 REF: 011004ia STA: A.A.31
TOP: Set Theory
- 5 ANS: 2 PTS: 2 REF: 011005ia STA: A.A.5
TOP: Modeling Inequalities
- 6 ANS: 2
 $R = 0.5^{d-1}$
- PTS: 2 REF: 011006ia STA: A.A.9 TOP: Exponential Functions
- 7 ANS: 4
 $A(-3,4)$ and $B(5,8)$. $m = \frac{4-8}{-3-5} = \frac{-4}{-8} = \frac{1}{2}$
- PTS: 2 REF: 011007ia STA: A.A.33 TOP: Slope
- 8 ANS: 3
 $\cos A = \frac{\text{adjacent}}{\text{hypotenuse}} = \frac{15}{17}$
- PTS: 2 REF: 011008ia STA: A.A.42 TOP: Trigonometric Ratios
- 9 ANS: 2
Debbie failed to distribute the 3 properly.
- PTS: 2 REF: 011009ia STA: A.A.22 TOP: Solving Equations
- 10 ANS: 1
 $-|a-b| = -|7-(-3)| = -|-10| = -10$
- PTS: 2 REF: 011010ia STA: A.N.6 TOP: Evaluating Expressions
- 11 ANS: 3
 $\frac{12x^3 - 6x^2 + 2x}{2x} = \frac{2x(6x^2 - 3x + 1)}{2x} = 6x^2 - 3x + 1$
- PTS: 2 REF: 011011ia STA: A.A.14 TOP: Rational Expressions

12 ANS: 2 PTS: 2 REF: 011012ia STA: A.G.9
TOP: Quadratic-Linear Systems

13 ANS: 3

$$m = \frac{7-3}{-3-3} = \frac{4}{-6} = -\frac{2}{3} \quad y = mx + b$$

$$3 = -\frac{2}{3}(3) + b$$

$$3 = -2 + b$$

$$5 = b$$

PTS: 2 REF: 011013ia STA: A.A.35 TOP: Writing Linear Equations

14 ANS: 3

Frequency is not a variable.

PTS: 2 REF: 011014ia STA: A.S.2 TOP: Analysis of Data

15 ANS: 2 PTS: 2 REF: 011015ia STA: A.G.10

TOP: Identifying the Vertex of a Quadratic Given Graph

16 ANS: 4 PTS: 2 REF: 011016ia STA: A.A.23

TOP: Transforming Formulas

17 ANS: 3 PTS: 2 REF: 011017ia STA: A.G.5

TOP: Graphing Absolute Value Functions

18 ANS: 4

In (4), each element in the domain corresponds to a unique element in the range.

PTS: 2 REF: 011018ia STA: A.G.3 TOP: Defining Functions

19 ANS: 2 PTS: 2 REF: 011019ia STA: A.S.12

TOP: Scatter Plots

20 ANS: 4 PTS: 2 REF: 011020ia STA: A.A.12

TOP: Multiplication of Powers

21 ANS: 1

$$4y - 2x = 0$$

$$4(-1) - 2(-2) = 0$$

$$-4 + 4 = 0$$

PTS: 2 REF: 011021ia STA: A.A.39 TOP: Identifying Points on a Line

22 ANS: 2 PTS: 2 REF: 011022ia STA: A.A.19

TOP: Factoring the Difference of Perfect Squares

23 ANS: 2 PTS: 2 REF: 011023ia STA: A.A.40

TOP: Systems of Linear Inequalities

24 ANS: 4

$$6\sqrt{50} + 6\sqrt{2} = 6\sqrt{25} \sqrt{2} + 6\sqrt{2} = 30\sqrt{2} + 6\sqrt{2} = 36\sqrt{2}$$

PTS: 2 REF: 011024ia STA: A.N.3 TOP: Operations with Radicals

KEY: addition

25 ANS: 4 PTS: 2 REF: 011025ia STA: A.A.17
TOP: Addition and Subtraction of Rationals

26 ANS: 1

The slope of $2x - 4y = 16$ is $\frac{-A}{B} = \frac{-2}{-4} = \frac{1}{2}$

PTS: 2 REF: 011026ia STA: A.A.38 TOP: Parallel and Perpendicular Lines

27 ANS: 2 PTS: 2 REF: 011027ia STA: A.A.3

TOP: Expressions

28 ANS: 4

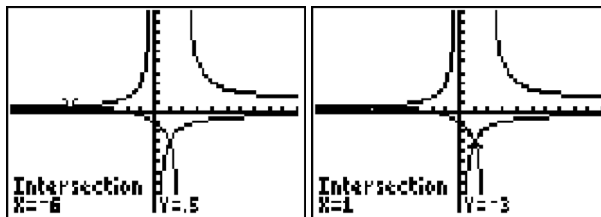

$$\frac{x+2}{x-2} = \frac{-3}{x}$$

$$x(x+2) = -3(x-2)$$

$$x^2 + 2x = -3x + 6$$

$$x^2 + 5x - 6 = 0$$

$$(x+6)(x-1) = 0$$

$$x = -6 \text{ or } 1$$

PTS: 2 REF: 011028ia STA: A.A.26 TOP: Solving Rationals

29 ANS: 4

$$SA = 2lw + 2hw + 2lh = 2(2)(3) + 2(4)(3) + 2(2)(4) = 52$$

PTS: 2 REF: 011029ia STA: A.G.2 TOP: Surface Area

30 ANS: 3

The age of a child does not cause the number of siblings he has, or vice versa.

PTS: 2 REF: 011030ia STA: A.S.14 TOP: Analysis of Data

31 ANS:

16. 12 feet equals 4 yards. $4 \times 4 = 16$.

PTS: 2 REF: 011031ia STA: A.M.2 TOP: Conversions

32 ANS:

$$53. \sin A = \frac{16}{20}$$

$$A \approx 53$$

PTS: 2 REF: 011032ia STA: A.A.43 TOP: Using Trigonometry to Find an Angle

33 ANS:

orchestra: $\frac{3}{26} > \frac{4}{36}$

PTS: 2

REF: 011033ia

STA: A.S.22

TOP: Theoretical Probability

34 ANS:

$-2, 3. \quad x^2 - x = 6$

$x^2 - x - 6 = 0$

$(x-3)(x+2) = 0$

$x = 3 \text{ or } -2$

PTS: 3

REF: 011034ia

STA: A.A.28

TOP: Roots of Quadratics

35 ANS:

81.3, 80, both increase

PTS: 3

REF: 011035ia

STA: A.S.16

TOP: Central Tendency

36 ANS:

0.102. $\frac{(5.3 \times 8.2 \times 4.1) - (5 \times 8 \times 4)}{5.3 \times 8.2 \times 4.1} = \frac{178.16 - 160}{178.16} = 0.102$

PTS: 3

REF: 011036ia

STA: A.M.3

TOP: Error

37 ANS:

15,600,000, 4,368,000. $10 \times 10 \times 10 \times 26 \times 25 \times 24 = 15,600,000$. $10 \times 9 \times 8 \times 26 \times 25 \times 24 = 11,232,000$.
 $15,600,000 - 11,232,000 = 4,368,000$.

PTS: 4

REF: 011037ia

STA: A.N.8

TOP: Permutations

38 ANS:

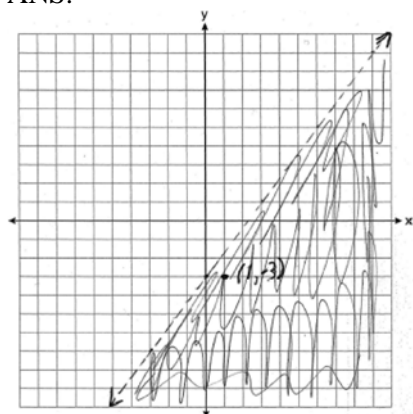
 $(1, -3)$ is in the solution set. $4(1) - 3(-3) > 9$

$4 + 9 > 9$

PTS: 4

REF: 011038ia

STA: A.G.6

TOP: Linear Inequalities

39 ANS:

6, 8, 10. Three consecutive even integers are x , $x + 2$ and $x + 4$. $(x + 2)(x + 4) = 10x + 20$

$$x^2 + 6x + 8 = 10x + 20$$

$$x^2 - 4x - 12 = 0$$

$$(x - 6)(x + 2) = 0$$

$$x = 6$$

PTS: 4

REF: 011039ia

STA: A.A.8

TOP: Writing Quadratics

0610ia
Answer Section

- 1 ANS: 4 PTS: 2 REF: 061001ia STA: A.A.30
TOP: Set Theory
- 2 ANS: 4
 $5 \times 2 \times 3 = 30$
- PTS: 2 REF: 061002ia STA: A.N.7 TOP: Multiplication Counting Principle
- 3 ANS: 3 PTS: 2 REF: 061003ia STA: A.A.13
TOP: Addition and Subtraction of Polynomials KEY: addition
- 4 ANS: 2
 $m = \frac{5-2}{3-(-2)} = \frac{3}{5}$
- PTS: 2 REF: 061004ia STA: A.A.33 TOP: Slope
- 5 ANS: 1 PTS: 2 REF: 061005ia STA: A.G.10
TOP: Identifying the Vertex of a Quadratic Given Graph
- 6 ANS: 3
 $\frac{15}{15+13+12} = \frac{15}{40} = \frac{3}{8}$
- PTS: 2 REF: 061006ia STA: A.S.21 TOP: Experimental Probability
- 7 ANS: 3
 $2(1)+3=5$
- PTS: 2 REF: 061007ia STA: A.A.39 TOP: Linear Equations
- 8 ANS: 3
 $\sqrt{72} - 3\sqrt{2} = \sqrt{36}\sqrt{2} - 3\sqrt{2} = 6\sqrt{2} - 3\sqrt{2} = 3\sqrt{2}$
- PTS: 2 REF: 061008ia STA: A.N.3 TOP: Operations with Radicals
KEY: subtraction
- 9 ANS: 2
 $\tan A = \frac{\text{opposite}}{\text{adjacent}} = \frac{14}{48}$
- PTS: 2 REF: 061009ia STA: A.A.42 TOP: Trigonometric Ratios
- 10 ANS: 1 PTS: 2 REF: 061010ia STA: A.A.40
TOP: Systems of Linear Inequalities
- 11 ANS: 3 PTS: 2 REF: 061011ia STA: A.S.2
TOP: Analysis of Data

12 ANS: 3

$$c + 3d = 8 \quad c = 4d - 6$$

$$4d - 6 + 3d = 8 \quad c = 4(2) - 6$$

$$7d = 14 \quad c = 2$$

$$d = 2$$

PTS: 2

REF: 061012ia

STA: A.A.10

TOP: Solving Linear Systems

13 ANS: 4

PTS: 2

REF: 061013ia

STA: A.G.3

TOP: Defining Functions

14 ANS: 3

$$x^2 - 9 = 0$$

$$(x + 3)(x - 3) = 0$$

$$x = \pm 3$$

PTS: 2

REF: 061014ia

STA: A.A.15

TOP: Undefined Rationals

15 ANS: 2

$y - kx = 7$ may be rewritten as $y = kx + 7$

PTS: 2

REF: 061015ia

STA: A.A.38

TOP: Parallel and Perpendicular Lines

16 ANS: 4

PTS: 2

REF: 061016ia

STA: A.A.2

TOP: Expressions

17 ANS: 3

PTS: 2

REF: 061017ia

STA: A.S.11

TOP: Quartiles and Percentiles

18 ANS: 4

PTS: 2

REF: 061018ia

STA: A.A.12

TOP: Division of Powers

19 ANS: 3

$$\frac{x}{3} + \frac{x+1}{2} = x$$

$$\frac{2x + 3(x+1)}{6} = x$$

$$5x + 3 = 6x$$

$$3 = x$$

PTS: 2

REF: 061019ia

STA: A.A.25

TOP: Solving Equations with Fractional Expressions

20 ANS: 1

$$x^2 - 36 = 5x$$

$$x^2 - 5x - 36 = 0$$

$$(x - 9)(x + 4) = 0$$

$$x = 9$$

PTS: 2

REF: 061020ia

STA: A.A.8

TOP: Writing Quadratics

- 21 ANS: 1 PTS: 2 REF: 061021ia STA: A.A.29
TOP: Set Theory
- 22 ANS: 4 PTS: 2 REF: 061022ia STA: A.S.3
TOP: Analysis of Data
- 23 ANS: 2 PTS: 2 REF: 061023ia STA: A.A.23
TOP: Transforming Formulas
- 24 ANS: 1 PTS: 2 REF: 061024ia STA: A.A.17
TOP: Addition and Subtraction of Rationals
- 25 ANS: 4
$$s = \frac{d}{t} = \frac{150 \text{ m}}{1.5 \text{ min}} \cdot \frac{60 \text{ min}}{1 \text{ hr}} = 6,000 \frac{\text{m}}{\text{hr}}$$
- PTS: 2 REF: 061025ia STA: A.M.1 TOP: Speed
- 26 ANS: 4
 ${}_8P_3 = 336$
- PTS: 2 REF: 061026ia STA: A.N.8 TOP: Permutations
- 27 ANS: 2 PTS: 2 REF: 061027ia STA: A.A.20
TOP: Factoring Polynomials
- 28 ANS: 4 PTS: 2 REF: 061028ia STA: A.G.6
TOP: Linear Inequalities
- 29 ANS: 2
$$A = lw + \frac{\pi r^2}{2} = 6 \cdot 5 + \frac{\pi \cdot 3^2}{2} \approx 44.1$$
- PTS: 2 REF: 061029ia STA: A.G.1 TOP: Compositions of Polygons and Circles
- 30 ANS: 1
$$15000(1.2)^{\frac{6}{3}} = 21,600. \quad 21,600 - 15,000 = 6,600$$
- PTS: 2 REF: 061030ia STA: A.A.9 TOP: Exponential Functions
- 31 ANS:
$$\frac{600 - 592}{592} \approx 0.014$$
- PTS: 2 REF: 061031ia STA: A.M.3 TOP: Relative Error
- 32 ANS:
-6a + 42. distributive
- PTS: 2 REF: 061032ia STA: A.N.1 TOP: Properties of Reals

33 ANS:

$$\sin x = \frac{30}{50}$$

$$x = \sin^{-1} \frac{3}{5}$$

$$x \approx 37$$

PTS: 2

REF: 061033ia

STA: A.A.43

TOP: Using Trigonometry to Find an Angle

34 ANS:

$$-12. 3 \left(\frac{2}{3}x + 3 < -2x - 7 \right)$$

$$x + 9 < -6x - 21$$

$$7x < -30$$

$$x < \frac{-30}{7}$$

PTS: 3

REF: 061034ia

STA: A.A.21

TOP: Interpreting Solutions

35 ANS:

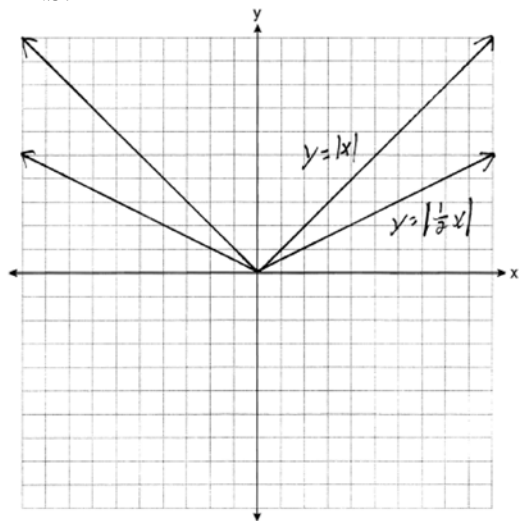

. Graph becomes wider as the coefficient approaches 0.

PTS: 3

REF: 061035ia

STA: A.G.5

TOP: Graphing Absolute Value Functions

36 ANS:

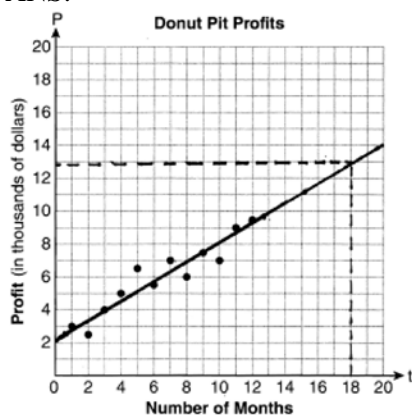

They will not reach their goal in 18 months.

PTS: 3 REF: 061036ia STA: A.S.17 TOP: Scatter Plots

37 ANS:

$$\frac{x^2 + 9x + 14}{x^2 - 49} \div \frac{3x + 6}{x^2 + x - 56} = \frac{(x + 7)(x + 2)}{(x + 7)(x - 7)} \cdot \frac{(x + 8)(x - 7)}{3(x + 2)} = \frac{x + 8}{3}$$

PTS: 4 REF: 061037ia STA: A.A.18 TOP: Multiplication and Division of Rationals

38 ANS:

30, 20, 71-80, 81-90 and 91-100

PTS: 4 REF: 061038ia STA: A.S.9
TOP: Frequency Histograms, Bar Graphs and Tables

39 ANS:

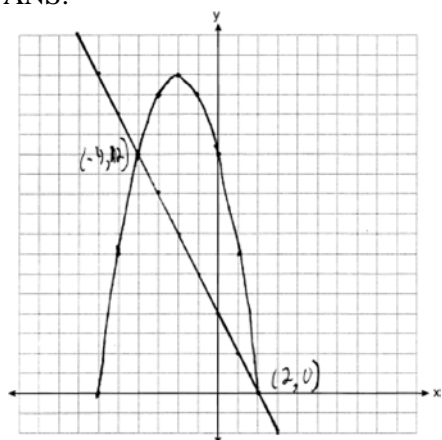

PTS: 4 REF: 061039ia STA: A.G.9 TOP: Quadratic-Linear Systems

0810ia

Answer Section

1 ANS: 3 PTS: 2 REF: 081001ia STA: A.S.7
TOP: Scatter Plots

2 ANS: 1
 $3(2m-1) \leq 4m+7$
 $6m-3 \leq 4m+7$
 $2m \leq 10$
 $m \leq 5$

PTS: 2 REF: 081002ia STA: A.A.24 TOP: Solving Inequalities

3 ANS: 2 PTS: 2 REF: 081003ia STA: A.A.31
TOP: Set Theory

4 ANS: 2
 $\sqrt{5^2+7^2} \approx 8.6$

PTS: 2 REF: 081004ia STA: A.A.45 TOP: Pythagorean Theorem

5 ANS: 2
 $A(-3,8)$ and $B(3,6)$. $m = \frac{8-6}{-3-3} = \frac{2}{-6} = -\frac{1}{3}$

PTS: 2 REF: 081005ia STA: A.A.33 TOP: Slope

6 ANS: 4
 $\frac{9.2 \times 10^6}{2.3 \times 10^2} = 4 \times 10^4$

PTS: 2 REF: 081006ia STA: A.N.4 TOP: Operations with Scientific Notation

7 ANS: 2
Candidate B received 45%. $45\% \times 1860 = 837$

PTS: 2 REF: 081007ia STA: A.N.5 TOP: Percents

8 ANS: 3 PTS: 2 REF: 081008ia STA: A.A.19
TOP: Factoring the Difference of Perfect Squares

9 ANS: 3 PTS: 2 REF: 081009ia STA: A.A.30
TOP: Set Theory

10 ANS: 1
 $2y-2x=10$ axis of symmetry: $x = \frac{-b}{2a} = \frac{-2}{2(1)} = -1$
 $2y = 2x + 10$
 $y = x + 5$

PTS: 2 REF: 081010ia STA: A.G.9 TOP: Quadratic-Linear Systems

11 ANS: 4 PTS: 2 REF: 081011ia STA: A.A.5
TOP: Modeling Equations

12 ANS: 2

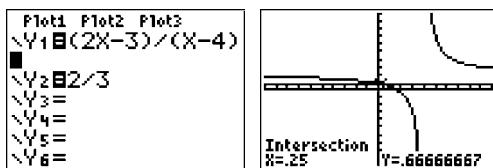

$$\frac{2x-3}{x-4} = \frac{2}{3}$$

$$3(2x-3) = 2(x-4)$$

$$6x-9 = 2x-8$$

$$4x = 1$$

$$x = \frac{1}{4}$$

PTS: 2 REF: 081012ia STA: A.A.26 TOP: Solving Rationals

13 ANS: 4
 $5(x+4) = 5x+20$

PTS: 2 REF: 081013ia STA: A.A.1 TOP: Expressions

14 ANS: 2 PTS: 2 REF: 081014ia STA: A.A.36
TOP: Parallel and Perpendicular Lines

15 ANS: 1 PTS: 2 REF: 081015ia STA: A.G.5
TOP: Graphing Quadratics

16 ANS: 4
 $2x-3y = 9$

$$2(0) - 3(-3) = 9$$

$$0 + 9 = 9$$

PTS: 2 REF: 081016ia STA: A.A.39 TOP: Identifying Points on a Line

17 ANS: 3 PTS: 2 REF: 081017a STA: A.S.14
TOP: Analysis of Data

18 ANS: 3
 $x = \frac{-b}{2a} = \frac{-10}{2(-1)} = 5.$

PTS: 2 REF: 081018ia STA: A.A.41
TOP: Identifying the Vertex of a Quadratic Given Equation

19 ANS: 2

shaded = whole – unshaded

= rectangle-triangle

$$= lw - \frac{1}{2}bh$$

$$= 15 \times 6 - \frac{1}{2} \times 15 \times 4.6$$

$$= 90 - 34.5$$

$$= 55.5$$

PTS: 2

REF: 081019ia

STA: A.G.1

TOP: Compositions of Polygons and Circles

20 ANS: 4

$$\frac{2+3+0+1+3+2+4+0+2+3}{10} = \frac{20}{10} = 2 \quad \frac{x}{10} = 2 + 0.5$$

$$x = 25$$

PTS: 2

REF: 081020ia

STA: A.S.16

TOP: Average Known with Missing Data

21 ANS: 2

$$2(x - 3y = -3)$$

$$2x + y = 8$$

$$2x - 6y = -6$$

$$7y = 14$$

$$y = 2$$

PTS: 2

REF: 081021ia

STA: A.A.10

TOP: Solving Linear Systems

22 ANS: 4

PTS: 2

REF: 081022ia

STA: A.A.29

TOP: Set Theory

23 ANS: 2

$$\left| \frac{55.42 - 50.27}{55.42} \right| \approx 0.093$$

PTS: 2

REF: 081023ia

STA: A.M.3

TOP: Error

24 ANS: 3

$$P(S) \cdot P(M) = P(S \text{ and } M)$$

$$\frac{3}{5} \cdot P(M) = \frac{3}{10}$$

$$P(M) = \frac{1}{2}$$

PTS: 2

REF: 081024ia

STA: A.S.23

TOP: Probability of Independent Events

25 ANS: 4

PTS: 2

REF: 081025ia

STA: A.G.4

TOP: Families of Functions

26 ANS: 2

$$\tan B = \frac{\text{opposite}}{\text{adjacent}} = \frac{8}{15} = 0.5\bar{3}$$

PTS: 2 REF: 081026ia STA: A.A.42 TOP: Trigonometric Ratios

27 ANS: 3

$$\frac{2+x}{5x} - \frac{x-2}{5x} = \frac{2+x-x+2}{5x} = \frac{4}{5x}$$

PTS: 2 REF: 081027ia STA: A.A.17 TOP: Addition and Subtraction of Rationals

28 ANS: 3

$${}_6P_4 = 360$$

PTS: 2 REF: 081028ia STA: A.N.8 TOP: Permutations

29 ANS: 2

$$m = \frac{5-3}{8-1} = \frac{2}{7} \quad y - y_1 = m(x - x_1)$$

$$y - 5 = \frac{2}{7}(x - 8)$$

PTS: 2 REF: 081029ia STA: A.A.35 TOP: Writing Linear Equations

30 ANS: 1

TOP: Expressions

PTS: 2 REF: 081030ia STA: A.A.3

31 ANS:

$$3a^2b^2 - 6a \frac{45a^4b^3 - 90a^3b}{15a^2b} = \frac{45a^4b^3}{15a^2b} - \frac{90a^3b}{15a^2b} = 3a^2b^2 - 6a$$

PTS: 2 REF: 081031ia STA: A.A.14 TOP: Rational Expressions

32 ANS:

$$2,160 \frac{1,200}{25} = \frac{x}{45}$$

$$25x = 54,000$$

$$x = 2,160$$

PTS: 2 REF: 081032ia STA: A.M.1 TOP: Using Rate

33 ANS:

$$-3\sqrt{48} = -3\sqrt{16}\sqrt{3} = -12\sqrt{3}$$

PTS: 2 REF: 081033ia STA: A.N.2 TOP: Simplifying Radicals

34 ANS:

minimum is 120, 1st quartile is 145, median is 292, 3rd quartile is 407, and maximum is 452

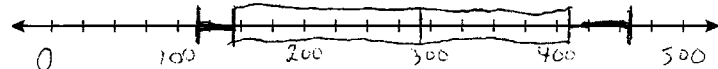

PTS: 3 REF: 081034ia STA: A.S.5 TOP: Box-and-Whisker Plots

35 ANS:

$$80, 136 \quad V = lwh = 10 \cdot 2 \cdot 4 = 80 \quad SA = 2lw + 2hw + 2lh = 2 \cdot 10 \cdot 2 + 2 \cdot 4 \cdot 2 + 2 \cdot 10 \cdot 4 = 136$$

PTS: 3

REF: 081035ia

STA: A.G.2

TOP: Volume

36 ANS:

$$-15, 2 \quad x^2 + 13x - 30 = 0$$

$$(x + 15)(x - 2) = 0$$

$$x = -15, 2$$

PTS: 3

REF: 081036ia

STA: A.A.28

TOP: Roots of Quadratics

37 ANS:

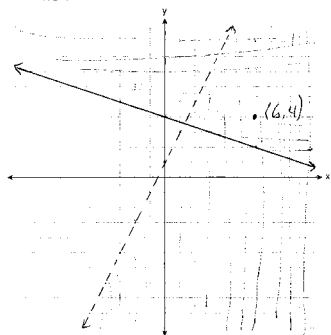

PTS: 4

REF: 081037ia

STA: A.G.7

TOP: Systems of Linear Inequalities

38 ANS:

Hat A, add 1 not green to Hat A, add 11 green to Hat B, and add none to Hat C.

PTS: 4

REF: 081038ia

STA: A.S.22

TOP: Theoretical Probability

39 ANS:

$$84, 71 \quad \sin 50 = \frac{x}{110} \quad \cos 50 = \frac{y}{110}$$

$$x \approx 84 \quad y \approx 71$$

PTS: 4

REF: 081039ia

STA: A.A.44

TOP: Using Trigonometry to Find a Side

0111a
Answer Section

- | | | | | |
|---|--------|---------------|-------------|-------------------------------|
| 1 | ANS: 1 | REF: 011101ia | STA: A.A.31 | TOP: Set Theory |
| 2 | ANS: 4 | REF: 011102ia | STA: A.G.9 | TOP: Quadratic-Linear Systems |
| 3 | ANS: 3 | REF: 011103ia | STA: A.S.12 | TOP: Scatter Plots |
| 4 | ANS: 3 | REF: 011104ia | STA: A.A.1 | TOP: Expressions |
| 5 | ANS: 4 | | | |

In (4), each element in the domain corresponds to a unique element in the range.

REF: 011105ia STA: A.G.3 TOP: Defining Functions

- 6 ANS: 1
 $2(x - 4) = 4(2x + 1)$
 $2x - 8 = 8x + 4$
 $-12 = 6x$
 $-2 = x$

REF: 011106ia STA: A.A.22 TOP: Solving Equations

- 7 ANS: 2
 $\sqrt{18.4^2 - 7^2} \approx 17$

REF: 011107ia STA: A.A.45 TOP: Pythagorean Theorem

- 8 ANS: 2
 $a^3 - 4a = a(a^2 - 4) = a(a - 2)(a + 2)$

REF: 011108ia STA: A.A.19 TOP: Factoring the Difference of Perfect Squares

- 9 ANS: 1
 $\sin x = \frac{\text{opposite}}{\text{hypotenuse}} = \frac{28}{53}$

REF: 011109ia STA: A.A.42 TOP: Trigonometric Ratios

- | | | | | |
|----|--------|---------------|------------|-------------------------------------|
| 10 | ANS: 2 | REF: 011110ia | STA: A.N.6 | TOP: Evaluating Expressions |
| 11 | ANS: 4 | REF: 011111ia | STA: A.G.8 | TOP: Solving Quadratics by Graphing |
| 12 | ANS: 1 | | | |

$$\frac{2x}{3} + \frac{1}{2} = \frac{5}{6}$$

$$\frac{2x}{3} = \frac{1}{3}$$

$$6x = 3$$

$$x = \frac{1}{2}$$

REF: 011112ia STA: A.A.25 TOP: Solving Equations with Fractional Expressions

13 ANS: 3
 $75 - 15 = 60$

REF: 011113ia STA: A.S.6 TOP: Box-and-Whisker Plots

14 ANS: 4 REF: 011114ia STA: A.N.1 TOP: Properties of Reals

15 ANS: 2
 $J - M = 3$
 $8J + 8M = 120$
 $8J - 8M = 24$
 $16J = 144$
 $J = 9$

REF: 011115ia STA: A.A.7 TOP: Writing Linear Systems

16 ANS: 4 REF: 011116ia STA: A.S.1 TOP: Analysis of Data

17 ANS: 3 REF: 011117ia STA: A.G.4 TOP: Graphing Absolute Value Functions

18 ANS: 1
 mean = $81\frac{7}{11}$, median = 81 and mode = 76

REF: 011118ia STA: A.S.4 TOP: Central Tendency

19 ANS: 2 REF: 011119ia STA: A.A.29 TOP: Set Theory

20 ANS: 2
 $\frac{3}{2x} + \frac{7}{4x} = \frac{12x + 14x}{8x^2} = \frac{26x}{8x^2} = \frac{13}{4x}$

REF: 011120ia STA: A.A.17 TOP: Addition and Subtraction of Rationals

21 ANS: 3
 $3\sqrt{2} + \sqrt{8} = 3\sqrt{2} + \sqrt{4}\sqrt{2} = 3\sqrt{2} + 2\sqrt{2} = 5\sqrt{2}$

REF: 011121ia STA: A.N.3 TOP: Operations with Radicals

KEY: addition

22 ANS: 2
 $m = \frac{-A}{B} = \frac{-3}{-7} = \frac{3}{7}$

REF: 011122ia STA: A.A.37 TOP: Slope

23 ANS: 2
 $A = lw + lw + \frac{\pi r^2}{4} = 5 \cdot 3 + 5 \cdot 3 + \frac{\pi \cdot 3^2}{4} \approx 37$

REF: 011123ia STA: A.G.1 TOP: Compositions of Polygons and Circles

KEY: area

24 ANS: 3

$$\frac{(10w^3)^2}{5w} = \frac{100w^6}{5w} = 20w^5$$

REF: 011124ia STA: A.A.12 TOP: Powers of Powers

25 ANS: 4

$$\frac{ey}{n} + k = t$$

$$\frac{ey}{n} = t - k$$

$$y = \frac{n(t - k)}{e}$$

REF: 011125ia STA: A.A.23 TOP: Transforming Formulas

26 ANS: 1 REF: 011126ia STA: A.A.13 TOP: Addition and Subtraction of Polynomials

KEY: subtraction

27 ANS: 1

$$x = \frac{-b}{2a} = \frac{-6}{2(-1)} = 3.$$

REF: 011127ia STA: A.A.41 TOP: Identifying the Vertex of a Quadratic Given Equation

28 ANS: 2

$$x^2 - 2x - 15 = 0$$

$$(x - 5)(x + 3) = 0$$

$$x = 5 \quad x = -3$$

REF: 011128ia STA: A.A.28 TOP: Roots of Quadratics

29 ANS: 3

$$\frac{3 + 2 + 4 + 3}{20} = \frac{12}{20}$$

REF: 011129ia STA: A.S.21 TOP: Experimental Probability

30 ANS: 1

$$\frac{x^2 - x - 6}{x^2 - 5x + 6} = \frac{(x - 3)(x + 2)}{(x - 3)(x + 2)} = \frac{x + 2}{x - 2}$$

REF: 011130ia STA: A.A.16 TOP: Rational Expressions

KEY: $a > 0$

31 ANS:

$$5. \quad 48 \text{ inches} \times \frac{1 \text{ yard}}{36 \text{ inches}} = \frac{4}{3} \text{ yards} \times \$3.75 = \$5.00$$

REF: 011131ia STA: A.M.2 TOP: Conversions

32 ANS:

$$\frac{1375}{1600} \cdot \frac{40^2 - 15^2}{40^2} = \frac{1375}{1600}$$

REF: 011132ia STA: A.S.20 TOP: Theoretical Probability

33 ANS:

$$2.1. \cos 65 = \frac{x}{5}$$

$$x \approx 2.1$$

REF: 011133ia STA: A.A.44 TOP: Using Trigonometry to Find a Side

34 ANS:

$$y = \frac{3}{4}x + 10. \quad y = mx + b$$

$$4 = \frac{3}{4}(-8) + b$$

$$4 = -6 + b$$

$$10 = b$$

REF: 011134ia STA: A.A.34 TOP: Writing Linear Equations

35 ANS:

Interval	Tally	Frequency
51-60		2
61-70		2
71-80		4
81-90		6
91-100		4

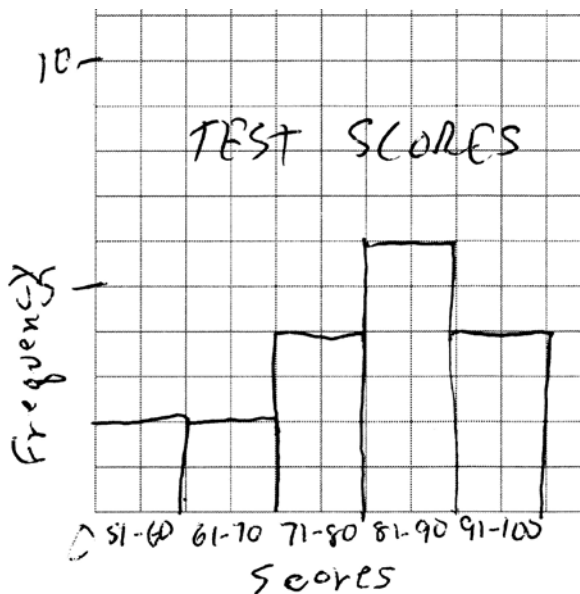

REF: 011135ia STA: A.S.5 TOP: Frequency Histograms, Bar Graphs and Tables

36 ANS:

$$4, -5. \quad \frac{x+2}{6} = \frac{3}{x-1}$$

$$(x+2)(x-1) = 18$$

$$x^2 - x + 2x - 2 = 18$$

$$x^2 + x - 20 = 0$$

$$(x+5)(x-4) = 0$$

$$x = -5 \text{ or } 4$$

REF: 011136ia STA: A.A.26 TOP: Solving Rationals

37 ANS:

$$0.029. \quad \frac{[2\pi(5.1)^2 + 2\pi(5.1)(15.1)] - [2\pi(5)^2 + 2\pi(5)(15)]}{2\pi(5.1)^2 + 2\pi(5.1)(15.1)} \approx \frac{647.294 - 628.319}{647.294} \approx 0.029$$

REF: 011137ia STA: A.M.3 TOP: Error KEY: volume and surface area

38 ANS:

$$24,435.19. \quad 30000(.95)^4 \approx 24435.19$$

REF: 011138ia STA: A.A.9 TOP: Exponential Functions

39 ANS:

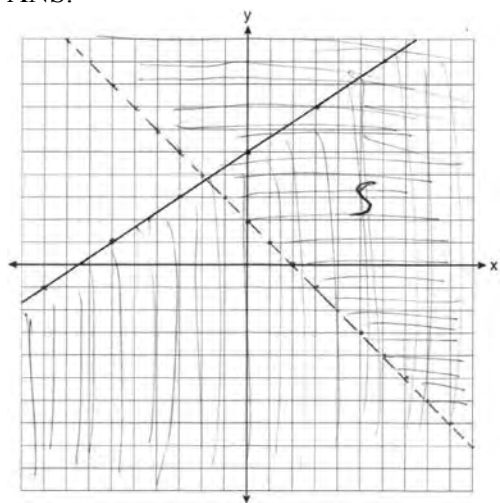

REF: 011139ia STA: A.G.7 TOP: Systems of Linear Inequalities

0611ia
Answer Section

- 1 ANS: 3 PTS: 2 REF: 061101ia STA: A.A.19
TOP: Factoring the Difference of Perfect Squares
- 2 ANS: 3
 $10^2 + 10^2 = c^2$
 $c^2 = 200$
 $c \approx 14.1$
- PTS: 2 REF: 061102ia STA: A.A.45 TOP: Pythagorean Theorem
- 3 ANS: 1 PTS: 2 REF: 061103ia STA: A.A.12
TOP: Division of Powers
- 4 ANS: 3
 $P(\text{odd}) = \frac{3}{6}, P(\text{prime}) = \frac{3}{6}, P(\text{perfect square}) = \frac{2}{6}, P(\text{even}) = \frac{3}{6}$
- PTS: 2 REF: 061104ia STA: A.S.22 TOP: Geometric Probability
- 5 ANS: 2 PTS: 2 REF: 061105ia STA: A.A.20
TOP: Factoring Polynomials
- 6 ANS: 3
 $3\sqrt{250} = 3\sqrt{25}\sqrt{10} = 15\sqrt{10}$
- PTS: 2 REF: 061106ia STA: A.N.2 TOP: Simplifying Radicals
- 7 ANS: 1
Asking school district employees about a school board candidate produces the most bias.
- PTS: 2 REF: 061107ia STA: A.S.3 TOP: Analysis of Data
- 8 ANS: 2
 $\sin 57 = \frac{x}{8}$
 $x \approx 6.7$
- PTS: 2 REF: 061108ia STA: A.A.44 TOP: Using Trigonometry to Find a Side
- 9 ANS: 4
 ${}_5P_5 = 5 \times 4 \times 3 \times 2 \times 1 = 120$
- PTS: 2 REF: 061109ia STA: A.N.8 TOP: Permutations
- 10 ANS: 3
 $m = \frac{6-4}{3-(-2)} = \frac{2}{5}$
- PTS: 2 REF: 061110ia STA: A.A.33 TOP: Slope
- 11 ANS: 4 PTS: 2 REF: 061111ia STA: A.G.4
TOP: Families of Functions

- 12 ANS: 4 PTS: 2 REF: 061112ia STA: A.A.36
TOP: Parallel and Perpendicular Lines
- 13 ANS: 2 PTS: 2 REF: 061113ia STA: A.G.5
TOP: Graphing Quadratic Functions
- 14 ANS: 1 PTS: 2 REF: 061114ia STA: A.A.43
TOP: Using Trigonometry to Find an Angle
- 15 ANS: 2 PTS: 2 REF: 061115ia STA: A.S.7
TOP: Scatter Plots

16 ANS: 2

In (2), each element in the domain corresponds to a unique element in the range.

PTS: 2 REF: 061116ia STA: A.G.3 TOP: Defining Functions

17 ANS: 1

$$\frac{12.8 + 17.2}{3 + 5} = 3.75$$

PTS: 2 REF: 061117ia STA: A.M.1 TOP: Speed

18 ANS: 2

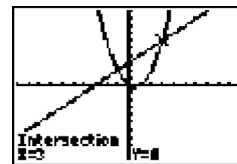

$x^2 - x = x + 3$. Since $y = x + 3$, the solutions are (3,6) and (-1,2).

$$x^2 - 2x - 3 = 0$$

$$(x - 3)(x + 1) = 0$$

$$x = 3 \text{ or } -1$$

PTS: 2 REF: 061118ia STA: A.A.11 TOP: Quadratic-Linear Systems

19 ANS: 3 PTS: 2 REF: 061119ia STA: A.A.2

TOP: Expressions

20 ANS: 3

$$\frac{(12.3 \times 11.9) - (12.2 \times 11.8)}{12.3 \times 11.9} \approx 0.0165$$

PTS: 2 REF: 061120ia STA: A.M.3 TOP: Error

KEY: area

21 ANS: 2 PTS: 2 REF: 061121ia STA: A.A.3

TOP: Expressions

22 ANS: 2 PTS: 2 REF: 061122ia STA: A.S.14

TOP: Analysis of Data

23 ANS: 4 PTS: 2 REF: 061123ia STA: A.A.31

TOP: Set Theory

24 ANS: 2

$$20000(.88)^3 = 13629.44$$

PTS: 2 REF: 061124ia STA: A.A.9 TOP: Exponential Functions

- 25 ANS: 4
 $x^2 - 4x - 12 = 0$
 $(x - 6)(x + 2) = 0$
 $x = 6$ $x = -2$
- PTS: 2 REF: 061125ia STA: A.A.15 TOP: Undefined Rationals
- 26 ANS: 1
 $f + m = 53$
 $f - m = 25$
 $2m = 28$
 $m = 14$
- PTS: 2 REF: 061126ia STA: A.A.7 TOP: Writing Linear Systems
- 27 ANS: 2 PTS: 2 REF: 061127ia STA: A.N.4
TOP: Operations with Scientific Notation
- 28 ANS: 2 PTS: 2 REF: 061128ia STA: A.A.29
TOP: Set Theory
- 29 ANS: 4
 $\frac{7}{12x} - \frac{y}{6x^2} = \frac{42x^2 - 12xy}{72x^3} = \frac{6x(7x - 2y)}{72x^3} = \frac{7x - 2y}{12x^2}$
- PTS: 2 REF: 061129ia STA: A.A.17 TOP: Addition and Subtraction of Rationals
- 30 ANS: 4 PTS: 2 REF: 061130ia STA: A.A.13
TOP: Addition and Subtraction of Polynomials KEY: subtraction
- 31 ANS:
 $\frac{x^2 - 5x - 24}{x - 8} = \frac{(x - 8)(x + 3)}{x - 8} = x + 3$
- PTS: 2 REF: 061131ia STA: A.A.14 TOP: Division of Polynomials
- 32 ANS:
(1) Distributive; (2) Commutative
- PTS: 2 REF: 061132ia STA: A.N.1 TOP: Identifying Properties
- 33 ANS:
 $x = 1$; (1, -5)
- PTS: 2 REF: 061133ia STA: A.G.10 TOP: Identifying the Vertex of a Quadratic Given Graph
- 34 ANS:
12, 7. Both the median and the mode will increase.
- PTS: 3 REF: 061134ia STA: A.S.16 TOP: Central Tendency

35 ANS:

$$0.65x + 35 \leq 45$$

$$0.65x \leq 10$$

$$x \leq 15$$

PTS: 3

REF: 061135ia

STA: A.A.6

TOP: Modeling Inequalities

36 ANS:

$$2(x+3)(x-4) + 2(5)(x-4) + 2(x+3)(5)$$

$$2(x^2 - 4x + 3x - 12) + 10(x-4) + 10(x+3)$$

$$2x^2 - 2x - 24 + 10x - 40 + 10x + 30$$

$$2x^2 + 18x - 34$$

PTS: 3

REF: 061136ia

STA: A.G.2

TOP: Surface Area

37 ANS:

$$-\frac{9}{4}; \quad \frac{3}{4} = \frac{-(x+11)}{4x} + \frac{1}{2x}$$

$$\frac{3}{4} = \frac{-x-11}{4x} + \frac{2}{4x}$$

$$\frac{3}{4} = \frac{-x-9}{4x}$$

$$12x = -4x - 36$$

$$16x = -36$$

$$x = -\frac{9}{4}$$

PTS: 4

REF: 061137ia

STA: A.A.26

TOP: Solving Rationals

38 ANS:

(T,J,F), (T,J,N), (T,K,F), (T,K,N), (T,C,F), (T,C,N), (B,J,F), (B,J,N), (B,K,F), (B,K,N), (B,C,F), (B,C,N), (S,J,F), (S,J,N), (S,K,F), (S,K,N), (S,C,F), (S,C,N). 3, 12.

PTS: 4

REF: 061138ia

STA: A.S.19

TOP: Sample Space

39 ANS:

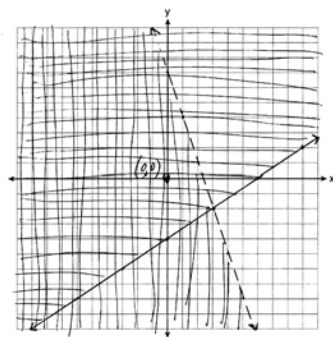

PTS: 4

REF: 061139ia

STA: A.G.7

TOP: Systems of Linear Inequalities

0811ia

Answer Section

1 ANS: 4

$$\frac{150}{20} = \frac{x}{30}$$

$$20x = 4500$$

$$x = 225$$

PTS: 2 REF: 081101ia STA: A.N.5 TOP: Direct Variation

2 ANS: 1 PTS: 2 REF: 081102ia STA: A.S.12

TOP: Scatter Plots

3 ANS: 3 PTS: 2 REF: 081103ia STA: A.A.30

TOP: Set Theory

4 ANS: 2 PTS: 2 REF: 081104ia STA: A.S.14

TOP: Analysis of Data

5 ANS: 3

$$V = \pi r^2 h = \pi \cdot 5^2 \cdot 2.3 \approx 180.6$$

PTS: 2 REF: 081105ia STA: A.G.2 TOP: Volume

6 ANS: 2 PTS: 2 REF: 081106ia STA: A.S.6

TOP: Box-and-Whisker Plots

7 ANS: 4 PTS: 2 REF: 081107ia STA: A.A.5

TOP: Modeling Inequalities

8 ANS: 1

$$y = mx + b$$

$$5 = (-2)(1) + b$$

$$b = 7$$

PTS: 2 REF: 081108ia STA: A.A.34 TOP: Writing Linear Equations

9 ANS: 3

$$2x - 5y = 11 \quad 2x - 5(-1) = 11$$

$$-2x + 3y = -9 \quad 2x = 6$$

$$-2y = 2 \quad x = 3$$

$$y = -1$$

PTS: 2 REF: 081109ia STA: A.A.10 TOP: Solving Linear Systems

10 ANS: 1 PTS: 2 REF: 081110ia STA: A.A.1

TOP: Expressions

11 ANS: 2 PTS: 2 REF: 081111ia STA: A.G.10

TOP: Identifying the Vertex of a Quadratic Given Graph

12 ANS: 2

$$\tan ABC = \frac{\text{opposite}}{\text{adjacent}} = \frac{5}{12}$$

PTS: 2

REF: 081112ia

STA: A.A.42

TOP: Trigonometric Ratios

13 ANS: 1

$$-3(-4)^2(2) + 4(-4) = -96 - 16 = -112$$

PTS: 2

REF: 081113ia

STA: A.N.6

TOP: Evaluating Expressions

14 ANS: 4

$$-3x(x-4) - 2x(x+3) = -3x^2 + 12x - 2x^2 - 6x = -5x^2 + 6x$$

PTS: 2

REF: 081114ia

STA: A.A.13

TOP: Addition and Subtraction of Monomials

15 ANS: 1

PTS: 2

REF: 081115ia

STA: A.A.32

TOP: Slope

16 ANS: 2

$$l(l-3) = 40$$

$$l^2 - 3l - 40 = 0$$

$$(l-8)(l+5) = 0$$

$$l = 8$$

PTS: 2

REF: 081116ia

STA: A.A.8

TOP: Geometric Applications of Quadratics

17 ANS: 3

PTS: 2

REF: 081117ia

STA: A.A.29

TOP: Set Theory

18 ANS: 3

PTS: 2

REF: 081118ia

STA: A.G.4

TOP: Families of Functions

19 ANS: 1

$$b = 2j + 4 \quad 2j + 4 = 31 - j$$

$$b + j = 31 \quad 3j = 27$$

$$b = 31 - j \quad j = 9$$

PTS: 2

REF: 081119ia

STA: A.A.7

TOP: Writing Linear Systems

20 ANS: 2

$$x^2 - 5x + 6 = 0$$

$$(x-3)(x-2) = 0$$

$$x = 3 \quad x = 2$$

PTS: 2

REF: 081120ia

STA: A.A.28

TOP: Roots of Quadratics

- 21 ANS: 4
 $-6x - 17 \geq 8x + 25$
 $-42 \geq 14x$
 $-3 \geq x$
- PTS: 2 REF: 081121ia STA: A.A.24 TOP: Solving Inequalities
- 22 ANS: 4
 The other situations are quantitative.
- PTS: 2 REF: 081122ia STA: A.S.1 TOP: Analysis of Data
- 23 ANS: 2
 $\left| \frac{13.5 - 12.8}{13.5} \right| \approx 0.093$
- PTS: 2 REF: 081123ia STA: A.M.3 TOP: Error
 KEY: area
- 24 ANS: 2
 $2000(1 + 0.04)^3 \approx 2249$
- PTS: 2 REF: 081124ia STA: A.A.9 TOP: Exponential Functions
- 25 ANS: 3
 $P(O) = \frac{5}{10}, P(P) = \frac{4}{10}, P(\leq 5) = \frac{6}{10}, P(3) = \frac{4}{10}$
- PTS: 2 REF: 081125ia STA: A.S.22 TOP: Theoretical Probability
- 26 ANS: 2
 $\cos 38 = \frac{10}{x}$
 $x = \frac{10}{\cos 38} \approx 12.69$
- PTS: 2 REF: 081126ia STA: A.A.44 TOP: Using Trigonometry to Find a Side
- 27 ANS: 2 PTS: 2 REF: 081127ia STA: A.A.40
 TOP: Systems of Linear Inequalities
- 28 ANS: 1
 $7 + 8 + 7 + \frac{12\pi}{2} = 22 + 6\pi$
- PTS: 2 REF: 081128ia STA: A.G.1 TOP: Compositions of Polygons and Circles
 KEY: perimeter
- 29 ANS: 2
 $36x^2 - 100y^6 = 4(9x^2 - 25y^6) = 4(3x + 5y^3)(3x - 5y^3)$
- PTS: 2 REF: 081129ia STA: A.A.19
 TOP: Factoring the Difference of Perfect Squares

30 ANS: 4

$$\frac{x}{x+4} \div \frac{2x}{x^2-16} = \frac{x}{x+4} \cdot \frac{x^2-16}{2x} = \frac{1}{x+4} \cdot \frac{(x+4)(x-4)}{2} = \frac{x-4}{2}$$

PTS: 2

REF: 081130ia

STA: A.A.18

TOP: Multiplication and Division of Rationals

31 ANS:

$$bc + ac = ab$$

$$c(b+a) = ab$$

$$c = \frac{ab}{b+a}$$

PTS: 2

REF: 081131ia

STA: A.A.23

TOP: Transforming Formulas

32 ANS:

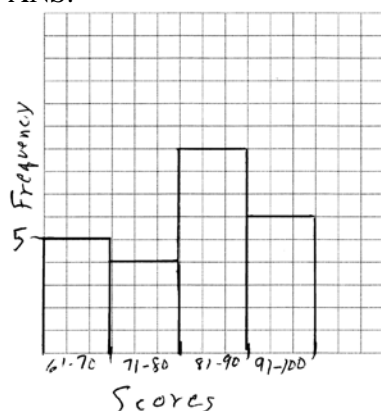

PTS: 2

REF: 081132ia

STA: A.S.5

TOP: Frequency Histograms, Bar Graphs and Tables

KEY: frequency histograms

33 ANS:

$$77120 + 33500 = 110620 \text{ sq. ft.} \times \frac{1 \text{ acre}}{43560 \text{ sq. ft.}} \approx 2.54 \text{ acres}$$

PTS: 2

REF: 081133ia

STA: A.M.2

TOP: Conversions

34 ANS:

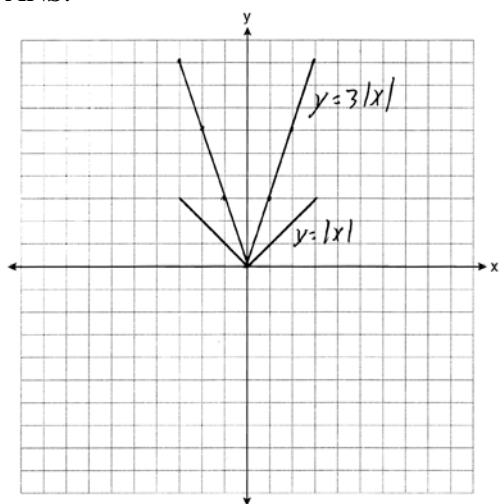

The graph becomes steeper.

PTS: 3

REF: 081134ia

STA: A.G.5

TOP: Graphing Absolute Value Functions

35 ANS:

$$41.8. \sin x = \frac{8}{12}$$

$$A \approx 41.8$$

PTS: 3

REF: 081135ia

STA: A.A.43

TOP: Using Trigonometry to Find an Angle

36 ANS:

$$-2\sqrt{3} \frac{16\sqrt{21}}{2\sqrt{7}} - 5\sqrt{12} = 8\sqrt{3} - 5\sqrt{4}\sqrt{3} = 8\sqrt{3} - 10\sqrt{3} = -2\sqrt{3}$$

PTS: 3

REF: 081136ia

STA: A.N.3

TOP: Operations with Radicals

37 ANS:

$$\frac{4}{12} \times \frac{2}{11} \times \frac{1}{10} = \frac{8}{1320} \quad \frac{6}{12} \times \frac{5}{11} \times \frac{4}{10} + \frac{4}{12} \times \frac{3}{11} \times \frac{2}{10} = \frac{120}{1320} + \frac{24}{1320} = \frac{144}{1320}$$

PTS: 4

REF: 081137ia

STA: A.S.23

TOP: Theoretical Probability

KEY: dependent events

38 ANS:

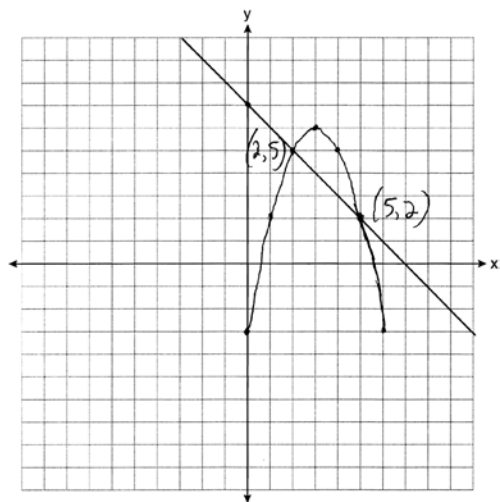

PTS: 4

REF: 081138ia

STA: A.G.9

TOP: Quadratic-Linear Systems

39 ANS:

$$\frac{m}{5} + \frac{3(m-1)}{2} = 2(m-3)$$

$$\frac{2m}{10} + \frac{15(m-1)}{10} = 2m - 6$$

$$\frac{17m-15}{10} = 2m-6$$

$$17m-15 = 20m-60$$

$$45 = 3m$$

$$15 = m$$

PTS: 4

REF: 081139ia

STA: A.A.25

TOP: Solving Equations with Fractional Expressions

0112ia

Answer Section

1 ANS: 2 REF: 011201ia STA: A.A.19

TOP: Factoring the Difference of Perfect Squares

2 ANS: 1 REF: 011202ia STA: A.A.9 TOP: Exponential Functions

3 ANS: 3

$$2\sqrt{45} = 2\sqrt{9}\sqrt{5} = 6\sqrt{5}$$

REF: 011203ia STA: A.N.2 TOP: Simplifying Radicals

4 ANS: 3 REF: 011204ia STA: A.G.3 TOP: Defining Functions

5 ANS: 3 REF: 011205ia STA: A.A.1 TOP: Expressions

6 ANS: 4

The transformation is a reflection in the x -axis.

REF: 011206ia STA: A.G.5 TOP: Graphing Absolute Value Functions

7 ANS: 1 REF: 011207ia STA: A.G.9 TOP: Quadratic-Linear Systems

8 ANS: 3

$$b = 3 + d \quad (3 + d)d = 40$$

$$bd = 40 \quad d^2 + 3d - 40 = 0$$

$$(d + 8)(d - 5) = 0$$

$$d = 5$$

REF: 011208ia STA: A.A.8 TOP: Writing Quadratics

9 ANS: 2

$$\left| \frac{(2.6 \times 6.9) - (2.5 \times 6.8)}{(2.6 \times 6.9)} \right| \approx 0.052$$

REF: 011209ia STA: A.M.3 TOP: Error KEY: area

10 ANS: 1 REF: 011210ia STA: A.G.6 TOP: Linear Inequalities

11 ANS: 2

The other sets of data are qualitative.

REF: 011211ia STA: A.S.1 TOP: Analysis of Data

12 ANS: 2 REF: 011212ia STA: A.S.23 TOP: Theoretical Probability

KEY: independent events

13 ANS: 1 REF: 011213ia STA: A.A.13 TOP: Addition and Subtraction of Polynomials

KEY: addition

14 ANS: 1

$$x^2 + 5x - 6 = 0$$

$$(x + 6)(x - 1) = 0$$

$$x = -6, 1$$

REF: 011214ia STA: A.A.15 TOP: Undefined Rationals

15 ANS: 4

$$m = \frac{-3-1}{2-5} = \frac{-4}{-3} = \frac{4}{3}$$

REF: 011215ia STA: A.A.33 TOP: Slope

16 ANS: 4

$$\frac{(4x^3)^2}{2x} = \frac{16x^6}{2x} = 8x^5$$

REF: 011216ia STA: A.A.12 TOP: Powers of Powers

17 ANS: 1

If the area of the square is 36, a side is 6, the diameter of the circle is 6, and its radius is 3. $A = \pi r^2 = 3^2 \pi = 9\pi$

REF: 011217ia STA: A.G.1 TOP: Compositions of Polygons and Circles

KEY: area

18 ANS: 4

$$3y + 2x = 8$$

$$3(-2) + 2(7) = 8$$

$$-6 + 14 = 8$$

REF: 011218ia STA: A.A.39 TOP: Identifying Points on a Line

19 ANS: 1

$$x = \frac{-b}{2a} = \frac{-(-3)}{2(2)} = \frac{3}{4}$$

REF: 011219ia STA: A.A.41 TOP: Identifying the Vertex of a Quadratic Given Equation

20 ANS: 3 REF: 011220ia STA: A.S.6 TOP: Box-and-Whisker Plots

21 ANS: 1

$$\sqrt{1700^2 - 1300^2} \approx 1095$$

REF: 011221ia STA: A.A.45 TOP: Pythagorean Theorem

22 ANS: 4 REF: 011222ia STA: A.A.29 TOP: Set Theory

23 ANS: 1

$$3x^2 - 27x = 0$$

$$3x(x-9) = 0$$

$$x = 0, 9$$

REF: 011223ia STA: A.A.28 TOP: Roots of Quadratics

24 ANS: 3 REF: 011224ia STA: A.N.1 TOP: Properties of Reals

25 ANS: 4 REF: 011225ia STA: A.A.31 TOP: Set Theory

26 ANS: 3

$$\tan PLM = \frac{\text{opposite}}{\text{adjacent}} = \frac{4}{3}$$

REF: 011226ia STA: A.A.42 TOP: Trigonometric Ratios

27 ANS: 2 REF: 011227ia STA: A.A.3 TOP: Expressions

28 ANS: 1

$$s = \frac{2x+t}{r}$$

$$rs = 2x+t$$

$$rs - t = 2x$$

$$\frac{rs-t}{2} = x$$

REF: 011228ia STA: A.A.23 TOP: Transforming Formulas

29 ANS: 4 REF: 011229ia STA: A.S.8 TOP: Scatter Plots

30 ANS: 2

$$\frac{2y}{y+5} + \frac{10}{y+5} = \frac{2y+10}{y+5} = \frac{2(y+5)}{y+5} = 2$$

REF: 011230ia STA: A.A.17 TOP: Addition and Subtraction of Rationals

31 ANS:

$$147.75 \quad 2 \times 5.5 \times 3 + 2 \times 6.75 \times 3 + 2 \times 5.5 \times 6.75 = 147.75$$

REF: 011231ia STA: A.G.2 TOP: Surface Area

32 ANS:

$$\frac{6}{25} \cdot \frac{25 - (11 + 5 + 3)}{25}$$

REF: 011232ia STA: A.S.21 TOP: Experimental Probability

33 ANS:

$$\frac{x-1}{x+2} \cdot \frac{x^2-1}{x^2+3x+2} = \frac{(x+1)(x-1)}{(x+2)(x+1)}$$

REF: 011233ia STA: A.A.16 TOP: Rational Expressions

KEY: $a > 0$

34 ANS:

$$2(x-4) \geq \frac{1}{2}(5-3x)$$

$$4(x-4) \geq 5-3x$$

$$4x-16 \geq 5-3x$$

$$7x \geq 21$$

$$x \geq 3$$

REF: 011234ia STA: A.A.24 TOP: Solving Inequalities

35 ANS:

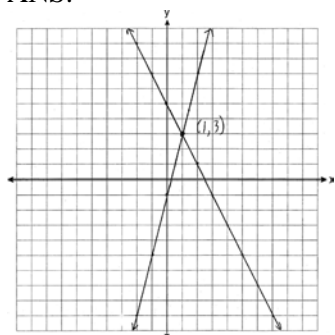

REF: 011235ia STA: A.G.7 TOP: Solving Linear Systems

36 ANS:

The turtle won by .5 minutes. Turtle: $\frac{d}{s} = \frac{100}{20} = 5$. Rabbit: $\frac{d}{s} = \frac{100}{40} = 2.5 + 3 = 5.5$

REF: 011236ia STA: A.M.1 TOP: Speed

37 ANS:

$$7, 9, 11. \quad x + (x+2) + (x+4) = 5(x+2) - 18$$

$$3x + 6 = 5x - 8$$

$$14 = 2x$$

$$7 = x$$

REF: 011237ia STA: A.A.6 TOP: Modeling Equations

38 ANS:

(W,H,A), (W,H,S), (W,T,A), (W,T,S), (W,B,A), (W,B,S), (R,H,A), (R,H,S), (R,T,A), (R,T,S), (R,B,A), (R,B,S).
8, 3

REF: 011238ia STA: A.S.19 TOP: Sample Space

39 ANS:

$$259.99 \times 1.07 - 259.99(1 - 0.3) \times 1.07 = 83.46$$

REF: 011239ia STA: A.N.5 TOP: Percents

0612ia

Answer Section

1 ANS: 1

$$\frac{\text{distance}}{\text{time}} = \frac{350.7}{4.2} = 83.5$$

PTS: 2 REF: 061201ia STA: A.M.1 TOP: Speed

2 ANS: 2

People at a gym or football game and members of a soccer team are more biased towards sports.

PTS: 2 REF: 061202ia STA: A.S.3 TOP: Analysis of Data

3 ANS: 4

PTS: 2 REF: 061203ia STA: A.A.14

TOP: Division of Polynomials

4 ANS: 1

PTS: 2 REF: 061204ia STA: A.A.1

TOP: Expressions

5 ANS: 2

PTS: 2 REF: 061205ia STA: A.S.12

TOP: Scatter Plots

6 ANS: 3

PTS: 2 REF: 061206ia STA: A.S.2

TOP: Analysis of Data

7 ANS: 4

$$\frac{95000}{125000} = .76$$

PTS: 2 REF: 061207ia STA: A.S.11 TOP: Quartiles and Percentiles

8 ANS: 3

PTS: 2 REF: 061208ia STA: A.A.31

TOP: Set Theory

9 ANS: 1

PTS: 2 REF: 061209ia STA: A.G.3

TOP: Defining Functions

10 ANS: 3

$$(3x + 2)(x - 7) = 3x^2 - 21x + 2x - 14 = 3x^2 - 19x - 14$$

PTS: 2 REF: 061210ia STA: A.A.13 TOP: Multiplication of Polynomials

11 ANS: 3

$$5x < 55$$

$$x < 11$$

PTS: 2 REF: 061211ia STA: A.A.6 TOP: Modeling Inequalities

12 ANS: 4

$$m = \frac{-A}{B} = \frac{-(-3)}{2} = \frac{3}{2}$$

PTS: 2 REF: 061212ia STA: A.A.37 TOP: Slope

13 ANS: 2

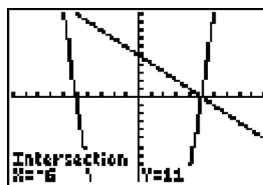

$$y = -x + 5. \quad -x + 5 = x^2 - 25 \quad . \quad y = -(-6) + 5 = 11.$$

$$0 = x^2 + x - 30 \quad y = -5 + 5 = 0$$

$$0 = (x + 6)(x - 5)$$

$$x = -6, 5$$

PTS: 2 REF: 061213ia STA: A.A.11 TOP: Quadratic-Linear Systems

14 ANS: 3

$$x = \frac{-b}{2a} = \frac{-24}{2(-2)} = 6. \quad y = -2(6)^2 + 24(6) - 100 = -28$$

PTS: 2 REF: 061214ia STA: A.A.41
TOP: Identifying the Vertex of a Quadratic Given Equation

15 ANS: 1

$$k = am + 3mx$$

$$k = m(a + 3x)$$

$$\frac{k}{a + 3x} = m$$

PTS: 2 REF: 061215ia STA: A.A.23 TOP: Transforming Formulas

16 ANS: 2

$$\frac{x^2 - 3x - 10}{x^2 - 25} = \frac{(x - 5)(x + 2)}{(x + 5)(x - 5)} = \frac{x + 2}{x + 5}$$

PTS: 2 REF: 061216ia STA: A.A.16 TOP: Rational Expressions
KEY: $a > 0$ 17 ANS: 3 PTS: 2 REF: 061217ia STA: A.A.29
TOP: Set Theory18 ANS: 3 PTS: 2 REF: 061218ia STA: A.S.20
TOP: Geometric Probability

19 ANS: 3

$$\frac{3^6}{3^1} = 3^5$$

PTS: 2 REF: 061219ia STA: A.A.12 TOP: Division of Powers

20 ANS: 1 PTS: 2 REF: 061220ia STA: A.A.17
TOP: Addition and Subtraction of Rationals21 ANS: 4 PTS: 2 REF: 061221ia STA: A.G.4
TOP: Identifying the Equation of a Graph

- 22 ANS: 4 PTS: 2 REF: 061222ia STA: A.A.40
TOP: Systems of Linear Inequalities
- 23 ANS: 2
 $13^2 + 13^2 = x^2$
 $338 = x^2$
 $\sqrt{338} = x$
 $18 \approx x$
- PTS: 2 REF: 061223ia STA: A.A.45 TOP: Pythagorean Theorem
- 24 ANS: 4
If $m\angle C = 90$, then \overline{AB} is the hypotenuse, and the triangle is a 3-4-5 triangle.
- PTS: 2 REF: 061224ia STA: A.A.42 TOP: Trigonometric Ratios
- 25 ANS: 3 PTS: 2 REF: 061225ia STA: A.A.5
TOP: Modeling Equations
- 26 ANS: 4 PTS: 2 REF: 061226ia STA: A.A.13
TOP: Addition and Subtraction of Polynomials KEY: subtraction
- 27 ANS: 4
 $3x^3 - 33x^2 + 90x = 3x(x^2 - 11x + 30) = 3x(x - 5)(x - 6)$
- PTS: 2 REF: 061227ia STA: A.A.20 TOP: Factoring Polynomials
- 28 ANS: 1
 $\frac{3}{4} \times 5 = \frac{15}{4}$ teaspoons $\times \frac{1 \text{ tablespoon}}{3 \text{ teaspoons}} = \frac{5}{4} = 1 \frac{1}{4}$ tablespoon
- PTS: 2 REF: 061228ia STA: A.M.2 TOP: Conversions
KEY: dimensional analysis
- 29 ANS: 2 PTS: 2 REF: 061229ia STA: A.A.9
TOP: Exponential Functions
- 30 ANS: 3 PTS: 2 REF: 061230ia STA: A.S.9
TOP: Frequency Histograms, Bar Graphs and Tables
- 31 ANS:
2. Subtracting the equations: $3y = 6$
 $y = 2$
- PTS: 2 REF: 061231ia STA: A.A.10 TOP: Solving Linear Systems
- 32 ANS:
White. There are 31 white blocks, 30 red blocks and 29 blue blocks.
- PTS: 2 REF: 061232ia STA: A.S.22 TOP: Theoretical Probability

33 ANS:

$$\frac{8100 - 7678.5}{7678.5} \approx 0.055$$

PTS: 2 REF: 061233ia STA: A.M.3 TOP: Error
 KEY: area

34 ANS:

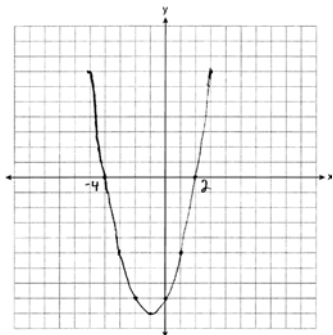

PTS: 3 REF: 061234ia STA: A.G.8 TOP: Solving Quadratics by Graphing

35 ANS:

78. $\cos x = \frac{6}{28}$
 $x \approx 78$

PTS: 3 REF: 061235ia STA: A.A.43 TOP: Using Trigonometry to Find an Angle

36 ANS:

$$6\sqrt{3} \frac{3\sqrt{75} + \sqrt{27}}{3} = \frac{3\sqrt{25}\sqrt{3} + \sqrt{9}\sqrt{3}}{3} = \frac{15\sqrt{3} + 3\sqrt{3}}{3} = \frac{18\sqrt{3}}{3} = 6\sqrt{3}$$

PTS: 3 REF: 061236ia STA: A.N.3 TOP: Operations with Radicals

37 ANS:

Carol's, by 14.9. $V_M = 5 \times 3.5 \times 7 = 122.5$. $V_C = \pi \times 2.5^2 \times 7 \approx 137.4$. $137.4 - 122.5 = 14.9$

PTS: 4 REF: 061237ia STA: A.G.2 TOP: Volume

38 ANS:

4. $3(x + 1) - 5x = 12 - (6x - 7)$
 $3x + 3 - 5x = 12 - 6x + 7$
 $-2x + 3 = -6x + 19$
 $4x = 16$
 $x = 4$

PTS: 4 REF: 061238ia STA: A.A.22 TOP: Solving Equations

39 ANS:

$26 \times 25 \times 24 \times 23 = 358,800$. $10^6 = 1,000,000$. Use the numeric password since there are over 500,000 employees

PTS: 4

REF: 061239ia

STA: A.N.8

TOP: Permutations

0812ia
Answer Section

- 1 ANS: 3 PTS: 2 REF: 081201ia STA: A.G.7
TOP: Solving Linear Systems
- 2 ANS: 3
$$\frac{120}{60} = \frac{m}{150}$$
$$m = 300$$
- PTS: 2 REF: 081202ia STA: A.M.1 TOP: Using Rate
- 3 ANS: 3
$$0.06y + 200 = 0.03y + 350$$
$$0.03y = 150$$
$$y = 5,000$$
- PTS: 2 REF: 081203ia STA: A.A.25 TOP: Solving Equations with Decimals
- 4 ANS: 1 PTS: 2 REF: 081204ia STA: A.S.12
TOP: Scatter Plots
- 5 ANS: 2 PTS: 2 REF: 081205ia STA: A.A.13
TOP: Addition and Subtraction of Polynomials KEY: addition
- 6 ANS: 4
$$375 + 155w \geq 900$$
$$155w \geq 525$$
$$w \geq 3.4$$
- PTS: 2 REF: 081206ia STA: A.A.6 TOP: Modeling Inequalities
- 7 ANS: 3 PTS: 2 REF: 081207ia STA: A.A.19
TOP: Factoring the Difference of Perfect Squares
- 8 ANS: 3 PTS: 2 REF: 081208ia STA: A.S.17
TOP: Scatter Plots
- 9 ANS: 1 PTS: 2 REF: 081209ia STA: A.N.1
TOP: Properties of Reals
- 10 ANS: 4
$$8900 \text{ ft} \times \frac{1 \text{ mi}}{5280 \text{ ft}} \approx 1.7 \text{ mi}$$
- PTS: 2 REF: 081210ia STA: A.M.2 TOP: Conversions
KEY: dimensional analysis
- 11 ANS: 3 PTS: 2 REF: 081211ia STA: A.A.9
TOP: Exponential Functions
- 12 ANS: 2 PTS: 2 REF: 081212ia STA: A.A.5
TOP: Modeling Inequalities

- 13 ANS: 3
The other situations are qualitative.
- PTS: 2 REF: 081213ia STA: A.S.1 TOP: Analysis of Data
- 14 ANS: 4 PTS: 2 REF: 081214ia STA: A.G.10
TOP: Identifying the Vertex of a Quadratic Given Graph
- 15 ANS: 2 PTS: 2 REF: 081215ia STA: A.A.1
TOP: Expressions
- 16 ANS: 4
 $SA = 2lw + 2hw + 2lh = 2(3)(2.2) + 2(7.5)(2.2) + 2(3)(7.5) = 91.2$
- PTS: 2 REF: 081216ia STA: A.G.2 TOP: Surface Area
- 17 ANS: 4
 $2(2) - (-7) = 11$
- PTS: 2 REF: 081217ia STA: A.A.39 TOP: Identifying Points on a Line
- 18 ANS: 2 PTS: 2 REF: 081218ia STA: A.G.5
TOP: Graphing Quadratic Functions
- 19 ANS: 3
 $y = mx + b \quad y = \frac{3}{4}x - \frac{1}{2}$
 $1 = \left(\frac{3}{4}\right)(2) + b \quad 4y = 3x - 2$
 $1 = \frac{3}{2} + b$
 $b = -\frac{1}{2}$
- PTS: 2 REF: 081219ia STA: A.A.34 TOP: Writing Linear Equations
- 20 ANS: 1
 $\left| \frac{4(-6) + 18}{4!} \right| = \left| \frac{-6}{24} \right| = \frac{1}{4}$
- PTS: 2 REF: 081220ia STA: A.N.6 TOP: Evaluating Expressions
- 21 ANS: 3
 $A \cup C = \{1, 2, 3, 5, 7, 9\}$
- PTS: 2 REF: 081221ia STA: A.A.31 TOP: Set Theory
- 22 ANS: 4
 $\frac{2x^2(x^4 - 9x^2 + 1)}{2x^2}$
- PTS: 2 REF: 081222ia STA: A.A.16 TOP: Rational Expressions
KEY: $a > 0$
- 23 ANS: 2 PTS: 2 REF: 081223ia STA: A.A.32
TOP: Slope

24 ANS: 4

$$V = \pi r^2 h$$

$$32\pi = \pi r^2(2)$$

$$16 = r^2$$

$$4 = r$$

PTS: 2

REF: 081224ia

STA: A.G.2

TOP: Volume

25 ANS: 3

$$x^2 - 4 = 0$$

$$(x + 2)(x - 2) = 0$$

$$x = \pm 2$$

PTS: 2

REF: 081225ia

STA: A.A.15

TOP: Undefined Rationals

26 ANS: 3

$$\frac{2}{x+1} = \frac{x+1}{2}$$

$$x^2 + 2x + 1 = 4$$

$$x^2 + 2x - 3 = 0$$

$$(x + 3)(x - 1) = 3$$

$$x = -3, 1$$

PTS: 2

REF: 081226ia

STA: A.A.26

TOP: Solving Rationals

27 ANS: 2

$$W + L = 72$$

$$W - L = 12$$

$$2W = 84$$

$$W = 42$$

PTS: 2

REF: 081227ia

STA: A.A.7

TOP: Writing Linear Systems

28 ANS: 1

$$4 + 6 + 10 + \frac{6\pi}{2} = 20 + 3\pi$$

PTS: 2

REF: 081228ia

STA: A.G.1

TOP: Compositions of Polygons and Circles

KEY: perimeter

29 ANS: 4

PTS: 2

REF: 081229ia

STA: A.S.23

TOP: Theoretical Probability

KEY: independent events

30 ANS: 3

PTS: 2

REF: 081230ia

STA: A.A.23

TOP: Transforming Formulas

31 ANS:

$$6.56 \times 10^{-2}$$

PTS: 2

REF: 081231ia

STA: A.N.4

TOP: Operations with Scientific Notation

32 ANS:

$$\frac{x+2}{2} \times \frac{4(x+5)}{(x+4)(x+2)} = \frac{2(x+5)}{x+4}$$

PTS: 2

REF: 081232ia

STA: A.A.18

TOP: Multiplication and Division of Rationals

KEY: multiplication

33 ANS:

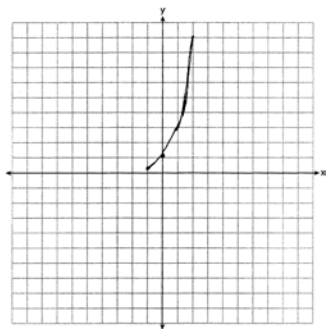

PTS: 2

REF: 081233ia

STA: A.G.4

TOP: Graphing Exponential Functions

34 ANS:

$$3, 0, 20. \quad 15 - 12 = 3. \quad 12 - 12 = 0$$

PTS: 3

REF: 081234ia

STA: A.S.9

TOP: Frequency Histograms, Bar Graphs and Tables

35 ANS:

$$\frac{(5.9 \times 10.3 \times 1.7) - (6 \times 10 \times 1.5)}{5.9 \times 10.3 \times 1.7} \approx 0.129$$

PTS: 3

REF: 081235ia

STA: A.M.3

TOP: Error

KEY: volume and surface area

36 ANS:

$$(-3, -5), (3, 7). \quad x^2 + 2x - 8 = 2x + 1. \quad y = 2(3) + 1 = 7$$

$$x^2 - 9 = 0 \quad y = 2(-3) + 1 = -5$$

$$x = \pm 3$$

PTS: 3

REF: 081236ia

STA: A.A.11

TOP: Quadratic-Linear Systems

37 ANS:

(C,B,T), (C,B,5), (C,N,T), (C,N,5), (C,2,T), (C,2,5), (F,B,T), (F,B,5), (F,N,T), (F,N,5), (F,2,T), (F,2,5). 1, 2.

PTS: 4

REF: 081237ia

STA: A.S.19

TOP: Sample Space

38 ANS:

$$54, 23. \cos A = \frac{17}{29}. \sqrt{29^2 - 17^2} \approx 23$$

$$x \approx 54$$

PTS: 4

REF: 081238ia

STA: A.A.43

TOP: Using Trigonometry to Find an Angle

39 ANS:

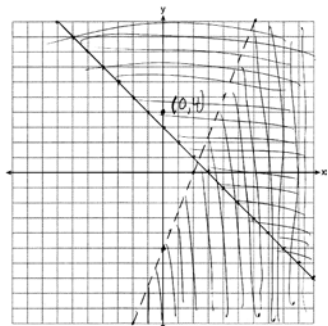

PTS: 4

REF: 081239ia

STA: A.G.7

TOP: Systems of Linear Inequalities

0113ia
Answer Section

1 ANS: 1 REF: 011301ia STA: A.S.12 TOP: Scatter Plots

2 ANS: 2

$$\frac{20}{3.98} = \frac{180}{x}$$

$$20x = 716.4$$

$$x = 35.82 \approx 36$$

REF: 011302ia STA: A.M.1 TOP: Using Rate

3 ANS: 1 REF: 011303ia STA: A.A.1 TOP: Expressions

4 ANS: 3 REF: 011304ia STA: A.G.7 TOP: Solving Linear Systems

5 ANS: 4

$$5 - 2x = -4x - 7$$

$$2x = -12$$

$$x = -6$$

REF: 011305ia STA: A.A.22 TOP: Solving Equations

6 ANS: 1 REF: 011306ia STA: A.A.19

TOP: Factoring the Difference of Perfect Squares

7 ANS: 2

$$\cos x = \frac{\text{adjacent}}{\text{hypotenuse}} = \frac{16}{20}$$

REF: 011307ia STA: A.A.42 TOP: Trigonometric Ratios

8 ANS: 4 REF: 011308ia STA: A.S.18 TOP: Conditional Probability

9 ANS: 3 REF: 011309ia STA: A.G.3 TOP: Defining Functions

10 ANS: 3 REF: 011310ia STA: A.A.9 TOP: Exponential Functions

11 ANS: 1 REF: 011311ia STA: A.A.2 TOP: Expressions

12 ANS: 3

$$\frac{10^3}{5^3} = \frac{1000}{125} = 8$$

REF: 011312ia STA: A.G.2 TOP: Volume

13 ANS: 2

To determine student opinion, survey the widest range of students.

REF: 011313ia STA: A.S.3 TOP: Analysis of Data

14 ANS: 3

$$x = \frac{-b}{2a} = \frac{-8}{2(1)} = -4. y = (-4)^2 + 8(-4) + 10 = -6. (-4, -6)$$

REF: 011314ia STA: A.A.41 TOP: Identifying the Vertex of a Quadratic Given Equation

15 ANS: 3 REF: 011315ia STA: A.G.1 TOP: Compositions of Polygons and Circles
KEY: area

16 ANS: 2 REF: 011316ia STA: A.A.14 TOP: Division of Polynomials

17 ANS: 3 REF: 011317ia STA: A.M.2 TOP: Conversions
KEY: dimensional analysis

18 ANS: 4 REF: 011318ia STA: A.A.29 TOP: Set Theory

19 ANS: 3 REF: 011319ia STA: A.N.4 TOP: Operations with Scientific Notation

20 ANS: 4

$$x^2 - 14x + 48 = 0$$

$$(x - 6)(x - 8) = 0$$

$$x = 6, 8$$

REF: 011320ia STA: A.A.28 TOP: Roots of Quadratics

21 ANS: 2

$$|-3 - 4| - (-3)^2 = 7 - 9 = -2$$

REF: 011321ia STA: A.N.6 TOP: Evaluating Expressions

22 ANS: 1

Using $m = -\frac{A}{B}$, the slope of $2x - 3y = 9$ is $\frac{2}{3}$.

REF: 011322ia STA: A.A.38 TOP: Parallel and Perpendicular Lines

23 ANS: 2

$$-1 \leq 3(2) + 1. \quad 2 - (-1) > 1$$

$$-1 \leq 7 \quad 3 > 1$$

REF: 011323ia STA: A.A.40 TOP: Systems of Linear Inequalities

24 ANS: 3 REF: 011324ia STA: A.A.36 TOP: Parallel and Perpendicular Lines

25 ANS: 4

$$P(\text{odd}) = \frac{7 + 14 + 20}{75} = \frac{41}{75}. \quad P(\text{even}) = \frac{22 + 6 + 6}{75} = \frac{34}{75}. \quad P(3 \text{ or less}) = \frac{14 + 22 + 7}{75} = \frac{43}{75}.$$

$$P(2 \text{ or } 4) = \frac{22 + 6}{75} = \frac{28}{75}$$

REF: 011325ia STA: A.S.22 TOP: Theoretical Probability

26 ANS: 2

$$A = \{4, 9, 16, 25, 36, 49, 64, 81, 100\}$$

REF: 011326ia STA: A.A.30 TOP: Set Theory

27 ANS: 1

$$\frac{2x^2 + 10x - 28}{4x + 28} = \frac{2(x^2 + 5x - 14)}{4x + 28} = \frac{2(x + 7)(x - 2)}{4(x + 7)} = \frac{x - 2}{2}$$

REF: 011327ia STA: A.A.16 TOP: Rational Expressions

KEY: $a > 0$

28 ANS: 1

$$\frac{1}{7} + \frac{2x}{3} = \frac{15x-3}{21}$$

$$\frac{14x+3}{21} = \frac{15x-3}{21}$$

$$14x+3 = 15x-3$$

$$x = 6$$

REF: 011328ia STA: A.A.25 TOP: Solving Equations with Fractional Expressions

29 ANS: 2

mean = 7, median = 6 and mode = 6

REF: 011329ia STA: A.S.4 TOP: Central Tendency

30 ANS: 2 REF: 011330ia STA: A.G.5 TOP: Graphing Quadratic Functions

31 ANS:

$$4\sqrt{75} = 4\sqrt{25}\sqrt{3} = 20\sqrt{3}$$

REF: 011331ia STA: A.N.2 TOP: Simplifying Radicals

32 ANS:

$$5x^3 - 20x^2 - 60x$$

$$5x(x^2 - 4x - 12)$$

$$5x(x+2)(x-6)$$

REF: 011332ia STA: A.A.20 TOP: Factoring Polynomials

33 ANS:

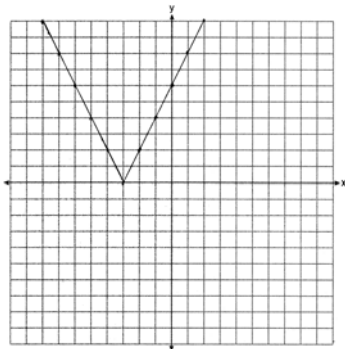

REF: 011333ia STA: A.G.4 TOP: Graphing Absolute Value Functions

34 ANS:

(1,A), (1,B), (1,C), (3,A), (3,B), (3,C), (5,A), (5,B), (5,C), (7,A), (7,B), (7,C), (9,A), (9,B), (9,C). 6

REF: 011334ia STA: A.S.19 TOP: Sample Space

35 ANS:

$$3n + 4p = 8.50 \quad 3(2.50) + 4p = 8.50$$

$$5n + 8p = 14.50 \quad 4p = 1$$

$$6n + 8p = 17 \quad p = 0.25$$

$$n = 2.50$$

REF: 011335ia STA: A.A.7 TOP: Writing Linear Systems

36 ANS:

$$\left| \frac{(24.2 \times 14.1) - (24 \times 14)}{(24.2 \times 14.1)} \right| = \frac{5.22}{341.22} \approx 0.015$$

REF: 011336ia STA: A.M.3 TOP: Error KEY: area

37 ANS:

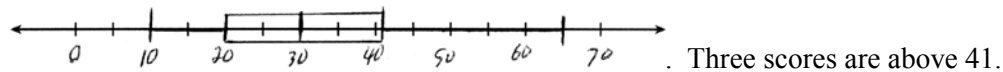

REF: 011337ia STA: A.S.5 TOP: Box-and-Whisker Plots

38 ANS:

$$\tan 48 = \frac{9}{x} \quad \sin 48 = \frac{9}{y}$$

$$x \approx 8 \quad y \approx 12$$

REF: 011338ia STA: A.A.44 TOP: Using Trigonometry to Find a Side

39 ANS:

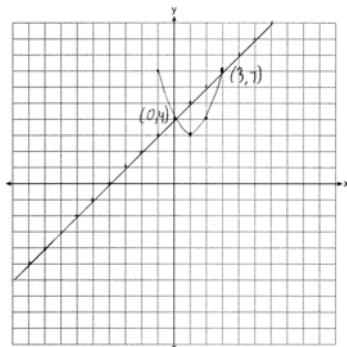

REF: 011339ia STA: A.G.9 TOP: Quadratic-Linear Systems

0613ia
Answer Section

- 1 ANS: 1 PTS: 2 REF: 061301ia STA: A.A.1
TOP: Expressions
- 2 ANS: 1
$$\frac{20 - 6}{(20 - 6) + 15 + 7 + 8} = \frac{14}{44}$$
- PTS: 2 REF: 061302ia STA: A.S.18 TOP: Conditional Probability
- 3 ANS: 3 PTS: 2 REF: 061303ia STA: A.S.17
TOP: Scatter Plots
- 4 ANS: 3
 $2(5) + k = 9$
 $10 + k = 9$
 $k = -1$
- PTS: 2 REF: 061304ia STA: A.A.39 TOP: Identifying Points on a Line
- 5 ANS: 4
 $5.5 \text{ g} \times \frac{4 \text{ q}}{1 \text{ g}} \times \frac{32 \text{ oz}}{1 \text{ q}} = 704 \text{ oz}$
- PTS: 2 REF: 061305ia STA: A.M.2 TOP: Conversions
KEY: dimensional analysis
- 6 ANS: 3 PTS: 2 REF: 061306ia STA: A.G.8
TOP: Solving Quadratics by Graphing
- 7 ANS: 1
$$\frac{(x + 5)(x + 3)}{x + 5} = x + 3$$
- PTS: 2 REF: 0613071a STA: A.A.16 TOP: Rational Expressions
KEY: $a > 0$
- 8 ANS: 1
The other situations are quantitative.
- PTS: 2 REF: 061308ia STA: A.S.1 TOP: Analysis of Data
- 9 ANS: 3
 $6! + \frac{5!(3!)}{4!} - 10 = 720 + 5(6) - 10 = 740$
- PTS: 2 REF: 061309ia STA: A.N.6 TOP: Evaluating Expressions
- 10 ANS: 1 PTS: 2 REF: 061310ia STA: A.A.29
TOP: Set Theory

11 ANS: 2

$$x^2 - 16x + 28 = 0$$

$$(x - 14)(x - 2) = 0$$

$$x = 14, 2$$

PTS: 2 REF: 061311ia STA: A.A.27 TOP: Solving Quadratics by Factoring

12 ANS: 2 PTS: 2 REF: 061312ia STA: A.A.12

TOP: Powers of Powers

13 ANS: 3

Due to lack of specificity in the wording, this 13th question was removed from the June, 2013 Regents Exam.

PTS: 2 REF: 061313ia STA: A.S.2 TOP: Analysis of Data

14 ANS: 2 PTS: 2 REF: 061314ia STA: A.S.6

TOP: Box-and-Whisker Plots

15 ANS: 1 PTS: 2 REF: 061315ia STA: A.A.15

TOP: Undefined Rationals

16 ANS: 1

$$rx - st = r$$

$$rx = r + st$$

$$x = \frac{r + st}{r}$$

PTS: 2 REF: 061316ia STA: A.A.23 TOP: Transforming Formulas

17 ANS: 2

$$\frac{x + 2}{2} = \frac{4}{x}$$

$$x^2 + 2x = 8$$

$$x^2 + 2x - 8 = 0$$

$$(x + 4)(x - 2) = 0$$

$$x = -4, 2$$

PTS: 2 REF: 061317ia STA: A.A.26 TOP: Solving Rationals

18 ANS: 3 PTS: 2 REF: 061318ia STA: A.G.4

TOP: Families of Functions

19 ANS: 4

$$m = \frac{-A}{B} = \frac{-4}{3}$$

PTS: 2 REF: 061319ia STA: A.A.37 TOP: Slope

20 ANS: 4 PTS: 2 REF: 061320ia STA: A.G.6

TOP: Linear Inequalities

21 ANS: 4 PTS: 2 REF: 061321ia STA: A.A.5

TOP: Modeling Inequalities

- 22 ANS: 1 PTS: 2 REF: 061322ia STA: A.A.13
TOP: Addition and Subtraction of Polynomials KEY: subtraction
- 23 ANS: 3 PTS: 2 REF: 061323ia STA: A.A.1
TOP: Expressions
- 24 ANS: 3 PTS: 2 REF: 061324ia STA: A.A.31
TOP: Set Theory
- 25 ANS: 4
$$\sin D = \frac{\text{opposite}}{\text{hypotenuse}} = \frac{12}{13}$$
- PTS: 2 REF: 061325ia STA: A.A.43 TOP: Using Trigonometry to Find an Angle
- 26 ANS: 2 PTS: 2 REF: 061326ia STA: A.A.28
TOP: Roots of Quadratics
- 27 ANS: 2 PTS: 2 REF: 061327ia STA: A.A.36
TOP: Parallel and Perpendicular Lines
- 28 ANS: 3
 ${}_{18}P_3 = 4896$
- PTS: 2 REF: 061328ia STA: A.N.8 TOP: Permutations
- 29 ANS: 3
$$\sqrt{8^2 - 6^2} = \sqrt{28} = \sqrt{4} \sqrt{7} = 2\sqrt{7}$$
- PTS: 2 REF: 061329ia STA: A.A.45 TOP: Pythagorean Theorem
- 30 ANS: 1
 $x^2 - 5x + 3 = x - 6$ $y = 3 - 6 = -3$ (3, -3)
 $x^2 - 6x + 9 = 0$
 $(x - 3)^2 = 0$
 $x = 3$
- PTS: 2 REF: 061330ia STA: A.G.9 TOP: Quadratic-Linear Systems
- 31 ANS:
 $-5(x - 7) < 15$
 $x - 7 > -3$
 $x > 4$
- PTS: 2 REF: 061331ia STA: A.A.24 TOP: Solving Inequalities
- 32 ANS:
 $V = \pi r^2 h = \pi \cdot 6.5^2 \cdot 24 = 1014\pi$
- PTS: 2 REF: 061332ia STA: A.G.2 TOP: Volume

33 ANS:

$$t = \frac{d}{s} = \frac{136,000,000}{31,000} \approx 4387.1 \text{ hours. } \frac{4387.1}{24} \approx 183$$

PTS: 2 REF: 061333ia STA: A.M.1 TOP: Speed

34 ANS:

$$5 \times 3 \times 5 \times 3 = 225. \quad 1 \times 3 \times 5 \times 3 = 45. \quad 1 \times 2 \times 5 \times 3 = 30$$

PTS: 4 REF: 061334ia STA: A.N.7 TOP: Multiplication Counting Principle

35 ANS:

$$\tan x = \frac{350}{1000}$$

$$x \approx 19$$

PTS: 3 REF: 061335ia STA: A.A.43 TOP: Using Trigonometry to Find an Angle

36 ANS:

$$5 - 2\sqrt{3} + \sqrt{9}\sqrt{3} + 2(3) = 5 - 2\sqrt{3} + 3\sqrt{3} + 6 = 11 + \sqrt{3}$$

PTS: 3 REF: 061336ia STA: A.N.3 TOP: Operations with Radicals

37 ANS:

$$\frac{2}{3x} + \frac{12}{3x} = \frac{7}{x+1}$$

$$\frac{14}{3x} = \frac{7}{x+1}$$

$$21x = 14x + 14$$

$$7x = 14$$

$$x = 2$$

PTS: 4 REF: 061337ia STA: A.A.26 TOP: Solving Rationals

38 ANS:

$$\frac{5}{8} \times \frac{3}{7} = \frac{15}{56}. \quad \frac{5}{8} \times \frac{4}{7} = \frac{20}{56}. \quad \frac{20}{56} + \frac{3}{8} \times \frac{2}{7} = \frac{26}{56}$$

PTS: 4 REF: 061338ia STA: A.S.23 TOP: Theoretical Probability

KEY: dependent events

39 ANS:

$$\text{Area of rectangle minus area of semicircle: } (5 + 6 + 5) \times 5 - \frac{\pi \times 3^2}{2} \approx 65.86$$

PTS: 4 REF: 061339ia STA: A.G.1 TOP: Compositions of Polygons and Circles
KEY: area

0813ia

Answer Section

- 1 ANS: 1 PTS: 2 REF: 081301ia STA: A.S.12
TOP: Scatter Plots
- 2 ANS: 1 PTS: 2 REF: 081302ia STA: A.A.13
TOP: Addition and Subtraction of Polynomials KEY: addition
- 3 ANS: 4 PTS: 2 REF: 081303ia STA: A.S.22
TOP: Theoretical Probability
- 4 ANS: 3
 $N = 5 + J$ $N(N - 5) = 84$
 $J = N - 5$ $N^2 - 5N - 84 = 0$
 $NJ = 84$ $(N - 12)(N + 7) = 0$
 $N = 12$
- PTS: 2 REF: 081304ia STA: A.A.8 TOP: Writing Quadratics
- 5 ANS: 2 PTS: 2 REF: 081305ia STA: A.A.1
TOP: Expressions
- 6 ANS: 4
 $A = \{1, 3, 5, 7, 9, 11, 13, 15, 17, 19\}$
- PTS: 2 REF: 081306ia STA: A.A.30 TOP: Set Theory
- 7 ANS: 1
 $m = -3$
- PTS: 2 REF: 081307ia STA: A.A.38 TOP: Parallel and Perpendicular Lines
- 8 ANS: 3 PTS: 2 REF: 081308ia STA: A.G.3
TOP: Defining Functions KEY: graphs
- 9 ANS: 1
 $-3x + 8 \geq 14$
 $-3x \geq 6$
 $x \leq -2$
- PTS: 2 REF: 081309ia STA: A.A.21 TOP: Interpreting Solutions
- 10 ANS: 2
 $m = \frac{-7 - 1}{4 - 9} = \frac{-8}{-5} = \frac{8}{5}$
- PTS: 2 REF: 081310ia STA: A.A.33 TOP: Slope
- 11 ANS: 2 PTS: 2 REF: 081311ia STA: A.A.12
TOP: Division of Powers
- 12 ANS: 4 PTS: 2 REF: 081312ia STA: A.S.6
TOP: Box-and-Whisker Plots

- 13 ANS: 3
The other situations are quantitative.
- PTS: 2 REF: 081313ia STA: A.S.1 TOP: Analysis of Data
- 14 ANS: 2 PTS: 2 REF: 081314ia STA: A.G.6
TOP: Linear Inequalities
- 15 ANS: 1 PTS: 2 REF: 081315ia STA: A.A.10
TOP: Solving Linear Systems
- 16 ANS: 4
 $x^2 - 2x - 15 = 0$
 $(x + 3)(x - 5) = 0$
 $x = -3, 5$
- PTS: 2 REF: 081316ia STA: A.A.15 TOP: Undefined Rationals
- 17 ANS: 3 PTS: 2 REF: 081317ia STA: A.A.21
TOP: Interpreting Solutions
- 18 ANS: 2 PTS: 2 REF: 081318ia STA: A.A.12
TOP: Powers of Powers
- 19 ANS: 1 PTS: 2 REF: 081319ia STA: A.N.1
TOP: Identifying Properties
- 20 ANS: 4
 $3 + 2 - 1 = 4$
- PTS: 2 REF: 081320ia STA: A.A.6 TOP: Venn Diagrams
- 21 ANS: 4 PTS: 2 REF: 081321ia STA: A.A.29
TOP: Set Theory
- 22 ANS: 4 PTS: 2 REF: 081322ia STA: A.G.10
TOP: Identifying the Vertex of a Quadratic Given Graph
- 23 ANS: 3
 $\sqrt{13^2 - 7^2} = \sqrt{120}$
- PTS: 2 REF: 081323ia STA: A.A.45 TOP: Pythagorean Theorem
- 24 ANS: 3
 $(2, T), (4, T), (6, T)$
- PTS: 2 REF: 081324ia STA: A.S.19 TOP: Sample Space
- 25 ANS: 2
 $s^3 = 8. 6 \times (2 \times 2) = 24$
 $s = 2$
- PTS: 2 REF: 081325ia STA: A.G.2 TOP: Surface Area

- 26 ANS: 1
 $4(5 + 5) + 10\pi = 40 + 10\pi$
- PTS: 2 REF: 081326ia STA: A.G.1 TOP: Compositions of Polygons and Circles
 KEY: perimeter
- 27 ANS: 2 PTS: 2 REF: 081327ia STA: A.S.16
 TOP: Central Tendency
- 28 ANS: 3
 $\frac{4}{3a} - \frac{5}{2a} = \frac{8}{6a} - \frac{15}{6a} = -\frac{7}{6a}$
- PTS: 2 REF: 081328ia STA: A.A.17 TOP: Addition and Subtraction of Rationals
- 29 ANS: 1
 $\cos A = \frac{\text{adjacent}}{\text{hypotenuse}} = \frac{3}{5}$
- PTS: 2 REF: 081329ia STA: A.A.42 TOP: Trigonometric Ratios
- 30 ANS: 2
 $2y + 2w = x$
 $2w = x - 2y$
 $w = \frac{x - 2y}{2}$
- PTS: 2 REF: 081330ia STA: A.A.23 TOP: Transforming Formulas
- 31 ANS:
 $\frac{5.4 \text{ miles}}{\text{hour}} \times \frac{5280 \text{ feet}}{\text{mile}} \times \frac{1 \text{ hour}}{60 \text{ min}} = \frac{475.2 \text{ ft}}{\text{min}}$
- PTS: 2 REF: 081331ia STA: A.M.2 TOP: Conversions
 KEY: dimensional analysis
- 32 ANS:
 $2\sqrt{108} = 2\sqrt{36} \sqrt{3} = 12\sqrt{3}$
- PTS: 2 REF: 081332ia STA: A.N.2 TOP: Simplifying Radicals
- 33 ANS:
 $A = P(1 + R)^t = 2000(1 + 0.035)^4 \approx 2295$
- PTS: 2 REF: 081333ia STA: A.A.9 TOP: Exponential Functions
- 34 ANS:
 $800 - (895)(0.75)(1.08) = 75.05$
- PTS: 3 REF: 081334ia STA: A.N.5 TOP: Percents

35 ANS:

$$L - S = 28 \quad . \quad 2S - 8 = S + 28$$

$$L = 2S - 8 \quad S = 36$$

$$L = S + 28 \quad L = 36 + 28 = 64$$

PTS: 3

REF: 081335ia

STA: A.A.7

TOP: Writing Linear Systems

36 ANS:

$$\frac{(10.75)(12.5) - (10.5)(12.25)}{(10.75)(12.5)} \approx 0.043$$

PTS: 3

REF: 081336ia

STA: A.M.3

TOP: Error

KEY: area

37 ANS:

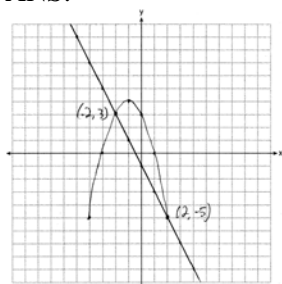

PTS: 4

REF: 081337ia

STA: A.G.9

TOP: Quadratic-Linear Systems

38 ANS:

$$\frac{3x(x+3)}{(x+3)(x+2)} \times \frac{(x-3)(x+2)}{(x+3)(x-3)} = \frac{3x}{x+3}$$

PTS: 4

REF: 081338ia

STA: A.A.18

TOP: Multiplication and Division of Rationals

KEY: division

39 ANS:

$$\frac{12}{20} \times \frac{8}{19} + \frac{8}{20} \times \frac{12}{19} = \frac{192}{380} \cdot 1 - P(BB) = 1 - \left(\frac{8}{20} \times \frac{7}{19} \right) = \frac{380}{380} - \frac{56}{380} = \frac{324}{380}$$

PTS: 4

REF: 081339ia

STA: A.S.23

TOP: Theoretical Probability

KEY: dependent events

0114ia
Answer Section

- 1 ANS: 4 REF: 011401ia STA: A.A.3 TOP: Expressions
- 2 ANS: 3
 $3mn(m + 4n)$
- REF: 011402ia STA: A.A.20 TOP: Factoring Polynomials
- 3 ANS: 1 REF: 011403ia STA: A.A.5 TOP: Modeling Inequalities
- 4 ANS: 3 REF: 011404ia STA: A.S.3 TOP: Analysis of Data
- 5 ANS: 4
 An element of the domain, 1, is paired with two different elements of the range, 1 and -1 .
- REF: 011405ia STA: A.G.3 TOP: Defining Functions
 KEY: ordered pairs
- 6 ANS: 1
 $y = mx + b$
 $-8 = (3)(-2) + b$
 $b = -2$
- REF: 011406ia STA: A.A.34 TOP: Writing Linear Equations
- 7 ANS: 2
 $6^2 - \frac{(3)^2\pi}{2}$
- REF: 011407ia STA: A.G.1 TOP: Compositions of Polygons and Circles
 KEY: area
- 8 ANS: 3 REF: 011408ia STA: A.S.6 TOP: Box-and-Whisker Plots
- 9 ANS: 2
 $y = \frac{1}{2}x - 2$
- REF: 011409ia STA: A.A.37 TOP: Slope
- 10 ANS: 2
 $2x + 3y = 7$
 $3x + 3y = 9$
 $x = 2$
- REF: 011410ia STA: A.A.10 TOP: Solving Linear Systems
- 11 ANS: 2 REF: 011411ia STA: A.S.17 TOP: Scatter Plots
- 12 ANS: 4 REF: 011412ia STA: A.A.14 TOP: Division of Polynomials
- 13 ANS: 3 REF: 011413ia STA: A.A.4 TOP: Modeling Equations

14 ANS: 3

The other situations are qualitative.

REF: 011414ia STA: A.S.1 TOP: Analysis of Data

15 ANS: 2 REF: 011415ia STA: A.S.21 TOP: Experimental Probability

16 ANS: 1

$$x = \frac{-b}{2a} = \frac{-6}{2(3)} = -1. \quad y = 3(-1)^2 + 6(-1) + 1 = -2$$

REF: 011416ia STA: A.A.41 TOP: Identifying the Vertex of a Quadratic Given Equation

17 ANS: 2

$$\sqrt{48^2 + 40^2} = \sqrt{2304 + 1600} = \sqrt{3904} \approx 62$$

REF: 011417ia STA: A.A.45 TOP: Pythagorean Theorem

18 ANS: 1 REF: 011418ia STA: A.A.24 TOP: Solving Inequalities

19 ANS: 2

$$d = st = 45 \times 3 = 135 \text{ miles. } t = \frac{d}{s} = \frac{135}{55} \approx 2.5 \text{ hours}$$

REF: 011419ia STA: A.M.1 TOP: Speed

20 ANS: 3

$$\frac{2n}{5} + \frac{3n}{2} = \frac{4n + 15n}{10} = \frac{19n}{10}$$

REF: 011420ia STA: A.A.17 TOP: Addition and Subtraction of Rationals

21 ANS: 3

$$2(4)^0 + (4)! = 2 + 24 = 26$$

REF: 011421ia STA: A.N.6 TOP: Evaluating Expressions

22 ANS: 3

$$y > 2x - 3$$

REF: 011422ia STA: A.G.6 TOP: Linear Inequalities

23 ANS: 4 REF: 011423ia STA: A.G.4 TOP: Graphing Exponential Functions

24 ANS: 3

$$\frac{x^2 - 25}{x^2 - x - 20} = \frac{(x+5)(x-5)}{(x+4)(x-5)} = \frac{x+5}{x+4}$$

REF: 011424ia STA: A.A.16 TOP: Rational Expressions

KEY: $a > 0$

25 ANS: 1
 $abx - 5 = 0$

$$abx = 5$$

$$x = \frac{5}{ab}$$

REF: 011425ia STA: A.A.23 TOP: Transforming Formulas

26 ANS: 4 REF: 011426ia STA: A.A.30 TOP: Set Theory

27 ANS: 4
 $2x^2 - 8x = 0$

$$2x(x - 4) = 0$$

$$x = 0, 4$$

REF: 011427ia STA: A.A.28 TOP: Roots of Quadratics

28 ANS: 3 REF: 011428ia STA: A.N.1 TOP: Properties of Reals

29 ANS: 4 REF: 011429ia STA: A.A.13 TOP: Addition and Subtraction of Polynomials

KEY: subtraction

30 ANS: 4
 $x + x + 2 + x + 4 = 3x + 6$

REF: 011430ia STA: A.A.1 TOP: Expressions

31 ANS:

$$\frac{\sqrt{84}}{2\sqrt{3}} = \frac{\sqrt{4}\sqrt{21}}{2\sqrt{3}} = \sqrt{\frac{21}{3}} = \sqrt{7}$$

REF: 011431ia STA: A.N.3 TOP: Operations with Radicals

KEY: division

32 ANS:
 If there are 31 students, the 16th student's time represents the median. The 16th time is in the 41-80 interval on the cumulative frequency table and the 71-80 interval on the related frequency table.

REF: 011432ia STA: A.S.9 TOP: Frequency Histograms, Bar Graphs and Tables

33 ANS:
 $1000(1.03)^5 \approx 1159.27$

REF: 011433ia STA: A.A.9 TOP: Exponential Functions

34 ANS:

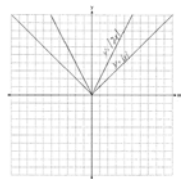

. Graph becomes narrower as the coefficient increases.

REF: 011434ia STA: A.G.5 TOP: Graphing Absolute Value Functions

35 ANS:

$$\frac{6(5.2)^2 - 6(5)^2}{6(5.2)^2} \approx .075$$

REF: 011435ia STA: A.M.3 TOP: Error KEY: volume and surface area

36 ANS:

$$\tan 38 = \frac{opp}{80}$$

$$opp = 80 \tan 38 \approx 62.5$$

REF: 011436ia STA: A.A.44 TOP: Using Trigonometry to Find a Side

37 ANS:

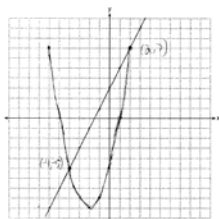

REF: 011437ia STA: A.G.9 TOP: Quadratic-Linear Systems

38 ANS:

$$\frac{3}{x+5} = \frac{2x}{x^2-8}$$

$$3x^2 - 24 = 2x^2 + 10x$$

$$x^2 - 10x + 24 = 0$$

$$(x-12)(x+2) = 0$$

$$x = 12, -2$$

REF: 011438ia STA: A.A.26 TOP: Solving Rationals

39 ANS:

cap-jacket: TT, TR, TW, BB, BR, BW, RB, RR, RW, GB, GR, GW, 10, 6.

REF: 011439ia STA: A.S.19 TOP: Sample Space