

JMAP REGENTS AT RANDOM

The NY Integrated Algebra Regents Exams
Fall 2007-January 2014

www.jmap.org

Integrated Algebra Regents at Random

- 1 On the set of axes below, graph the equation $y = x^2 + 2x - 8$. Using the graph, determine and state the roots of the equation $x^2 + 2x - 8 = 0$.

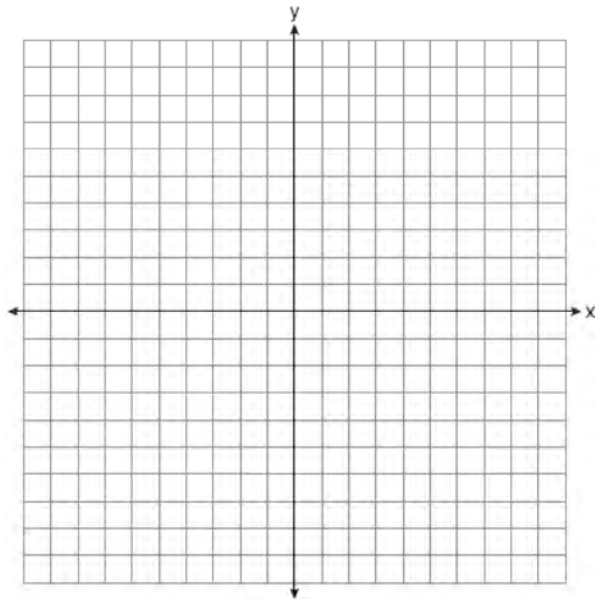

- 2 The line represented by the equation $2y - 3x = 4$ has a slope of
- 1) $-\frac{3}{2}$
 - 2) 2
 - 3) 3
 - 4) $\frac{3}{2}$
- 3 If the expression $(2y^a)^4$ is equivalent to $16y^8$, what is the value of a ?
- 1) 12
 - 2) 2
 - 3) 32
 - 4) 4

- 4 Campsite A and campsite B are located directly opposite each other on the shores of Lake Omega, as shown in the diagram below. The two campsites form a right triangle with Sam's position, S . The distance from campsite B to Sam's position is 1,300 yards, and campsite A is 1,700 yards from his position.

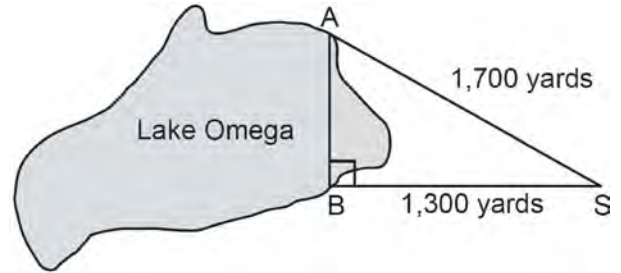

- What is the distance from campsite A to campsite B , to the nearest yard?
- 1) 1,095
 - 2) 1,096
 - 3) 2,140
 - 4) 2,141
- 5 Brianna's score on a national math assessment exceeded the scores of 95,000 of the 125,000 students who took the assessment. What was her percentile rank?
- 1) 6
 - 2) 24
 - 3) 31
 - 4) 76
- 6 Factor completely: $5x^3 - 20x^2 - 60x$

- 7 What is $24x^2y^6 - 16x^6y^2 + 4xy^2$ divided by $4xy^2$?
- 1) $6xy^4 - 4x^5$
 - 2) $6xy^4 - 4x^5 + 1$
 - 3) $6x^2y^3 - 4x^6y$
 - 4) $6x^2y^3 - 4x^6y + 1$

- 8 Written in set-builder notation, $S = \{1, 3, 5, 7, 9\}$ is
- 1) $\{x | 1 < x < 9, \text{ where } x \text{ is a prime number}\}$
 - 2) $\{x | 1 \leq x \leq 9, \text{ where } x \text{ is a prime number}\}$
 - 3) $\{x | 1 < x < 9, \text{ where } x \text{ is an odd integer}\}$
 - 4) $\{x | 1 \leq x \leq 9, \text{ where } x \text{ is an odd integer}\}$

- 9 Timmy bought a skateboard and two helmets for a total of d dollars. If each helmet cost h dollars, the cost of the skateboard could be represented by
- 1) $2dh$
 - 2) $\frac{dh}{2}$
 - 3) $d - 2h$
 - 4) $d - \frac{h}{2}$

- 10 For which values of x is the fraction $\frac{x^2 + x - 6}{x^2 + 5x - 6}$ undefined?
- 1) 1 and -6
 - 2) 2 and -3
 - 3) 3 and -2
 - 4) 6 and -1

- 11 What are the coordinates of the vertex and the equation of the axis of symmetry of the parabola shown in the graph below?

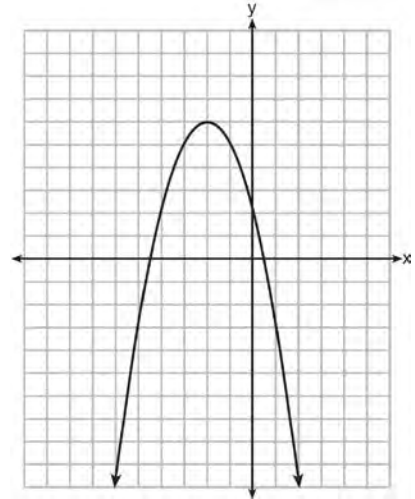

- 1) $(0, 2)$ and $y = 2$
 - 2) $(0, 2)$ and $x = 2$
 - 3) $(-2, 6)$ and $y = -2$
 - 4) $(-2, 6)$ and $x = -2$
- 12 Which expression represents $\frac{x^2 - 3x - 10}{x^2 - 25}$ in simplest form?
- 1) $\frac{2}{5}$
 - 2) $\frac{x+2}{x+5}$
 - 3) $\frac{x-2}{x-5}$
 - 4) $\frac{-3x-10}{-25}$

13 Which equation is an example of the use of the associative property of addition?

- 1) $x + 7 = 7 + x$
- 2) $3(x + y) = 3x + 3y$
- 3) $(x + y) + 3 = x + (y + 3)$
- 4) $3 + (x + y) = (x + y) + 3$

14 Factored completely, the expression

$3x^3 - 33x^2 + 90x$ is equivalent to

- 1) $3x(x^2 - 33x + 90)$
- 2) $3x(x^2 - 11x + 30)$
- 3) $3x(x + 5)(x + 6)$
- 4) $3x(x - 5)(x - 6)$

15 How many cubes with 5-inch sides will completely fill a cube that is 10 inches on a side?

- 1) 50
- 2) 25
- 3) 8
- 4) 4

16 The equation of the axis of symmetry of the graph of $y = 2x^2 - 3x + 7$ is

- 1) $x = \frac{3}{4}$
- 2) $y = \frac{3}{4}$
- 3) $x = \frac{3}{2}$
- 4) $y = \frac{3}{2}$

17 Given: $A = \{2, 4, 5, 7, 8\}$

$$B = \{3, 5, 8, 9\}$$

What is $A \cup B$?

- 1) $\{5\}$
- 2) $\{5, 8\}$
- 3) $\{2, 3, 4, 7, 9\}$
- 4) $\{2, 3, 4, 5, 7, 8, 9\}$

18 Which expression represents the number of hours in w weeks and d days?

- 1) $7w + 12d$
- 2) $84w + 24d$
- 3) $168w + 24d$
- 4) $168w + 60d$

19 When $8x^2 + 3x + 2$ is subtracted from $9x^2 - 3x - 4$, the result is

- 1) $x^2 - 2$
- 2) $17x^2 - 2$
- 3) $-x^2 + 6x + 6$
- 4) $x^2 - 6x - 6$

20 What is the slope of the line that passes through the points $(4, -7)$ and $(9, 1)$?

- 1) $\frac{5}{8}$
- 2) $\frac{8}{5}$
- 3) $-\frac{6}{12}$
- 4) $-\frac{13}{6}$

- 21 The length of one side of a square is 13 feet. What is the length, to the *nearest foot*, of a diagonal of the square?
- 1) 13
 - 2) 18
 - 3) 19
 - 4) 26

- 22 The roots of a quadratic equation can be found using the graph below.

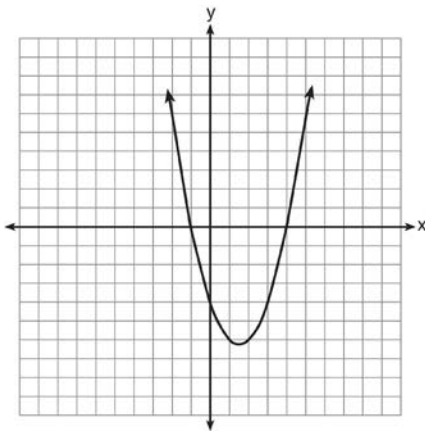

What are the roots of this equation?

- 1) -4, only
 - 2) -4 and -1
 - 3) -1 and 4
 - 4) -4, -1, and 4
- 23 The volume of a cylindrical can is 32π cubic inches. If the height of the can is 2 inches, what is its radius, in inches?
- 1) 8
 - 2) 2
 - 3) 16
 - 4) 4

- 24 Solve the inequality $-5(x - 7) < 15$ algebraically for x .

- 25 What is the solution of $\frac{2}{x+1} = \frac{x+1}{2}$?
- 1) -1 and -3
 - 2) -1 and 3
 - 3) 1 and -3
 - 4) 1 and 3

- 26 Express $\frac{3\sqrt{75} + \sqrt{27}}{3}$ in simplest radical form.

- 27 Based on the line of best fit drawn below, which value could be expected for the data in June 2015?

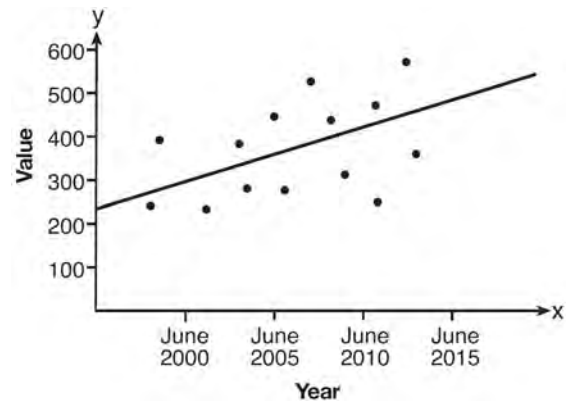

- 1) 230
- 2) 310
- 3) 480
- 4) 540

Integrated Algebra Regents Exam Questions at Random
www.jmap.org

- 28 Which equation represents a line that is parallel to the line whose equation is $y = -3x - 7$?
- 1) $y = -3x + 4$
 - 2) $y = -\frac{1}{3}x - 7$
 - 3) $y = \frac{1}{3}x + 5$
 - 4) $y = 3x - 2$
- 29 A correct translation of “six less than twice the value of x ” is
- 1) $2x < 6$
 - 2) $2x - 6$
 - 3) $6 < 2x$
 - 4) $6 - 2x$
- 30 There are 18 students in a class. Each day, the teacher randomly selects three students to assist in a game: a leader, a recorder, and a timekeeper. In how many possible ways can the jobs be assigned?
- 1) 306
 - 2) 816
 - 3) 4896
 - 4) 5832
- 31 What is the product of $(3x + 2)$ and $(x - 7)$?
- 1) $3x^2 - 14$
 - 2) $3x^2 - 5x - 14$
 - 3) $3x^2 - 19x - 14$
 - 4) $3x^2 - 23x - 14$
- 32 Solve algebraically for x :
 $3(x + 1) - 5x = 12 - (6x - 7)$
- 33 The length of a rectangle is 15 and its width is w . The perimeter of the rectangle is, *at most*, 50. Which inequality can be used to find the longest possible width?
- 1) $30 + 2w < 50$
 - 2) $30 + 2w \leq 50$
 - 3) $30 + 2w > 50$
 - 4) $30 + 2w \geq 50$
- 34 Using the substitution method, Ken solves the following system of equations algebraically.
- $$2x - y = 5$$
- $$3x + 2y = -3$$
- Which equivalent equation could Ken use?
- 1) $3x + 2(2x - 5) = -3$
 - 2) $3x + 2(5 - 2x) = -3$
 - 3) $3\left(y + \frac{5}{2}\right) + 2y = -3$
 - 4) $3\left(\frac{5}{2} - y\right) + 2y = -3$
- 35 Given: $A = \{1, 3, 5, 7, 9\}$
 $B = \{2, 4, 6, 8, 10\}$
 $C = \{2, 3, 5, 7\}$
 $D = \{1, 2, 3, 4, 5, 6, 7, 8, 9, 10\}$
- What statement is *false*?
- 1) $A \cup B \cup C = D$
 - 2) $A \cap B \cap C = \{ \}$
 - 3) $A \cup C = \{1, 2, 3, 5, 7\}$
 - 4) $A \cap C = \{3, 5, 7\}$

- 36 What is $2\sqrt{45}$ expressed in simplest radical form?
- 1) $3\sqrt{5}$
 - 2) $5\sqrt{5}$
 - 3) $6\sqrt{5}$
 - 4) $18\sqrt{5}$
- 37 The distance from Earth to Mars is 136,000,000 miles. A spaceship travels at 31,000 miles per hour. Determine, to the *nearest day*, how long it will take the spaceship to reach Mars.
- 38 Mr. Taylor raised all his students' scores on a recent test by five points. How were the mean and the range of the scores affected?
- 1) The mean increased by five and the range increased by five.
 - 2) The mean increased by five and the range remained the same.
 - 3) The mean remained the same and the range increased by five.
 - 4) The mean remained the same and the range remained the same.
- 39 Is the equation $A = 21000(1 - 0.12)^t$ a model of exponential growth or exponential decay, and what is the rate (percent) of change per time period?
- 1) exponential growth and 12%
 - 2) exponential growth and 88%
 - 3) exponential decay and 12%
 - 4) exponential decay and 88%
- 40 A bag contains five green gumdrops and six red gumdrops. If Kim pulls a green gumdrop out of the bag and eats it, what is the probability that the next gumdrop she pulls out will be red?
- 1) $\frac{5}{11}$
 - 2) $\frac{5}{10}$
 - 3) $\frac{6}{11}$
 - 4) $\frac{6}{10}$
- 41 The value of y in the equation $0.06y + 200 = 0.03y + 350$ is
- 1) 500
 - 2) 1,666. $\overline{6}$
 - 3) 5,000
 - 4) 18,333. $\overline{3}$
- 42 Which statement is true about the data set 4, 5, 6, 6, 7, 9, 12?
- 1) mean = mode
 - 2) mode = median
 - 3) mean < median
 - 4) mode > mean
- 43 Which equation represents the line that passes through the point (3, 4) and is parallel to the x -axis?
- 1) $x = 4$
 - 2) $x = -3$
 - 3) $y = 4$
 - 4) $y = -3$

- 44 The roots of the equation $x^2 - 14x + 48 = 0$ are
- 1) -6 and -8
 - 2) -6 and 8
 - 3) 6 and -8
 - 4) 6 and 8

- 45 Which equation is represented by the graph below?

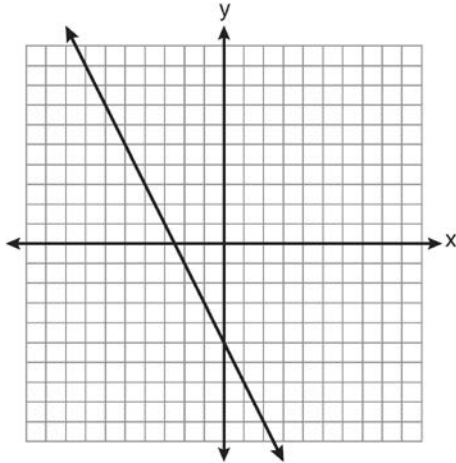

- 1) $2y + x = 10$
 - 2) $y - 2x = -5$
 - 3) $-2y = 10x - 4$
 - 4) $2y = -4x - 10$
- 46 The current population of a town is 10,000. If the population, P , increases by 20% each year, which equation could be used to find the population after t years?
- 1) $P = 10,000(0.2)^t$
 - 2) $P = 10,000(0.8)^t$
 - 3) $P = 10,000(1.2)^t$
 - 4) $P = 10,000(1.8)^t$

- 47 A man standing on level ground is 1000 feet away from the base of a 350-foot-tall building. Find, to the *nearest degree*, the measure of the angle of elevation to the top of the building from the point on the ground where the man is standing.

- 48 The quotient of $\frac{8x^5 - 2x^4 + 4x^3 - 6x^2}{2x^2}$ is
- 1) $16x^7 - 4x^6 + 8x^5 - 12x^4$
 - 2) $4x^7 - x^6 + 2x^5 - 3x^4$
 - 3) $4x^3 - x^2 + 2x - 3x$
 - 4) $4x^3 - x^2 + 2x - 3$

- 49 A metal pipe is used to hold up a 9-foot fence, as shown in the diagram below. The pipe makes an angle of 48° with the ground.

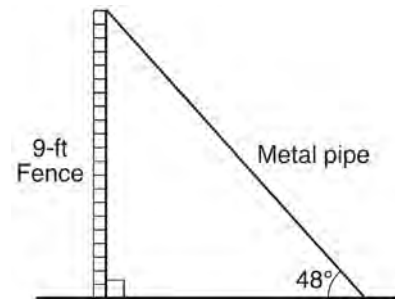

Determine, to the *nearest foot*, how far the bottom of the pipe is from the base of the fence. Determine, to the *nearest foot*, the length of the metal pipe.

- 50 In the figure below, $ABCD$ is a square and semicircle O has a radius of 6.

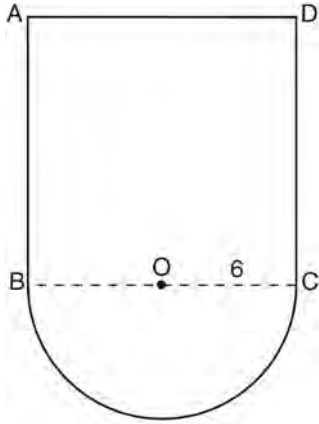

What is the area of the figure?

- 1) $36 + 6\pi$
 - 2) $36 + 18\pi$
 - 3) $144 + 18\pi$
 - 4) $144 + 36\pi$
- 51 Solve the following system of equations algebraically for y :
- $$2x + 2y = 9$$
- $$2x - y = 3$$
- 52 The sum of $3x^2 + 5x - 6$ and $-x^2 + 3x + 9$ is
- 1) $2x^2 + 8x - 15$
 - 2) $2x^2 + 8x + 3$
 - 3) $2x^4 + 8x^2 + 3$
 - 4) $4x^2 + 2x - 15$
- 53 Gabriella has 20 quarters, 15 dimes, 7 nickels, and 8 pennies in a jar. After taking 6 quarters out of the jar, what will be the probability of Gabriella randomly selecting a quarter from the coins left in the jar?
- 1) $\frac{14}{44}$
 - 2) $\frac{30}{44}$
 - 3) $\frac{14}{50}$
 - 4) $\frac{20}{50}$
- 54 Which value of x is the solution of the equation $\frac{1}{7} + \frac{2x}{3} = \frac{15x-3}{21}$?
- 1) 6
 - 2) 0
 - 3) $\frac{4}{13}$
 - 4) $\frac{6}{29}$
- 55 Shana wants to buy a new bicycle that has a retail price of \$259.99. She knows that it will be on sale next week for 30% off the retail price. If the tax rate is 7%, find the total amount, to the *nearest cent*, that she will save by waiting until next week.
- 56 Which set of data describes a situation that could be classified as qualitative?
- 1) the colors of the birds at the city zoo
 - 2) the shoe size of the zookeepers at the city zoo
 - 3) the heights of the giraffes at the city zoo
 - 4) the weights of the monkeys at the city zoo

- 57 Which situation is an example of bivariate data?
- 1) the number of pizzas Tanya eats during her years in high school
 - 2) the number of times Ezra puts air in his bicycle tires during the summer
 - 3) the number of home runs Elias hits per game and the number of hours he practices baseball
 - 4) the number of hours Nellie studies for her mathematics tests during the first half of the school year

- 58 The expression $100n^2 - 1$ is equivalent to
- 1) $(10n + 1)(10n - 1)$
 - 2) $(10n - 1)(10n - 1)$
 - 3) $(50n + 1)(50n - 1)$
 - 4) $(50n - 1)(50n - 1)$

- 59 Students calculated the area of a playing field to be 8,100 square feet. The actual area of the field is 7,678.5 square feet. Find the relative error in the area, to the nearest thousandth.

- 60 In a baseball game, the ball traveled 350.7 feet in 4.2 seconds. What was the average speed of the ball, in feet per second?
- 1) 83.5
 - 2) 177.5
 - 3) 354.9
 - 4) 1,472.9

- 61 The roots of the equation $3x^2 - 27x = 0$ are
- 1) 0 and 9
 - 2) 0 and -9
 - 3) 0 and 3
 - 4) 0 and -3

- 62 Which point lies on the graph represented by the equation $3y + 2x = 8$?
- 1) $(-2, 7)$
 - 2) $(0, 4)$
 - 3) $(2, 4)$
 - 4) $(7, -2)$
- 63 Peter walked 8,900 feet from home to school.

1 mile = 5,280 feet

How far, to the nearest tenth of a mile, did he walk?

- 1) 0.5
 - 2) 0.6
 - 3) 1.6
 - 4) 1.7
- 64 Craig sees an advertisement for a car in a newspaper. Which information would *not* be classified as quantitative?
- 1) the cost of the car
 - 2) the car's mileage
 - 3) the model of the car
 - 4) the weight of the car
- 65 Given: $R = \{1, 2, 3, 4\}$
 $A = \{0, 2, 4, 6\}$
 $P = \{1, 3, 5, 7\}$
- What is $R \cap P$?
- 1) $\{0, 1, 2, 3, 4, 5, 6, 7\}$
 - 2) $\{1, 2, 3, 4, 5, 7\}$
 - 3) $\{1, 3\}$
 - 4) $\{2, 4\}$

- 66 In a given linear equation, the value of the independent variable decreases at a constant rate while the value of the dependent variable increases at a constant rate. The slope of this line is
- 1) positive
 - 2) negative
 - 3) zero
 - 4) undefined

- 67 The vertex of the parabola $y = x^2 + 8x + 10$ lies in Quadrant
- 1) I
 - 2) II
 - 3) III
 - 4) IV

- 68 If the volume of a cube is 8 cubic centimeters, what is its surface area, in square centimeters?
- 1) 32
 - 2) 24
 - 3) 12
 - 4) 4

- 69 If the roots of a quadratic equation are -2 and 3 , the equation can be written as
- 1) $(x - 2)(x + 3) = 0$
 - 2) $(x + 2)(x - 3) = 0$
 - 3) $(x + 2)(x + 3) = 0$
 - 4) $(x - 2)(x - 3) = 0$

- 70 If $x = -3$, what is the value of $|x - 4| - x^2$?
- 1) -8
 - 2) -2
 - 3) 7
 - 4) 16

- 71 Which graph does *not* represent the graph of a function?

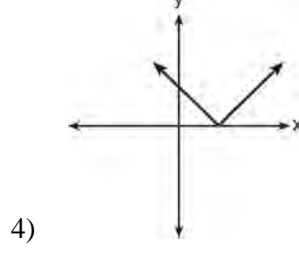
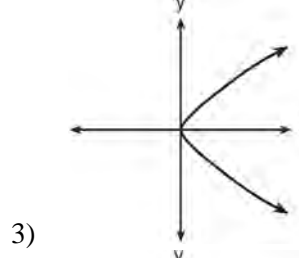
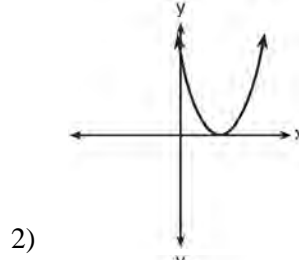
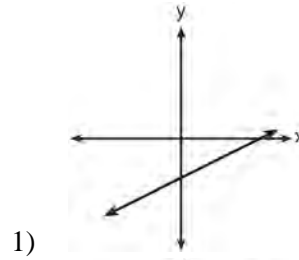

- 72 A car depreciates (loses value) at a rate of 4.5% annually. Greg purchased a car for \$12,500. Which equation can be used to determine the value of the car, V , after 5 years?
- 1) $V = 12,500(0.55)^5$
 - 2) $V = 12,500(0.955)^5$
 - 3) $V = 12,500(1.045)^5$
 - 4) $V = 12,500(1.45)^5$

- 73 Which event is certain to happen?
- 1) Everyone walking into a room will have red hair.
 - 2) All babies born in June will be males.
 - 3) The Yankees baseball team will win the World Series.
 - 4) The Sun will rise in the east.

- 74 Which expression is equivalent to

$$\frac{2x^6 - 18x^4 + 2x^2}{2x^2}?$$

- 1) $x^3 - 9x^2$
 - 2) $x^4 - 9x^2$
 - 3) $x^3 - 9x^2 + 1$
 - 4) $x^4 - 9x^2 + 1$
- 75 The total score in a football game was 72 points. The winning team scored 12 points more than the losing team. How many points did the winning team score?
- 1) 30
 - 2) 42
 - 3) 54
 - 4) 60
- 76 Which verbal expression is represented by $2(x + 4)$?
- 1) twice the sum of a number and four
 - 2) the sum of two times a number and four
 - 3) two times the difference of a number and four
 - 4) twice the product of a number and four
- 77 Express the product of $\frac{x+2}{2}$ and $\frac{4x+20}{x^2+6x+8}$ in simplest form.

- 78 Elizabeth is baking chocolate chip cookies. A single batch uses $\frac{3}{4}$ teaspoon of vanilla. If Elizabeth is mixing the ingredients for five batches at the same time, how many tablespoons of vanilla will she use?

$3 \text{ teaspoons} = 1 \text{ tablespoon}$
--

- 1) $1\frac{1}{4}$
 - 2) $1\frac{3}{4}$
 - 3) $3\frac{3}{4}$
 - 4) $5\frac{3}{4}$
- 79 A car uses one gallon of gasoline for every 20 miles it travels. If a gallon of gasoline costs \$3.98, how much will the gas cost, to the *nearest dollar*, to travel 180 miles?
- 1) 9
 - 2) 36
 - 3) 45
 - 4) 80

- 80 What is the value of $\left| \frac{4(-6) + 18}{4!} \right|$?

- 1) $\frac{1}{4}$
- 2) $-\frac{1}{4}$
- 3) 12
- 4) -12

- 81 In a game, a player must spin each spinner shown in the diagram below once.

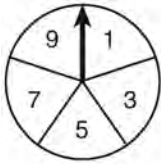

Spinner 1

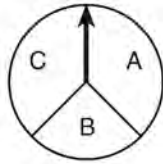

Spinner 2

Draw a tree diagram or list a sample space showing all possible outcomes. Determine the number of outcomes that consist of a prime number and a letter in the word "CAT."

- 82 Casey purchased a pack of assorted flower seeds and planted them in her garden. When the first 25 flowers bloomed, 11 were white, 5 were red, 3 were blue, and the rest were yellow. Find the empirical probability that a flower that blooms will be yellow.

- 83 The product of $\frac{4x^2}{7y^2}$ and $\frac{21y^3}{20x^4}$, expressed in

simplest form, is

- 1) $0.6x^2y$
- 2) $\frac{3y}{5x^2}$
- 3) $\frac{12x^2y^3}{20x^4y^2}$
- 4) $\frac{84x^2y^3}{140x^4y^2}$

- 84 Which graph does *not* represent a function?

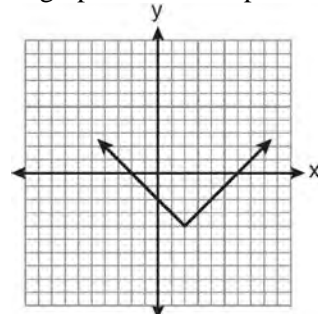

1)

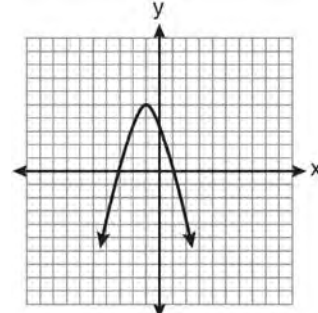

2)

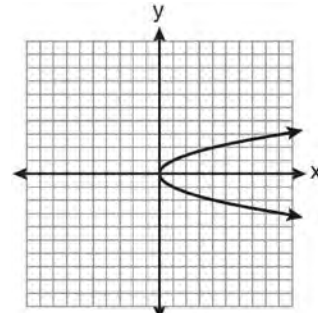

3)

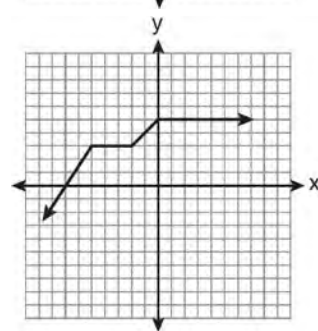

4)

- 85 On the set of axes below, graph $y = 2|x + 3|$.
 Include the interval $-7 \leq x \leq 1$.

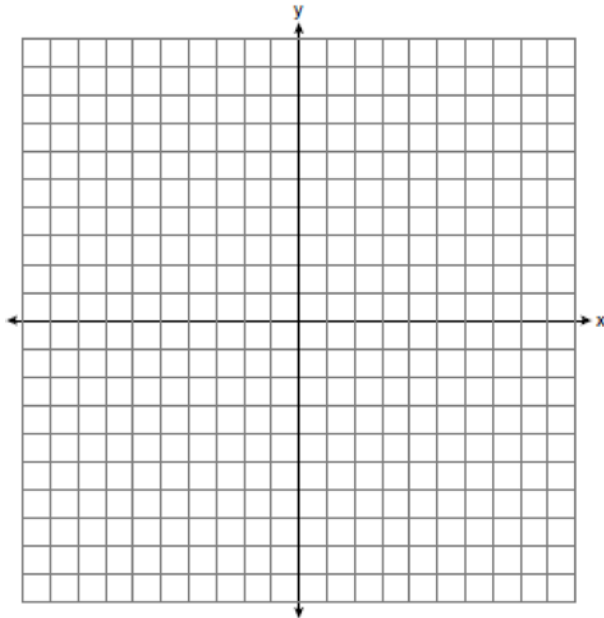

- 86 What is the slope of the line represented by the equation $4x + 3y = 12$?

- 1) $\frac{4}{3}$
- 2) $\frac{3}{4}$
- 3) $-\frac{3}{4}$
- 4) $-\frac{4}{3}$

- 87 The statement $|-15| < x < |-20|$ is true when x is equal to

- 1) -16
- 2) -14
- 3) 17
- 4) 21

- 88 What is the vertex of the parabola represented by the equation $y = -2x^2 + 24x - 100$?

- 1) $x = -6$
- 2) $x = 6$
- 3) $(6, -28)$
- 4) $(-6, -316)$

- 89 Jason's part-time job pays him \$155 a week. If he has already saved \$375, what is the minimum number of weeks he needs to work in order to have enough money to buy a dirt bike for \$900?

- 1) 8
- 2) 9
- 3) 3
- 4) 4

- 90 A soda container holds $5\frac{1}{2}$ gallons of soda. How many ounces of soda does this container hold?

1 quart = 32 ounces
 1 gallon = 4 quarts

- 1) 44
- 2) 176
- 3) 640
- 4) 704

- 91 A bottle contains 12 red marbles and 8 blue marbles. A marble is chosen at random and not replaced. Then, a second marble is chosen at random. Determine the probability that the two marbles are *not* the same color. Determine the probability that *at least* one of the marbles is red.

92 Which graph represents a function?

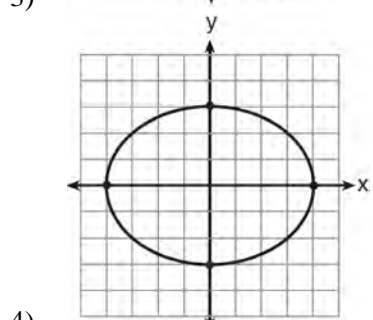
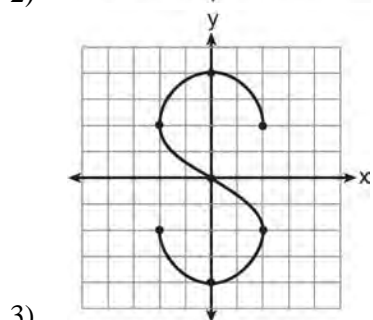
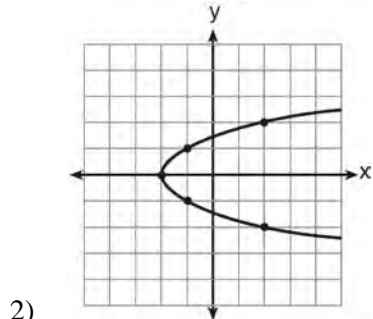
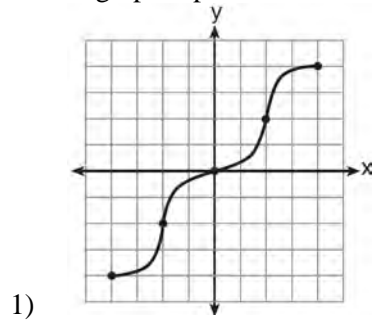

93 A system of equations is graphed on the set of axes below.

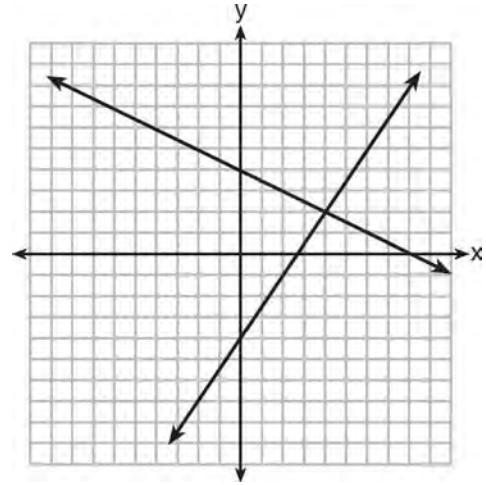

The solution of this system is

- 1) (0,4)
- 2) (2,4)
- 3) (4,2)
- 4) (8,0)

94 Which situation describes a negative correlation?

- 1) the amount of gas left in a car's tank and the amount of gas used from it
- 2) the number of gallons of gas purchased and the amount paid for the gas
- 3) the size of a car's gas tank and the number of gallons it holds
- 4) the number of miles driven and the amount of gas used

- 95 Which equation could be used to find the measure of angle D in the right triangle shown in the diagram below?

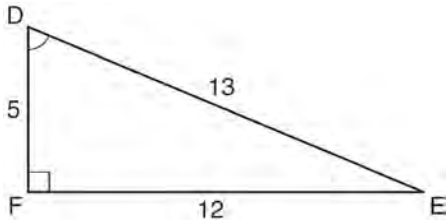

- 1) $\cos D = \frac{12}{13}$
 - 2) $\cos D = \frac{13}{12}$
 - 3) $\sin D = \frac{5}{13}$
 - 4) $\sin D = \frac{12}{13}$
- 96 If n is an odd integer, which equation can be used to find three consecutive odd integers whose sum is -3 ?
- 1) $n + (n + 1) + (n + 3) = -3$
 - 2) $n + (n + 1) + (n + 2) = -3$
 - 3) $n + (n + 2) + (n + 4) = -3$
 - 4) $n + (n + 2) + (n + 3) = -3$

- 97 A company is running a contest and offering a first, second, and third prize. First prize is a choice of a car or \$15,000 cash. Second prize is a choice of a motorbike, a trip to New York City, or \$2,000 cash. Third prize is a choice of a television or \$500 cash. If each prize is equally likely to be selected, list the sample space or draw a tree diagram of *all* possible different outcomes of first, second, and third prizes. Determine the number of ways that *all* three prizes selected could be cash. Determine the number of ways that *none* of the three prizes selected could be cash.

- 98 The inequality $-2 \leq x \leq 3$ can be written as
- 1) $(-2, 3)$
 - 2) $[-2, 3)$
 - 3) $(-2, 3]$
 - 4) $[-2, 3]$

- 99 If $2y + 2w = x$, then w , in terms of x and y , is equal to
- 1) $x - y$
 - 2) $\frac{x - 2y}{2}$
 - 3) $x + y$
 - 4) $\frac{x + 2y}{2}$

- 100 The diagram below shows the graph of which inequality?

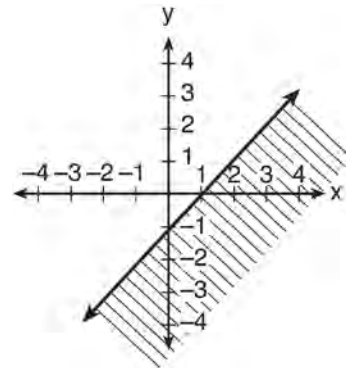

- 1) $y > x - 1$
- 2) $y \geq x - 1$
- 3) $y < x - 1$
- 4) $y \leq x - 1$

101 Which graph represents the inequality $y > 3$?

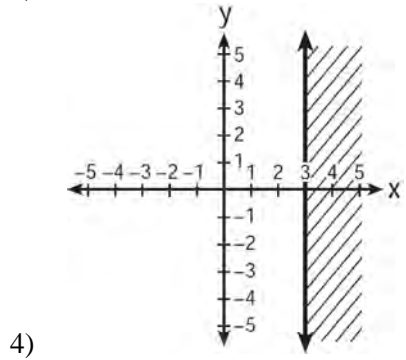
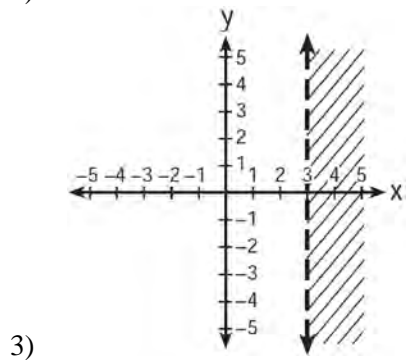
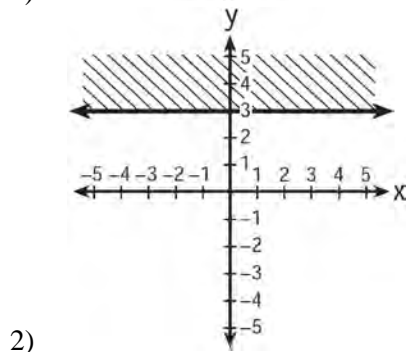
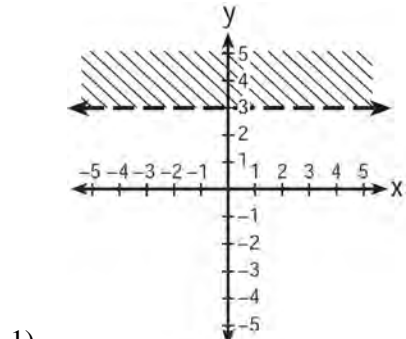

102 The box-and-whisker plot below represents the results of tests scores in a math class.

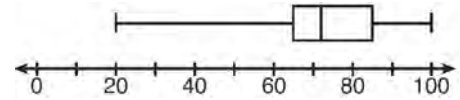

What do the scores 65, 85, and 100 represent?

- 1) Q_1 , median, Q_3
- 2) Q_1 , Q_3 , maximum
- 3) median, Q_1 , maximum
- 4) minimum, median, maximum

103 Given:

$A = \{\text{all odd integers from 1 through 19, inclusive}\}$

$B = \{9, 11, 13, 15, 17\}$

What is the complement of set B within set A ?

- 1) $\{3, 5, 7\}$
- 2) $\{3, 5, 7, 19\}$
- 3) $\{1, 3, 5, 7\}$
- 4) $\{1, 3, 5, 7, 19\}$

104 Mr. Smith invested \$2,500 in a savings account that earns 3% interest compounded annually. He made no additional deposits or withdrawals.

Which expression can be used to determine the number of dollars in this account at the end of 4 years?

- 1) $2500(1 + 0.03)^4$
- 2) $2500(1 + 0.3)^4$
- 3) $2500(1 + 0.04)^3$
- 4) $2500(1 + 0.4)^3$

- 105 If $A = \{0, 1, 3, 4, 6, 7\}$, $B = \{0, 2, 3, 5, 6\}$, and $C = \{0, 1, 4, 6, 7\}$, then $A \cap B \cap C$ is
- 1) $\{0, 1, 2, 3, 4, 5, 6, 7\}$
 - 2) $\{0, 3, 6\}$
 - 3) $\{0, 6\}$
 - 4) $\{0\}$

- 106 On the set of axes below, graph the following system of equations.

$$y + 2x = x^2 + 4$$

$$y - x = 4$$

Using the graph, determine and state the coordinates of *all* points in the solution set for the system of equations.

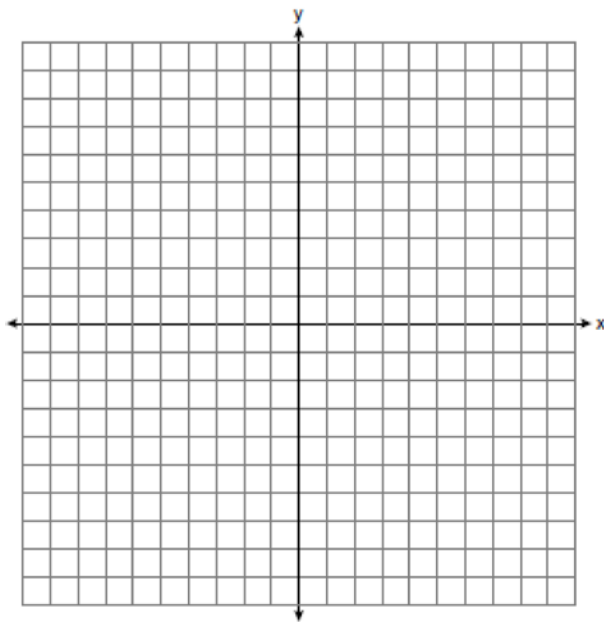

- 107 Janis measures the dimensions of the floor in her rectangular classroom for a rug. Her measurements are 10.50 feet by 12.25 feet. The actual measurements of the floor are 10.75 feet by 12.50 feet. Determine the relative error in calculating the area, to the *nearest thousandth*.

- 108 In right triangle ABC shown below, what is the value of $\cos A$?

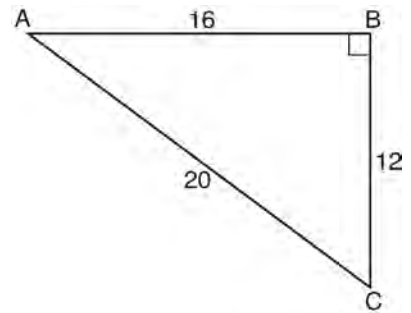

- 1) $\frac{12}{20}$
 - 2) $\frac{16}{20}$
 - 3) $\frac{20}{12}$
 - 4) $\frac{20}{16}$
- 109 Which equation represents a line that is parallel to the line whose equation is $2x - 3y = 9$?
- 1) $y = \frac{2}{3}x - 4$
 - 2) $y = -\frac{2}{3}x + 4$
 - 3) $y = \frac{3}{2}x - 4$
 - 4) $y = -\frac{3}{2}x + 4$

- 110 Mr. Stanton asked his students to write an algebraic expression on a piece of paper. He chose four students to go to the board and write their expression.

Robert wrote: $4(2x + 5) \geq 17$

Meredith wrote: $3y - 7 + 11z$

Steven wrote: $9w + 2 = 20$

Cynthia wrote: $8 + 10 - 4 = 14$

Which student wrote an algebraic expression?

- 1) Robert
 - 2) Meredith
 - 3) Steven
 - 4) Cynthia
- 111 If $rx - st = r$, which expression represents x ?
- 1) $\frac{r + st}{r}$
 - 2) $\frac{r}{r + st}$
 - 3) $\frac{r}{r - st}$
 - 4) $\frac{r - st}{r}$
- 112 If $k = am + 3mx$, the value of m in terms of a , k , and x can be expressed as

- 1) $\frac{k}{a + 3x}$
- 2) $\frac{k - 3mx}{a}$
- 3) $\frac{k - am}{3x}$
- 4) $\frac{k - a}{3x}$

- 113 Marcy determined that her father's age is four less than three times her age. If x represents Marcy's age, which expression represents her father's age?

- 1) $3x - 4$
- 2) $3(x - 4)$
- 3) $4x - 3$
- 4) $4 - 3x$

- 114 If $s = \frac{2x + t}{r}$, then x equals

- 1) $\frac{rs - t}{2}$
- 2) $\frac{rs + 1}{2}$
- 3) $2rs - t$
- 4) $rs - 2t$

- 115 A cell phone can receive 120 messages per minute. At this rate, how many messages can the phone receive in 150 seconds?

- 1) 48
- 2) 75
- 3) 300
- 4) 18,000

- 116 What is the sum of $-3x^2 - 7x + 9$ and $-5x^2 + 6x - 4$?

- 1) $-8x^2 - x + 5$
- 2) $-8x^4 - x + 5$
- 3) $-8x^2 - 13x + 13$
- 4) $-8x^4 - 13x^2 + 13$

- 117 A survey is being conducted to determine if a cable company should add another sports channel to their schedule. Which random survey would be the least biased?
- 1) surveying 30 men at a gym
 - 2) surveying 45 people at a mall
 - 3) surveying 50 fans at a football game
 - 4) surveying 20 members of a high school soccer team

- 118 A value of x that makes the expression

$$\frac{x^2 + 4x - 12}{x^2 - 2x - 15} \text{ undefined is}$$

- 1) -6
 - 2) -2
 - 3) 3
 - 4) 5
- 119 The scatter plot below shows the profit, by month, for a new company for the first year of operation. Kate drew a line of best fit, as shown in the diagram.

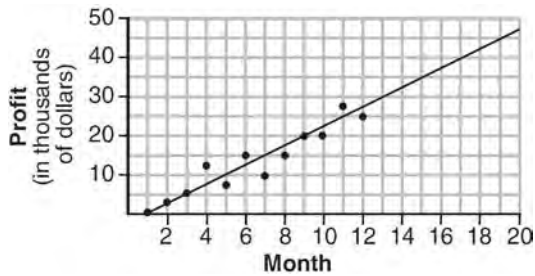

Using this line, what is the best estimate for profit in the 18th month?

- 1) \$35,000
- 2) \$37,750
- 3) \$42,500
- 4) \$45,000

- 120 Which equation is true?

- 1) $\frac{c^5}{d^7} \div \frac{d^3}{c} = \frac{c^4}{d^4}$
- 2) $(-2m^2p)^3 = -8m^6p^3$
- 3) $\left(\frac{s^3t^8}{s^4t^5}\right)^2 = \frac{t^5}{s^2}$
- 4) $(-2a^2b^3)(3ab^2) = a^3b^5$

- 121 Which ordered pair is in the solution set of the system of inequalities $y \leq 3x + 1$ and $x - y > 1$?

- 1) $(-1, -2)$
- 2) $(2, -1)$
- 3) $(1, 2)$
- 4) $(-1, 2)$

- 122 Byron is 3 years older than Doug. The product of their ages is 40. How old is Doug?

- 1) 10
- 2) 8
- 3) 5
- 4) 4

- 123 If the area of a rectangle is represented by $x^2 + 8x + 15$ and its length is represented by $x + 5$, which expression represents the width of the rectangle?

- 1) $x + 3$
- 2) $x - 3$
- 3) $x^2 + 6x + 5$
- 4) $x^2 + 7x + 10$

- 124 Oatmeal is packaged in a cylindrical container, as shown in the diagram below.

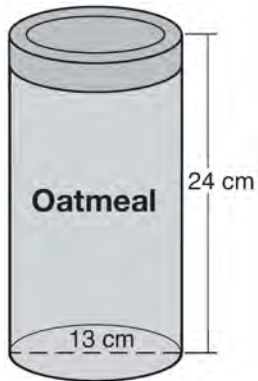

The diameter of the container is 13 centimeters and its height is 24 centimeters. Determine, in terms of π , the volume of the cylinder, in cubic centimeters.

- 125 What is the perimeter of the figure shown below, which consists of an isosceles trapezoid and a semicircle?

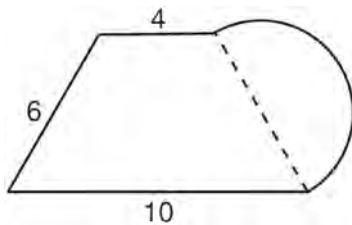

- 1) $20 + 3\pi$
 - 2) $20 + 6\pi$
 - 3) $26 + 3\pi$
 - 4) $26 + 6\pi$
- 126 Solve algebraically: $\frac{2}{3x} + \frac{4}{x} = \frac{7}{x+1}$
 [Only an algebraic solution can receive full credit.]

- 127 A set of data is graphed on the scatter plot below.

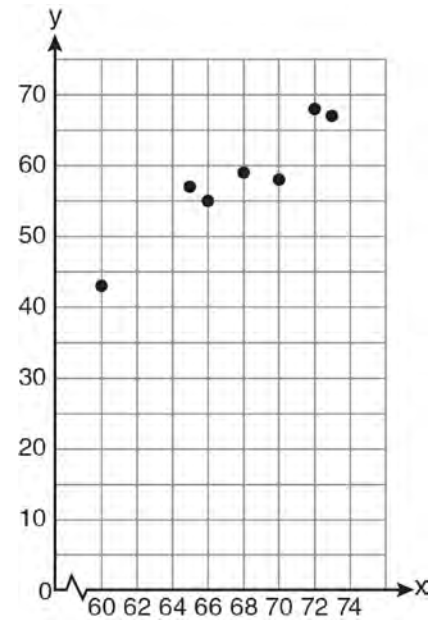

This scatter plot shows

- 1) no correlation
 - 2) positive correlation
 - 3) negative correlation
 - 4) undefined correlation
- 128 Express $\frac{3x^2 + 9x}{x^2 + 5x + 6} \div \frac{x^2 - 9}{x^2 - x - 6}$ in simplest form.

- 129 The expression $\frac{(4x^3)^2}{2x}$ is equivalent to
- 1) $4x^4$
 - 2) $4x^5$
 - 3) $8x^4$
 - 4) $8x^5$

- 130 Solve the following system of equations algebraically for *all* values of x and y .

$$y = x^2 + 2x - 8$$

$$y = 2x + 1$$

- 131 A turtle and a rabbit are in a race to see who is first to reach a point 100 feet away. The turtle travels at a constant speed of 20 feet per minute for the entire 100 feet. The rabbit travels at a constant speed of 40 feet per minute for the first 50 feet, stops for 3 minutes, and then continues at a constant speed of 40 feet per minute for the last 50 feet. Determine which animal won the race and by how much time.

- 132 The expression $\frac{x-3}{x+2}$ is undefined when the value of x is

- 1) -2, only
- 2) -2 and 3
- 3) 3, only
- 4) -3 and 2

- 133 If Angelina's weekly allowance is d dollars, which expression represents her allowance, in dollars, for x weeks?

- 1) dx
- 2) $7dx$
- 3) $x + 7d$
- 4) $\frac{d}{x}$

- 134 The expression $\frac{14+x}{x^2-4}$ is undefined when x is

- 1) -14, only
- 2) 2, only
- 3) -2 or 2
- 4) -14, -2, or 2

- 135 Which fraction is equivalent to $\frac{4}{3a} - \frac{5}{2a}$?

- 1) $-\frac{1}{a}$
- 2) $-\frac{1}{5a}$
- 3) $-\frac{7}{6a}$
- 4) $-\frac{7}{6a^2}$

- 136 What is one-third of 3^6 ?

- 1) 1^2
- 2) 3^2
- 3) 3^5
- 4) 9^6

- 137 In the diagram below of rectangle $AFEB$ and a semicircle with diameter CD , $AB = 5$ inches, $AB = BC = DE = FE$, and $CD = 6$ inches. Find the area of the shaded region, to the nearest hundredth of a square inch.

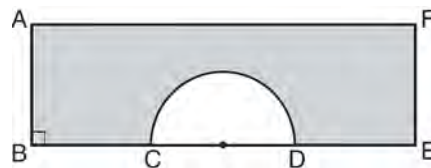

138 What is the slope of the line that passes through the points $(2, -3)$ and $(5, 1)$?

- 1) $-\frac{2}{3}$
- 2) $\frac{2}{3}$
- 3) $-\frac{4}{3}$
- 4) $\frac{4}{3}$

139 The bull's-eye of a dartboard has a radius of 2 inches and the entire board has a radius of 9 inches, as shown in the diagram below.

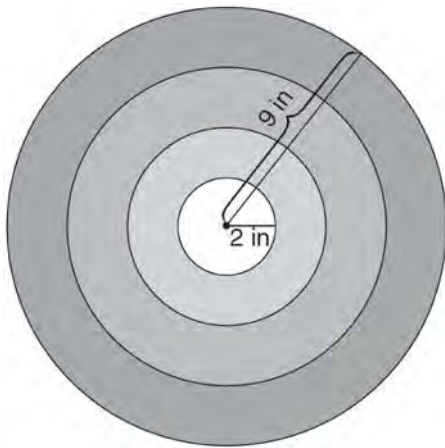

If a dart is thrown and hits the board, what is the probability that the dart will land in the bull's-eye?

- 1) $\frac{2}{9}$
- 2) $\frac{7}{9}$
- 3) $\frac{4}{81}$
- 4) $\frac{49}{81}$

140 The solutions of $x^2 = 16x - 28$ are

- 1) -2 and -14
- 2) 2 and 14
- 3) -4 and -7
- 4) 4 and 7

141 Ashley measured the dimensions of a rectangular prism to be 6 cm by 10 cm by 1.5 cm. The actual dimensions are 5.9 cm by 10.3 cm by 1.7 cm. Determine the relative error, to the nearest thousandth, in calculating the volume of the prism.

142 On the set of axes below, graph the following system of inequalities.

$$y + x \geq 3$$

$$5x - 2y > 10$$

State the coordinates of *one* point that satisfies $y + x \geq 3$, but does *not* satisfy $5x - 2y > 10$.

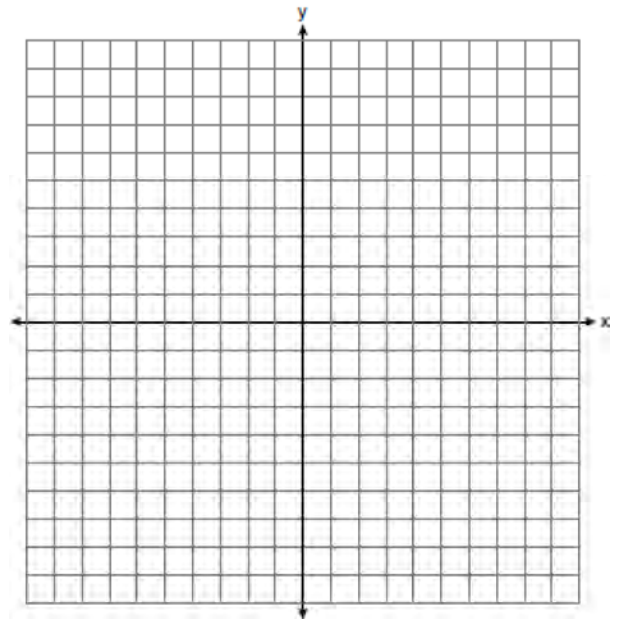

143 The formula for the volume of a pyramid is $V = \frac{1}{3} Bh$. What is h expressed in terms of B and V ?

- 1) $h = \frac{1}{3} VB$
- 2) $h = \frac{V}{3B}$
- 3) $h = \frac{3V}{B}$
- 4) $h = 3VB$

144 The rectangular prism shown below has a length of 3.0 cm, a width of 2.2 cm, and a height of 7.5 cm.

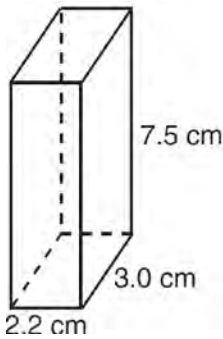

What is the surface area, in square centimeters?

- 1) 45.6
- 2) 49.5
- 3) 78.0
- 4) 91.2

145 A 28-foot ladder is leaning against a house. The bottom of the ladder is 6 feet from the base of the house. Find the measure of the angle formed by the ladder and the ground, to the nearest degree.

146 Two equations were graphed on the set of axes below.

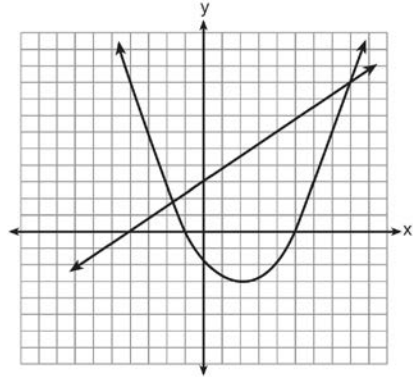

Which point is a solution of the system of equations shown on the graph?

- 1) (8, 9)
- 2) (5, 0)
- 3) (0, 3)
- 4) (2, -3)

147 The length and width of the base of a rectangular prism are 5.5 cm and 3 cm. The height of the prism is 6.75 cm. Find the exact value of the surface area of the prism, in square centimeters.

148 How is the graph of $y = x^2 + 4x + 3$ affected when the coefficient of x^2 is changed to a smaller positive number?

- 1) The graph becomes wider, and the y-intercept changes.
- 2) The graph becomes wider, and the y-intercept stays the same.
- 3) The graph becomes narrower, and the y-intercept changes.
- 4) The graph becomes narrower, and the y-intercept stays the same.

149 Which type of function is graphed below?

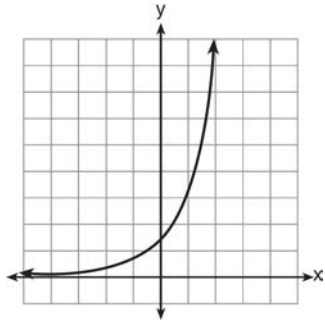

- 1) linear
- 2) quadratic
- 3) exponential
- 4) absolute value

150 The scatter plot shown below represents a relationship between x and y .

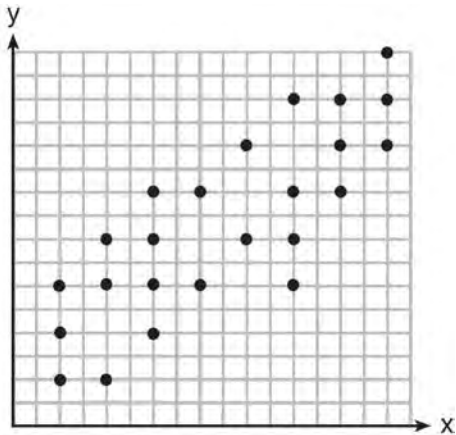

This type of relationship is

- 1) a positive correlation
- 2) a negative correlation
- 3) a zero correlation
- 4) not able to be determined

151 The box-and-whisker plot below represents a set of grades in a college statistics class.

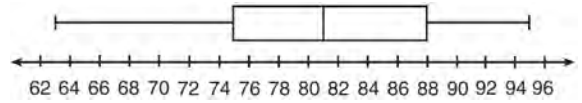

Which interval contains exactly 50% of the grades?

- 1) 63-88
- 2) 63-95
- 3) 75-81
- 4) 75-88

152 The number of hours spent on math homework during one week and the math exam grades for eleven students in Ms. Smith's algebra class are plotted below.

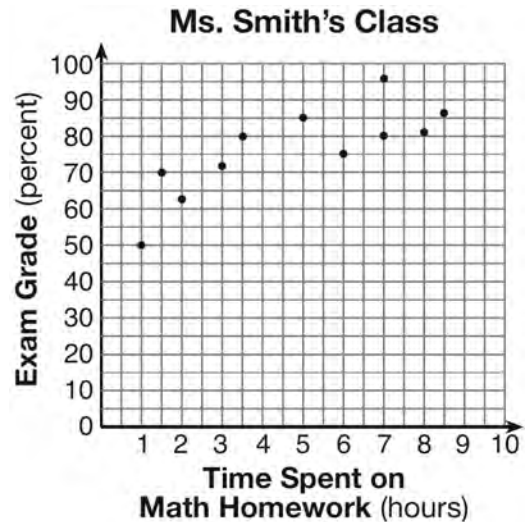

Based on the plotted data, what is the correlation between the time spent on homework and the exam grade?

- 1) positive
- 2) negative
- 3) no correlation
- 4) cannot be determined

153 Which graph represents a function?

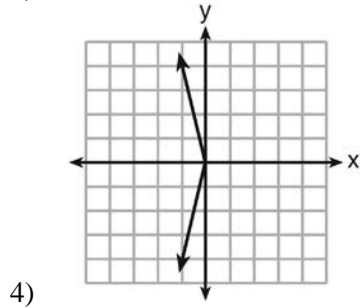
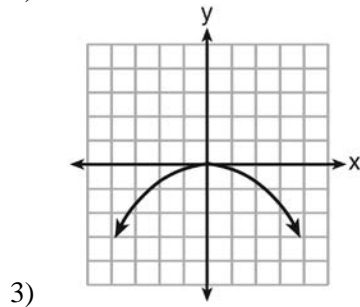
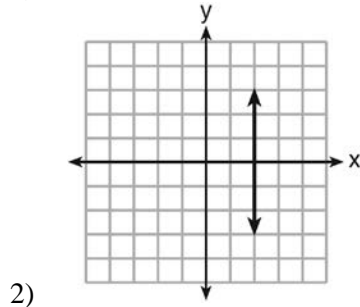
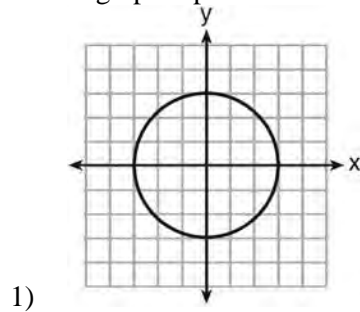

154 Express $2\sqrt{108}$ in simplest radical form.

155 In triangle RST , angle R is a right angle. If $TR = 6$ and $TS = 8$, what is the length of RS ?

- 1) 10
- 2) 2
- 3) $2\sqrt{7}$
- 4) $7\sqrt{2}$

156 In $\triangle ABC$, $m\angle C = 90$. If $AB = 5$ and $AC = 4$, which statement is *not* true?

- 1) $\cos A = \frac{4}{5}$
- 2) $\tan A = \frac{3}{4}$
- 3) $\sin B = \frac{4}{5}$
- 4) $\tan B = \frac{5}{3}$

157 Which set of coordinates is a solution of the equation $2x - y = 11$?

- 1) $(-6, 1)$
- 2) $(-1, 9)$
- 3) $(0, 11)$
- 4) $(2, -7)$

158 Marie currently has a collection of 58 stamps. If she buys s stamps each week for w weeks, which expression represents the total number of stamps she will have?

- 1) $58sw$
- 2) $58 + sw$
- 3) $58s + w$
- 4) $58 + s + w$

159 Noj is 5 years older than Jacob. The product of their ages is 84. How old is Noj?

- 1) 6
- 2) 7
- 3) 12
- 4) 14

160 Carol plans to sell twice as many magazine subscriptions as Jennifer. If Carol and Jennifer need to sell at least 90 subscriptions in all, which inequality could be used to determine how many subscriptions, x , Jennifer needs to sell?

- 1) $x \geq 45$
- 2) $2x \geq 90$
- 3) $2x - x \geq 90$
- 4) $2x + x \geq 90$

161 Given:

$A = \{\text{perfect square integers from 4-100, inclusive}\}$

$B = \{16, 36, 49, 64\}$

The complement of set B in the universal set A is

- 1) $\{9, 25, 81\}$
- 2) $\{4, 9, 25, 81, 100\}$
- 3) $\{1, 4, 9, 25, 81, 100\}$
- 4) $\{4, 16, 36, 49, 64, 100\}$

162 Which interval notation describes the set $S = \{x | 1 \leq x < 10\}$?

- 1) $[1, 10]$
- 2) $(1, 10]$
- 3) $[1, 10)$
- 4) $(1, 10)$

163 The expression $\frac{6 \times 10^{-7}}{3 \times 10^{-3}}$ is equivalent to

- 1) 2×10^4
- 2) 2×10^{10}
- 3) 2×10^{-4}
- 4) 2×10^{-10}

164 The diagram below shows right triangle LMP .

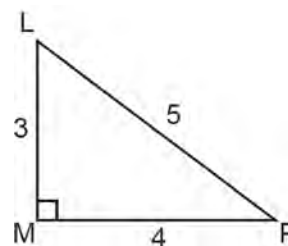

Which ratio represents the tangent of $\angle PLM$?

- 1) $\frac{3}{4}$
- 2) $\frac{3}{5}$
- 3) $\frac{4}{3}$
- 4) $\frac{5}{4}$

165 What is the sum of $\frac{2y}{y+5}$ and $\frac{10}{y+5}$ expressed in simplest form?

- 1) 1
- 2) 2
- 3) $\frac{12y}{y+5}$
- 4) $\frac{2y+10}{y+5}$

166 The menu for the high school cafeteria is shown below.

Main Course	Vegetable	Dessert	Beverage
veggie burger	corn	gelatin	milk
pizza	green beans	fruit salad	juice
tuna sandwich	carrots	yogurt	bottled water
frankfurter		cookie	
chicken tenders		ice cream cup	

Determine the number of possible meals consisting of a main course, a vegetable, a dessert, and a beverage that can be selected from the menu. Determine how many of these meals will include chicken tenders. If a student chooses pizza, corn or carrots, a dessert, and a beverage from the menu, determine the number of possible meals that can be selected.

167 In the diagram below, circle O is inscribed in square $ABCD$. The square has an area of 36.

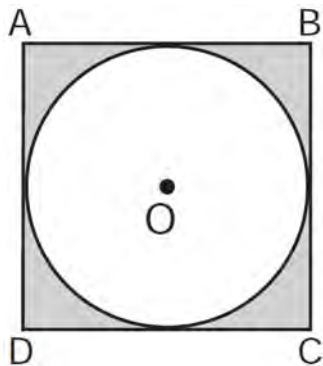

What is the area of the circle?

- 1) 9?
- 2) 6?
- 3) 3?
- 4) 36?

168 What is the solution of the system of equations shown in the graph below?

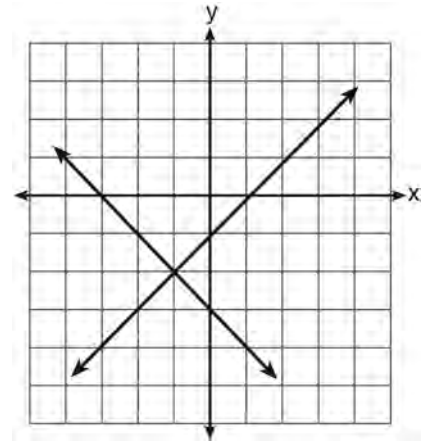

- 1) $(1, 0)$ and $(-3, 0)$
- 2) $(0, -3)$ and $(0, -1)$
- 3) $(-1, -2)$
- 4) $(-2, -1)$

169 The equation $3(4x) = (4x)3$ illustrates which property?

- 1) commutative
- 2) associative
- 3) distributive
- 4) multiplicative inverse

170 Which set builder notation describes $\{-2, -1, 0, 1, 2, 3\}$?

- 1) $\{x | -3 \leq x \leq 3, \text{ where } x \text{ is an integer}\}$
- 2) $\{x | -3 < x \leq 4, \text{ where } x \text{ is an integer}\}$
- 3) $\{x | -2 < x < 3, \text{ where } x \text{ is an integer}\}$
- 4) $\{x | -2 \leq x < 4, \text{ where } x \text{ is an integer}\}$

171 In right triangle ABC , $m\angle C = 90$, $\overline{AC} = 7$, and $\overline{AB} = 13$. What is the length of \overline{BC} ?

- 1) 6
- 2) 20
- 3) $\sqrt{120}$
- 4) $\sqrt{218}$

172 If five times a number is less than 55, what is the greatest possible integer value of the number?

- 1) 12
- 2) 11
- 3) 10
- 4) 9

173 Which equation represents a line that has a slope of $\frac{3}{4}$ and passes through the point $(2, 1)$?

- 1) $3y = 4x - 5$
- 2) $3y = 4x + 2$
- 3) $4y = 3x - 2$
- 4) $4y = 3x + 5$

174 Three storage bins contain colored blocks. Bin 1 contains 15 red and 14 blue blocks. Bin 2 contains 16 white and 15 blue blocks. Bin 3 contains 15 red and 15 white blocks. All of the blocks from the three bins are placed into one box. If one block is randomly selected from the box, which color block would most likely be picked? Justify your answer.

175 The graph of a parabola is represented by the equation $y = ax^2$ where a is a positive integer. If a is multiplied by 2, the new parabola will become

- 1) narrower and open downward
- 2) narrower and open upward
- 3) wider and open downward
- 4) wider and open upward

176 The expression $9a^2 - 64b^2$ is equivalent to

- 1) $(9a - 8b)(a + 8b)$
- 2) $(9a - 8b)(a - 8b)$
- 3) $(3a - 8b)(3a + 8b)$
- 4) $(3a - 8b)(3a - 8b)$

177 What is the solution of the equation $\frac{x+2}{2} = \frac{4}{x}$?

- 1) 1 and -8
- 2) 2 and -4
- 3) -1 and 8
- 4) -2 and 4

178 Using the line provided, construct a box-and-whisker plot for the 12 scores below.
26, 32, 19, 65, 57, 16, 28, 42, 40, 21, 38, 10



Determine the number of scores that lie above the 75th percentile.

- 179 The actual dimensions of a rectangle are 2.6 cm by 6.9 cm. Andy measures the sides as 2.5 cm by 6.8 cm. In calculating the area, what is the relative error, to the *nearest thousandth*?
- 1) 0.055
 - 2) 0.052
 - 3) 0.022
 - 4) 0.021

- 180 Which coordinates represent a point in the solution set of the system of inequalities shown below?

$$y \leq \frac{1}{2}x + 13$$

$$4x + 2y > 3$$

- 1) (-4, 1)
- 2) (-2, 2)
- 3) (1, -4)
- 4) (2, -2)

- 181 Which ratio represents the cosine of angle A in the right triangle below?

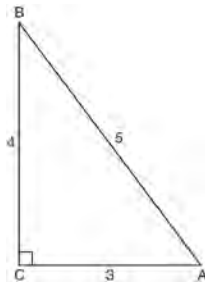

- 1) $\frac{3}{5}$
- 2) $\frac{5}{3}$
- 3) $\frac{4}{5}$
- 4) $\frac{4}{3}$

- 182 Which graph represents the inequality $y \geq x + 3$?

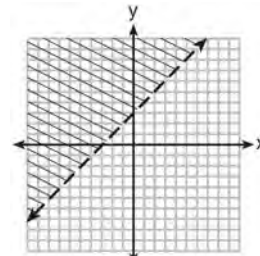

1)

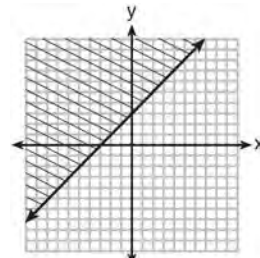

2)

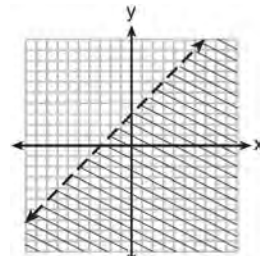

3)

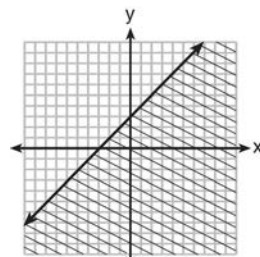

4)

- 183 When $2x^2 - 3x + 2$ is subtracted from $4x^2 - 5x + 2$, the result is

- 1) $2x^2 - 2x$
- 2) $-2x^2 + 2x$
- 3) $-2x^2 - 8x + 4$
- 4) $2x^2 - 8x + 4$

184 A scatter plot was constructed on the graph below and a line of best fit was drawn.

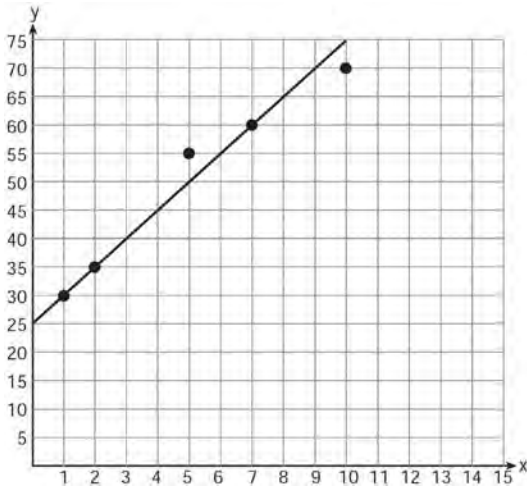

What is the equation of this line of best fit?

- 1) $y = x + 5$
- 2) $y = x + 25$
- 3) $y = 5x + 5$
- 4) $y = 5x + 25$

185 Which expression represents “5 less than twice x ”?

- 1) $2x - 5$
- 2) $5 - 2x$
- 3) $2(5 - x)$
- 4) $2(x - 5)$

186 The graph of $y = |x + 2|$ is shown below.

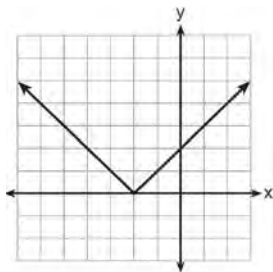

Which graph represents $y = -|x + 2|$?

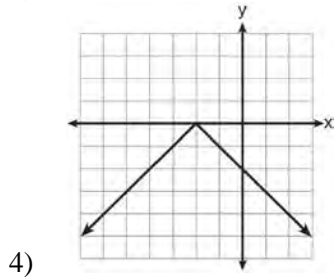
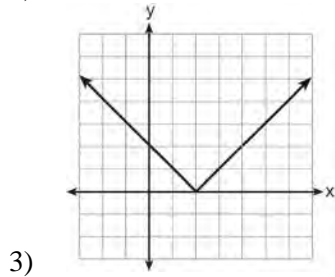
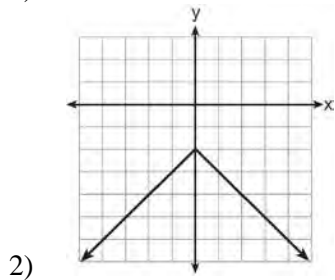
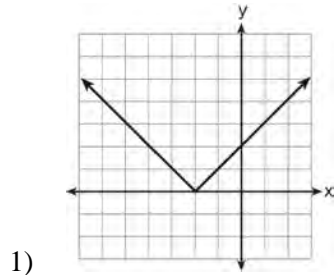

187 A jar contains five red marbles and three green marbles. A marble is drawn at random and not replaced. A second marble is then drawn from the jar. Find the probability that the first marble is red and the second marble is green. Find the probability that both marbles are red. Find the probability that both marbles are the same color.

188 Which expression can be used to change 75 kilometers per hour to meters per minute?

- 1) $\frac{75 \text{ km}}{1 \text{ hr}} \times \frac{1 \text{ km}}{1,000 \text{ m}} \times \frac{1 \text{ hr}}{60 \text{ min}}$
- 2) $\frac{75 \text{ km}}{1 \text{ hr}} \times \frac{1 \text{ km}}{1,000 \text{ m}} \times \frac{60 \text{ min}}{1 \text{ hr}}$
- 3) $\frac{75 \text{ km}}{1 \text{ hr}} \times \frac{1,000 \text{ m}}{1 \text{ km}} \times \frac{1 \text{ hr}}{60 \text{ min}}$
- 4) $\frac{75 \text{ km}}{1 \text{ hr}} \times \frac{1,000 \text{ m}}{1 \text{ km}} \times \frac{60 \text{ min}}{1 \text{ hr}}$

189 Which statement illustrates the additive identity property?

- 1) $6 + 0 = 6$
- 2) $-6 + 6 = 0$
- 3) $4(6 + 3) = 4(6) + 4(3)$
- 4) $(4 + 6) + 3 = 4 + (6 + 3)$

190 Which set of data can be classified as quantitative?

- 1) first names of students in a chess club
- 2) ages of students in a government class
- 3) hair colors of students in a debate club
- 4) favorite sports of students in a gym class

191 An art studio has a list of information posted with each sculpture that is for sale. Each entry in the list could be classified as quantitative *except* for the

- 1) cost
- 2) height
- 3) artist
- 4) weight

192 Express $4\sqrt{75}$ in simplest radical form.

193 On the set of axes below, solve the following system of equations graphically. State the coordinates of the solution.

$$y = 4x - 1$$

$$2x + y = 5$$

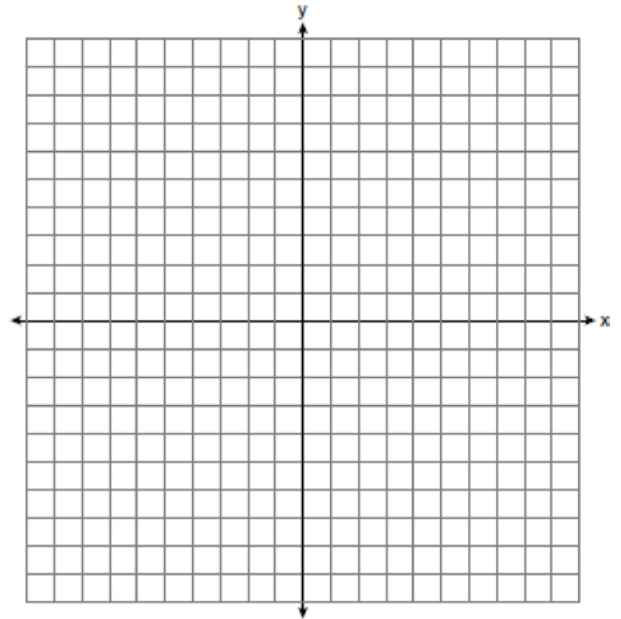

194 Which is the equation of a parabola that has the same vertex as the parabola represented by $y = x^2$, but is wider?

- 1) $y = x^2 + 2$
- 2) $y = x^2 - 2$
- 3) $y = 2x^2$
- 4) $y = \frac{1}{2}x^2$

195 Express $\sqrt{25} - 2\sqrt{3} + \sqrt{27} + 2\sqrt{9}$ in simplest radical form.

- 196 The cumulative frequency table below shows the length of time that 30 students spent text messaging on a weekend.

Minutes Used	Cumulative Frequency
31–40	2
31–50	5
31–60	10
31–70	19
31–80	30

Which 10-minute interval contains the first quartile?

- 1) 31 – 40
 - 2) 41 – 50
 - 3) 51 – 60
 - 4) 61 – 70
- 197 Which interval notation represents $-3 \leq x \leq 3$?
- 1) $[-3, 3]$
 - 2) $(-3, 3]$
 - 3) $[-3, 3)$
 - 4) $(-3, 3)$

- 198 Which value of x is in the solution set of $-3x + 8 \geq 14$?
- 1) -3
 - 2) -1
 - 3) 0
 - 4) 3

- 199 Monique has three sons who play football, two sons who play baseball, and one son who plays both sports. If all of her sons play baseball or football, how many sons does she have?

- 1) 5
- 2) 6
- 3) 3
- 4) 4

- 200 The probability it will rain tomorrow is $\frac{1}{2}$. The probability that our team will win tomorrow's basketball game is $\frac{3}{5}$. Which expression represents the probability that it will rain and that our team will *not* win the game?

- 1) $\frac{1}{2} + \frac{3}{5}$
- 2) $\frac{1}{2} + \frac{2}{5}$
- 3) $\frac{1}{2} \times \frac{3}{5}$
- 4) $\frac{1}{2} \times \frac{2}{5}$

- 201 The expression $\frac{2x+13}{2x+6} - \frac{3x-6}{2x+6}$ is equivalent to

- 1) $\frac{-x+19}{2(x+3)}$
- 2) $\frac{-x+7}{2(x+3)}$
- 3) $\frac{5x+19}{2(x+3)}$
- 4) $\frac{5x+7}{4x+12}$

202 The cost of three notebooks and four pencils is \$8.50. The cost of five notebooks and eight pencils is \$14.50. Determine the cost of one notebook and the cost of one pencil. [Only an algebraic solution can receive full credit.]

203 The expression $\frac{2x^2 + 10x - 28}{4x + 28}$ is equivalent to

- 1) $\frac{x - 2}{2}$
- 2) $x - 1$
- 3) $\frac{x + 2}{2}$
- 4) $\frac{x + 5}{2}$

204 Which expression is equivalent to $64 - x^2$?

- 1) $(8 - x)(8 - x)$
- 2) $(8 - x)(8 + x)$
- 3) $(x - 8)(x - 8)$
- 4) $(x - 8)(x + 8)$

205 What is the solution set of the system of equations

$$x + y = 5 \text{ and } y = x^2 - 25?$$

- 1) $\{(0, 5), (11, -6)\}$
- 2) $\{(5, 0), (-6, 11)\}$
- 3) $\{(-5, 0), (6, 11)\}$
- 4) $\{(-5, 10), (6, -1)\}$

206 The difference between two numbers is 28. The larger number is 8 less than twice the smaller number. Find *both* numbers. [Only an algebraic solution can receive full credit.]

207 Adrienne invested \$2000 in an account at a 3.5% interest rate compounded annually. She made no deposits or withdrawals on the account for 4 years. Determine, to the *nearest dollar*, the balance in the account after the 4 years.

208 A cube with faces numbered 1 through 6 is rolled 75 times, and the results are given in the table below.

Number	Frequency
1	7
2	22
3	14
4	6
5	20
6	6

Based on these results, which statement is true?

- 1) $P(\text{odd}) < P(\text{even})$
- 2) $P(3 \text{ or less}) < P(\text{odd})$
- 3) $P(\text{even}) < P(2 \text{ or } 4)$
- 4) $P(2 \text{ or } 4) < P(3 \text{ or less})$

209 A cube, with faces numbered 1 to 6, is rolled, and a penny is tossed at the same time. How many elements in the sample space consist of an even number and a tail?

- 1) 12
- 2) 2
- 3) 3
- 4) 4

210 The sum of three consecutive odd integers is 18 less than five times the middle number. Find the three integers. [Only an algebraic solution can receive full credit.]

211 A designer created a garden, as shown in the diagram below. The garden consists of four quarter-circles of equal size inside a square. The designer put a fence around both the inside and the outside of the garden.

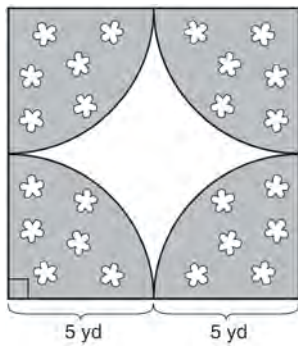

Which expression represents the amount of fencing, in yards, that the designer used for the fence?

- 1) $40 + 10\pi$
- 2) $40 + 25\pi$
- 3) $100 + 10\pi$
- 4) $100 + 25\pi$

212 The solution of the equation $5 - 2x = -4x - 7$ is

- 1) 1
- 2) 2
- 3) -2
- 4) -6

213 The sum of $8n^2 - 3n + 10$ and $-3n^2 - 6n - 7$ is

- 1) $5n^2 - 9n + 3$
- 2) $5n^2 - 3n - 17$
- 3) $-11n^2 - 9n - 17$
- 4) $-11n^2 - 3n + 3$

214 On the set of axes below, graph the following system of equations. Using the graph, determine and state *all* solutions of the system of equations.

$$y = -x^2 - 2x + 3$$

$$y + 1 = -2x$$

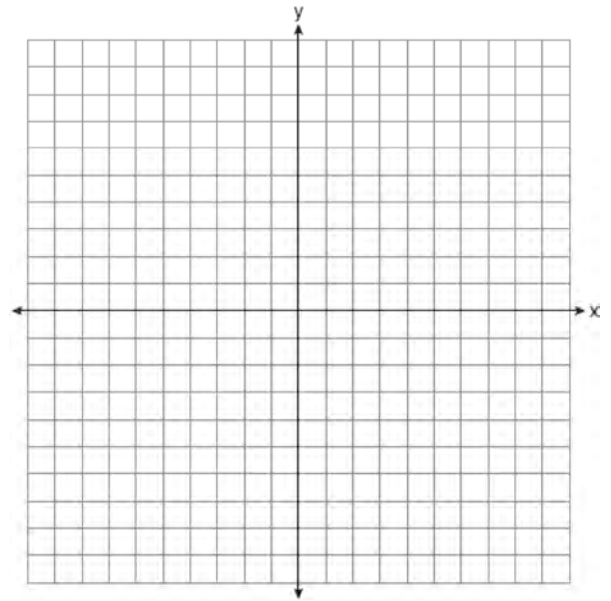

215 The value of the expression $6! + \frac{5!(3!)}{4!} - 10$ is

- 1) 50
- 2) 102
- 3) 740
- 4) 750

216 Mike buys his ice cream packed in a rectangular prism-shaped carton, while Carol buys hers in a cylindrical-shaped carton. The dimensions of the prism are 5 inches by 3.5 inches by 7 inches. The cylinder has a diameter of 5 inches and a height of 7 inches. Which container holds more ice cream? Justify your answer. Determine, to the *nearest tenth of a cubic inch*, how much more ice cream the larger container holds.

217 In right triangle ABC shown below, $AC = 29$ inches, $AB = 17$ inches, and $m\angle ABC = 90$. Find the number of degrees in the measure of angle BAC , to the *nearest degree*.

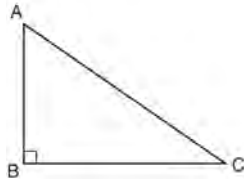

Find the length of \overline{BC} to the *nearest inch*.

218 If the point $(5, k)$ lies on the line represented by the equation $2x + y = 9$, the value of k is

- 1) 1
- 2) 2
- 3) -1
- 4) -2

219 Which equation represents a line that is parallel to the y -axis and passes through the point $(4, 3)$?

- 1) $x = 3$
- 2) $x = 4$
- 3) $y = 3$
- 4) $y = 4$

220 Wendy measures the floor in her rectangular bedroom for new carpeting. Her measurements are 24 feet by 14 feet. The actual measurements are 24.2 feet by 14.1 feet. Determine the relative error in calculating the area of her bedroom. Express your answer as a decimal to the *nearest thousandth*.

221 A sandwich consists of one type of bread, one type of meat, and one type of cheese. The possible choices are listed below.

Bread: white, rye

Meat: ham, turkey, beef

Cheese: American, Swiss

Draw a tree diagram or list a sample space of all the possible different sandwiches consisting of one type of bread, one type of meat, and one type of cheese. Determine the number of sandwiches that will *not* include turkey. Determine the number of sandwiches that will include rye bread and Swiss cheese.

222 How many solutions are there for the following system of equations?

$$y = x^2 - 5x + 3$$

$$y = x - 6$$

- 1) 1
- 2) 2
- 3) 3
- 4) 0

223 A jogger ran at a rate of 5.4 miles per hour. Find the jogger's *exact* rate, in feet per minute.

1 mile = 5,280 feet

224 A large company must choose between two types of passwords to log on to a computer. The first type is a four-letter password using any of the 26 letters of the alphabet, without repetition of letters. The second type is a six-digit password using the digits 0 through 9, with repetition of digits allowed. Determine the number of possible four-letter passwords. Determine the number of possible six-digit passwords. The company has 500,000 employees and needs a different password for each employee. State which type of password the company should choose. Explain your answer.

225 Express in simplest form: $\frac{x^2 - 1}{x^2 + 3x + 2}$

226 Miller's Department Store is having a sale with a 25% discount on mattresses. If the sales tax rate is 8%, how much change will Frank receive from \$800 if he purchases a mattress regularly priced at \$895 during this sale?

227 Three fair coins are tossed. What is the probability that two heads and one tail appear?

- 1) $\frac{1}{8}$
- 2) $\frac{3}{8}$
- 3) $\frac{3}{6}$
- 4) $\frac{2}{3}$

228 Which table shows bivariate data?

1)

Age (yr)	Frequency
14	12
15	21
16	14
17	19
18	15

2)

Type of Car	Average Gas Mileage (mpg)
van	25
SUV	23
luxury	26
compact	28
pickup	22

3)

Time Spent Studying (hr)	Test Grade (%)
1	65
2	72
3	83
4	85
5	92

4)

Day	Temperature (degrees F)
Monday	63
Tuesday	58
Wednesday	72
Thursday	74
Friday	78

229 Solve algebraically for x : $2(x - 4) \geq \frac{1}{2}(5 - 3x)$

230 On the set of axes below, graph $y = 3^x$ over the interval $-1 \leq x \leq 2$.

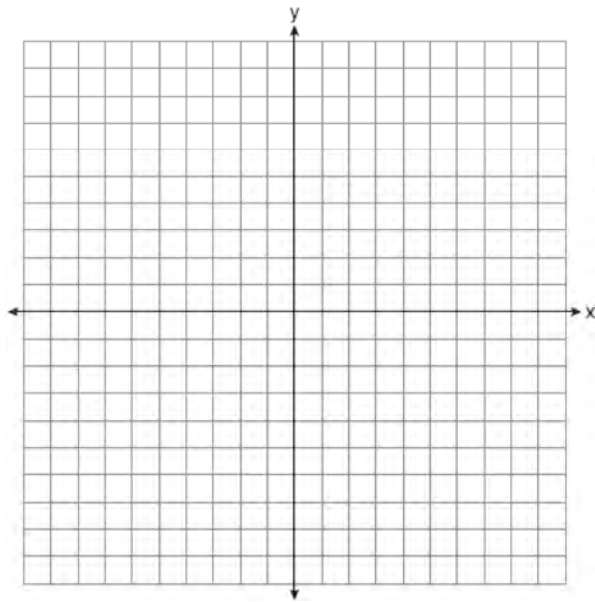

231 The box-and-whisker plot below represents the ages of 12 people.

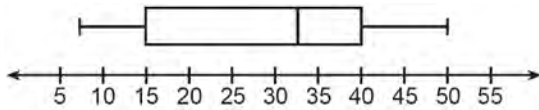

What percentage of these people are age 15 or older?

- 1) 25
- 2) 35
- 3) 75
- 4) 85

232 State the value of the expression

$$\frac{(4.1 \times 10^2)(2.4 \times 10^3)}{(1.5 \times 10^7)} \text{ in scientific notation.}$$

233 The following cumulative frequency histogram shows the distances swimmers completed in a recent swim test.

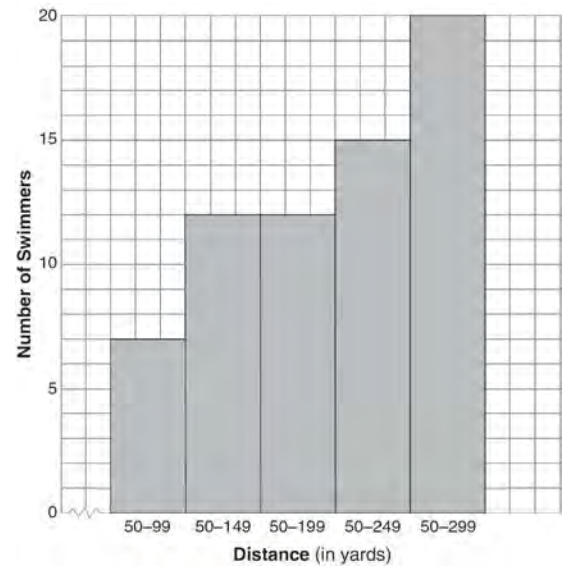

Based on the cumulative frequency histogram, determine the number of swimmers who swam between 200 and 249 yards. Determine the number of swimmers who swam between 150 and 199 yards. Determine the number of swimmers who took the swim test.

234 A school newspaper will survey students about the quality of the school's lunch program. Which method will create the *least* biased results?

- 1) Twenty-five vegetarians are randomly surveyed.
- 2) Twenty-five students are randomly chosen from each grade level.
- 3) Students who dislike the school's lunch program are chosen to complete the survey.
- 4) A booth is set up in the cafeteria for the students to voluntarily complete the survey.

Integrated Algebra Regents at Random

235 When $16x^3 - 12x^2 + 4x$ is divided by $4x$, the quotient is

- 1) $12x^2 - 8x$
- 2) $12x^2 - 8x + 1$
- 3) $4x^2 - 3x$
- 4) $4x^2 - 3x + 1$

236 Doug has four baseball caps: one tan, one blue, one red, and one green. He also has three jackets: one blue, one red, and one white. Draw a tree diagram or list a sample space to show all possible outfits consisting of one baseball cap and one jacket. Find the number of Doug's outfits that consist of a cap and a jacket that are different colors. On Spirit Day, Doug wants to wear either green or white, his school's colors. Find the number of his outfits from which he can choose.

237 What is the slope of a line represented by the equation $2y = x - 4$?

- 1) 1
- 2) $\frac{1}{2}$
- 3) -1
- 4) $-\frac{1}{2}$

238 Which data can be classified as quantitative?

- 1) favorite stores at which you shop
- 2) U.S. Representatives and their home states
- 3) sales tax rate in each New York county
- 4) opinion of a freshman on the color of Paul's shirt

239 The box-and-whisker plot shown below represents the number of magazine subscriptions sold by members of a club.

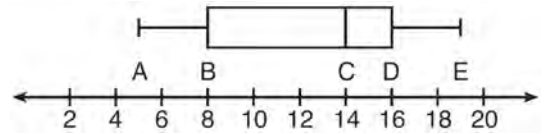

Which statistical measures do points B , D , and E represent, respectively?

- 1) minimum, median, maximum
- 2) first quartile, median, third quartile
- 3) first quartile, third quartile, maximum
- 4) median, third quartile, maximum

240 An example of an equation is

- 1) $2x^2 - 4x + 12$
- 2) $|x - 6|$
- 3) $4(x + 6)(x - 2)$
- 4) $2x = x^2 + 3$

241 Express $\frac{\sqrt{84}}{2\sqrt{3}}$ in simplest radical form.

242 The roots of the equation $2x^2 - 8x = 0$ are

- 1) -2 and 2
- 2) 0, -2 and 2
- 3) 0 and -4
- 4) 0 and 4

243 What is an equation of the line that passes through the point $(-2, -8)$ and has a slope of 3?

- 1) $y = 3x - 2$
- 2) $y = 3x - 22$
- 3) $y = 3x + 2$
- 4) $y = 3x + 22$

244 If $abx - 5 = 0$, what is x in terms of a and b ?

- 1) $x = \frac{5}{ab}$
- 2) $x = -\frac{5}{ab}$
- 3) $x = 5 - ab$
- 4) $x = ab - 5$

245 Jonathan drove to the airport to pick up his friend. A rainstorm forced him to drive at an average speed of 45 mph, reaching the airport in 3 hours. He drove back home at an average speed of 55 mph. How long, to the nearest tenth of an hour, did the trip home take him?

- 1) 2.0 hours
- 2) 2.5 hours
- 3) 2.8 hours
- 4) 3.7 hours

246 Which graph represents the solution set of $2x - 5 < 3$?

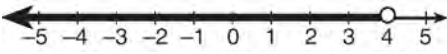
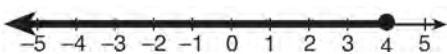
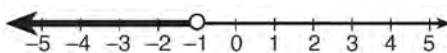
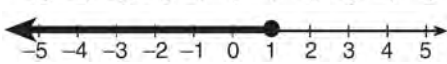
- 1) 
- 2) 
- 3) 
- 4) 

247 Which graph represents the solution of $2y + 6 > 4x$?

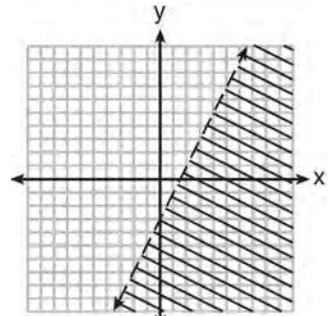

1)

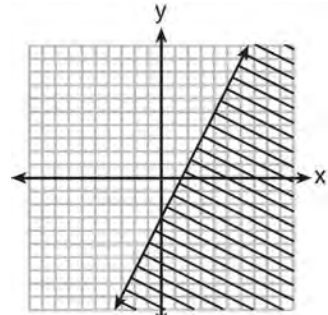

2)

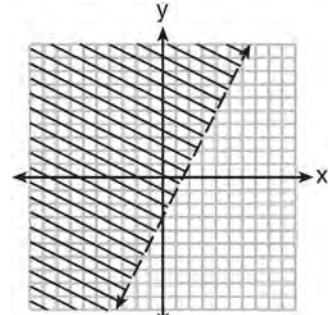

3)

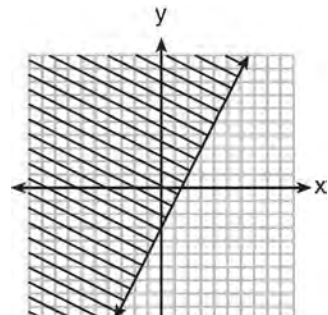

4)

- 248 Which statement regarding biased sampling is *false*?
- 1) Online sampling is biased because only the people who happen to visit the web site will take the survey.
 - 2) A radio call-in survey is biased because only people who feel strongly about the topic will respond.
 - 3) A survey handed to every third person leaving a library is biased because everyone leaving the library was not asked to participate.
 - 4) Asking for experts to take a survey is biased because they may have particular knowledge of the topic.

249 The expression $\frac{2n}{5} + \frac{3n}{2}$ is equivalent to

- 1) $\frac{5n}{7}$
- 2) $\frac{6n^2}{10}$
- 3) $\frac{19n}{10}$
- 4) $\frac{7n}{10}$

250 Which fraction represents $\frac{x^2 - 25}{x^2 - x - 20}$ expressed in simplest form?

- 1) $\frac{5}{4}$
- 2) $\frac{x - 5}{x - 4}$
- 3) $\frac{x + 5}{x + 4}$
- 4) $\frac{25}{x + 20}$

- 251 On the set of axes below, solve the following system of equations graphically for all values of x and y . State the coordinates of all solutions.

$$y = x^2 + 4x - 5$$

$$y = 2x + 3$$

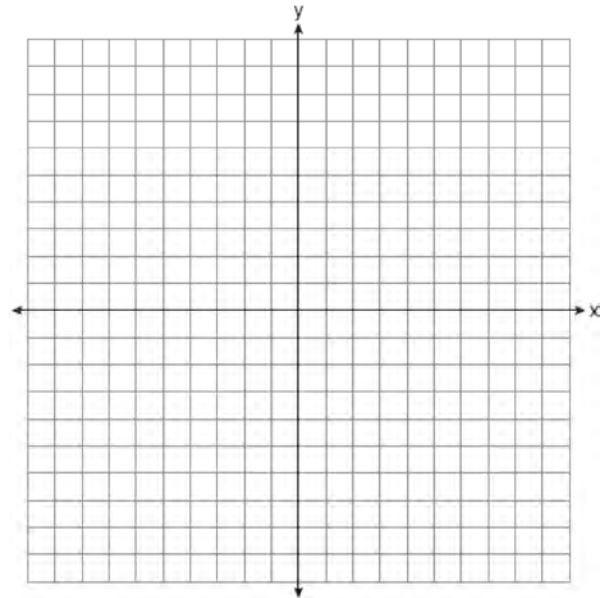

- 252 From the top of an apartment building, the angle of depression to a car parked on the street below is 38 degrees, as shown in the diagram below. The car is parked 80 feet from the base of the building. Find the height of the building, to the *nearest tenth of a foot*.

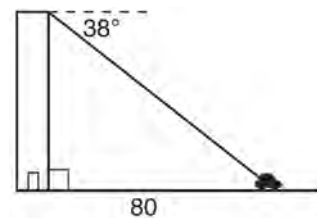

253 The width of a rectangle is 4 less than half the length. If ℓ represents the length, which equation could be used to find the width, w ?

- 1) $w = \frac{1}{2}(4 - \ell)$
- 2) $w = \frac{1}{2}(\ell - 4)$
- 3) $w = \frac{1}{2}\ell - 4$
- 4) $w = 4 - \frac{1}{2}\ell$

254 The cumulative frequency table below shows the number of minutes 31 students spent text messaging on a weekend.

Text-Use Interval (minutes)	Cumulative Frequency
41–50	2
41–60	5
41–70	10
41–80	19
41–90	31

Determine which 10-minute interval contains the median. Justify your choice.

255 What is the solution of the system of equations below?

$$2x + 3y = 7$$

$$x + y = 3$$

- 1) (1, 2)
- 2) (2, 1)
- 3) (4, -1)
- 4) (4, 1)

256 Julie has three children whose ages are consecutive odd integers. If x represents the youngest child's age, which expression represents the sum of her children's ages?

- 1) $3x + 3$
- 2) $3x + 4$
- 3) $3x + 5$
- 4) $3x + 6$

257 When $x = 4$, the value of $2x^0 + x!$ is

- 1) 24
- 2) 25
- 3) 26
- 4) 28

258 Graph and label the functions $y = |x|$ and $y = |2x|$ on the set of axes below.

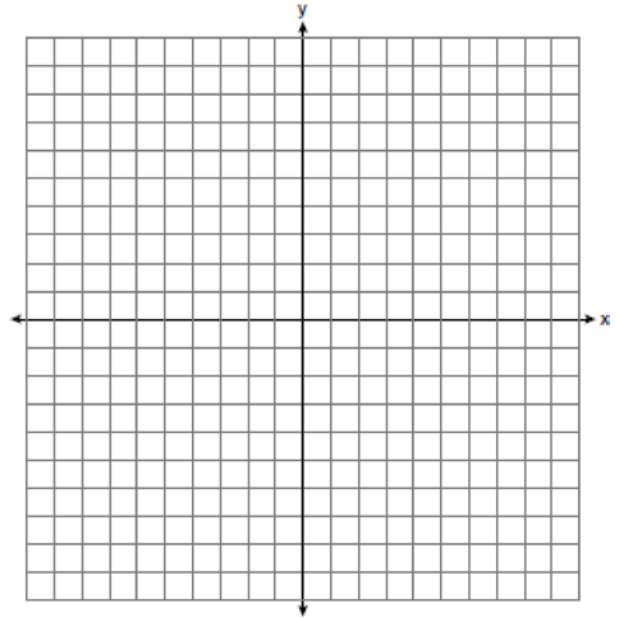

Explain how increasing the coefficient of x affects the graph of $y = |x|$.

259 Which graph represents the exponential decay of a radioactive element?

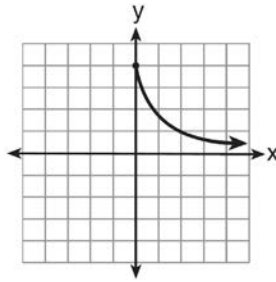
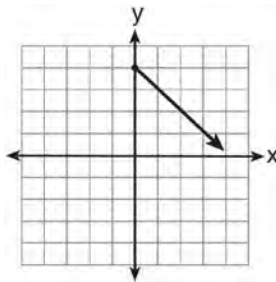
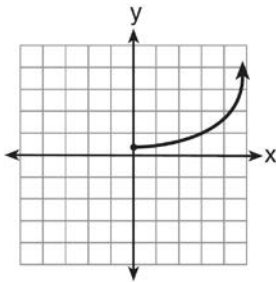
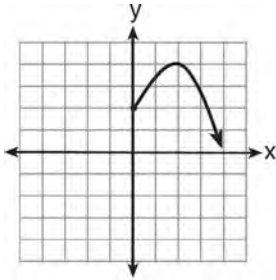

260 What is the result when $4x^2 - 17x + 36$ is subtracted from $2x^2 - 5x + 25$?

- 1) $6x^2 - 22x + 61$
- 2) $2x^2 - 12x + 11$
- 3) $-2x^2 - 22x + 61$
- 4) $-2x^2 + 12x - 11$

261 Two cubes with sides numbered 1 through 6 were rolled 20 times. Their sums are recorded in the table below.

4	9	8	9	2
9	4	6	12	10
8	7	9	11	10
8	7	9	3	5

What is the empirical probability of rolling a sum of 9?

- 1) $\frac{4}{20}$
- 2) $\frac{5}{20}$
- 3) $\frac{4}{36}$
- 4) $\frac{5}{36}$

262 The length and width of a rectangle are 48 inches and 40 inches. To the *nearest inch*, what is the length of its diagonal?

- 1) 27
- 2) 62
- 3) 88
- 4) 90

263 Kirsten invested \$1000 in an account at an annual interest rate of 3%. She made no deposits or withdrawals on the account for 5 years. The interest was compounded annually. Find the balance in the account, to the *nearest cent*, at the end of 5 years.

264 Which equation illustrates the multiplicative inverse property?

- 1) $a \cdot 1 = a$
- 2) $a \cdot 0 = 0$
- 3) $a\left(\frac{1}{a}\right) = 1$
- 4) $(-a)(-a) = a^2$

265 Jeremy is hosting a Halloween party for 80 children. He will give each child *at least* one candy bar. If each bag of candy contains 18 candy bars, which inequality can be used to determine how many bags, c , Jeremy will need to buy?

- 1) $18c \geq 80$
- 2) $18c \leq 80$
- 3) $\frac{c}{18} \geq 80$
- 4) $\frac{c}{18} \leq 80$

266 A figure consists of a square and a semicircle, as shown in the diagram below.

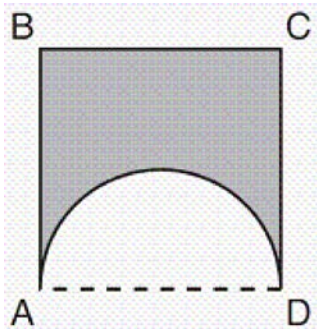

If the length of a side of the square is 6, what is the area of the shaded region?

- 1) $36 - 3\pi$
- 2) $36 - 4.5\pi$
- 3) $36 - 6\pi$
- 4) $36 - 9\pi$

267 The greatest common factor of $3m^2n + 12mn^2$ is?

- 1) $3n$
- 2) $3m$
- 3) $3mn$
- 4) $3mn^2$

268 Which relation is *not* a function?

- 1) $\{(2, 4), (1, 2), (0, 0), (-1, 2), (-2, 4)\}$
- 2) $\{(2, 4), (1, 1), (0, 0), (-1, 1), (-2, 4)\}$
- 3) $\{(2, 2), (1, 1), (0, 0), (-1, 1), (-2, 2)\}$
- 4) $\{(2, 2), (1, 1), (0, 0), (1, -1), (2, -2)\}$

269 Terry estimated the length of the edge of a cube to be 5 cm. The actual length of the side is 5.2 cm. Find the relative error of the surface area of the cube, to the *nearest thousandth*.

270 What is the vertex of the graph of the equation

$$y = 3x^2 + 6x + 1?$$

- 1) $(-1, -2)$
- 2) $(-1, 10)$
- 3) $(1, -2)$
- 4) $(1, 10)$

271 Given: $U = \{x | 0 < x < 10 \text{ and } x \text{ is an integer}\}$

$$S = \{x | 0 < x < 10 \text{ and } x \text{ is an odd integer}\}$$

The complement of set S within the universal set U is

- 1) $\{0, 2, 4, 6, 8, 10\}$
- 2) $\{2, 4, 6, 8, 10\}$
- 3) $\{0, 2, 4, 6, 8\}$
- 4) $\{2, 4, 6, 8\}$

Integrated Algebra Regents at Random

272 There is a negative correlation between the number of hours a student watches television and his or her social studies test score. Which scatter plot below displays this correlation?

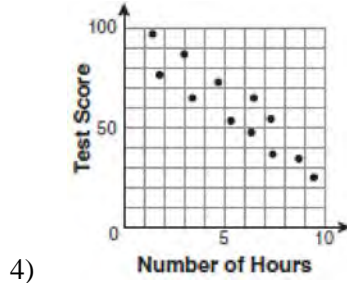
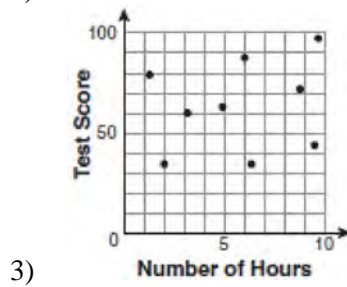
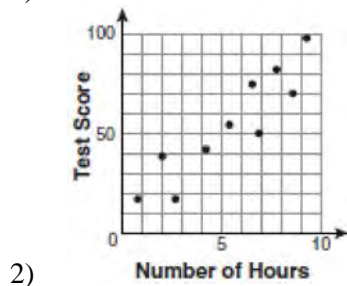
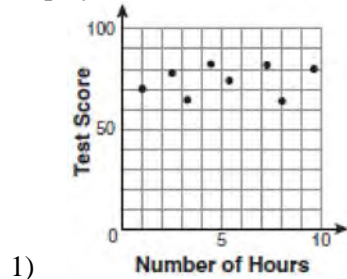

273 Which ordered pair is a solution to the system of equations $y = x$ and $y = x^2 - 2$?

- 1) $(-2, -2)$
- 2) $(-1, 1)$
- 3) $(0, 0)$
- 4) $(2, 2)$

274 Maureen tracks the range of outdoor temperatures over three days. She records the following information.

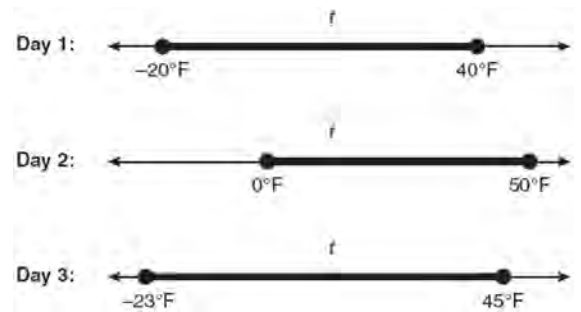

Express the intersection of the three sets as an inequality in terms of temperature, t .

275 What is an equation for the line that passes through the coordinates $(2, 0)$ and $(0, 3)$?

- 1) $y = -\frac{3}{2}x + 3$
- 2) $y = -\frac{3}{2}x - 3$
- 3) $y = -\frac{2}{3}x + 2$
- 4) $y = -\frac{2}{3}x - 2$

- 276 Tanya runs diagonally across a rectangular field that has a length of 40 yards and a width of 30 yards, as shown in the diagram below.

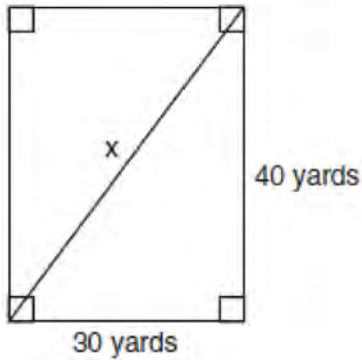

What is the length of the diagonal, in yards, that Tanya runs?

- 1) 50
2) 60
3) 70
4) 80
- 277 A prom ticket at Smith High School is \$120. Tom is going to save money for the ticket by walking his neighbor's dog for \$15 per week. If Tom already has saved \$22, what is the minimum number of weeks Tom must walk the dog to earn enough to pay for the prom ticket?
- 278 The solution to the equation $x^2 - 6x = 0$ is
- 1) 0, only
2) 6, only
3) 0 and 6
4) $\pm\sqrt{6}$

- 279 Mrs. Smith wrote "Eight less than three times a number is greater than fifteen" on the board. If x represents the number, which inequality is a correct translation of this statement?

- 1) $3x - 8 > 15$
2) $3x - 8 < 15$
3) $8 - 3x > 15$
4) $8 - 3x < 15$

- 280 Which inequality is represented by the graph below?

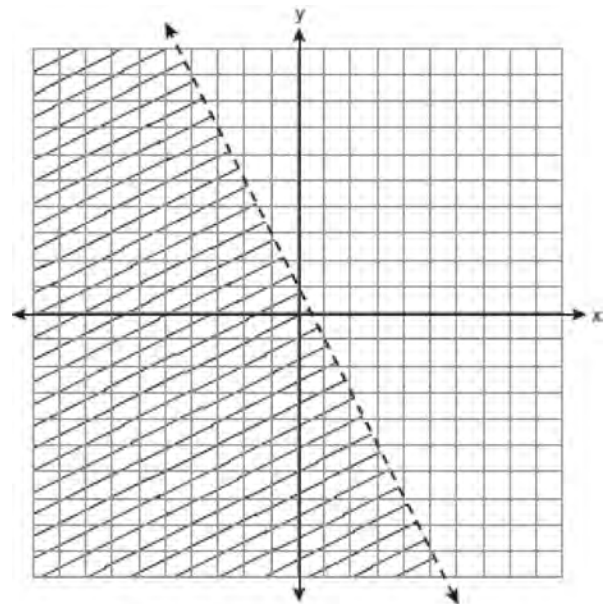

- 1) $y < 2x + 1$
2) $y < -2x + 1$
3) $y < \frac{1}{2}x + 1$
4) $y < -\frac{1}{2}x + 1$

281 What is $\frac{6}{4a} - \frac{2}{3a}$ expressed in simplest form?

- 1) $\frac{4}{a}$
- 2) $\frac{5}{6a}$
- 3) $\frac{8}{7a}$
- 4) $\frac{10}{12a}$

282 What is the solution of $\frac{k+4}{2} = \frac{k+9}{3}$?

- 1) 1
- 2) 5
- 3) 6
- 4) 14

283 Which type of graph is shown in the diagram below?

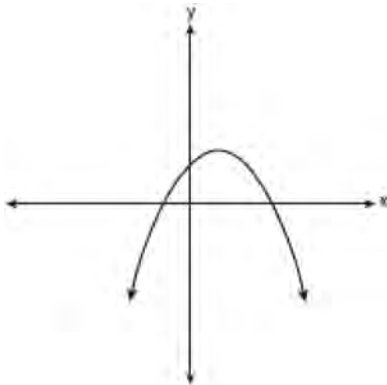

- 1) absolute value
- 2) exponential
- 3) linear
- 4) quadratic

284 A spinner is divided into eight equal regions as shown in the diagram below.

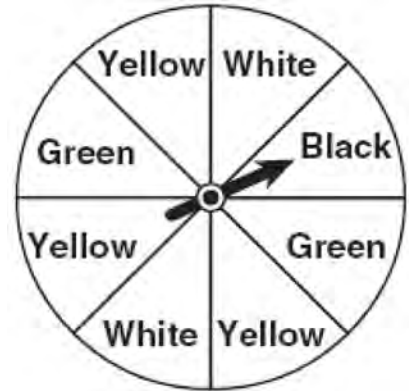

Which event is most likely to occur in one spin?

- 1) The arrow will land in a green or white area.
- 2) The arrow will land in a green or black area.
- 3) The arrow will land in a yellow or black area.
- 4) The arrow will land in a yellow or green area.

285 Which data set describes a situation that could be classified as qualitative?

- 1) the ages of the students in Ms. Marshall's Spanish class
- 2) the test scores of the students in Ms. Fitzgerald's class
- 3) the favorite ice cream flavor of each of Mr. Hayden's students
- 4) the heights of the players on the East High School basketball team

286 Which interval notation represents the set of all numbers from 2 through 7, inclusive?

- 1) $(2, 7]$
- 2) $(2, 7)$
- 3) $[2, 7)$
- 4) $[2, 7]$

- 287 A designer created the logo shown below. The logo consists of a square and four quarter-circles of equal size.

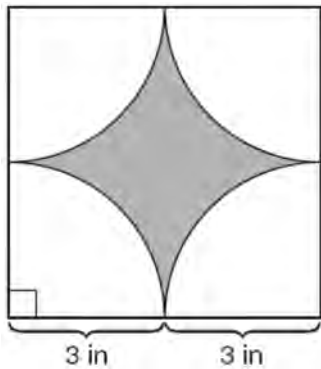

Express, in terms of π , the exact area, in square inches, of the shaded region.

- 288 The groundskeeper is replacing the turf on a football field. His measurements of the field are 130 yards by 60 yards. The actual measurements are 120 yards by 54 yards. Which expression represents the relative error in the measurement?

- 1) $\frac{(130)(60) - (120)(54)}{(120)(54)}$
- 2) $\frac{(120)(54)}{(130)(60) - (120)(54)}$
- 3) $\frac{(130)(60) - (120)(54)}{(130)(60)}$
- 4) $\frac{(130)(60)}{(130)(60) - (120)(54)}$

- 289 What is an equation of the line that passes through the point $(4, -6)$ and has a slope of -3 ?

- 1) $y = -3x + 6$
- 2) $y = -3x - 6$
- 3) $y = -3x + 10$
- 4) $y = -3x + 14$

- 290 Don placed a ladder against the side of his house as shown in the diagram below.

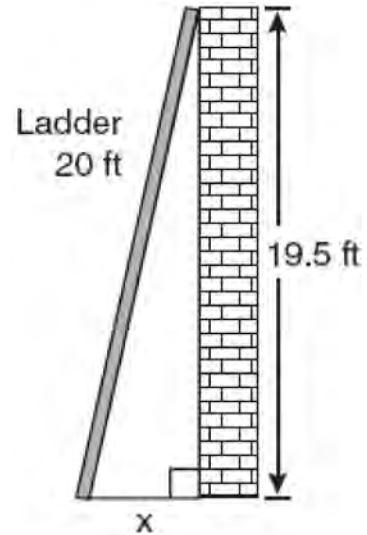

Which equation could be used to find the distance, x , from the foot of the ladder to the base of the house?

- 1) $x = 20 - 19.5$
- 2) $x = 20^2 - 19.5^2$
- 3) $x = \sqrt{20^2 - 19.5^2}$
- 4) $x = \sqrt{20^2 + 19.5^2}$

- 291 Erica is conducting a survey about the proposed increase in the sports budget in the Hometown School District. Which survey method would likely contain the most bias?

- 1) Erica asks every third person entering the Hometown Grocery Store.
- 2) Erica asks every third person leaving the Hometown Shopping Mall this weekend.
- 3) Erica asks every fifth student entering Hometown High School on Monday morning.
- 4) Erica asks every fifth person leaving Saturday's Hometown High School football game.

- 292 Which data set describes a situation that could be classified as qualitative?
- 1) the elevations of the five highest mountains in the world
 - 2) the ages of presidents at the time of their inauguration
 - 3) the opinions of students regarding school lunches
 - 4) the shoe sizes of players on the basketball team

- 293 The sign shown below is posted in front of a roller coaster ride at the Wadsworth County Fairgrounds.

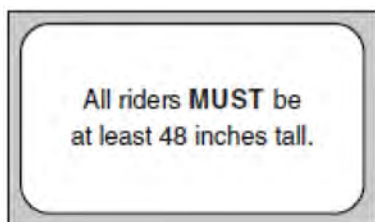

If h represents the height of a rider in inches, what is a correct translation of the statement on this sign?

- 1) $h < 48$
 - 2) $h > 48$
 - 3) $h \leq 48$
 - 4) $h \geq 48$
- 294 Pam is playing with red and black marbles. The number of red marbles she has is three more than twice the number of black marbles she has. She has 42 marbles in all. How many red marbles does Pam have?
- 1) 13
 - 2) 15
 - 3) 29
 - 4) 33

- 295 Express the product of $3\sqrt{20}(2\sqrt{5} - 7)$ in simplest radical form.

- 296 In a linear equation, the independent variable increases at a constant rate while the dependent variable decreases at a constant rate. The slope of this line is
- 1) zero
 - 2) negative
 - 3) positive
 - 4) undefined

- 297 Which expression represents $\frac{(2x^3)(8x^5)}{4x^6}$ in simplest form?

- 1) x^2
- 2) x^9
- 3) $4x^2$
- 4) $4x^9$

- 298 Write an equation that represents the line that passes through the points $(5, 4)$ and $(-5, 0)$.

- 299 The Hudson Record Store is having a going-out-of-business sale. CDs normally sell for \$18.00. During the first week of the sale, all CDs will sell for \$15.00. Written as a fraction, what is the rate of discount? What is this rate expressed as a percent? Round your answer to the *nearest hundredth of a percent*. During the second week of the sale, the same CDs will be on sale for 25% off the *original price*. What is the price of a CD during the second week of the sale?

- 300 Which expression represents $\frac{2x^2 - 12x}{x - 6}$ in simplest form?
- 1) 0
 - 2) $2x$
 - 3) $4x$
 - 4) $2x + 2$

- 301 Nancy's rectangular garden is represented in the diagram below.

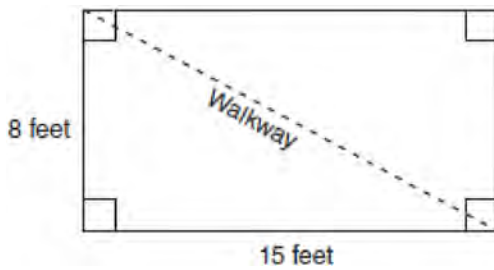

If a diagonal walkway crosses her garden, what is its length, in feet?

- 1) 17
 - 2) 22
 - 3) $\sqrt{161}$
 - 4) $\sqrt{529}$
- 302 Which property is illustrated by the equation $ax + ay = a(x + y)$?
- 1) associative
 - 2) commutative
 - 3) distributive
 - 4) identity

- 303 Factor completely: $4x^3 - 36x$

- 304 For 10 days, Romero kept a record of the number of hours he spent listening to music. The information is shown in the table below.

Day	1	2	3	4	5	6	7	8	9	10
Hours	9	3	2	6	8	6	10	4	5	2

Which scatter plot shows Romero's data graphically?

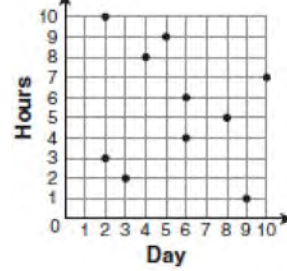

1)

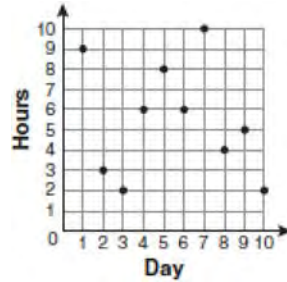

2)

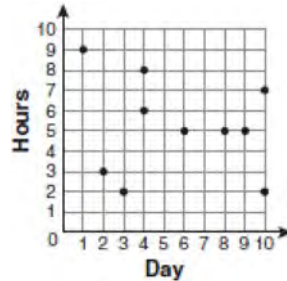

3)

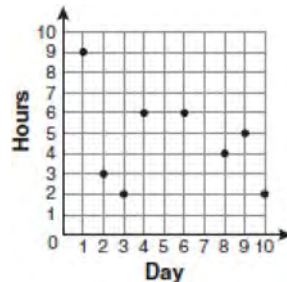

4)

305 Which equation represents a line parallel to the x -axis?

- 1) $x = 5$
- 2) $y = 10$
- 3) $x = \frac{1}{3}y$
- 4) $y = 5x + 17$

306 Rhonda has \$1.35 in nickels and dimes in her pocket. If she has six more dimes than nickels, which equation can be used to determine x , the number of nickels she has?

- 1) $0.05(x + 6) + 0.10x = 1.35$
- 2) $0.05x + 0.10(x + 6) = 1.35$
- 3) $0.05 + 0.10(6x) = 1.35$
- 4) $0.15(x + 6) = 1.35$

307 What is the slope of the line that passes through the points $(-5, 4)$ and $(15, -4)$?

- 1) $-\frac{2}{5}$
- 2) 0
- 3) $-\frac{5}{2}$
- 4) undefined

308 What is the slope of the line that passes through the points $(-6, 1)$ and $(4, -4)$?

- 1) -2
- 2) 2
- 3) $-\frac{1}{2}$
- 4) $\frac{1}{2}$

309 What is an equation of the line that passes through the point $(3, -1)$ and has a slope of 2?

- 1) $y = 2x + 5$
- 2) $y = 2x - 1$
- 3) $y = 2x - 4$
- 4) $y = 2x - 7$

310 Which graph represents a function?

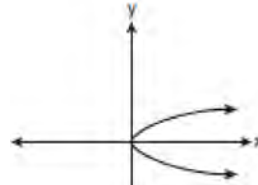

1)

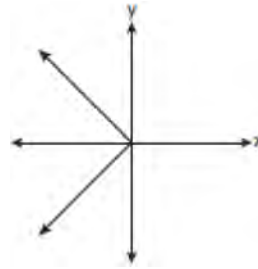

2)

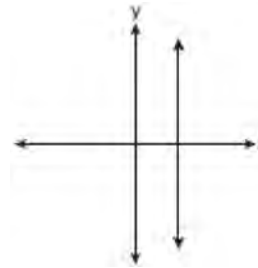

3)

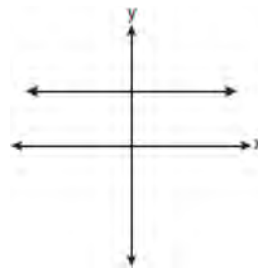

4)

- 311 Alex earned scores of 60, 74, 82, 87, 87, and 94 on his first six algebra tests. What is the relationship between the measures of central tendency of these scores?
- 1) median < mode < mean
 - 2) mean < mode < median
 - 3) mode < median < mean
 - 4) mean < median < mode

- 312 The statement $2 + 0 = 2$ is an example of the use of which property of real numbers?
- 1) associative
 - 2) additive identity
 - 3) additive inverse
 - 4) distributive

- 313 Which ordered pair is a solution of the system of equations $y = x^2 - x - 20$ and $y = 3x - 15$?
- 1) $(-5, -30)$
 - 2) $(-1, -18)$
 - 3) $(0, 5)$
 - 4) $(5, -1)$

- 314 What is the value of x in the equation

$$\frac{2}{x} - 3 = \frac{26}{x}?$$

- 1) -8
- 2) $-\frac{1}{8}$
- 3) $\frac{1}{8}$
- 4) 8

- 315 Which ordered pair is in the solution set of the following system of inequalities?

$$y < \frac{1}{2}x + 4$$

$$y \geq -x + 1$$

- 1) $(-5, 3)$
- 2) $(0, 4)$
- 3) $(3, -5)$
- 4) $(4, 0)$

- 316 A movie theater recorded the number of tickets sold daily for a popular movie during the month of June. The box-and-whisker plot shown below represents the data for the number of tickets sold, in hundreds.

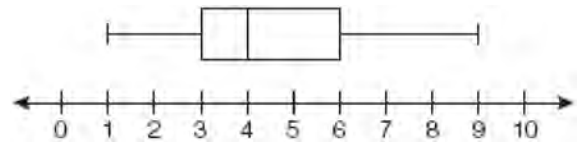

Which conclusion can be made using this plot?

- 1) The second quartile is 600.
- 2) The mean of the attendance is 400.
- 3) The range of the attendance is 300 to 600.
- 4) Twenty-five percent of the attendance is between 300 and 400.

- 317 What is the sum of $\frac{d}{2}$ and $\frac{2d}{3}$ expressed in simplest form?

- 1) $\frac{3d}{5}$
- 2) $\frac{3d}{6}$
- 3) $\frac{7d}{5}$
- 4) $\frac{7d}{6}$

- 318 The faces of a cube are numbered from 1 to 6. If the cube is rolled once, which outcome is *least* likely to occur?
- 1) rolling an odd number
 - 2) rolling an even number
 - 3) rolling a number less than 6
 - 4) rolling a number greater than 4

- 319 If the speed of sound is 344 meters per second, what is the approximate speed of sound, in meters per hour?

60 seconds = 1 minute
60 minutes = 1 hour

- 1) 20,640
 - 2) 41,280
 - 3) 123,840
 - 4) 1,238,400
- 320 Solve the following system of equations algebraically:
- $$3x + 2y = 4$$
- $$4x + 3y = 7$$
- [Only an algebraic solution can receive full credit.]
- 321 A school wants to add a coed soccer program. To determine student interest in the program, a survey will be taken. In order to get an unbiased sample, which group should the school survey?
- 1) every third student entering the building
 - 2) every member of the varsity football team
 - 3) every member in Ms. Zimmer's drama classes
 - 4) every student having a second-period French class

- 322 Mrs. Ayer is painting the outside of her son's toy box, including the top and bottom. The toy box measures 3 feet long, 1.5 feet wide, and 2 feet high. What is the total surface area she will paint?
- 1) 9.0 ft^2
 - 2) 13.5 ft^2
 - 3) 22.5 ft^2
 - 4) 27.0 ft^2

- 323 Consider the graph of the equation $y = ax^2 + bx + c$, when $a \neq 0$. If a is multiplied by 3, what is true of the graph of the resulting parabola?
- 1) The vertex is 3 units above the vertex of the original parabola.
 - 2) The new parabola is 3 units to the right of the original parabola.
 - 3) The new parabola is wider than the original parabola.
 - 4) The new parabola is narrower than the original parabola.

324 Solve for x : $\frac{x+1}{x} = \frac{-7}{x-12}$

- 325 What is the product of 8.4×10^8 and 4.2×10^3 written in scientific notation?
- 1) 2.0×10^5
 - 2) 12.6×10^{11}
 - 3) 35.28×10^{11}
 - 4) 3.528×10^{12}

326 The equations $5x + 2y = 48$ and $3x + 2y = 32$ represent the money collected from school concert ticket sales during two class periods. If x represents the cost for each adult ticket and y represents the cost for each student ticket, what is the cost for each adult ticket?

- 1) \$20
- 2) \$10
- 3) \$8
- 4) \$4

327 Which value of x is the solution of the equation

$$\frac{2x}{3} + \frac{x}{6} = 5?$$

- 1) 6
- 2) 10
- 3) 15
- 4) 30

328 Marie currently has a collection of 58 stamps. If she buys s stamps each week for w weeks, which expression represents the total number of stamps she will have?

- 1) $58sw$
- 2) $58 + sw$
- 3) $58s + w$
- 4) $58 + s + w$

329 Factored, the expression $16x^2 - 25y^2$ is equivalent to

- 1) $(4x - 5y)(4x + 5y)$
- 2) $(4x - 5y)(4x - 5y)$
- 3) $(8x - 5y)(8x + 5y)$
- 4) $(8x - 5y)(8x - 5y)$

330 The spinner below is divided into eight equal regions and is spun once. What is the probability of *not* getting red?

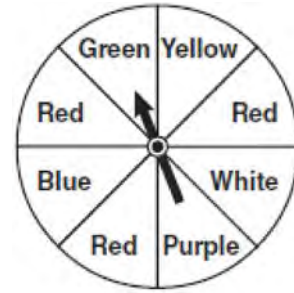

- 1) $\frac{3}{5}$
- 2) $\frac{3}{8}$
- 3) $\frac{5}{8}$
- 4) $\frac{7}{8}$

331 Which value of p is the solution of $5p - 1 = 2p + 20$?

- 1) $\frac{19}{7}$
- 2) $\frac{19}{3}$
- 3) 3
- 4) 7

332 The length of the hypotenuse of a right triangle is 34 inches and the length of one of its legs is 16 inches. What is the length, in inches, of the other leg of this right triangle?

- 1) 16
- 2) 18
- 3) 25
- 4) 30

- 333 Which ordered pair is in the solution set of the system of equations $y = -x + 1$ and $y = x^2 + 5x + 6$?
- 1) $(-5, -1)$
 - 2) $(-5, 6)$
 - 3) $(5, -4)$
 - 4) $(5, 2)$

- 334 Cassandra bought an antique dresser for \$500. If the value of her dresser increases 6% annually, what will be the value of Cassandra's dresser at the end of 3 years to the *nearest dollar*?
- 1) \$415
 - 2) \$590
 - 3) \$596
 - 4) \$770

- 335 When $4x^2 + 7x - 5$ is subtracted from $9x^2 - 2x + 3$, the result is
- 1) $5x^2 + 5x - 2$
 - 2) $5x^2 - 9x + 8$
 - 3) $-5x^2 + 5x - 2$
 - 4) $-5x^2 + 9x - 8$

- 336 Students in a ninth grade class measured their heights, h , in centimeters. The height of the shortest student was 155 cm, and the height of the tallest student was 190 cm. Which inequality represents the range of heights?
- 1) $155 < h < 190$
 - 2) $155 \leq h \leq 190$
 - 3) $h \geq 155$ or $h \leq 190$
 - 4) $h > 155$ or $h < 190$

- 337 Which equation most closely represents the line of best fit for the scatter plot below?



- 1) $y = x$
- 2) $y = \frac{2}{3}x + 1$
- 3) $y = \frac{3}{2}x + 4$
- 4) $y = \frac{3}{2}x + 1$

- 338 Solve for x : $\frac{3}{5}(x + 2) = x - 4$
- 1) 8
 - 2) 13
 - 3) 15
 - 4) 23

339 Which equation is represented by the graph below?

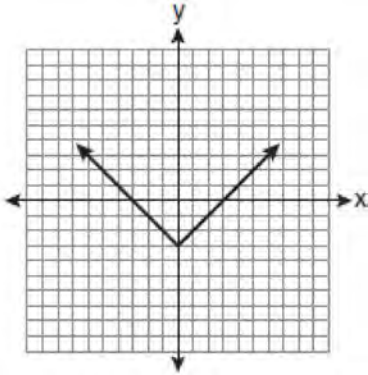

- 1) $y = x^2 - 3$
- 2) $y = (x - 3)^2$
- 3) $y = |x| - 3$
- 4) $y = |x - 3|$

340 What is the additive inverse of the expression $a - b$?

- 1) $a + b$
- 2) $a - b$
- 3) $-a + b$
- 4) $-a - b$

341 Given:

$$\text{Set } A = \{(-2, -1), (-1, 0), (1, 8)\}$$

$$\text{Set } B = \{(-3, -4), (-2, -1), (-1, 2), (1, 8)\}$$

What is the intersection of sets A and B ?

- 1) $\{(1, 8)\}$
- 2) $\{(-2, -1)\}$
- 3) $\{(-2, -1), (1, 8)\}$
- 4) $\{(-3, -4), (-2, -1), (-1, 2), (-1, 0), (1, 8)\}$

342 The table below shows the number of prom tickets sold over a ten-day period.

Prom Ticket Sales

Day (x)	1	2	5	7	10
Number of Prom Tickets Sold (y)	30	35	55	60	70

Plot these data points on the coordinate grid below. Use a consistent and appropriate scale. Draw a reasonable line of best fit and write its equation.

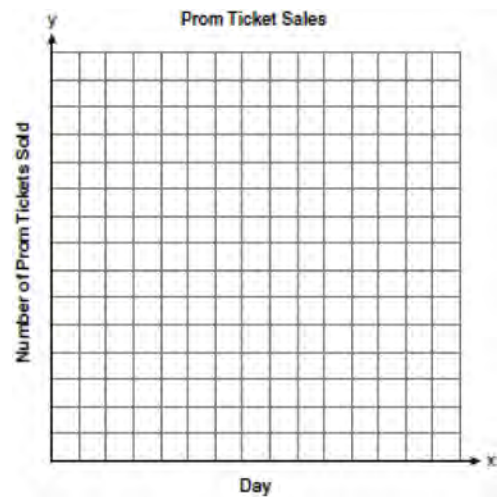

343 Mr. Laub has three children: two girls (Sue and Karen) and one boy (David). After each meal, one child is chosen at random to wash dishes. If the same child can be chosen for both lunch and dinner, construct a tree diagram or list a sample space of all the possible outcomes of who will wash dishes after lunch and dinner on Saturday. Determine the probability that one boy and one girl will wash dishes after lunch and dinner on Saturday.

- 344 Which expression is equivalent to $9x^2 - 16$?
- 1) $(3x + 4)(3x - 4)$
 - 2) $(3x - 4)(3x - 4)$
 - 3) $(3x + 8)(3x - 8)$
 - 4) $(3x - 8)(3x - 8)$
- 345 Which relationship can best be described as causal?
- 1) height and intelligence
 - 2) shoe size and running speed
 - 3) number of correct answers on a test and test score
 - 4) number of students in a class and number of students with brown hair

- 346 It takes Tammy 45 minutes to ride her bike 5 miles. At this rate, how long will it take her to ride 8 miles?
- 1) 0.89 hour
 - 2) 1.125 hours
 - 3) 48 minutes
 - 4) 72 minutes

- 347 What is the speed, in meters per second, of a paper airplane that flies 24 meters in 6 seconds?
- 1) 144
 - 2) 30
 - 3) 18
 - 4) 4

- 348 Which value of x is a solution of $\frac{5}{x} = \frac{x+13}{6}$?
- 1) -2
 - 2) -3
 - 3) -10
 - 4) -15

- 349 The set $\{11, 12\}$ is equivalent to
- 1) $\{x | 11 < x < 12, \text{ where } x \text{ is an integer}\}$
 - 2) $\{x | 11 < x \leq 12, \text{ where } x \text{ is an integer}\}$
 - 3) $\{x | 10 \leq x < 12, \text{ where } x \text{ is an integer}\}$
 - 4) $\{x | 10 < x \leq 12, \text{ where } x \text{ is an integer}\}$

- 350 On the set of axes below, solve the following system of equations graphically and state the coordinates of all points in the solution set.

$$y = x^2 + 4x - 5$$
$$y = x - 1$$

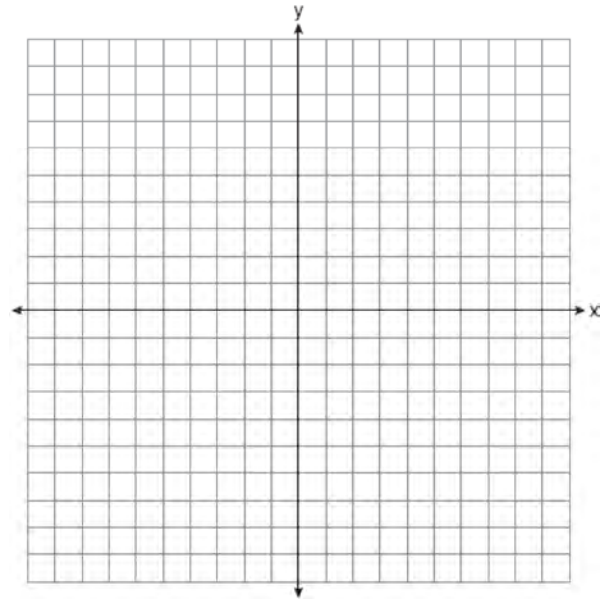

- 351 Which equation represents a line parallel to the x -axis?
- 1) $y = -5$
 - 2) $y = -5x$
 - 3) $x = 3$
 - 4) $x = 3y$

352 What is the value of the third quartile shown on the box-and-whisker plot below?

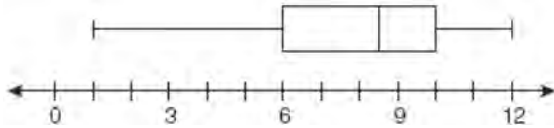

- 1) 6
- 2) 8.5
- 3) 10
- 4) 12

353 At the end of week one, a stock had increased in value from \$5.75 a share to \$7.50 a share. Find the percent of increase at the end of week one to the *nearest tenth of a percent*. At the end of week two, the same stock had decreased in value from \$7.50 to \$5.75. Is the percent of decrease at the end of week two the same as the percent of increase at the end of week one? Justify your answer.

354 In the right triangle shown in the diagram below, what is the value of x to the *nearest whole number*?

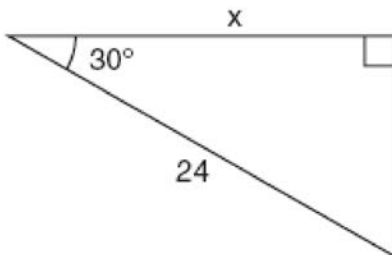

- 1) 12
- 2) 14
- 3) 21
- 4) 28

355 Which statement is true about the relation shown on the graph below?

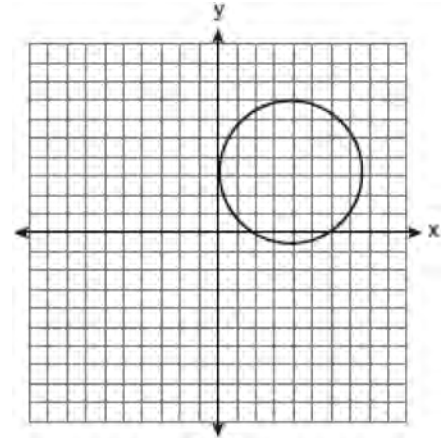

- 1) It is a function because there exists one x -coordinate for each y -coordinate.
- 2) It is a function because there exists one y -coordinate for each x -coordinate.
- 3) It is *not* a function because there are multiple y -values for a given x -value.
- 4) It is *not* a function because there are multiple x -values for a given y -value.

356 The test scores from Mrs. Gray's math class are shown below.

72, 73, 66, 71, 82, 85, 95, 85, 86, 89, 91, 92
 Construct a box-and-whisker plot to display these data.

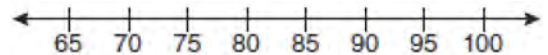

- 357 The table below represents the number of hours a student worked and the amount of money the student earned.

Number of Hours (h)	Dollars Earned (d)
8	\$50.00
15	\$93.75
19	\$118.75
30	\$187.50

Write an equation that represents the number of dollars, d , earned in terms of the number of hours, h , worked. Using this equation, determine the number of dollars the student would earn for working 40 hours.

358 Simplify: $\frac{27k^5m^8}{(4k^3)(9m^2)}$

- 359 What is the sum of $\frac{3}{2x}$ and $\frac{4}{3x}$ expressed in simplest form?

- 1) $\frac{12}{6x^2}$
- 2) $\frac{17}{6x}$
- 3) $\frac{7}{5x}$
- 4) $\frac{17}{12x}$

- 360 What are the roots of the equation $x^2 - 7x + 6 = 0$?
- 1) 1 and 7
 - 2) -1 and 7
 - 3) -1 and -6
 - 4) 1 and 6

- 361 Hannah took a trip to visit her cousin. She drove 120 miles to reach her cousin's house and the same distance back home. It took her 1.2 hours to get halfway to her cousin's house. What was her average speed, in miles per hour, for the first 1.2 hours of the trip? Hannah's average speed for the remainder of the trip to her cousin's house was 40 miles per hour. How long, in hours, did it take her to drive the remaining distance? Traveling home along the same route, Hannah drove at an average rate of 55 miles per hour. After 2 hours her car broke down. How many miles was she from home?

- 362 Brianna is using the two spinners shown below to play her new board game. She spins the arrow on each spinner once. Brianna uses the first spinner to determine how many spaces to move. She uses the second spinner to determine whether her move from the first spinner will be forward or backward.



Find the probability that Brianna will move *fewer than four spaces and backward*.

363 Which equation represents a line that is parallel to the line $y = 3 - 2x$?

- 1) $4x + 2y = 5$
- 2) $2x + 4y = 1$
- 3) $y = 3 - 4x$
- 4) $y = 4x - 2$

364 What is the slope of the line containing the points $(3, 4)$ and $(-6, 10)$?

- 1) $\frac{1}{2}$
- 2) 2
- 3) $-\frac{2}{3}$
- 4) $-\frac{3}{2}$

365 Mr. Turner bought x boxes of pencils. Each box holds 25 pencils. He left 3 boxes of pencils at home and took the rest to school. Which expression represents the total number of pencils he took to school?

- 1) $22x$
- 2) $25x - 3$
- 3) $25 - 3x$
- 4) $25x - 75$

366 What is the value of the expression $|-5x + 12|$ when $x = 5$?

- 1) -37
- 2) -13
- 3) 13
- 4) 37

367 Solve for g : $3 + 2g = 5g - 9$

368 On the set of axes below, draw the graph of $y = 2^x$ over the interval $-1 \leq x \leq 3$. Will this graph ever intersect the x -axis? Justify your answer.

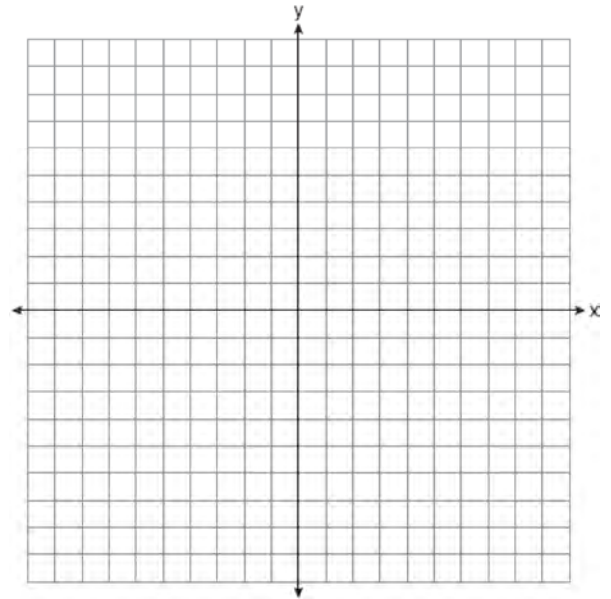

369 The diagram below represents Joe's two fish tanks.

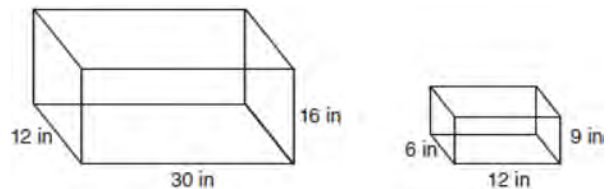

Joe's larger tank is completely filled with water. He takes water from it to completely fill the small tank. Determine how many cubic inches of water will remain in the larger tank.

370 Which graph represents the solution of $3y - 9 \leq 6x$?

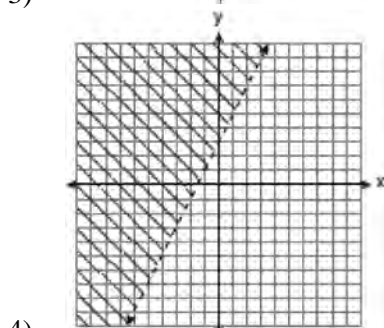
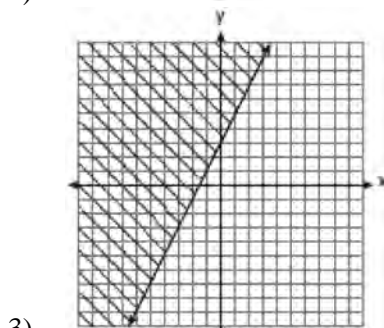
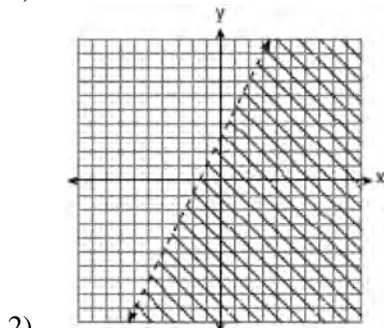
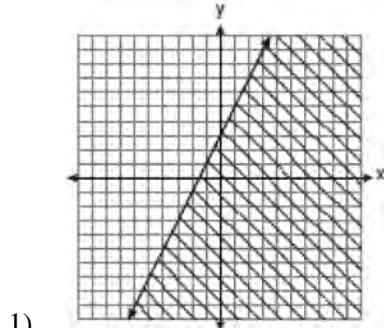

371 A soup can is in the shape of a cylinder. The can has a volume of 342 cm^3 and a diameter of 6 cm . Express the height of the can in terms of π . Determine the maximum number of soup cans that can be stacked on their base between two shelves if the distance between the shelves is exactly 36 cm . Explain your answer.

372 What is $\frac{6}{5x} - \frac{2}{3x}$ in simplest form?

- 1) $\frac{8}{15x^2}$
- 2) $\frac{8}{15x}$
- 3) $\frac{4}{15x}$
- 4) $\frac{4}{2x}$

373 The faces of a cube are numbered from 1 to 6. If the cube is tossed once, what is the probability that a prime number or a number divisible by 2 is obtained?

- 1) $\frac{6}{6}$
- 2) $\frac{5}{6}$
- 3) $\frac{4}{6}$
- 4) $\frac{1}{6}$

374 If $a + ar = b + r$, the value of a in terms of b and r can be expressed as

- 1) $\frac{b}{r} + 1$
- 2) $\frac{1+b}{r}$
- 3) $\frac{b+r}{1+r}$
- 4) $\frac{1+b}{r+b}$

375 Consider the set of integers greater than -2 and less than 6 . A subset of this set is the positive factors of 5 . What is the complement of this subset?

- 1) $\{0, 2, 3, 4\}$
- 2) $\{-1, 0, 2, 3, 4\}$
- 3) $\{-2, -1, 0, 2, 3, 4, 6\}$
- 4) $\{-2, -1, 0, 1, 2, 3, 4, 5, 6\}$

376 If $3ax + b = c$, then x equals

- 1) $c - b + 3a$
- 2) $c + b - 3a$
- 3) $\frac{c-b}{3a}$
- 4) $\frac{b-c}{3a}$

377 Jack bought 3 slices of cheese pizza and 4 slices of mushroom pizza for a total cost of \$12.50. Grace bought 3 slices of cheese pizza and 2 slices of mushroom pizza for a total cost of \$8.50. What is the cost of one slice of mushroom pizza?

- 1) \$1.50
- 2) \$2.00
- 3) \$3.00
- 4) \$3.50

378 Antwaan leaves a cup of hot chocolate on the counter in his kitchen. Which graph is the best representation of the change in temperature of his hot chocolate over time?

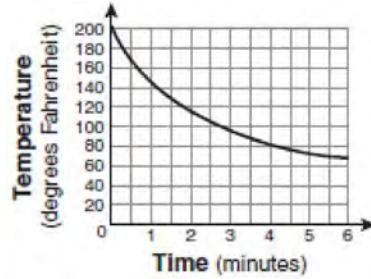

1)

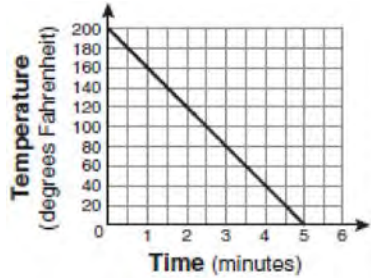

2)

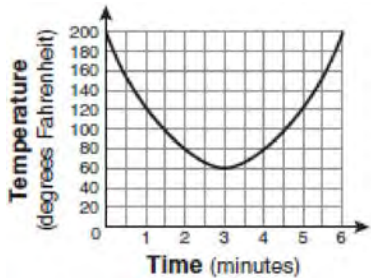

3)

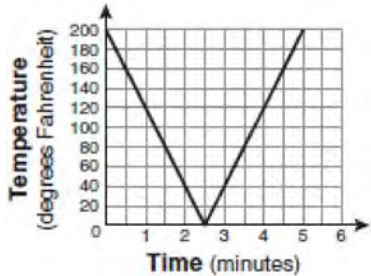

4)

379 Which verbal expression represents $2(n - 6)$?

- 1) two times n minus six
- 2) two times six minus n
- 3) two times the quantity n less than six
- 4) two times the quantity six less than n

380 The New York Volleyball Association invited 64 teams to compete in a tournament. After each round, half of the teams were eliminated. Which equation represents the number of teams, t , that remained in the tournament after r rounds?

- 1) $t = 64(r)^{0.5}$
- 2) $t = 64(-0.5)^r$
- 3) $t = 64(1.5)^r$
- 4) $t = 64(0.5)^r$

381 The chart below compares two runners.

Runner	Distance, in miles	Time, in hours
Greg	11	2
Dave	16	3

Based on the information in this chart, state which runner has the faster rate. Justify your answer.

382 Peter begins his kindergarten year able to spell 10 words. He is going to learn to spell 2 new words every day. Write an inequality that can be used to determine how many days, d , it takes Peter to be able to spell *at least* 75 words. Use this inequality to determine the minimum number of whole days it will take for him to be able to spell *at least* 75 words.

383 The expression $x^2 - 16$ is equivalent to

- 1) $(x + 2)(x - 8)$
- 2) $(x - 2)(x + 8)$
- 3) $(x + 4)(x - 4)$
- 4) $(x + 8)(x - 8)$

384 The box-and-whisker plot below represents students' scores on a recent English test.

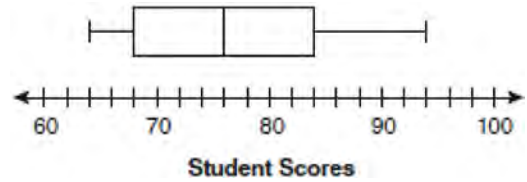

What is the value of the upper quartile?

- 1) 68
- 2) 76
- 3) 84
- 4) 94

385 Keisha is playing a game using a wheel divided into eight equal sectors, as shown in the diagram below. Each time the spinner lands on orange, she will win a prize.

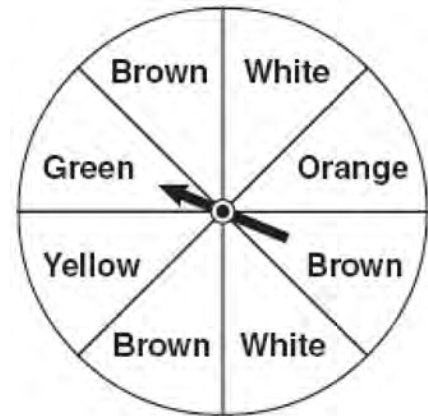

If Keisha spins this wheel twice, what is the probability she will win a prize on *both* spins?

- 1) $\frac{1}{64}$
- 2) $\frac{1}{56}$
- 3) $\frac{1}{16}$
- 4) $\frac{1}{4}$

386 The Fahrenheit temperature readings on 30 April mornings in Stormville, New York, are shown below.

41°, 58°, 61°, 54°, 49°, 46°, 52°, 58°, 67°, 43°,
 47°, 60°, 52°, 58°, 48°, 44°, 59°, 66°, 62°, 55°,
 44°, 49°, 62°, 61°, 59°, 54°, 57°, 58°, 63°, 60°

Using the data, complete the frequency table below.

Interval	Tally	Frequency
40–44		
45–49		
50–54		
55–59		
60–64		
65–69		

On the grid below, construct and label a frequency histogram based on the table.

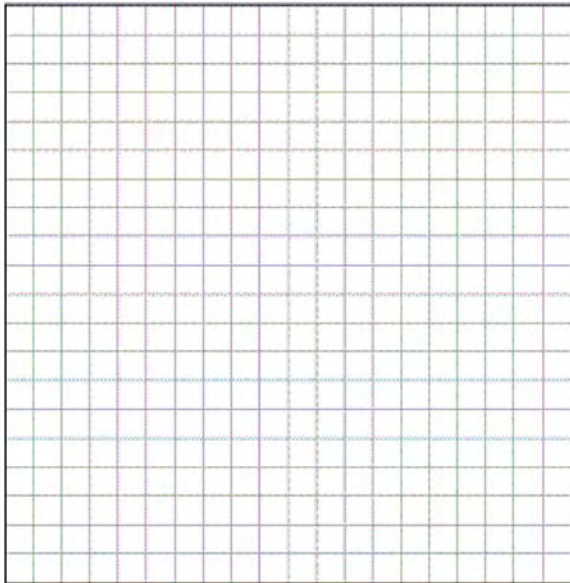

387 The data set 5, 6, 7, 8, 9, 9, 9, 10, 12, 14, 17, 17, 18, 19, 19 represents the number of hours spent on the Internet in a week by students in a mathematics class. Which box-and-whisker plot represents the data?

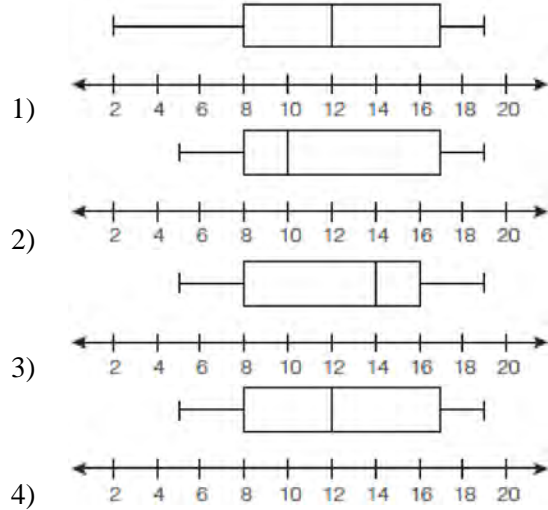

388 Sophie measured a piece of paper to be 21.7 cm by 28.5 cm. The piece of paper is actually 21.6 cm by 28.4 cm. Determine the number of square centimeters in the area of the piece of paper using Sophie’s measurements. Determine the number of square centimeters in the actual area of the piece of paper. Determine the relative error in calculating the area. Express your answer as a decimal to the nearest thousandth. Sophie does not think there is a significant amount of error. Do you agree or disagree? Justify your answer.

389 What are the roots of the equation

$$x^2 - 10x + 21 = 0?$$

- 1) 1 and 21
- 2) -5 and -5
- 3) 3 and 7
- 4) -3 and -7

- 390 The equation $y = -x^2 - 2x + 8$ is graphed on the set of axes below.

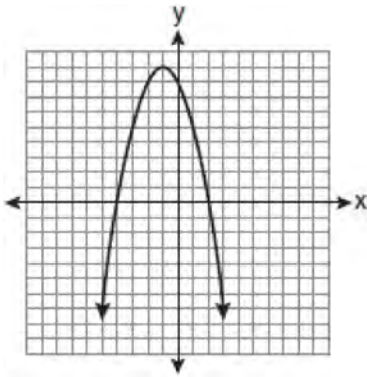

Based on this graph, what are the roots of the equation $-x^2 - 2x + 8 = 0$?

- 1) 8 and 0
 - 2) 2 and -4
 - 3) 9 and -1
 - 4) 4 and -2
- 391 What is an equation of the line that passes through the points (3, -3) and (-3, -3)?
- 1) $y = 3$
 - 2) $x = -3$
 - 3) $y = -3$
 - 4) $x = y$

- 392 What is the slope of the line that passes through the points (2, 5) and (7, 3)?
- 1) $-\frac{5}{2}$
 - 2) $-\frac{2}{5}$
 - 3) $\frac{8}{9}$
 - 4) $\frac{9}{8}$

- 393 The number of hours spent on math homework each week and the final exam grades for twelve students in Mr. Dylan's algebra class are plotted below.

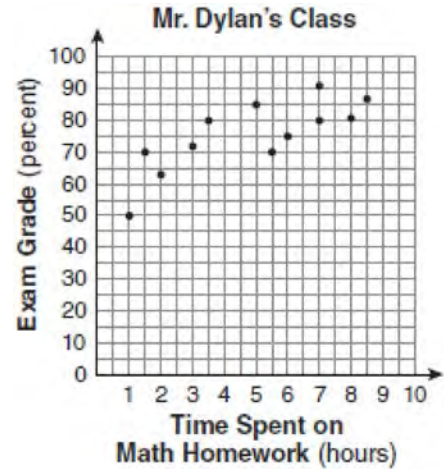

Based on a line of best fit, which exam grade is the best prediction for a student who spends about 4 hours on math homework each week?

- 1) 62
 - 2) 72
 - 3) 82
 - 4) 92
- 394 Which expression represents $\frac{25x - 125}{x^2 - 25}$ in simplest form?

- 1) $\frac{5}{x}$
- 2) $\frac{-5}{x}$
- 3) $\frac{25}{x - 5}$
- 4) $\frac{25}{x + 5}$

- 395 If h represents a number, which equation is a correct translation of "Sixty more than 9 times a number is 375"?
- 1) $9h = 375$
 - 2) $9h + 60 = 375$
 - 3) $9h - 60 = 375$
 - 4) $60h + 9 = 375$

- 396 Determine how many three-letter arrangements are possible with the letters $A, N, G, L,$ and E if no letter may be repeated.

- 397 In the diagram below, the circumference of circle O is 16π inches. The length of \overline{BC} is three-quarters of the length of diameter \overline{AD} and $CE = 4$ inches. Calculate the area, in square inches, of trapezoid $ABCD$.

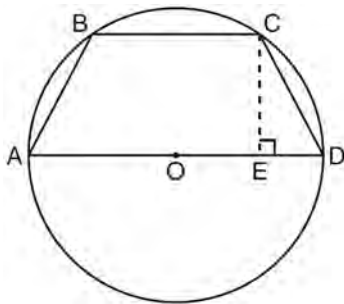

- 398 The expression $9x^2 - 100$ is equivalent to
- 1) $(9x - 10)(x + 10)$
 - 2) $(3x - 10)(3x + 10)$
 - 3) $(3x - 100)(3x - 1)$
 - 4) $(9x - 100)(x + 1)$

- 399 If the formula for the perimeter of a rectangle is $P = 2l + 2w$, then w can be expressed as

- 1) $w = \frac{2l - P}{2}$
- 2) $w = \frac{P - 2l}{2}$
- 3) $w = \frac{P - l}{2}$
- 4) $w = \frac{P - 2w}{2l}$

- 400 Which situation should be analyzed using bivariate data?

- 1) Ms. Saleem keeps a list of the amount of time her daughter spends on her social studies homework.
- 2) Mr. Benjamin tries to see if his students' shoe sizes are directly related to their heights.
- 3) Mr. DeStefan records his customers' best video game scores during the summer.
- 4) Mr. Chan keeps track of his daughter's algebra grades for the quarter.

- 401 The length of a rectangular window is 5 feet more than its width, w . The area of the window is 36 square feet. Which equation could be used to find the dimensions of the window?

- 1) $w^2 + 5w + 36 = 0$
- 2) $w^2 - 5w - 36 = 0$
- 3) $w^2 - 5w + 36 = 0$
- 4) $w^2 + 5w - 36 = 0$

402 The expression $\frac{9x^4 - 27x^6}{3x^3}$ is equivalent to

- 1) $3x(1 - 3x)$
- 2) $3x(1 - 3x^2)$
- 3) $3x(1 - 9x^5)$
- 4) $9x^3(1 - x)$

403 What is the product of $-3x^2y$ and $(5xy^2 + xy)$?

- 1) $-15x^3y^3 - 3x^3y^2$
- 2) $-15x^3y^3 - 3x^3y$
- 3) $-15x^2y^2 - 3x^2y$
- 4) $-15x^3y^3 + xy$

404 Students in Ms. Nazzeer's mathematics class tossed a six-sided number cube whose faces are numbered 1 to 6. The results are recorded in the table below.

Result	Frequency
1	3
2	6
3	4
4	6
5	4
6	7

Based on these data, what is the empirical probability of tossing a 4?

- 1) $\frac{8}{30}$
- 2) $\frac{6}{30}$
- 3) $\frac{5}{30}$
- 4) $\frac{1}{30}$

405 Which graph represents a linear function?

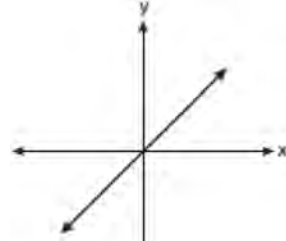

1)

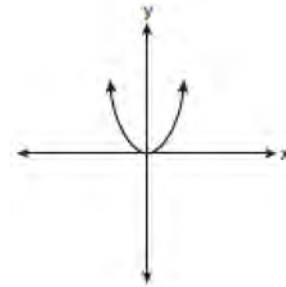

2)

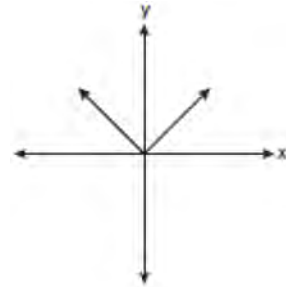

3)

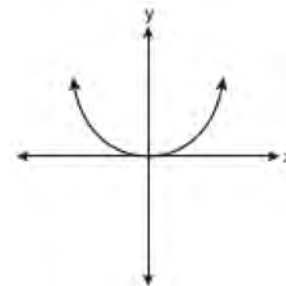

4)

406 What is $\sqrt{72}$ expressed in simplest radical form?

- 1) $2\sqrt{18}$
- 2) $3\sqrt{8}$
- 3) $6\sqrt{2}$
- 4) $8\sqrt{3}$

407 What is the product of $\frac{x^2 - 1}{x + 1}$ and $\frac{x + 3}{3x - 3}$ expressed in simplest form?

- 1) x
- 2) $\frac{x}{3}$
- 3) $x + 3$
- 4) $\frac{x + 3}{3}$

408 On the set of axes below, solve the following system of equations graphically for all values of x and y .

$$y = x^2 - 6x + 1$$

$$y + 2x = 6$$

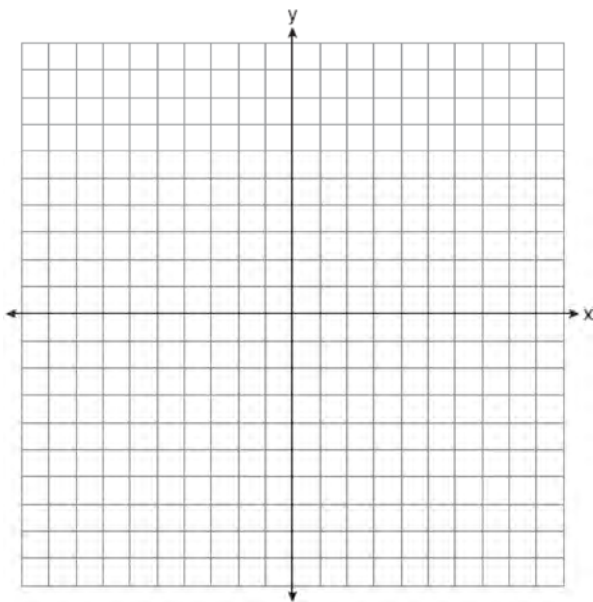

409 The diagram below shows the graph of $y = |x - 3|$.

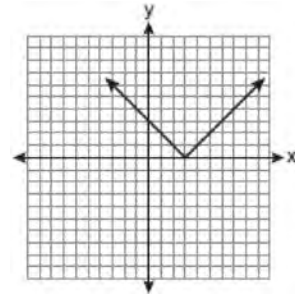

Which diagram shows the graph of $y = -|x - 3|$?

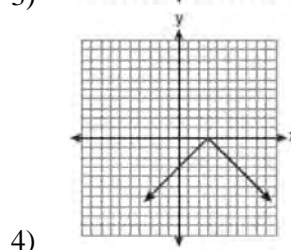
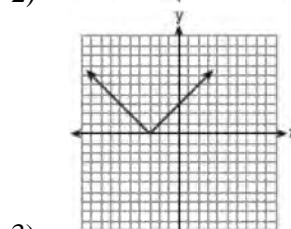
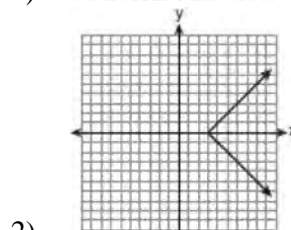
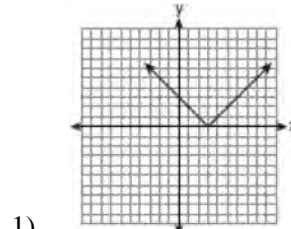

410 What is the product of 12 and 4.2×10^6 expressed in scientific notation?

- 1) 50.4×10^6
- 2) 50.4×10^7
- 3) 5.04×10^6
- 4) 5.04×10^7

411 Daniel's Print Shop purchased a new printer for \$35,000. Each year it depreciates (loses value) at a rate of 5%. What will its approximate value be at the end of the fourth year?

- 1) \$33,250.00
- 2) \$30,008.13
- 3) \$28,507.72
- 4) \$27,082.33

412 What is the value of x , in inches, in the right triangle below?

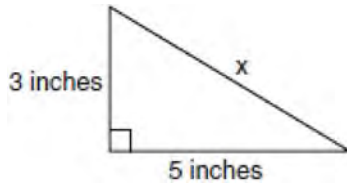

- 1) $\sqrt{15}$
- 2) 8
- 3) $\sqrt{34}$
- 4) 4

413 Lenny made a cube in technology class. Each edge measured 1.5 cm. What is the volume of the cube in cubic centimeters?

- 1) 2.25
- 2) 3.375
- 3) 9.0
- 4) 13.5

414 Which equation could be used to find the measure of one acute angle in the right triangle shown below?

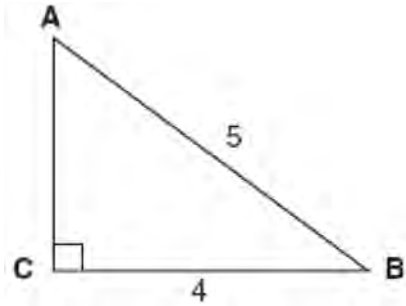

- 1) $\sin A = \frac{4}{5}$
- 2) $\tan A = \frac{5}{4}$
- 3) $\cos B = \frac{5}{4}$
- 4) $\tan B = \frac{4}{5}$

415 For which value of x is $\frac{x-3}{x^2-4}$ undefined?

- 1) -2
- 2) 0
- 3) 3
- 4) 4

416 A rectangle has an area of 24 square units. The width is 5 units less than the length. What is the length, in units, of the rectangle?

- 1) 6
- 2) 8
- 3) 3
- 4) 19

- 417 Solve the following systems of equations graphically, on the set of axes below, and state the coordinates of the point(s) in the solution set.

$$y = x^2 - 6x + 5$$

$$2x + y = 5$$

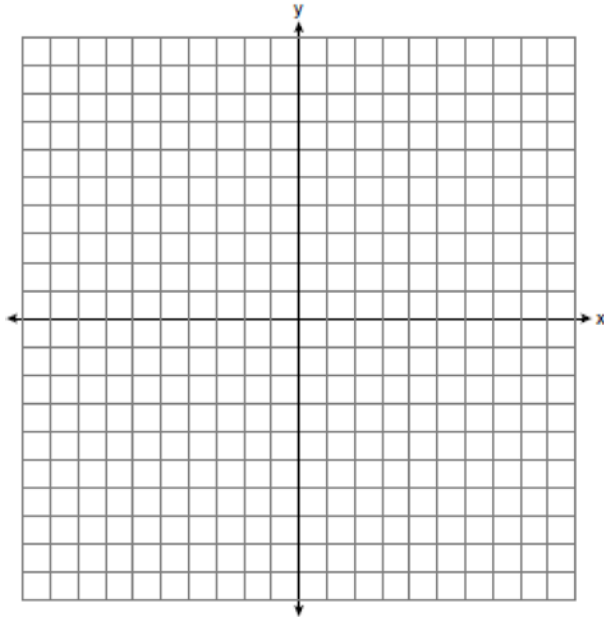

- 418 Throughout history, many people have contributed to the development of mathematics. These mathematicians include Pythagoras, Euclid, Hypatia, Euler, Einstein, Agnesi, Fibonacci, and Pascal. What is the probability that a mathematician's name selected at random from those listed will start with either the letter *E* or the letter *A*?

- 1) $\frac{2}{8}$
- 2) $\frac{3}{8}$
- 3) $\frac{4}{8}$
- 4) $\frac{6}{8}$

- 419 Which statement is true about the data set 3, 4, 5, 6, 7, 7, 10?

- 1) mean = mode
- 2) mean > mode
- 3) mean = median
- 4) mean < median

- 420 Given:

$$A = \{\text{All even integers from 2 to 20, inclusive}\}$$

$$B = \{10, 12, 14, 16, 18\}$$

What is the complement of set *B* within the universe of set *A*?

- 1) {4, 6, 8}
- 2) {2, 4, 6, 8}
- 3) {4, 6, 8, 20}
- 4) {2, 4, 6, 8, 20}

- 421 Serena's garden is a rectangle joined with a semicircle, as shown in the diagram below. Line segment *AB* is the diameter of semicircle *P*. Serena wants to put a fence around her garden.

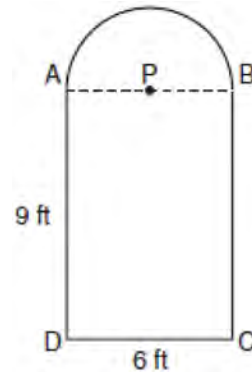

Calculate the length of fence Serena needs to the nearest tenth of a foot.

- 422 The prices of seven race cars sold last week are listed in the table below.

Price per Race Car	Number of Race Cars
\$126,000	1
\$140,000	2
\$180,000	1
\$400,000	2
\$819,000	1

What is the mean value of these race cars, in dollars? What is the median value of these race cars, in dollars? State which of these measures of central tendency best represents the value of the seven race cars. Justify your answer.

- 423 Nicole's aerobics class exercises to fast-paced music. If the rate of the music is 120 beats per minute, how many beats would there be in a class that is 0.75 hour long?
- 1) 90
 - 2) 160
 - 3) 5,400
 - 4) 7,200
- 424 What is half of 2^6 ?
- 1) 1^3
 - 2) 1^6
 - 3) 2^3
 - 4) 2^5

- 425 The table below shows a cumulative frequency distribution of runners' ages.

Cumulative Frequency Distribution of Runners' Ages

Age Group	Total
20-29	8
20-39	18
20-49	25
20-59	31
20-69	35

According to the table, how many runners are in their forties?

- 1) 25
 - 2) 10
 - 3) 7
 - 4) 6
- 426 The sum of two numbers is 47, and their difference is 15. What is the larger number?
- 1) 16
 - 2) 31
 - 3) 32
 - 4) 36
- 427 Which value of x is in the solution set of the inequality $-2x + 5 > 17$?
- 1) -8
 - 2) -6
 - 3) -4
 - 4) 12

- 428 To calculate the volume of a small wooden cube, Ezra measured an edge of the cube as 2 cm. The actual length of the edge of Ezra's cube is 2.1 cm. What is the relative error in his volume calculation to the *nearest hundredth*?
- 1) 0.13
 - 2) 0.14
 - 3) 0.15
 - 4) 0.16
- 429 The cost of 3 markers and 2 pencils is \$1.80. The cost of 4 markers and 6 pencils is \$2.90. What is the cost of *each* item? Include appropriate units in your answer.
- 430 John is going to line up his four golf trophies on a shelf in his bedroom. How many different possible arrangements can he make?
- 1) 24
 - 2) 16
 - 3) 10
 - 4) 4
- 431 The local ice cream stand offers three flavors of soft-serve ice cream: vanilla, chocolate, and strawberry; two types of cone: sugar and wafer; and three toppings: sprinkles, nuts, and cookie crumbs. If Dawn does not order vanilla ice cream, how many different choices can she make that have one flavor of ice cream, one type of cone, and one topping?
- 1) 7
 - 2) 8
 - 3) 12
 - 4) 18
- 432 Which expression represents $\frac{x^2 - 2x - 15}{x^2 + 3x}$ in simplest form?
- 1) -5
 - 2) $\frac{x-5}{x}$
 - 3) $\frac{-2x-5}{x}$
 - 4) $\frac{-2x-15}{3x}$
- 433 An online music club has a one-time registration fee of \$13.95 and charges \$0.49 to buy each song. If Emma has \$50.00 to join the club and buy songs, what is the maximum number of songs she can buy?
- 1) 73
 - 2) 74
 - 3) 130
 - 4) 131
- 434 The length of a rectangular room is 7 less than three times the width, w , of the room. Which expression represents the area of the room?
- 1) $3w - 4$
 - 2) $3w - 7$
 - 3) $3w^2 - 4w$
 - 4) $3w^2 - 7w$
- 435 Which value of x makes the expression $\frac{x+4}{x-3}$ undefined?
- 1) -4
 - 2) -3
 - 3) 3
 - 4) 0

- 436 A contractor needs 54 square feet of brick to construct a rectangular walkway. The length of the walkway is 15 feet more than the width. Write an equation that could be used to determine the dimensions of the walkway. Solve this equation to find the length and width, in feet, of the walkway.
- 437 Clayton has three fair coins. Find the probability that he gets two tails and one head when he flips the three coins.
- 438 Twelve players make up a high school basketball team. The team jerseys are numbered 1 through 12. The players wearing the jerseys numbered 3, 6, 7, 8, and 11 are the only players who start a game. Using set notation, list the complement of this subset.
- 439 Which value of x is in the solution set of the inequality $-4x + 2 > 10$?
- 1) -2
 - 2) 2
 - 3) 3
 - 4) -4
- 440 Some books are laid on a desk. Two are English, three are mathematics, one is French, and four are social studies. Theresa selects an English book and Isabelle then selects a social studies book. Both girls take their selections to the library to read. If Truman then selects a book at random, what is the probability that he selects an English book?
- 441 An electronics store sells DVD players and cordless telephones. The store makes a \$75 profit on the sale of each DVD player (d) and a \$30 profit on the sale of each cordless telephone (c). The store wants to make a profit of at least \$255.00 from its sales of DVD players and cordless phones. Which inequality describes this situation?
- 1) $75d + 30c < 255$
 - 2) $75d + 30c \leq 255$
 - 3) $75d + 30c > 255$
 - 4) $75d + 30c \geq 255$
- 442 On a certain day in Toronto, Canada, the temperature was 15° Celsius (C). Using the formula $F = \frac{9}{5}C + 32$, Peter converts this temperature to degrees Fahrenheit (F). Which temperature represents 15°C in degrees Fahrenheit?
- 1) -9
 - 2) 35
 - 3) 59
 - 4) 85
- 443 The ages of three brothers are consecutive even integers. Three times the age of the youngest brother exceeds the oldest brother's age by 48 years. What is the age of the youngest brother?
- 1) 14
 - 2) 18
 - 3) 22
 - 4) 26

- 444 What is the value of the y-coordinate of the solution to the system of equations $x - 2y = 1$ and $x + 4y = 7$?
- 1) 1
 - 2) -1
 - 3) 3
 - 4) 4

- 445 The equation $y = x^2 + 3x - 18$ is graphed on the set of axes below.

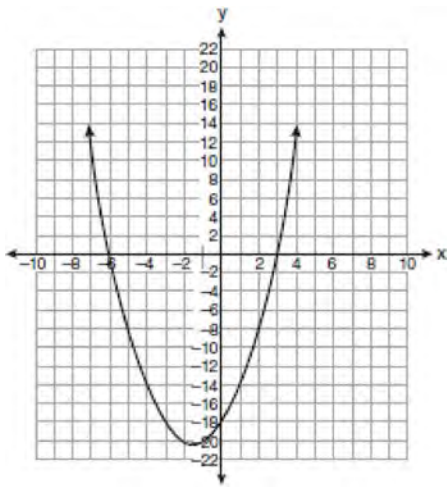

Based on this graph, what are the roots of the equation $x^2 + 3x - 18 = 0$?

- 1) -3 and 6
 - 2) 0 and -18
 - 3) 3 and -6
 - 4) 3 and -18
- 446 Which expression represents $(3x^2y^4)(4xy^2)$ in simplest form?
- 1) $12x^2y^8$
 - 2) $12x^2y^6$
 - 3) $12x^3y^8$
 - 4) $12x^3y^6$

- 447 Which value of x makes the expression

$$\frac{x^2 - 9}{x^2 + 7x + 10} \text{ undefined?}$$

- 1) -5
 - 2) 2
 - 3) 3
 - 4) -3
- 448 When $3g^2 - 4g + 2$ is subtracted from $7g^2 + 5g - 1$, the difference is
- 1) $-4g^2 - 9g + 3$
 - 2) $4g^2 + g + 1$
 - 3) $4g^2 + 9g - 3$
 - 4) $10g^2 + g + 1$
- 449 Which value of n makes the expression $\frac{5n}{2n - 1}$ undefined?
- 1) 1
 - 2) 0
 - 3) $-\frac{1}{2}$
 - 4) $\frac{1}{2}$
- 450 Which situation describes a correlation that is *not* a causal relationship?
- 1) The rooster crows, and the Sun rises.
 - 2) The more miles driven, the more gasoline needed
 - 3) The more powerful the microwave, the faster the food cooks.
 - 4) The faster the pace of a runner, the quicker the runner finishes.

- 451 A playground in a local community consists of a rectangle and two semicircles, as shown in the diagram below.

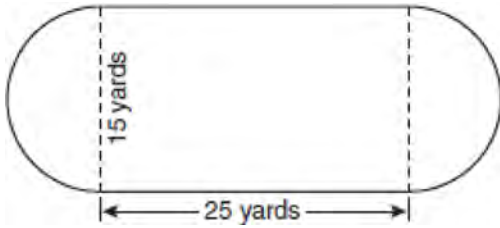

Which expression represents the amount of fencing, in yards, that would be needed to completely enclose the playground?

- 1) $15\pi + 50$
 - 2) $15\pi + 80$
 - 3) $30\pi + 50$
 - 4) $30\pi + 80$
- 452 A restaurant sells kids' meals consisting of one main course, one side dish, and one drink, as shown in the table below.

Kids' Meal Choices

Main Course	Side Dish	Drink
hamburger	French fries	milk
chicken nuggets	applesauce	juice
turkey sandwich		soda

Draw a tree diagram or list the sample space showing all possible kids' meals. How many different kids' meals can a person order? Jose does not drink juice. Determine the number of different kids' meals that do *not* include juice. Jose's sister will eat *only* chicken nuggets for her main course. Determine the number of different kids' meals that include chicken nuggets.

- 453 The bowling team at Lincoln High School must choose a president, vice president, and secretary. If the team has 10 members, which expression could be used to determine the number of ways the officers could be chosen?

- 1) ${}_3P_{10}$
- 2) ${}_7P_3$
- 3) ${}_{10}P_3$
- 4) ${}_{10}P_7$

- 454 What is $\frac{\sqrt{32}}{4}$ expressed in simplest radical form?

- 1) $\sqrt{2}$
- 2) $4\sqrt{2}$
- 3) $\sqrt{8}$
- 4) $\frac{\sqrt{8}}{2}$

- 455 A tree casts a 25-foot shadow on a sunny day, as shown in the diagram below.

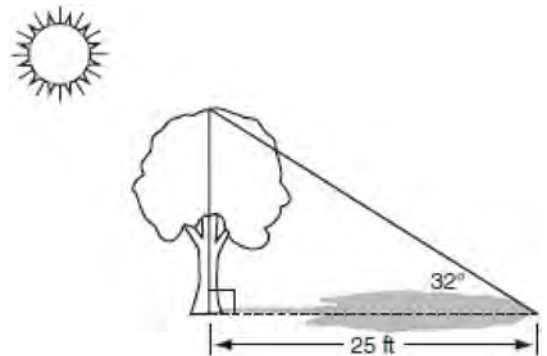

If the angle of elevation from the tip of the shadow to the top of the tree is 32° , what is the height of the tree to the nearest tenth of a foot?

- 1) 13.2
- 2) 15.6
- 3) 21.2
- 4) 40.0

- 456 On the set of axes below, graph the following system of inequalities and state the coordinates of a point in the solution set.

$$2x - y \geq 6$$

$$x > 2$$

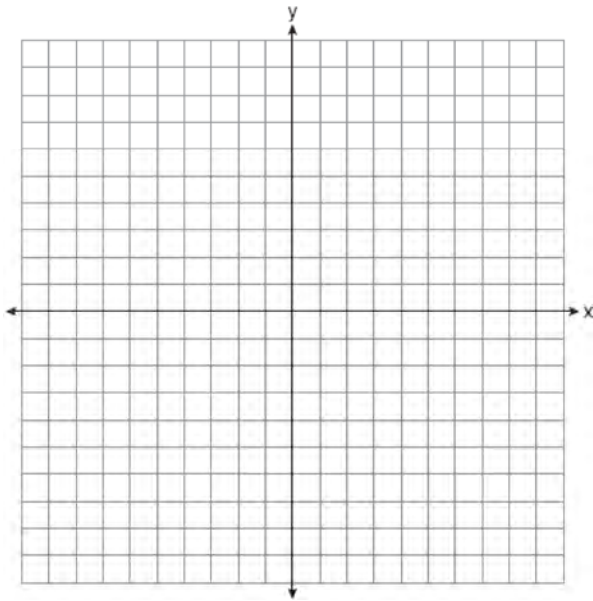

- 459 A swim team member performs a dive from a 14-foot-high springboard. The parabola below shows the path of her dive.

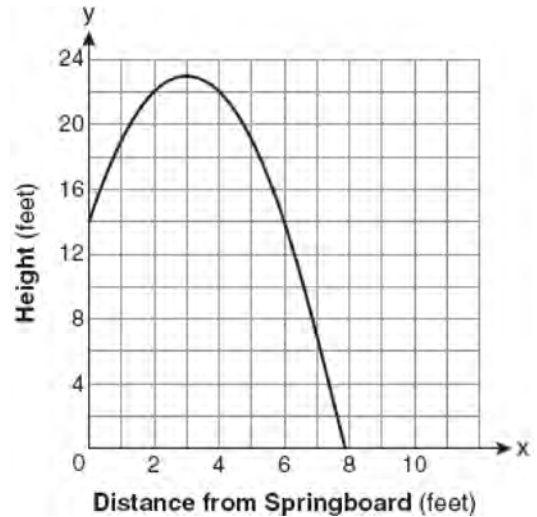

Which equation represents the axis of symmetry?

- 457 What are the vertex and axis of symmetry of the parabola $y = x^2 - 16x + 63$?

- 1) vertex: $(8, -1)$; axis of symmetry: $x = 8$
- 2) vertex: $(8, 1)$; axis of symmetry: $x = 8$
- 3) vertex: $(-8, -1)$; axis of symmetry: $x = -8$
- 4) vertex: $(-8, 1)$; axis of symmetry: $x = -8$

- 460 Which value of x is the solution of

$$\frac{2x}{5} + \frac{1}{3} = \frac{7x-2}{15}?$$

- 1) $\frac{3}{5}$
- 2) $\frac{31}{26}$
- 3) 3
- 4) 7

- 458 Which equation represents a line that is parallel to the line $y = -4x + 5$?

- 1) $y = -4x + 3$
- 2) $y = -\frac{1}{4}x + 5$
- 3) $y = \frac{1}{4}x + 3$
- 4) $y = 4x + 5$

461 A bank is advertising that new customers can open a savings account with a $3\frac{3}{4}\%$ interest rate compounded annually. Robert invests \$5,000 in an account at this rate. If he makes no additional deposits or withdrawals on his account, find the amount of money he will have, to the *nearest cent*, after three years.

462 The graph below illustrates the number of acres used for farming in Smalltown, New York, over several years.

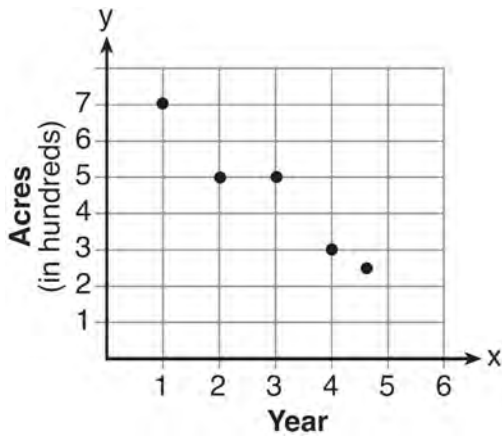

Using a line of best fit, approximately how many acres will be used for farming in the 5th year?

- 1) 0
- 2) 200
- 3) 300
- 4) 400

463 Which expression is equivalent to $(3x^2)^3$?

- 1) $9x^5$
- 2) $9x^6$
- 3) $27x^5$
- 4) $27x^6$

464 The gas tank in a car holds a total of 16 gallons of gas. The car travels 75 miles on 4 gallons of gas. If the gas tank is full at the beginning of a trip, which graph represents the rate of change in the amount of gas in the tank?

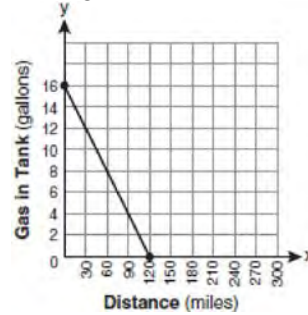

1)

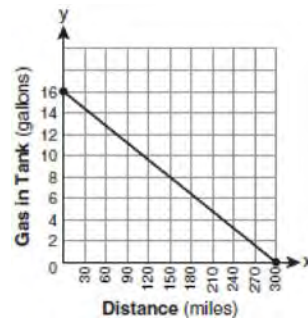

2)

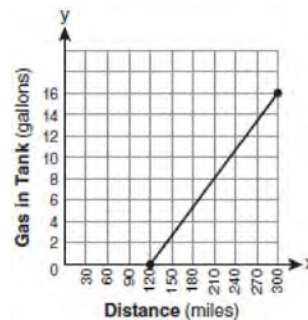

3)

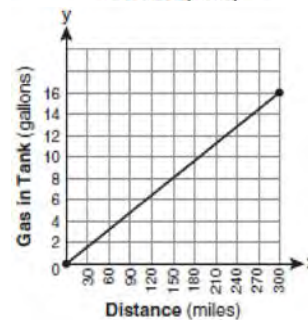

4)

- 465 What is the value of the y -coordinate of the solution to the system of equations $x + 2y = 9$ and $x - y = 3$?
- 1) 6
 - 2) 2
 - 3) 3
 - 4) 5
- 466 Which value of x is in the solution set of the inequality $-2(x - 5) < 4$?
- 1) 0
 - 2) 2
 - 3) 3
 - 4) 5
- 467 When $5\sqrt{20}$ is written in simplest radical form, the result is $k\sqrt{5}$. What is the value of k ?
- 1) 20
 - 2) 10
 - 3) 7
 - 4) 4
- 468 What is the product of $\frac{4x}{x-1}$ and $\frac{x^2-1}{3x+3}$ expressed in simplest form?
- 1) $\frac{4x}{3}$
 - 2) $\frac{4x^2}{3}$
 - 3) $\frac{4x^2}{3(x+1)}$
 - 4) $\frac{4(x+1)}{3}$
- 469 What is $\sqrt{32}$ expressed in simplest radical form?
- 1) $16\sqrt{2}$
 - 2) $4\sqrt{2}$
 - 3) $4\sqrt{8}$
 - 4) $2\sqrt{8}$
- 470 In triangle MCT , the measure of $\angle T = 90^\circ$, $MC = 85$ cm, $CT = 84$ cm, and $TM = 13$ cm. Which ratio represents the sine of $\angle C$?
- 1) $\frac{13}{85}$
 - 2) $\frac{84}{85}$
 - 3) $\frac{13}{84}$
 - 4) $\frac{84}{13}$
- 471 Tom drove 290 miles from his college to home and used 23.2 gallons of gasoline. His sister, Ann, drove 225 miles from her college to home and used 15 gallons of gasoline. Whose vehicle had better gas mileage? Justify your answer.
- 472 Which relation is *not* a function?
- 1) $\{(1, 5), (2, 6), (3, 6), (4, 7)\}$
 - 2) $\{(4, 7), (2, 1), (-3, 6), (3, 4)\}$
 - 3) $\{(-1, 6), (1, 3), (2, 5), (1, 7)\}$
 - 4) $\{(-1, 2), (0, 5), (5, 0), (2, -1)\}$
- 473 Solve algebraically for all values of x :
- $$\frac{3}{x+5} = \frac{2x}{x^2-8}$$

474 Which graph represents a function?

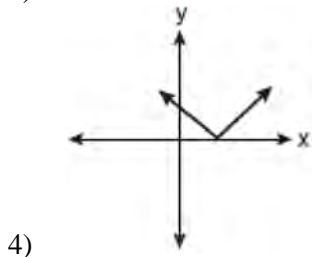
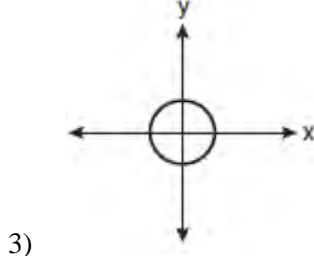
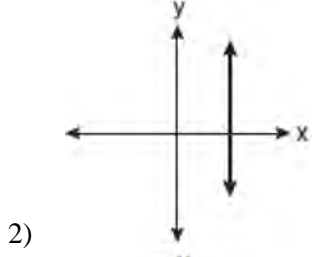
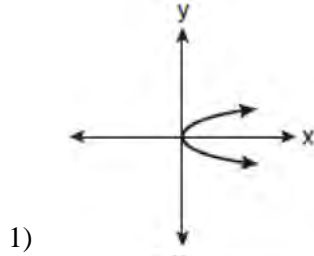

475 Tamara has a cell phone plan that charges \$0.07 per minute plus a monthly fee of \$19.00. She budgets \$29.50 per month for total cell phone expenses without taxes. What is the maximum number of minutes Tamara could use her phone each month in order to stay within her budget?

- 1) 150
- 2) 271
- 3) 421
- 4) 692

476 What are the vertex and the axis of symmetry of the parabola shown in the diagram below?

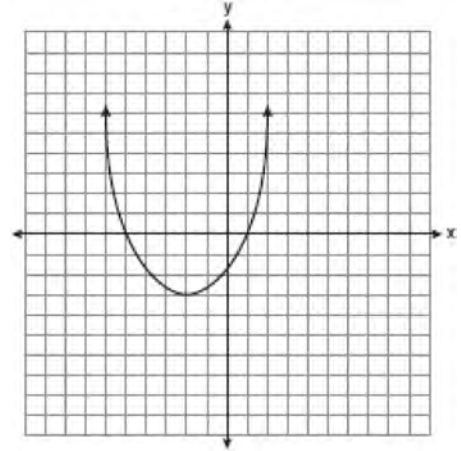

- 1) The vertex is $(-2, -3)$, and the axis of symmetry is $x = -2$.
- 2) The vertex is $(-2, -3)$, and the axis of symmetry is $y = -2$.
- 3) The vertex is $(-3, -2)$, and the axis of symmetry is $y = -2$.
- 4) The vertex is $(-3, -2)$, and the axis of symmetry is $x = -2$.

477 Sarah measures her rectangular bedroom window for a new shade. Her measurements are 36 inches by 42 inches. The actual measurements of the window are 36.5 inches and 42.5 inches. Using the measurements that Sarah took, determine the number of square inches in the area of the window. Determine the number of square inches in the actual area of the window. Determine the relative error in calculating the area. Express your answer as a decimal to the *nearest thousandth*.

- 478 Sam and Odel have been selling frozen pizzas for a class fundraiser. Sam has sold half as many pizzas as Odel. Together they have sold a total of 126 pizzas. How many pizzas did Sam sell?
- 1) 21
 - 2) 42
 - 3) 63
 - 4) 84

- 479 The center pole of a tent is 8 feet long, and a side of the tent is 12 feet long as shown in the diagram below.

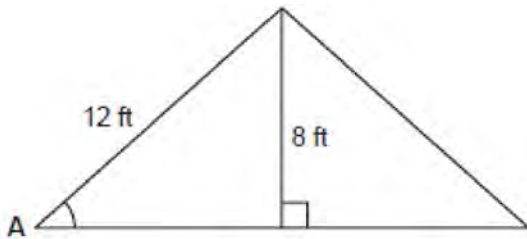

If a right angle is formed where the center pole meets the ground, what is the measure of angle A to the nearest degree?

- 1) 34
 - 2) 42
 - 3) 48
 - 4) 56
- 480 Which expression represents $\frac{27x^{18}y^5}{9x^6y}$ in simplest form?
- 1) $3x^{12}y^4$
 - 2) $3x^3y^5$
 - 3) $18x^{12}y^4$
 - 4) $18x^3y^5$

- 481 The diagram below shows right triangle UPC .

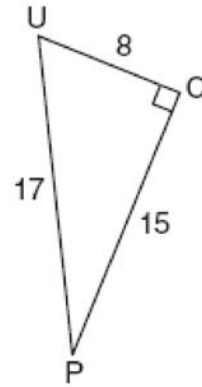

Which ratio represents the sine of $\angle U$?

- 1) $\frac{15}{8}$
 - 2) $\frac{15}{17}$
 - 3) $\frac{8}{15}$
 - 4) $\frac{8}{17}$
- 482 A survey is being conducted to determine which types of television programs people watch. Which survey and location combination would likely contain the most bias?
- 1) surveying 10 people who work in a sporting goods store
 - 2) surveying the first 25 people who enter a grocery store
 - 3) randomly surveying 50 people during the day in a mall
 - 4) randomly surveying 75 people during the day in a clothing store

- 483 A cylindrical container has a diameter of 12 inches and a height of 15 inches, as illustrated in the diagram below.

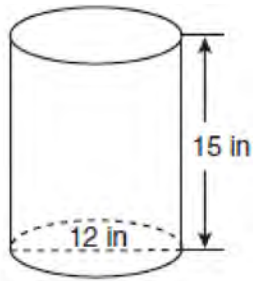

(Not drawn to scale)

What is the volume of this container to the *nearest tenth* of a cubic inch?

- 1) 6,785.8
 - 2) 4,241.2
 - 3) 2,160.0
 - 4) 1,696.5
- 484 Carrie bought new carpet for her living room. She calculated the area of the living room to be 174.2 square feet. The actual area was 149.6 square feet. What is the relative error of the area to the *nearest ten-thousandth*?
- 1) 0.1412
 - 2) 0.1644
 - 3) 1.8588
 - 4) 2.1644

- 485 The function $y = \frac{x}{x^2 - 9}$ is undefined when the

- value of x is
- 1) 0 or 3
 - 2) 3 or -3
 - 3) 3, only
 - 4) -3 , only

- 486 Kathy plans to purchase a car that depreciates (loses value) at a rate of 14% per year. The initial cost of the car is \$21,000. Which equation represents the value, v , of the car after 3 years?

- 1) $v = 21,000(0.14)^3$
- 2) $v = 21,000(0.86)^3$
- 3) $v = 21,000(1.14)^3$
- 4) $v = 21,000(0.86)(3)$

- 487 Express in simplest form: $\frac{2x^2 - 8x - 42}{6x^2} \div \frac{x^2 - 9}{x^2 - 3x}$

- 488 Luis is going to paint a basketball court on his driveway, as shown in the diagram below. This basketball court consists of a rectangle and a semicircle.

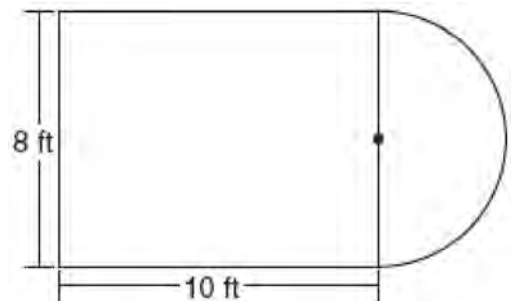

Which expression represents the area of this basketball court, in square feet?

- 1) 80
- 2) $80 + 8\pi$
- 3) $80 + 16\pi$
- 4) $80 + 64\pi$

489 What is the quotient of 8.05×10^6 and 3.5×10^2 ?

- 1) 2.3×10^3
- 2) 2.3×10^4
- 3) 2.3×10^8
- 4) 2.3×10^{12}

490 Perform the indicated operation and simplify:

$$\frac{3x+6}{4x+12} \div \frac{x^2-4}{x+3}$$

491 Twenty students were surveyed about the number of days they played outside in one week. The results of this survey are shown below.

{6,5,4,3,0,7,1,5,4,4,3,2,2,3,2,4,3,4,0,7}

Complete the frequency table below for these data.

Interval	Tally	Frequency
0-1		
2-3		
4-5		
6-7		

Complete the cumulative frequency table below using these data.

Number of Days Outside

Interval	Cumulative Frequency
0-1	
0-3	
0-5	
0-7	

On the grid below, create a cumulative frequency histogram based on the table you made.

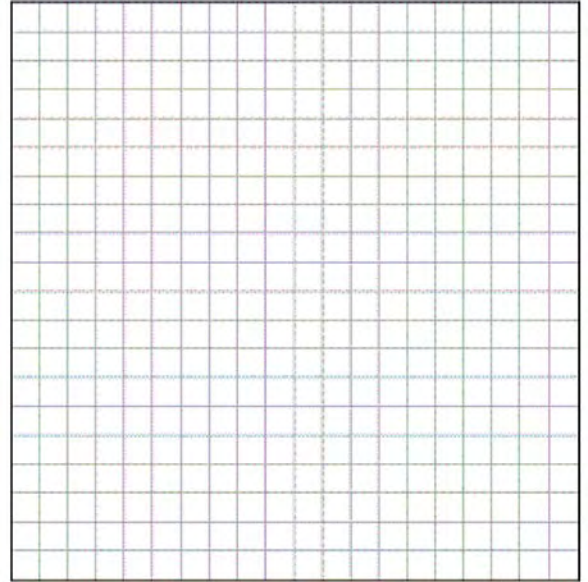

492 On the grid below, solve the system of equations graphically for x and y .

$$4x - 2y = 10$$

$$y = -2x - 1$$

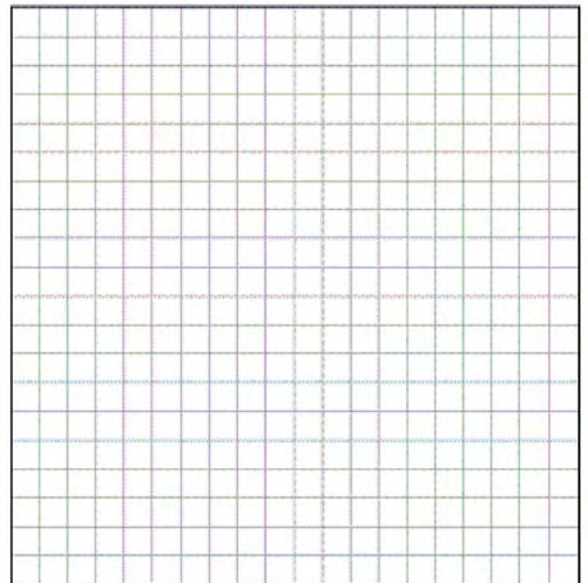

- 493 Graph the equation $y = x^2 - 2x - 3$ on the accompanying set of axes. Using the graph, determine the roots of the equation $x^2 - 2x - 3 = 0$.

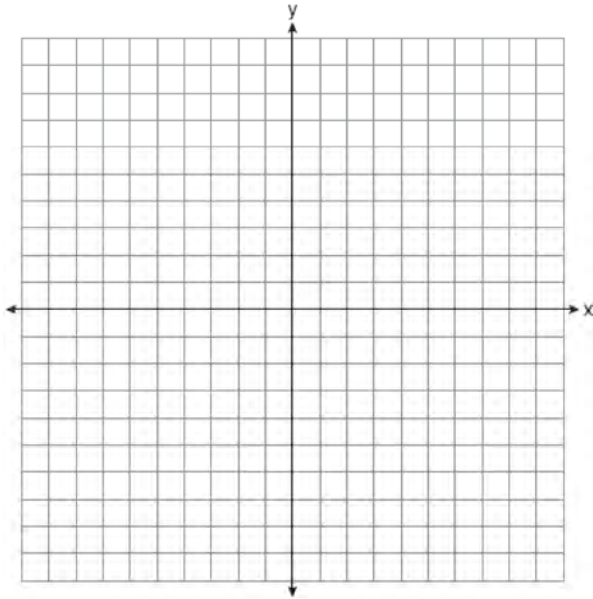

- 494 The values of 11 houses on Washington St. are shown in the table below.

Value per House	Number of Houses
\$100,000	1
\$175,000	5
\$200,000	4
\$700,000	1

Find the mean value of these houses in dollars.
 Find the median value of these houses in dollars.
 State which measure of central tendency, the mean or the median, *best* represents the values of these 11 houses. Justify your answer.

- 495 Factored completely, the expression $2x^2 + 10x - 12$ is equivalent to
- 1) $2(x - 6)(x + 1)$
 - 2) $2(x + 6)(x - 1)$
 - 3) $2(x + 2)(x + 3)$
 - 4) $2(x - 2)(x - 3)$

- 496 Express $5\sqrt{72}$ in simplest radical form.

- 497 Chad complained to his friend that he had five equations to solve for homework. Are all of the homework problems equations? Justify your answer.

Math Homework

1. $3x^2 \cdot 2x^4$
2. $5 - 2x = 3x$
3. $3(2x + 7)$
4. $7x^2 + 2x - 3x^2 - 9$
5. $\frac{2}{3} = \frac{x+2}{6}$

Name Chad

- 498 Find algebraically the equation of the axis of symmetry and the coordinates of the vertex of the parabola whose equation is $y = -2x^2 - 8x + 3$.

- 499 In the diagram of $\triangle ABC$ shown below, $BC = 10$ and $AB = 16$.

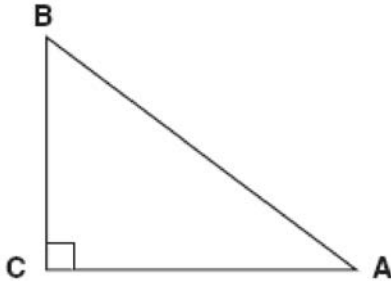

To the *nearest tenth of a degree*, what is the measure of the largest acute angle in the triangle?

- 1) 32.0
 - 2) 38.7
 - 3) 51.3
 - 4) 90.0
- 500 A stake is to be driven into the ground away from the base of a 50-foot pole, as shown in the diagram below. A wire from the stake on the ground to the top of the pole is to be installed at an angle of elevation of 52° .

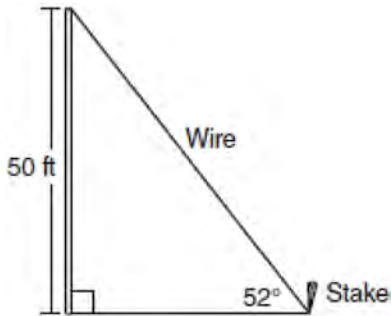

How far away from the base of the pole should the stake be driven in, to the *nearest foot*? What will be the length of the wire from the stake to the top of the pole, to the *nearest foot*?

- 501 A window is made up of a single piece of glass in the shape of a semicircle and a rectangle, as shown in the diagram below. Tess is decorating for a party and wants to put a string of lights all the way around the outside edge of the window.

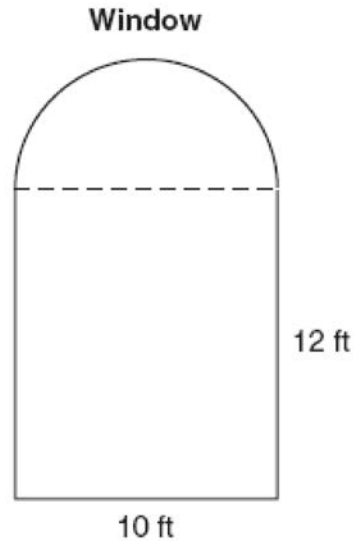

To the *nearest foot*, what is the length of the string of lights that Tess will need to decorate the window?

- 502 The set $\{1, 2, 3, 4\}$ is equivalent to
- 1) $\{x \mid 1 < x < 4, \text{ where } x \text{ is a whole number}\}$
 - 2) $\{x \mid 0 < x < 4, \text{ where } x \text{ is a whole number}\}$
 - 3) $\{x \mid 0 < x \leq 4, \text{ where } x \text{ is a whole number}\}$
 - 4) $\{x \mid 1 < x \leq 4, \text{ where } x \text{ is a whole number}\}$

- 503 In a game of ice hockey, the hockey puck took 0.8 second to travel 89 feet to the goal line. Determine the average speed of the puck in feet per second.

- 504 Ryan estimates the measurement of the volume of a popcorn container to be 282 cubic inches. The actual volume of the popcorn container is 289 cubic inches. What is the relative error of Ryan's measurement to the *nearest thousandth*?
- 1) 0.024
 - 2) 0.025
 - 3) 0.096
 - 4) 1.025

- 505 Which equation represents the axis of symmetry of the graph of the parabola below?

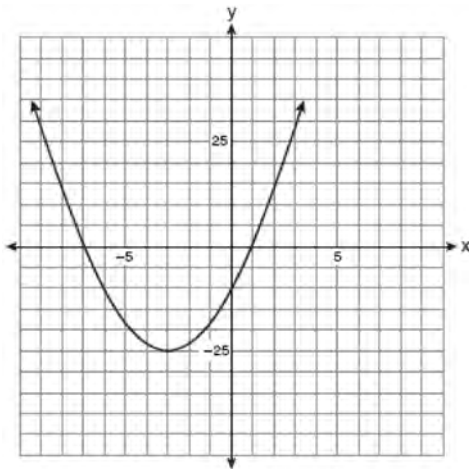

- 1) $y = -3$
 - 2) $x = -3$
 - 3) $y = -25$
 - 4) $x = -25$
- 506 Which value of x is in the solution set of $\frac{4}{3}x + 5 < 17$?
- 1) 8
 - 2) 9
 - 3) 12
 - 4) 16

- 507 At Genesee High School, the sophomore class has 60 more students than the freshman class. The junior class has 50 fewer students than twice the students in the freshman class. The senior class is three times as large as the freshman class. If there are a total of 1,424 students at Genesee High School, how many students are in the freshman class?
- 1) 202
 - 2) 205
 - 3) 235
 - 4) 236

- 508 In the diagram below, what is the slope of the line passing through points A and B?

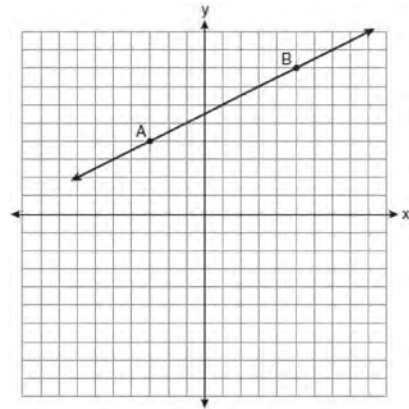

- 1) -2
- 2) 2
- 3) $-\frac{1}{2}$
- 4) $\frac{1}{2}$

Integrated Algebra Regents at Random

509 Which ordered pair is in the solution set of the system of inequalities shown in the graph below?

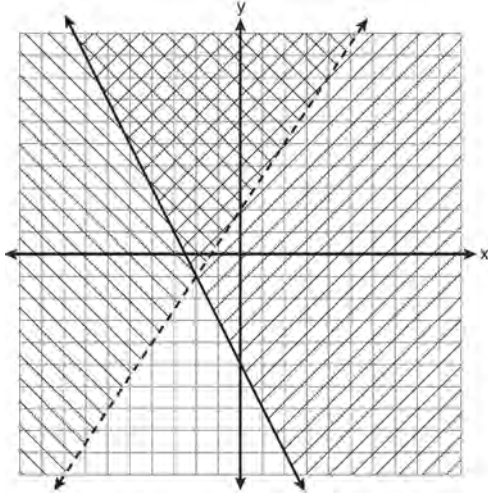

- 1) $(-2, -1)$
- 2) $(-2, 2)$
- 3) $(-2, -4)$
- 4) $(2, -2)$

510 What is the slope of the line that passes through the points $(3, 5)$ and $(-2, 2)$?

- 1) $\frac{1}{5}$
- 2) $\frac{3}{5}$
- 3) $\frac{5}{3}$
- 4) 5

511 Megan and Bryce opened a new store called the Donut Pit. Their goal is to reach a profit of \$20,000 in their 18th month of business. The table and scatter plot below represent the profit, P , in thousands of dollars, that they made during the first 12 months.

t (months)	P (profit, in thousands of dollars)
1	3.0
2	2.5
3	4.0
4	5.0
5	6.5
6	5.5
7	7.0
8	6.0
9	7.5
10	7.0
11	9.0
12	9.5

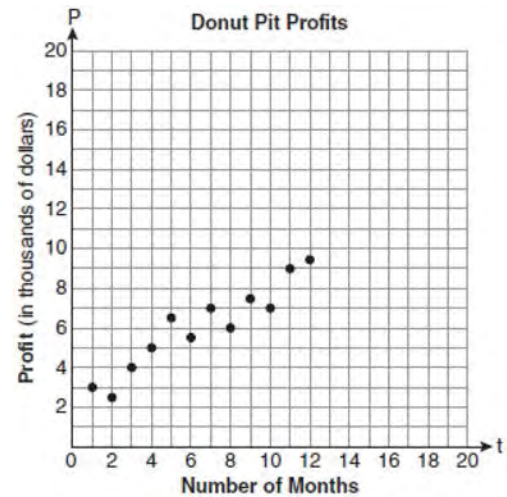

Draw a reasonable line of best fit. Using the line of best fit, predict whether Megan and Bryce will reach their goal in the 18th month of their business. Justify your answer.

- 512 A hot-air balloon is tied to the ground with two taut (straight) ropes, as shown in the diagram below. One rope is directly under the balloon and makes a right angle with the ground. The other rope forms an angle of 50° with the ground.

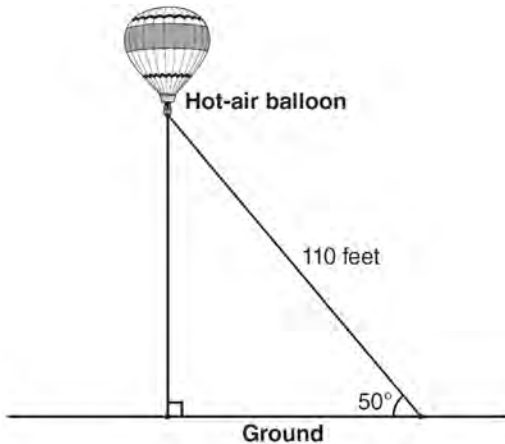

Determine the height, to the *nearest foot*, of the balloon directly above the ground. Determine the distance, to the *nearest foot*, on the ground between the two ropes.

- 513 The data in the table below are graphed, and the slope is examined.

x	y
0.5	9.0
1	8.75
1.5	8.5
2	8.25
2.5	8.0

The rate of change represented in this table can be described as

- 1) negative
- 2) positive
- 3) undefined
- 4) zero

- 514 The diagram below shows a cumulative frequency histogram of the students' test scores in Ms. Wedow's algebra class.

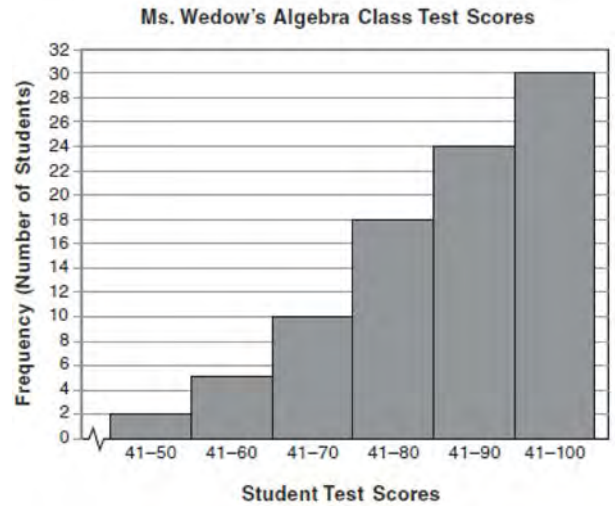

Determine the total number of students in the class. Determine how many students scored higher than 70. State which *ten-point interval* contains the median. State which *two ten-point intervals* contain the same frequency.

- 515 Find the volume, in cubic centimeters, *and* the surface area, in square centimeters, of the rectangular prism shown below.

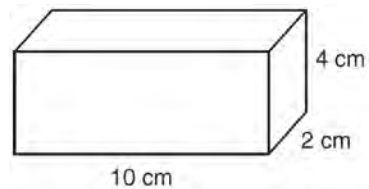

516 Which equation represents a quadratic function?

- 1) $y = x + 2$
- 2) $y = |x + 2|$
- 3) $y = x^2$
- 4) $y = 2^x$

517 The end of a dog's leash is attached to the top of a 5-foot-tall fence post, as shown in the diagram below. The dog is 7 feet away from the base of the fence post.

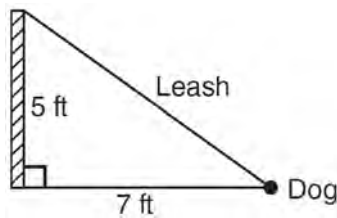

How long is the leash, to the *nearest tenth of a foot*?

- 1) 4.9
- 2) 8.6
- 3) 9.0
- 4) 12.0

518 What is the quotient of $\frac{x}{x+4}$ divided by $\frac{2x}{x^2-16}$?

- 1) $\frac{2}{x-4}$
- 2) $\frac{2x^2}{x-4}$
- 3) $\frac{2x^2}{x^2-16}$
- 4) $\frac{x-4}{2}$

519 What is the value of the expression $-3x^2y + 4x$ when $x = -4$ and $y = 2$?

- 1) -112
- 2) -80
- 3) 80
- 4) 272

520 For which set of values of x is the algebraic

expression $\frac{x^2 - 16}{x^2 - 4x - 12}$ undefined?

- 1) $\{-6, 2\}$
- 2) $\{-4, 3\}$
- 3) $\{-4, 4\}$
- 4) $\{-2, 6\}$

521 What is the equation of the axis of symmetry of the parabola shown in the diagram below?

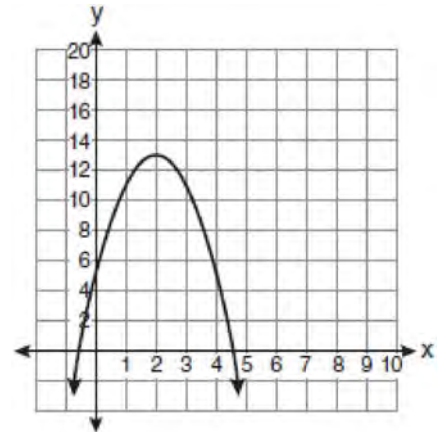

- 1) $x = -0.5$
- 2) $x = 2$
- 3) $x = 4.5$
- 4) $x = 13$

522 Which algebraic expression represents 15 less than x divided by 9?

- 1) $\frac{x}{9} - 15$
- 2) $9x - 15$
- 3) $15 - \frac{x}{9}$
- 4) $15 - 9x$

523 Which set of ordered pairs represents a function?

- 1) $\{(0, 4), (2, 4), (2, 5)\}$
- 2) $\{(6, 0), (5, 0), (4, 0)\}$
- 3) $\{(4, 1), (6, 2), (6, 3), (5, 0)\}$
- 4) $\{(0, 4), (1, 4), (0, 5), (1, 5)\}$

524 What is the slope of the line passing through the points A and B , as shown on the graph below?

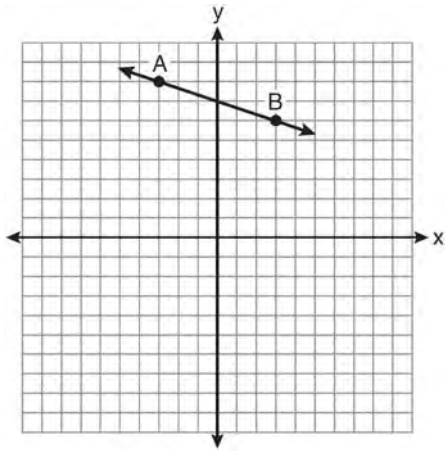

- 1) -3
- 2) $-\frac{1}{3}$
- 3) 3
- 4) $\frac{1}{3}$

525 The legs of an isosceles right triangle each measure 10 inches. What is the length of the hypotenuse of this triangle, to the *nearest tenth of an inch*?

- 1) 6.3
- 2) 7.1
- 3) 14.1
- 4) 17.1

526 If $\frac{ey}{n} + k = t$, what is y in terms of e , n , k , and t ?

- 1) $y = \frac{tn + k}{e}$
- 2) $y = \frac{tn - k}{e}$
- 3) $y = \frac{n(t + k)}{e}$
- 4) $y = \frac{n(t - k)}{e}$

527 The length of a rectangle is 3 inches more than its width. The area of the rectangle is 40 square inches. What is the length, in inches, of the rectangle?

- 1) 5
- 2) 8
- 3) 8.5
- 4) 11.5

528 The dimensions of a rectangle are measured to be 12.2 inches by 11.8 inches. The actual dimensions are 12.3 inches by 11.9 inches. What is the relative error, to the *nearest ten-thousandth*, in calculating the area of the rectangle?

- 1) 0.0168
- 2) 0.0167
- 3) 0.0165
- 4) 0.0164

- 529 In a recent town election, 1,860 people voted for either candidate *A* or candidate *B* for the position of supervisor. If candidate *A* received 55% of the votes, how many votes did candidate *B* receive?
- 1) 186
 - 2) 837
 - 3) 1,023
 - 4) 1,805

- 530 Which point lies on the line whose equation is $2x - 3y = 9$?
- 1) $(-1, -3)$
 - 2) $(-1, 3)$
 - 3) $(0, 3)$
 - 4) $(0, -3)$

- 531 As shown in the diagram below, a ladder 5 feet long leans against a wall and makes an angle of 65° with the ground. Find, to the *nearest tenth of a foot*, the distance from the wall to the base of the ladder.

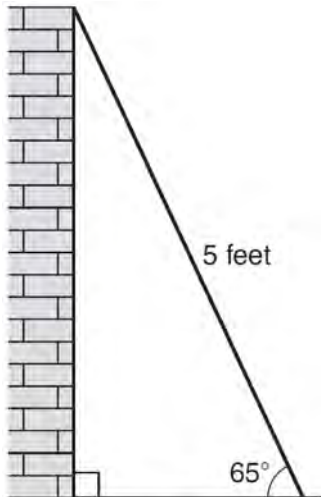

- 532 Four hundred licensed drivers participated in the math club's survey on driving habits. The table below shows the number of drivers surveyed in each age group.

Ages of People in Survey on Driving Habits

Age Group	Number of Drivers
16-25	150
26-35	129
36-45	33
46-55	57
56-65	31

Which statement best describes a conclusion based on the data in the table?

- 1) It may be biased because no one younger than 16 was surveyed.
- 2) It would be fair because many different age groups were surveyed.
- 3) It would be fair because the survey was conducted by the math club students.
- 4) It may be biased because the majority of drivers surveyed were in the younger age intervals.

- 533 What is the slope of the line passing through the points $(-2, 4)$ and $(3, 6)$?

- 1) $-\frac{5}{2}$
- 2) $-\frac{2}{5}$
- 3) $\frac{2}{5}$
- 4) $\frac{5}{2}$

534 Which ordered pair is in the solution set of the system of linear inequalities graphed below?

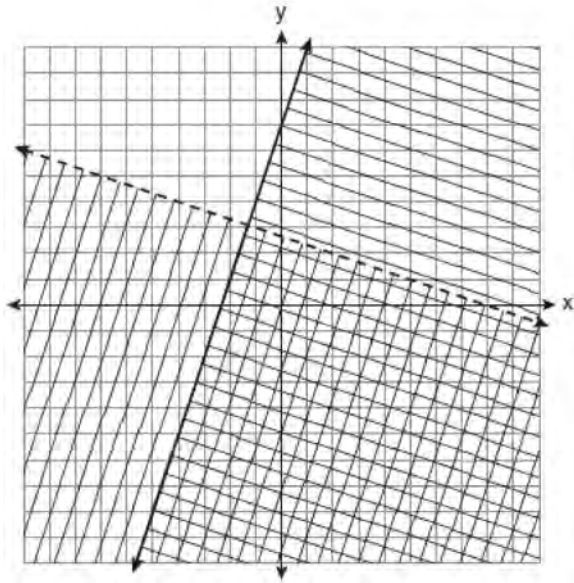

- 1) (1, -4)
- 2) (-5, 7)
- 3) (5, 3)
- 4) (-7, -2)

535 Ben has four more than twice as many CDs as Jake. If they have a total of 31 CDs, how many CDs does Jake have?

- 1) 9
- 2) 13
- 3) 14
- 4) 22

536 Express in simplest form:

$$\frac{x^2 + 9x + 14}{x^2 - 49} \div \frac{3x + 6}{x^2 + x - 56}$$

537 An example of an algebraic expression is

- 1) $\frac{2x + 3}{7} = \frac{13}{x}$
- 2) $(2x + 1)(x - 7)$
- 3) $4x - 1 = 4$
- 4) $x = 2$

538 An example of an algebraic expression is

- 1) $x + 2$
- 2) $y = x + 2$
- 3) $y < x + 2$
- 4) $y = x^2 + 2x$

539 A bag contains eight green marbles, five white marbles, and two red marbles. What is the probability of drawing a red marble from the bag?

- 1) $\frac{1}{15}$
- 2) $\frac{2}{15}$
- 3) $\frac{2}{13}$
- 4) $\frac{13}{15}$

540 What is the value of the expression $(a^3 + b^0)^2$ when $a = -2$ and $b = 4$?

- 1) 64
- 2) 49
- 3) -49
- 4) -64

- 541 On the set of axes below, solve the following system of equations graphically and state the coordinates of *all* points in the solution set.

$$y = -x^2 + 6x - 3$$

$$x + y = 7$$

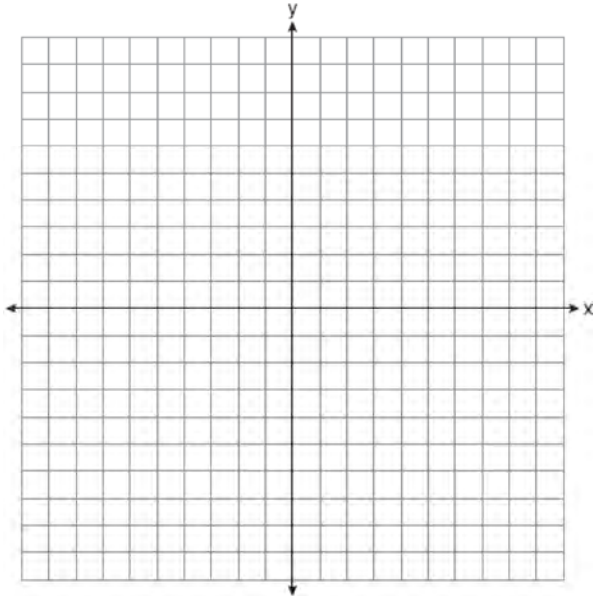

- 542 The value of the expression $-|a - b|$ when $a = 7$ and $b = -3$ is

- 1) -10
- 2) 10
- 3) -4
- 4) 4

- 543 Alexis calculates the surface area of a gift box as 600 square inches. The actual surface area of the gift box is 592 square inches. Find the relative error of Alexis' calculation expressed as a decimal to the *nearest thousandth*.

- 544 Three high school juniors, Reese, Matthew, and Chris, are running for student council president. A survey is taken a week before the election asking 40 students which candidate they will vote for in the election. The results are shown in the table below.

Candidate's Name	Number of Students Supporting Candidate
Reese	15
Matthew	13
Chris	12

Based on the table, what is the probability that a student will vote for Reese?

- 1) $\frac{1}{3}$
- 2) $\frac{3}{5}$
- 3) $\frac{3}{8}$
- 4) $\frac{5}{8}$

- 545 Which data set describes a situation that could be classified as quantitative?
- 1) the phone numbers in a telephone book
 - 2) the addresses for students at Hopkins High School
 - 3) the zip codes of residents in the city of Buffalo, New York
 - 4) the time it takes each of Mr. Harper's students to complete a test

- 546 This year, John played in 10 baseball games. In these games he had hit the ball 2, 3, 0, 1, 3, 2, 4, 0, 2, and 3 times. In the first 10 games he plays next year, John wants to increase his average (mean) hits per game by 0.5. What is the total number of hits John needs over the first 10 games next year to achieve his goal?
- 1) 5
 - 2) 2
 - 3) 20
 - 4) 25

- 547 The square dart board shown below has a side that measures 40 inches. The shaded portion in the center is a square whose side is 15 inches. A dart thrown at the board is equally likely to land on any point on the dartboard.

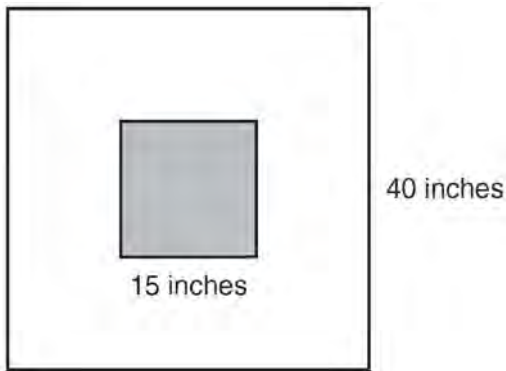

Find the probability that a dart hitting the board will *not* land in the shaded area.

- 548 The area of a rectangle is represented by $x^2 - 5x - 24$. If the width of the rectangle is represented by $x - 8$, express the length of the rectangle as a binomial.

- 549 The graph of the equation $y = |x|$ is shown in the diagram below.

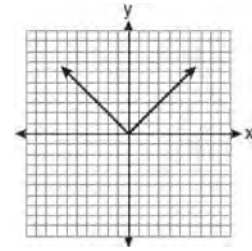

Which diagram could represent a graph of the equation $y = a|x|$ when $-1 < a < 0$?

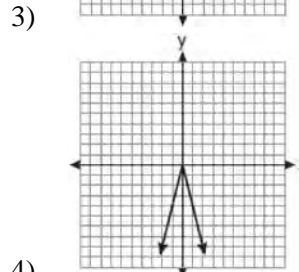
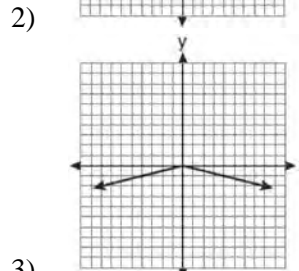
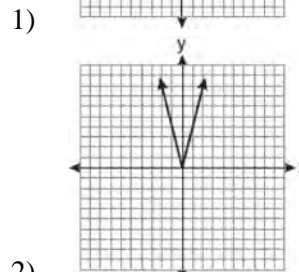
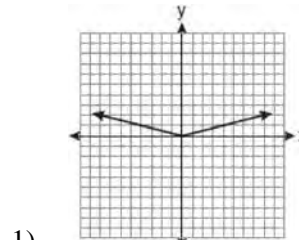

550 Michael is 25 years younger than his father. The sum of their ages is 53. What is Michael's age?

- 1) 14
- 2) 25
- 3) 28
- 4) 39

551 Which expression represents $36x^2 - 100y^6$ factored completely?

- 1) $2(9x + 25y^3)(9x - 25y^3)$
- 2) $4(3x + 5y^3)(3x - 5y^3)$
- 3) $(6x + 10y^3)(6x - 10y^3)$
- 4) $(18x + 50y^3)(18x - 50y^3)$

552 Given: $X = \{1, 2, 3, 4\}$

$$Y = \{2, 3, 4, 5\}$$

$$Z = \{3, 4, 5, 6\}$$

What is the intersection of sets X , Y , and Z ?

- 1) $\{3, 4\}$
- 2) $\{2, 3, 4\}$
- 3) $\{3, 4, 5\}$
- 4) $\{1, 2, 3, 4, 5, 6\}$

553 Which notation describes $\{1, 2, 3\}$?

- 1) $\{x | 1 \leq x < 3, \text{ where } x \text{ is an integer}\}$
- 2) $\{x | 0 < x \leq 3, \text{ where } x \text{ is an integer}\}$
- 3) $\{x | 1 < x < 3, \text{ where } x \text{ is an integer}\}$
- 4) $\{x | 0 \leq x \leq 3, \text{ where } x \text{ is an integer}\}$

554 Which is the graph of $y = |x| + 2$?

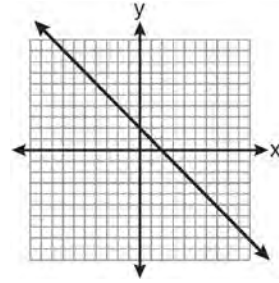

1)

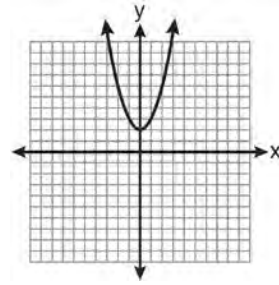

2)

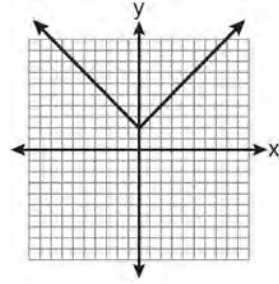

3)

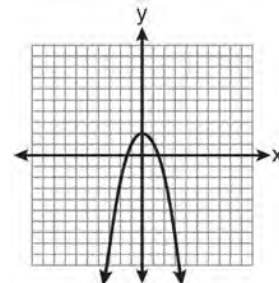

4)

555 In right triangle ABC , $AB = 20$, $AC = 12$, $BC = 16$, and $m\angle C = 90$. Find, to the nearest degree, the measure of $\angle A$.

- 556 Which set represents the intersection of sets A, B, and C shown in the diagram below?

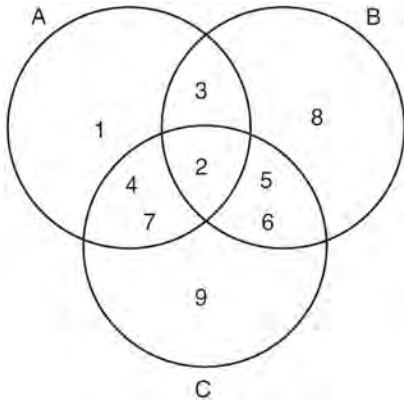

- 1) {3, 4, 5, 6, 7}
2) {2}
3) {2, 3, 4, 5, 6, 7}
4) {1, 2, 3, 4, 5, 6, 7, 8, 9}
- 557 What is the solution set of $\frac{x+2}{x-2} = \frac{-3}{x}$?

- 1) {-2, 3}
2) {-3, -2}
3) {-1, 6}
4) {-6, 1}

- 558 When $a^3 - 4a$ is factored completely, the result is

- 1) $(a-2)(a+2)$
2) $a(a-2)(a+2)$
3) $a^2(a-4)$
4) $a(a-2)^2$

- 559 Which equation illustrates the associative property?

- 1) $x + y + z = x + y + z$
2) $x(y + z) = xy + xz$
3) $x + y + z = z + y + x$
4) $(x + y) + z = x + (y + z)$

- 560 Jack wants to replace the flooring in his rectangular kitchen. He calculates the area of the floor to be 12.8 square meters. The actual area of the floor is 13.5 square meters. What is the relative error in calculating the area of the floor, to the nearest thousandth?

- 1) 0.051
2) 0.052
3) 0.054
4) 0.055

- 561 Given: $Q = \{0, 2, 4, 6\}$

$$W = \{0, 1, 2, 3\}$$

$$Z = \{1, 2, 3, 4\}$$

What is the intersection of sets Q, W, and Z?

- 1) {2}
2) {0, 2}
3) {1, 2, 3}
4) {0, 1, 2, 3, 4, 6}

- 562 Factored completely, the expression $3x^2 - 3x - 18$ is equivalent to

- 1) $3(x^2 - x - 6)$
2) $3(x-3)(x+2)$
3) $(3x-9)(x+2)$
4) $(3x+6)(x-3)$

- 563 A figure is made up of a rectangle and a semicircle as shown in the diagram below.

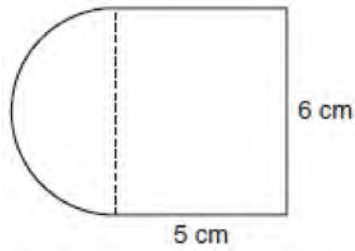

What is the area of the figure, to the nearest tenth of a square centimeter?

- 1) 39.4
 - 2) 44.1
 - 3) 48.8
 - 4) 58.3
- 564 Which expression represents $\frac{x^2 - x - 6}{x^2 - 5x + 6}$ in simplest form?

- 1) $\frac{x+2}{x-2}$
- 2) $\frac{-x-6}{-5x+6}$
- 3) $\frac{1}{5}$
- 4) -1

- 565 What is the solution of the system of equations $2x - 5y = 11$ and $-2x + 3y = -9$?

- 1) $(-3, -1)$
- 2) $(-1, 3)$
- 3) $(3, -1)$
- 4) $(3, 1)$

- 566 The ninth grade class at a local high school needs to purchase a park permit for \$250.00 for their upcoming class picnic. Each ninth grader attending the picnic pays \$0.75. Each guest pays \$1.25. If 200 ninth graders attend the picnic, which inequality can be used to determine the number of guests, x , needed to cover the cost of the permit?

- 1) $0.75x - (1.25)(200) \geq 250.00$
- 2) $0.75x + (1.25)(200) \geq 250.00$
- 3) $(0.75)(200) - 1.25x \geq 250.00$
- 4) $(0.75)(200) + 1.25x \geq 250.00$

- 567 What is the sum of $\frac{3}{2x}$ and $\frac{7}{4x}$?

- 1) $\frac{21}{8x^2}$
- 2) $\frac{13}{4x}$
- 3) $\frac{10}{6x}$
- 4) $\frac{13}{8x}$

- 568 Right triangle ABC has legs of 8 and 15 and a hypotenuse of 17, as shown in the diagram below.

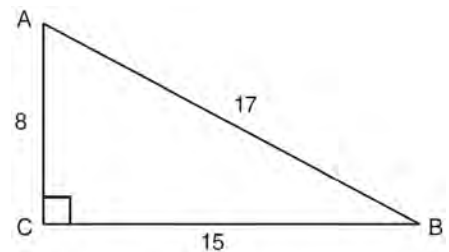

The value of the tangent of $\angle B$ is

- 1) 0.4706
- 2) 0.5333
- 3) 0.8824
- 4) 1.8750

- 569 State the equation of the axis of symmetry and the coordinates of the vertex of the parabola graphed below.

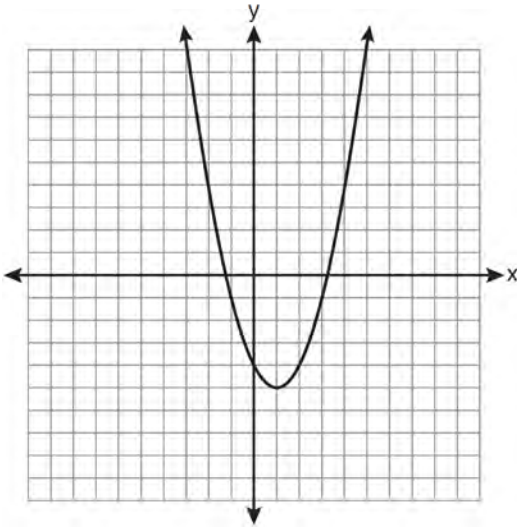

- 570 Which ordered pair is in the solution set of the following system of linear inequalities?

$$y < 2x + 2$$

$$y \geq -x - 1$$

- 1) (0, 3)
 - 2) (2, 0)
 - 3) (-1, 0)
 - 4) (-1, -4)
- 571 A right triangle contains a 38° angle whose adjacent side measures 10 centimeters. What is the length of the hypotenuse, to the *nearest hundredth of a centimeter*?
- 1) 7.88
 - 2) 12.69
 - 3) 12.80
 - 4) 16.24

- 572 Solve the following system of inequalities graphically on the set of axes below.

$$3x + y < 7$$

$$y \geq \frac{2}{3}x - 4$$

State the coordinates of a point in the solution set.

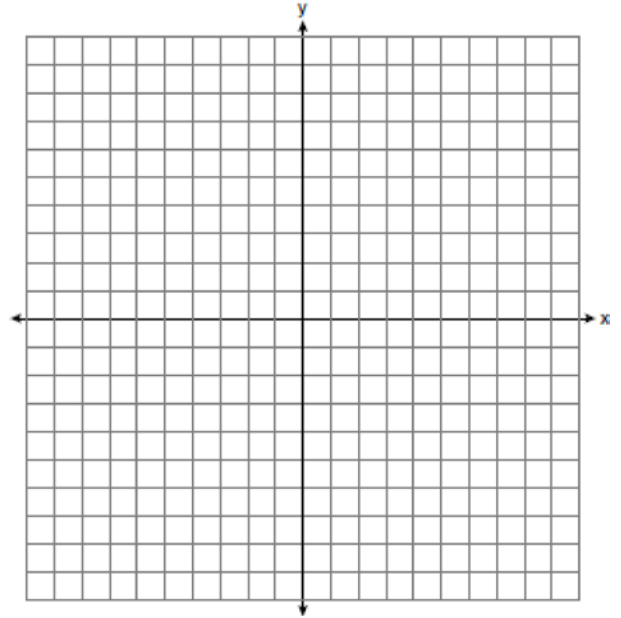

- 573 A survey is being conducted to determine which school board candidate would best serve the Yonkers community. Which group, when randomly surveyed, would likely produce the most bias?
- 1) 15 employees of the Yonkers school district
 - 2) 25 people driving past Yonkers High School
 - 3) 75 people who enter a Yonkers grocery store
 - 4) 100 people who visit the local Yonkers shopping mall

- 574 In right triangle ABC shown below, $AB = 18.3$ and $BC = 11.2$.

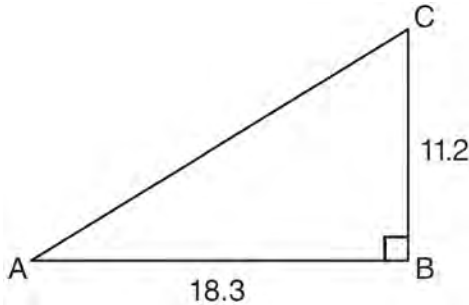

What is the measure of $\angle A$, to the *nearest tenth of a degree*?

- 1) 31.5
- 2) 37.7
- 3) 52.3
- 4) 58.5

- 575 In the diagram below, $MATH$ is a rectangle, $GB = 4.6$, $MH = 6$, and $HT = 15$.

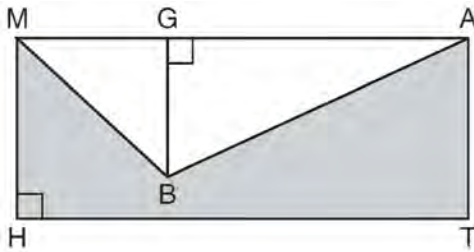

What is the area of polygon $MBATH$?

- 1) 34.5
- 2) 55.5
- 3) 90.0
- 4) 124.5

- 576 Ms. Mosher recorded the math test scores of six students in the table below.

Student	Student Score
Andrew	72
John	80
George	85
Amber	93
Betty	78
Roberto	80

Determine the mean of the student scores, to the *nearest tenth*. Determine the median of the student scores. Describe the effect on the mean and the median if Ms. Mosher adds 5 bonus points to each of the six students' scores.

- 577 Which equation has roots of -3 and 5 ?

- 1) $x^2 + 2x - 15 = 0$
- 2) $x^2 - 2x - 15 = 0$
- 3) $x^2 + 2x + 15 = 0$
- 4) $x^2 - 2x + 15 = 0$

- 578 Which situation does *not* describe a causal relationship?

- 1) The higher the volume on a radio, the louder the sound will be.
- 2) The faster a student types a research paper, the more pages the paper will have.
- 3) The shorter the distance driven, the less gasoline that will be used.
- 4) The slower the pace of a runner, the longer it will take the runner to finish the race.

579 Which verbal expression can be represented by $2(x - 5)$?

- 1) 5 less than 2 times x
- 2) 2 multiplied by x less than 5
- 3) twice the difference of x and 5
- 4) the product of 2 and x , decreased by 5

580 Each of the hats shown below has colored marbles placed inside. Hat A contains five green marbles and four red marbles. Hat B contains six blue marbles and five red marbles. Hat C contains five green marbles and five blue marbles.



If a student were to randomly pick one marble from each of these three hats, determine from which hat the student would most likely pick a green marble. Justify your answer. Determine the fewest number of marbles, if any, and the color of these marbles that could be added to *each* hat so that the probability of picking a green marble will be one-half in each of the three hats.

581 Which expression is equivalent to $-3x(x - 4) - 2x(x + 3)$?

- 1) $-x^2 - 1$
- 2) $-x^2 + 18x$
- 3) $-5x^2 - 6x$
- 4) $-5x^2 + 6x$

582 Maria has a set of 10 index cards labeled with the digits 0 through 9. She puts them in a bag and selects one at random. The outcome that is most likely to occur is selecting

- 1) an odd number
- 2) a prime number
- 3) a number that is at most 5
- 4) a number that is divisible by 3

583 Which ordered pair is a solution to the system of equations $y = x + 3$ and $y = x^2 - x$?

- 1) (6, 9)
- 2) (3, 6)
- 3) (3, -1)
- 4) (2, 5)

584 Graph the solution set for the inequality $4x - 3y > 9$ on the set of axes below. Determine if the point (1, -3) is in the solution set. Justify your answer.

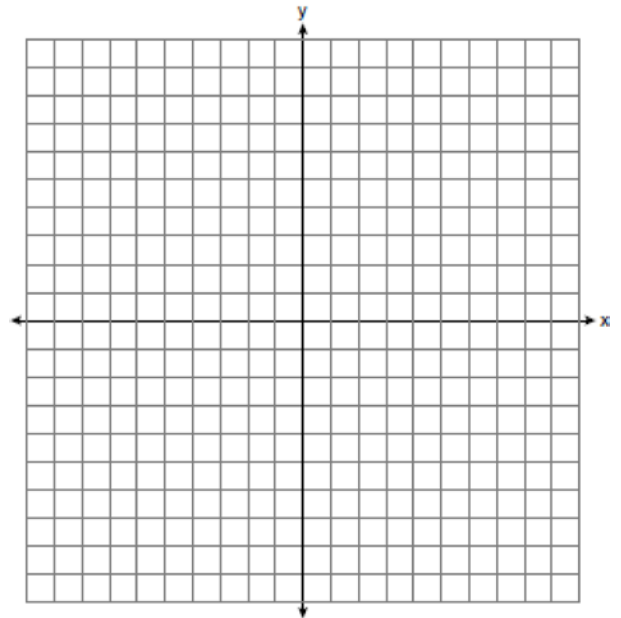

- 585 A spinner that is equally divided into eight numbered sectors is spun 20 times. The table below shows the number of times the arrow landed in each numbered sector.

Spinner Sector	Number of Times
1	2
2	3
3	2
4	3
5	4
6	2
7	3
8	1

Based on the table, what is the empirical probability that the spinner will land on a prime number on the next spin?

- 1) $\frac{9}{20}$
 - 2) $\frac{11}{20}$
 - 3) $\frac{12}{20}$
 - 4) $\frac{14}{20}$
- 586 What is the solution of the system of equations $c + 3d = 8$ and $c = 4d - 6$?
- 1) $c = -14, d = -2$
 - 2) $c = -2, d = 2$
 - 3) $c = 2, d = 2$
 - 4) $c = 14, d = -2$

- 587 Joseph typed a 1,200-word essay in 25 minutes. At this rate, determine how many words he can type in 45 minutes.

- 588 What are the factors of the expression $x^2 + x - 20$?
- 1) $(x + 5)$ and $(x + 4)$
 - 2) $(x + 5)$ and $(x - 4)$
 - 3) $(x - 5)$ and $(x + 4)$
 - 4) $(x - 5)$ and $(x - 4)$

- 589 Given: $A = \{3, 6, 9, 12, 15\}$
 $B = \{2, 4, 6, 8, 10, 12\}$

What is the union of sets A and B ?

- 1) $\{6\}$
- 2) $\{6, 12\}$
- 3) $\{2, 3, 4, 8, 9, 10, 15\}$
- 4) $\{2, 3, 4, 6, 8, 9, 10, 12, 15\}$

- 590 Which expression represents $\frac{12x^3 - 6x^2 + 2x}{2x}$ in simplest form?

- 1) $6x^2 - 3x$
- 2) $10x^2 - 4x$
- 3) $6x^2 - 3x + 1$
- 4) $10x^2 - 4x + 1$

- 591 What is $3\sqrt{2} + \sqrt{8}$ expressed in simplest radical form?

- 1) $3\sqrt{10}$
- 2) $3\sqrt{16}$
- 3) $5\sqrt{2}$
- 4) $7\sqrt{2}$

592 The test scores for 18 students in Ms. Mosher's class are listed below:

86, 81, 79, 71, 58, 87, 52, 71, 87,
 87, 93, 64, 94, 81, 76, 98, 94, 68

Complete the frequency table below.

Interval	Tally	Frequency
51–60		
61–70		
71–80		
81–90		
91–100		

Draw and label a frequency histogram on the grid below.

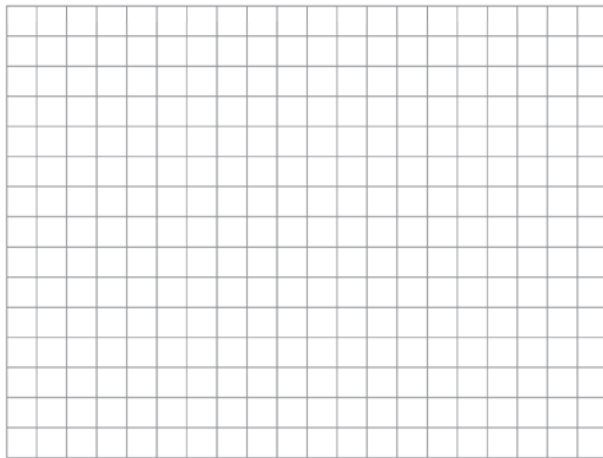

593 Roger is having a picnic for 78 guests. He plans to serve each guest at least one hot dog. If each package, p , contains eight hot dogs, which inequality could be used to determine how many packages of hot dogs Roger will need to buy?

- 1) $p \geq 78$
- 2) $8p \geq 78$
- 3) $8 + p \geq 78$
- 4) $78 - p \geq 8$

594 Find the roots of the equation $x^2 - x = 6$ algebraically.

595 What are the vertex and the axis of symmetry of the parabola shown in the graph below?

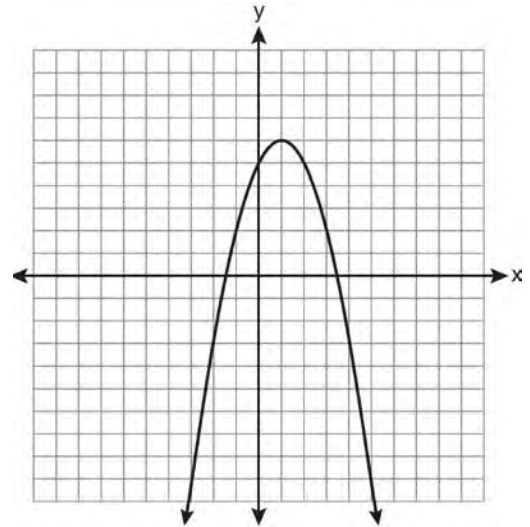

- 1) vertex: (1, 6); axis of symmetry: $y = 1$
- 2) vertex: (1, 6); axis of symmetry: $x = 1$
- 3) vertex: (6, 1); axis of symmetry: $y = 1$
- 4) vertex: (6, 1); axis of symmetry: $x = 1$

596 The number of songs fifteen students have on their MP3 players is:

120, 124, 132, 145, 200, 255, 260, 292,
 308, 314, 342, 407, 421, 435, 452

State the values of the minimum, 1st quartile, median, 3rd quartile, and maximum. Using these values, construct a box-and-whisker plot using an appropriate scale on the line below.

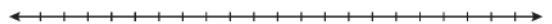

- 597 Debbie solved the linear equation $3(x + 4) - 2 = 16$ as follows:

[Line 1] $3(x + 4) - 2 = 16$

[Line 2] $3(x + 4) = 18$

[Line 3] $3x + 4 = 18$

[Line 4] $3x = 14$

[Line 5] $x = 4\frac{2}{3}$

She made an error between lines

- 1) 1 and 2
 - 2) 2 and 3
 - 3) 3 and 4
 - 4) 4 and 5
- 598 Which interval notation represents the set of all real numbers greater than 2 and less than or equal to 20?
- 1) $(2, 20)$
 - 2) $(2, 20]$
 - 3) $[2, 20)$
 - 4) $[2, 20]$
- 599 Which interval notation represents the set of all numbers greater than or equal to 5 and less than 12?
- 1) $[5, 12)$
 - 2) $(5, 12]$
 - 3) $(5, 12)$
 - 4) $[5, 12]$

- 600 Josh and Mae work at a concession stand. They each earn \$8 per hour. Josh worked three hours more than Mae. If Josh and Mae earned a total of \$120, how many hours did Josh work?
- 1) 6
 - 2) 9
 - 3) 12
 - 4) 15

601 Express $\frac{16\sqrt{21}}{2\sqrt{7}} - 5\sqrt{12}$ in simplest radical form.

- 602 A study showed that a decrease in the cost of carrots led to an increase in the number of carrots sold. Which statement best describes this relationship?
- 1) positive correlation and a causal relationship
 - 2) negative correlation and a causal relationship
 - 3) positive correlation and not a causal relationship
 - 4) negative correlation and not a causal relationship

- 603 What is $3\sqrt{250}$ expressed in simplest radical form?
- 1) $5\sqrt{10}$
 - 2) $8\sqrt{10}$
 - 3) $15\sqrt{10}$
 - 4) $75\sqrt{10}$

604 The diagram below shows right triangle ABC .

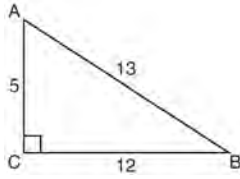

Which ratio represents the tangent of $\angle ABC$?

- 1) $\frac{5}{13}$
- 2) $\frac{5}{12}$
- 3) $\frac{12}{13}$
- 4) $\frac{12}{5}$

605 What is the slope of the line whose equation is $3x - 7y = 9$?

- 1) $-\frac{3}{7}$
- 2) $\frac{3}{7}$
- 3) $-\frac{7}{3}$
- 4) $\frac{7}{3}$

606 Perform the indicated operation: $-6(a - 7)$
State the name of the property used.

607 Find three consecutive positive even integers such that the product of the second and third integers is twenty more than ten times the first integer. [Only an algebraic solution can receive full credit.]

608 What is the relationship between the independent and dependent variables in the scatter plot shown below?

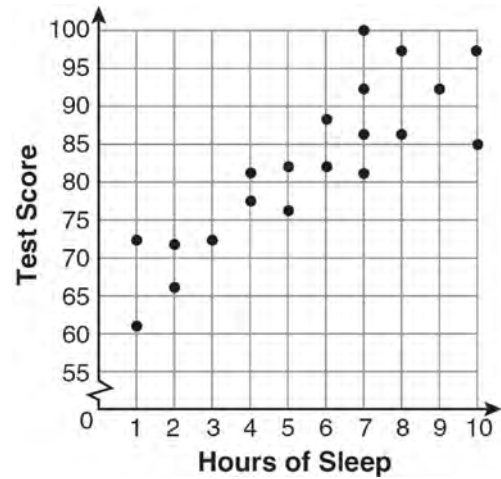

- 1) undefined correlation
- 2) negative correlation
- 3) positive correlation
- 4) no correlation

609 Given the following list of students' scores on a quiz:

5, 12, 7, 15, 20, 14, 7

Determine the median of these scores. Determine the mode of these scores. The teacher decides to adjust these scores by adding three points to each score. Explain the effect, if any, that this will have on the median and mode of these scores.

610 A line having a slope of $\frac{3}{4}$ passes through the point $(-8, 4)$. Write the equation of this line in slope-intercept form.

611 Which graph represents an exponential equation?

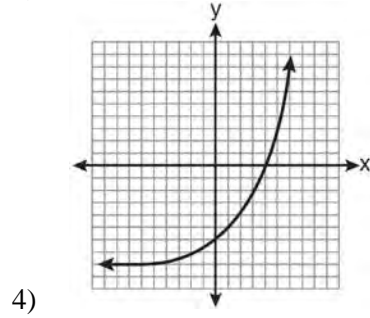
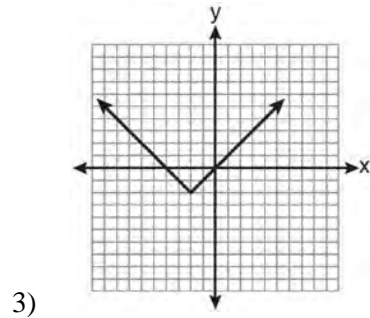
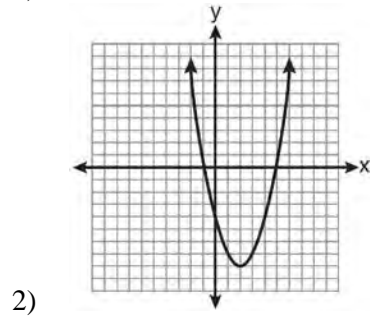
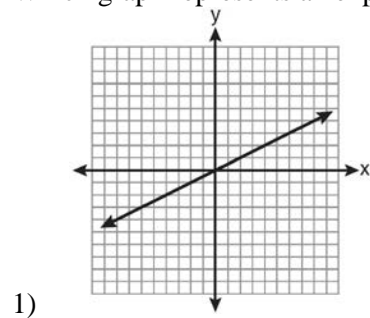

612 Which table does *not* show bivariate data?

1)

Height (inches)	Weight (pounds)
39	50
48	70
60	90

2)

Gallons	Miles Driven
15	300
20	400
25	500

3)

Quiz Average	Frequency
70	12
80	15
90	6

4)

Speed (mph)	Distance (miles)
40	80
50	120
55	150

613 Which expression is equivalent to $3^3 \cdot 3^4$?

- 1) 9^{12}
- 2) 9^7
- 3) 3^{12}
- 4) 3^7

614 How many different ways can five books be arranged on a shelf?

- 1) 5
- 2) 15
- 3) 25
- 4) 120

- 615 Which type of function is represented by the graph shown below?

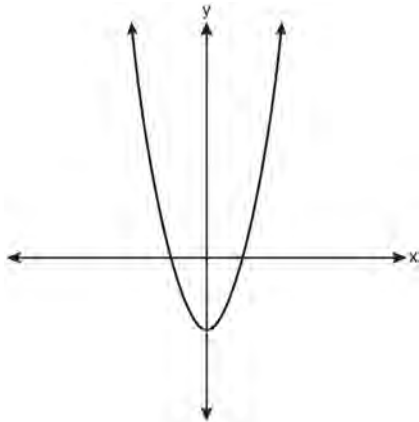

- 1) absolute value
2) exponential
3) linear
4) quadratic
- 616 When 36 is subtracted from the square of a number, the result is five times the number. What is the positive solution?
- 1) 9
2) 6
3) 3
4) 4

- 617 What is $\frac{2+x}{5x} - \frac{x-2}{5x}$ expressed in simplest form?
- 1) 0
2) $\frac{2}{5}$
3) $\frac{4}{5x}$
4) $\frac{2x+4}{5x}$

- 618 Vince buys a box of candy that consists of six chocolate pieces, four fruit-flavored pieces, and two mint pieces. He selects three pieces of candy at random, without replacement. Calculate the probability that the first piece selected will be fruit flavored and the other two will be mint. Calculate the probability that all three pieces selected will be the same type of candy.

- 619 Which linear equation represents a line containing the point (1, 3)?
- 1) $x + 2y = 5$
2) $x - 2y = 5$
3) $2x + y = 5$
4) $2x - y = 5$

- 620 The value of a car purchased for \$20,000 decreases at a rate of 12% per year. What will be the value of the car after 3 years?
- 1) \$12,800.00
2) \$13,629.44
3) \$17,600.00
4) \$28,098.56

- 621 Which point is on the line $4y - 2x = 0$?
- 1) (-2, -1)
2) (-2, 1)
3) (-1, -2)
4) (1, 2)

- 622 Solve for c in terms of a and b : $bc + ac = ab$

623 Solve for m : $\frac{m}{5} + \frac{3(m-1)}{2} = 2(m-3)$

624 What is the sum of $\frac{-x+7}{2x+4}$ and $\frac{2x+5}{2x+4}$?

- 1) $\frac{x+12}{2x+4}$
- 2) $\frac{3x+12}{2x+4}$
- 3) $\frac{x+12}{4x+8}$
- 4) $\frac{3x+12}{4x+8}$

625 A cylinder has a diameter of 10 inches and a height of 2.3 inches. What is the volume of this cylinder, to the nearest tenth of a cubic inch?

- 1) 72.3
- 2) 83.1
- 3) 180.6
- 4) 722.6

626 The members of the senior class are planning a dance. They use the equation $r = pn$ to determine the total receipts. What is n expressed in terms of r and p ?

- 1) $n = r + p$
- 2) $n = r - p$
- 3) $n = \frac{p}{r}$
- 4) $n = \frac{r}{p}$

627 Which scatter plot shows the relationship between x and y if x represents a student score on a test and y represents the number of incorrect answers a student received on the same test?

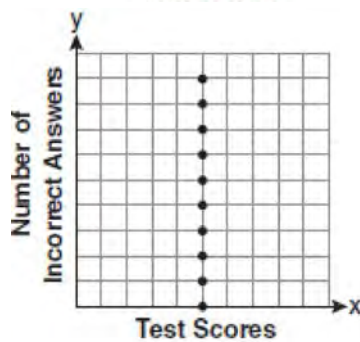
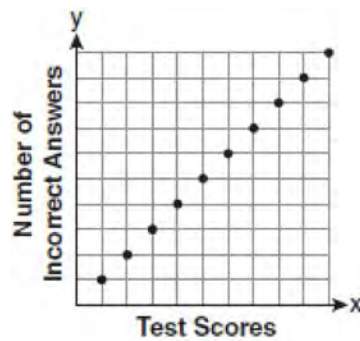
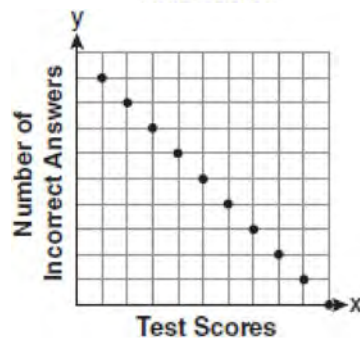
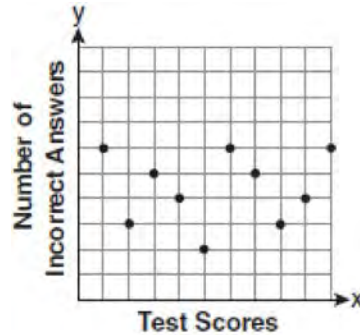

- 628 An 8-foot rope is tied from the top of a pole to a stake in the ground, as shown in the diagram below.

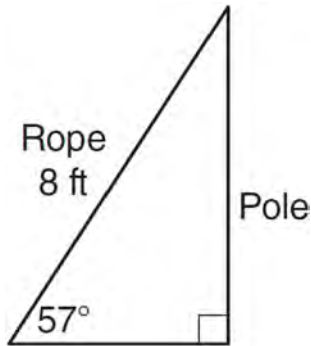

If the rope forms a 57° angle with the ground, what is the height of the pole, to the *nearest tenth of a foot*?

- 1) 4.4
 - 2) 6.7
 - 3) 9.5
 - 4) 12.3
- 629 Which value of x is the solution of $\frac{2x-3}{x-4} = \frac{2}{3}$?

- 1) $-\frac{1}{4}$
- 2) $\frac{1}{4}$
- 3) -4
- 4) 4

- 630 If Ann correctly factors an expression that is the difference of two perfect squares, her factors could be

- 1) $(2x + y)(x - 2y)$
- 2) $(2x + 3y)(2x - 3y)$
- 3) $(x - 4)(x - 4)$
- 4) $(2y - 5)(y - 5)$

- 631 Melissa graphed the equation $y = x^2$ and Dave graphed the equation $y = -3x^2$ on the same coordinate grid. What is the relationship between the graphs that Melissa and Dave drew?

- 1) Dave's graph is wider and opens in the opposite direction from Melissa's graph.
- 2) Dave's graph is narrower and opens in the opposite direction from Melissa's graph.
- 3) Dave's graph is wider and is three units below Melissa's graph.
- 4) Dave's graph is narrower and is three units to the left of Melissa's graph.

- 632 Based on the box-and-whisker plot below, which statement is *false*?

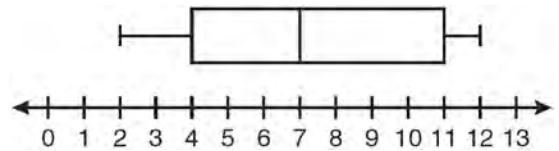

- 1) The median is 7.
- 2) The range is 12.
- 3) The first quartile is 4.
- 4) The third quartile is 11.

- 633 What is the range of the data represented in the box-and-whisker plot shown below?

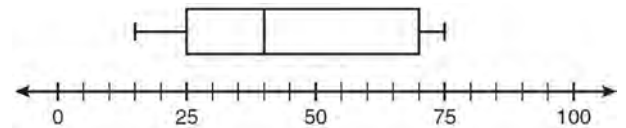

- 1) 40
- 2) 45
- 3) 60
- 4) 100

634 The quotient of (9.2×10^6) and (2.3×10^2) expressed in scientific notation is

- 1) 4,000
- 2) 40,000
- 3) 4×10^3
- 4) 4×10^4

635 A formula used for calculating velocity is

$$v = \frac{1}{2} at^2. \text{ What is } a \text{ expressed in terms of } v \text{ and } t?$$

- 1) $a = \frac{2v}{t}$
- 2) $a = \frac{2v}{t^2}$
- 3) $a = \frac{v}{t}$
- 4) $a = \frac{v}{2t^2}$

636 The expression $\sqrt{72} - 3\sqrt{2}$ written in simplest radical form is

- 1) $5\sqrt{2}$
- 2) $3\sqrt{6}$
- 3) $3\sqrt{2}$
- 4) $\sqrt{6}$

637 In interval notation, the set of all real numbers greater than -6 and less than or equal to 14 is represented by

- 1) $(-6, 14)$
- 2) $[-6, 14)$
- 3) $(-6, 14]$
- 4) $[-6, 14]$

638 What is the sum of $\frac{3x^2}{x-2}$ and $\frac{x^2}{x-2}$?

- 1) $\frac{3x^4}{(x-2)^2}$
- 2) $\frac{3x^4}{x-2}$
- 3) $\frac{4x^2}{(x-2)^2}$
- 4) $\frac{4x^2}{x-2}$

639 Which relation is a function?

- 1) $\left\{ \left(\frac{3}{4}, 0 \right), (0, 1), \left(\frac{3}{4}, 2 \right) \right\}$
- 2) $\left\{ (-2, 2), \left(-\frac{1}{2}, 1 \right), (-2, 4) \right\}$
- 3) $\{(-1, 4), (0, 5), (0, 4)\}$
- 4) $\{(2, 1), (4, 3), (6, 5)\}$

640 The freshman class held a canned food drive for 12 weeks. The results are summarized in the table below.

Canned Food Drive Results

Week	1	2	3	4	5	6	7	8	9	10	11	12
Number of Cans	20	35	32	45	58	46	28	23	31	79	65	62

Which number represents the second quartile of the number of cans of food collected?

- 1) 29.5
- 2) 30.5
- 3) 40
- 4) 60

641 Which equation represents a line parallel to the graph of $2x - 4y = 16$?

- 1) $y = \frac{1}{2}x - 5$
- 2) $y = -\frac{1}{2}x + 4$
- 3) $y = -2x + 6$
- 4) $y = 2x + 8$

642 The sum of $4x^3 + 6x^2 + 2x - 3$ and $3x^3 + 3x^2 - 5x - 5$ is

- 1) $7x^3 + 3x^2 - 3x - 8$
- 2) $7x^3 + 3x^2 + 7x + 2$
- 3) $7x^3 + 9x^2 - 3x - 8$
- 4) $7x^6 + 9x^4 - 3x^2 - 8$

643 If the universal set is {pennies, nickels, dimes, quarters}, what is the complement of the set {nickels}?

- 1) { }
- 2) {pennies, quarters}
- 3) {pennies, dimes, quarters}
- 4) {pennies, nickels, dimes, quarters}

644 Given: $U = \{1, 2, 3, 4, 5, 6, 7, 8\}$

$$B = \{2, 3, 5, 6\}$$

Set B is a subset of set U . What is the complement of set B ?

- 1) { }
- 2) {2, 3, 5, 6}
- 3) {1, 4, 7, 8}
- 4) {1, 2, 3, 4, 5, 6, 7, 8}

645 A trapezoid is shown below.

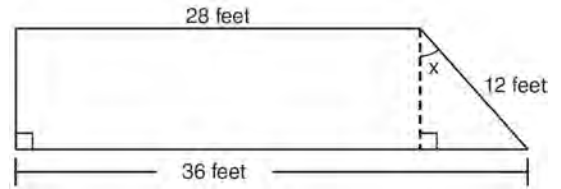

Calculate the measure of angle x , to the nearest tenth of a degree.

646 Which ordered pair is a solution of the system of equations shown in the graph below?

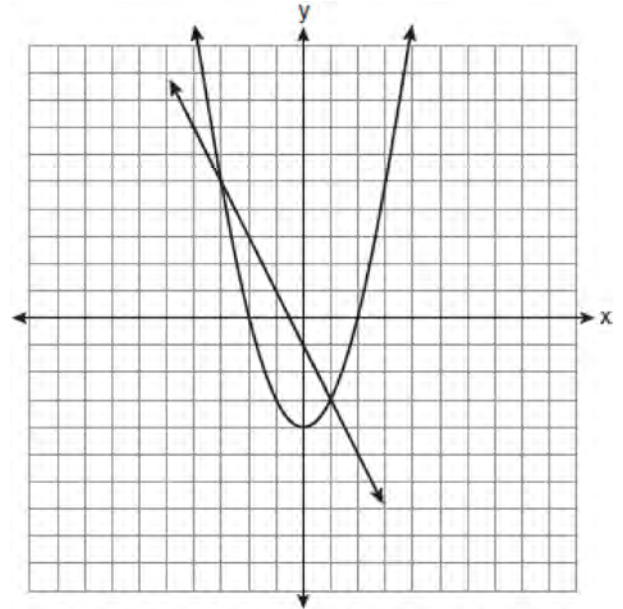

- 1) $(-3, 1)$
- 2) $(-3, 5)$
- 3) $(0, -1)$
- 4) $(0, -4)$

- 647 Which set-builder notation describes $\{-3, -2, -1, 0, 1, 2\}$?
- 1) $\{x \mid -3 \leq x < 2, \text{ where } x \text{ is an integer}\}$
 - 2) $\{x \mid -3 < x \leq 2, \text{ where } x \text{ is an integer}\}$
 - 3) $\{x \mid -3 < x < 2, \text{ where } x \text{ is an integer}\}$
 - 4) $\{x \mid -3 \leq x \leq 2, \text{ where } x \text{ is an integer}\}$
- 648 How many square inches of wrapping paper are needed to entirely cover a box that is 2 inches by 3 inches by 4 inches?
- 1) 18
 - 2) 24
 - 3) 26
 - 4) 52

- 649 Which phrase best describes the relationship between the number of miles driven and the amount of gasoline used?
- 1) causal, but not correlated
 - 2) correlated, but not causal
 - 3) both correlated and causal
 - 4) neither correlated nor causal

- 650 An oil company distributes oil in a metal can shaped like a cylinder that has an actual radius of 5.1 cm and a height of 15.1 cm. A worker incorrectly measured the radius as 5 cm and the height as 15 cm. Determine the relative error in calculating the surface area, to the *nearest thousandth*.

- 651 A plastic storage box in the shape of a rectangular prism has a length of $x + 3$, a width of $x - 4$, and a height of 5. Represent the surface area of the box as a trinomial in terms of x .

- 652 Which value of x is the solution of $\frac{x}{3} + \frac{x+1}{2} = x$?
- 1) 1
 - 2) -1
 - 3) 3
 - 4) -3

- 653 The scatter plot below represents the relationship between the number of peanuts a student eats and the student's bowling score.

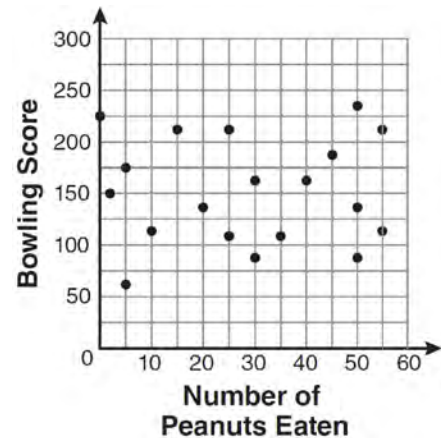

- Which conclusion about the scatter plot is valid?
- 1) There is almost no relationship between eating peanuts and bowling score.
 - 2) Students who eat more peanuts have higher bowling scores.
 - 3) Students who eat more peanuts have lower bowling scores.
 - 4) No bowlers eat peanuts.

- 654 What is the solution of the inequality $-6x - 17 \geq 8x + 25$?
- 1) $x \geq 3$
 - 2) $x \leq 3$
 - 3) $x \geq -3$
 - 4) $x \leq -3$

- 655 What are the vertex and axis of symmetry of the parabola shown in the diagram below?

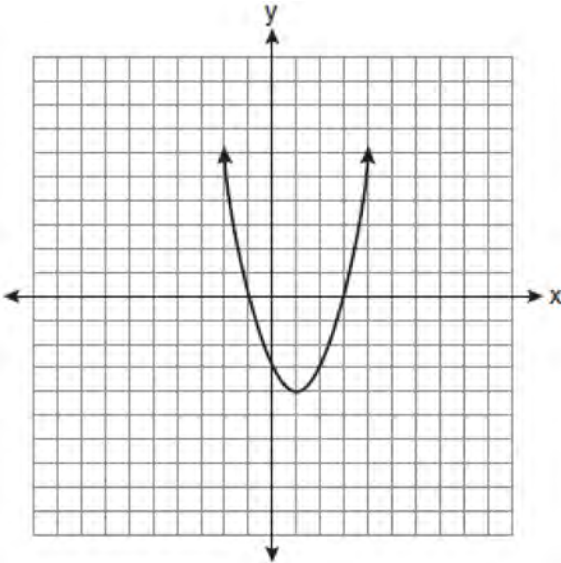

- 1) vertex: (1, -4); axis of symmetry: $x = 1$
 - 2) vertex: (1, -4); axis of symmetry: $x = -4$
 - 3) vertex: (-4, 1); axis of symmetry: $x = 1$
 - 4) vertex: (-4, 1); axis of symmetry: $x = -4$
- 656 Given: $A = \{18, 6, -3, -12\}$
 Determine all elements of set A that are in the solution of the inequality $\frac{2}{3}x + 3 < -2x - 7$.
- 657 Mrs. Chen owns two pieces of property. The areas of the properties are 77,120 square feet and 33,500 square feet.

43,560 square feet = 1 acre

Find the total number of acres Mrs. Chen owns, to the nearest hundredth of an acre.

- 658 The expression $\frac{12w^9y^3}{-3w^3y^3}$ is equivalent to

- 1) $-4w^6$
 - 2) $-4w^3y$
 - 3) $9w^6$
 - 4) $9w^3y$
- 659 What is the value of x in the equation $2(x - 4) = 4(2x + 1)$?
- 1) -2
 - 2) 2
 - 3) $-\frac{1}{2}$
 - 4) $\frac{1}{2}$

- 660 Chelsea has \$45 to spend at the fair. She spends \$20 on admission and \$15 on snacks. She wants to play a game that costs \$0.65 per game. Write an inequality to find the maximum number of times, x , Chelsea can play the game. Using this inequality, determine the maximum number of times she can play the game.

- 661 Express $-3\sqrt{48}$ in simplest radical form.

- 662 An example of an algebraic expression is

- 1) $y = mx + b$
- 2) $3x + 4y - 7$
- 3) $2x + 3y \leq 18$
- 4) $(x + y)(x - y) = 25$

- 663 Which equation shows a correct trigonometric ratio for angle A in the right triangle below?

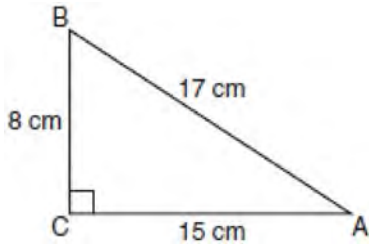

- 1) $\sin A = \frac{15}{17}$
 - 2) $\tan A = \frac{8}{17}$
 - 3) $\cos A = \frac{15}{17}$
 - 4) $\tan A = \frac{5}{8}$
- 664 Which ratio represents $\sin x$ in the right triangle shown below?

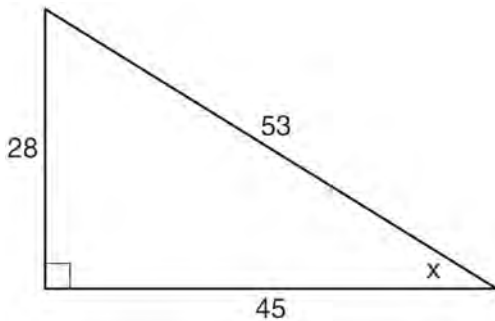

- 1) $\frac{28}{53}$
- 2) $\frac{28}{45}$
- 3) $\frac{45}{53}$
- 4) $\frac{53}{28}$

- 665 What is $\frac{7}{12x} - \frac{y}{6x^2}$ expressed in simplest form?

- 1) $\frac{7-y}{6x}$
- 2) $\frac{7-y}{12x-6x^2}$
- 3) $-\frac{7y}{12x^2}$
- 4) $\frac{7x-2y}{12x^2}$

- 666 The width of a rectangle is 3 less than twice the length, x . If the area of the rectangle is 43 square feet, which equation can be used to find the length, in feet?
- 1) $2x(x-3) = 43$
 - 2) $x(3-2x) = 43$
 - 3) $2x + 2(2x-3) = 43$
 - 4) $x(2x-3) = 43$

- 667 Which value of x is the solution of the equation

$$\frac{2}{3}x + \frac{1}{2} = \frac{5}{6}?$$

- 1) $\frac{1}{2}$
- 2) 2
- 3) $\frac{2}{3}$
- 4) $\frac{3}{2}$

668 Which verbal expression is represented by

$$\frac{1}{2}(n - 3)?$$

- 1) one-half n decreased by 3
- 2) one-half n subtracted from 3
- 3) the difference of one-half n and 3
- 4) one-half the difference of n and 3

669 A communications company is building a 30-foot antenna to carry cell phone transmissions. As shown in the diagram below, a 50-foot wire from the top of the antenna to the ground is used to stabilize the antenna.

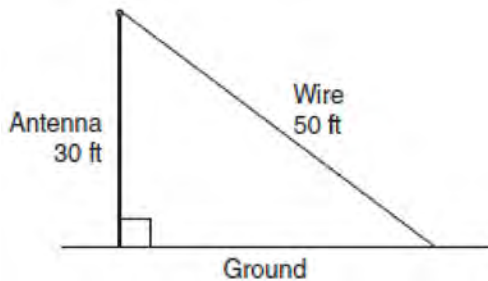

Find, to the *nearest degree*, the measure of the angle that the wire makes with the ground.

670 Which equation represents the line that passes through the points $(-3, 7)$ and $(3, 3)$?

- 1) $y = \frac{2}{3}x + 1$
- 2) $y = \frac{2}{3}x + 9$
- 3) $y = -\frac{2}{3}x + 5$
- 4) $y = -\frac{2}{3}x + 9$

671 In a science fiction novel, the main character found a mysterious rock that decreased in size each day. The table below shows the part of the rock that remained at noon on successive days.

Day	Fractional Part of the Rock Remaining
1	1
2	$\frac{1}{2}$
3	$\frac{1}{4}$
4	$\frac{1}{8}$

Which fractional part of the rock will remain at noon on day 7?

- 1) $\frac{1}{128}$
- 2) $\frac{1}{64}$
- 3) $\frac{1}{14}$
- 4) $\frac{1}{12}$

672 A method for solving $5(x - 2) - 2(x - 5) = 9$ is shown below. Identify the property used to obtain each of the two indicated steps.

$$5(x - 2) - 2(x - 5) = 9$$

(1) $5x - 10 - 2x + 10 = 9$ (1) _____

(2) $5x - 2x - 10 + 10 = 9$ (2) _____

$$3x + 0 = 9$$

$$3x = 9$$

$$x = 3$$

- 673 Which set of data can be classified as qualitative?
1) scores of students in an algebra class
2) ages of students in a biology class
3) numbers of students in history classes
4) eye colors of students in an economics class
- 674 Which equation represents a line parallel to the y-axis?
1) $x = y$
2) $x = 4$
3) $y = 4$
4) $y = x + 4$
- 675 Julia went to the movies and bought one jumbo popcorn and two chocolate chip cookies for \$5.00. Marvin went to the same movie and bought one jumbo popcorn and four chocolate chip cookies for \$6.00. How much does one chocolate chip cookie cost?
1) \$0.50
2) \$0.75
3) \$1.00
4) \$2.00
- 676 When $5x + 4y$ is subtracted from $5x - 4y$, the difference is
1) 0
2) $10x$
3) $8y$
4) $-8y$
- 677 Given: Set $U = \{S, O, P, H, I, A\}$
Set $B = \{A, I, O\}$
If set B is a subset of set U , what is the complement of set B ?
1) $\{O, P, S\}$
2) $\{I, P, S\}$
3) $\{A, H, P\}$
4) $\{H, P, S\}$
- 678 Which expression represents $\frac{-14a^2c^8}{7a^3c^2}$ in simplest form?
1) $-2ac^4$
2) $-2ac^6$
3) $\frac{-2c^4}{a}$
4) $\frac{-2c^6}{a}$
- 679 What is an equation of the axis of symmetry of the parabola represented by $y = -x^2 + 6x - 4$?
1) $x = 3$
2) $y = 3$
3) $x = 6$
4) $y = 6$

680 Which graph could be used to find the solution of the system of equations $y = 2x + 6$ and $y = x^2 + 4x + 3$?

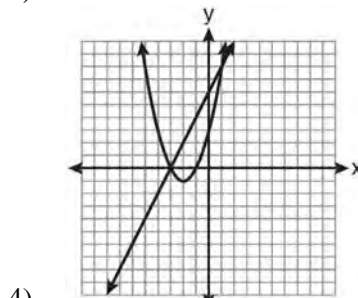
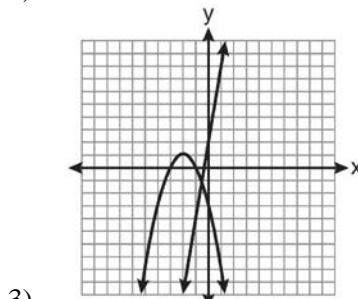
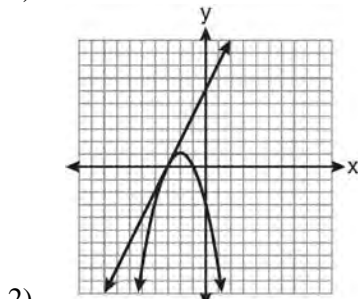
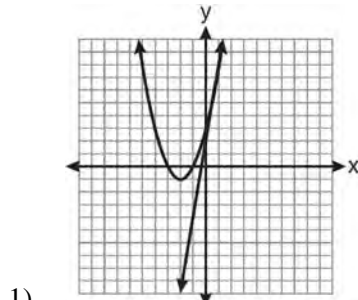

681 A password consists of three digits, 0 through 9, followed by three letters from an alphabet having 26 letters. If repetition of digits is allowed, but repetition of letters is not allowed, determine the number of different passwords that can be made. If repetition is not allowed for digits or letters, determine how many fewer different passwords can be made.

682 A student correctly graphed the parabola shown below to solve a given quadratic equation.

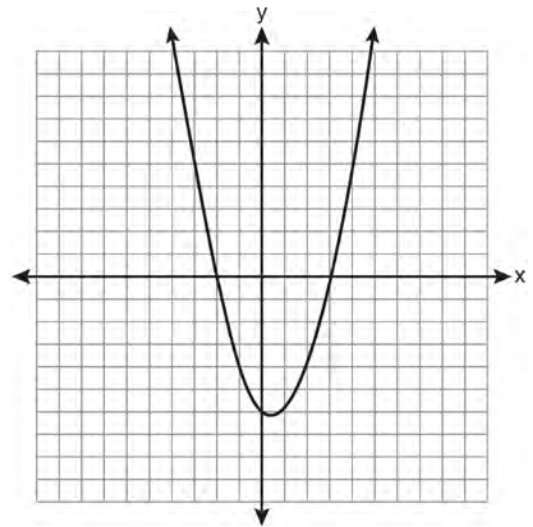

What are the roots of the quadratic equation associated with this graph?

- 1) -6 and 3
- 2) -6 and 0
- 3) -3 and 2
- 4) -2 and 3

- 683 The number of calories burned while jogging varies directly with the number of minutes spent jogging. If George burns 150 calories by jogging for 20 minutes, how many calories does he burn by jogging for 30 minutes?
- 1) 100
 - 2) 180
 - 3) 200
 - 4) 225

- 684 The current student population of the Brentwood Student Center is 2,000. The enrollment at the center increases at a rate of 4% each year. To the nearest whole number, what will the student population be closest to in 3 years'?
- 1) 2,240
 - 2) 2,250
 - 3) 5,488
 - 4) 6,240

- 685 Angela wants to purchase carpeting for her living room. The dimensions of her living room are 12 feet by 12 feet. If carpeting is sold by the square yard, determine how many square yards of carpeting she must purchase.

<p>3 feet = 1 yard 9 square feet = 1 square yard</p>
--

- 686 Which equation represents a line parallel to the y-axis?
- 1) $y = x$
 - 2) $y = 3$
 - 3) $x = -y$
 - 4) $x = -4$

- 687 On the set of axes below, graph and label the equations $y = |x|$ and $y = 3|x|$ for the interval $-3 \leq x \leq 3$.

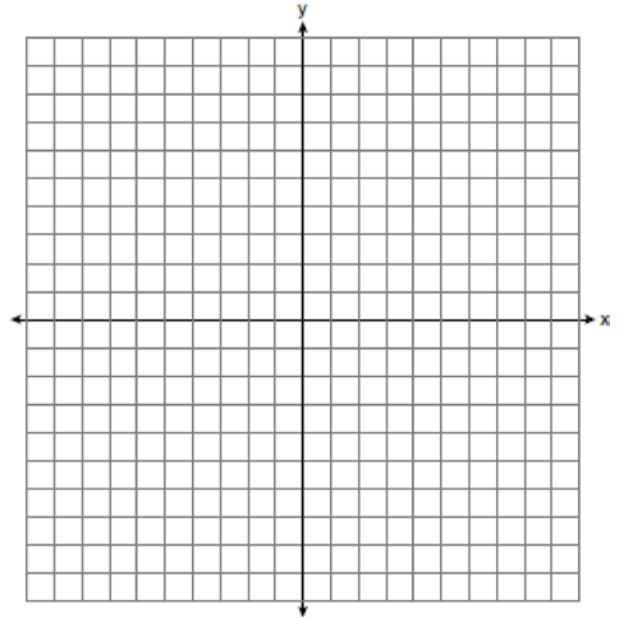

Explain how changing the coefficient of the absolute value from 1 to 3 affects the graph.

- 688 Jon is buying tickets for himself for two concerts. For the jazz concert, 4 tickets are available in the front row, and 32 tickets are available in the other rows. For the orchestra concert, 3 tickets are available in the front row, and 23 tickets are available in the other rows. Jon is randomly assigned one ticket for each concert. Determine the concert for which he is more likely to get a front-row ticket. Justify your answer.

- 689 Graph and label the following equations on the set of axes below.

$$y = |x|$$

$$y = \left| \frac{1}{2}x \right|$$

Explain how *decreasing* the coefficient of x affects the graph of the equation $y = |x|$.

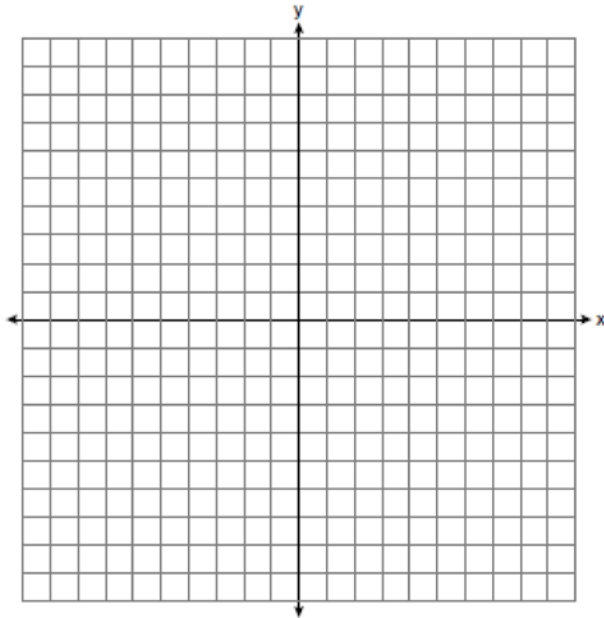

- 690 What is the product of (6×10^3) , (4.6×10^5) , and (2×10^{-2}) expressed in scientific notation?

- 1) 55.2×10^6
- 2) 5.52×10^7
- 3) 55.2×10^7
- 4) 5.52×10^{10}

- 691 Roberta needs ribbon for a craft project. The ribbon sells for \$3.75 per yard. Find the cost, in dollars, for 48 inches of the ribbon.

- 692 Ms. Hopkins recorded her students' final exam scores in the frequency table below.

Interval	Tally	Frequency
61–70	###	5
71–80		4
81–90	###	9
91–100	###	6

On the grid below, construct a frequency histogram based on the table.

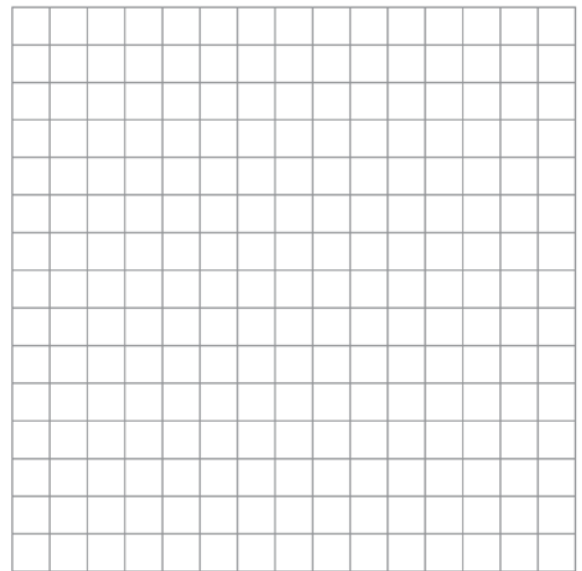

- 693 The box-and-whisker plot below represents the math test scores of 20 students.

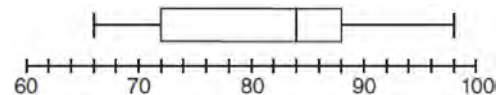

What percentage of the test scores are *less than* 72?

- 1) 25
- 2) 50
- 3) 75
- 4) 100

- 694 The maximum height and speed of various roller coasters in North America are shown in the table below.

Maximum Speed, in mph, (x)	45	50	54	60	65	70
Maximum Height, in feet, (y)	63	80	105	118	141	107

Which graph represents a correct scatter plot of the data?

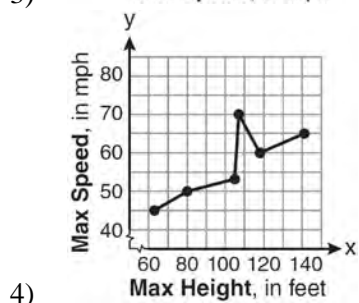
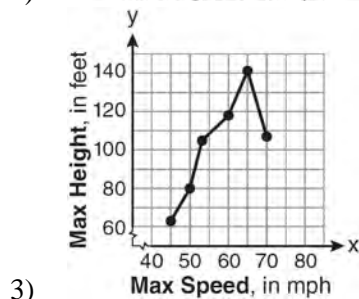
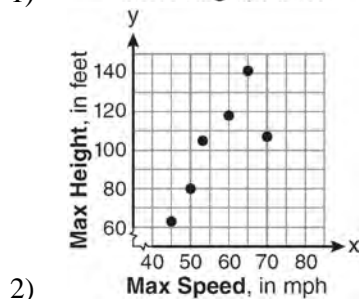
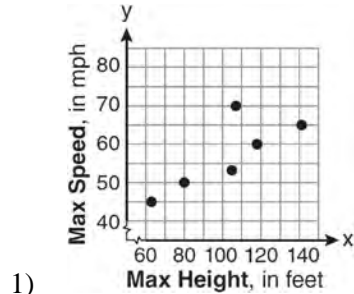

- 695 Which quadrant will be completely shaded in the graph of the inequality $y \leq 2x$?

- 1) Quadrant I
- 2) Quadrant II
- 3) Quadrant III
- 4) Quadrant IV

- 696 A hiker walked 12.8 miles from 9:00 a.m. to noon. He walked an additional 17.2 miles from 1:00 p.m. to 6:00 p.m. What is his average rate for the entire walk, in miles per hour?

- 1) 3.75
- 2) 3.86
- 3) 4.27
- 4) 7.71

- 697 The height, y , of a ball tossed into the air can be represented by the equation $y = -x^2 + 10x + 3$, where x is the elapsed time. What is the equation of the axis of symmetry of this parabola?

- 1) $y = 5$
- 2) $y = -5$
- 3) $x = 5$
- 4) $x = -5$

- 698 What is the solution of $3(2m - 1) \leq 4m + 7$?

- 1) $m \leq 5$
- 2) $m \geq 5$
- 3) $m \leq 4$
- 4) $m \geq 4$

- 699 On the set of axes below, solve the following system of equations graphically for all values of x and y .

$$y = -x^2 - 4x + 12$$

$$y = -2x + 4$$

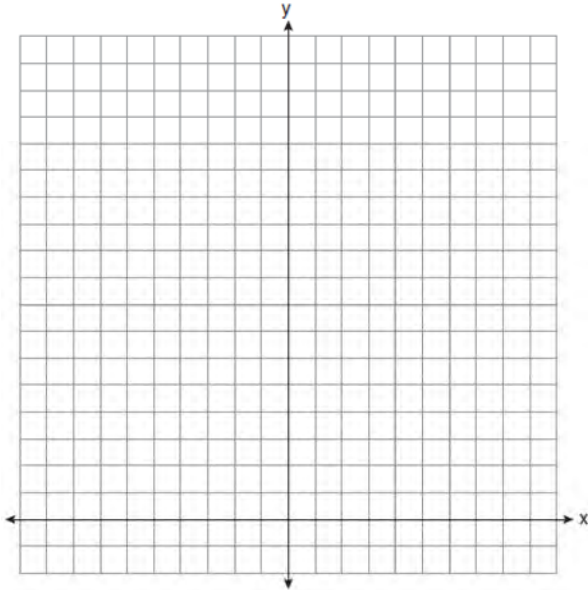

- 700 Steve ran a distance of 150 meters in $1\frac{1}{2}$ minutes.

What is his speed in meters per hour?

- 1) 6
- 2) 60
- 3) 100
- 4) 6,000

- 701 The value, y , of a \$15,000 investment over x years is represented by the equation $y = 15000(1.2)^{\frac{x}{3}}$. What is the profit (interest) on a 6-year investment?

- 1) \$6,600
- 2) \$10,799
- 3) \$21,600
- 4) \$25,799

- 702 Which relation represents a function?

- 1) $\{(0, 3), (2, 4), (0, 6)\}$
- 2) $\{(-7, 5), (-7, 1), (-10, 3), (-4, 3)\}$
- 3) $\{(2, 0), (6, 2), (6, -2)\}$
- 4) $\{(-6, 5), (-3, 2), (1, 2), (6, 5)\}$

- 703 The spinner shown in the diagram below is divided into six equal sections.

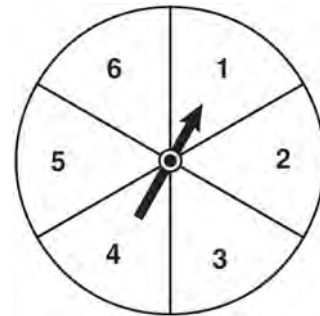

Which outcome is *least* likely to occur on a single spin?

- 1) an odd number
- 2) a prime number
- 3) a perfect square
- 4) a number divisible by 2

704 Which data table represents univariate data?

1)

Side Length of a Square	Area of Square
2	4
3	9
4	16
5	25

2)

Hours Worked	Pay
20	\$160
25	\$200
30	\$240
35	\$280

3)

Age Group	Frequency
20–29	9
30–39	7
40–49	10
50–59	4

4)

People	Number of Fingers
2	20
3	30
4	40
5	50

705 Which graph represents a function?

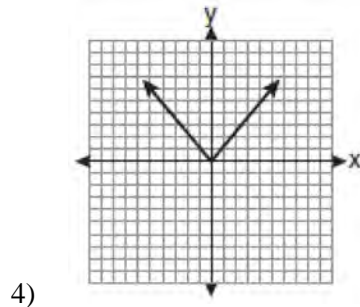
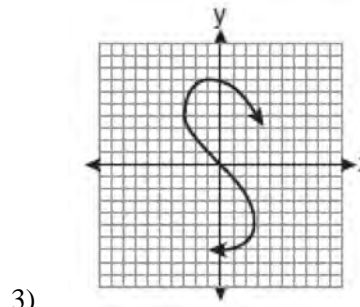
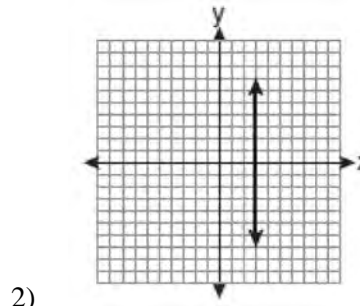
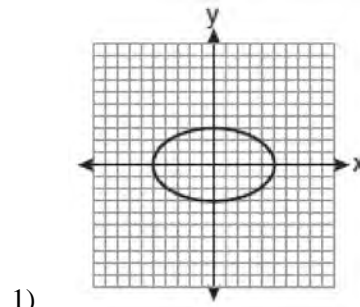

706 Which graph can be used to find the solution of the following system of equations?

$$y = x^2 + 2x + 3$$

$$2y - 2x = 10$$

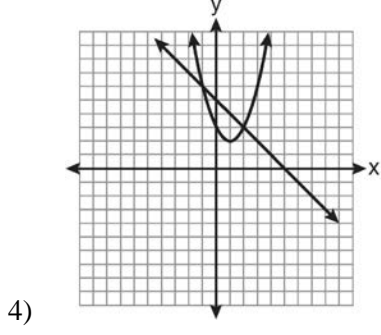
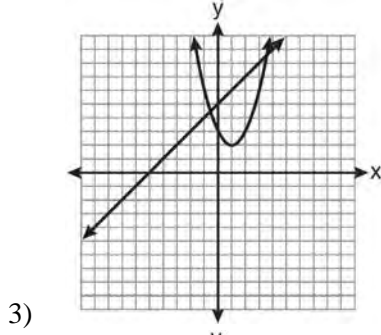
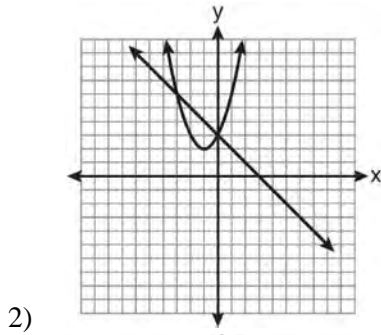
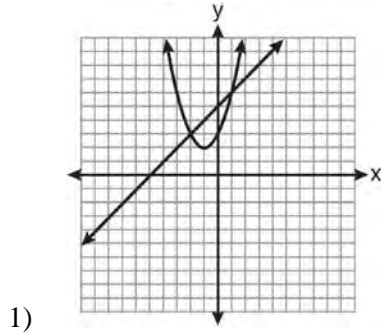

707 Express in simplest form: $\frac{45a^4b^3 - 90a^3b}{15a^2b}$

708 The algebraic expression $\frac{x-2}{x^2-9}$ is undefined when

x is

- 1) 0
- 2) 2
- 3) 3
- 4) 9

709 The expression $6\sqrt{50} + 6\sqrt{2}$ written in simplest radical form is

- 1) $6\sqrt{52}$
- 2) $12\sqrt{52}$
- 3) $17\sqrt{2}$
- 4) $36\sqrt{2}$

710 How many different three-letter arrangements can be formed using the letters in the word *ABSOLUTE* if each letter is used only once?

- 1) 56
- 2) 112
- 3) 168
- 4) 336

711 What is the value of the y -coordinate of the solution to the system of equations $2x + y = 8$ and $x - 3y = -3$?

- 1) -2
- 2) 2
- 3) 3
- 4) -3

- 712 A garden is in the shape of an isosceles trapezoid and a semicircle, as shown in the diagram below. A fence will be put around the perimeter of the entire garden.

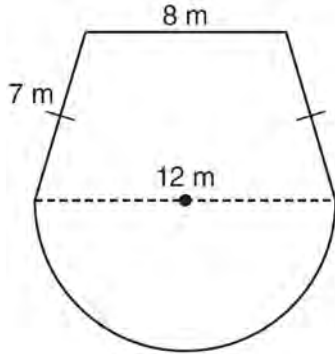

Which expression represents the length of fencing, in meters, that will be needed?

- 1) $22 + 6\pi$
 2) $22 + 12\pi$
 3) $15 + 6\pi$
 4) $15 + 12\pi$
- 713 The graphs of the equations $y = 2x - 7$ and $y - kx = 7$ are parallel when k equals
- 1) -2
 2) 2
 3) -7
 4) 7
- 714 What is an equation of the line that passes through the points $(1, 3)$ and $(8, 5)$?
- 1) $y + 1 = \frac{2}{7}(x + 3)$
 2) $y - 5 = \frac{2}{7}(x - 8)$
 3) $y - 1 = \frac{2}{7}(x + 3)$
 4) $y + 5 = \frac{2}{7}(x - 8)$

- 715 Sam's grades on eleven chemistry tests were 90, 85, 76, 63, 94, 89, 81, 76, 78, 69, and 97. Which statement is true about the measures of central tendency?
- 1) mean $>$ mode
 2) mean $<$ median
 3) mode $>$ median
 4) median = mean

- 716 Graph the following systems of inequalities on the set of axes shown below and label the solution set S :

$$y > -x + 2$$

$$y \leq \frac{2}{3}x + 5$$

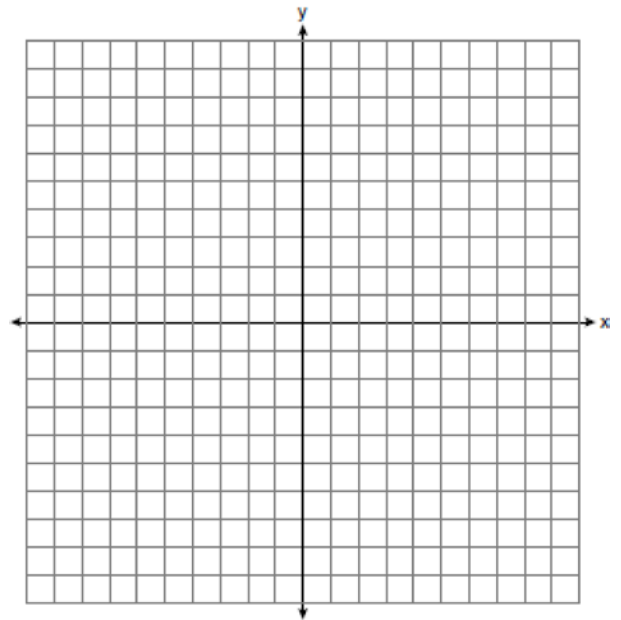

- 717 Find the roots of the equation $x^2 = 30 - 13x$ algebraically.

718 The school store did a study comparing the cost of a sweatshirt with the number of sweatshirts sold. The price was changed several times and the numbers of sweatshirts sold were recorded. The data are shown in the table below.

Cost of Sweatshirt	\$10	\$25	\$15	\$20	\$5
Number Sold	9	6	15	11	14

Which scatter plot represents the data?

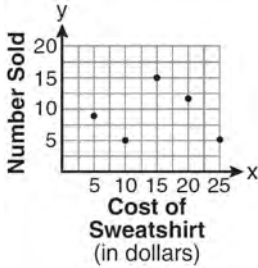

1)

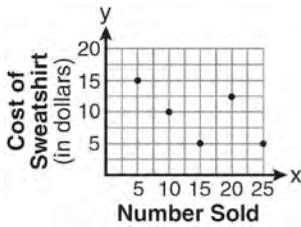

2)

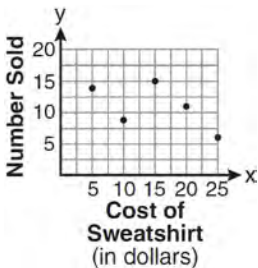

3)

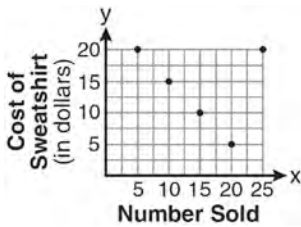

4)

719 Tim ate four more cookies than Alice. Bob ate twice as many cookies as Tim. If x represents the number of cookies Alice ate, which expression represents the number of cookies Bob ate?

- 1) $2 + (x + 4)$
- 2) $2x + 4$
- 3) $2(x + 4)$
- 4) $4(x + 2)$

720 The expression $\frac{(10w^3)^2}{5w}$ is equivalent to

- 1) $2w^5$
- 2) $2w^8$
- 3) $20w^5$
- 4) $20w^8$

721 What are the roots of the equation $x^2 - 5x + 6 = 0$?

- 1) 1 and -6
- 2) 2 and 3
- 3) -1 and 6
- 4) -2 and -3

722 Solve algebraically for x : $\frac{x+2}{6} = \frac{3}{x-1}$

723 The Booster Club raised \$30,000 for a sports fund. No more money will be placed into the fund. Each year the fund will decrease by 5%. Determine the amount of money, to the *nearest cent*, that will be left in the sports fund after 4 years.

724 The diagram below shows the graph of $y = -x^2 - c$.

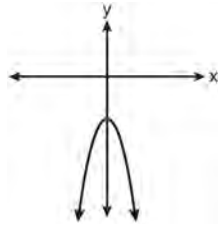

Which diagram shows the graph of $y = x^2 - c$?

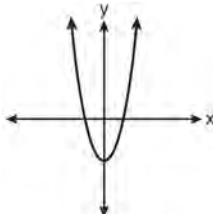
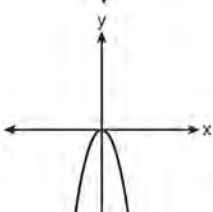
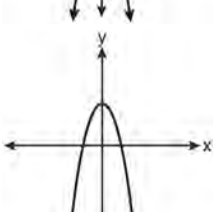
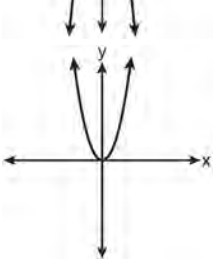
- 1) 
- 2) 
- 3) 
- 4) 

725 Which expression is equivalent to $121 - x^2$?

- 1) $(x - 11)(x - 11)$
- 2) $(x + 11)(x - 11)$
- 3) $(11 - x)(11 + x)$
- 4) $(11 - x)(11 - x)$

726 Corinne calculated the area of a paper plate to be 50.27 square inches. If the actual area of the plate is 55.42 square inches, what is the relative error in calculating the area, to the nearest thousandth?

- 1) 0.092
- 2) 0.093
- 3) 0.102
- 4) 0.103

727 In $\triangle ABC$, the measure of $\angle B = 90^\circ$, $AC = 50$, $AB = 48$, and $BC = 14$. Which ratio represents the tangent of $\angle A$?

- 1) $\frac{14}{50}$
- 2) $\frac{14}{48}$
- 3) $\frac{48}{50}$
- 4) $\frac{48}{14}$

728 What is the perimeter of a regular pentagon with a side whose length is $x + 4$?

- 1) $x^2 + 16$
- 2) $4x + 16$
- 3) $5x + 4$
- 4) $5x + 20$

729 The expression $x^2 - 36y^2$ is equivalent to

- 1) $(x - 6y)(x - 6y)$
- 2) $(x - 18y)(x - 18y)$
- 3) $(x + 6y)(x - 6y)$
- 4) $(x + 18y)(x - 18y)$

- 730 The rectangle shown below has a diagonal of 18.4 cm and a width of 7 cm.

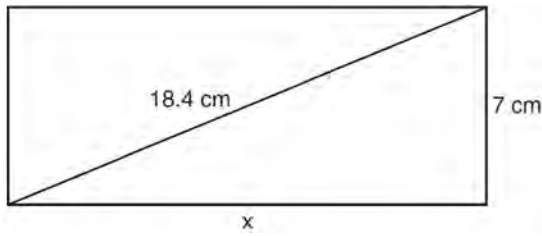

To the *nearest centimeter*, what is the length, x , of the rectangle?

- 1) 11
2) 17
3) 20
4) 25
- 731 Which equation represents the line that passes through the point $(1, 5)$ and has a slope of -2 ?
- 1) $y = -2x + 7$
2) $y = -2x + 11$
3) $y = 2x - 9$
4) $y = 2x + 3$
- 732 An outfit Jennifer wears to school consists of a top, a bottom, and shoes. Possible choices are listed below.

Tops: T-shirt, blouse, sweater
Bottoms: jeans, skirt, capris
Shoes: flip-flops, sneakers

List the sample space or draw a tree diagram to represent all possible outfits consisting of one type of top, one type of bottom, and one pair of shoes. Determine how many different outfits contain jeans and flip-flops. Determine how many different outfits do *not* include a sweater.

- 733 How many different sandwiches consisting of one type of cheese, one condiment, and one bread choice can be prepared from five types of cheese, two condiments, and three bread choices?
- 1) 10
2) 13
3) 15
4) 30
- 734 Using his ruler, Howell measured the sides of a rectangular prism to be 5 cm by 8 cm by 4 cm. The actual measurements are 5.3 cm by 8.2 cm by 4.1 cm. Find Howell's relative error in calculating the volume of the prism, to the *nearest thousandth*.
- 735 The probability that it will snow on Sunday is $\frac{3}{5}$. The probability that it will snow on both Sunday and Monday is $\frac{3}{10}$. What is the probability that it will snow on Monday, if it snowed on Sunday?
- 1) $\frac{9}{50}$
2) 2
3) $\frac{1}{2}$
4) $\frac{9}{10}$

- 736 On the set of axes below, solve the following system of inequalities graphically.

$$y < 2x + 1$$

$$y \geq -\frac{1}{3}x + 4$$

State the coordinates of a point in the solution set.

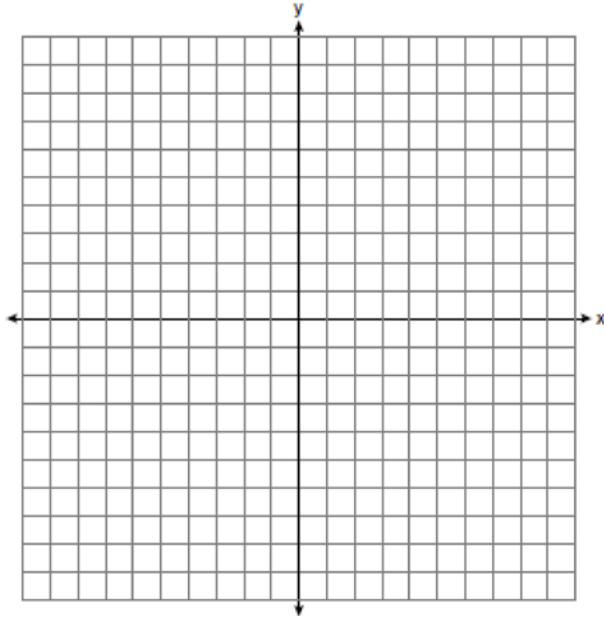

- 737 Which situation describes a correlation that is *not* a causal relationship?
- 1) the length of the edge of a cube and the volume of the cube
 - 2) the distance traveled and the time spent driving
 - 3) the age of a child and the number of siblings the child has
 - 4) the number of classes taught in a school and the number of teachers employed

738 Solve algebraically for x : $\frac{3}{4} = \frac{-(x+11)}{4x} + \frac{1}{2x}$

- 739 How many different four-letter arrangements are possible with the letters G, A, R, D, E, N if each letter may be used only once?

- 1) 15
- 2) 24
- 3) 360
- 4) 720

- 740 What is the result when $2x^2 + 3xy - 6$ is subtracted from $x^2 - 7xy + 2$?

- 1) $-x^2 - 10xy + 8$
- 2) $x^2 + 10xy - 8$
- 3) $-x^2 - 4xy - 4$
- 4) $x^2 - 4xy - 4$

- 741 The figure shown below is composed of two rectangles and a quarter circle.

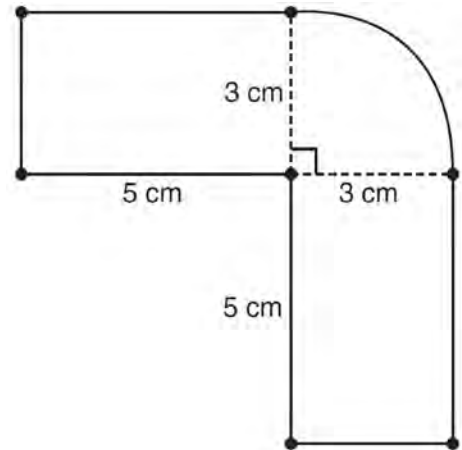

What is the area of this figure, to the *nearest square centimeter*?

- 1) 33
- 2) 37
- 3) 44
- 4) 58

Integrated Algebra Regents at Random Answer Section

1 ANS:

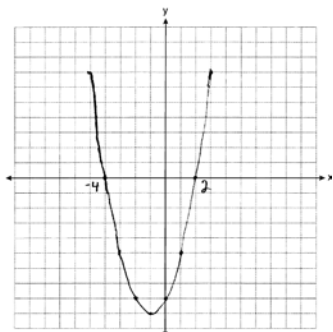

PTS: 3

REF: 061234ia

STA: A.G.8

TOP: Solving Quadratics by Graphing

2 ANS: 4

$$m = \frac{-A}{B} = \frac{-(-3)}{2} = \frac{3}{2}$$

PTS: 2

REF: 061212ia

STA: A.A.37

TOP: Slope

3 ANS: 2

PTS: 2

REF: 061312ia

STA: A.A.12

TOP: Powers of Powers

4 ANS: 1

$$\sqrt{1700^2 - 1300^2} \approx 1095$$

PTS: 2

REF: 011221ia

STA: A.A.45

TOP: Pythagorean Theorem

5 ANS: 4

$$\frac{95000}{125000} = .76$$

PTS: 2

REF: 061207ia

STA: A.S.11

TOP: Quartiles and Percentiles

6 ANS:

$$5x^3 - 20x^2 - 60x$$

$$5x(x^2 - 4x - 12)$$

$$5x(x + 2)(x - 6)$$

PTS: 2

REF: 011332ia

STA: A.A.20

TOP: Factoring Polynomials

7 ANS: 2

PTS: 2

REF: 011316ia

STA: A.A.14

TOP: Division of Polynomials

8 ANS: 4

PTS: 2

REF: 081321ia

STA: A.A.29

TOP: Set Theory

9 ANS: 3

PTS: 2

REF: 011205ia

STA: A.A.1

TOP: Expressions

10 ANS: 1

$$x^2 + 5x - 6 = 0$$

$$(x + 6)(x - 1) = 0$$

$$x = -6, 1$$

PTS: 2

REF: 011214ia

STA: A.A.15

TOP: Undefined Rationals

11 ANS: 4

PTS: 2

REF: 081214ia

STA: A.G.10

TOP: Identifying the Vertex of a Quadratic Given Graph

12 ANS: 2

$$\frac{x^2 - 3x - 10}{x^2 - 25} = \frac{(x - 5)(x + 2)}{(x + 5)(x - 5)} = \frac{x + 2}{x + 5}$$

PTS: 2

REF: 061216ia

STA: A.A.16

TOP: Rational Expressions

KEY: $a > 0$

13 ANS: 3

PTS: 2

REF: 011224ia

STA: A.N.1

TOP: Properties of Reals

14 ANS: 4

$$3x^3 - 33x^2 + 90x = 3x(x^2 - 11x + 30) = 3x(x - 5)(x - 6)$$

PTS: 2

REF: 061227ia

STA: A.A.20

TOP: Factoring Polynomials

15 ANS: 3

$$\frac{10^3}{5^3} = \frac{1000}{125} = 8$$

PTS: 2

REF: 011312ia

STA: A.G.2

TOP: Volume

16 ANS: 1

$$x = \frac{-b}{2a} = \frac{-(-3)}{2(2)} = \frac{3}{4}$$

PTS: 2

REF: 011219ia

STA: A.A.41

TOP: Identifying the Vertex of a Quadratic Given Equation

17 ANS: 4

PTS: 2

REF: 011225ia

STA: A.A.31

TOP: Set Theory

18 ANS: 3

PTS: 2

REF: 061323ia

STA: A.A.1

TOP: Expressions

19 ANS: 4

PTS: 2

REF: 061226ia

STA: A.A.13

TOP: Addition and Subtraction of Polynomials

KEY: subtraction

20 ANS: 2

$$m = \frac{-7 - 1}{4 - 9} = \frac{-8}{-5} = \frac{8}{5}$$

PTS: 2

REF: 081310ia

STA: A.A.33

TOP: Slope

21 ANS: 2

$$13^2 + 13^2 = x^2$$

$$338 = x^2$$

$$\sqrt{338} = x$$

$$18 \approx x$$

PTS: 2 REF: 061223ia STA: A.A.45 TOP: Pythagorean Theorem

22 ANS: 3 PTS: 2 REF: 061306ia STA: A.G.8

TOP: Solving Quadratics by Graphing

23 ANS: 4

$$V = \pi r^2 h$$

$$32\pi = \pi r^2(2)$$

$$16 = r^2$$

$$4 = r$$

PTS: 2 REF: 081224ia STA: A.G.2 TOP: Volume

24 ANS:

$$-5(x - 7) < 15$$

$$x - 7 > -3$$

$$x > 4$$

PTS: 2 REF: 061331ia STA: A.A.24 TOP: Solving Inequalities

25 ANS: 3

$$\frac{2}{x+1} = \frac{x+1}{2}$$

$$x^2 + 2x + 1 = 4$$

$$x^2 + 2x - 3 = 0$$

$$(x+3)(x-1) = 3$$

$$x = -3, 1$$

PTS: 2 REF: 081226ia STA: A.A.26 TOP: Solving Rationals

26 ANS:

$$6\sqrt{3} \frac{3\sqrt{75} + \sqrt{27}}{3} = \frac{3\sqrt{25}\sqrt{3} + \sqrt{9}\sqrt{3}}{3} = \frac{15\sqrt{3} + 3\sqrt{3}}{3} = \frac{18\sqrt{3}}{3} = 6\sqrt{3}$$

PTS: 3 REF: 061236ia STA: A.N.3 TOP: Operations with Radicals

27 ANS: 3 PTS: 2 REF: 061303ia STA: A.S.17

TOP: Scatter Plots

28 ANS: 1

$$m = -3$$

PTS: 2 REF: 081307ia STA: A.A.38 TOP: Parallel and Perpendicular Lines

- 29 ANS: 2 PTS: 2 REF: 081215ia STA: A.A.1
TOP: Expressions
- 30 ANS: 3
 ${}_{18}P_3 = 4896$
- PTS: 2 REF: 061328ia STA: A.N.8 TOP: Permutations
- 31 ANS: 3
 $(3x + 2)(x - 7) = 3x^2 - 21x + 2x - 14 = 3x^2 - 19x - 14$
- PTS: 2 REF: 061210ia STA: A.A.13 TOP: Multiplication of Polynomials
- 32 ANS:
4. $3(x + 1) - 5x = 12 - (6x - 7)$
 $3x + 3 - 5x = 12 - 6x + 7$
 $-2x + 3 = -6x + 19$
 $4x = 16$
 $x = 4$
- PTS: 4 REF: 061238ia STA: A.A.22 TOP: Solving Equations
- 33 ANS: 2 PTS: 2 REF: 081212ia STA: A.A.5
TOP: Modeling Inequalities
- 34 ANS: 1 PTS: 2 REF: 081315ia STA: A.A.10
TOP: Solving Linear Systems
- 35 ANS: 3
 $A \cup C = \{1, 2, 3, 5, 7, 9\}$
- PTS: 2 REF: 081221ia STA: A.A.31 TOP: Set Theory
- 36 ANS: 3
 $2\sqrt{45} = 2\sqrt{9} \sqrt{5} = 6\sqrt{5}$
- PTS: 2 REF: 011203ia STA: A.N.2 TOP: Simplifying Radicals
- 37 ANS:
 $t = \frac{d}{s} = \frac{136,000,000}{31,000} \approx 4387.1 \text{ hours. } \frac{4387.1}{24} \approx 183$
- PTS: 2 REF: 061333ia STA: A.M.1 TOP: Speed
- 38 ANS: 2 PTS: 2 REF: 081327ia STA: A.S.16
TOP: Central Tendency
- 39 ANS: 3 PTS: 2 REF: 081211ia STA: A.A.9
TOP: Exponential Functions
- 40 ANS: 4 PTS: 2 REF: 011308ia STA: A.S.18
TOP: Conditional Probability

- 41 ANS: 3
 $0.06y + 200 = 0.03y + 350$
 $0.03y = 150$
 $y = 5,000$
- PTS: 2 REF: 081203ia STA: A.A.25 TOP: Solving Equations with Decimals
- 42 ANS: 2
mean = 7, median = 6 and mode = 6
- PTS: 2 REF: 011329ia STA: A.S.4 TOP: Central Tendency
- 43 ANS: 3 PTS: 2 REF: 011324ia STA: A.A.36
TOP: Parallel and Perpendicular Lines
- 44 ANS: 4
 $x^2 - 14x + 48 = 0$
 $(x - 6)(x - 8) = 0$
 $x = 6, 8$
- PTS: 2 REF: 011320ia STA: A.A.28 TOP: Roots of Quadratics
- 45 ANS: 4 PTS: 2 REF: 061221ia STA: A.G.4
TOP: Identifying the Equation of a Graph
- 46 ANS: 3 PTS: 2 REF: 011310ia STA: A.A.9
TOP: Exponential Functions
- 47 ANS:
 $\tan x = \frac{350}{1000}$
 $x \approx 19$
- PTS: 3 REF: 061335ia STA: A.A.43 TOP: Using Trigonometry to Find an Angle
- 48 ANS: 4 PTS: 2 REF: 061203ia STA: A.A.14
TOP: Division of Polynomials
- 49 ANS:
 $\tan 48 = \frac{9}{x}$. $\sin 48 = \frac{9}{y}$
 $x \approx 8$ $y \approx 12$
- PTS: 4 REF: 011338ia STA: A.A.44 TOP: Using Trigonometry to Find a Side
- 50 ANS: 3 PTS: 2 REF: 011315ia STA: A.G.1
TOP: Compositions of Polygons and Circles
KEY: area
- 51 ANS:
2. Subtracting the equations: $3y = 6$
 $y = 2$
- PTS: 2 REF: 061231ia STA: A.A.10 TOP: Solving Linear Systems

- 52 ANS: 2 PTS: 2 REF: 081205ia STA: A.A.13
TOP: Addition and Subtraction of Polynomials KEY: addition
- 53 ANS: 1
$$\frac{20-6}{(20-6)+15+7+8} = \frac{14}{44}$$
- PTS: 2 REF: 061302ia STA: A.S.18 TOP: Conditional Probability
- 54 ANS: 1
$$\frac{1}{7} + \frac{2x}{3} = \frac{15x-3}{21}$$

$$\frac{14x+3}{21} = \frac{15x-3}{21}$$

$$14x+3 = 15x-3$$

$$x = 6$$
- PTS: 2 REF: 011328ia STA: A.A.25
TOP: Solving Equations with Fractional Expressions
- 55 ANS:
$$259.99 \times 1.07 - 259.99(1 - 0.3) \times 1.07 = 83.46$$
- PTS: 4 REF: 011239ia STA: A.N.5 TOP: Percents
- 56 ANS: 1
The other situations are quantitative.
- PTS: 2 REF: 061308ia STA: A.S.1 TOP: Analysis of Data
- 57 ANS: 3 PTS: 2 REF: 061206ia STA: A.S.2
TOP: Analysis of Data
- 58 ANS: 1 PTS: 2 REF: 011306ia STA: A.A.19
TOP: Factoring the Difference of Perfect Squares
- 59 ANS:
$$\frac{8100-7678.5}{7678.5} \approx 0.055$$
- PTS: 2 REF: 061233ia STA: A.M.3 TOP: Error
KEY: area
- 60 ANS: 1
$$\frac{\text{distance}}{\text{time}} = \frac{350.7}{4.2} = 83.5$$
- PTS: 2 REF: 061201ia STA: A.M.1 TOP: Speed
- 61 ANS: 1
$$3x^2 - 27x = 0$$

$$3x(x-9) = 0$$

$$x = 0, 9$$
- PTS: 2 REF: 011223ia STA: A.A.28 TOP: Roots of Quadratics

62 ANS: 4

$$3y + 2x = 8$$

$$3(-2) + 2(7) = 8$$

$$-6 + 14 = 8$$

PTS: 2 REF: 011218ia STA: A.A.39 TOP: Identifying Points on a Line

63 ANS: 4

$$8900 \text{ ft} \times \frac{1 \text{ mi}}{5280 \text{ ft}} \approx 1.7 \text{ mi}$$

PTS: 2 REF: 081210ia STA: A.M.2 TOP: Conversions

KEY: dimensional analysis

64 ANS: 3

The other situations are qualitative.

PTS: 2 REF: 081213ia STA: A.S.1 TOP: Analysis of Data

65 ANS: 3

TOP: Set Theory

PTS: 2 REF: 061324ia STA: A.A.31

66 ANS: 2

TOP: Slope

PTS: 2 REF: 081223ia STA: A.A.32

67 ANS: 3

$$x = \frac{-b}{2a} = \frac{-8}{2(1)} = -4. \quad y = (-4)^2 + 8(-4) + 10 = -6. \quad (-4, -6)$$

PTS: 2 REF: 011314ia STA: A.A.41
TOP: Identifying the Vertex of a Quadratic Given Equation

68 ANS: 2

$$s^3 = 8. \quad 6 \times (2 \times 2) = 24$$

$$s = 2$$

PTS: 2 REF: 081325ia STA: A.G.2 TOP: Surface Area

69 ANS: 2

TOP: Roots of Quadratics

PTS: 2 REF: 061326ia STA: A.A.28

70 ANS: 2

$$|-3 - 4| - (-3)^2 = 7 - 9 = -2$$

PTS: 2 REF: 011321ia STA: A.N.6 TOP: Evaluating Expressions

71 ANS: 3

TOP: Defining Functions

PTS: 2 REF: 081308ia STA: A.G.3

72 ANS: 2

TOP: Exponential Functions

PTS: 2 REF: 061229ia STA: A.A.9

73 ANS: 4

TOP: Theoretical Probability

PTS: 2 REF: 081303ia STA: A.S.22

74 ANS: 4

$$\frac{2x^2(x^4 - 9x^2 + 1)}{2x^2}$$

PTS: 2

REF: 081222ia

STA: A.A.16

TOP: Rational Expressions

KEY: $a > 0$

75 ANS: 2

$$W + L = 72$$

$$W - L = 12$$

$$2W = 84$$

$$W = 42$$

PTS: 2

REF: 081227ia

STA: A.A.7

TOP: Writing Linear Systems

76 ANS: 1

PTS: 2

REF: 011311ia

STA: A.A.2

TOP: Expressions

77 ANS:

$$\frac{x+2}{2} \times \frac{4(x+5)}{(x+4)(x+2)} = \frac{2(x+5)}{x+4}$$

PTS: 2

REF: 081232ia

STA: A.A.18

TOP: Multiplication and Division of Rationals

KEY: multiplication

78 ANS: 1

$$\frac{3}{4} \times 5 = \frac{15}{4} \text{ teaspoons} \times \frac{1 \text{ tablespoon}}{3 \text{ teaspoons}} = \frac{5}{4} = 1 \frac{1}{4} \text{ tablespoon}$$

PTS: 2

REF: 061228ia

STA: A.M.2

TOP: Conversions

KEY: dimensional analysis

79 ANS: 2

$$\frac{20}{3.98} = \frac{180}{x}$$

$$20x = 716.4$$

$$x = 35.82 \approx 36$$

PTS: 2

REF: 011302ia

STA: A.M.1

TOP: Using Rate

80 ANS: 1

$$\left| \frac{4(-6) + 18}{4!} \right| = \left| \frac{-6}{24} \right| = \frac{1}{4}$$

PTS: 2

REF: 081220ia

STA: A.N.6

TOP: Evaluating Expressions

81 ANS:

(1,A), (1,B), (1,C), (3,A), (3,B), (3,C), (5,A), (5,B), (5,C), (7,A), (7,B), (7,C), (9,A), (9,B), (9,C). 6

PTS: 3

REF: 011334ia

STA: A.S.19

TOP: Sample Space

82 ANS:

$$\frac{6}{25} \cdot \frac{25 - (11 + 5 + 3)}{25}$$

PTS: 2 REF: 011232ia STA: A.S.21 TOP: Experimental Probability

83 ANS: 2 PTS: 2 REF: 081311ia STA: A.A.12

TOP: Division of Powers

84 ANS: 3 PTS: 2 REF: 011204ia STA: A.G.3

TOP: Defining Functions KEY: graphs

85 ANS:

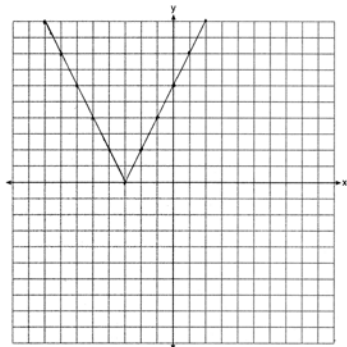

PTS: 2 REF: 011333ia STA: A.G.4 TOP: Graphing Absolute Value Functions

86 ANS: 4

$$m = \frac{-A}{B} = \frac{-4}{3}$$

PTS: 2 REF: 061319ia STA: A.A.37 TOP: Slope

87 ANS: 3 PTS: 2 REF: 081317ia STA: A.A.21

TOP: Interpreting Solutions

88 ANS: 3

$$x = \frac{-b}{2a} = \frac{-24}{2(-2)} = 6. \quad y = -2(6)^2 + 24(6) - 100 = -28$$

PTS: 2 REF: 061214ia STA: A.A.41
TOP: Identifying the Vertex of a Quadratic Given Equation

89 ANS: 4

$$375 + 155w \geq 900$$

$$155w \geq 525$$

$$w \geq 3.4$$

PTS: 2 REF: 081206ia STA: A.A.6 TOP: Modeling Inequalities

90 ANS: 4

$$5.5 \text{ g} \times \frac{4 \text{ q}}{1 \text{ g}} \times \frac{32 \text{ oz}}{1 \text{ q}} = 704 \text{ oz}$$

PTS: 2 REF: 061305ia STA: A.M.2 TOP: Conversions

KEY: dimensional analysis

91 ANS:

$$\frac{12}{20} \times \frac{8}{19} + \frac{8}{20} \times \frac{12}{19} = \frac{192}{380}. \quad 1 - P(BB) = 1 - \left(\frac{8}{20} \times \frac{7}{19} \right) = \frac{380}{380} - \frac{56}{380} = \frac{324}{380}$$

PTS: 4 REF: 081339ia STA: A.S.23 TOP: Theoretical Probability
KEY: dependent events

92 ANS: 1 PTS: 2 REF: 061209ia STA: A.G.3
TOP: Defining Functions KEY: graphs

93 ANS: 3 PTS: 2 REF: 081201ia STA: A.G.7
TOP: Solving Linear Systems

94 ANS: 1 PTS: 2 REF: 081301ia STA: A.S.12
TOP: Scatter Plots

95 ANS: 4

$$\sin D = \frac{\text{opposite}}{\text{hypotenuse}} = \frac{12}{13}$$

PTS: 2 REF: 061325ia STA: A.A.43 TOP: Using Trigonometry to Find an Angle

96 ANS: 3 PTS: 2 REF: 061225ia STA: A.A.5
TOP: Modeling Equations

97 ANS:
(C,B,T), (C,B,5), (C,N,T), (C,N,5), (C,2,T), (C,2,5), (F,B,T), (F,B,5), (F,N,T), (F,N,5), (F,2,T), (F,2,5). 1, 2.

PTS: 4 REF: 081237ia STA: A.S.19 TOP: Sample Space

98 ANS: 4 PTS: 2 REF: 011318ia STA: A.A.29
TOP: Set Theory

99 ANS: 2

$$2y + 2w = x$$

$$2w = x - 2y$$

$$w = \frac{x - 2y}{2}$$

PTS: 2 REF: 081330ia STA: A.A.23 TOP: Transforming Formulas

100 ANS: 4 PTS: 2 REF: 061320ia STA: A.G.6
TOP: Linear Inequalities

101 ANS: 1 PTS: 2 REF: 011210ia STA: A.G.6
TOP: Linear Inequalities

102 ANS: 2 PTS: 2 REF: 061314ia STA: A.S.6
TOP: Box-and-Whisker Plots

103 ANS: 4
 $A = \{1, 3, 5, 7, 9, 11, 13, 15, 17, 19\}$

PTS: 2 REF: 081306ia STA: A.A.30 TOP: Set Theory

104 ANS: 1 PTS: 2 REF: 011202ia STA: A.A.9
TOP: Exponential Functions

105 ANS: 3 PTS: 2 REF: 061208ia STA: A.A.31
TOP: Set Theory

106 ANS:

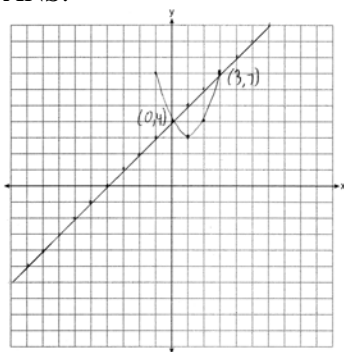

PTS: 4 REF: 011339ia STA: A.G.9 TOP: Quadratic-Linear Systems

107 ANS:

$$\frac{(10.75)(12.5) - (10.5)(12.25)}{(10.75)(12.5)} \approx 0.043$$

PTS: 3 REF: 081336ia STA: A.M.3 TOP: Error

KEY: area

108 ANS: 2

$$\cos x = \frac{\text{adjacent}}{\text{hypotenuse}} = \frac{16}{20}$$

PTS: 2 REF: 011307ia STA: A.A.42 TOP: Trigonometric Ratios

109 ANS: 1

Using $m = -\frac{A}{B}$, the slope of $2x - 3y = 9$ is $\frac{2}{3}$.

PTS: 2 REF: 011322ia STA: A.A.38 TOP: Parallel and Perpendicular Lines

110 ANS: 2 PTS: 2 REF: 011227ia STA: A.A.3

TOP: Expressions

111 ANS: 1

$$rx - st = r$$

$$rx = r + st$$

$$x = \frac{r + st}{r}$$

PTS: 2 REF: 061316ia STA: A.A.23 TOP: Transforming Formulas

112 ANS: 1

$$k = am + 3mx$$

$$k = m(a + 3x)$$

$$\frac{k}{a + 3x} = m$$

PTS: 2 REF: 061215ia STA: A.A.23 TOP: Transforming Formulas

- 113 ANS: 1 PTS: 2 REF: 061204ia STA: A.A.1
TOP: Expressions
- 114 ANS: 1

$$s = \frac{2x + t}{r}$$

$$rs = 2x + t$$

$$rs - t = 2x$$

$$\frac{rs - t}{2} = x$$
- PTS: 2 REF: 011228ia STA: A.A.23 TOP: Transforming Formulas
- 115 ANS: 3

$$\frac{120}{60} = \frac{m}{150}$$

$$m = 300$$
- PTS: 2 REF: 081202ia STA: A.M.1 TOP: Using Rate
- 116 ANS: 1 PTS: 2 REF: 011213ia STA: A.A.13
TOP: Addition and Subtraction of Polynomials KEY: addition
- 117 ANS: 2
People at a gym or football game and members of a soccer team are more biased towards sports.
- PTS: 2 REF: 061202ia STA: A.S.3 TOP: Analysis of Data
- 118 ANS: 4

$$x^2 - 2x - 15 = 0$$

$$(x + 3)(x - 5) = 0$$

$$x = -3, 5$$
- PTS: 2 REF: 081316ia STA: A.A.15 TOP: Undefined Rationals
- 119 ANS: 3 PTS: 2 REF: 081208ia STA: A.S.17
TOP: Scatter Plots
- 120 ANS: 2 PTS: 2 REF: 081318ia STA: A.A.12
TOP: Powers of Powers
- 121 ANS: 2

$$-1 \leq 3(2) + 1. \quad 2 - (-1) > 1$$

$$-1 \leq 7 \qquad 3 > 1$$
- PTS: 2 REF: 011323ia STA: A.A.40 TOP: Systems of Linear Inequalities

122 ANS: 3

$$b = 3 + d \quad (3 + d)d = 40$$

$$bd = 40 \quad d^2 + 3d - 40 = 0$$

$$(d + 8)(d - 5) = 0$$

$$d = 5$$

PTS: 2

REF: 011208ia

STA: A.A.8

TOP: Writing Quadratics

123 ANS: 1

$$\frac{(x + 5)(x + 3)}{x + 5} = x + 3$$

PTS: 2

REF: 0613071a

STA: A.A.16

TOP: Rational Expressions

KEY: $a > 0$

124 ANS:

$$V = \pi r^2 h = \pi \cdot 6.5^2 \cdot 24 = 1014\pi$$

PTS: 2

REF: 061332ia

STA: A.G.2

TOP: Volume

125 ANS: 1

$$4 + 6 + 10 + \frac{6\pi}{2} = 20 + 3\pi$$

PTS: 2

REF: 081228ia

STA: A.G.1

TOP: Compositions of Polygons and Circles

KEY: perimeter

126 ANS:

$$\frac{2}{3x} + \frac{12}{3x} = \frac{7}{x + 1}$$

$$\frac{14}{3x} = \frac{7}{x + 1}$$

$$21x = 14x + 14$$

$$7x = 14$$

$$x = 2$$

PTS: 4

REF: 061337ia

STA: A.A.26

TOP: Solving Rationals

127 ANS: 2

PTS: 2

REF: 061205ia

STA: A.S.12

TOP: Scatter Plots

128 ANS:

$$\frac{3x(x + 3)}{(x + 3)(x + 2)} \times \frac{(x - 3)(x + 2)}{(x + 3)(x - 3)} = \frac{3x}{x + 3}$$

PTS: 4

REF: 081338ia

STA: A.A.18

TOP: Multiplication and Division of Rationals

KEY: division

129 ANS: 4

$$\frac{(4x^3)^2}{2x} = \frac{16x^6}{2x} = 8x^5$$

PTS: 2 REF: 011216ia STA: A.A.12 TOP: Powers of Powers

130 ANS:

$$(-3, -5), (3, 7). \quad x^2 + 2x - 8 = 2x + 1. \quad y = 2(3) + 1 = 7$$

$$x^2 - 9 = 0 \quad y = 2(-3) + 1 = -5$$

$$x = \pm 3$$

PTS: 3 REF: 081236ia STA: A.A.11 TOP: Quadratic-Linear Systems

131 ANS:

$$\text{The turtle won by .5 minutes. Turtle: } \frac{d}{s} = \frac{100}{20} = 5. \text{ Rabbit: } \frac{d}{s} = \frac{100}{40} = 2.5 + 3 = 5.5$$

PTS: 3 REF: 011236ia STA: A.M.1 TOP: Speed

132 ANS: 1 PTS: 2 REF: 061315ia STA: A.A.15

TOP: Undefined Rationals

133 ANS: 1 PTS: 2 REF: 011303ia STA: A.A.1

TOP: Expressions

134 ANS: 3

$$x^2 - 4 = 0$$

$$(x + 2)(x - 2) = 0$$

$$x = \pm 2$$

PTS: 2 REF: 081225ia STA: A.A.15 TOP: Undefined Rationals

135 ANS: 3

$$\frac{4}{3a} - \frac{5}{2a} = \frac{8}{6a} - \frac{15}{6a} = -\frac{7}{6a}$$

PTS: 2 REF: 081328ia STA: A.A.17 TOP: Addition and Subtraction of Rationals

136 ANS: 3

$$\frac{3^6}{3^1} = 3^5$$

PTS: 2 REF: 061219ia STA: A.A.12 TOP: Division of Powers

137 ANS:

$$\text{Area of rectangle minus area of semicircle: } (5 + 6 + 5) \times 5 - \frac{\pi \times 3^2}{2} \approx 65.86$$

PTS: 4 REF: 061339ia STA: A.G.1 TOP: Compositions of Polygons and Circles

KEY: area

138 ANS: 4

$$m = \frac{-3-1}{2-5} = \frac{-4}{-3} = \frac{4}{3}$$

PTS: 2

REF: 011215ia

STA: A.A.33

TOP: Slope

139 ANS: 3

PTS: 2

REF: 061218ia

STA: A.S.20

TOP: Geometric Probability

140 ANS: 2

$$x^2 - 16x + 28 = 0$$

$$(x - 14)(x - 2) = 0$$

$$x = 14, 2$$

PTS: 2

REF: 061311ia

STA: A.A.27

TOP: Solving Quadratics by Factoring

141 ANS:

$$\frac{(5.9 \times 10.3 \times 1.7) - (6 \times 10 \times 1.5)}{5.9 \times 10.3 \times 1.7} \approx 0.129$$

PTS: 3

REF: 081235ia

STA: A.M.3

TOP: Error

KEY: volume and surface area

142 ANS:

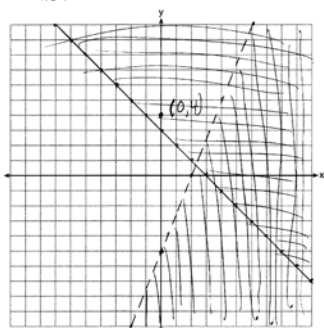

PTS: 4

REF: 081239ia

STA: A.G.7

TOP: Systems of Linear Inequalities

143 ANS: 3

PTS: 2

REF: 081230ia

STA: A.A.23

TOP: Transforming Formulas

144 ANS: 4

$$SA = 2lw + 2hw + 2lh = 2(3)(2.2) + 2(7.5)(2.2) + 2(3)(7.5) = 91.2$$

PTS: 2

REF: 081216ia

STA: A.G.2

TOP: Surface Area

145 ANS:

$$78. \cos x = \frac{6}{28}$$

$$x \approx 78$$

PTS: 3

REF: 061235ia

STA: A.A.43

TOP: Using Trigonometry to Find an Angle

146 ANS: 1

PTS: 2

REF: 011207ia

STA: A.G.9

TOP: Quadratic-Linear Systems

- 147 ANS:
 $147.75 \quad 2 \times 5.5 \times 3 + 2 \times 6.75 \times 3 + 2 \times 5.5 \times 6.75 = 147.75$
- PTS: 2 REF: 011231ia STA: A.G.2 TOP: Surface Area
- 148 ANS: 2 PTS: 2 REF: 011330ia STA: A.G.5
 TOP: Graphing Quadratic Functions
- 149 ANS: 3 PTS: 2 REF: 061318ia STA: A.G.4
 TOP: Families of Functions
- 150 ANS: 1 PTS: 2 REF: 081204ia STA: A.S.12
 TOP: Scatter Plots
- 151 ANS: 4 PTS: 2 REF: 081312ia STA: A.S.6
 TOP: Box-and-Whisker Plots
- 152 ANS: 1 PTS: 2 REF: 011301ia STA: A.S.12
 TOP: Scatter Plots
- 153 ANS: 3 PTS: 2 REF: 011309ia STA: A.G.3
 TOP: Defining Functions KEY: graphs
- 154 ANS:
 $2\sqrt{108} = 2\sqrt{36} \sqrt{3} = 12\sqrt{3}$
- PTS: 2 REF: 081332ia STA: A.N.2 TOP: Simplifying Radicals
- 155 ANS: 3
 $\sqrt{8^2 - 6^2} = \sqrt{28} = \sqrt{4} \sqrt{7} = 2\sqrt{7}$
- PTS: 2 REF: 061329ia STA: A.A.45 TOP: Pythagorean Theorem
- 156 ANS: 4
 If $m\angle C = 90$, then \overline{AB} is the hypotenuse, and the triangle is a 3-4-5 triangle.
- PTS: 2 REF: 061224ia STA: A.A.42 TOP: Trigonometric Ratios
- 157 ANS: 4
 $2(2) - (-7) = 11$
- PTS: 2 REF: 081217ia STA: A.A.39 TOP: Identifying Points on a Line
- 158 ANS: 2 PTS: 2 REF: 081305ia STA: A.A.1
 TOP: Expressions
- 159 ANS: 3
 $N = 5 + J \quad N(N - 5) = 84$
 $J = N - 5 \quad N^2 - 5N - 84 = 0$
 $NJ = 84 \quad (N - 12)(N + 7) = 0$
 $N = 12$
- PTS: 2 REF: 081304ia STA: A.A.8 TOP: Writing Quadratics
- 160 ANS: 4 PTS: 2 REF: 061321ia STA: A.A.5
 TOP: Modeling Inequalities

- 161 ANS: 2
 $A = \{4, 9, 16, 25, 36, 49, 64, 81, 100\}$
- PTS: 2 REF: 011326ia STA: A.A.30 TOP: Set Theory
- 162 ANS: 3 PTS: 2 REF: 061217ia STA: A.A.29
 TOP: Set Theory
- 163 ANS: 3 PTS: 2 REF: 011319ia STA: A.N.4
 TOP: Operations with Scientific Notation
- 164 ANS: 3
 $\tan PLM = \frac{\text{opposite}}{\text{adjacent}} = \frac{4}{3}$
- PTS: 2 REF: 011226ia STA: A.A.42 TOP: Trigonometric Ratios
- 165 ANS: 2
 $\frac{2y}{y+5} + \frac{10}{y+5} = \frac{2y+10}{y+5} = \frac{2(y+5)}{y+5} = 2$
- PTS: 2 REF: 011230ia STA: A.A.17 TOP: Addition and Subtraction of Rationals
- 166 ANS:
 $5 \times 3 \times 5 \times 3 = 225$. $1 \times 3 \times 5 \times 3 = 45$. $1 \times 2 \times 5 \times 3 = 30$
- PTS: 4 REF: 061334ia STA: A.N.7 TOP: Multiplication Counting Principle
- 167 ANS: 1
 If the area of the square is 36, a side is 6, the diameter of the circle is 6, and its radius is 3. $A = \pi r^2 = 3^2 \pi = 9\pi$
- PTS: 2 REF: 011217ia STA: A.G.1 TOP: Compositions of Polygons and Circles
 KEY: area
- 168 ANS: 3 PTS: 2 REF: 011304ia STA: A.G.7
 TOP: Solving Linear Systems
- 169 ANS: 1 PTS: 2 REF: 081319ia STA: A.N.1
 TOP: Identifying Properties
- 170 ANS: 4 PTS: 2 REF: 011222ia STA: A.A.29
 TOP: Set Theory
- 171 ANS: 3
 $\sqrt{13^2 - 7^2} = \sqrt{120}$
- PTS: 2 REF: 081323ia STA: A.A.45 TOP: Pythagorean Theorem
- 172 ANS: 3
 $5x < 55$
 $x < 11$
- PTS: 2 REF: 061211ia STA: A.A.6 TOP: Modeling Inequalities

173 ANS: 3

$$y = mx + b \quad y = \frac{3}{4}x - \frac{1}{2}$$

$$1 = \left(\frac{3}{4}\right)(2) + b \quad 4y = 3x - 2$$

$$1 = \frac{3}{2} + b$$

$$b = -\frac{1}{2}$$

PTS: 2 REF: 081219ia STA: A.A.34 TOP: Writing Linear Equations

174 ANS:

White. There are 31 white blocks, 30 red blocks and 29 blue blocks.

PTS: 2 REF: 061232ia STA: A.S.22 TOP: Theoretical Probability

175 ANS: 2 PTS: 2 REF: 081218ia STA: A.G.5

TOP: Graphing Quadratic Functions

176 ANS: 3 PTS: 2 REF: 081207ia STA: A.A.19

TOP: Factoring the Difference of Perfect Squares

177 ANS: 2

$$\frac{x+2}{2} = \frac{4}{x}$$

$$x^2 + 2x = 8$$

$$x^2 + 2x - 8 = 0$$

$$(x+4)(x-2) = 0$$

$$x = -4, 2$$

PTS: 2 REF: 061317ia STA: A.A.26 TOP: Solving Rationals

178 ANS:

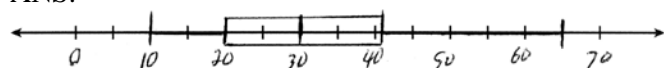

. Three scores are above 41.

PTS: 4 REF: 011337ia STA: A.S.5 TOP: Box-and-Whisker Plots

179 ANS: 2

$$\left| \frac{(2.6 \times 6.9) - (2.5 \times 6.8)}{(2.6 \times 6.9)} \right| \approx 0.052$$

PTS: 2 REF: 011209ia STA: A.M.3 TOP: Error

KEY: area

180 ANS: 4 PTS: 2 REF: 061222ia STA: A.A.40

TOP: Systems of Linear Inequalities

181 ANS: 1

$$\cos A = \frac{\text{adjacent}}{\text{hypotenuse}} = \frac{3}{5}$$

PTS: 2 REF: 081329ia STA: A.A.42 TOP: Trigonometric Ratios

182 ANS: 2 PTS: 2 REF: 081314ia STA: A.G.6

TOP: Linear Inequalities

183 ANS: 1 PTS: 2 REF: 061322ia STA: A.A.13

TOP: Addition and Subtraction of Polynomials KEY: subtraction

184 ANS: 4 PTS: 2 REF: 011229ia STA: A.S.8

TOP: Scatter Plots

185 ANS: 1 PTS: 2 REF: 061301ia STA: A.A.1

TOP: Expressions

186 ANS: 4

The transformation is a reflection in the x -axis.

PTS: 2 REF: 011206ia STA: A.G.5 TOP: Graphing Absolute Value Functions

187 ANS:

$$\frac{5}{8} \times \frac{3}{7} = \frac{15}{56} \cdot \frac{5}{8} \times \frac{4}{7} = \frac{20}{56} \cdot \frac{20}{56} + \frac{3}{8} \times \frac{2}{7} = \frac{26}{56}$$

PTS: 4 REF: 061338ia STA: A.S.23 TOP: Theoretical Probability

KEY: dependent events

188 ANS: 3 PTS: 2 REF: 011317ia STA: A.M.2

TOP: Conversions KEY: dimensional analysis

189 ANS: 1 PTS: 2 REF: 081209ia STA: A.N.1

TOP: Properties of Reals

190 ANS: 2

The other sets of data are qualitative.

PTS: 2 REF: 011211ia STA: A.S.1 TOP: Analysis of Data

191 ANS: 3

The other situations are quantitative.

PTS: 2 REF: 081313ia STA: A.S.1 TOP: Analysis of Data

192 ANS:

$$4\sqrt{75} = 4\sqrt{25} \sqrt{3} = 20\sqrt{3}$$

PTS: 2 REF: 011331ia STA: A.N.2 TOP: Simplifying Radicals

193 ANS:

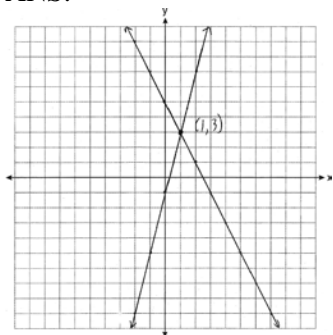

PTS: 3 REF: 011235ia STA: A.G.7 TOP: Solving Linear Systems

194 ANS: 4 PTS: 2 REF: 081322ia STA: A.G.10

TOP: Identifying the Vertex of a Quadratic Given Graph

195 ANS:

$$5 - 2\sqrt{3} + \sqrt{9}\sqrt{3} + 2(3) = 5 - 2\sqrt{3} + 3\sqrt{3} + 6 = 11 + \sqrt{3}$$

PTS: 3 REF: 061336ia STA: A.N.3 TOP: Operations with Radicals

196 ANS: 3 PTS: 2 REF: 061230ia STA: A.S.9

TOP: Frequency Histograms, Bar Graphs and Tables

197 ANS: 1 PTS: 2 REF: 061310ia STA: A.A.29

TOP: Set Theory

198 ANS: 1

$$-3x + 8 \geq 14$$

$$-3x \geq 6$$

$$x \leq -2$$

PTS: 2 REF: 081309ia STA: A.A.21 TOP: Interpreting Solutions

199 ANS: 4

$$3 + 2 - 1 = 4$$

PTS: 2 REF: 081320ia STA: A.A.6 TOP: Venn Diagrams

200 ANS: 4 PTS: 2 REF: 081229ia STA: A.S.23

TOP: Theoretical Probability KEY: independent events

201 ANS: 1 PTS: 2 REF: 061220ia STA: A.A.17

TOP: Addition and Subtraction of Rationals

202 ANS:

$$3n + 4p = 8.50 \quad 3(2.50) + 4p = 8.50$$

$$5n + 8p = 14.50 \quad 4p = 1$$

$$6n + 8p = 17 \quad p = 0.25$$

$$n = 2.50$$

PTS: 3 REF: 011335ia STA: A.A.7 TOP: Writing Linear Systems

203 ANS: 1

$$\frac{2x^2 + 10x - 28}{4x + 28} = \frac{2(x^2 + 5x - 14)}{4x + 28} = \frac{2(x+7)(x-2)}{4(x+7)} = \frac{x-2}{2}$$

PTS: 2 REF: 011327ia STA: A.A.16 TOP: Rational Expressions

KEY: $a > 0$

204 ANS: 2 PTS: 2 REF: 011201ia STA: A.A.19

TOP: Factoring the Difference of Perfect Squares

205 ANS: 2



$$y = -x + 5. \quad -x + 5 = x^2 - 25 \quad . \quad y = -(-6) + 5 = 11.$$

$$0 = x^2 + x - 30 \quad y = -5 + 5 = 0$$

$$0 = (x + 6)(x - 5)$$

$$x = -6, 5$$

PTS: 2 REF: 061213ia STA: A.A.11 TOP: Quadratic-Linear Systems

206 ANS:

$$L - S = 28 \quad . \quad 2S - 8 = S + 28$$

$$L = 2S - 8 \quad S = 36$$

$$L = S + 28 \quad L = 36 + 28 = 64$$

PTS: 3 REF: 081335ia STA: A.A.7 TOP: Writing Linear Systems

207 ANS:

$$A = P(1 + R)^t = 2000(1 + 0.035)^4 \approx 2295$$

PTS: 2 REF: 081333ia STA: A.A.9 TOP: Exponential Functions

208 ANS: 4

$$P(\text{odd}) = \frac{7 + 14 + 20}{75} = \frac{41}{75} \quad . \quad P(\text{even}) = \frac{22 + 6 + 6}{75} = \frac{34}{75} \quad . \quad P(3 \text{ or less}) = \frac{14 + 22 + 7}{75} = \frac{43}{75} \quad .$$

$$P(2 \text{ or } 4) = \frac{22 + 6}{75} = \frac{28}{75}$$

PTS: 2 REF: 011325ia STA: A.S.22 TOP: Theoretical Probability

209 ANS: 3

(2, T), (4, T), (6, T)

PTS: 2 REF: 081324ia STA: A.S.19 TOP: Sample Space

210 ANS:

$$7, 9, 11. \quad x + (x + 2) + (x + 4) = 5(x + 2) - 18$$

$$3x + 6 = 5x - 8$$

$$14 = 2x$$

$$7 = x$$

PTS: 4

REF: 011237ia

STA: A.A.6

TOP: Modeling Equations

211 ANS: 1

$$4(5 + 5) + 10\pi = 40 + 10\pi$$

PTS: 2

REF: 081326ia

STA: A.G.1

TOP: Compositions of Polygons and Circles

KEY: perimeter

212 ANS: 4

$$5 - 2x = -4x - 7$$

$$2x = -12$$

$$x = -6$$

PTS: 2

REF: 011305ia

STA: A.A.22

TOP: Solving Equations

213 ANS: 1

PTS: 2

REF: 081302ia

STA: A.A.13

TOP: Addition and Subtraction of Polynomials

KEY: addition

214 ANS:

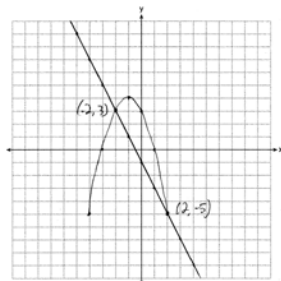

PTS: 4

REF: 081337ia

STA: A.G.9

TOP: Quadratic-Linear Systems

215 ANS: 3

$$6! + \frac{5!(3!)}{4!} - 10 = 720 + 5(6) - 10 = 740$$

PTS: 2

REF: 061309ia

STA: A.N.6

TOP: Evaluating Expressions

216 ANS:

$$\text{Carol's, by 14.9. } V_M = 5 \times 3.5 \times 7 = 122.5. \quad V_C = \pi \times 2.5^2 \times 7 \approx 137.4. \quad 137.4 - 122.5 = 14.9$$

PTS: 4

REF: 061237ia

STA: A.G.2

TOP: Volume

217 ANS:

$$54, 23. \cos A = \frac{17}{29} \cdot \sqrt{29^2 - 17^2} \approx 23$$

$$x \approx 54$$

PTS: 4 REF: 081238ia STA: A.A.43 TOP: Using Trigonometry to Find an Angle

218 ANS: 3

$$2(5) + k = 9$$

$$10 + k = 9$$

$$k = -1$$

PTS: 2 REF: 061304ia STA: A.A.39 TOP: Identifying Points on a Line

219 ANS: 2 PTS: 2 REF: 061327ia STA: A.A.36

TOP: Parallel and Perpendicular Lines

220 ANS:

$$\left| \frac{(24.2 \times 14.1) - (24 \times 14)}{(24.2 \times 14.1)} \right| = \frac{5.22}{341.22} \approx 0.015$$

PTS: 3 REF: 011336ia STA: A.M.3 TOP: Error

KEY: area

221 ANS:

(W,H,A), (W,H,S), (W,T,A), (W,T,S), (W,B,A), (W,B,S), (R,H,A), (R,H,S), (R,T,A), (R,T,S), (R,B,A), (R,B,S).
8, 3

PTS: 4 REF: 011238ia STA: A.S.19 TOP: Sample Space

222 ANS: 1

$$x^2 - 5x + 3 = x - 6 \quad y = 3 - 6 = -3 \quad (3, -3)$$

$$x^2 - 6x + 9 = 0$$

$$(x - 3)^2 = 0$$

$$x = 3$$

PTS: 2 REF: 061330ia STA: A.G.9 TOP: Quadratic-Linear Systems

223 ANS:

$$\frac{5.4 \text{ miles}}{\text{hour}} \times \frac{5280 \text{ feet}}{\text{mile}} \times \frac{1 \text{ hour}}{60 \text{ min}} = \frac{475.2 \text{ ft}}{\text{min}}$$

PTS: 2 REF: 081331ia STA: A.M.2 TOP: Conversions

KEY: dimensional analysis

224 ANS:

 $26 \times 25 \times 24 \times 23 = 358,800.$ $10^6 = 1,000,000.$ Use the numeric password since there are over 500,000 employees

PTS: 4 REF: 061239ia STA: A.N.8 TOP: Permutations

225 ANS:

$$\frac{x-1}{x+2} \cdot \frac{x^2-1}{x^2+3x+2} = \frac{(x+1)(x-1)}{(x+2)(x+1)}$$

PTS: 2 REF: 011233ia STA: A.A.16 TOP: Rational Expressions

KEY: $a > 0$

226 ANS:

$$800 - (895)(0.75)(1.08) = 75.05$$

PTS: 3 REF: 081334ia STA: A.N.5 TOP: Percents

227 ANS: 2 PTS: 2 REF: 011212ia STA: A.S.23

TOP: Theoretical Probability KEY: independent events

228 ANS: 3

Due to lack of specificity in the wording, this 13th question was removed from the June, 2013 Regents Exam.

PTS: 2 REF: 061313ia STA: A.S.2 TOP: Analysis of Data

229 ANS:

$$2(x-4) \geq \frac{1}{2}(5-3x)$$

$$4(x-4) \geq 5-3x$$

$$4x-16 \geq 5-3x$$

$$7x \geq 21$$

$$x \geq 3$$

PTS: 3 REF: 011234ia STA: A.A.24 TOP: Solving Inequalities

230 ANS:

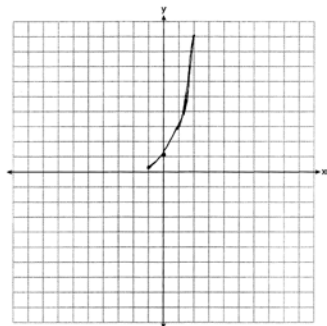

PTS: 2 REF: 081233ia STA: A.G.4 TOP: Graphing Exponential Functions

231 ANS: 3 PTS: 2 REF: 011220ia STA: A.S.6

TOP: Box-and-Whisker Plots

232 ANS:

$$6.56 \times 10^{-2}$$

PTS: 2 REF: 081231ia STA: A.N.4 TOP: Operations with Scientific Notation

233 ANS:
3, 0, 20. $15 - 12 = 3$. $12 - 12 = 0$

PTS: 3 REF: 081234ia STA: A.S.9
TOP: Frequency Histograms, Bar Graphs and Tables

234 ANS: 2
To determine student opinion, survey the widest range of students.

PTS: 2 REF: 011313ia STA: A.S.3 TOP: Analysis of Data

Integrated Algebra Regents at Random Answer Section

- 235 ANS: 4 PTS: 2 REF: 011412ia STA: A.A.14
TOP: Division of Polynomials
- 236 ANS:
cap-jacket: TT, TR, TW, BB, BR, BW, RB, RR, RW, GB, GR, GW, 10, 6.

PTS: 4 REF: 011439ia STA: A.S.19 TOP: Sample Space
- 237 ANS: 2
 $y = \frac{1}{2}x - 2$

PTS: 2 REF: 011409ia STA: A.A.37 TOP: Slope
- 238 ANS: 3
The other situations are qualitative.

PTS: 2 REF: 011414ia STA: A.S.1 TOP: Analysis of Data
- 239 ANS: 3 PTS: 2 REF: 011408ia STA: A.S.6
TOP: Box-and-Whisker Plots
- 240 ANS: 4 PTS: 2 REF: 011401ia STA: A.A.3
TOP: Expressions
- 241 ANS:
 $\frac{\sqrt{84}}{2\sqrt{3}} = \frac{\sqrt{4}\sqrt{21}}{2\sqrt{3}} = \sqrt{\frac{21}{3}} = \sqrt{7}$

PTS: 2 REF: 011431ia STA: A.N.3 TOP: Operations with Radicals
KEY: division
- 242 ANS: 4
 $2x^2 - 8x = 0$
 $2x(x - 4) = 0$
 $x = 0, 4$

PTS: 2 REF: 011427ia STA: A.A.28 TOP: Roots of Quadratics
- 243 ANS: 1
 $y = mx + b$
 $-8 = (3)(-2) + b$
 $b = -2$

PTS: 2 REF: 011406ia STA: A.A.34 TOP: Writing Linear Equations

244 ANS: 1

$$abx - 5 = 0$$

$$abx = 5$$

$$x = \frac{5}{ab}$$

PTS: 2

REF: 011425ia

STA: A.A.23

TOP: Transforming Formulas

245 ANS: 2

$$d = st = 45 \times 3 = 135 \text{ miles. } t = \frac{d}{s} = \frac{135}{55} \approx 2.5 \text{ hours}$$

PTS: 2

REF: 011419ia

STA: A.M.1

TOP: Speed

246 ANS: 1

PTS: 2

REF: 011418ia

STA: A.A.24

TOP: Solving Inequalities

247 ANS: 3

$$y > 2x - 3$$

PTS: 2

REF: 011422ia

STA: A.G.6

TOP: Linear Inequalities

248 ANS: 3

PTS: 2

REF: 011404ia

STA: A.S.3

TOP: Analysis of Data

249 ANS: 3

$$\frac{2n}{5} + \frac{3n}{2} = \frac{4n + 15n}{10} = \frac{19n}{10}$$

PTS: 2

REF: 011420ia

STA: A.A.17

TOP: Addition and Subtraction of Rationals

250 ANS: 3

$$\frac{x^2 - 25}{x^2 - x - 20} = \frac{(x+5)(x-5)}{(x+4)(x-5)} = \frac{x+5}{x+4}$$

PTS: 2

REF: 011424ia

STA: A.A.16

TOP: Rational Expressions

KEY: $a > 0$

251 ANS:

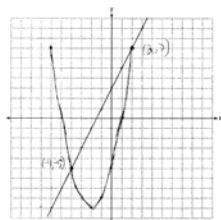

PTS: 4

REF: 011437ia

STA: A.G.9

TOP: Quadratic-Linear Systems

252 ANS:

$$\tan 38 = \frac{opp}{80}$$

$$opp = 80 \tan 38 \approx 62.5$$

PTS: 3

REF: 011436ia

STA: A.A.44

TOP: Using Trigonometry to Find a Side

253 ANS: 3 PTS: 2 REF: 011413ia STA: A.A.4
TOP: Modeling Equations

254 ANS:
If there are 31 students, the 16th student's time represents the median. The 16th time is in the 41-80 interval on the cumulative frequency table and the 71-80 interval on the related frequency table.

PTS: 2 REF: 011432ia STA: A.S.9
TOP: Frequency Histograms, Bar Graphs and Tables

255 ANS: 2
 $2x + 3y = 7$
 $3x + 3y = 9$
 $x = 2$

PTS: 2 REF: 011410ia STA: A.A.10 TOP: Solving Linear Systems

256 ANS: 4
 $x + x + 2 + x + 4 = 3x + 6$

PTS: 2 REF: 011430ia STA: A.A.1 TOP: Expressions

257 ANS: 3
 $2(4)^0 + (4)! = 2 + 24 = 26$

PTS: 2 REF: 011421ia STA: A.N.6 TOP: Evaluating Expressions

258 ANS:

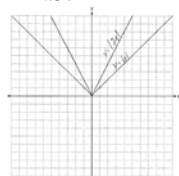

. Graph becomes narrower as the coefficient increases.

PTS: 3 REF: 011434ia STA: A.G.5 TOP: Graphing Absolute Value Functions

259 ANS: 4 PTS: 2 REF: 011423ia STA: A.G.4
TOP: Graphing Exponential Functions

260 ANS: 4 PTS: 2 REF: 011429ia STA: A.A.13
TOP: Addition and Subtraction of Polynomials KEY: subtraction

261 ANS: 2 PTS: 2 REF: 011415ia STA: A.S.21
TOP: Experimental Probability

262 ANS: 2
 $\sqrt{48^2 + 40^2} = \sqrt{2304 + 1600} = \sqrt{3904} \approx 62$

PTS: 2 REF: 011417ia STA: A.A.45 TOP: Pythagorean Theorem

263 ANS:
 $1000(1.03)^5 \approx 1159.27$

PTS: 3 REF: 011433ia STA: A.A.9 TOP: Exponential Functions

264 ANS: 3 PTS: 2 REF: 011428ia STA: A.N.1
TOP: Properties of Reals

- 265 ANS: 1 PTS: 2 REF: 011403ia STA: A.A.5
TOP: Modeling Inequalities
- 266 ANS: 2
 $6^2 - \frac{(3)^2\pi}{2}$
- PTS: 2 REF: 011407ia STA: A.G.1 TOP: Compositions of Polygons and Circles
KEY: area
- 267 ANS: 3
 $3mn(m + 4n)$
- PTS: 2 REF: 011402ia STA: A.A.20 TOP: Factoring Polynomials
- 268 ANS: 4
An element of the domain, 1, is paired with two different elements of the range, 1 and -1.
- PTS: 2 REF: 011405ia STA: A.G.3 TOP: Defining Functions
KEY: ordered pairs
- 269 ANS:
 $\frac{6(5.2)^2 - 6(5)^2}{6(5.2)^2} \approx .075$
- PTS: 3 REF: 011435ia STA: A.M.3 TOP: Error
KEY: volume and surface area
- 270 ANS: 1
 $x = \frac{-b}{2a} = \frac{-6}{2(3)} = -1. \quad y = 3(-1)^2 + 6(-1) + 1 = -2$
- PTS: 2 REF: 011416ia STA: A.A.41
TOP: Identifying the Vertex of a Quadratic Given Equation
- 271 ANS: 4 PTS: 2 REF: 011426ia STA: A.A.30
TOP: Set Theory

Integrated Algebra Regents at Random Answer Section

272 ANS: 4 PTS: 2 REF: 060805ia STA: A.S.12

TOP: Scatter Plots

273 ANS: 4

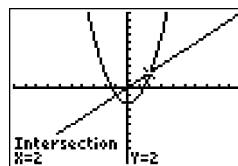

$x^2 - 2 = x$ Since $y = x$, the solutions are $(2, 2)$ and $(-1, -1)$.

$$x^2 - x - 2 = 0$$

$$(x - 2)(x + 1) = 0$$

$$x = 2 \text{ or } -1$$

PTS: 2 REF: 060810ia STA: A.A.11 TOP: Quadratic-Linear Systems

274 ANS:

$$0 \leq t \leq 40$$

PTS: 2 REF: 060833ia STA: A.A.31 TOP: Set Theory

275 ANS: 1

$m = \frac{3-0}{0-2} = -\frac{3}{2}$. Using the given y-intercept $(0, 3)$ to write the equation of the line $y = -\frac{3}{2}x + 3$.

PTS: 2 REF: fall0713ia STA: A.A.35 TOP: Writing Linear Equations

276 ANS: 1

$30^2 + 40^2 = c^2$. 30, 40, 50 is a multiple of 3, 4, 5.

$$2500 = c^2$$

$$50 = c$$

PTS: 2 REF: fall0711ia STA: A.A.45 TOP: Pythagorean Theorem

277 ANS:

$$7. 15x + 22 \geq 120$$

$$x \geq 6.\overline{53}$$

PTS: 3 REF: fall0735ia STA: A.A.6 TOP: Modeling Inequalities

278 ANS: 3

$$x^2 - 6x = 0$$

$$x(x - 6) = 0$$

$$x = 0 \text{ or } x = 6$$

PTS: 2 REF: 080921ia STA: A.A.27 TOP: Solving Quadratics by Factoring

279 ANS: 1 PTS: 2 REF: 080803ia STA: A.A.4

TOP: Modeling Inequalities

280 ANS: 2

The slope of the inequality is $-\frac{1}{2}$.

PTS: 2 REF: fall0720ia STA: A.G.6 TOP: Linear Inequalities

281 ANS: 2

$$\frac{6}{4a} - \frac{2}{3a} = \frac{18a - 8a}{12a^2} = \frac{10a}{12a^2} = \frac{5}{6a}$$

PTS: 2 REF: 060929ia STA: A.A.17 TOP: Addition and Subtraction of Rationals

282 ANS: 3

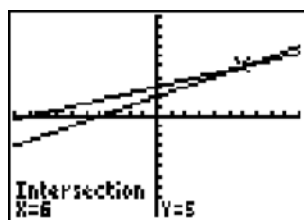

$$\frac{k+4}{2} = \frac{k+9}{3}$$

$$3(k+4) = 2(k+9)$$

$$3k + 12 = 2k + 18$$

$$k = 6$$

PTS: 2 REF: 010906ia STA: A.A.26 TOP: Solving Rationals

283 ANS: 4 PTS: 2 REF: fall0717ia STA: A.G.4

TOP: Families of Functions

284 ANS: 4

$$P(G \text{ or } W) = \frac{4}{8}, P(G \text{ or } B) = \frac{3}{8}, P(Y \text{ or } B) = \frac{4}{8}, P(Y \text{ or } G) = \frac{5}{8}$$

PTS: 2 REF: 060802ia STA: A.S.22 TOP: Geometric Probability

285 ANS: 3

The other situations are quantitative.

PTS: 2 REF: 060905ia STA: A.S.1 TOP: Analysis of Data

286 ANS: 4 PTS: 2 REF: fall0704ia STA: A.A.29

TOP: Set Theory

287 ANS:

$$36 - 9\pi. \quad 15.6. \quad \text{Area of square} - \text{area of 4 quarter circles. } (3 + 3)^2 - 3^2\pi = 36 - 9\pi$$

PTS: 2 REF: 060832ia STA: A.G.1 TOP: Compositions of Polygons and Circles

KEY: area

288 ANS: 1 PTS: 2 REF: fall0723ia STA: A.M.3

TOP: Error KEY: area

289 ANS: 1

$$y = mx + b$$

$$-6 = (-3)(4) + b$$

$$b = 6$$

PTS: 2 REF: 060922ia STA: A.A.34 TOP: Writing Linear Equations

290 ANS: 3 PTS: 2 REF: 060825ia STA: A.A.45

TOP: Pythagorean Theorem

291 ANS: 4

Surveying persons leaving a football game about a sports budget contains the most bias.

PTS: 2 REF: 080910ia STA: A.S.3 TOP: Analysis of Data

292 ANS: 3

The other situations are quantitative.

PTS: 2 REF: 060819ia STA: A.S.1 TOP: Analysis of Data

293 ANS: 4 PTS: 2 REF: 060906ia STA: A.A.4

TOP: Modeling Inequalities

294 ANS: 3

$$b = 42 - r \quad r = 2b + 3$$

$$r = 2b + 3 \quad r = 2(42 - r) + 3$$

$$r = 84 - 2r + 3$$

$$3r = 87$$

$$r = 29$$

PTS: 2 REF: 060812ia STA: A.A.7 TOP: Writing Linear Systems

295 ANS:

$$60 - 42\sqrt{5} \cdot 3\sqrt{20}(2\sqrt{5} - 7) = 6\sqrt{100} - 21\sqrt{20} = 60 - 21\sqrt{4}\sqrt{5} = 60 - 42\sqrt{5}$$

PTS: 3 REF: 080834ia STA: A.N.3 TOP: Operations with Radicals

KEY: multiplication

296 ANS: 2 PTS: 2 REF: 080823ia STA: A.A.32

TOP: Slope

297 ANS: 3

$$\frac{(2x^3)(8x^5)}{4x^6} = \frac{16x^8}{4x^6} = 4x^2$$

PTS: 2 REF: fall0703ia STA: A.A.12 TOP: Division of Powers

298 ANS:

$$y = \frac{2}{5}x + 2. \quad m = \frac{4-0}{5-(-5)} = \frac{2}{5}. \quad y = mx + b \quad .$$

$$4 = \frac{2}{5}(5) + b$$

$$b = 2$$

PTS: 3 REF: 080836ia STA: A.A.35 TOP: Writing Linear Equations

299 ANS:

$$\frac{1}{6}, 16.67\%, \$13.50. \quad \frac{18-15}{18} = \frac{1}{6}. \quad 18 \times 0.75 = 13.5$$

PTS: 3 REF: 060835ia STA: A.N.5 TOP: Percents

300 ANS: 2

$$\frac{2x^2 - 12x}{x-6} = \frac{2x(x-6)}{x-6} = 2x$$

PTS: 2 REF: 060824ia STA: A.A.16 TOP: Rational Expressions

KEY: $a > 0$

301 ANS: 1

$$8^2 + 15^2 = c^2$$

$$c^2 = 289$$

$$c = 17$$

PTS: 2 REF: 080906ia STA: A.A.45 TOP: Pythagorean Theorem

302 ANS: 3 PTS: 2 REF: fall0705ia STA: A.N.1

TOP: Identifying Properties

303 ANS:

$$4x(x+3)(x-3). \quad 4x^3 - 36x = 4x(x^2 - 9) = 4x(x+3)(x-3)$$

PTS: 2 REF: 060932ia STA: A.A.19

TOP: Factoring the Difference of Perfect Squares

304 ANS: 2 PTS: 2 REF: fall0701ia STA: A.S.7

TOP: Scatter Plots

305 ANS: 2 PTS: 2 REF: 080810ia STA: A.A.36

TOP: Parallel and Perpendicular Lines

306 ANS: 2 PTS: 2 REF: 010915ia STA: A.A.5

TOP: Modeling Equations

307 ANS: 1

$$m = \frac{4 - (-4)}{-5 - 15} = -\frac{2}{5}$$

PTS: 2 REF: 080915ia STA: A.A.33 TOP: Slope

308 ANS: 3

$$m = \frac{1 - (-4)}{-6 - 4} = -\frac{1}{2}$$

PTS: 2

REF: 060820ia

STA: A.A.33

TOP: Slope

309 ANS: 4

$$y = mx + b$$

$$-1 = (2)(3) + b$$

$$b = -7$$

PTS: 2

REF: 080927ia

STA: A.A.34

TOP: Writing Linear Equations

310 ANS: 4

PTS: 2

REF: fall0730ia

STA: A.G.3

TOP: Defining Functions

KEY: graphs

311 ANS: 4

The mean is $80.\bar{6}$, the median is 84.5 and the mode is 87.

PTS: 2

REF: 010907ia

STA: A.S.4

TOP: Central Tendency

312 ANS: 2

PTS: 2

REF: 080802ia

STA: A.N.1

TOP: Identifying Properties

313 ANS: 2

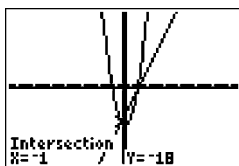

$$x^2 - x - 20 = 3x - 15 \quad y = 3x - 15$$

$$x^2 - 4x - 6 = 0 \quad = 3(-1) - 15$$

$$(x - 5)(x + 1) = 0 \quad = -18$$

$$x = 5 \text{ or } -1$$

PTS: 2

REF: 010922ia

STA: A.A.11

TOP: Quadratic-Linear Systems

314 ANS: 1

$$\frac{2}{x} - 3 = \frac{26}{x}$$

$$-3 = \frac{24}{x}$$

$$x = -8$$

PTS: 2

REF: 010918ia

STA: A.A.26

TOP: Solving Rationals

315 ANS: 4

PTS: 2

REF: 080825ia

STA: A.A.40

TOP: Systems of Linear Inequalities

316 ANS: 4

PTS: 2

REF: 010929ia

STA: A.S.6

TOP: Box-and-Whisker Plots

317 ANS: 4

$$\frac{(d \times 3) + (2 \times 2d)}{2 \times 3} = \frac{3d + 4d}{6} = \frac{7d}{6}$$

PTS: 2 REF: fall0727ia STA: A.A.17 TOP: Addition and Subtraction of Rationals

318 ANS: 4

$$P(O) = \frac{3}{6}, P(E) = \frac{3}{6}, P(< 6) = \frac{5}{6}, P(> 4) = \frac{2}{6}$$

PTS: 2 REF: 010903ia STA: A.S.22 TOP: Theoretical Probability

319 ANS: 4

$$\frac{344 \text{ m}}{\text{sec}} \times \frac{60 \text{ sec}}{1 \text{ min}} \times \frac{60 \text{ min}}{1 \text{ hr}} = 1,238,400 \frac{\text{m}}{\text{hr}}$$

PTS: 2 REF: 060911ia STA: A.M.2 TOP: Conversions

KEY: dimensional analysis

320 ANS:

$$(-2, 5). \quad 3x + 2y = 4 \quad 12x + 8y = 16. \quad 3x + 2y = 4$$

$$4x + 3y = 7 \quad 12x + 9y = 21 \quad 3x + 2(5) = 4$$

$$y = 5 \quad 3x = -6$$

$$x = -2$$

PTS: 4 REF: 010937ia STA: A.A.10 TOP: Solving Linear Systems

321 ANS: 1

To determine student interest, survey the widest range of students.

PTS: 2 REF: 060803ia STA: A.S.3 TOP: Analysis of Data

322 ANS: 4

$$SA = 2lw + 2hw + 2lh = 2(3)(1.5) + 2(2)(1.5) + 2(3)(2) = 27$$

PTS: 2 REF: 060827ia STA: A.G.2 TOP: Surface Area

323 ANS: 4 PTS: 2 REF: 060829ia STA: A.G.5

TOP: Graphing Quadratic Functions

324 ANS:

$$6, -2. \quad \frac{x+1}{x} = \frac{-7}{x-12}$$

$$(x+1)(x-12) = -7x$$

$$x^2 - 11x - 12 = -7x$$

$$x^2 - 4x - 12 = 0$$

$$(x-6)(x+2) = 0$$

$$x = 6 \text{ or } -2$$

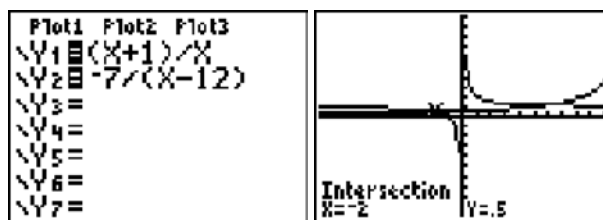

PTS: 4 REF: fall0739ia STA: A.A.26 TOP: Solving Rationals

325 ANS: 4 PTS: 2 REF: 010927ia STA: A.N.4

TOP: Operations with Scientific Notation

326 ANS: 3

$$5x + 2y = 48$$

$$3x + 2y = 32$$

$$2x = 16$$

$$x = 8$$

PTS: 2 REF: fall0708ia STA: A.A.10 TOP: Solving Linear Systems

327 ANS: 1

$$\frac{(2x \times 6) + (3 \times x)}{3 \times 6} = 5$$

$$\frac{12x + 3x}{18} = 5$$

$$15x = 90$$

$$x = 6$$

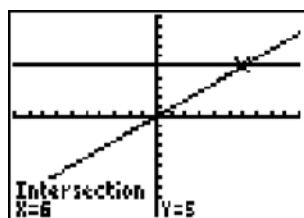

PTS: 2 REF: 060907ia STA: A.A.25

TOP: Solving Equations with Fractional Expressions

328 ANS: 2 PTS: 2 REF: 060904ia STA: A.A.1

TOP: Expressions

329 ANS: 1 PTS: 2 REF: 060804ia STA: A.A.19

TOP: Factoring the Difference of Perfect Squares

330 ANS: 3 PTS: 2 REF: 080907ia STA: A.S.20
TOP: Geometric Probability

331 ANS: 4

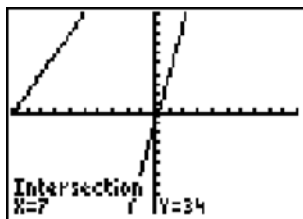

$$5p - 1 = 2p + 20$$

$$3p = 21$$

$$p = 7$$

PTS: 2 REF: 080801ia STA: A.A.22 TOP: Solving Equations
332 ANS: 4

$$16^2 + b^2 = 34^2$$

$$b^2 = 900$$

$$b = 30$$

PTS: 2 REF: 080809ia STA: A.A.45 TOP: Pythagorean Theorem
333 ANS: 2

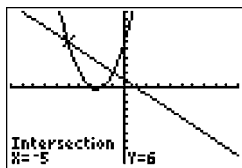

$$x^2 + 5x + 6 = -x + 1 \quad y = -x + 1$$

$$x^2 + 6x + 5 = 0 \quad = -(-5) + 1$$

$$(x + 5)(x + 1) = 0 \quad = 6$$

$$x = -5 \text{ or } -1$$

PTS: 2 REF: 080812ia STA: A.A.11 TOP: Quadratic-Linear Systems
334 ANS: 3

$$500(1 + 0.06)^3 \approx 596$$

PTS: 2 REF: 080929ia STA: A.A.9 TOP: Exponential Functions
335 ANS: 2 PTS: 2 REF: 060923ia STA: A.A.13
TOP: Addition and Subtraction of Polynomials KEY: subtraction

336 ANS: 2 PTS: 2 REF: 060821ia STA: A.A.5
TOP: Modeling Inequalities

337 ANS: 4



PTS: 2 REF: 080822ia STA: A.S.8 TOP: Scatter Plots

338 ANS: 2

$$\frac{3}{5}(x + 2) = x - 4$$

$$3(x + 2) = 5(x - 4)$$

$$3x + 6 = 5x - 20$$

$$26 = 2x$$

$$x = 13$$

PTS: 2 REF: 080909ia STA: A.A.25
TOP: Solving Equations with Fractional Expressions

339 ANS: 3 PTS: 2 REF: 080925ia STA: A.G.4
TOP: Identifying the Equation of a Graph

340 ANS: 3 PTS: 2 REF: 060926ia STA: A.N.1
TOP: Properties of Reals

341 ANS: 3 PTS: 2 REF: fall0710ia STA: A.A.31
TOP: Set Theory

342 ANS:

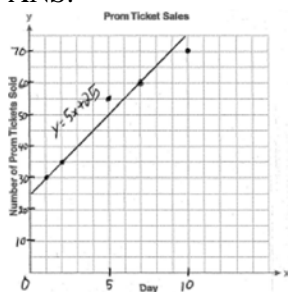

PTS: 3 REF: 060936ia STA: A.S.8 TOP: Scatter Plots

343 ANS:

(S,S), (S,K), (S,D), (K,S), (K,K), (K,D), (D,S), (D,K), (D,D), $\frac{4}{9}$

PTS: 3 REF: fall0736ia STA: A.S.19 TOP: Sample Space

344 ANS: 1 PTS: 2 REF: 080902ia STA: A.A.19
TOP: Factoring the Difference of Perfect Squares

345 ANS: 3

The number of correct answers on a test causes the test score.

PTS: 2

REF: 080908ia

STA: A.S.13

TOP: Analysis of Data

346 ANS: 4

$$\frac{5}{45} = \frac{8}{x}$$

$$5x = 360$$

$$x = 72$$

PTS: 2

REF: 060901ia

STA: A.M.1

TOP: Speed

347 ANS: 4

$$\frac{\text{distance}}{\text{time}} = \frac{24}{6} = 4$$

PTS: 2

REF: 010902ia

STA: A.M.1

TOP: Speed

348 ANS: 4

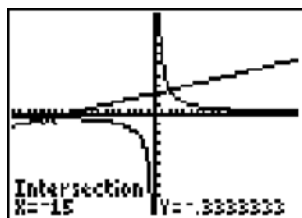

$$\frac{5}{x} = \frac{x+13}{6}$$

$$x^2 + 13x = 30$$

$$x^2 + 13x - 30 = 0$$

$$(x+15)(x-2) = 0$$

$$x = -15 \text{ or } 2$$

PTS: 2

REF: 060826ia

STA: A.A.26

TOP: Solving Rationals

349 ANS: 4

PTS: 2

REF: 060930ia

STA: A.A.29

TOP: Set Theory

350 ANS:

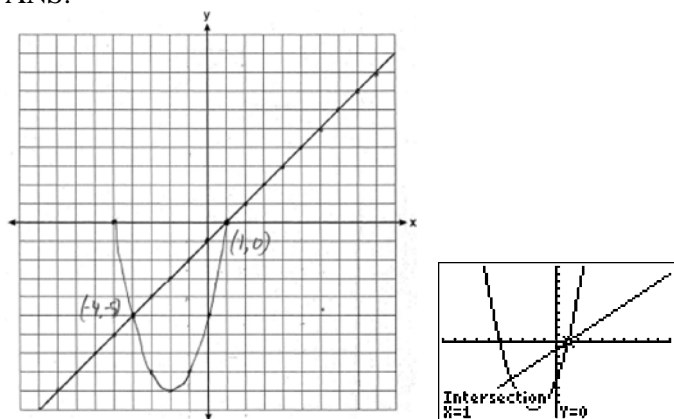

PTS: 4 REF: 080839ia STA: A.G.9 TOP: Quadratic-Linear Systems

351 ANS: 1 PTS: 2 REF: 080911ia STA: A.A.36

TOP: Parallel and Perpendicular Lines

352 ANS: 3

The value of the third quartile is the last vertical line of the box.

PTS: 2 REF: 080818ia STA: A.S.6 TOP: Box-and-Whisker Plots

353 ANS:

$$30.4\%; \text{ no, } 23.3\%. \quad \frac{7.50 - 5.75}{5.75} = 30.4\%. \quad \frac{7.50 - 5.75}{7.50} = 23.3\%$$

PTS: 3 REF: 080935ia STA: A.N.5 TOP: Percents

354 ANS: 3

$$\cos 30 = \frac{x}{24}$$

$$x \approx 21$$

PTS: 2 REF: 010912ia STA: A.A.44 TOP: Using Trigonometry to Find a Side

355 ANS: 3 PTS: 2 REF: 060919ia STA: A.G.3

TOP: Defining Functions KEY: graphs

356 ANS:

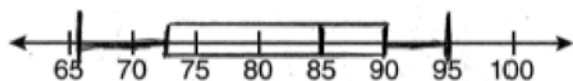

PTS: 4 REF: 080939ia STA: A.S.5 TOP: Box-and-Whisker Plots

357 ANS:

$$d = 6.25h, 250. \quad d = 6.25(40) = 250$$

PTS: 2 REF: 010933ia STA: A.N.5 TOP: Direct Variation

358 ANS:

$$\frac{3k^2m^6}{4}$$

PTS: 2 REF: 010932ia STA: A.A.12 TOP: Division of Powers

359 ANS: 2

$$\frac{3}{2x} + \frac{4}{3x} = \frac{9x + 8x}{6x^2} = \frac{17x}{6x^2} = \frac{17}{6x}$$

PTS: 2 REF: 080917ia STA: A.A.17 TOP: Addition and Subtraction of Rationals

360 ANS: 4

$$\begin{aligned}x^2 - 7x + 6 &= 0 \\(x - 6)(x - 1) &= 0 \\x = 6 \quad x = 1\end{aligned}$$

PTS: 2 REF: 060902ia STA: A.A.28 TOP: Roots of Quadratics

361 ANS:

$$50, 1.5, 10. \quad \frac{\text{distance}}{\text{time}} = \frac{60}{1.2} = 50. \quad \frac{\text{distance}}{\text{time}} = \frac{60}{40} = 1.5. \quad \text{speed} \times \text{time} = 55 \times 2 = 110. \quad 120 - 110 = 10$$

PTS: 3 REF: fall0734ia STA: A.M.1 TOP: Speed

362 ANS:

$$\frac{3}{8} \cdot P(s_1 < 4) \times P(s_2 = \text{back}) = \frac{3}{4} \times \frac{1}{2} = \frac{3}{8}$$

PTS: 2 REF: 080832ia STA: A.S.23 TOP: Geometric Probability

363 ANS: 1

The slope of $y = 3 - 2x$ is -2 . Using $m = -\frac{A}{B}$, the slope of $4x + 2y = 5$ is $-\frac{4}{2} = -2$.

PTS: 2 REF: 010926ia STA: A.A.38 TOP: Parallel and Perpendicular Lines

364 ANS: 3

$$m = \frac{4 - 10}{3 - (-6)} = -\frac{2}{3}$$

PTS: 2 REF: fall0716ia STA: A.A.33 TOP: Slope

365 ANS: 4

$$25(x - 3) = 25x - 75$$

PTS: 2 REF: 060823ia STA: A.A.1 TOP: Expressions

366 ANS: 3

$$|-5(5) + 12| = |-13| = 13$$

PTS: 2 REF: 080923ia STA: A.N.6 TOP: Evaluating Expressions

367 ANS:

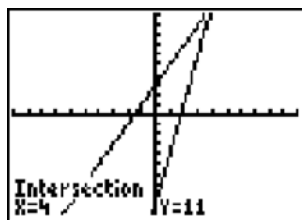

4. $3 + 2g = 5g - 9$

$12 = 3g$

$g = 4$

PTS: 2

REF: fall0732ia

STA: A.A.22

TOP: Solving Equations

368 ANS:

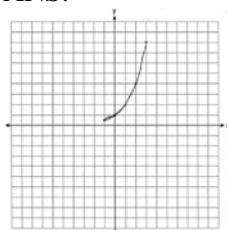
. The graph will never intersect the x -axis as $2^x > 0$ for all values of x .

PTS: 3

REF: 080835ia

STA: A.G.4

TOP: Graphing Exponential Functions

369 ANS:

5,112. $(12 \times 30 \times 16) - (6 \times 12 \times 9) = 5112$

PTS: 2

REF: 080932ia

STA: A.G.2

TOP: Volume

370 ANS: 1

PTS: 2

REF: 060920ia

STA: A.G.6

TOP: Linear Inequalities

371 ANS:

$$\frac{38}{\pi}, 2. \quad V = \pi r^2 h \quad . \quad \frac{36}{\left(\frac{38}{\pi}\right)} \approx 2.97. \text{ Three cans will not fit. The maximum number is 2.}$$

$$342 = \pi \left(\frac{6}{2}\right)^2 h$$

$$\frac{342}{9\pi} = h$$

$$\frac{38}{\pi} = h$$

PTS: 3

REF: 010936ia

STA: A.G.2

TOP: Volume

372 ANS: 2

$$\frac{6}{5x} - \frac{2}{3x} = \frac{18x - 10x}{15x^2} = \frac{8x}{15x^2} = \frac{8}{15x}$$

PTS: 2

REF: 010921ia

STA: A.A.17

TOP: Addition and Subtraction of Rationals

373 ANS: 2

The events are not mutually exclusive: $P(\text{prime}) = \frac{3}{6}$, $P(\text{even}) = \frac{3}{6}$, $P(\text{prime AND even}) = \frac{1}{6}$

$$P(\text{prime OR even}) = \frac{3}{6} + \frac{3}{6} - \frac{1}{6} = \frac{5}{6}$$

PTS: 2 REF: 080830ia STA: A.S.23 TOP: Theoretical Probability

KEY: not mutually exclusive events

374 ANS: 3

$$a + ar = b + r$$

$$a(1 + r) = b + r$$

$$a = \frac{b + r}{1 + r}$$

PTS: 2 REF: 060913ia STA: A.A.23 TOP: Transforming Formulas

375 ANS: 2

The set of integers greater than -2 and less than 6 is $\{-1, 0, 1, 2, 3, 4, 5\}$. The subset of this set that is the positive factors of 5 is $\{1, 5\}$. The complement of this subset is $\{-1, 0, 2, 3, 4\}$.

PTS: 2 REF: 060818ia STA: A.A.30 TOP: Set Theory

376 ANS: 3

$$3ax + b = c$$

$$3ax = c - b$$

$$x = \frac{c - b}{3a}$$

PTS: 2 REF: 080808ia STA: A.A.23 TOP: Transforming Formulas

377 ANS: 2

$$3c + 4m = 12.50$$

$$3c + 2m = 8.50$$

$$2m = 4.00$$

$$m = 2.00$$

PTS: 2 REF: 060806ia STA: A.A.7 TOP: Writing Linear Systems

378 ANS: 1

PTS: 2

REF: 010905ia

STA: A.G.4

TOP: Families of Functions

379 ANS: 4

PTS: 2

REF: fall0729ia

STA: A.A.2

TOP: Expressions

380 ANS: 4

PTS: 2

REF: 010908ia

STA: A.A.9

TOP: Exponential Functions

381 ANS:

Greg's rate of 5.5 is faster than Dave's rate of 5.3. $\frac{\text{distance}}{\text{time}} = \frac{11}{2} = 5.5$. $\frac{16}{3} = 5.\bar{3}$

PTS: 3 REF: 080936ia STA: A.M.1 TOP: Speed

382 ANS:

$$10 + 2d \geq 75, 33. \quad 10 + 2d \geq 75$$

$$d \geq 32.5$$

PTS: 3

REF: 060834ia

STA: A.A.6

TOP: Modeling Inequalities

383 ANS: 3

PTS: 2

REF: fall0706ia

STA: A.A.19

TOP: Factoring the Difference of Perfect Squares

384 ANS: 3

The value of the upper quartile is the last vertical line of the box.

PTS: 2

REF: 060915ia

STA: A.S.6

TOP: Box-and-Whisker Plots

385 ANS: 1

$$\frac{1}{8} \times \frac{1}{8} = \frac{1}{64}$$

PTS: 2

REF: 010928ia

STA: A.S.23

TOP: Geometric Probability

386 ANS:

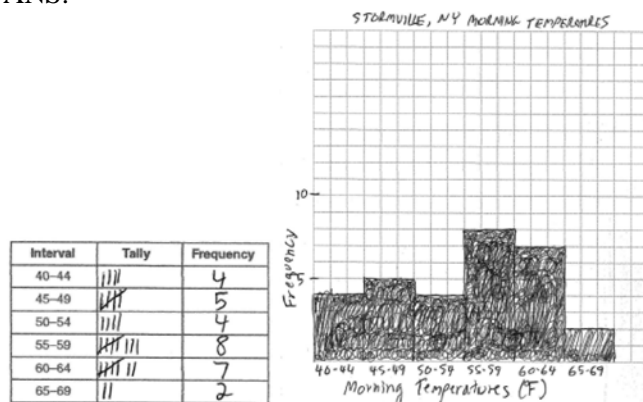

PTS: 4

REF: 060938ia

STA: A.S.5

TOP: Frequency Histograms, Bar Graphs and Tables

KEY: frequency histograms

387 ANS: 2

The median score, 10, is the vertical line in the center of the box.

PTS: 2

REF: fall0709ia

STA: A.S.5

TOP: Box-and-Whisker Plots

388 ANS:

618.45, 613.44, 0.008. $21.7 \times 28.5 = 618.45$. $21.6 \times 28.4 = 613.44$. $\left| \frac{618.45 - 613.44}{613.44} \right| \approx 0.008$. An error of less than 1% would seem to be insignificant.

PTS: 4

REF: 060838ia

STA: A.M.3

TOP: Error

KEY: area

389 ANS: 3

$$x^2 - 10x + 21 = 0$$

$$(x - 7)(x - 3) = 0$$

$$x = 7 \quad x = 3$$

PTS: 2 REF: 010914ia STA: A.A.28 TOP: Roots of Quadratics

390 ANS: 2 PTS: 2 REF: 080916ia STA: A.G.8

TOP: Solving Quadratics by Graphing

391 ANS: 3 PTS: 2 REF: 010910ia STA: A.A.35

TOP: Writing Linear Equations

392 ANS: 2

$$m = \frac{5-3}{2-7} = -\frac{2}{5}$$

PTS: 2 REF: 010913ia STA: A.A.33 TOP: Slope

393 ANS: 2 PTS: 2 REF: 080930ia STA: A.S.17

TOP: Scatter Plots

394 ANS: 4

$$\frac{25x - 125}{x^2 - 25} = \frac{25(x - 5)}{(x + 5)(x - 5)} = \frac{25}{x + 5}$$

PTS: 2 REF: 080821ia STA: A.A.16 TOP: Rational Expressions

KEY: $a > 0$

395 ANS: 2 PTS: 2 REF: 080901ia STA: A.A.4

TOP: Modeling Equations

396 ANS:

$$60. {}_5P_3 = 60$$

PTS: 2 REF: 060931ia STA: A.N.8 TOP: Permutations

397 ANS:

56. If the circumference of circle O is 16π inches, the diameter, \overline{AD} , is 16 inches and the length of \overline{BC} is 12 inches $\frac{3}{4} \times 16$. The area of trapezoid $ABCD$ is $\frac{1}{2} \times 4(12 + 16) = 56$.

PTS: 3 REF: 060934ia STA: A.G.1 TOP: Compositions of Polygons and Circles

KEY: area

398 ANS: 2 PTS: 2 REF: 010909ia STA: A.A.19

TOP: Factoring the Difference of Perfect Squares

399 ANS: 2

$$P = 2l + 2w$$

$$P - 2l = 2w$$

$$\frac{P - 2l}{2} = w$$

PTS: 2 REF: 010911ia STA: A.A.23 TOP: Transforming Formulas

400 ANS: 2

The two values are shoe size and height.

PTS: 2

REF: fall0714ia

STA: A.S.2

TOP: Analysis of Data

401 ANS: 4

$$w(w + 5) = 36$$

$$w^2 + 5w - 36 = 0$$

PTS: 2

REF: fall0726ia

STA: A.A.5

TOP: Modeling Equations

402 ANS: 2

$$\frac{9x^4 - 27x^6}{3x^3} = \frac{9x^4(1 - 3x^2)}{3x^3} = 3x(1 - 3x^2)$$

PTS: 2

REF: fall0718ia

STA: A.A.16

TOP: Rational Expressions

KEY: $a > 0$

403 ANS: 1

PTS: 2

REF: 060807ia

STA: A.A.13

TOP: Multiplication of Polynomials

404 ANS: 2

PTS: 2

REF: 060908ia

STA: A.S.21

TOP: Empirical Probability

405 ANS: 1

PTS: 2

REF: 060801ia

STA: A.G.4

TOP: Families of Functions

406 ANS: 3

$$\sqrt{72} = \sqrt{36} \sqrt{2} = 6\sqrt{2}$$

PTS: 2

REF: 010920ia

STA: A.N.2

TOP: Simplifying Radicals

407 ANS: 4

$$\frac{x^2 - 1}{x + 1} \cdot \frac{x + 3}{3x - 3} = \frac{(x + 1)(x - 1)}{x + 1} \cdot \frac{x + 3}{3(x - 1)} = \frac{x + 3}{3}$$

PTS: 2

REF: 060815ia

STA: A.A.18

TOP: Multiplication and Division of Rationals

KEY: multiplication

408 ANS:

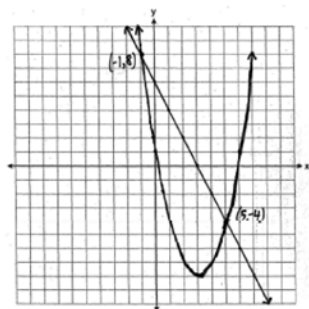

PTS: 4

REF: 060939ia

STA: A.G.9

TOP: Quadratic-Linear Systems

- 409 ANS: 4
The transformation is a reflection in the x -axis.
- PTS: 2 REF: fall0722ia STA: A.G.5 TOP: Graphing Absolute Value Functions
- 410 ANS: 4 PTS: 2 REF: 060927ia STA: A.N.4
TOP: Operations with Scientific Notation
- 411 ANS: 3
 $35000(1 - 0.05)^4 \approx 28507.72$
- PTS: 2 REF: fall0719ia STA: A.A.9 TOP: Exponential Functions
- 412 ANS: 3
 $3^2 + 5^2 = x^2$
 $34 = x^2$
 $\sqrt{34} = x$
- PTS: 2 REF: 060909ia STA: A.A.45 TOP: Pythagorean Theorem
- 413 ANS: 2
 $1.5^3 = 3.375$
- PTS: 2 REF: 060809ia STA: A.G.2 TOP: Volume
- 414 ANS: 1 PTS: 2 REF: 080824ia STA: A.A.43
TOP: Using Trigonometry to Find an Angle
- 415 ANS: 1 PTS: 2 REF: fall0728ia STA: A.A.15
TOP: Undefined Rationals
- 416 ANS: 2
 $l(l - 5) = 24$
 $l^2 - 5l - 24 = 0$
 $(l - 8)(l + 3) = 0$
 $l = 8$
- PTS: 2 REF: 080817ia STA: A.A.8 TOP: Geometric Applications of Quadratics

417 ANS:

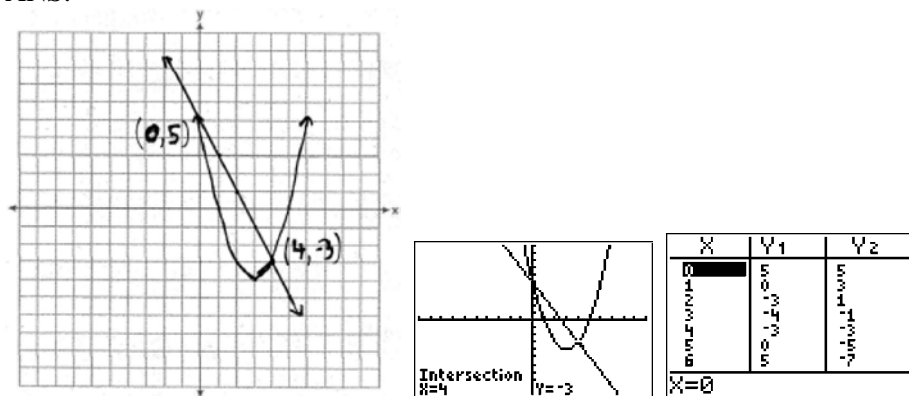

PTS: 4 REF: fall0738ia STA: A.G.9 TOP: Quadratic-Linear Systems

418 ANS: 3 PTS: 2 REF: fall0702ia STA: A.S.23
TOP: Theoretical Probability KEY: mutually exclusive events419 ANS: 3
mean = 6, median = 6 and mode = 7

PTS: 2 REF: 080804ia STA: A.S.4 TOP: Central Tendency

420 ANS: 4
 $A = \{2, 4, 6, 8, 10, 12, 14, 16, 18, 20\}$

PTS: 2 REF: 080912ia STA: A.A.30 TOP: Set Theory

421 ANS:
33.4. Serena needs 24 ($9 + 6 + 9$) feet of fencing to surround the rectangular portion of the garden. The length of the fencing needed for the semicircular portion of the garden is $\frac{1}{2}\pi d = 3\pi \approx 9.4$ feet.PTS: 2 REF: fall0733ia STA: A.G.1 TOP: Compositions of Polygons and Circles
KEY: perimeter422 ANS:
315,000, 180,000, the median better represents value since it is closer to more prices than the mean.PTS: 4 REF: 060839ia STA: A.S.4
TOP: Frequency Histograms, Bar Graphs and Tables423 ANS: 3
 $0.75 \text{ hours} = 45 \text{ minutes. } \frac{120}{1} = \frac{x}{45}$
 $x = 5400$

PTS: 2 REF: 080814ia STA: A.M.1 TOP: Using Rate

424 ANS: 4
 $\frac{2^6}{2^1} = 2^5$

PTS: 2 REF: 060813ia STA: A.A.12 TOP: Division of Powers

425 ANS: 3
 $25 - 18 = 7$

PTS: 2 REF: 060822ia STA: A.S.9
 TOP: Frequency Histograms, Bar Graphs and Tables

426 ANS: 2
 $L + S = 47$
 $L - S = 15$
 $2L = 62$
 $L = 31$

PTS: 2 REF: 060912ia STA: A.A.7 TOP: Writing Linear Systems

427 ANS: 1
 $-2x + 5 > 17$
 $-2x > 12$
 $x < -6$

PTS: 2 REF: fall0724ia STA: A.A.21 TOP: Interpreting Solutions

428 ANS: 2
 The volume of the cube using Ezra's measurements is $8 (2^3)$. The actual volume is $9.261 (2.1^3)$. The relative error is $\left| \frac{9.261 - 8}{9.261} \right| \approx 0.14$.

PTS: 2 REF: 060928ia STA: A.M.3 TOP: Error
 KEY: volume and surface area

429 ANS:
 $m = 50¢, p = 15¢. 3m + 2p = 1.80. 9m + 6p = 5.40 . 4(.50) + 6p = 2.90$
 $4m + 6p = 2.90 \quad 4m + 6p = 2.90 \quad 6p = .90$
 $5m = 2.50 \quad p = \$0.15$
 $m = \$0.50$

PTS: 4 REF: 080837ia STA: A.A.7 TOP: Writing Linear Systems

430 ANS: 1
 ${}_4P_4 = 4 \times 3 \times 2 \times 1 = 24$

PTS: 2 REF: 080816ia STA: A.N.8 TOP: Permutations

431 ANS: 3
 $(3 - 1) \times 2 \times 3 = 12$

PTS: 2 REF: 080905ia STA: A.N.7 TOP: Conditional Probability

432 ANS: 2

$$\frac{x^2 - 2x - 15}{x^2 + 3x} = \frac{(x-5)(x+3)}{x(x+3)} = \frac{x-5}{x}$$

PTS: 2 REF: 060921ia STA: A.A.16 TOP: Rational Expressions

KEY: $a > 0$

433 ANS: 1

$$13.95 + 0.49s \leq 50.00$$

$$0.49s \leq 36.05$$

$$s \leq 73.57$$

PTS: 2 REF: 080904ia STA: A.A.6 TOP: Modeling Inequalities

434 ANS: 4

$$A = lw = (3w - 7)(w) = 3w^2 - 7w$$

PTS: 2 REF: 010924ia STA: A.A.1 TOP: Expressions

435 ANS: 3 PTS: 2 REF: 060817ia STA: A.A.15

TOP: Undefined Rationals

436 ANS:

$$w(w + 15) = 54, 3, 18. \quad w(w + 15) = 54$$

$$w^2 + 15w - 54 = 0$$

$$(w + 18)(w - 3) = 0$$

$$w = 3$$

PTS: 4 REF: 060837ia STA: A.A.8 TOP: Geometric Applications of Quadratics

437 ANS:

$$\frac{3}{8}. \text{ (H,H,H), (H,H,T), (H,T,H), (H,T,T), (T,H,H), (T,H,T), (T,T,H), (T,T,T)}$$

PTS: 2 REF: 080933ia STA: A.S.19 TOP: Sample Space

438 ANS:

$$\{1,2,4,5,9,10,12\}$$

PTS: 2 REF: 080833ia STA: A.A.30 TOP: Set Theory

439 ANS: 4

$$-4x + 2 > 10$$

$$-4x > 8$$

$$x < -2$$

PTS: 2 REF: 080805ia STA: A.A.21 TOP: Interpreting Solutions

440 ANS:

$\frac{1}{8}$. After the English and social studies books are taken, 8 books are left and 1 is an English book.

PTS: 2 REF: 060933ia STA: A.S.18 TOP: Conditional Probability

441 ANS: 4 PTS: 2 REF: fall0715ia STA: A.A.5

TOP: Modeling Inequalities

442 ANS: 3

$$F = \frac{9}{5}C + 32 = \frac{9}{5}(15) + 32 = 59$$

PTS: 2 REF: 010901ia STA: A.M.2 TOP: Conversions

KEY: formula

443 ANS: 4

Let x = youngest brother and $x + 4$ = oldest brother. $3x - (x + 4) = 48$.

$$2x - 4 = 48$$

$$x = 26$$

PTS: 2 REF: 080928ia STA: A.A.6 TOP: Modeling Equations

444 ANS: 1

$$x - 2y = 1$$

$$x + 4y = 7$$

$$-6y = -6$$

$$y = 1$$

PTS: 2 REF: 080920ia STA: A.A.10 TOP: Solving Linear Systems

445 ANS: 3 PTS: 2 REF: 060924ia STA: A.G.8

TOP: Solving Quadratics by Graphing

446 ANS: 4 PTS: 2 REF: 080903ia STA: A.A.12

TOP: Multiplication of Powers

447 ANS: 1

$$x^2 + 7x + 10 = 0$$

$$(x + 5)(x + 2) = 0$$

$$x = -5 \text{ or } -2$$

PTS: 2 REF: 080918ia STA: A.A.15 TOP: Undefined Rationals

448 ANS: 3 PTS: 2 REF: 080819ia STA: A.A.13

TOP: Addition and Subtraction of Polynomials

KEY: subtraction

449 ANS: 4 PTS: 2 REF: 060916ia STA: A.A.15

TOP: Undefined Rationals

450 ANS: 1

A rooster crows before sunrise, not because of the sun.

PTS: 2 REF: fall0707ia STA: A.S.14 TOP: Analysis of Data

451 ANS: 1 PTS: 2 REF: 080924ia STA: A.G.1
TOP: Compositions of Polygons and Circles KEY: perimeter

452 ANS:
(H,F,M), (H,F,J), (H,F,S), (H,A,M), (H,A,J), (H,A,S), (C,F,M), (C,F,J), (C,F,S), (C,A,M), (C,A,J), (C,A,S),
(T,F,M), (T,F,J), (T,F,S), (T,A,M), (T,A,J), (T,A,S). There are 18 different kids' meals, 12 do not include juice
and 6 include chicken nuggets.

PTS: 4 REF: 010939ia STA: A.S.19 TOP: Sample Space
453 ANS: 3 PTS: 2 REF: 060808ia STA: A.N.8
TOP: Permutations

454 ANS: 1
$$\frac{\sqrt{32}}{4} = \frac{\sqrt{16} \sqrt{2}}{4} = \sqrt{2}$$

PTS: 2 REF: 060828ia STA: A.N.2 TOP: Simplifying Radicals
455 ANS: 2

$$\tan 32 = \frac{x}{25}$$

$$x \approx 15.6$$

PTS: 2 REF: 080914ia STA: A.A.44 TOP: Using Trigonometry to Find a Side
456 ANS:

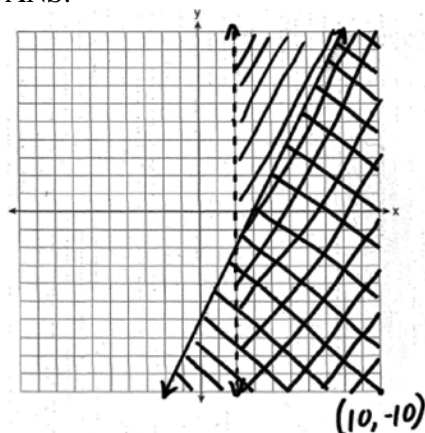

PTS: 4 REF: 010938ia STA: A.G.7 TOP: Systems of Linear Inequalities
457 ANS: 1

$$x = \frac{-b}{2a} = \frac{-(-16)}{2(1)} = 8. \quad y = (8)^2 - 16(8) + 63 = -1$$

PTS: 2 REF: 060918ia STA: A.A.41 TOP: Identifying the Vertex of a Quadratic Given Equation

458 ANS: 1
The slope of both is -4 .

PTS: 2 REF: 060814ia STA: A.A.38 TOP: Parallel and Perpendicular Lines

459 ANS: 1 PTS: 2 REF: 080813ia STA: A.G.10
TOP: Identifying the Vertex of a Quadratic Given Graph

460 ANS: 4

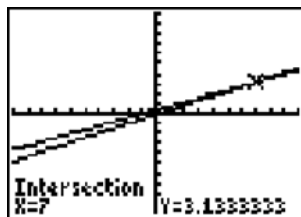

$$\frac{2x}{5} + \frac{1}{3} = \frac{7x-2}{15}$$

$$\frac{(2x \times 3) + (5 \times 1)}{5 \times 3} = \frac{7x-2}{15}$$

$$\frac{6x+5}{15} = \frac{7x-2}{15}$$

$$6x+5 = 7x-2$$

$$x = 7$$

PTS: 2 REF: 080820ia STA: A.A.25
TOP: Solving Equations with Fractional Expressions

461 ANS:

$$5,583.86. A = P(1 + R)^t = 5000(1 + 0.0375)^3 \approx 5583.86$$

PTS: 3 REF: 060935ia STA: A.A.9 TOP: Exponential Functions
462 ANS: 2 PTS: 2 REF: 011411ia STA: A.S.17
TOP: Scatter Plots

463 ANS: 4 PTS: 2 REF: 080827ia STA: A.A.12
TOP: Powers of Powers

464 ANS: 2

If the car can travel 75 miles on 4 gallons, it can travel 300 miles on 16 gallons. $\frac{75}{4} = \frac{x}{16}$.

$$x = 300$$

PTS: 2 REF: 080807ia STA: A.G.4 TOP: Graphing Linear Functions
465 ANS: 2

$$x + 2y = 9$$

$$x - y = 3$$

$$3y = 6$$

$$y = 2$$

PTS: 2 REF: 060925ia STA: A.A.10 TOP: Solving Linear Systems

466 ANS: 4

$$-2(x - 5) < 4$$

$$-2x + 10 < 4$$

$$-2x < -6$$

$$x > 3$$

PTS: 2 REF: 080913ia STA: A.A.21 TOP: Interpreting Solutions

467 ANS: 2

$$5\sqrt{20} = 5\sqrt{4}\sqrt{5} = 10\sqrt{5}$$

PTS: 2 REF: 080922ia STA: A.N.2 TOP: Simplifying Radicals

468 ANS: 1

$$\frac{4x}{x-1} \cdot \frac{x^2-1}{3x+3} = \frac{4x}{x-1} \cdot \frac{(x+1)(x-1)}{3(x+1)} = \frac{4x}{3}$$

PTS: 2 REF: 080826ia STA: A.A.18 TOP: Multiplication and Division of Rationals

KEY: multiplication

469 ANS: 2

$$\sqrt{32} = \sqrt{16}\sqrt{2} = 4\sqrt{2}$$

PTS: 2 REF: 060910ia STA: A.N.2 TOP: Simplifying Radicals

470 ANS: 1

$$\sin C = \frac{\text{opposite}}{\text{hypotenuse}} = \frac{13}{85}$$

PTS: 2 REF: fall0721ia STA: A.A.42 TOP: Trigonometric Ratios

471 ANS:

$$\text{Ann's. } \frac{225}{15} = 15 \text{ mpg is greater than } \frac{290}{23.2} = 12.5 \text{ mpg}$$

PTS: 2 REF: 060831ia STA: A.M.1 TOP: Using Rate

472 ANS: 3

An element of the domain, 1, is paired with two different elements of the range, 3 and 7.

PTS: 2 REF: 080919ia STA: A.G.3 TOP: Defining Functions

KEY: ordered pairs

473 ANS:

$$\frac{3}{x+5} = \frac{2x}{x^2-8}$$

$$3x^2 - 24 = 2x^2 + 10x$$

$$x^2 - 10x + 24 = 0$$

$$(x-12)(x+2) = 0$$

$$x = 12, -2$$

PTS: 4 REF: 011438ia STA: A.A.26 TOP: Solving Rationals

474 ANS: 4 PTS: 2 REF: 010930ia STA: A.G.3

TOP: Defining Functions KEY: graphs

475 ANS: 1

$$0.07m + 19 \leq 29.50$$

$$0.07m \leq 10.50$$

$$m \leq 150$$

PTS: 2 REF: 010904ia STA: A.A.6 TOP: Modeling Inequalities

476 ANS: 1 PTS: 2 REF: 060811ia STA: A.G.10

TOP: Identifying the Vertex of a Quadratic Given Graph

477 ANS:

$$1,512, 1,551.25, 0.025. \quad 36 \times 42 = 1512. \quad 36.5 \times 42.5 = 1551.25. \quad RE = \left| \frac{1512 - 1551.25}{1551.25} \right| \approx 0.025.$$

PTS: 3 REF: 010934ia STA: A.M.3 TOP: Error

KEY: area

478 ANS: 2

$$s + o = 126. \quad s + 2s = 126$$

$$o = 2s \quad s = 42$$

PTS: 2 REF: 080811ia STA: A.A.7 TOP: Writing Linear Systems

479 ANS: 2

$$\sin A = \frac{8}{12}$$

$$A \approx 42$$

PTS: 2 REF: 060816ia STA: A.A.43 TOP: Using Trigonometry to Find an Angle

480 ANS: 1 PTS: 2 REF: 060903ia STA: A.A.12

TOP: Division of Powers

481 ANS: 2

$$\sin U = \frac{\text{opposite}}{\text{hypotenuse}} = \frac{15}{17}$$

PTS: 2 REF: 010919ia STA: A.A.42 TOP: Trigonometric Ratios

482 ANS: 1

Everyone eats, can shop in malls and wear clothes. People who work in a sporting goods store probably watch more sports television than most.

PTS: 2 REF: 010923ia STA: A.S.3 TOP: Analysis of Data

483 ANS: 4

$$V = \pi r^2 h = \pi \cdot 6^2 \cdot 15 \approx 1696.5$$

PTS: 2 REF: fall0712ia STA: A.G.2 TOP: Volume

484 ANS: 2

$$\left| \frac{149.6 - 174.2}{149.6} \right| \approx 0.1644$$

PTS: 2 REF: 080926ia STA: A.M.3 TOP: Error

KEY: area

485 ANS: 2 PTS: 2 REF: 010925ia STA: A.A.15

TOP: Undefined Rationals

486 ANS: 2 PTS: 2 REF: 060830ia STA: A.A.9

TOP: Exponential Functions

487 ANS:

$$\frac{x-7}{3x} \cdot \frac{2x^2-8x-42}{6x^2} \div \frac{x^2-9}{x^2-3x} = \frac{2(x^2-4x-21)}{6x^2} \cdot \frac{x(x-3)}{(x+3)(x-3)} = \frac{(x-7)(x+3)}{3x} \cdot \frac{1}{x+3} = \frac{x-7}{3x}$$

PTS: 4 REF: 080937ia STA: A.A.18 TOP: Multiplication and Division of Rationals

KEY: division

488 ANS: 2 PTS: 2 REF: 080815ia STA: A.G.1

TOP: Compositions of Polygons and Circles

KEY: area

489 ANS: 2 PTS: 2 REF: fall0725ia STA: A.N.4

TOP: Operations with Scientific Notation

490 ANS:

$$\frac{3}{4x-8} \cdot \frac{3x+6}{4x+12} \div \frac{x^2-4}{x+3} = \frac{3(x+2)}{4(x+3)} \cdot \frac{x+3}{(x+2)(x-2)} = \frac{3}{4(x-2)}$$

PTS: 3 REF: 010935ia STA: A.A.18 TOP: Multiplication and Division of Rationals

KEY: division

491 ANS:

Number of Days Outside			Number of Days Outside	
Interval	Tally	Frequency	Interval	Cumulative Frequency
0-1		3	0-1	3
2-3		7	0-3	10
4-5		7	0-5	17
6-7		3	0-7	20

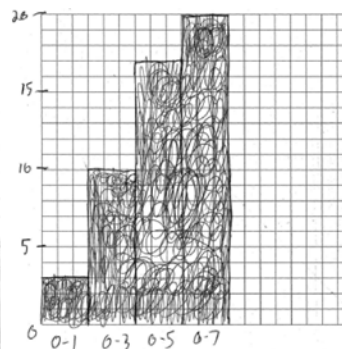

PTS: 4 REF: 080838ia STA: A.S.5
 TOP: Frequency Histograms, Bar Graphs and Tables

KEY: cumulative frequency histograms

492 ANS:

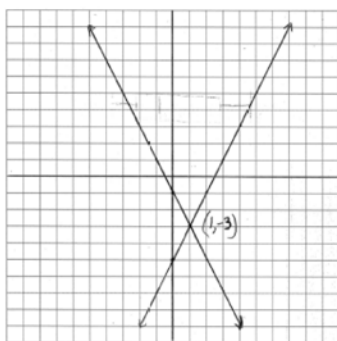

PTS: 4 REF: 080938ia STA: A.G.7 TOP: Solving Linear Systems

493 ANS:

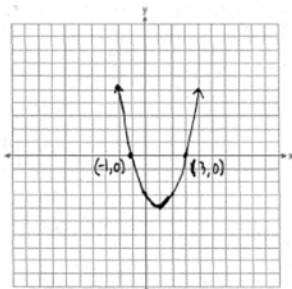

PTS: 3 REF: 060836ia STA: A.G.8 TOP: Solving Quadratics by Graphing

494 ANS:

225000, 175000, the median better represents the value since it is closer to more values than the mean.

PTS: 4 REF: fall0737ia STA: A.S.4
 TOP: Frequency Histograms, Bar Graphs and Tables

495 ANS: 2

$$2x^2 + 10x - 12 = 2(x^2 + 5x - 6) = 2(x + 6)(x - 1)$$

PTS: 2 REF: 080806ia STA: A.A.20 TOP: Factoring Polynomials

496 ANS:

$$30\sqrt{2}. \quad 5\sqrt{72} = 5\sqrt{36}\sqrt{2} = 30\sqrt{2}$$

PTS: 2 REF: fall0731ia STA: A.N.2 TOP: Simplifying Radicals

497 ANS:

Not all of the homework problems are equations. The first problem is an expression.

PTS: 2 REF: 080931ia STA: A.A.3 TOP: Expressions

498 ANS:

$$(-2, 11). \quad x = \frac{-b}{2a} = \frac{-(-8)}{2(-2)} = -2$$

$$y = -2(-2)^2 - 8(-2) + 3 = 11$$

PTS: 3 REF: 080934ia STA: A.A.41
TOP: Identifying the Vertex of a Quadratic Given Equation

499 ANS: 3

$$\sin A = \frac{10}{16} \quad B = 180 - (90 + 38.7) = 51.3. \quad \text{A } 90^\circ \text{ angle is not acute.}$$

$$A \approx 38.7$$

PTS: 2 REF: 080829ia STA: A.A.43 TOP: Using Trigonometry to Find an Angle

500 ANS:

$$39, 63. \quad \tan 52 = \frac{50}{x}. \quad \sin 52 = \frac{50}{x}$$

$$x \approx 39 \quad x \approx 63$$

PTS: 4 REF: 060937ia STA: A.A.44 TOP: Using Trigonometry to Find a Side

501 ANS:

$$50. \quad 12 + 10 + 12 + \frac{1}{2}(10\pi) \approx 50$$

PTS: 2 REF: 010931ia STA: A.G.1 TOP: Compositions of Polygons and Circles
KEY: perimeter

502 ANS: 3 PTS: 2 REF: 010917ia STA: A.A.29

TOP: Set Theory

503 ANS:

$$111.25. \quad \frac{\text{distance}}{\text{time}} = \frac{89}{0.8} = 111.25$$

PTS: 2 REF: 080831ia STA: A.M.1 TOP: Speed

504 ANS: 1

$$\left| \frac{289 - 282}{289} \right| \approx 0.024$$

PTS: 2 REF: 080828ia STA: A.M.3 TOP: Error

KEY: volume and surface area

505 ANS: 2 PTS: 2 REF: 010916ia STA: A.G.10
 TOP: Identifying the Vertex of a Quadratic Given Graph

506 ANS: 1
 $\frac{4}{3}x + 5 < 17$
 $\frac{4}{3}x < 12$
 $4x < 36$
 $x < 9$

PTS: 2 REF: 060914ia STA: A.A.21 TOP: Interpreting Solutions
 507 ANS: 1
 $so = f + 60 \quad j = 2f - 50 \quad se = 3f. \quad f + (f + 60) + (2f - 50) + 3f = 1424$

$$7f + 10 = 1424$$

$$f = 202$$

PTS: 2 REF: 060917ia STA: A.A.7 TOP: Writing Linear Systems
 508 ANS: 4

$$A(-3, 4) \text{ and } B(5, 8). \quad m = \frac{4 - 8}{-3 - 5} = \frac{-4}{-8} = \frac{1}{2}$$

PTS: 2 REF: 011007ia STA: A.A.33 TOP: Slope

Integrated Algebra Regents at Random Answer Section

509 ANS: 2 PTS: 2 REF: 081127ia STA: A.A.40
TOP: Systems of Linear Inequalities

510 ANS: 2
$$m = \frac{5-2}{3-(-2)} = \frac{3}{5}$$

PTS: 2 REF: 061004ia STA: A.A.33 TOP: Slope
511 ANS:

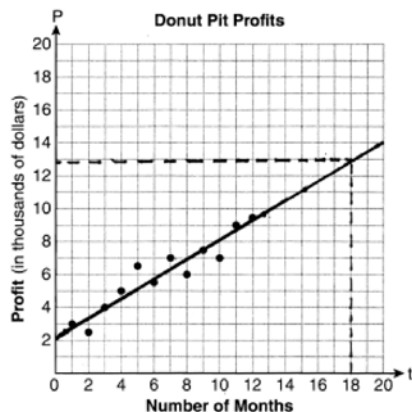

They will not reach their goal in 18 months.

PTS: 3 REF: 061036ia STA: A.S.17 TOP: Scatter Plots
512 ANS:

$$84, 71 \quad \sin 50 = \frac{x}{110} \quad \cos 50 = \frac{y}{110}$$

$$x \approx 84 \quad y \approx 71$$

PTS: 4 REF: 081039ia STA: A.A.44 TOP: Using Trigonometry to Find a Side
513 ANS: 1 PTS: 2 REF: 081115ia STA: A.A.32
TOP: Slope

514 ANS:
30, 20, 71-80, 81-90 and 91-100

PTS: 4 REF: 061038ia STA: A.S.9
TOP: Frequency Histograms, Bar Graphs and Tables

515 ANS:
80, 136 $V = lwh = 10 \cdot 2 \cdot 4 = 80$ $SA = 2lw + 2hw + 2lh = 2 \cdot 10 \cdot 2 + 2 \cdot 4 \cdot 2 + 2 \cdot 10 \cdot 4 = 136$

PTS: 3 REF: 081035ia STA: A.G.2 TOP: Surface Area
516 ANS: 3 PTS: 2 REF: 081118ia STA: A.G.4
TOP: Families of Functions

517 ANS: 2

$$\sqrt{5^2 + 7^2} \approx 8.6$$

PTS: 2 REF: 081004ia STA: A.A.45 TOP: Pythagorean Theorem

518 ANS: 4

$$\frac{x}{x+4} \div \frac{2x}{x^2-16} = \frac{x}{x+4} \cdot \frac{x^2-16}{2x} = \frac{1}{x+4} \cdot \frac{(x+4)(x-4)}{2} = \frac{x-4}{2}$$

PTS: 2 REF: 081130ia STA: A.A.18 TOP: Multiplication and Division of Rationals
KEY: division

519 ANS: 1

$$-3(-4)^2(2) + 4(-4) = -96 - 16 = -112$$

PTS: 2 REF: 081113ia STA: A.N.6 TOP: Evaluating Expressions

520 ANS: 4

$$x^2 - 4x - 12 = 0$$

$$(x-6)(x+2) = 0$$

$$x = 6 \quad x = -2$$

PTS: 2 REF: 061125ia STA: A.A.15 TOP: Undefined Rationals

521 ANS: 2 PTS: 2 REF: 011015ia STA: A.G.10

TOP: Identifying the Vertex of a Quadratic Given Graph

522 ANS: 1 PTS: 2 REF: 081110ia STA: A.A.1

TOP: Expressions

523 ANS: 2

In (2), each element in the domain corresponds to a unique element in the range.

PTS: 2 REF: 061116ia STA: A.G.3 TOP: Defining Functions
KEY: ordered pairs

524 ANS: 2

$$A(-3, 8) \text{ and } B(3, 6). \quad m = \frac{8-6}{-3-3} = \frac{2}{-6} = -\frac{1}{3}$$

PTS: 2 REF: 081005ia STA: A.A.33 TOP: Slope

525 ANS: 3

$$10^2 + 10^2 = c^2$$

$$c^2 = 200$$

$$c \approx 14.1$$

PTS: 2 REF: 061102ia STA: A.A.45 TOP: Pythagorean Theorem

526 ANS: 4

$$\frac{ey}{n} + k = t$$

$$\frac{ey}{n} = t - k$$

$$y = \frac{n(t-k)}{e}$$

PTS: 2 REF: 011125ia STA: A.A.23 TOP: Transforming Formulas

527 ANS: 2

$$l(l-3) = 40$$

$$l^2 - 3l - 40 = 0$$

$$(l-8)(l+5) = 0$$

$$l = 8$$

PTS: 2 REF: 081116ia STA: A.A.8 TOP: Geometric Applications of Quadratics

528 ANS: 3

$$\frac{(12.3 \times 11.9) - (12.2 \times 11.8)}{12.3 \times 11.9} \approx 0.0165$$

PTS: 2 REF: 061120ia STA: A.M.3 TOP: Error

KEY: area

529 ANS: 2

Candidate *B* received 45%. $45\% \times 1860 = 837$

PTS: 2 REF: 081007ia STA: A.N.5 TOP: Percents

530 ANS: 4

$$2x - 3y = 9$$

$$2(0) - 3(-3) = 9$$

$$0 + 9 = 9$$

PTS: 2 REF: 081016ia STA: A.A.39 TOP: Identifying Points on a Line

531 ANS:

$$2.1. \cos 65 = \frac{x}{5}$$

$$x \approx 2.1$$

PTS: 2 REF: 011133ia STA: A.A.44 TOP: Using Trigonometry to Find a Side

532 ANS: 4

PTS: 2

REF: 061022ia

STA: A.S.3

TOP: Analysis of Data

533 ANS: 3

$$m = \frac{6-4}{3-(-2)} = \frac{2}{5}$$

PTS: 2

REF: 061110ia

STA: A.A.33

TOP: Slope

534 ANS: 1

PTS: 2

REF: 061010ia

STA: A.A.40

TOP: Systems of Linear Inequalities

535 ANS: 1

$$b = 2j + 4 \quad 2j + 4 = 31 - j$$

$$b + j = 31 \quad 3j = 27$$

$$b = 31 - j \quad j = 9$$

PTS: 2

REF: 081119ia

STA: A.A.7

TOP: Writing Linear Systems

536 ANS:

$$\frac{x^2 + 9x + 14}{x^2 - 49} \div \frac{3x + 6}{x^2 + x - 56} = \frac{(x+7)(x+2)}{(x+7)(x-7)} \cdot \frac{(x+8)(x-7)}{3(x+2)} = \frac{x+8}{3}$$

PTS: 4

REF: 061037ia

STA: A.A.18

TOP: Multiplication and Division of Rationals

KEY: division

537 ANS: 2

PTS: 2

REF: 011027ia

STA: A.A.3

TOP: Expressions

538 ANS: 1

PTS: 2

REF: 081030ia

STA: A.A.3

TOP: Expressions

539 ANS: 2

PTS: 2

REF: 011002ia

STA: A.S.20

TOP: Theoretical Probability

540 ANS: 2

PTS: 2

REF: 011110ia

STA: A.N.6

TOP: Evaluating Expressions

541 ANS:

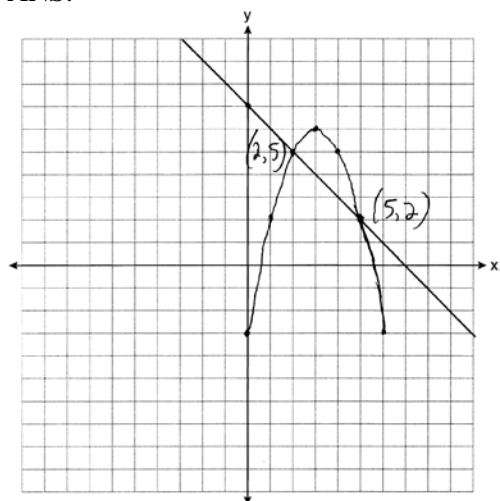

PTS: 4

REF: 081138ia

STA: A.G.9

TOP: Quadratic-Linear Systems

542 ANS: 1

$$-|a - b| = -|7 - (-3)| = -|-10| = -10$$

PTS: 2 REF: 011010ia STA: A.N.6 TOP: Evaluating Expressions

543 ANS:

$$\frac{600 - 592}{592} \approx 0.014$$

PTS: 2 REF: 061031ia STA: A.M.3 TOP: Error

KEY: volume and surface area

544 ANS: 3

$$\frac{15}{15 + 13 + 12} = \frac{15}{40} = \frac{3}{8}$$

PTS: 2 REF: 061006ia STA: A.S.21 TOP: Experimental Probability

545 ANS: 4

The other sets of data are qualitative.

PTS: 2 REF: 011116ia STA: A.S.1 TOP: Analysis of Data

546 ANS: 4

$$\frac{2 + 3 + 0 + 1 + 3 + 2 + 4 + 0 + 2 + 3}{10} = \frac{20}{10} = 2 \quad \frac{x}{10} = 2 + 0.5$$

$$x = 25$$

PTS: 2 REF: 081020ia STA: A.S.16 TOP: Average Known with Missing Data

547 ANS:

$$\frac{1375}{1600} \cdot \frac{40^2 - 15^2}{40^2} = \frac{1375}{1600}$$

PTS: 2 REF: 011132ia STA: A.S.20 TOP: Geometric Probability

548 ANS:

$$\frac{x^2 - 5x - 24}{x - 8} = \frac{(x - 8)(x + 3)}{x - 8} = x + 3$$

PTS: 2 REF: 061131ia STA: A.A.16 TOP: Rational Expressions

KEY: $a > 0$

549 ANS: 3 PTS: 2 REF: 011017ia STA: A.G.5

TOP: Graphing Absolute Value Functions

550 ANS: 1

$$f + m = 53$$

$$f - m = 25$$

$$2m = 28$$

$$m = 14$$

PTS: 2 REF: 061126ia STA: A.A.7 TOP: Writing Linear Systems

551 ANS: 2

$$36x^2 - 100y^6 = 4(9x^2 - 25y^6) = 4(3x + 5y^3)(3x - 5y^3)$$

PTS: 2 REF: 081129ia STA: A.A.19

TOP: Factoring the Difference of Perfect Squares

552 ANS: 1 PTS: 2 REF: 011101ia STA: A.A.31

TOP: Set Theory

553 ANS: 2 PTS: 2 REF: 061128ia STA: A.A.29

TOP: Set Theory

554 ANS: 3 PTS: 2 REF: 011117ia STA: A.G.4

TOP: Graphing Absolute Value Functions

555 ANS:

$$53. \sin A = \frac{16}{20}$$

$$A \approx 53$$

PTS: 2 REF: 011032ia STA: A.A.43 TOP: Using Trigonometry to Find an Angle

556 ANS: 2 PTS: 2 REF: 081003ia STA: A.A.31

TOP: Set Theory

557 ANS: 4

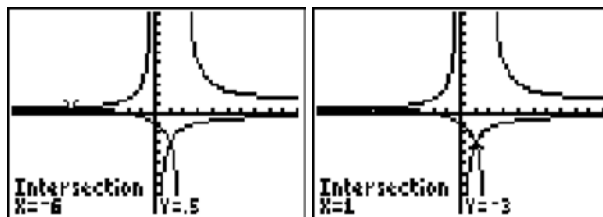

$$\frac{x+2}{x-2} = \frac{-3}{x}$$

$$x(x+2) = -3(x-2)$$

$$x^2 + 2x = -3x + 6$$

$$x^2 + 5x - 6 = 0$$

$$(x+6)(x-1) = 0$$

$$x = -6 \text{ or } 1$$

PTS: 2 REF: 011028ia STA: A.A.26 TOP: Solving Rationals

558 ANS: 2

$$a^3 - 4a = a(a^2 - 4) = a(a-2)(a+2)$$

PTS: 2 REF: 011108ia STA: A.A.19

TOP: Factoring the Difference of Perfect Squares

559 ANS: 4 PTS: 2 REF: 011114ia STA: A.N.1

TOP: Properties of Reals

560 ANS: 2

$$\left| \frac{13.5 - 12.8}{13.5} \right| \approx 0.093$$

PTS: 2 REF: 081123ia STA: A.M.3 TOP: Error
KEY: area

561 ANS: 1 PTS: 2 REF: 011004ia STA: A.A.31

TOP: Set Theory

562 ANS: 2 PTS: 2 REF: 061027ia STA: A.A.20

TOP: Factoring Polynomials

563 ANS: 2

$$A = lw + \frac{\pi r^2}{2} = 6 \cdot 5 + \frac{\pi \cdot 3^2}{2} \approx 44.1$$

PTS: 2 REF: 061029ia STA: A.G.1 TOP: Compositions of Polygons and Circles
KEY: area

564 ANS: 1

$$\frac{x^2 - x - 6}{x^2 - 5x + 6} = \frac{(x-3)(x+2)}{(x-3)(x+2)} = \frac{x+2}{x-2}$$

PTS: 2 REF: 011130ia STA: A.A.16 TOP: Rational Expressions
KEY: $a > 0$

565 ANS: 3

$$\begin{aligned} 2x - 5y &= 11 & 2x - 5(-1) &= 11 \\ -2x + 3y &= -9 & 2x &= 6 \\ -2y &= 2 & x &= 3 \\ y &= -1 \end{aligned}$$

PTS: 2 REF: 081109ia STA: A.A.10 TOP: Solving Linear Systems

566 ANS: 4 PTS: 2 REF: 081107ia STA: A.A.5

TOP: Modeling Inequalities

567 ANS: 2

$$\frac{3}{2x} + \frac{7}{4x} = \frac{12x + 14x}{8x^2} = \frac{26x}{8x^2} = \frac{13}{4x}$$

PTS: 2 REF: 011120ia STA: A.A.17 TOP: Addition and Subtraction of Rationals

568 ANS: 2

$$\tan B = \frac{\text{opposite}}{\text{adjacent}} = \frac{8}{15} = 0.5\bar{3}$$

PTS: 2 REF: 081026ia STA: A.A.42 TOP: Trigonometric Ratios

569 ANS:
 $x = 1; (1, -5)$

PTS: 2 REF: 061133ia STA: A.G.10
 TOP: Identifying the Vertex of a Quadratic Given Graph

570 ANS: 2 PTS: 2 REF: 011023ia STA: A.A.40
 TOP: Systems of Linear Inequalities

571 ANS: 2

$$\cos 38 = \frac{10}{x}$$

$$x = \frac{10}{\cos 38} \approx 12.69$$

PTS: 2 REF: 081126ia STA: A.A.44 TOP: Using Trigonometry to Find a Side

572 ANS:

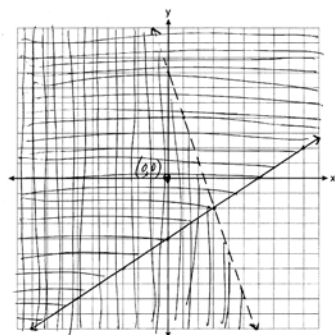

PTS: 4 REF: 061139ia STA: A.G.7 TOP: Systems of Linear Inequalities

573 ANS: 1

Asking school district employees about a school board candidate produces the most bias.

PTS: 2 REF: 061107ia STA: A.S.3 TOP: Analysis of Data

574 ANS: 1 PTS: 2 REF: 061114ia STA: A.A.43

TOP: Using Trigonometry to Find an Angle

575 ANS: 2

shaded = whole – unshaded

= rectangle-triangle

$$= lw - \frac{1}{2}bh$$

$$= 15 \times 6 - \frac{1}{2} \times 15 \times 4.6$$

$$= 90 - 34.5$$

$$= 55.5$$

PTS: 2 REF: 081019ia STA: A.G.1 TOP: Compositions of Polygons and Circles

KEY: area

576 ANS:
81.3, 80, both increase

PTS: 3 REF: 011035ia STA: A.S.16 TOP: Central Tendency

577 ANS: 2
 $x^2 - 2x - 15 = 0$
 $(x - 5)(x + 3) = 0$
 $x = 5$ $x = -3$

PTS: 2 REF: 011128ia STA: A.A.28 TOP: Roots of Quadratics
578 ANS: 2 PTS: 2 REF: 081104ia STA: A.S.13
TOP: Analysis of Data

579 ANS: 3 PTS: 2 REF: 061119ia STA: A.A.2
TOP: Expressions

580 ANS:
Hat A, add 1 not green to Hat A, add 11 green to Hat B, and add none to Hat C.

PTS: 4 REF: 081038ia STA: A.S.22 TOP: Theoretical Probability

581 ANS: 4
 $-3x(x - 4) - 2x(x + 3) = -3x^2 + 12x - 2x^2 - 6x = -5x^2 + 6x$

PTS: 2 REF: 081114ia STA: A.A.13 TOP: Addition and Subtraction of Monomials
582 ANS: 3

$$P(O) = \frac{5}{10}, P(P) = \frac{4}{10}, P(\leq 5) = \frac{6}{10}, P(/3) = \frac{4}{10}$$

PTS: 2 REF: 081125ia STA: A.S.22 TOP: Theoretical Probability
583 ANS: 2

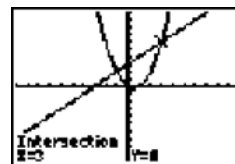

$x^2 - x = x + 3$. Since $y = x + 3$, the solutions are (3, 6) and (-1, 2).

$$x^2 - 2x - 3 = 0$$

$$(x - 3)(x + 1) = 0$$

$$x = 3 \text{ or } -1$$

PTS: 2 REF: 061118ia STA: A.A.11 TOP: Quadratic-Linear Systems

584 ANS:

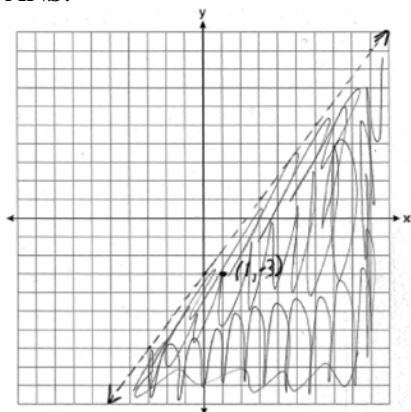

$(1, -3)$ is in the solution set. $4(1) - 3(-3) > 9$

$$4 + 9 > 9$$

PTS: 4 REF: 011038ia STA: A.G.6 TOP: Linear Inequalities

585 ANS: 3

$$\frac{3+2+4+3}{20} = \frac{12}{20}$$

PTS: 2 REF: 011129ia STA: A.S.21 TOP: Experimental Probability

586 ANS: 3

$$c + 3d = 8 \quad c = 4d - 6$$

$$4d - 6 + 3d = 8 \quad c = 4(2) - 6$$

$$7d = 14 \quad c = 2$$

$$d = 2$$

PTS: 2 REF: 061012ia STA: A.A.10 TOP: Solving Linear Systems

587 ANS:

$$2,160 \frac{1,200}{25} = \frac{x}{45}$$

$$25x = 54,000$$

$$x = 2,160$$

PTS: 2 REF: 081032ia STA: A.M.1 TOP: Using Rate

588 ANS: 2 PTS: 2 REF: 061105ia STA: A.A.20

TOP: Factoring Polynomials

589 ANS: 4 PTS: 2 REF: 061123ia STA: A.A.31

TOP: Set Theory

590 ANS: 3

$$\frac{12x^3 - 6x^2 + 2x}{2x} = \frac{2x(6x^2 - 3x + 1)}{2x} = 6x^2 - 3x + 1$$

PTS: 2 REF: 011011ia STA: A.A.14 TOP: Division of Polynomials

591 ANS: 3

$$3\sqrt{2} + \sqrt{8} = 3\sqrt{2} + \sqrt{4}\sqrt{2} = 3\sqrt{2} + 2\sqrt{2} = 5\sqrt{2}$$

PTS: 2

REF: 011121ia

STA: A.N.3

TOP: Operations with Radicals

KEY: addition

592 ANS:

Interval	Tally	Frequency
51-60		2
61-70		2
71-80		4
81-90		6
91-100		4

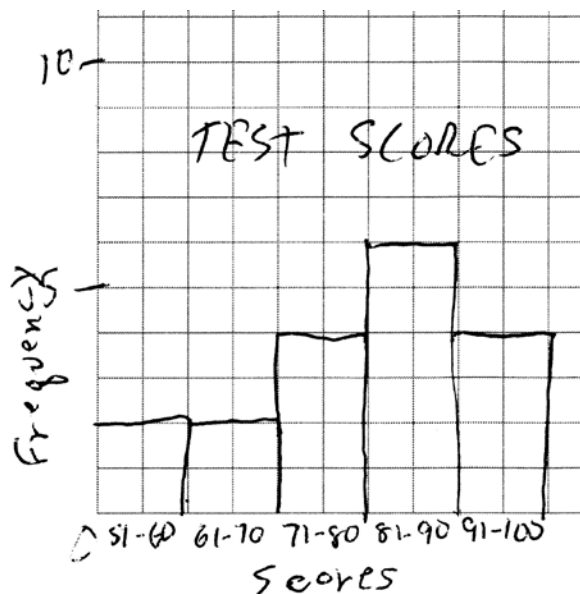

PTS: 3

REF: 011135ia

STA: A.S.5

TOP: Frequency Histograms, Bar Graphs and Tables

KEY: frequency histograms

593 ANS: 2

PTS: 2

REF: 011005ia

STA: A.A.5

TOP: Modeling Inequalities

594 ANS:

$$-2, 3. \quad x^2 - x = 6$$

$$x^2 - x - 6 = 0$$

$$(x - 3)(x + 2) = 0$$

$$x = 3 \text{ or } -2$$

PTS: 3

REF: 011034ia

STA: A.A.28

TOP: Roots of Quadratics

595 ANS: 2

PTS: 2

REF: 081111ia

STA: A.G.10

TOP: Identifying the Vertex of a Quadratic Given Graph

596 ANS:

minimum is 120, 1st quartile is 145, median is 292, 3rd quartile is 407, and maximum is 452

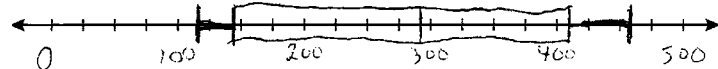

PTS: 3

REF: 081034ia

STA: A.S.5

TOP: Box-and-Whisker Plots

- 597 ANS: 2
Debbie failed to distribute the 3 properly.
- PTS: 2 REF: 011009ia STA: A.A.22 TOP: Solving Equations
- 598 ANS: 2 PTS: 2 REF: 011119ia STA: A.A.29
TOP: Set Theory
- 599 ANS: 1 PTS: 2 REF: 061021ia STA: A.A.29
TOP: Set Theory
- 600 ANS: 2
 $J - M = 3$
 $8J + 8M = 120$
 $8J - 8M = 24$
 $16J = 144$
 $J = 9$
- PTS: 2 REF: 011115ia STA: A.A.7 TOP: Writing Linear Systems
- 601 ANS:
$$-2\sqrt{3} \frac{16\sqrt{21}}{2\sqrt{7}} - 5\sqrt{12} = 8\sqrt{3} - 5\sqrt{4}\sqrt{3} = 8\sqrt{3} - 10\sqrt{3} = -2\sqrt{3}$$
- PTS: 3 REF: 081136ia STA: A.N.3 TOP: Operations with Radicals
- 602 ANS: 2 PTS: 2 REF: 061122ia STA: A.S.14
TOP: Analysis of Data
- 603 ANS: 3
 $3\sqrt{250} = 3\sqrt{25}\sqrt{10} = 15\sqrt{10}$
- PTS: 2 REF: 061106ia STA: A.N.2 TOP: Simplifying Radicals
- 604 ANS: 2
 $\tan ABC = \frac{\text{opposite}}{\text{adjacent}} = \frac{5}{12}$
- PTS: 2 REF: 081112ia STA: A.A.42 TOP: Trigonometric Ratios
- 605 ANS: 2
 $m = \frac{-A}{B} = \frac{-3}{-7} = \frac{3}{7}$
- PTS: 2 REF: 011122ia STA: A.A.37 TOP: Slope
- 606 ANS:
 $-6a + 42$. distributive
- PTS: 2 REF: 061032ia STA: A.N.1 TOP: Properties of Reals

607 ANS:

6, 8, 10. Three consecutive even integers are x , $x + 2$ and $x + 4$. $(x + 2)(x + 4) = 10x + 20$

$$x^2 + 6x + 8 = 10x + 20$$

$$x^2 - 4x - 12 = 0$$

$$(x - 6)(x + 2) = 0$$

$$x = 6$$

PTS: 4 REF: 011039ia STA: A.A.8 TOP: Writing Quadratics

608 ANS: 3 PTS: 2 REF: 011103ia STA: A.S.12

TOP: Scatter Plots

609 ANS:

12, 7. Both the median and the mode will increase.

PTS: 3 REF: 061134ia STA: A.S.16 TOP: Central Tendency

610 ANS:

$$y = \frac{3}{4}x + 10. \quad y = mx + b$$

$$4 = \frac{3}{4}(-8) + b$$

$$4 = -6 + b$$

$$10 = b$$

PTS: 3 REF: 011134ia STA: A.A.34 TOP: Writing Linear Equations

611 ANS: 4 PTS: 2 REF: 081025ia STA: A.G.4

TOP: Families of Functions

612 ANS: 3 PTS: 2 REF: 061011ia STA: A.S.2

TOP: Analysis of Data

613 ANS: 4 PTS: 2 REF: 011020ia STA: A.A.12

TOP: Multiplication of Powers

614 ANS: 4

$${}_5P_5 = 5 \times 4 \times 3 \times 2 \times 1 = 120$$

PTS: 2 REF: 061109ia STA: A.N.8 TOP: Permutations

615 ANS: 4 PTS: 2 REF: 061111ia STA: A.G.4

TOP: Families of Functions

616 ANS: 1

$$x^2 - 36 = 5x$$

$$x^2 - 5x - 36 = 0$$

$$(x - 9)(x + 4) = 0$$

$$x = 9$$

PTS: 2 REF: 061020ia STA: A.A.8 TOP: Writing Quadratics

617 ANS: 3

$$\frac{2+x}{5x} - \frac{x-2}{5x} = \frac{2+x-x+2}{5x} = \frac{4}{5x}$$

PTS: 2

REF: 081027ia

STA: A.A.17

TOP: Addition and Subtraction of Rationals

618 ANS:

$$\frac{4}{12} \times \frac{2}{11} \times \frac{1}{10} = \frac{8}{1320} \quad \frac{6}{12} \times \frac{5}{11} \times \frac{4}{10} + \frac{4}{12} \times \frac{3}{11} \times \frac{2}{10} = \frac{120}{1320} + \frac{24}{1320} = \frac{144}{1320}$$

PTS: 4

REF: 081137ia

STA: A.S.23

TOP: Theoretical Probability

KEY: dependent events

619 ANS: 3

$$2(1)+3=5$$

PTS: 2

REF: 061007ia

STA: A.A.39

TOP: Linear Equations

620 ANS: 2

$$20000(.88)^3 = 13629.44$$

PTS: 2

REF: 061124ia

STA: A.A.9

TOP: Exponential Functions

621 ANS: 1

$$4y - 2x = 0$$

$$4(-1) - 2(-2) = 0$$

$$-4 + 4 = 0$$

PTS: 2

REF: 011021ia

STA: A.A.39

TOP: Identifying Points on a Line

622 ANS:

$$bc + ac = ab$$

$$c(b + a) = ab$$

$$c = \frac{ab}{b+a}$$

PTS: 2

REF: 081131ia

STA: A.A.23

TOP: Transforming Formulas

623 ANS:

$$\frac{m}{5} + \frac{3(m-1)}{2} = 2(m-3)$$

$$\frac{2m}{10} + \frac{15(m-1)}{10} = 2m - 6$$

$$\frac{17m-15}{10} = 2m-6$$

$$17m-15 = 20m-60$$

$$45 = 3m$$

$$15 = m$$

PTS: 4 REF: 081139ia STA: A.A.25

TOP: Solving Equations with Fractional Expressions

624 ANS: 1 PTS: 2 REF: 061024ia STA: A.A.17

TOP: Addition and Subtraction of Rationals

625 ANS: 3

$$V = \pi r^2 h = \pi \cdot 5^2 \cdot 2.3 \approx 180.6$$

PTS: 2 REF: 081105ia STA: A.G.2 TOP: Volume

626 ANS: 4 PTS: 2 REF: 011016ia STA: A.A.23

TOP: Transforming Formulas

627 ANS: 2 PTS: 2 REF: 011019ia STA: A.S.12

TOP: Scatter Plots

628 ANS: 2

$$\sin 57 = \frac{x}{8}$$

$$x \approx 6.7$$

PTS: 2 REF: 061108ia STA: A.A.44 TOP: Using Trigonometry to Find a Side

629 ANS: 2

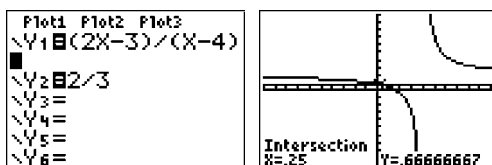

$$\frac{2x-3}{x-4} = \frac{2}{3}$$

$$3(2x-3) = 2(x-4)$$

$$6x-9 = 2x-8$$

$$4x = 1$$

$$x = \frac{1}{4}$$

PTS: 2 REF: 081012ia STA: A.A.26 TOP: Solving Rationals

630 ANS: 2 PTS: 2 REF: 011022ia STA: A.A.19

TOP: Factoring the Difference of Perfect Squares

- 631 ANS: 2 PTS: 2 REF: 061113ia STA: A.G.5
TOP: Graphing Quadratic Functions
- 632 ANS: 2 PTS: 2 REF: 081106ia STA: A.S.6
TOP: Box-and-Whisker Plots
- 633 ANS: 3
 $75 - 15 = 60$
- PTS: 2 REF: 011113ia STA: A.S.6 TOP: Box-and-Whisker Plots
- 634 ANS: 4
 $\frac{9.2 \times 10^6}{2.3 \times 10^2} = 4 \times 10^4$
- PTS: 2 REF: 081006ia STA: A.N.4 TOP: Operations with Scientific Notation
- 635 ANS: 2 PTS: 2 REF: 061023ia STA: A.A.23
TOP: Transforming Formulas
- 636 ANS: 3
 $\sqrt{72} - 3\sqrt{2} = \sqrt{36} \sqrt{2} - 3\sqrt{2} = 6\sqrt{2} - 3\sqrt{2} = 3\sqrt{2}$
- PTS: 2 REF: 061008ia STA: A.N.3 TOP: Operations with Radicals
KEY: subtraction
- 637 ANS: 3 PTS: 2 REF: 081117ia STA: A.A.29
TOP: Set Theory
- 638 ANS: 4 PTS: 2 REF: 011025ia STA: A.A.17
TOP: Addition and Subtraction of Rationals
- 639 ANS: 4
In (4), each element in the domain corresponds to a unique element in the range.
- PTS: 2 REF: 011105ia STA: A.G.3 TOP: Defining Functions
KEY: ordered pairs
- 640 ANS: 3 PTS: 2 REF: 061017ia STA: A.S.11
TOP: Quartiles and Percentiles
- 641 ANS: 1
The slope of $2x - 4y = 16$ is $\frac{-A}{B} = \frac{-2}{-4} = \frac{1}{2}$
- PTS: 2 REF: 011026ia STA: A.A.38 TOP: Parallel and Perpendicular Lines
- 642 ANS: 3 PTS: 2 REF: 061003ia STA: A.A.13
TOP: Addition and Subtraction of Polynomials KEY: addition
- 643 ANS: 3 PTS: 2 REF: 081103ia STA: A.A.30
TOP: Set Theory
- 644 ANS: 3 PTS: 2 REF: 081009ia STA: A.A.30
TOP: Set Theory

645 ANS:

$$41.8. \sin x = \frac{8}{12}$$

$$A \approx 41.8$$

PTS: 3 REF: 081135ia STA: A.A.43 TOP: Using Trigonometry to Find an Angle

646 ANS: 2 PTS: 2 REF: 011012ia STA: A.G.9

TOP: Quadratic-Linear Systems

647 ANS: 4 PTS: 2 REF: 081022ia STA: A.A.29

TOP: Set Theory

648 ANS: 4

$$SA = 2lw + 2hw + 2lh = 2(2)(3) + 2(4)(3) + 2(2)(4) = 52$$

PTS: 2 REF: 011029ia STA: A.G.2 TOP: Surface Area

649 ANS: 3 PTS: 2 REF: 081017a STA: A.S.14

TOP: Analysis of Data

650 ANS:

$$0.029. \frac{[2\pi(5.1)^2 + 2\pi(5.1)(15.1)] - [2\pi(5)^2 + 2\pi(5)(15)]}{2\pi(5.1)^2 + 2\pi(5.1)(15.1)} \approx \frac{647.294 - 628.319}{647.294} \approx 0.029$$

PTS: 4 REF: 011137ia STA: A.M.3 TOP: Error

KEY: volume and surface area

651 ANS:

$$2(x+3)(x-4) + 2(5)(x-4) + 2(x+3)(5)$$

$$2(x^2 - 4x + 3x - 12) + 10(x-4) + 10(x+3)$$

$$2x^2 - 2x - 24 + 10x - 40 + 10x + 30$$

$$2x^2 + 18x - 34$$

PTS: 3 REF: 061136ia STA: A.G.2 TOP: Surface Area

652 ANS: 3

$$\frac{x}{3} + \frac{x+1}{2} = x$$

$$\frac{2x + 3(x+1)}{6} = x$$

$$5x + 3 = 6x$$

$$3 = x$$

PTS: 2 REF: 061019ia STA: A.A.25

TOP: Solving Equations with Fractional Expressions

653 ANS: 1 PTS: 2 REF: 081102ia STA: A.S.12

TOP: Scatter Plots

654 ANS: 4

$$-6x - 17 \geq 8x + 25$$

$$-42 \geq 14x$$

$$-3 \geq x$$

PTS: 2

REF: 081121ia

STA: A.A.24

TOP: Solving Inequalities

655 ANS: 1

PTS: 2

REF: 061005ia

STA: A.G.10

TOP: Identifying the Vertex of a Quadratic Given Graph

656 ANS:

$$-12. 3 \left(\frac{2}{3}x + 3 < -2x - 7 \right)$$

$$x + 9 < -6x - 21$$

$$7x < -30$$

$$x < \frac{-30}{7}$$

PTS: 3

REF: 061034ia

STA: A.A.21

TOP: Interpreting Solutions

657 ANS:

$$77120 + 33500 = 110620 \text{ sq. ft.} \times \frac{1 \text{ acre}}{43560 \text{ sq. ft.}} \approx 2.54 \text{ acres}$$

PTS: 2

REF: 081133ia

STA: A.M.2

TOP: Conversions

KEY: dimensional analysis

658 ANS: 1

PTS: 2

REF: 061103ia

STA: A.A.12

TOP: Division of Powers

659 ANS: 1

$$2(x - 4) = 4(2x + 1)$$

$$2x - 8 = 8x + 4$$

$$-12 = 6x$$

$$-2 = x$$

PTS: 2

REF: 011106ia

STA: A.A.22

TOP: Solving Equations

660 ANS:

$$0.65x + 35 \leq 45$$

$$0.65x \leq 10$$

$$x \leq 15$$

PTS: 3

REF: 061135ia

STA: A.A.6

TOP: Modeling Inequalities

661 ANS:

$$-3\sqrt{48} = -3\sqrt{16}\sqrt{3} = -12\sqrt{3}$$

PTS: 2

REF: 081033ia

STA: A.N.2

TOP: Simplifying Radicals

- 662 ANS: 2 PTS: 2 REF: 061121ia STA: A.A.3
TOP: Expressions
- 663 ANS: 3
$$\cos A = \frac{\text{adjacent}}{\text{hypotenuse}} = \frac{15}{17}$$
- PTS: 2 REF: 011008ia STA: A.A.42 TOP: Trigonometric Ratios
- 664 ANS: 1
$$\sin x = \frac{\text{opposite}}{\text{hypotenuse}} = \frac{28}{53}$$
- PTS: 2 REF: 011109ia STA: A.A.42 TOP: Trigonometric Ratios
- 665 ANS: 4
$$\frac{7}{12x} - \frac{y}{6x^2} = \frac{42x^2 - 12xy}{72x^3} = \frac{6x(7x - 2y)}{72x^3} = \frac{7x - 2y}{12x^2}$$
- PTS: 2 REF: 061129ia STA: A.A.17 TOP: Addition and Subtraction of Rationals
- 666 ANS: 4 PTS: 2 REF: 081011ia STA: A.A.5
TOP: Modeling Equations
- 667 ANS: 1
$$\frac{2x}{3} + \frac{1}{2} = \frac{5}{6}$$

$$\frac{2x}{3} = \frac{1}{3}$$

$$6x = 3$$

$$x = \frac{1}{2}$$
- PTS: 2 REF: 011112ia STA: A.A.25
TOP: Solving Equations with Fractional Expressions
- 668 ANS: 4 PTS: 2 REF: 061016ia STA: A.A.2
TOP: Expressions
- 669 ANS:
$$\sin x = \frac{30}{50}$$

$$x = \sin^{-1} \frac{3}{5}$$

$$x \approx 37$$
- PTS: 2 REF: 061033ia STA: A.A.43 TOP: Using Trigonometry to Find an Angle

670 ANS: 3

$$m = \frac{7-3}{-3-3} = \frac{4}{-6} = -\frac{2}{3} \quad y = mx + b$$

$$3 = -\frac{2}{3}(3) + b$$

$$3 = -2 + b$$

$$5 = b$$

PTS: 2 REF: 011013ia STA: A.A.35 TOP: Writing Linear Equations

671 ANS: 2

$$R = 0.5^{d-1}$$

PTS: 2 REF: 011006ia STA: A.A.9 TOP: Exponential Functions

672 ANS:

(1) Distributive; (2) Commutative

PTS: 2 REF: 061132ia STA: A.N.1 TOP: Identifying Properties

673 ANS: 4

The other situations are quantitative.

PTS: 2 REF: 081122ia STA: A.S.1 TOP: Analysis of Data

674 ANS: 2

PTS: 2 REF: 081014ia STA: A.A.36

TOP: Parallel and Perpendicular Lines

675 ANS: 1

$$1P + 2C = 5$$

$$1P + 4C = 6$$

$$2C = 1$$

$$C = 0.5$$

PTS: 2 REF: 011003ia STA: A.A.7 TOP: Writing Linear Systems

676 ANS: 4

PTS: 2 REF: 061130ia STA: A.A.13

TOP: Addition and Subtraction of Polynomials KEY: subtraction

677 ANS: 4

PTS: 2 REF: 061001ia STA: A.A.30

TOP: Set Theory

678 ANS: 4

PTS: 2 REF: 061018ia STA: A.A.12

TOP: Division of Powers

679 ANS: 1

$$x = \frac{-b}{2a} = \frac{-6}{2(-1)} = 3.$$

PTS: 2 REF: 011127ia STA: A.A.41

TOP: Identifying the Vertex of a Quadratic Given Equation

680 ANS: 4

PTS: 2 REF: 011102ia STA: A.G.9

TOP: Quadratic-Linear Systems

681 ANS:
 15,600,000, 4,368,000. $10 \times 10 \times 10 \times 26 \times 25 \times 24 = 15,600,000$. $10 \times 9 \times 8 \times 26 \times 25 \times 24 = 11,232,000$.
 $15,600,000 - 11,232,000 = 4,368,000$.

PTS: 4 REF: 011037ia STA: A.N.8 TOP: Permutations

682 ANS: 4 PTS: 2 REF: 011111ia STA: A.G.8
 TOP: Solving Quadratics by Graphing

683 ANS: 4

$$\frac{150}{20} = \frac{x}{30}$$

$$20x = 4500$$

$$x = 225$$

PTS: 2 REF: 081101ia STA: A.N.5 TOP: Direct Variation

684 ANS: 2
 $2000(1 + 0.04)^3 \approx 2249$

PTS: 2 REF: 081124ia STA: A.A.9 TOP: Exponential Functions

685 ANS:
 16. 12 feet equals 4 yards. $4 \times 4 = 16$.

PTS: 2 REF: 011031ia STA: A.M.2 TOP: Conversions
 KEY: dimensional analysis

686 ANS: 4 PTS: 2 REF: 061112ia STA: A.A.36
 TOP: Parallel and Perpendicular Lines

687 ANS:

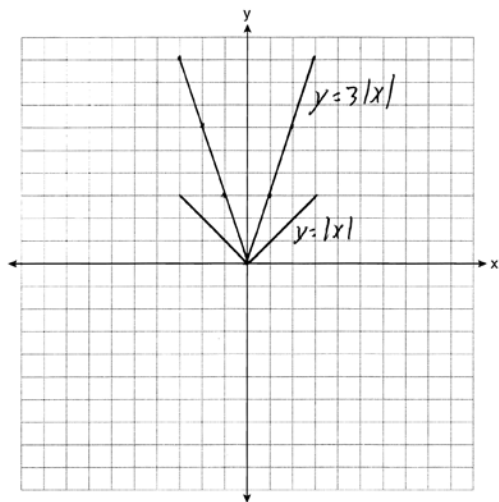

The graph becomes steeper.

PTS: 3 REF: 081134ia STA: A.G.5 TOP: Graphing Absolute Value Functions

688 ANS:
 orchestra: $\frac{3}{26} > \frac{4}{36}$

PTS: 2 REF: 011033ia STA: A.S.22 TOP: Theoretical Probability

689 ANS:

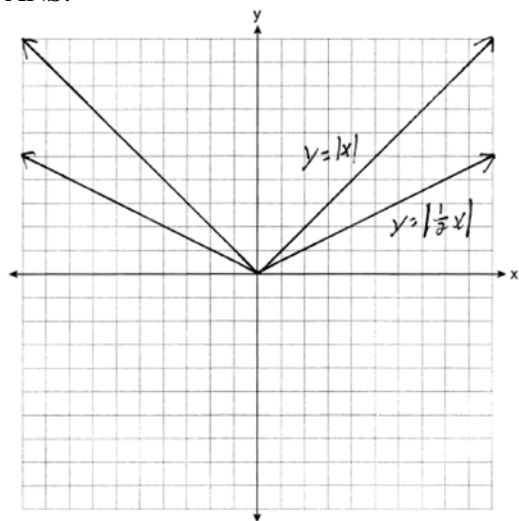

. Graph becomes wider as the coefficient approaches 0.

PTS: 3 REF: 061035ia STA: A.G.5 TOP: Graphing Absolute Value Functions
 690 ANS: 2 PTS: 2 REF: 061127ia STA: A.N.4
 TOP: Operations with Scientific Notation

691 ANS:

$$5. 48 \text{ inches} \times \frac{1 \text{ yard}}{36 \text{ inches}} = \frac{4}{3} \text{ yards} \times \$3.75 = \$5.00$$

PTS: 2 REF: 011131ia STA: A.M.2 TOP: Conversions
 KEY: dimensional analysis

692 ANS:

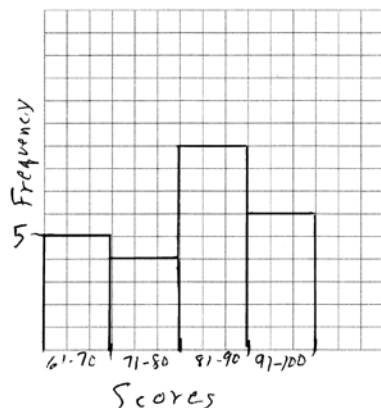

PTS: 2 REF: 081132ia STA: A.S.5
 TOP: Frequency Histograms, Bar Graphs and Tables KEY: frequency histograms
 693 ANS: 1 PTS: 2 REF: 011001ia STA: A.S.6
 TOP: Box-and-Whisker Plots
 694 ANS: 2 PTS: 2 REF: 061115ia STA: A.S.7
 TOP: Scatter Plots
 695 ANS: 4 PTS: 2 REF: 061028ia STA: A.G.6
 TOP: Linear Inequalities

696 ANS: 1

$$\frac{12.8 + 17.2}{3 + 5} = 3.75$$

PTS: 2

REF: 061117ia

STA: A.M.1

TOP: Speed

697 ANS: 3

$$x = \frac{-b}{2a} = \frac{-10}{2(-1)} = 5.$$

PTS: 2

REF: 081018ia

STA: A.A.41

TOP: Identifying the Vertex of a Quadratic Given Equation

698 ANS: 1

$$3(2m - 1) \leq 4m + 7$$

$$6m - 3 \leq 4m + 7$$

$$2m \leq 10$$

$$m \leq 5$$

PTS: 2

REF: 081002ia

STA: A.A.24

TOP: Solving Inequalities

699 ANS:

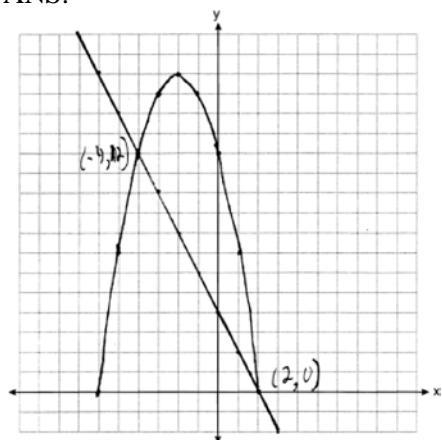

PTS: 4

REF: 061039ia

STA: A.G.9

TOP: Quadratic-Linear Systems

700 ANS: 4

$$s = \frac{d}{t} = \frac{150 \text{ m}}{1.5 \text{ min}} \cdot \frac{60 \text{ min}}{1 \text{ hr}} = 6,000 \frac{\text{m}}{\text{hr}}$$

PTS: 2

REF: 061025ia

STA: A.M.1

TOP: Speed

701 ANS: 1

$$15000(1.2)^{\frac{6}{3}} = 21,600. \quad 21,600 - 15,000 = 6,600$$

PTS: 2

REF: 061030ia

STA: A.A.9

TOP: Exponential Functions

702 ANS: 4

In (4), each element in the domain corresponds to a unique element in the range.

PTS: 2 REF: 011018ia STA: A.G.3 TOP: Defining Functions
 KEY: ordered pairs

703 ANS: 3

$$P(\text{odd}) = \frac{3}{6}, P(\text{prime}) = \frac{3}{6}, P(\text{perfect square}) = \frac{2}{6}, P(\text{even}) = \frac{3}{6}$$

PTS: 2 REF: 061104ia STA: A.S.22 TOP: Geometric Probability

704 ANS: 3

Frequency is not a variable.

PTS: 2 REF: 011014ia STA: A.S.2 TOP: Analysis of Data

705 ANS: 4 PTS: 2 REF: 061013ia STA: A.G.3
 TOP: Defining Functions KEY: graphs

706 ANS: 1

$$2y - 2x = 10 \quad \text{axis of symmetry: } x = \frac{-b}{2a} = \frac{-2}{2(1)} = -1$$

$$2y = 2x + 10$$

$$y = x + 5$$

PTS: 2 REF: 081010ia STA: A.G.9 TOP: Quadratic-Linear Systems

707 ANS:

$$3a^2b^2 - 6a \cdot \frac{45a^4b^3 - 90a^3b}{15a^2b} = \frac{45a^4b^3}{15a^2b} - \frac{90a^3b}{15a^2b} = 3a^2b^2 - 6a$$

PTS: 2 REF: 081031ia STA: A.A.14 TOP: Division of Polynomials

708 ANS: 3

$$x^2 - 9 = 0$$

$$(x + 3)(x - 3) = 0$$

$$x = \pm 3$$

PTS: 2 REF: 061014ia STA: A.A.15 TOP: Undefined Rationals

709 ANS: 4

$$6\sqrt{50} + 6\sqrt{2} = 6\sqrt{25} \sqrt{2} + 6\sqrt{2} = 30\sqrt{2} + 6\sqrt{2} = 36\sqrt{2}$$

PTS: 2 REF: 011024ia STA: A.N.3 TOP: Operations with Radicals
 KEY: addition

710 ANS: 4

$${}_8P_3 = 336$$

PTS: 2 REF: 061026ia STA: A.N.8 TOP: Permutations

711 ANS: 2

$$2(x - 3y = -3)$$

$$2x + y = 8$$

$$2x - 6y = -6$$

$$7y = 14$$

$$y = 2$$

PTS: 2

REF: 081021ia

STA: A.A.10

TOP: Solving Linear Systems

712 ANS: 1

$$7 + 8 + 7 + \frac{12\pi}{2} = 22 + 6\pi$$

PTS: 2

REF: 081128ia

STA: A.G.1

TOP: Compositions of Polygons and Circles

KEY: perimeter

713 ANS: 2

$y - kx = 7$ may be rewritten as $y = kx + 7$

PTS: 2

REF: 061015ia

STA: A.A.38

TOP: Parallel and Perpendicular Lines

714 ANS: 2

$$m = \frac{5-3}{8-1} = \frac{2}{7} \quad y - y_1 = m(x - x_1)$$

$$y - 5 = \frac{2}{7}(x - 8)$$

PTS: 2

REF: 081029ia

STA: A.A.35

TOP: Writing Linear Equations

715 ANS: 3

mean = $81\frac{7}{11}$, median = 81 and mode = 76

PTS: 2

REF: 011118ia

STA: A.S.4

TOP: Central Tendency

716 ANS:

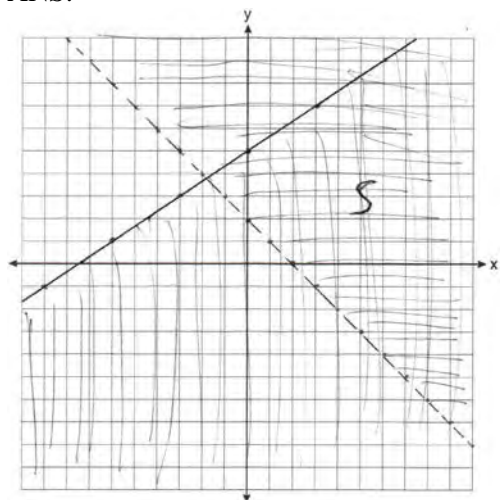

PTS: 4

REF: 011139ia

STA: A.G.7

TOP: Systems of Linear Inequalities

717 ANS:

$$-15, 2 \quad x^2 + 13x - 30 = 0$$

$$(x + 15)(x - 2) = 0$$

$$x = -15, 2$$

PTS: 3

REF: 081036ia

STA: A.A.28

TOP: Roots of Quadratics

718 ANS: 3

PTS: 2

REF: 081001ia

STA: A.S.7

TOP: Scatter Plots

719 ANS: 3

PTS: 2

REF: 011104ia

STA: A.A.1

TOP: Expressions

720 ANS: 3

$$\frac{(10w^3)^2}{5w} = \frac{100w^6}{5w} = 20w^5$$

PTS: 2

REF: 011124ia

STA: A.A.12

TOP: Powers of Powers

721 ANS: 2

$$x^2 - 5x + 6 = 0$$

$$(x - 3)(x - 2) = 0$$

$$x = 3 \quad x = 2$$

PTS: 2

REF: 081120ia

STA: A.A.28

TOP: Roots of Quadratics

722 ANS:

$$4, -5. \quad \frac{x+2}{6} = \frac{3}{x-1}$$

$$(x+2)(x-1) = 18$$

$$x^2 - x + 2x - 2 = 18$$

$$x^2 + x - 20 = 0$$

$$(x+5)(x-4) = 0$$

$$x = -5 \text{ or } 4$$

PTS: 3

REF: 011136ia

STA: A.A.26

TOP: Solving Rationals

723 ANS:

$$24,435.19. \quad 30000(.95)^4 \approx 24435.19$$

PTS: 4

REF: 011138ia

STA: A.A.9

TOP: Exponential Functions

724 ANS: 1

PTS: 2

REF: 081015ia

STA: A.G.5

TOP: Graphing Quadratic Functions

725 ANS: 3

PTS: 2

REF: 081008ia

STA: A.A.19

TOP: Factoring the Difference of Perfect Squares

726 ANS: 2

$$\left| \frac{55.42 - 50.27}{55.42} \right| \approx 0.093$$

PTS: 2

REF: 081023ia

STA: A.M.3

TOP: Error

KEY: area

727 ANS: 2

$$\tan A = \frac{\text{opposite}}{\text{adjacent}} = \frac{14}{48}$$

PTS: 2

REF: 061009ia

STA: A.A.42

TOP: Trigonometric Ratios

728 ANS: 4

$$5(x+4) = 5x + 20$$

PTS: 2

REF: 081013ia

STA: A.A.1

TOP: Expressions

729 ANS: 3

PTS: 2

REF: 061101ia

STA: A.A.19

TOP: Factoring the Difference of Perfect Squares

730 ANS: 2

$$\sqrt{18.4^2 - 7^2} \approx 17$$

PTS: 2

REF: 011107ia

STA: A.A.45

TOP: Pythagorean Theorem

731 ANS: 1

$$y = mx + b$$

$$5 = (-2)(1) + b$$

$$b = 7$$

PTS: 2 REF: 081108ia STA: A.A.34 TOP: Writing Linear Equations

732 ANS:

(T,J,F), (T,J,N), (T,K,F), (T,K,N), (T,C,F), (T,C,N), (B,J,F), (B,J,N), (B,K,F), (B,K,N), (B,C,F), (B,C,N), (S,J,F), (S,J,N), (S,K,F), (S,K,N), (S,C,F), (S,C,N). 3, 12.

PTS: 4 REF: 061138ia STA: A.S.19 TOP: Sample Space

733 ANS: 4

$$5 \times 2 \times 3 = 30$$

PTS: 2 REF: 061002ia STA: A.N.7 TOP: Multiplication Counting Principle

734 ANS:

$$0.102 \cdot \frac{(5.3 \times 8.2 \times 4.1) - (5 \times 8 \times 4)}{5.3 \times 8.2 \times 4.1} = \frac{178.16 - 160}{178.16} = 0.102$$

PTS: 3 REF: 011036ia STA: A.M.3 TOP: Error

KEY: volume and surface area

735 ANS: 3

$$P(S) \cdot P(M) = P(S \text{ and } M)$$

$$\frac{3}{5} \cdot P(M) = \frac{3}{10}$$

$$P(M) = \frac{1}{2}$$

PTS: 2 REF: 081024ia STA: A.S.23 TOP: Theoretical Probability

KEY: independent events

736 ANS:

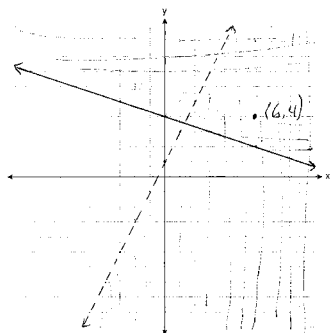

PTS: 4 REF: 081037ia STA: A.G.7 TOP: Systems of Linear Inequalities

737 ANS: 3

The age of a child does not cause the number of siblings he has, or vice versa.

PTS: 2 REF: 011030ia STA: A.S.14 TOP: Analysis of Data

738 ANS:

$$-\frac{9}{4} \cdot \frac{3}{4} = \frac{-(x+11)}{4x} + \frac{1}{2x}$$

$$\frac{3}{4} = \frac{-x-11}{4x} + \frac{2}{4x}$$

$$\frac{3}{4} = \frac{-x-9}{4x}$$

$$12x = -4x - 36$$

$$16x = -36$$

$$x = -\frac{9}{4}$$

PTS: 4

REF: 061137ia

STA: A.A.26

TOP: Solving Rationals

739 ANS: 3

$${}_6P_4 = 360$$

PTS: 2

REF: 081028ia

STA: A.N.8

TOP: Permutations

740 ANS: 1

PTS: 2

REF: 011126ia

STA: A.A.13

TOP: Addition and Subtraction of Polynomials

KEY: subtraction

741 ANS: 2

$$A = lw + lw + \frac{\pi r^2}{4} = 5 \cdot 3 + 5 \cdot 3 + \frac{\pi \cdot 3^2}{4} \approx 37$$

PTS: 2

REF: 011123ia

STA: A.G.1

TOP: Compositions of Polygons and Circles

KEY: area