

JMAP REGENTS AT RANDOM

The NY Integrated Algebra Regents Exams
Fall 2007-August 2013

www.jmap.org

Integrated Algebra Regents at Random

- 1 The expression $x^2 - 36y^2$ is equivalent to
- 1) $(x - 6y)(x - 6y)$
 - 2) $(x - 18y)(x - 18y)$
 - 3) $(x + 6y)(x - 6y)$
 - 4) $(x + 18y)(x - 18y)$

- 2 Ms. Mosher recorded the math test scores of six students in the table below.

Student	Student Score
Andrew	72
John	80
George	85
Amber	93
Betty	78
Roberto	80

Determine the mean of the student scores, to the *nearest tenth*. Determine the median of the student scores. Describe the effect on the mean and the median if Ms. Mosher adds 5 bonus points to each of the six students' scores.

- 3 The legs of an isosceles right triangle each measure 10 inches. What is the length of the hypotenuse of this triangle, to the *nearest tenth of an inch*?
- 1) 6.3
 - 2) 7.1
 - 3) 14.1
 - 4) 17.1

- 4 As shown in the diagram below, a ladder 5 feet long leans against a wall and makes an angle of 65° with the ground. Find, to the *nearest tenth of a foot*, the distance from the wall to the base of the ladder.

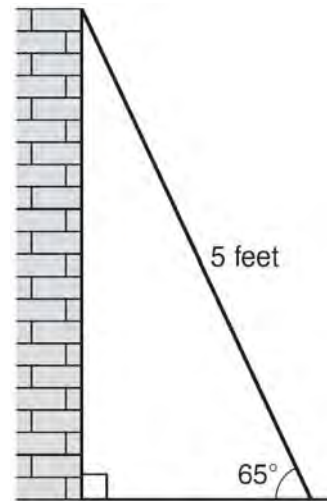

- 5 Which linear equation represents a line containing the point $(1, 3)$?
- 1) $x + 2y = 5$
 - 2) $x - 2y = 5$
 - 3) $2x + y = 5$
 - 4) $2x - y = 5$
- 6 Which equation illustrates the associative property?
- 1) $x + y + z = x + y + z$
 - 2) $x(y + z) = xy + xz$
 - 3) $x + y + z = z + y + x$
 - 4) $(x + y) + z = x + (y + z)$

- 7 Megan and Bryce opened a new store called the Donut Pit. Their goal is to reach a profit of \$20,000 in their 18th month of business. The table and scatter plot below represent the profit, P , in thousands of dollars, that they made during the first 12 months.

t (months)	P (profit, in thousands of dollars)
1	3.0
2	2.5
3	4.0
4	5.0
5	6.5
6	5.5
7	7.0
8	6.0
9	7.5
10	7.0
11	9.0
12	9.5

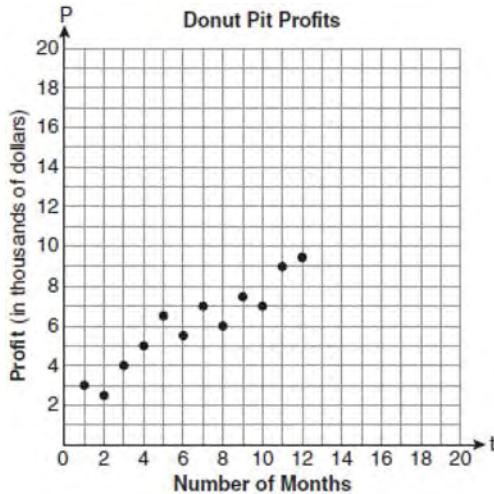

Draw a reasonable line of best fit. Using the line of best fit, predict whether Megan and Bryce will reach their goal in the 18th month of their business. Justify your answer.

8 The expression $\frac{12w^9y^3}{-3w^3y^3}$ is equivalent to

- 1) $-4w^6$
 - 2) $-4w^3y$
 - 3) $9w^6$
 - 4) $9w^3y$
- 9 What is an equation of the axis of symmetry of the parabola represented by $y = -x^2 + 6x - 4$?
- 1) $x = 3$
 - 2) $y = 3$
 - 3) $x = 6$
 - 4) $y = 6$
- 10 In interval notation, the set of all real numbers greater than -6 and less than or equal to 14 is represented by
- 1) $(-6, 14)$
 - 2) $[-6, 14)$
 - 3) $(-6, 14]$
 - 4) $[-6, 14]$

- 11 What is the result when $2x^2 + 3xy - 6$ is subtracted from $x^2 - 7xy + 2$?
- 1) $-x^2 - 10xy + 8$
 - 2) $x^2 + 10xy - 8$
 - 3) $-x^2 - 4xy - 4$
 - 4) $x^2 - 4xy - 4$

12 Which equation represents a line parallel to the graph of $2x - 4y = 16$?

- 1) $y = \frac{1}{2}x - 5$
- 2) $y = -\frac{1}{2}x + 4$
- 3) $y = -2x + 6$
- 4) $y = 2x + 8$

13 The figure shown below is composed of two rectangles and a quarter circle.

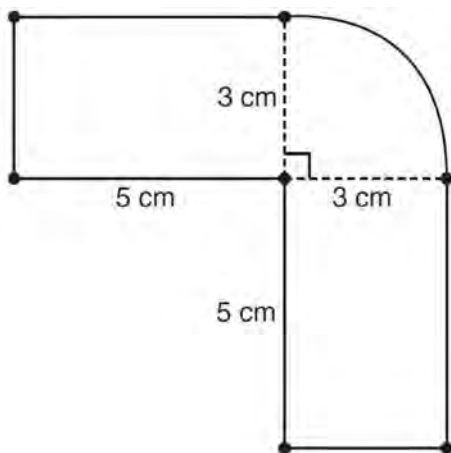

What is the area of this figure, to the *nearest square centimeter*?

- 1) 33
- 2) 37
- 3) 44
- 4) 58

14 Express in simplest form:

$$\frac{x^2 + 9x + 14}{x^2 - 49} \div \frac{3x + 6}{x^2 + x - 56}$$

15 What are the vertex and the axis of symmetry of the parabola shown in the graph below?

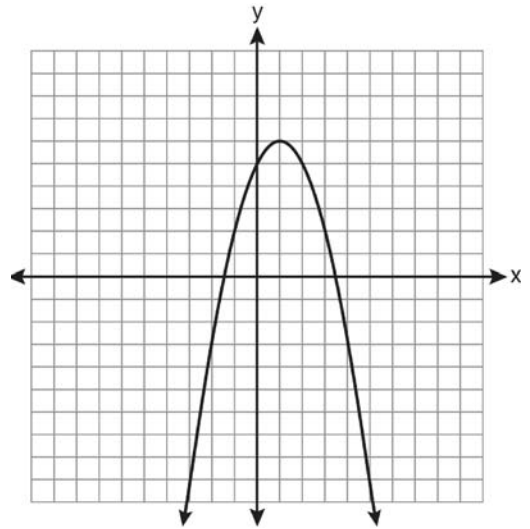

- 1) vertex: (1, 6); axis of symmetry: $y = 1$
- 2) vertex: (1, 6); axis of symmetry: $x = 1$
- 3) vertex: (6, 1); axis of symmetry: $y = 1$
- 4) vertex: (6, 1); axis of symmetry: $x = 1$

16 The current student population of the Brentwood Student Center is 2,000. The enrollment at the center increases at a rate of 4% each year. To the *nearest whole number*, what will the student population be closest to in 3 years'?

- 1) 2,240
- 2) 2,250
- 3) 5,488
- 4) 6,240

- 17 The diagram below shows a cumulative frequency histogram of the students' test scores in Ms. Wedow's algebra class.

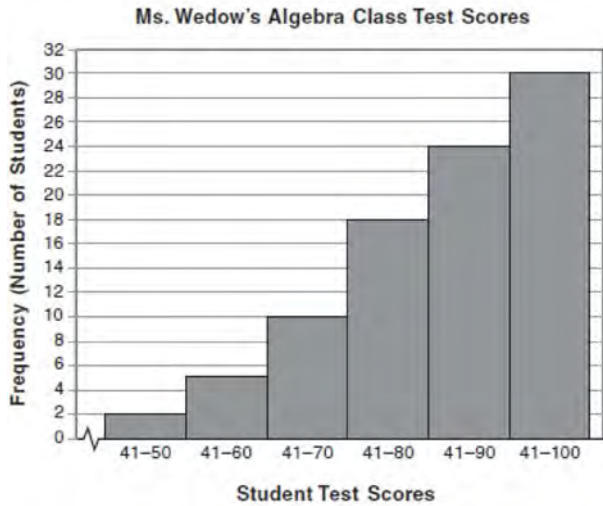

Determine the total number of students in the class. Determine how many students scored higher than 70. State which *ten-point interval* contains the median. State which *two ten-point intervals* contain the same frequency.

- 18 A plastic storage box in the shape of a rectangular prism has a length of $x + 3$, a width of $x - 4$, and a height of 5. Represent the surface area of the box as a trinomial in terms of x .

- 19 A hiker walked 12.8 miles from 9:00 a.m. to noon. He walked an additional 17.2 miles from 1:00 p.m. to 6:00 p.m. What is his average rate for the entire walk, in miles per hour?
- 1) 3.75
 - 2) 3.86
 - 3) 4.27
 - 4) 7.71

- 20 Which interval notation represents the set of all numbers greater than or equal to 5 and less than 12?
- 1) $[5, 12)$
 - 2) $(5, 12]$
 - 3) $(5, 12)$
 - 4) $[5, 12]$

- 21 An example of an algebraic expression is
- 1) $y = mx + b$
 - 2) $3x + 4y - 7$
 - 3) $2x + 3y \leq 18$
 - 4) $(x + y)(x - y) = 25$

- 22 Given: $A = \{3, 6, 9, 12, 15\}$
 $B = \{2, 4, 6, 8, 10, 12\}$
 What is the union of sets A and B ?
- 1) $\{6\}$
 - 2) $\{6, 12\}$
 - 3) $\{2, 3, 4, 8, 9, 10, 15\}$
 - 4) $\{2, 3, 4, 6, 8, 9, 10, 12, 15\}$

- 23 Which verbal expression is represented by $\frac{1}{2}(n - 3)$?
- 1) one-half n decreased by 3
 - 2) one-half n subtracted from 3
 - 3) the difference of one-half n and 3
 - 4) one-half the difference of n and 3

- 24 Which scatter plot shows the relationship between x and y if x represents a student score on a test and y represents the number of incorrect answers a student received on the same test?

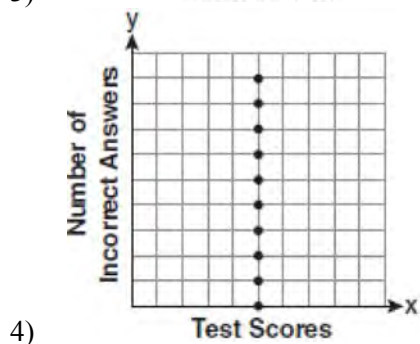
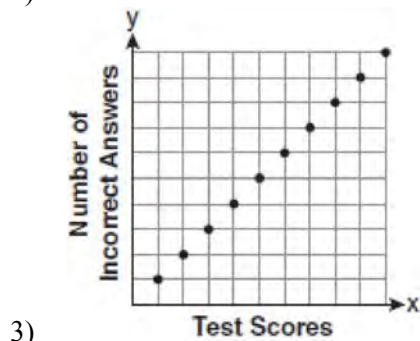
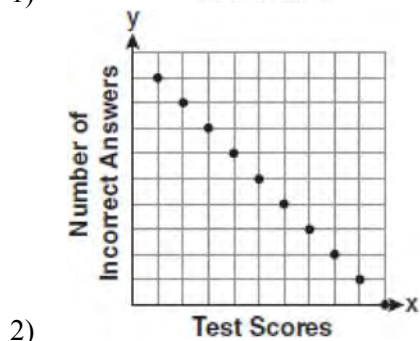
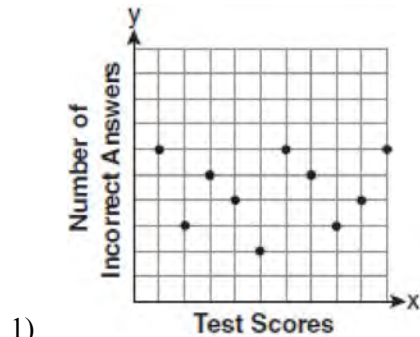

- 25 Alexis calculates the surface area of a gift box as 600 square inches. The actual surface area of the gift box is 592 square inches. Find the relative error of Alexis' calculation expressed as a decimal to the *nearest thousandth*.

- 26 How many different sandwiches consisting of one type of cheese, one condiment, and one bread choice can be prepared from five types of cheese, two condiments, and three bread choices?

- 1) 10
- 2) 13
- 3) 15
- 4) 30

- 27 Which value of x is the solution of $\frac{2x-3}{x-4} = \frac{2}{3}$?

- 1) $-\frac{1}{4}$
- 2) $\frac{1}{4}$
- 3) -4
- 4) 4

- 28 The length of a rectangle is 3 inches more than its width. The area of the rectangle is 40 square inches. What is the length, in inches, of the rectangle?

- 1) 5
- 2) 8
- 3) 8.5
- 4) 11.5

- 29 The algebraic expression $\frac{x-2}{x^2-9}$ is undefined when x is
- 1) 0
 - 2) 2
 - 3) 3
 - 4) 9

- 30 In right triangle ABC shown below, $AB = 18.3$ and $BC = 11.2$.

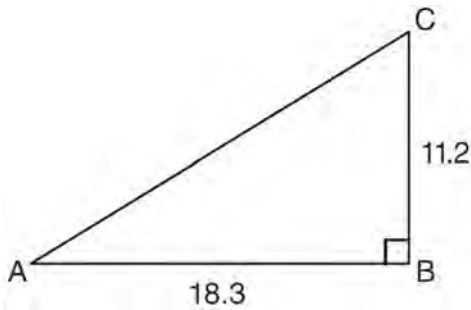

What is the measure of $\angle A$, to the nearest tenth of a degree?

- 1) 31.5
 - 2) 37.7
 - 3) 52.3
 - 4) 58.5
- 31 The quotient of (9.2×10^6) and (2.3×10^2) expressed in scientific notation is
- 1) 4,000
 - 2) 40,000
 - 3) 4×10^3
 - 4) 4×10^4
- 32 The members of the senior class are planning a dance. They use the equation $r = pn$ to determine the total receipts. What is n expressed in terms of r and p ?
- 1) $n = r + p$
 - 2) $n = r - p$
 - 3) $n = \frac{p}{r}$
 - 4) $n = \frac{r}{p}$
- 33 Which equation represents a line parallel to the y -axis?
- 1) $x = y$
 - 2) $x = 4$
 - 3) $y = 4$
 - 4) $y = x + 4$
- 34 How many different four-letter arrangements are possible with the letters G, A, R, D, E, N if each letter may be used only once?
- 1) 15
 - 2) 24
 - 3) 360
 - 4) 720
- 35 A survey is being conducted to determine which school board candidate would best serve the Yonkers community. Which group, when randomly surveyed, would likely produce the most bias?
- 1) 15 employees of the Yonkers school district
 - 2) 25 people driving past Yonkers High School
 - 3) 75 people who enter a Yonkers grocery store
 - 4) 100 people who visit the local Yonkers shopping mall

Integrated Algebra Regents Exam Questions at Random
www.jmap.org

- 36 An outfit Jennifer wears to school consists of a top, a bottom, and shoes. Possible choices are listed below.

Tops: T-shirt, blouse, sweater

Bottoms: jeans, skirt, capris

Shoes: flip-flops, sneakers

List the sample space or draw a tree diagram to represent all possible outfits consisting of one type of top, one type of bottom, and one pair of shoes. Determine how many different outfits contain jeans and flip-flops. Determine how many different outfits do *not* include a sweater.

- 37 What is the value of the expression $(a^3 + b^0)^2$ when $a = -2$ and $b = 4$?
- 1) 64
 - 2) 49
 - 3) -49
 - 4) -64

- 38 The data in the table below are graphed, and the slope is examined.

x	y
0.5	9.0
1	8.75
1.5	8.5
2	8.25
2.5	8.0

The rate of change represented in this table can be described as

- 1) negative
- 2) positive
- 3) undefined
- 4) zero

- 39 Debbie solved the linear equation $3(x + 4) - 2 = 16$ as follows:

[Line 1] $3(x + 4) - 2 = 16$

[Line 2] $3(x + 4) = 18$

[Line 3] $3x + 4 = 18$

[Line 4] $3x = 14$

[Line 5] $x = 4\frac{2}{3}$

She made an error between lines

- 1) 1 and 2
- 2) 2 and 3
- 3) 3 and 4
- 4) 4 and 5

- 40 The diagram below shows right triangle ABC .

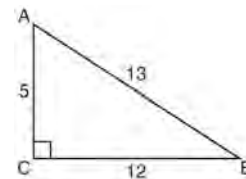

Which ratio represents the tangent of $\angle ABC$?

- 1) $\frac{5}{13}$
- 2) $\frac{5}{12}$
- 3) $\frac{12}{13}$
- 4) $\frac{12}{5}$

- 41 How many different ways can five books be arranged on a shelf?
- 1) 5
 - 2) 15
 - 3) 25
 - 4) 120

- 42 The test scores for 18 students in Ms. Mosher's class are listed below:
- 86, 81, 79, 71, 58, 87, 52, 71, 87,
 87, 93, 64, 94, 81, 76, 98, 94, 68
- Complete the frequency table below.

Interval	Tally	Frequency
51–60		
61–70		
71–80		
81–90		
91–100		

Draw and label a frequency histogram on the grid below.



- 43 Find the roots of the equation $x^2 - x = 6$ algebraically.

- 44 Which ordered pair is a solution of the system of equations shown in the graph below?

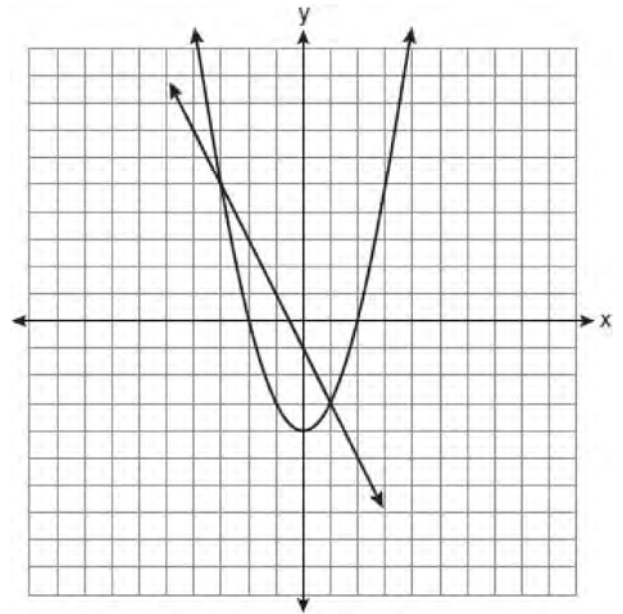

- 1) $(-3, 1)$
- 2) $(-3, 5)$
- 3) $(0, -1)$
- 4) $(0, -4)$

- 45 Which verbal expression can be represented by $2(x - 5)$?
- 1) 5 less than 2 times x
 - 2) 2 multiplied by x less than 5
 - 3) twice the difference of x and 5
 - 4) the product of 2 and x , decreased by 5

- 46 On the set of axes below, graph and label the equations $y = |x|$ and $y = 3|x|$ for the interval $-3 \leq x \leq 3$.

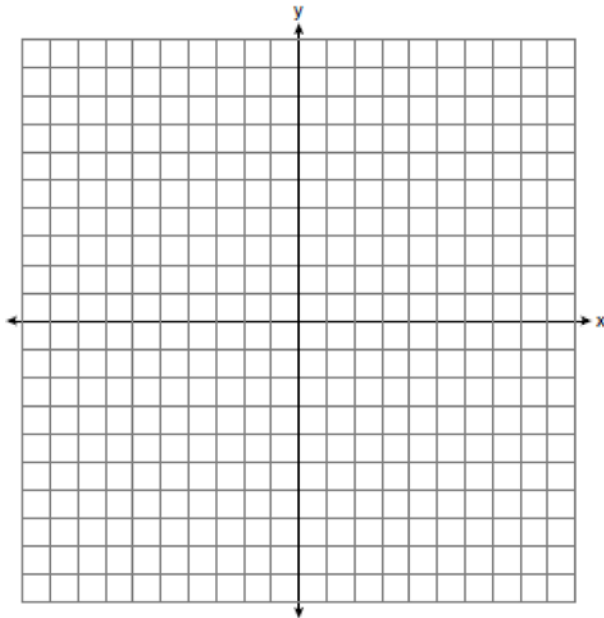

Explain how changing the coefficient of the absolute value from 1 to 3 affects the graph.

- 47 Which situation does *not* describe a causal relationship?
- 1) The higher the volume on a radio, the louder the sound will be.
 - 2) The faster a student types a research paper, the more pages the paper will have.
 - 3) The shorter the distance driven, the less gasoline that will be used.
 - 4) The slower the pace of a runner, the longer it will take the runner to finish the race.

- 48 Ms. Hopkins recorded her students' final exam scores in the frequency table below.

Interval	Tally	Frequency
61–70	###	5
71–80		4
81–90	###	9
91–100	###	6

On the grid below, construct a frequency histogram based on the table.

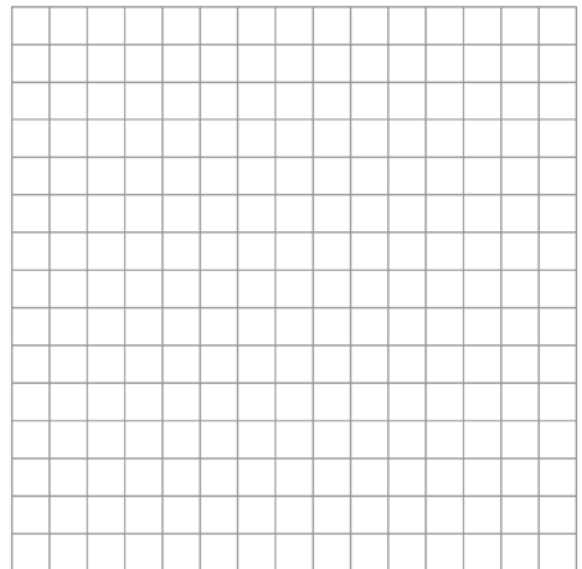

- 49 What is the solution of $3(2m - 1) \leq 4m + 7$?
- 1) $m \leq 5$
 - 2) $m \geq 5$
 - 3) $m \leq 4$
 - 4) $m \geq 4$

- 50 Four hundred licensed drivers participated in the math club's survey on driving habits. The table below shows the number of drivers surveyed in each age group.

Ages of People in Survey on Driving Habits

Age Group	Number of Drivers
16–25	150
26–35	129
36–45	33
46–55	57
56–65	31

Which statement best describes a conclusion based on the data in the table?

- 1) It may be biased because no one younger than 16 was surveyed.
 - 2) It would be fair because many different age groups were surveyed.
 - 3) It would be fair because the survey was conducted by the math club students.
 - 4) It may be biased because the majority of drivers surveyed were in the younger age intervals.
- 51 The number of songs fifteen students have on their MP3 players is:
 120, 124, 132, 145, 200, 255, 260, 292,
 308, 314, 342, 407, 421, 435, 452
 State the values of the minimum, 1st quartile, median, 3rd quartile, and maximum. Using these values, construct a box-and-whisker plot using an appropriate scale on the line below.



- 52 Steve ran a distance of 150 meters in $1\frac{1}{2}$ minutes. What is his speed in meters per hour?
- 1) 6
 - 2) 60
 - 3) 100
 - 4) 6,000
- 53 Sam's grades on eleven chemistry tests were 90, 85, 76, 63, 94, 89, 81, 76, 78, 69, and 97. Which statement is true about the measures of central tendency?
- 1) mean > mode
 - 2) mean < median
 - 3) mode > median
 - 4) median = mean
- 54 Which equation represents a line parallel to the y -axis?
- 1) $y = x$
 - 2) $y = 3$
 - 3) $x = -y$
 - 4) $x = -4$
- 55 Jack wants to replace the flooring in his rectangular kitchen. He calculates the area of the floor to be 12.8 square meters. The actual area of the floor is 13.5 square meters. What is the relative error in calculating the area of the floor, to the *nearest thousandth*?
- 1) 0.051
 - 2) 0.052
 - 3) 0.054
 - 4) 0.055

56 Joseph typed a 1,200-word essay in 25 minutes. At this rate, determine how many words he can type in 45 minutes.

57 Express $\frac{16\sqrt{21}}{2\sqrt{7}} - 5\sqrt{12}$ in simplest radical form.

58 How many square inches of wrapping paper are needed to entirely cover a box that is 2 inches by 3 inches by 4 inches?

- 1) 18
- 2) 24
- 3) 26
- 4) 52

59 What is the sum of $\frac{3}{2x}$ and $\frac{7}{4x}$?

- 1) $\frac{21}{8x^2}$
- 2) $\frac{13}{4x}$
- 3) $\frac{10}{6x}$
- 4) $\frac{13}{8x}$

60 Which algebraic expression represents 15 less than x divided by 9?

- 1) $\frac{x}{9} - 15$
- 2) $9x - 15$
- 3) $15 - \frac{x}{9}$
- 4) $15 - 9x$

61 What is $\frac{2+x}{5x} - \frac{x-2}{5x}$ expressed in simplest form?

- 1) 0
- 2) $\frac{2}{5}$
- 3) $\frac{4}{5x}$
- 4) $\frac{2x+4}{5x}$

62 The scatter plot below represents the relationship between the number of peanuts a student eats and the student's bowling score.

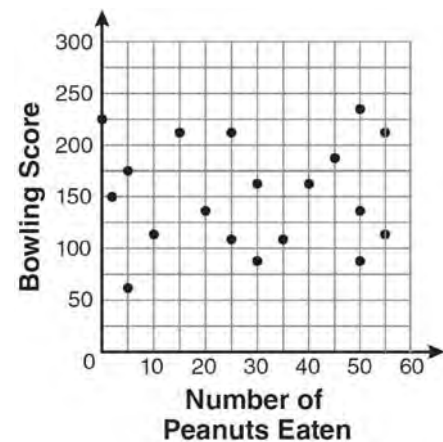

Which conclusion about the scatter plot is valid?

- 1) There is almost no relationship between eating peanuts and bowling score.
- 2) Students who eat more peanuts have higher bowling scores.
- 3) Students who eat more peanuts have lower bowling scores.
- 4) No bowlers eat peanuts.

- 63 The value of the expression $-|a - b|$ when $a = 7$ and $b = -3$ is
- 1) -10
 - 2) 10
 - 3) -4
 - 4) 4

- 64 Mrs. Chen owns two pieces of property. The areas of the properties are 77,120 square feet and 33,500 square feet.

$43,560 \text{ square feet} = 1 \text{ acre}$

Find the total number of acres Mrs. Chen owns, to the *nearest hundredth of an acre*.

- 65 Roberta needs ribbon for a craft project. The ribbon sells for \$3.75 per yard. Find the cost, in dollars, for 48 inches of the ribbon.

- 66 The graphs of the equations $y = 2x - 7$ and $y - kx = 7$ are parallel when k equals
- 1) -2
 - 2) 2
 - 3) -7
 - 4) 7

- 67 Given: $A = \{18, 6, -3, -12\}$
Determine all elements of set A that are in the solution of the inequality $\frac{2}{3}x + 3 < -2x - 7$.

- 68 On the set of axes below, solve the following system of inequalities graphically.

$$y < 2x + 1$$

$$y \geq -\frac{1}{3}x + 4$$

State the coordinates of a point in the solution set.

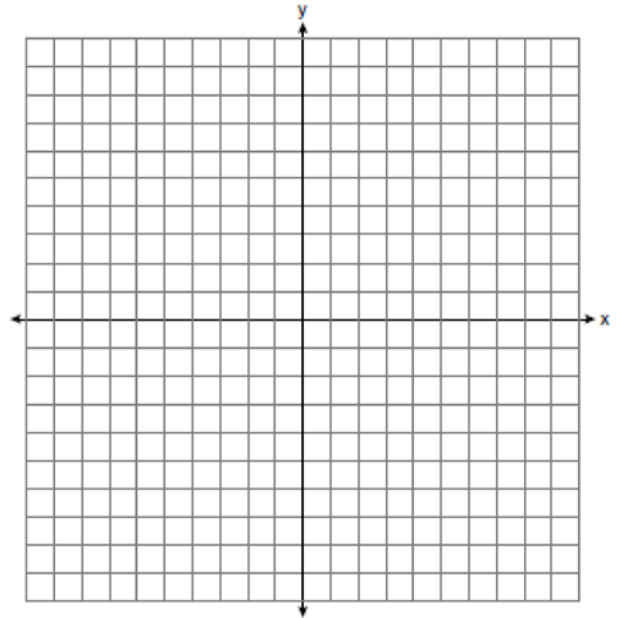

- 69 A right triangle contains a 38° angle whose adjacent side measures 10 centimeters. What is the length of the hypotenuse, to the *nearest hundredth of a centimeter*?
- 1) 7.88
 - 2) 12.69
 - 3) 12.80
 - 4) 16.24

70 Which expression is equivalent to $3^3 \cdot 3^4$?

- 1) 9^{12}
- 2) 9^7
- 3) 3^{12}
- 4) 3^7

71 When $5x + 4y$ is subtracted from $5x - 4y$, the difference is

- 1) 0
- 2) $10x$
- 3) $8y$
- 4) $-8y$

72 In a science fiction novel, the main character found a mysterious rock that decreased in size each day. The table below shows the part of the rock that remained at noon on successive days.

Day	Fractional Part of the Rock Remaining
1	1
2	$\frac{1}{2}$
3	$\frac{1}{4}$
4	$\frac{1}{8}$

Which fractional part of the rock will remain at noon on day 7?

- 1) $\frac{1}{128}$
- 2) $\frac{1}{64}$
- 3) $\frac{1}{14}$
- 4) $\frac{1}{12}$

73 A student correctly graphed the parabola shown below to solve a given quadratic equation.

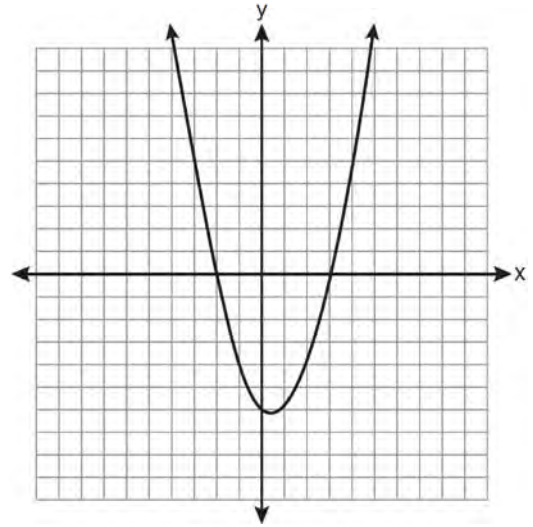

What are the roots of the quadratic equation associated with this graph?

- 1) -6 and 3
- 2) -6 and 0
- 3) -3 and 2
- 4) -2 and 3

74 Which expression represents $36x^2 - 100y^6$ factored completely?

- 1) $2(9x + 25y^3)(9x - 25y^3)$
- 2) $4(3x + 5y^3)(3x - 5y^3)$
- 3) $(6x + 10y^3)(6x - 10y^3)$
- 4) $(18x + 50y^3)(18x - 50y^3)$

75 Using his ruler, Howell measured the sides of a rectangular prism to be 5 cm by 8 cm by 4 cm. The actual measurements are 5.3 cm by 8.2 cm by 4.1 cm. Find Howell's relative error in calculating the volume of the prism, to the nearest thousandth.

- 76 The graph of the equation $y = |x|$ is shown in the diagram below.

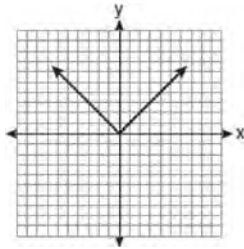

Which diagram could represent a graph of the equation $y = a|x|$ when $-1 < a < 0$?

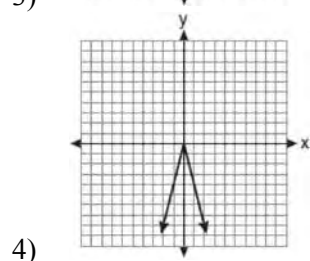
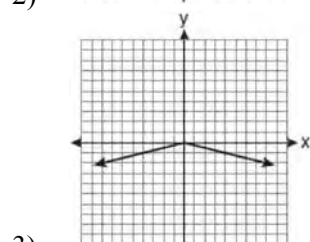
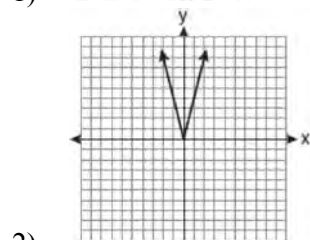
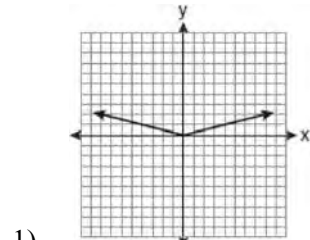

- 77 Which expression represents $\frac{12x^3 - 6x^2 + 2x}{2x}$ in simplest form?

- 1) $6x^2 - 3x$
- 2) $10x^2 - 4x$
- 3) $6x^2 - 3x + 1$
- 4) $10x^2 - 4x + 1$

- 78 When $a^3 - 4a$ is factored completely, the result is

- 1) $(a - 2)(a + 2)$
- 2) $a(a - 2)(a + 2)$
- 3) $a^2(a - 4)$
- 4) $a(a - 2)^2$

- 79 Perform the indicated operation: $-6(a - 7)$
 State the name of the property used.

- 80 Which relation is a function?

- 1) $\left\{ \left(\frac{3}{4}, 0 \right), (0, 1), \left(\frac{3}{4}, 2 \right) \right\}$
- 2) $\left\{ (-2, 2), \left(-\frac{1}{2}, 1 \right), (-2, 4) \right\}$
- 3) $\{(-1, 4), (0, 5), (0, 4)\}$
- 4) $\{(2, 1), (4, 3), (6, 5)\}$

- 81 Find the roots of the equation $x^2 = 30 - 13x$ algebraically.

82 What is the sum of $\frac{-x+7}{2x+4}$ and $\frac{2x+5}{2x+4}$?

- 1) $\frac{x+12}{2x+4}$
- 2) $\frac{3x+12}{2x+4}$
- 3) $\frac{x+12}{4x+8}$
- 4) $\frac{3x+12}{4x+8}$

83 Which equation shows a correct trigonometric ratio for angle A in the right triangle below?

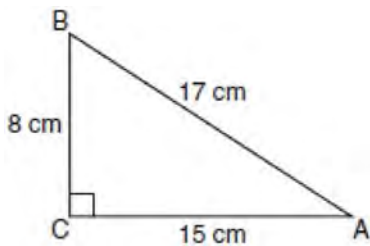

- 1) $\sin A = \frac{15}{17}$
- 2) $\tan A = \frac{8}{17}$
- 3) $\cos A = \frac{15}{17}$
- 4) $\tan A = \frac{5}{8}$

84 Which set-builder notation describes $\{-3, -2, -1, 0, 1, 2\}$?

- 1) $\{x | -3 \leq x < 2, \text{ where } x \text{ is an integer}\}$
- 2) $\{x | -3 < x \leq 2, \text{ where } x \text{ is an integer}\}$
- 3) $\{x | -3 < x < 2, \text{ where } x \text{ is an integer}\}$
- 4) $\{x | -3 \leq x \leq 2, \text{ where } x \text{ is an integer}\}$

85 Which table does *not* show bivariate data?

Height (inches)	Weight (pounds)
39	50
48	70
60	90

1)

Gallons	Miles Driven
15	300
20	400
25	500

2)

Quiz Average	Frequency
70	12
80	15
90	6

3)

Speed (mph)	Distance (miles)
40	80
50	120
55	150

4)

86 Given the following list of students' scores on a quiz:

5, 12, 7, 15, 20, 14, 7

Determine the median of these scores. Determine the mode of these scores. The teacher decides to adjust these scores by adding three points to each score. Explain the effect, if any, that this will have on the median and mode of these scores.

- 87 Graph and label the following equations on the set of axes below.

$$y = |x|$$

$$y = \left| \frac{1}{2}x \right|$$

Explain how *decreasing* the coefficient of x affects the graph of the equation $y = |x|$.

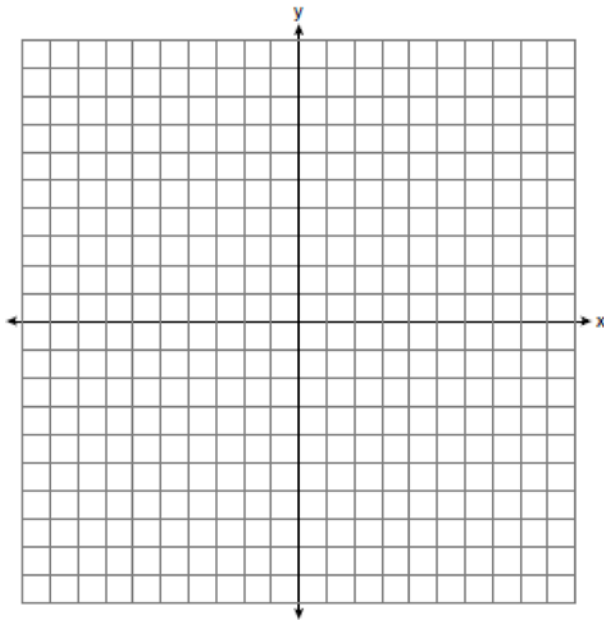

- 88 What is $3\sqrt{2} + \sqrt{8}$ expressed in simplest radical form?
- 1) $3\sqrt{10}$
 - 2) $3\sqrt{16}$
 - 3) $5\sqrt{2}$
 - 4) $7\sqrt{2}$

- 89 A study showed that a decrease in the cost of carrots led to an increase in the number of carrots sold. Which statement best describes this relationship?
- 1) positive correlation and a causal relationship
 - 2) negative correlation and a causal relationship
 - 3) positive correlation and not a causal relationship
 - 4) negative correlation and not a causal relationship

90 Express in simplest form: $\frac{45a^4b^3 - 90a^3b}{15a^2b}$

91 Which expression represents $\frac{x^2 - x - 6}{x^2 - 5x + 6}$ in simplest form?

- 1) $\frac{x+2}{x-2}$
- 2) $\frac{-x-6}{-5x+6}$
- 3) $\frac{1}{5}$
- 4) -1

- 92 Jon is buying tickets for himself for two concerts. For the jazz concert, 4 tickets are available in the front row, and 32 tickets are available in the other rows. For the orchestra concert, 3 tickets are available in the front row, and 23 tickets are available in the other rows. Jon is randomly assigned one ticket for each concert. Determine the concert for which he is more likely to get a front-row ticket. Justify your answer.

93 What is the solution set of $\frac{x+2}{x-2} = \frac{-3}{x}$?

- 1) $\{-2, 3\}$
- 2) $\{-3, -2\}$
- 3) $\{-1, 6\}$
- 4) $\{-6, 1\}$

94 In $\triangle ABC$, the measure of $\angle B = 90^\circ$, $AC = 50$, $AB = 48$, and $BC = 14$. Which ratio represents the tangent of $\angle A$?

- 1) $\frac{14}{50}$
- 2) $\frac{14}{48}$
- 3) $\frac{48}{50}$
- 4) $\frac{48}{14}$

95 Which expression is equivalent to $121 - x^2$?

- 1) $(x - 11)(x - 11)$
- 2) $(x + 11)(x - 11)$
- 3) $(11 - x)(11 + x)$
- 4) $(11 - x)(11 - x)$

96 How many different three-letter arrangements can be formed using the letters in the word *ABSOLUTE* if each letter is used only once?

- 1) 56
- 2) 112
- 3) 168
- 4) 336

97 Solve algebraically for x : $\frac{x+2}{6} = \frac{3}{x-1}$

98 An example of an algebraic expression is

- 1) $\frac{2x+3}{7} = \frac{13}{x}$
- 2) $(2x+1)(x-7)$
- 3) $4x - 1 = 4$
- 4) $x = 2$

99 What is the range of the data represented in the box-and-whisker plot shown below?

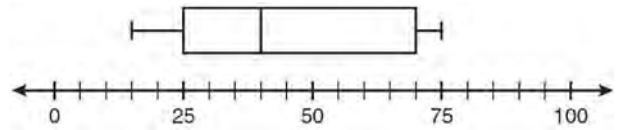

- 1) 40
- 2) 45
- 3) 60
- 4) 100

100 Solve for m : $\frac{m}{5} + \frac{3(m-1)}{2} = 2(m-3)$

101 The rectangle shown below has a diagonal of 18.4 cm and a width of 7 cm.

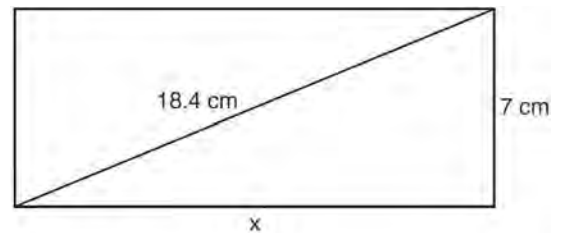

To the *nearest centimeter*, what is the length, x , of the rectangle?

- 1) 11
- 2) 17
- 3) 20
- 4) 25

- 102 The maximum height and speed of various roller coasters in North America are shown in the table below.

Maximum Speed, in mph, (x)	45	50	54	60	65	70
Maximum Height, in feet, (y)	63	80	105	118	141	107

Which graph represents a correct scatter plot of the data?

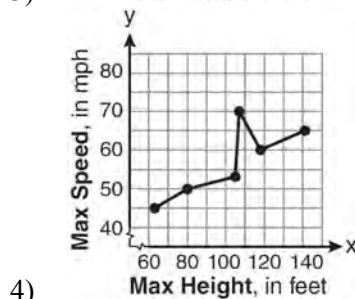
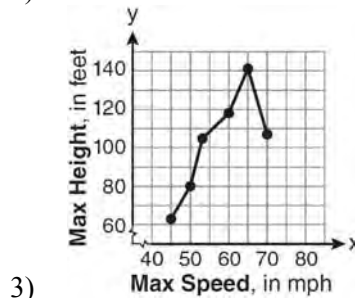
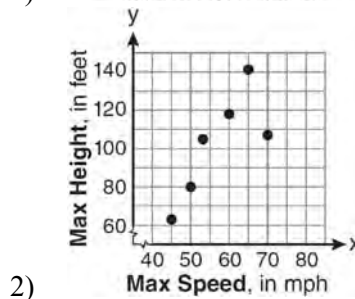
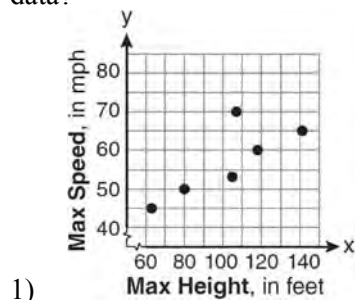

- 103 The ninth grade class at a local high school needs to purchase a park permit for \$250.00 for their upcoming class picnic. Each ninth grader attending the picnic pays \$0.75. Each guest pays \$1.25. If 200 ninth graders attend the picnic, which inequality can be used to determine the number of guests, x , needed to cover the cost of the permit?
- 1) $0.75x - (1.25)(200) \geq 250.00$
 - 2) $0.75x + (1.25)(200) \geq 250.00$
 - 3) $(0.75)(200) - 1.25x \geq 250.00$
 - 4) $(0.75)(200) + 1.25x \geq 250.00$

- 104 Maria has a set of 10 index cards labeled with the digits 0 through 9. She puts them in a bag and selects one at random. The outcome that is most likely to occur is selecting
- 1) an odd number
 - 2) a prime number
 - 3) a number that is at most 5
 - 4) a number that is divisible by 3

- 105 In right triangle ABC , $AB = 20$, $AC = 12$, $BC = 16$, and $m\angle C = 90$. Find, to the nearest degree, the measure of $\angle A$.

- 106 The expression $\frac{(10w^3)^2}{5w}$ is equivalent to
- 1) $2w^5$
 - 2) $2w^8$
 - 3) $20w^5$
 - 4) $20w^8$

- 107 Michael is 25 years younger than his father. The sum of their ages is 53. What is Michael's age?
- 1) 14
 - 2) 25
 - 3) 28
 - 4) 39

- 108 In the diagram below, $MATH$ is a rectangle, $GB = 4.6$, $MH = 6$, and $HT = 15$.

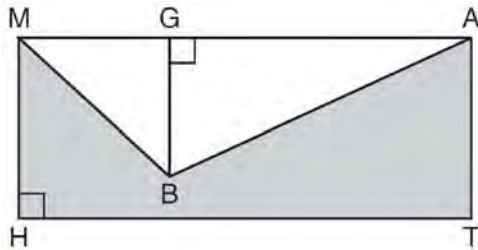

What is the area of polygon $MBATH$?

- 1) 34.5
 - 2) 55.5
 - 3) 90.0
 - 4) 124.5
- 109 Which equation represents the line that passes through the points $(-3, 7)$ and $(3, 3)$?
- 1) $y = \frac{2}{3}x + 1$
 - 2) $y = \frac{2}{3}x + 9$
 - 3) $y = -\frac{2}{3}x + 5$
 - 4) $y = -\frac{2}{3}x + 9$

- 110 Which graph represents an exponential equation?

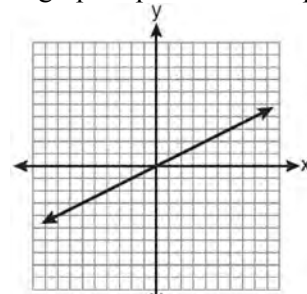

1)

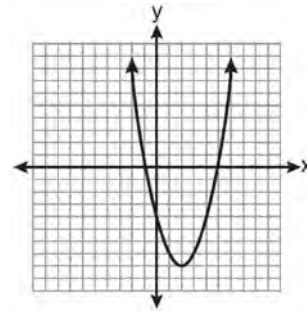

2)

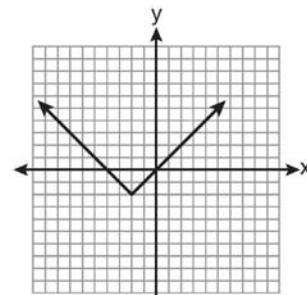

3)

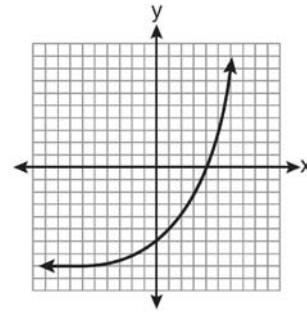

4)

111 What is the value of the expression $-3x^2y + 4x$ when $x = -4$ and $y = 2$?

- 1) -112
- 2) -80
- 3) 80
- 4) 272

112 Given: $X = \{1, 2, 3, 4\}$

$$Y = \{2, 3, 4, 5\}$$

$$Z = \{3, 4, 5, 6\}$$

What is the intersection of sets X , Y , and Z ?

- 1) $\{3, 4\}$
- 2) $\{2, 3, 4\}$
- 3) $\{3, 4, 5\}$
- 4) $\{1, 2, 3, 4, 5, 6\}$

113 In the diagram below, what is the slope of the line passing through points A and B ?

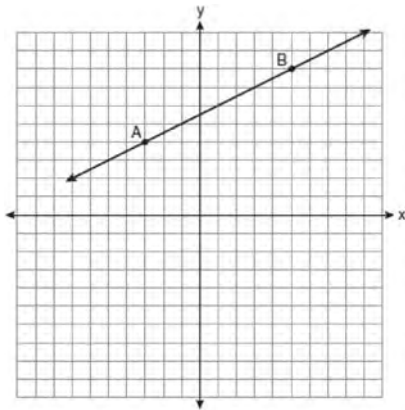

- 1) -2
- 2) 2
- 3) $-\frac{1}{2}$
- 4) $\frac{1}{2}$

114 Josh and Mae work at a concession stand. They each earn \$8 per hour. Josh worked three hours more than Mae. If Josh and Mae earned a total of \$120, how many hours did Josh work?

- 1) 6
- 2) 9
- 3) 12
- 4) 15

115 Which situation describes a correlation that is *not* a causal relationship?

- 1) the length of the edge of a cube and the volume of the cube
- 2) the distance traveled and the time spent driving
- 3) the age of a child and the number of siblings the child has
- 4) the number of classes taught in a school and the number of teachers employed

116 Which phrase best describes the relationship between the number of miles driven and the amount of gasoline used?

- 1) causal, but not correlated
- 2) correlated, but not causal
- 3) both correlated and causal
- 4) neither correlated nor causal

117 Which equation has roots of -3 and 5 ?

- 1) $x^2 + 2x - 15 = 0$
- 2) $x^2 - 2x - 15 = 0$
- 3) $x^2 + 2x + 15 = 0$
- 4) $x^2 - 2x + 15 = 0$

118 Which is the graph of $y = |x| + 2$?

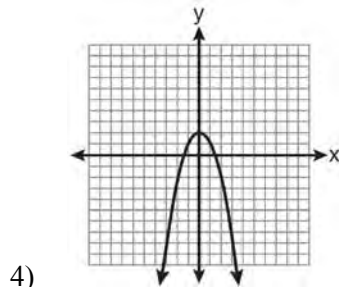
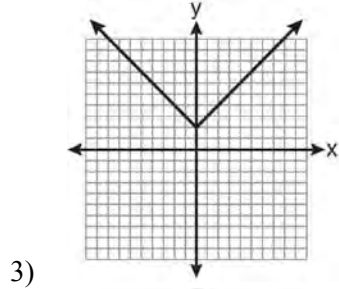
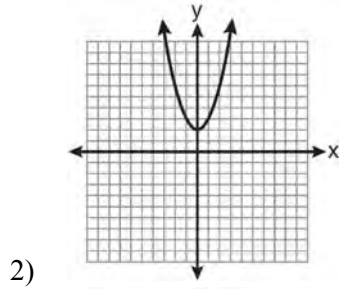
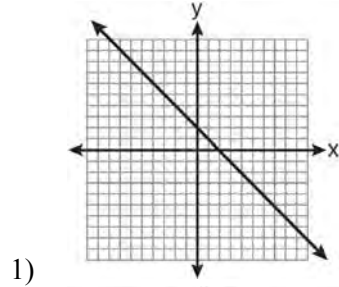

119 An example of an algebraic expression is

- 1) $x + 2$
- 2) $y = x + 2$
- 3) $y < x + 2$
- 4) $y = x^2 + 2x$

120 What is the value of x in the equation $2(x - 4) = 4(2x + 1)$?

- 1) -2
- 2) 2
- 3) $-\frac{1}{2}$
- 4) $\frac{1}{2}$

121 Three high school juniors, Reese, Matthew, and Chris, are running for student council president. A survey is taken a week before the election asking 40 students which candidate they will vote for in the election. The results are shown in the table below.

Candidate's Name	Number of Students Supporting Candidate
Reese	15
Matthew	13
Chris	12

Based on the table, what is the probability that a student will vote for Reese?

- 1) $\frac{1}{3}$
- 2) $\frac{3}{5}$
- 3) $\frac{3}{8}$
- 4) $\frac{5}{8}$

- 122 On the set of axes below, solve the following system of equations graphically for all values of x and y .

$$y = -x^2 - 4x + 12$$

$$y = -2x + 4$$

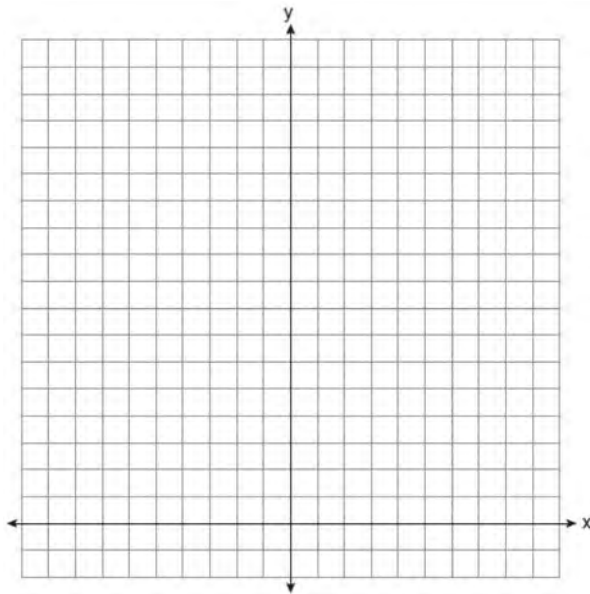

- 123 The expression $\sqrt{72} - 3\sqrt{2}$ written in simplest radical form is

- 1) $5\sqrt{2}$
- 2) $3\sqrt{6}$
- 3) $3\sqrt{2}$
- 4) $\sqrt{6}$

- 124 What is the perimeter of a regular pentagon with a side whose length is $x + 4$?

- 1) $x^2 + 16$
- 2) $4x + 16$
- 3) $5x + 4$
- 4) $5x + 20$

- 125 Which type of function is represented by the graph shown below?

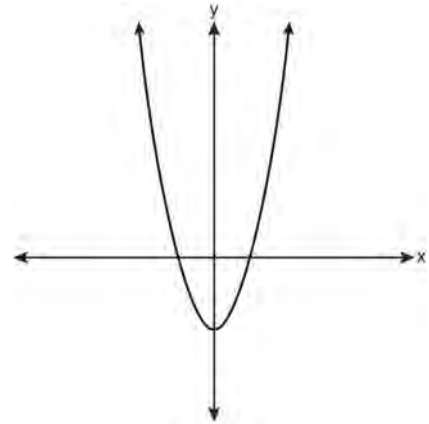

- 1) absolute value
- 2) exponential
- 3) linear
- 4) quadratic

- 126 The spinner shown in the diagram below is divided into six equal sections.

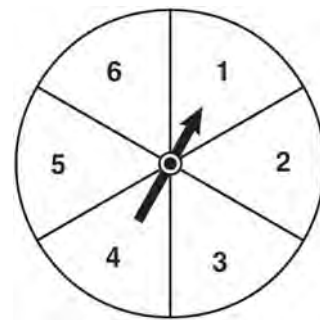

Which outcome is *least* likely to occur on a single spin?

- 1) an odd number
- 2) a prime number
- 3) a perfect square
- 4) a number divisible by 2

- 127 The freshman class held a canned food drive for 12 weeks. The results are summarized in the table below.

Canned Food Drive Results

Week	1	2	3	4	5	6	7	8	9	10	11	12
Number of Cans	20	35	32	45	58	46	28	23	31	79	65	62

Which number represents the second quartile of the number of cans of food collected?

- 1) 29.5
 - 2) 30.5
 - 3) 40
 - 4) 60
- 128 A hot-air balloon is tied to the ground with two taut (straight) ropes, as shown in the diagram below. One rope is directly under the balloon and makes a right angle with the ground. The other rope forms an angle of 50° with the ground.

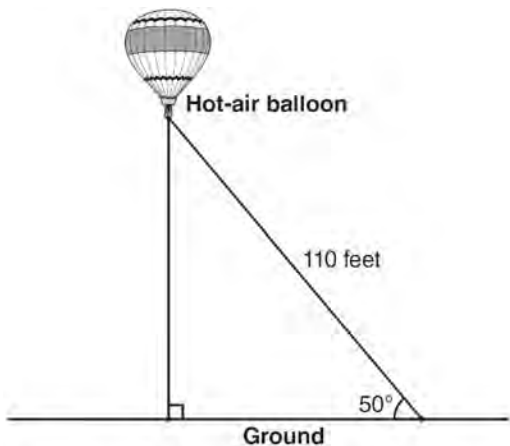

Determine the height, to the *nearest foot*, of the balloon directly above the ground. Determine the distance, to the *nearest foot*, on the ground between the two ropes.

- 129 Graph the following systems of inequalities on the set of axes shown below and label the solution set S :

$$y > -x + 2$$

$$y \leq \frac{2}{3}x + 5$$

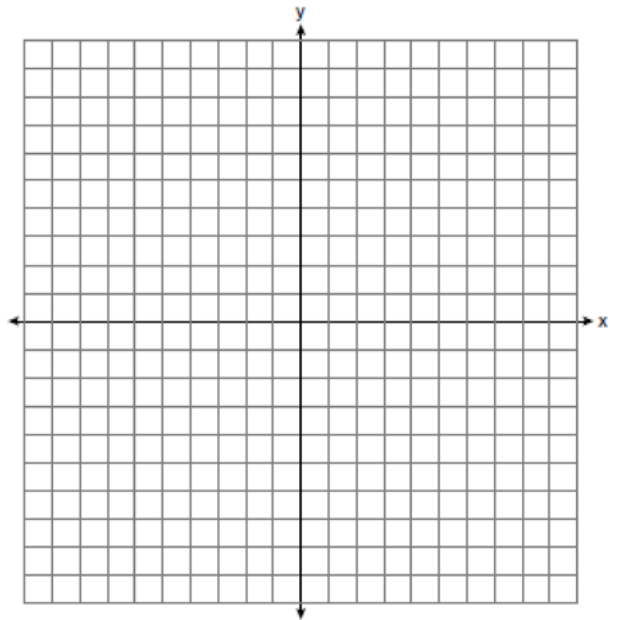

- 130 If the universal set is {pennies, nickels, dimes, quarters}, what is the complement of the set {nickels}?
- 1) { }
 - 2) {pennies, quarters}
 - 3) {pennies, dimes, quarters}
 - 4) {pennies, nickels, dimes, quarters}

Integrated Algebra Regents Exam Questions at Random

www.jmap.org

- 131 Which ordered pair is in the solution set of the following system of linear inequalities?

$$y < 2x + 2$$

$$y \geq -x - 1$$

- 1) (0,3)
- 2) (2,0)
- 3) (-1,0)
- 4) (-1,-4)

- 132 The height, y , of a ball tossed into the air can be represented by the equation $y = -x^2 + 10x + 3$, where x is the elapsed time. What is the equation of the axis of symmetry of this parabola?

- 1) $y = 5$
- 2) $y = -5$
- 3) $x = 5$
- 4) $x = -5$

- 133 Which set of data can be classified as qualitative?

- 1) scores of students in an algebra class
- 2) ages of students in a biology class
- 3) numbers of students in history classes
- 4) eye colors of students in an economics class

- 134 What is the solution of the system of equations

$$c + 3d = 8 \text{ and } c = 4d - 6?$$

- 1) $c = -14, d = -2$
- 2) $c = -2, d = 2$
- 3) $c = 2, d = 2$
- 4) $c = 14, d = -2$

- 135 Melissa graphed the equation $y = x^2$ and Dave graphed the equation $y = -3x^2$ on the same coordinate grid. What is the relationship between the graphs that Melissa and Dave drew?

- 1) Dave's graph is wider and opens in the opposite direction from Melissa's graph.
- 2) Dave's graph is narrower and opens in the opposite direction from Melissa's graph.
- 3) Dave's graph is wider and is three units below Melissa's graph.
- 4) Dave's graph is narrower and is three units to the left of Melissa's graph.

- 136 The width of a rectangle is 3 less than twice the length, x . If the area of the rectangle is 43 square feet, which equation can be used to find the length, in feet?

- 1) $2x(x - 3) = 43$
- 2) $x(3 - 2x) = 43$
- 3) $2x + 2(2x - 3) = 43$
- 4) $x(2x - 3) = 43$

- 137 What is the slope of the line whose equation is $3x - 7y = 9$?

- 1) $-\frac{3}{7}$
- 2) $\frac{3}{7}$
- 3) $-\frac{7}{3}$
- 4) $\frac{7}{3}$

- 138 Express $-3\sqrt{48}$ in simplest radical form.

139 A password consists of three digits, 0 through 9, followed by three letters from an alphabet having 26 letters. If repetition of digits is allowed, but repetition of letters is not allowed, determine the number of different passwords that can be made. If repetition is not allowed for digits or letters, determine how many fewer different passwords can be made.

140 Which ordered pair is in the solution set of the system of linear inequalities graphed below?

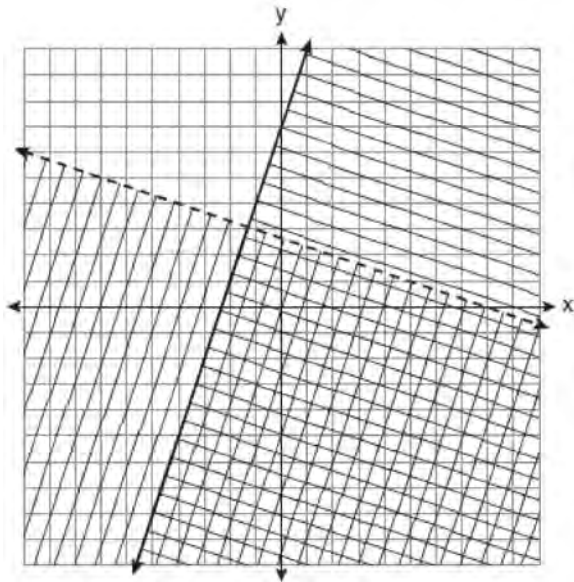

- 1) $(1, -4)$
- 2) $(-5, 7)$
- 3) $(5, 3)$
- 4) $(-7, -2)$

141 When 36 is subtracted from the square of a number, the result is five times the number. What is the positive solution?

- 1) 9
- 2) 6
- 3) 3
- 4) 4

142 What is the value of the y -coordinate of the solution to the system of equations $2x + y = 8$ and $x - 3y = -3$?

- 1) -2
- 2) 2
- 3) 3
- 4) -3

143 Which data set describes a situation that could be classified as quantitative?

- 1) the phone numbers in a telephone book
- 2) the addresses for students at Hopkins High School
- 3) the zip codes of residents in the city of Buffalo, New York
- 4) the time it takes each of Mr. Harper's students to complete a test

144 Which ordered pair is a solution to the system of equations $y = x + 3$ and $y = x^2 - x$?

- 1) $(6, 9)$
- 2) $(3, 6)$
- 3) $(3, -1)$
- 4) $(2, 5)$

145 Solve algebraically for x : $\frac{3}{4} = \frac{-(x+11)}{4x} + \frac{1}{2x}$

146 Given: Set $U = \{S, O, P, H, I, A\}$

Set $B = \{A, I, O\}$

If set B is a subset of set U , what is the complement of set B ?

- 1) $\{O, P, S\}$
- 2) $\{I, P, S\}$
- 3) $\{A, H, P\}$
- 4) $\{H, P, S\}$

147 What is the slope of the line passing through the points A and B , as shown on the graph below?

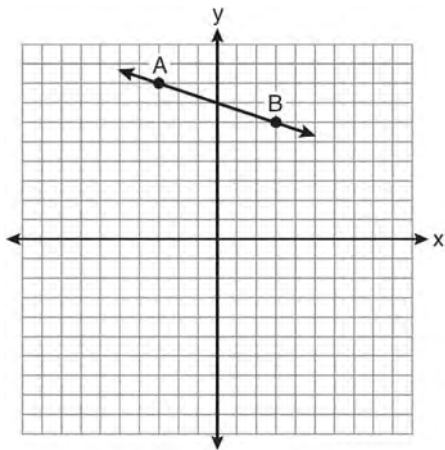

- 1) -3
- 2) $-\frac{1}{3}$
- 3) 3
- 4) $\frac{1}{3}$

148 What is the solution of the inequality

$$-6x - 17 \geq 8x + 25?$$

- 1) $x \geq 3$
- 2) $x \leq 3$
- 3) $x \geq -3$
- 4) $x \leq -3$

149 What is the solution of the system of equations
 $2x - 5y = 11$ and $-2x + 3y = -9$?

- 1) $(-3, -1)$
- 2) $(-1, 3)$
- 3) $(3, -1)$
- 4) $(3, 1)$

150 Which expression is equivalent to
 $-3x(x - 4) - 2x(x + 3)$?

- 1) $-x^2 - 1$
- 2) $-x^2 + 18x$
- 3) $-5x^2 - 6x$
- 4) $-5x^2 + 6x$

151 Which set of ordered pairs represents a function?

- 1) $\{(0, 4), (2, 4), (2, 5)\}$
- 2) $\{(6, 0), (5, 0), (4, 0)\}$
- 3) $\{(4, 1), (6, 2), (6, 3), (5, 0)\}$
- 4) $\{(0, 4), (1, 4), (0, 5), (1, 5)\}$

152 Factored completely, the expression $3x^2 - 3x - 18$ is equivalent to

- 1) $3(x^2 - x - 6)$
- 2) $3(x - 3)(x + 2)$
- 3) $(3x - 9)(x + 2)$
- 4) $(3x + 6)(x - 3)$

153 Which equation represents a quadratic function?

- 1) $y = x + 2$
- 2) $y = |x + 2|$
- 3) $y = x^2$
- 4) $y = 2^x$

- 154 A bag contains eight green marbles, five white marbles, and two red marbles. What is the probability of drawing a red marble from the bag?

- 1) $\frac{1}{15}$
- 2) $\frac{2}{15}$
- 3) $\frac{2}{13}$
- 4) $\frac{13}{15}$

- 155 An oil company distributes oil in a metal can shaped like a cylinder that has an actual radius of 5.1 cm and a height of 15.1 cm. A worker incorrectly measured the radius as 5 cm and the height as 15 cm. Determine the relative error in calculating the surface area, to the *nearest thousandth*.

- 156 Which value of x is the solution of the equation

$$\frac{2}{3}x + \frac{1}{2} = \frac{5}{6}?$$

- 1) $\frac{1}{2}$
- 2) 2
- 3) $\frac{2}{3}$
- 4) $\frac{3}{2}$

- 157 A cylinder has a diameter of 10 inches and a height of 2.3 inches. What is the volume of this cylinder, to the *nearest tenth of a cubic inch*?

- 1) 72.3
- 2) 83.1
- 3) 180.6
- 4) 722.6

- 158 Find three consecutive positive even integers such that the product of the second and third integers is twenty more than ten times the first integer. [Only an algebraic solution can receive full credit.]

- 159 Given: $U = \{1, 2, 3, 4, 5, 6, 7, 8\}$

$$B = \{2, 3, 5, 6\}$$

Set B is a subset of set U . What is the complement of set B ?

- 1) $\{\}$
- 2) $\{2, 3, 5, 6\}$
- 3) $\{1, 4, 7, 8\}$
- 4) $\{1, 2, 3, 4, 5, 6, 7, 8\}$

- 160 A garden is in the shape of an isosceles trapezoid and a semicircle, as shown in the diagram below. A fence will be put around the perimeter of the entire garden.

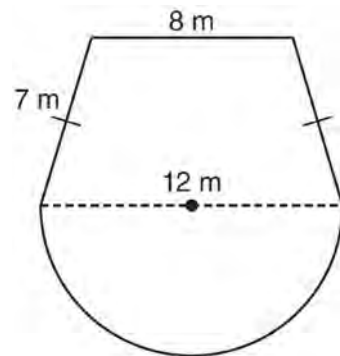

Which expression represents the length of fencing, in meters, that will be needed?

- 1) $22 + 6\pi$
- 2) $22 + 12\pi$
- 3) $15 + 6\pi$
- 4) $15 + 12\pi$

- 161 What are the vertex and axis of symmetry of the parabola shown in the diagram below?

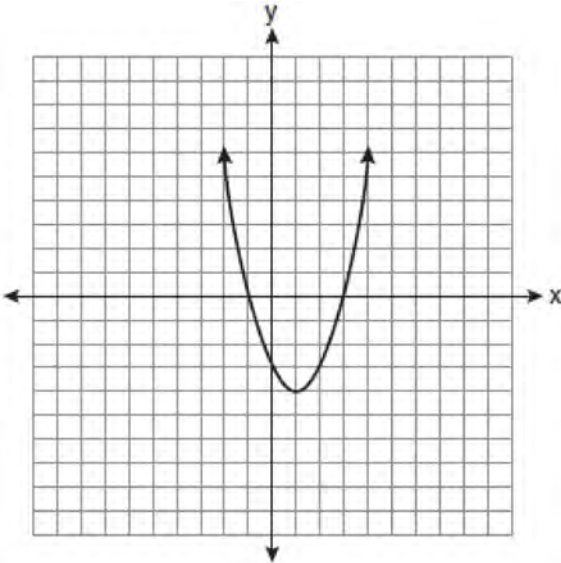

- 1) vertex: $(1, -4)$; axis of symmetry: $x = 1$
 - 2) vertex: $(1, -4)$; axis of symmetry: $x = -4$
 - 3) vertex: $(-4, 1)$; axis of symmetry: $x = 1$
 - 4) vertex: $(-4, 1)$; axis of symmetry: $x = -4$
- 162 A figure is made up of a rectangle and a semicircle as shown in the diagram below.

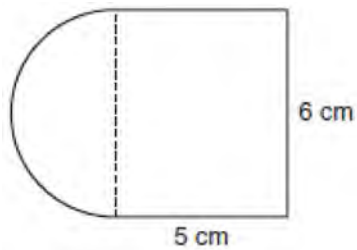

What is the area of the figure, to the *nearest tenth of a square centimeter*?

- 1) 39.4
- 2) 44.1
- 3) 48.8
- 4) 58.3

- 163 The sum of $4x^3 + 6x^2 + 2x - 3$ and $3x^3 + 3x^2 - 5x - 5$ is
- 1) $7x^3 + 3x^2 - 3x - 8$
 - 2) $7x^3 + 3x^2 + 7x + 2$
 - 3) $7x^3 + 9x^2 - 3x - 8$
 - 4) $7x^6 + 9x^4 - 3x^2 - 8$

- 164 In a recent town election, 1,860 people voted for either candidate *A* or candidate *B* for the position of supervisor. If candidate *A* received 55% of the votes, how many votes did candidate *B* receive?
- 1) 186
 - 2) 837
 - 3) 1,023
 - 4) 1,805

- 165 For which set of values of x is the algebraic expression $\frac{x^2 - 16}{x^2 - 4x - 12}$ undefined?
- 1) $\{-6, 2\}$
 - 2) $\{-4, 3\}$
 - 3) $\{-4, 4\}$
 - 4) $\{-2, 6\}$

- 166 Which relation represents a function?
- 1) $\{(0, 3), (2, 4), (0, 6)\}$
 - 2) $\{(-7, 5), (-7, 1), (-10, 3), (-4, 3)\}$
 - 3) $\{(2, 0), (6, 2), (6, -2)\}$
 - 4) $\{(-6, 5), (-3, 2), (1, 2), (6, 5)\}$

167 What is $\frac{7}{12x} - \frac{y}{6x^2}$ expressed in simplest form?

- 1) $\frac{7-y}{6x}$
- 2) $\frac{7-y}{12x-6x^2}$
- 3) $-\frac{7y}{12x^2}$
- 4) $\frac{7x-2y}{12x^2}$

168 Which interval notation represents the set of all real numbers greater than 2 and less than or equal to 20?

- 1) (2, 20)
- 2) (2, 20]
- 3) [2, 20)
- 4) [2, 20]

169 The Booster Club raised \$30,000 for a sports fund. No more money will be placed into the fund. Each year the fund will decrease by 5%. Determine the amount of money, to the *nearest cent*, that will be left in the sports fund after 4 years.

170 This year, John played in 10 baseball games. In these games he had hit the ball 2, 3, 0, 1, 3, 2, 4, 0, 2, and 3 times. In the first 10 games he plays next year, John wants to increase his average (mean) hits per game by 0.5. What is the total number of hits John needs over the first 10 games next year to achieve his goal?

- 1) 5
- 2) 2
- 3) 20
- 4) 25

171 If Ann correctly factors an expression that is the difference of two perfect squares, her factors could be

- 1) $(2x+y)(x-2y)$
- 2) $(2x+3y)(2x-3y)$
- 3) $(x-4)(x-4)$
- 4) $(2y-5)(y-5)$

172 Which point is on the line $4y - 2x = 0$?

- 1) (-2, -1)
- 2) (-2, 1)
- 3) (-1, -2)
- 4) (1, 2)

173 The number of calories burned while jogging varies directly with the number of minutes spent jogging. If George burns 150 calories by jogging for 20 minutes, how many calories does he burn by jogging for 30 minutes?

- 1) 100
- 2) 180
- 3) 200
- 4) 225

174 The value, y , of a \$15,000 investment over x years

is represented by the equation $y = 15000(1.2)^{\frac{x}{3}}$.

What is the profit (interest) on a 6-year investment?

- 1) \$6,600
- 2) \$10,799
- 3) \$21,600
- 4) \$25,799

175 The diagram below shows the graph of $y = -x^2 - c$.

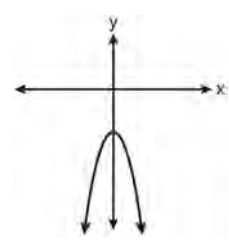

Which diagram shows the graph of $y = x^2 - c$?

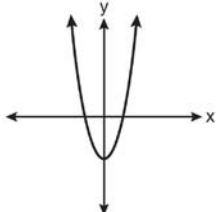
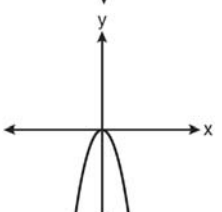
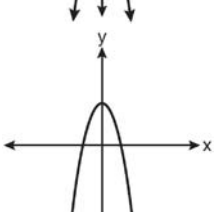
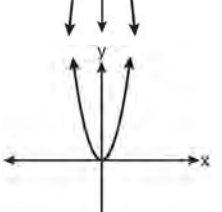
- 1) 
- 2) 
- 3) 
- 4) 

176 Corinne calculated the area of a paper plate to be 50.27 square inches. If the actual area of the plate is 55.42 square inches, what is the relative error in calculating the area, to the nearest thousandth?

- 1) 0.092
- 2) 0.093
- 3) 0.102
- 4) 0.103

177 What is the equation of the axis of symmetry of the parabola shown in the diagram below?

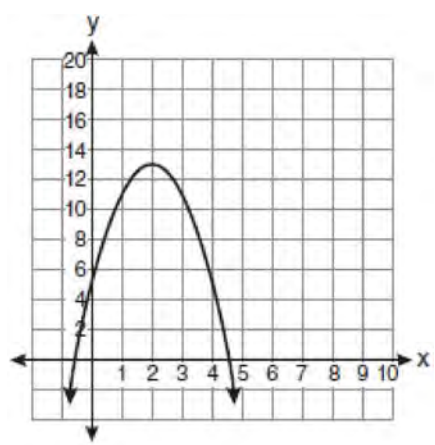

- 1) $x = -0.5$
- 2) $x = 2$
- 3) $x = 4.5$
- 4) $x = 13$

178 Which quadrant will be completely shaded in the graph of the inequality $y \leq 2x$?

- 1) Quadrant I
- 2) Quadrant II
- 3) Quadrant III
- 4) Quadrant IV

- 179 Which ordered pair is in the solution set of the system of inequalities shown in the graph below?

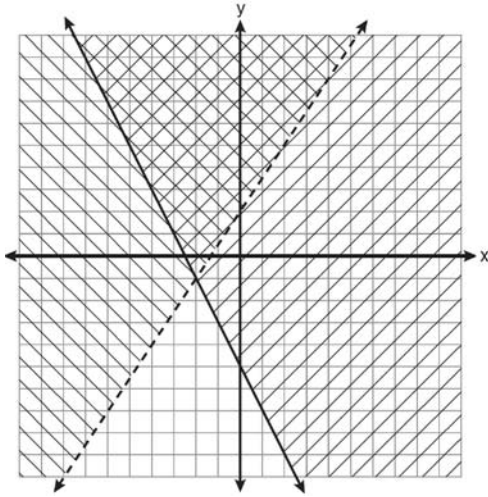

- 1) $(-2, -1)$
- 2) $(-2, 2)$
- 3) $(-2, -4)$
- 4) $(2, -2)$

- 180 A formula used for calculating velocity is $v = \frac{1}{2}at^2$. What is a expressed in terms of v and t ?

- 1) $a = \frac{2v}{t}$
- 2) $a = \frac{2v}{t^2}$
- 3) $a = \frac{v}{t}$
- 4) $a = \frac{v}{2t^2}$

- 181 Ben has four more than twice as many CDs as Jake. If they have a total of 31 CDs, how many CDs does Jake have?

- 1) 9
- 2) 13
- 3) 14
- 4) 22

- 182 An 8-foot rope is tied from the top of a pole to a stake in the ground, as shown in the diagram below.

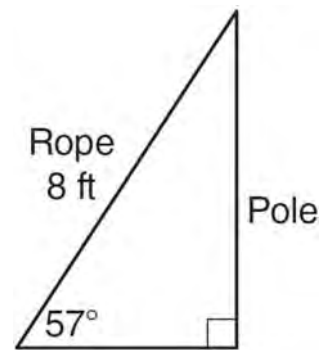

If the rope forms a 57° angle with the ground, what is the height of the pole, to the *nearest tenth of a foot*?

- 1) 4.4
- 2) 6.7
- 3) 9.5
- 4) 12.3

- 183 What is an equation of the line that passes through the points $(1, 3)$ and $(8, 5)$?

- 1) $y + 1 = \frac{2}{7}(x + 3)$
- 2) $y - 5 = \frac{2}{7}(x - 8)$
- 3) $y - 1 = \frac{2}{7}(x + 3)$
- 4) $y + 5 = \frac{2}{7}(x - 8)$

184 Which value of x is the solution of $\frac{x}{3} + \frac{x+1}{2} = x$?

- 1) 1
- 2) -1
- 3) 3
- 4) -3

185 A line having a slope of $\frac{3}{4}$ passes through the point $(-8, 4)$. Write the equation of this line in slope-intercept form.

186 Each of the hats shown below has colored marbles placed inside. Hat A contains five green marbles and four red marbles. Hat B contains six blue marbles and five red marbles. Hat C contains five green marbles and five blue marbles.



If a student were to randomly pick one marble from each of these three hats, determine from which hat the student would most likely pick a green marble. Justify your answer. Determine the fewest number of marbles, if any, and the color of these marbles that could be added to *each* hat so that the probability of picking a green marble will be one-half in each of the three hats.

187 If $\frac{ey}{n} + k = t$, what is y in terms of e , n , k , and t ?

- 1) $y = \frac{tn+k}{e}$
- 2) $y = \frac{tn-k}{e}$
- 3) $y = \frac{n(t+k)}{e}$
- 4) $y = \frac{n(t-k)}{e}$

188 Which ratio represents $\sin x$ in the right triangle shown below?

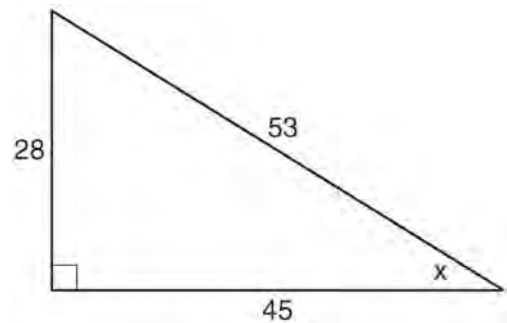

- 1) $\frac{28}{53}$
- 2) $\frac{28}{45}$
- 3) $\frac{45}{53}$
- 4) $\frac{53}{28}$

- 189 Solve the following system of inequalities graphically on the set of axes below.

$$3x + y < 7$$

$$y \geq \frac{2}{3}x - 4$$

State the coordinates of a point in the solution set.

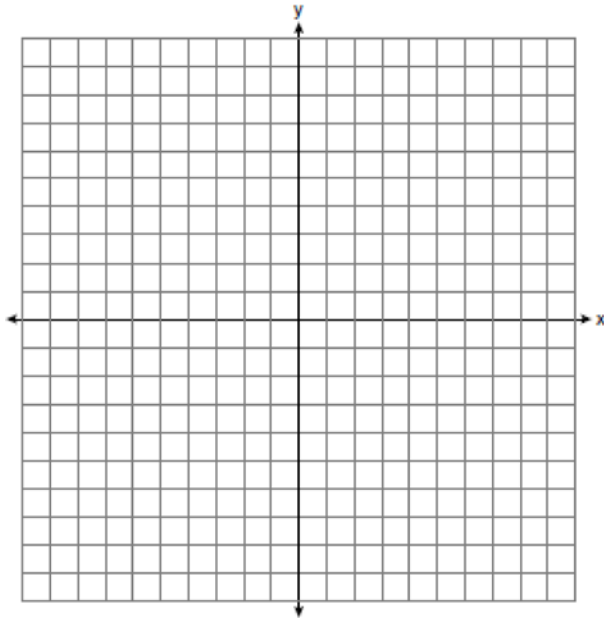

- 190 Vince buys a box of candy that consists of six chocolate pieces, four fruit-flavored pieces, and two mint pieces. He selects three pieces of candy at random, without replacement. Calculate the probability that the first piece selected will be fruit flavored and the other two will be mint. Calculate the probability that all three pieces selected will be the same type of candy.

- 191 Solve for c in terms of a and b : $bc + ac = ab$

- 192 The expression $6\sqrt{50} + 6\sqrt{2}$ written in simplest radical form is

- 1) $6\sqrt{52}$
- 2) $12\sqrt{52}$
- 3) $17\sqrt{2}$
- 4) $36\sqrt{2}$

- 193 The probability that it will snow on Sunday is $\frac{3}{5}$. The probability that it will snow on both Sunday and Monday is $\frac{3}{10}$. What is the probability that it will snow on Monday, if it snowed on Sunday?

- 1) $\frac{9}{50}$
- 2) 2
- 3) $\frac{1}{2}$
- 4) $\frac{9}{10}$

- 194 Based on the box-and-whisker plot below, which statement is *false*?

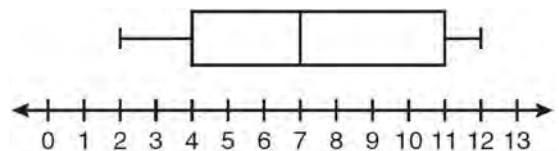

- 1) The median is 7.
- 2) The range is 12.
- 3) The first quartile is 4.
- 4) The third quartile is 11.

195 Given: $Q = \{0, 2, 4, 6\}$

$W = \{0, 1, 2, 3\}$

$Z = \{1, 2, 3, 4\}$

What is the intersection of sets Q , W , and Z ?

- 1) $\{2\}$
- 2) $\{0, 2\}$
- 3) $\{1, 2, 3\}$
- 4) $\{0, 1, 2, 3, 4, 6\}$

196 The end of a dog's leash is attached to the top of a 5-foot-tall fence post, as shown in the diagram below. The dog is 7 feet away from the base of the fence post.

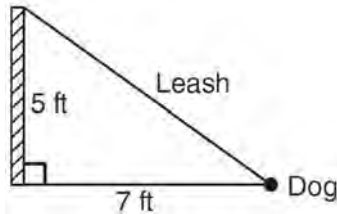

How long is the leash, to the *nearest tenth of a foot*?

- 1) 4.9
- 2) 8.6
- 3) 9.0
- 4) 12.0

197 The box-and-whisker plot below represents the math test scores of 20 students.

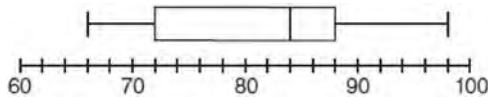

What percentage of the test scores are *less than 72*?

- 1) 25
- 2) 50
- 3) 75
- 4) 100

198 Which expression represents $\frac{-14a^2c^8}{7a^3c^2}$ in simplest form?

- 1) $-2ac^4$
- 2) $-2ac^6$
- 3) $\frac{-2c^4}{a}$
- 4) $\frac{-2c^6}{a}$

199 The dimensions of a rectangle are measured to be 12.2 inches by 11.8 inches. The actual dimensions are 12.3 inches by 11.9 inches. What is the relative error, to the *nearest ten-thousandth*, in calculating the area of the rectangle?

- 1) 0.0168
- 2) 0.0167
- 3) 0.0165
- 4) 0.0164

200 State the equation of the axis of symmetry and the coordinates of the vertex of the parabola graphed below.

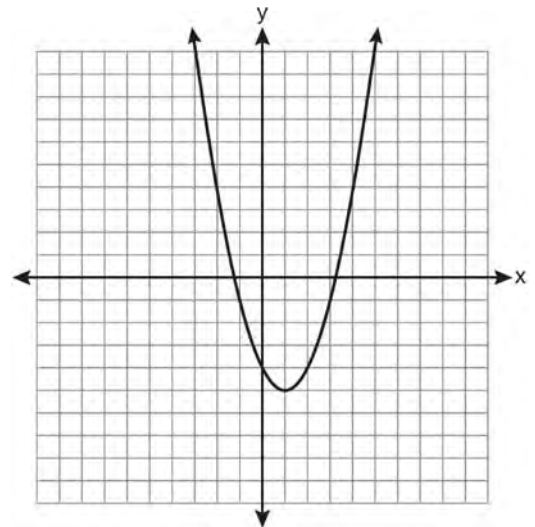

- 201 Which graph could be used to find the solution of the system of equations $y = 2x + 6$ and $y = x^2 + 4x + 3$?

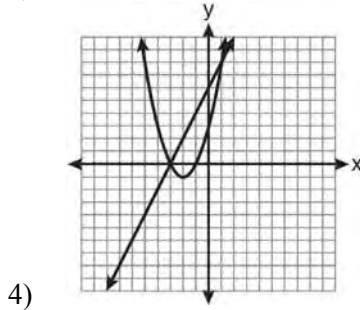
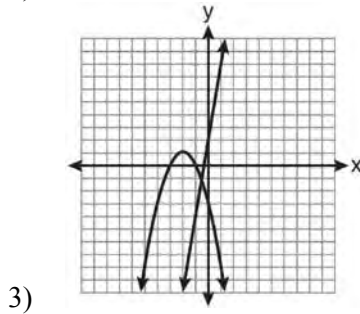
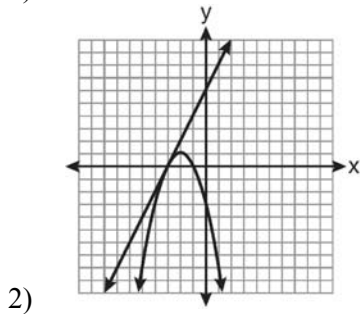
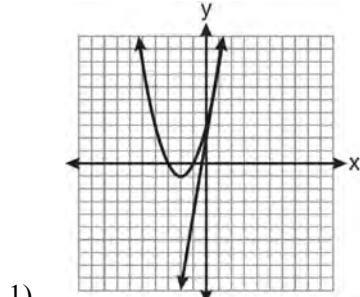

- 202 The area of a rectangle is represented by $x^2 - 5x - 24$. If the width of the rectangle is represented by $x - 8$, express the length of the rectangle as a binomial.

- 203 What is the slope of the line passing through the points $(-2, 4)$ and $(3, 6)$?

- 1) $-\frac{5}{2}$
- 2) $-\frac{2}{5}$
- 3) $\frac{2}{5}$
- 4) $\frac{5}{2}$

- 204 Which point lies on the line whose equation is $2x - 3y = 9$?

- 1) $(-1, -3)$
- 2) $(-1, 3)$
- 3) $(0, 3)$
- 4) $(0, -3)$

- 205 What is the product of (6×10^3) , (4.6×10^5) , and (2×10^{-2}) expressed in scientific notation?

- 1) 55.2×10^6
- 2) 5.52×10^7
- 3) 55.2×10^7
- 4) 5.52×10^{10}

206 A method for solving $5(x - 2) - 2(x - 5) = 9$ is shown below. Identify the property used to obtain each of the two indicated steps.

$$5(x - 2) - 2(x - 5) = 9$$

(1) $5x - 10 - 2x + 10 = 9$ (1) _____

(2) $5x - 2x - 10 + 10 = 9$ (2) _____

$$3x + 0 = 9$$

$$3x = 9$$

$$x = 3$$

207 What is the relationship between the independent and dependent variables in the scatter plot shown below?

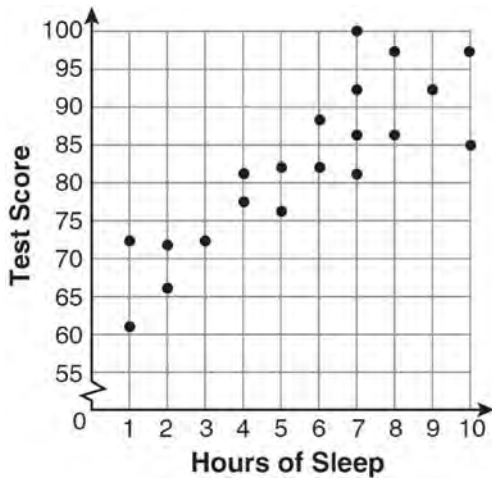

- 1) undefined correlation
- 2) negative correlation
- 3) positive correlation
- 4) no correlation

208 Which graph can be used to find the solution of the following system of equations?

$$y = x^2 + 2x + 3$$

$$2y - 2x = 10$$

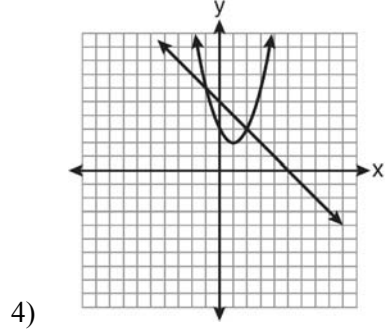
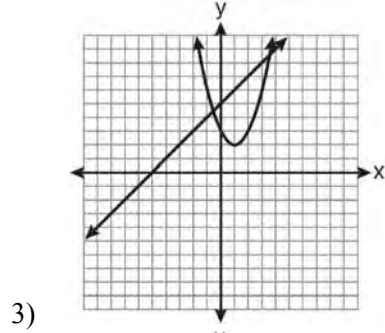
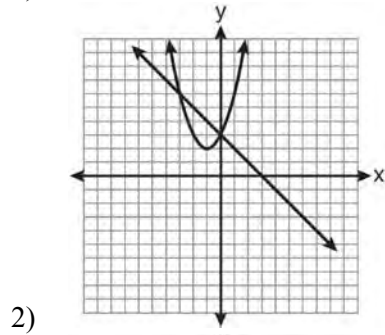
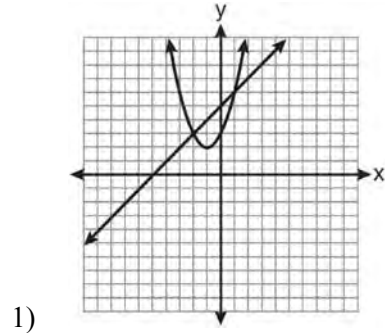

- 209 Graph the solution set for the inequality $4x - 3y > 9$ on the set of axes below. Determine if the point $(1, -3)$ is in the solution set. Justify your answer.

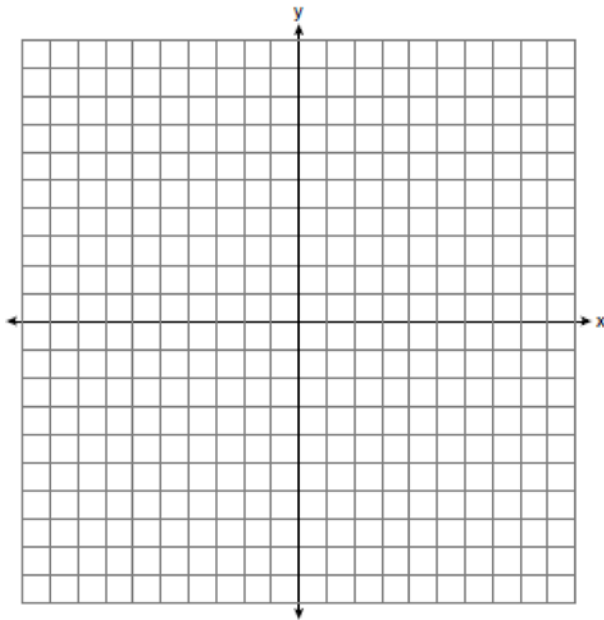

- 210 What is the slope of the line that passes through the points $(3, 5)$ and $(-2, 2)$?

- 1) $\frac{1}{5}$
- 2) $\frac{3}{5}$
- 3) $\frac{5}{3}$
- 4) 5

- 211 What is $3\sqrt{250}$ expressed in simplest radical form?

- 1) $5\sqrt{10}$
- 2) $8\sqrt{10}$
- 3) $15\sqrt{10}$
- 4) $75\sqrt{10}$

- 212 A communications company is building a 30-foot antenna to carry cell phone transmissions. As shown in the diagram below, a 50-foot wire from the top of the antenna to the ground is used to stabilize the antenna.

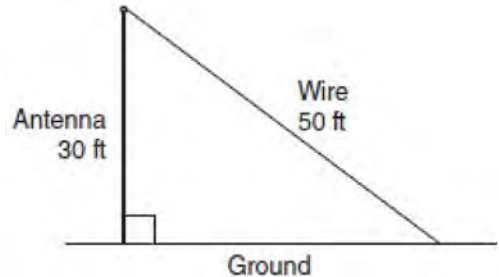

Find, to the *nearest degree*, the measure of the angle that the wire makes with the ground.

- 213 On the set of axes below, solve the following system of equations graphically and state the coordinates of *all* points in the solution set.

$$y = -x^2 + 6x - 3$$

$$x + y = 7$$

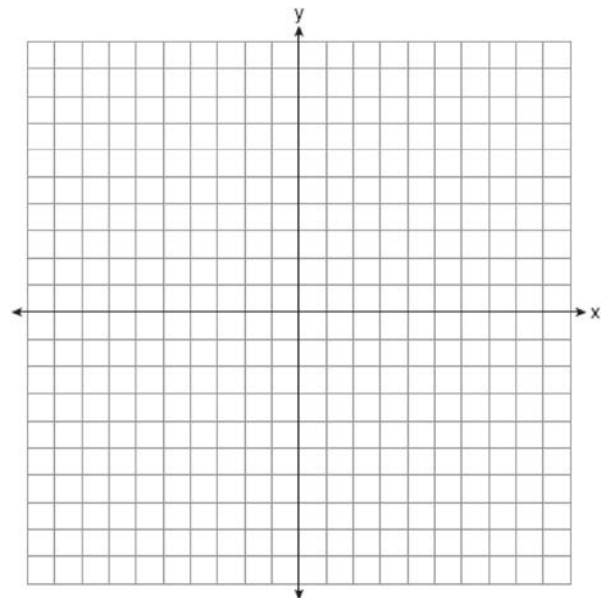

- 214 A spinner that is equally divided into eight numbered sectors is spun 20 times. The table below shows the number of times the arrow landed in each numbered sector.

Spinner Sector	Number of Times
1	2
2	3
3	2
4	3
5	4
6	2
7	3
8	1

Based on the table, what is the empirical probability that the spinner will land on a prime number on the next spin?

- 1) $\frac{9}{20}$
- 2) $\frac{11}{20}$
- 3) $\frac{12}{20}$
- 4) $\frac{14}{20}$

- 215 A trapezoid is shown below.

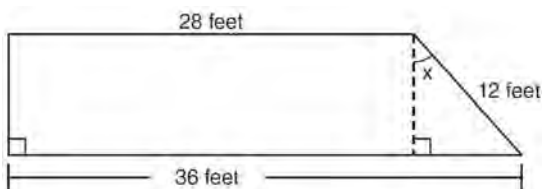

Calculate the measure of angle x , to the nearest tenth of a degree.

- 216 Which data table represents univariate data?

Side Length of a Square	Area of Square
2	4
3	9
4	16
5	25

1)

Hours Worked	Pay
20	\$160
25	\$200
30	\$240
35	\$280

2)

Age Group	Frequency
20–29	9
30–39	7
40–49	10
50–59	4

3)

People	Number of Fingers
2	20
3	30
4	40
5	50

4)

- 217 Roger is having a picnic for 78 guests. He plans to serve each guest at least one hot dog. If each package, p , contains eight hot dogs, which inequality could be used to determine how many packages of hot dogs Roger will need to buy?

- 1) $p \geq 78$
- 2) $8p \geq 78$
- 3) $8 + p \geq 78$
- 4) $78 - p \geq 8$

218 Which graph represents a function?

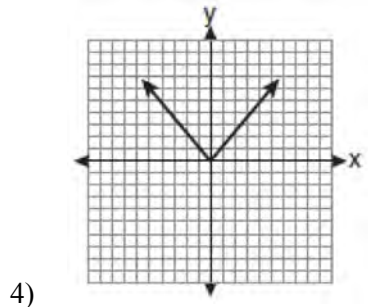
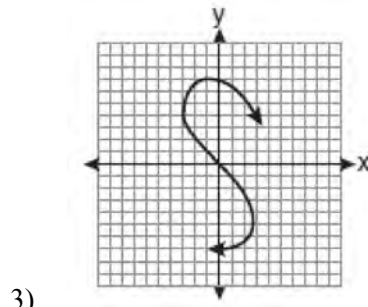
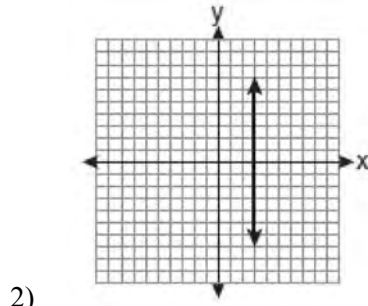
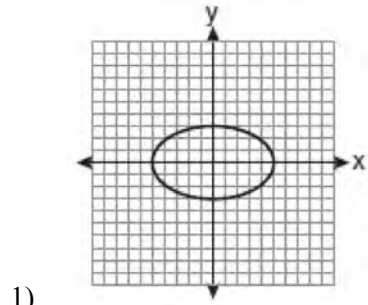

219 Which set represents the intersection of sets A, B, and C shown in the diagram below?

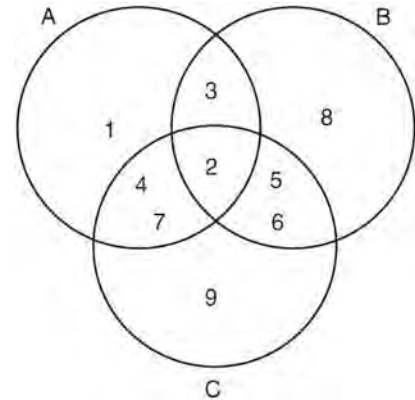

- 1) {3, 4, 5, 6, 7}
- 2) {2}
- 3) {2, 3, 4, 5, 6, 7}
- 4) {1, 2, 3, 4, 5, 6, 7, 8, 9}

220 Which equation represents the line that passes through the point (1, 5) and has a slope of -2 ?

- 1) $y = -2x + 7$
- 2) $y = -2x + 11$
- 3) $y = 2x - 9$
- 4) $y = 2x + 3$

221 What are the factors of the expression $x^2 + x - 20$?

- 1) $(x + 5)$ and $(x + 4)$
- 2) $(x + 5)$ and $(x - 4)$
- 3) $(x - 5)$ and $(x + 4)$
- 4) $(x - 5)$ and $(x - 4)$

222 The school store did a study comparing the cost of a sweatshirt with the number of sweatshirts sold. The price was changed several times and the numbers of sweatshirts sold were recorded. The data are shown in the table below.

Cost of Sweatshirt	\$10	\$25	\$15	\$20	\$5
Number Sold	9	6	15	11	14

Which scatter plot represents the data?

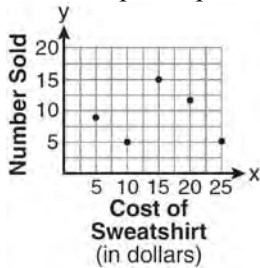

1)

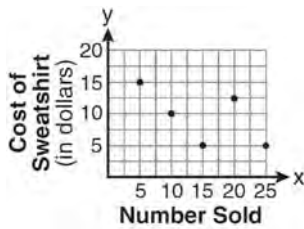

2)

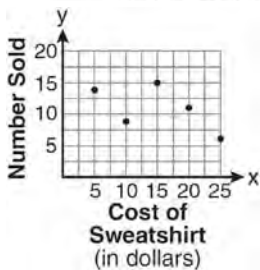

3)

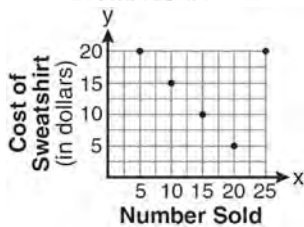

4)

223 Right triangle ABC has legs of 8 and 15 and a hypotenuse of 17, as shown in the diagram below.

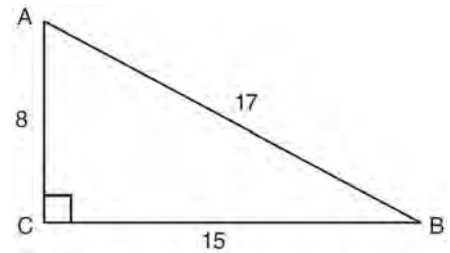

The value of the tangent of $\angle B$ is

- 1) 0.4706
- 2) 0.5333
- 3) 0.8824
- 4) 1.8750

224 What is the sum of $\frac{3x^2}{x-2}$ and $\frac{x^2}{x-2}$?

- 1) $\frac{3x^4}{(x-2)^2}$
- 2) $\frac{3x^4}{x-2}$
- 3) $\frac{4x^2}{(x-2)^2}$
- 4) $\frac{4x^2}{x-2}$

225 Find the volume, in cubic centimeters, and the surface area, in square centimeters, of the rectangular prism shown below.

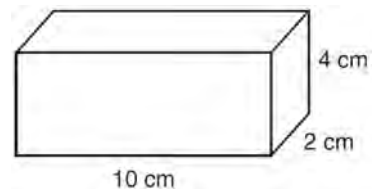

- 226 The square dart board shown below has a side that measures 40 inches. The shaded portion in the center is a square whose side is 15 inches. A dart thrown at the board is equally likely to land on any point on the dartboard.

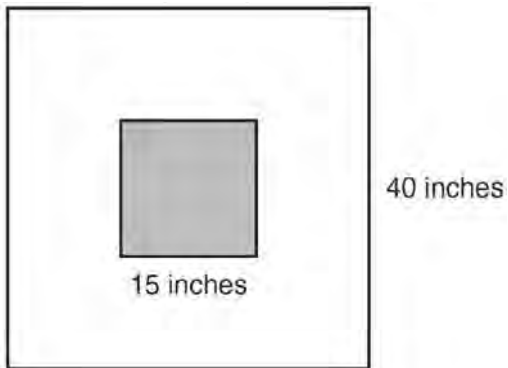

Find the probability that a dart hitting the board will *not* land in the shaded area.

- 227 Chelsea has \$45 to spend at the fair. She spends \$20 on admission and \$15 on snacks. She wants to play a game that costs \$0.65 per game. Write an inequality to find the maximum number of times, x , Chelsea can play the game. Using this inequality, determine the maximum number of times she can play the game.
- 228 Angela wants to purchase carpeting for her living room. The dimensions of her living room are 12 feet by 12 feet. If carpeting is sold by the square yard, determine how many square yards of carpeting she must purchase.

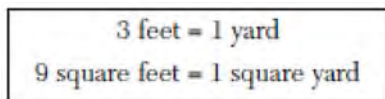

- 229 Which notation describes $\{1, 2, 3\}$?
- 1) $\{x | 1 \leq x < 3, \text{ where } x \text{ is an integer}\}$
 - 2) $\{x | 0 < x \leq 3, \text{ where } x \text{ is an integer}\}$
 - 3) $\{x | 1 < x < 3, \text{ where } x \text{ is an integer}\}$
 - 4) $\{x | 0 \leq x \leq 3, \text{ where } x \text{ is an integer}\}$
- 230 What is the quotient of $\frac{x}{x+4}$ divided by $\frac{2x}{x^2-16}$?
- 1) $\frac{2}{x-4}$
 - 2) $\frac{2x^2}{x-4}$
 - 3) $\frac{2x^2}{x^2-16}$
 - 4) $\frac{x-4}{2}$
- 231 Julia went to the movies and bought one jumbo popcorn and two chocolate chip cookies for \$5.00. Marvin went to the same movie and bought one jumbo popcorn and four chocolate chip cookies for \$6.00. How much does one chocolate chip cookie cost?
- 1) \$0.50
 - 2) \$0.75
 - 3) \$1.00
 - 4) \$2.00
- 232 The value of a car purchased for \$20,000 decreases at a rate of 12% per year. What will be the value of the car after 3 years?
- 1) \$12,800.00
 - 2) \$13,629.44
 - 3) \$17,600.00
 - 4) \$28,098.56

Integrated Algebra Regents at Random

- 233 Which value of x makes the expression $\frac{x^2 - 9}{x^2 + 7x + 10}$ undefined?
- 1) -5
 - 2) 2
 - 3) 3
 - 4) -3
- 234 The ages of three brothers are consecutive even integers. Three times the age of the youngest brother exceeds the oldest brother's age by 48 years. What is the age of the youngest brother?
- 1) 14
 - 2) 18
 - 3) 22
 - 4) 26
- 235 A rectangle has an area of 24 square units. The width is 5 units less than the length. What is the length, in units, of the rectangle?
- 1) 6
 - 2) 8
 - 3) 3
 - 4) 19
- 236 Which value of x is a solution of $\frac{5}{x} = \frac{x+13}{6}$?
- 1) -2
 - 2) -3
 - 3) -10
 - 4) -15
- 237 Which value of n makes the expression $\frac{5n}{2n-1}$ undefined?
- 1) 1
 - 2) 0
 - 3) $-\frac{1}{2}$
 - 4) $\frac{1}{2}$
- 238 Which equation represents a line parallel to the x -axis?
- 1) $y = -5$
 - 2) $y = -5x$
 - 3) $x = 3$
 - 4) $x = 3y$
- 239 Which ordered pair is in the solution set of the following system of inequalities?
- $$y < \frac{1}{2}x + 4$$
- $$y \geq -x + 1$$
- 1) $(-5, 3)$
 - 2) $(0, 4)$
 - 3) $(3, -5)$
 - 4) $(4, 0)$
- 240 When $5\sqrt{20}$ is written in simplest radical form, the result is $k\sqrt{5}$. What is the value of k ?
- 1) 20
 - 2) 10
 - 3) 7
 - 4) 4

241 At the end of week one, a stock had increased in value from \$5.75 a share to \$7.50 a share. Find the percent of increase at the end of week one to the nearest tenth of a percent. At the end of week two, the same stock had decreased in value from \$7.50 to \$5.75. Is the percent of decrease at the end of week two the same as the percent of increase at the end of week one? Justify your answer.

242 Factored completely, the expression $2x^2 + 10x - 12$ is equivalent to

- 1) $2(x - 6)(x + 1)$
- 2) $2(x + 6)(x - 1)$
- 3) $2(x + 2)(x + 3)$
- 4) $2(x - 2)(x - 3)$

243 The expression $x^2 - 16$ is equivalent to

- 1) $(x + 2)(x - 8)$
- 2) $(x - 2)(x + 8)$
- 3) $(x + 4)(x - 4)$
- 4) $(x + 8)(x - 8)$

244 Express the product of $3\sqrt{20}(2\sqrt{5} - 7)$ in simplest radical form.

245 The expression $9x^2 - 100$ is equivalent to

- 1) $(9x - 10)(x + 10)$
- 2) $(3x - 10)(3x + 10)$
- 3) $(3x - 100)(3x - 1)$
- 4) $(9x - 100)(x + 1)$

246 The table below shows a cumulative frequency distribution of runners' ages.

Cumulative Frequency Distribution of Runners' Ages

Age Group	Total
20-29	8
20-39	18
20-49	25
20-59	31
20-69	35

According to the table, how many runners are in their forties?

- 1) 25
- 2) 10
- 3) 7
- 4) 6

247 What is the slope of the line containing the points (3, 4) and (-6, 10)?

- 1) $\frac{1}{2}$
- 2) 2
- 3) $-\frac{2}{3}$
- 4) $-\frac{3}{2}$

248 What is an equation of the line that passes through the points (3, -3) and (-3, -3)?

- 1) $y = 3$
- 2) $x = -3$
- 3) $y = -3$
- 4) $x = y$

249 Factor completely: $4x^3 - 36x$

250 The gas tank in a car holds a total of 16 gallons of gas. The car travels 75 miles on 4 gallons of gas. If the gas tank is full at the beginning of a trip, which graph represents the rate of change in the amount of gas in the tank?

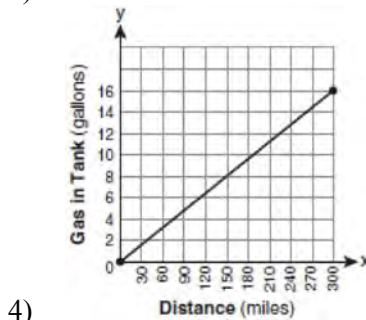
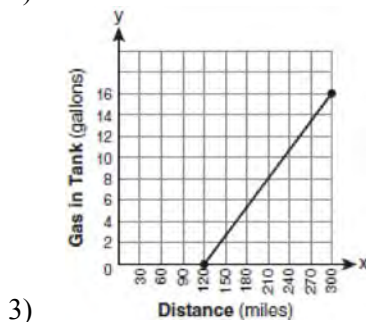
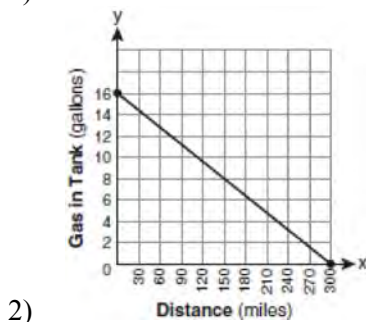
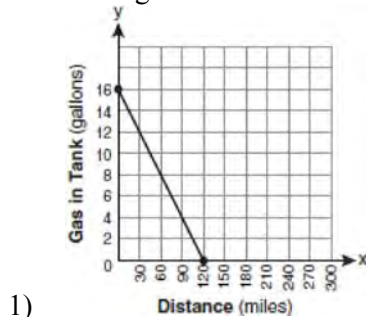

251 Chad complained to his friend that he had five equations to solve for homework. Are all of the homework problems equations? Justify your answer.

Math Homework

1. $3x^2 \cdot 2x^4$
2. $5 - 2x = 3x$
3. $3(2x + 7)$
4. $7x^2 + 2x - 3x^2 - 9$
5. $\frac{2}{3} = \frac{x+2}{6}$

Name Chad

252 What is $\sqrt{72}$ expressed in simplest radical form?

- 1) $2\sqrt{18}$
- 2) $3\sqrt{8}$
- 3) $6\sqrt{2}$
- 4) $8\sqrt{3}$

253 Which expression is equivalent to $9x^2 - 16$?

- 1) $(3x + 4)(3x - 4)$
- 2) $(3x - 4)(3x - 4)$
- 3) $(3x + 8)(3x - 8)$
- 4) $(3x - 8)(3x - 8)$

254 What is the product of 8.4×10^8 and 4.2×10^3 written in scientific notation?

- 1) 2.0×10^5
- 2) 12.6×10^{11}
- 3) 35.28×10^{11}
- 4) 3.528×10^{12}

255 What is the slope of the line that passes through the points $(-5, 4)$ and $(15, -4)$?

- 1) $-\frac{2}{5}$
- 2) 0
- 3) $-\frac{5}{2}$
- 4) undefined

256 The data set 5, 6, 7, 8, 9, 9, 9, 10, 12, 14, 17, 17, 18, 19, 19 represents the number of hours spent on the Internet in a week by students in a mathematics class. Which box-and-whisker plot represents the data?

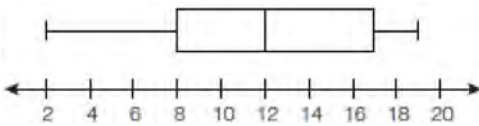
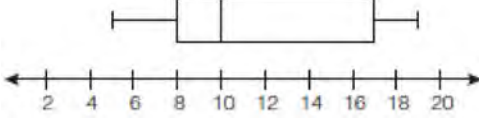
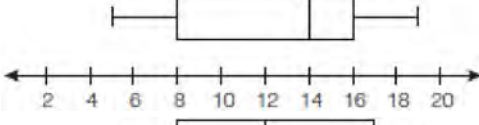
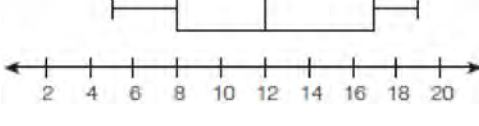
- 1) 
- 2) 
- 3) 
- 4) 

257 What are the roots of the equation $x^2 - 7x + 6 = 0$?

- 1) 1 and 7
- 2) -1 and 7
- 3) -1 and -6
- 4) 1 and 6

258 A designer created the logo shown below. The logo consists of a square and four quarter-circles of equal size.

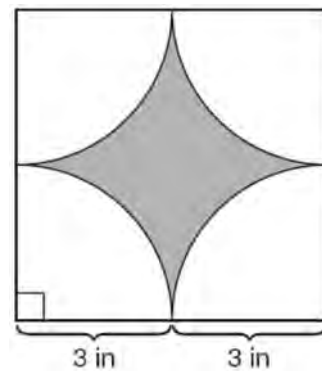

Express, in terms of π , the exact area, in square inches, of the shaded region.

259 To calculate the volume of a small wooden cube, Ezra measured an edge of the cube as 2 cm. The actual length of the edge of Ezra's cube is 2.1 cm. What is the relative error in his volume calculation to the *nearest hundredth*?

- 1) 0.13
- 2) 0.14
- 3) 0.15
- 4) 0.16

- 260 A stake is to be driven into the ground away from the base of a 50-foot pole, as shown in the diagram below. A wire from the stake on the ground to the top of the pole is to be installed at an angle of elevation of 52° .

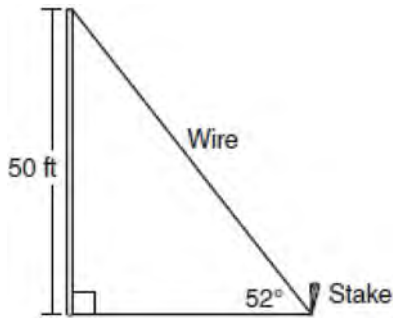

How far away from the base of the pole should the stake be driven in, to the *nearest foot*? What will be the length of the wire from the stake to the top of the pole, to the *nearest foot*?

- 261 Hannah took a trip to visit her cousin. She drove 120 miles to reach her cousin's house and the same distance back home. It took her 1.2 hours to get halfway to her cousin's house. What was her average speed, in miles per hour, for the first 1.2 hours of the trip? Hannah's average speed for the remainder of the trip to her cousin's house was 40 miles per hour. How long, in hours, did it take her to drive the remaining distance? Traveling home along the same route, Hannah drove at an average rate of 55 miles per hour. After 2 hours her car broke down. How many miles was she from home?

- 262 The sum of two numbers is 47, and their difference is 15. What is the larger number?
- 1) 16
 - 2) 31
 - 3) 32
 - 4) 36

- 263 Which graph represents a linear function?

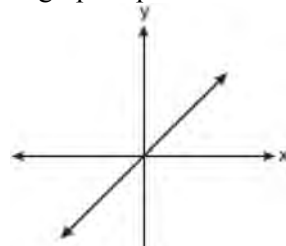

1)

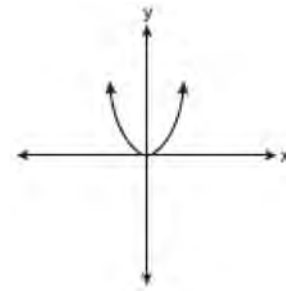

2)

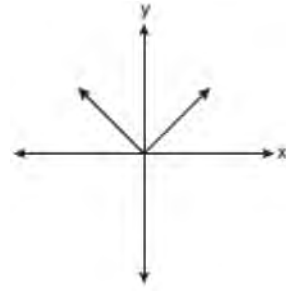

3)

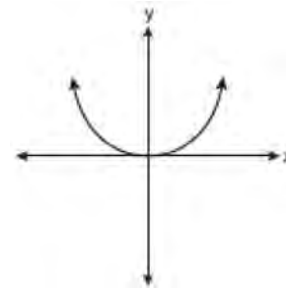

4)

- 264 Which property is illustrated by the equation $ax + ay = a(x + y)$?

- 1) associative
- 2) commutative
- 3) distributive
- 4) identity

- 265 Which expression represents $\frac{(2x^3)(8x^5)}{4x^6}$ in simplest form?
- 1) x^2
 - 2) x^9
 - 3) $4x^2$
 - 4) $4x^9$

- 266 A cylindrical container has a diameter of 12 inches and a height of 15 inches, as illustrated in the diagram below.

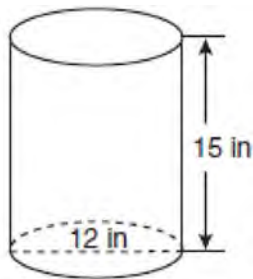

(Not drawn to scale)

What is the volume of this container to the *nearest tenth* of a cubic inch?

- 1) 6,785.8
 - 2) 4,241.2
 - 3) 2,160.0
 - 4) 1,696.5
- 267 Students in a ninth grade class measured their heights, h , in centimeters. The height of the shortest student was 155 cm, and the height of the tallest student was 190 cm. Which inequality represents the range of heights?
- 1) $155 < h < 190$
 - 2) $155 \leq h \leq 190$
 - 3) $h \geq 155$ or $h \leq 190$
 - 4) $h > 155$ or $h < 190$

- 268 The Fahrenheit temperature readings on 30 April mornings in Stormville, New York, are shown below.

41°, 58°, 61°, 54°, 49°, 46°, 52°, 58°, 67°, 43°,
 47°, 60°, 52°, 58°, 48°, 44°, 59°, 66°, 62°, 55°,
 44°, 49°, 62°, 61°, 59°, 54°, 57°, 58°, 63°, 60°

Using the data, complete the frequency table below.

Interval	Tally	Frequency
40–44		
45–49		
50–54		
55–59		
60–64		
65–69		

On the grid below, construct and label a frequency histogram based on the table.

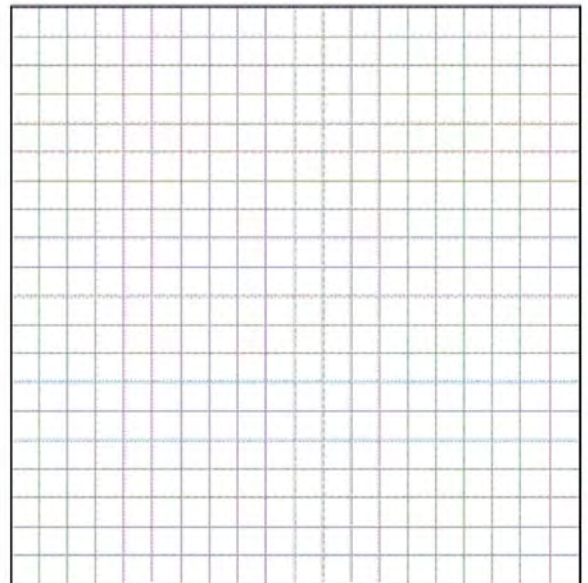

- 269 Which equation represents the axis of symmetry of the graph of the parabola below?

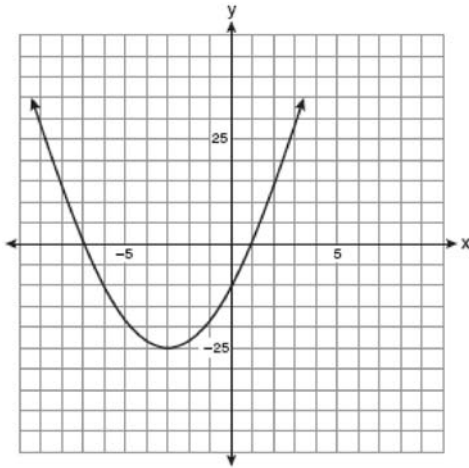

- 1) $y = -3$
 2) $x = -3$
 3) $y = -25$
 4) $x = -25$
- 270 The equations $5x + 2y = 48$ and $3x + 2y = 32$ represent the money collected from school concert ticket sales during two class periods. If x represents the cost for each adult ticket and y represents the cost for each student ticket, what is the cost for each adult ticket?

- 1) \$20
 2) \$10
 3) \$8
 4) \$4

- 271 Solve the following system of equations algebraically:

$$3x + 2y = 4$$

$$4x + 3y = 7$$

[Only an algebraic solution can receive full credit.]

- 272 Kathy plans to purchase a car that depreciates (loses value) at a rate of 14% per year. The initial cost of the car is \$21,000. Which equation represents the value, v , of the car after 3 years?

- 1) $v = 21,000(0.14)^3$
 2) $v = 21,000(0.86)^3$
 3) $v = 21,000(1.14)^3$
 4) $v = 21,000(0.86)(3)$

- 273 Which graph represents a function?

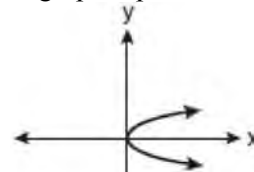

1)

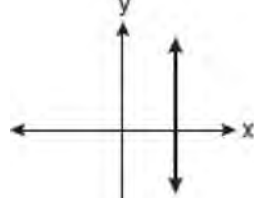

2)

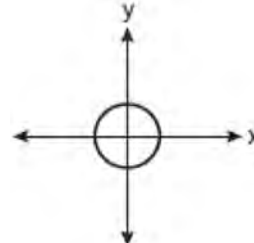

3)

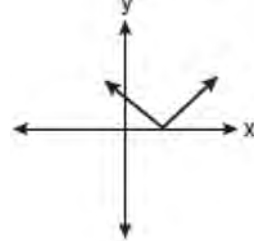

4)

- 274 On the set of axes below, solve the following system of equations graphically and state the coordinates of all points in the solution set.

$$y = x^2 + 4x - 5$$

$$y = x - 1$$

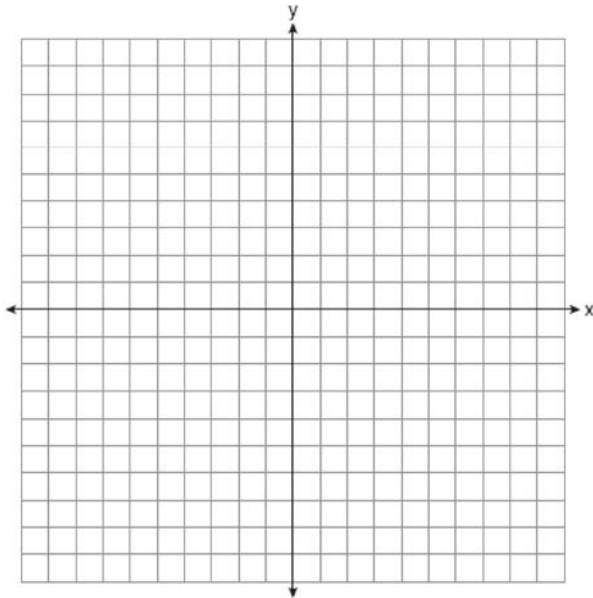

- 275 Tamara has a cell phone plan that charges \$0.07 per minute plus a monthly fee of \$19.00. She budgets \$29.50 per month for total cell phone expenses without taxes. What is the maximum number of minutes Tamara could use her phone each month in order to stay within her budget?

- 1) 150
- 2) 271
- 3) 421
- 4) 692

- 276 A playground in a local community consists of a rectangle and two semicircles, as shown in the diagram below.

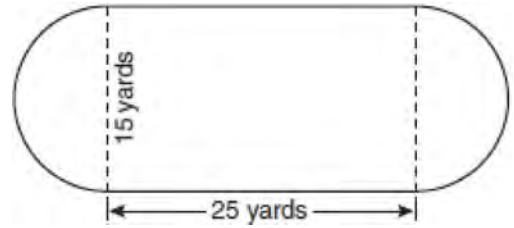

Which expression represents the amount of fencing, in yards, that would be needed to completely enclose the playground?

- 1) $15\pi + 50$
- 2) $15\pi + 80$
- 3) $30\pi + 50$
- 4) $30\pi + 80$

- 277 Peter begins his kindergarten year able to spell 10 words. He is going to learn to spell 2 new words every day. Write an inequality that can be used to determine how many days, d , it takes Peter to be able to spell *at least* 75 words. Use this inequality to determine the minimum number of whole days it will take for him to be able to spell *at least* 75 words.

- 278 What is the value of the third quartile shown on the box-and-whisker plot below?

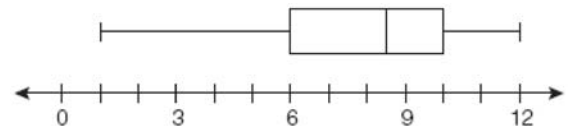

- 1) 6
- 2) 8.5
- 3) 10
- 4) 12

- 279 In the right triangle shown in the diagram below, what is the value of x to the *nearest whole number*?

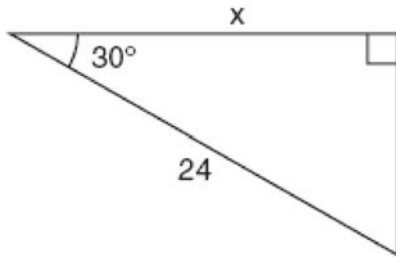

- 1) 12
 - 2) 14
 - 3) 21
 - 4) 28
- 280 The New York Volleyball Association invited 64 teams to compete in a tournament. After each round, half of the teams were eliminated. Which equation represents the number of teams, t , that remained in the tournament after r rounds?
- 1) $t = 64(r)^{0.5}$
 - 2) $t = 64(-0.5)^r$
 - 3) $t = 64(1.5)^r$
 - 4) $t = 64(0.5)^r$

- 281 What is the value of x , in inches, in the right triangle below?

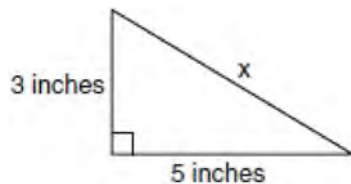

- 1) $\sqrt{15}$
- 2) 8
- 3) $\sqrt{34}$
- 4) 4

- 282 What are the vertex and the axis of symmetry of the parabola shown in the diagram below?

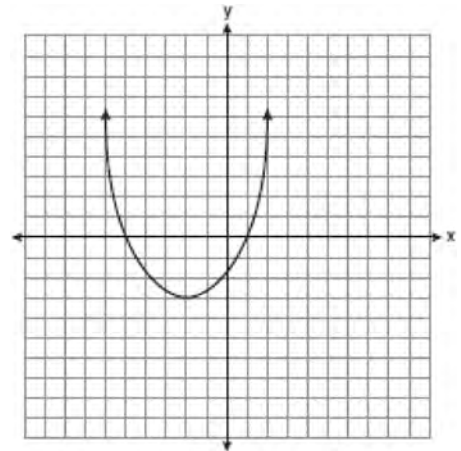

- 1) The vertex is $(-2, -3)$, and the axis of symmetry is $x = -2$.
 - 2) The vertex is $(-2, -3)$, and the axis of symmetry is $y = -2$.
 - 3) The vertex is $(-3, -2)$, and the axis of symmetry is $y = -2$.
 - 4) The vertex is $(-3, -2)$, and the axis of symmetry is $x = -2$.
- 283 If h represents a number, which equation is a correct translation of "Sixty more than 9 times a number is 375"?
- 1) $9h = 375$
 - 2) $9h + 60 = 375$
 - 3) $9h - 60 = 375$
 - 4) $60h + 9 = 375$

284 What is the sum of $\frac{d}{2}$ and $\frac{2d}{3}$ expressed in simplest form?

- 1) $\frac{3d}{5}$
- 2) $\frac{3d}{6}$
- 3) $\frac{7d}{5}$
- 4) $\frac{7d}{6}$

285 What is the solution of $\frac{k+4}{2} = \frac{k+9}{3}$?

- 1) 1
- 2) 5
- 3) 6
- 4) 14

286 The diagram below represents Joe's two fish tanks.

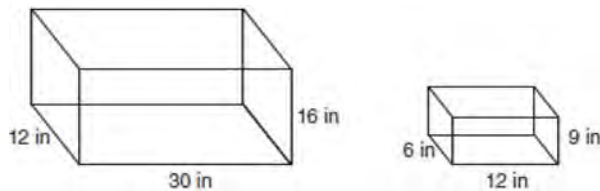

Joe's larger tank is completely filled with water. He takes water from it to completely fill the small tank. Determine how many cubic inches of water will remain in the larger tank.

287 Solve for x : $\frac{3}{5}(x+2) = x-4$

- 1) 8
- 2) 13
- 3) 15
- 4) 23

288 The local ice cream stand offers three flavors of soft-serve ice cream: vanilla, chocolate, and strawberry; two types of cone: sugar and wafer; and three toppings: sprinkles, nuts, and cookie crumbs. If Dawn does not order vanilla ice cream, how many different choices can she make that have one flavor of ice cream, one type of cone, and one topping?

- 1) 7
- 2) 8
- 3) 12
- 4) 18

289 Keisha is playing a game using a wheel divided into eight equal sectors, as shown in the diagram below. Each time the spinner lands on orange, she will win a prize.

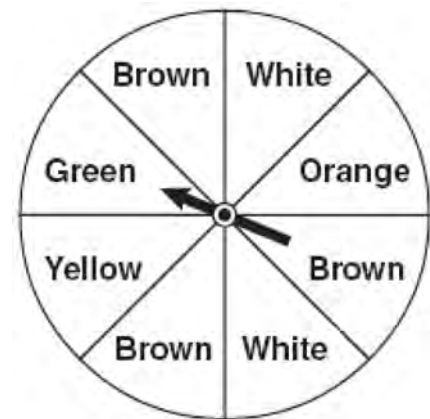

If Keisha spins this wheel twice, what is the probability she will win a prize on *both* spins?

- 1) $\frac{1}{64}$
- 2) $\frac{1}{56}$
- 3) $\frac{1}{16}$
- 4) $\frac{1}{4}$

290 Sarah measures her rectangular bedroom window for a new shade. Her measurements are 36 inches by 42 inches. The actual measurements of the window are 36.5 inches and 42.5 inches. Using the measurements that Sarah took, determine the number of square inches in the area of the window. Determine the number of square inches in the actual area of the window. Determine the relative error in calculating the area. Express your answer as a decimal to the *nearest thousandth*.

291 A contractor needs 54 square feet of brick to construct a rectangular walkway. The length of the walkway is 15 feet more than the width. Write an equation that could be used to determine the dimensions of the walkway. Solve this equation to find the length and width, in feet, of the walkway.

292 Which expression represents $\frac{25x - 125}{x^2 - 25}$ in simplest form?

- 1) $\frac{5}{x}$
- 2) $\frac{-5}{x}$
- 3) $\frac{25}{x - 5}$
- 4) $\frac{25}{x + 5}$

293 Write an equation that represents the line that passes through the points $(5, 4)$ and $(-5, 0)$.

294 The diagram below shows the graph of $y = |x - 3|$.

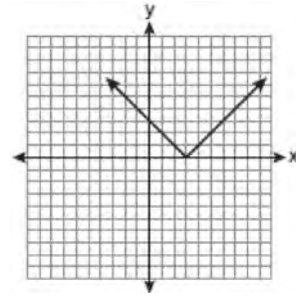

Which diagram shows the graph of $y = -|x - 3|$?

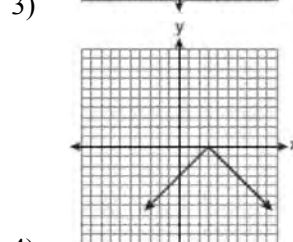
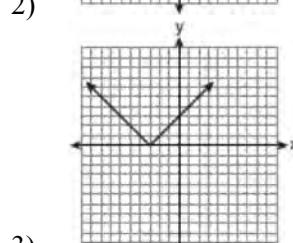
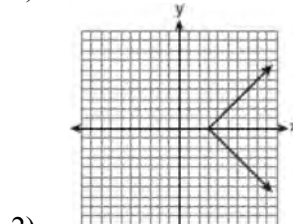
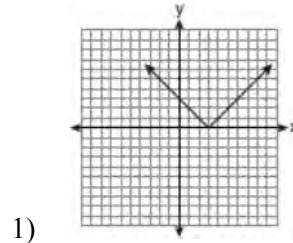

- 295 A tree casts a 25-foot shadow on a sunny day, as shown in the diagram below.

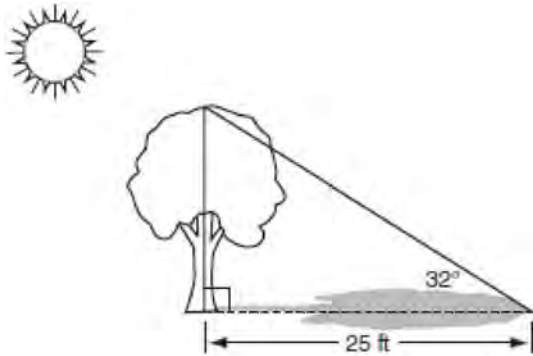

If the angle of elevation from the tip of the shadow to the top of the tree is 32° , what is the height of the tree to the nearest tenth of a foot?

- 1) 13.2
 - 2) 15.6
 - 3) 21.2
 - 4) 40.0
- 296 Which data set describes a situation that could be classified as qualitative?
- 1) the elevations of the five highest mountains in the world
 - 2) the ages of presidents at the time of their inauguration
 - 3) the opinions of students regarding school lunches
 - 4) the shoe sizes of players on the basketball team
- 297 Daniel's Print Shop purchased a new printer for \$35,000. Each year it depreciates (loses value) at a rate of 5%. What will its approximate value be at the end of the fourth year?
- 1) \$33,250.00
 - 2) \$30,008.13
 - 3) \$28,507.72
 - 4) \$27,082.33

- 298 Which graph represents a function?

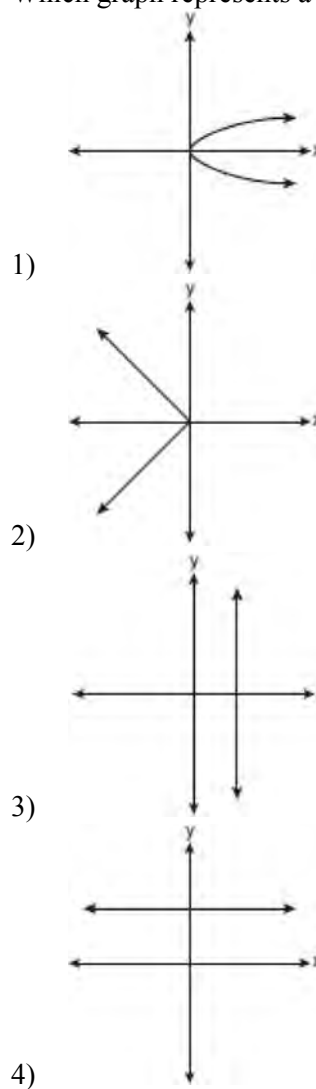

- 299 The length of a rectangular room is 7 less than three times the width, w , of the room. Which expression represents the area of the room?
- 1) $3w - 4$
 - 2) $3w - 7$
 - 3) $3w^2 - 4w$
 - 4) $3w^2 - 7w$

- 300 Pam is playing with red and black marbles. The number of red marbles she has is three more than twice the number of black marbles she has. She has 42 marbles in all. How many red marbles does Pam have?
- 1) 13
 - 2) 15
 - 3) 29
 - 4) 33

- 302 Which value of x is the solution of $\frac{2x}{5} + \frac{1}{3} = \frac{7x-2}{15}$?
- 1) $\frac{3}{5}$
 - 2) $\frac{31}{26}$
 - 3) 3
 - 4) 7

- 301 The prices of seven race cars sold last week are listed in the table below.

Price per Race Car	Number of Race Cars
\$126,000	1
\$140,000	2
\$180,000	1
\$400,000	2
\$819,000	1

What is the mean value of these race cars, in dollars? What is the median value of these race cars, in dollars? State which of these measures of central tendency best represents the value of the seven race cars. Justify your answer.

- 303 Graph the equation $y = x^2 - 2x - 3$ on the accompanying set of axes. Using the graph, determine the roots of the equation $x^2 - 2x - 3 = 0$.

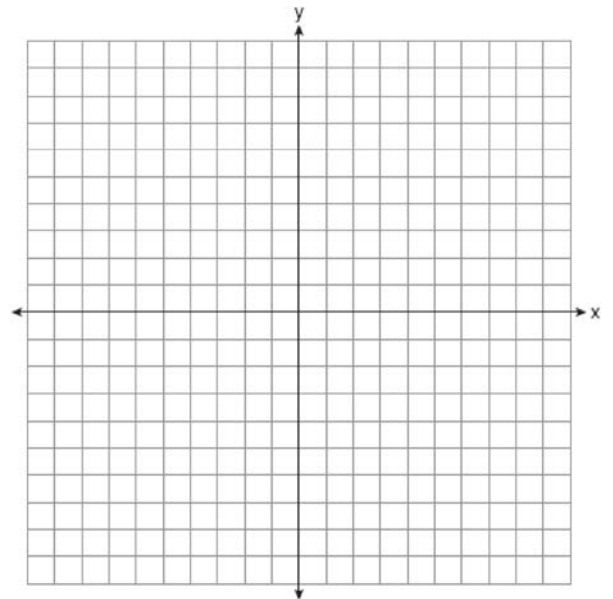

304 Sophie measured a piece of paper to be 21.7 cm by 28.5 cm. The piece of paper is actually 21.6 cm by 28.4 cm. Determine the number of square centimeters in the area of the piece of paper using Sophie's measurements. Determine the number of square centimeters in the actual area of the piece of paper. Determine the relative error in calculating the area. Express your answer as a decimal to the nearest thousandth. Sophie does not think there is a significant amount of error. Do you agree or disagree? Justify your answer.

305 What are the roots of the equation

$$x^2 - 10x + 21 = 0?$$

- 1) 1 and 21
- 2) -5 and -5
- 3) 3 and 7
- 4) -3 and -7

306 The equation $y = -x^2 - 2x + 8$ is graphed on the set of axes below.

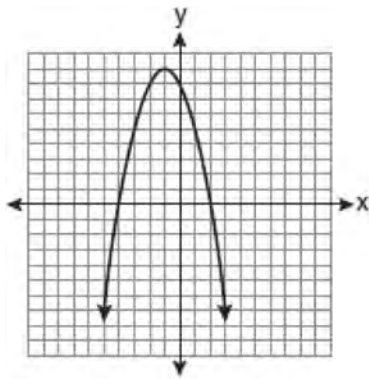

Based on this graph, what are the roots of the equation $-x^2 - 2x + 8 = 0$?

- 1) 8 and 0
- 2) 2 and -4
- 3) 9 and -1
- 4) 4 and -2

307 If $3ax + b = c$, then x equals

- 1) $c - b + 3a$
- 2) $c + b - 3a$
- 3) $\frac{c - b}{3a}$
- 4) $\frac{b - c}{3a}$

308 Solve the following systems of equations graphically, on the set of axes below, and state the coordinates of the point(s) in the solution set.

$$y = x^2 - 6x + 5$$

$$2x + y = 5$$

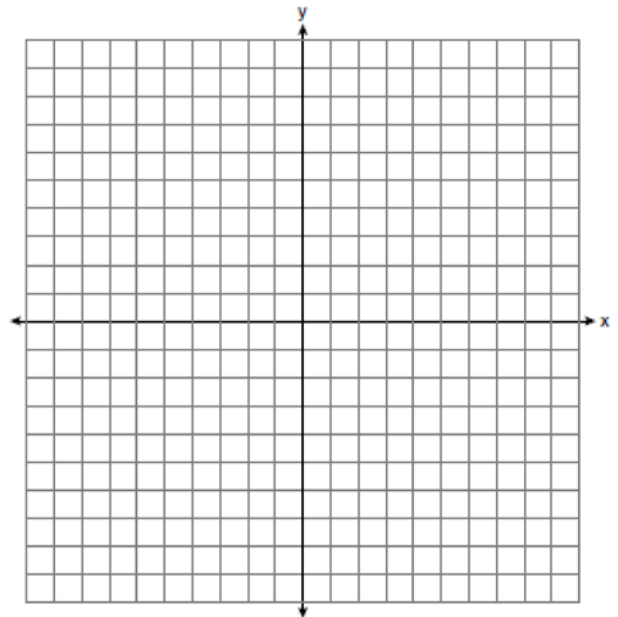

309 What is the value of the y -coordinate of the solution to the system of equations $x + 2y = 9$ and $x - y = 3$?

- 1) 6
- 2) 2
- 3) 3
- 4) 5

Integrated Algebra Regents Exam Questions at Random

www.jmap.org

- 310 Which relation is *not* a function?
- 1) $\{(1, 5), (2, 6), (3, 6), (4, 7)\}$
 - 2) $\{(4, 7), (2, 1), (-3, 6), (3, 4)\}$
 - 3) $\{(-1, 6), (1, 3), (2, 5), (1, 7)\}$
 - 4) $\{(-1, 2), (0, 5), (5, 0), (2, -1)\}$
- 311 Mrs. Smith wrote "Eight less than three times a number is greater than fifteen" on the board. If x represents the number, which inequality is a correct translation of this statement?
- 1) $3x - 8 > 15$
 - 2) $3x - 8 < 15$
 - 3) $8 - 3x > 15$
 - 4) $8 - 3x < 15$
- 312 A soup can is in the shape of a cylinder. The can has a volume of 342 cm^3 and a diameter of 6 cm. Express the height of the can in terms of π . Determine the maximum number of soup cans that can be stacked on their base between two shelves if the distance between the shelves is exactly 36 cm. Explain your answer.
- 313 Solve for g : $3 + 2g = 5g - 9$
- 314 Mrs. Ayer is painting the outside of her son's toy box, including the top and bottom. The toy box measures 3 feet long, 1.5 feet wide, and 2 feet high. What is the total surface area she will paint?
- 1) 9.0 ft^2
 - 2) 13.5 ft^2
 - 3) 22.5 ft^2
 - 4) 27.0 ft^2
- 315 Which relationship can best be described as causal?
- 1) height and intelligence
 - 2) shoe size and running speed
 - 3) number of correct answers on a test and test score
 - 4) number of students in a class and number of students with brown hair
- 316 Throughout history, many people have contributed to the development of mathematics. These mathematicians include Pythagoras, Euclid, Hypatia, Euler, Einstein, Agnesi, Fibonacci, and Pascal. What is the probability that a mathematician's name selected at random from those listed will start with either the letter E or the letter A ?
- 1) $\frac{2}{8}$
 - 2) $\frac{3}{8}$
 - 3) $\frac{4}{8}$
 - 4) $\frac{6}{8}$
- 317 The faces of a cube are numbered from 1 to 6. If the cube is tossed once, what is the probability that a prime number or a number divisible by 2 is obtained?
- 1) $\frac{6}{6}$
 - 2) $\frac{5}{6}$
 - 3) $\frac{4}{6}$
 - 4) $\frac{1}{6}$

- 318 What is half of 2^6 ?
- 1) 1^3
 - 2) 1^6
 - 3) 2^3
 - 4) 2^5
- 319 The bowling team at Lincoln High School must choose a president, vice president, and secretary. If the team has 10 members, which expression could be used to determine the number of ways the officers could be chosen?
- 1) ${}_3P_{10}$
 - 2) ${}_7P_3$
 - 3) ${}_{10}P_3$
 - 4) ${}_{10}P_7$
- 320 What is an equation of the line that passes through the point $(4, -6)$ and has a slope of -3 ?
- 1) $y = -3x + 6$
 - 2) $y = -3x - 6$
 - 3) $y = -3x + 10$
 - 4) $y = -3x + 14$
- 321 Which data set describes a situation that could be classified as qualitative?
- 1) the ages of the students in Ms. Marshall's Spanish class
 - 2) the test scores of the students in Ms. Fitzgerald's class
 - 3) the favorite ice cream flavor of each of Mr. Hayden's students
 - 4) the heights of the players on the East High School basketball team
- 322 If $a + ar = b + r$, the value of a in terms of b and r can be expressed as
- 1) $\frac{b}{r} + 1$
 - 2) $\frac{1+b}{r}$
 - 3) $\frac{b+r}{1+r}$
 - 4) $\frac{1+b}{r+b}$
- 323 What is the product of $\frac{4x}{x-1}$ and $\frac{x^2-1}{3x+3}$ expressed in simplest form?
- 1) $\frac{4x}{3}$
 - 2) $\frac{4x^2}{3}$
 - 3) $\frac{4x^2}{3(x+1)}$
 - 4) $\frac{4(x+1)}{3}$
- 324 Which situation describes a correlation that is *not* a causal relationship?
- 1) The rooster crows, and the Sun rises.
 - 2) The more miles driven, the more gasoline needed
 - 3) The more powerful the microwave, the faster the food cooks.
 - 4) The faster the pace of a runner, the quicker the runner finishes.

- 325 Rhonda has \$1.35 in nickels and dimes in her pocket. If she has six more dimes than nickels, which equation can be used to determine x , the number of nickels she has?
- 1) $0.05(x + 6) + 0.10x = 1.35$
 - 2) $0.05x + 0.10(x + 6) = 1.35$
 - 3) $0.05 + 0.10(6x) = 1.35$
 - 4) $0.15(x + 6) = 1.35$

- 326 A window is made up of a single piece of glass in the shape of a semicircle and a rectangle, as shown in the diagram below. Tess is decorating for a party and wants to put a string of lights all the way around the outside edge of the window.

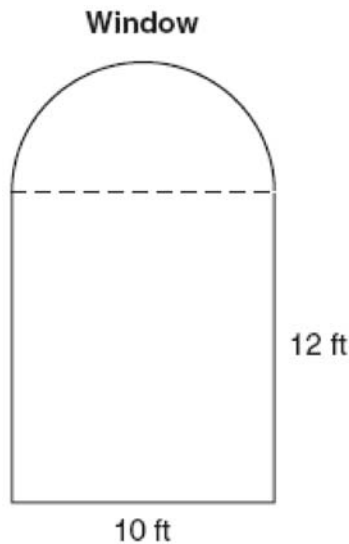

To the *nearest foot*, what is the length of the string of lights that Tess will need to decorate the window?

- 327 Which value of x is in the solution set of the inequality $-2(x - 5) < 4$?
- 1) 0
 - 2) 2
 - 3) 3
 - 4) 5
- 328 Ryan estimates the measurement of the volume of a popcorn container to be 282 cubic inches. The actual volume of the popcorn container is 289 cubic inches. What is the relative error of Ryan's measurement to the *nearest thousandth*?
- 1) 0.024
 - 2) 0.025
 - 3) 0.096
 - 4) 1.025

- 329 The test scores from Mrs. Gray's math class are shown below.
72, 73, 66, 71, 82, 85, 95, 85, 86, 89, 91, 92
Construct a box-and-whisker plot to display these data.

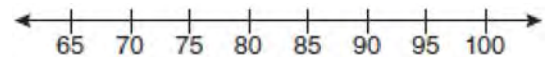

- 330 What is an equation of the line that passes through the point $(3, -1)$ and has a slope of 2?
- 1) $y = 2x + 5$
 - 2) $y = 2x - 1$
 - 3) $y = 2x - 4$
 - 4) $y = 2x - 7$

331 Which graph represents the solution of $3y - 9 \leq 6x$?

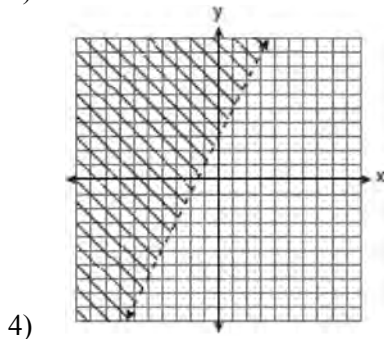
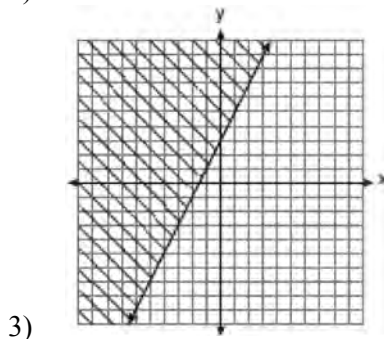
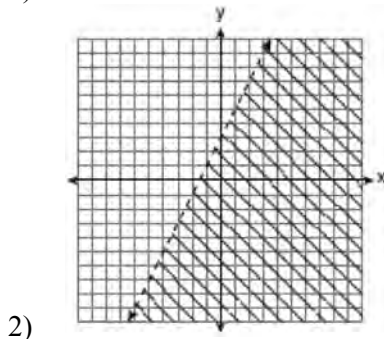
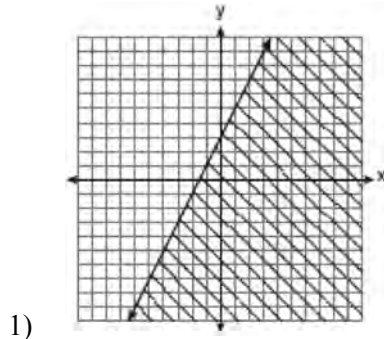

333 The values of 11 houses on Washington St. are shown in the table below.

Value per House	Number of Houses
\$100,000	1
\$175,000	5
\$200,000	4
\$700,000	1

Find the mean value of these houses in dollars.
 Find the median value of these houses in dollars.
 State which measure of central tendency, the mean or the median, *best* represents the values of these 11 houses. Justify your answer.

334 The table below represents the number of hours a student worked and the amount of money the student earned.

Number of Hours (h)	Dollars Earned (d)
8	\$50.00
15	\$93.75
19	\$118.75
30	\$187.50

Write an equation that represents the number of dollars, d , earned in terms of the number of hours, h , worked. Using this equation, determine the number of dollars the student would earn for working 40 hours.

332 Express $5\sqrt{72}$ in simplest radical form.

- 335 Antwaan leaves a cup of hot chocolate on the counter in his kitchen. Which graph is the best representation of the change in temperature of his hot chocolate over time?

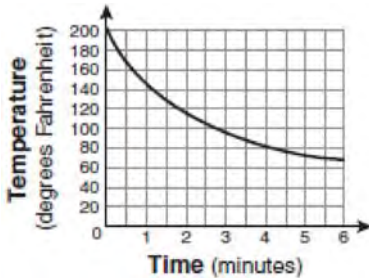

1)

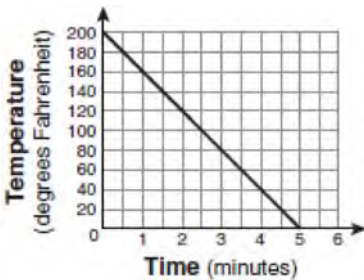

2)

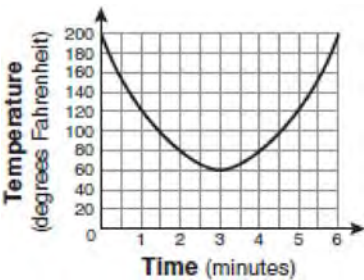

3)

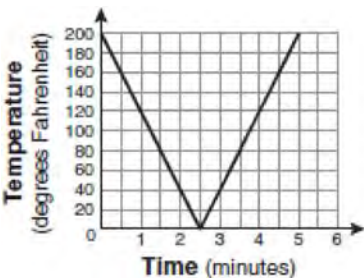

4)

- 336 Which equation represents a line that is parallel to the line $y = -4x + 5$?

- 1) $y = -4x + 3$
- 2) $y = -\frac{1}{4}x + 5$
- 3) $y = \frac{1}{4}x + 3$
- 4) $y = 4x + 5$

- 337 A restaurant sells kids' meals consisting of one main course, one side dish, and one drink, as shown in the table below.

Kids' Meal Choices

Main Course	Side Dish	Drink
hamburger	French fries	milk
chicken nuggets	applesauce	juice
turkey sandwich		soda

Draw a tree diagram or list the sample space showing all possible kids' meals. How many different kids' meals can a person order? Jose does not drink juice. Determine the number of different kids' meals that do *not* include juice. Jose's sister will eat *only* chicken nuggets for her main course. Determine the number of different kids' meals that include chicken nuggets.

- 338 Given:

$$\text{Set } A = \{(-2, -1), (-1, 0), (1, 8)\}$$

$$\text{Set } B = \{(-3, -4), (-2, -1), (-1, 2), (1, 8)\}.$$

What is the intersection of sets A and B ?

- 1) $\{(1, 8)\}$
- 2) $\{(-2, -1)\}$
- 3) $\{(-2, -1), (1, 8)\}$
- 4) $\{(-3, -4), (-2, -1), (-1, 2), (-1, 0), (1, 8)\}$

- 339 Tanya runs diagonally across a rectangular field that has a length of 40 yards and a width of 30 yards, as shown in the diagram below.

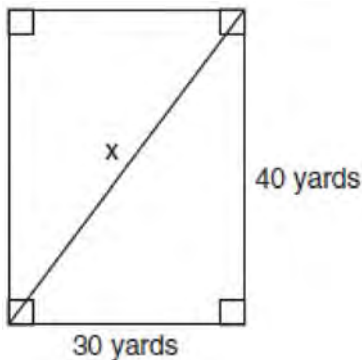

What is the length of the diagonal, in yards, that Tanya runs?

- 1) 50
 - 2) 60
 - 3) 70
 - 4) 80
- 340 The box-and-whisker plot below represents students' scores on a recent English test.

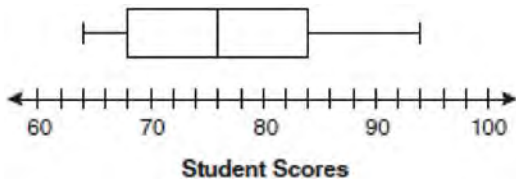

What is the value of the upper quartile?

- 1) 68
- 2) 76
- 3) 84
- 4) 94

- 341 What is the slope of the line that passes through the points (2, 5) and (7, 3)?

- 1) $-\frac{5}{2}$
- 2) $-\frac{2}{5}$
- 3) $\frac{8}{9}$
- 4) $\frac{9}{8}$

- 342 Mr. Laub has three children: two girls (Sue and Karen) and one boy (David). After each meal, one child is chosen at random to wash dishes. If the same child can be chosen for both lunch and dinner, construct a tree diagram or list a sample space of all the possible outcomes of who will wash dishes after lunch and dinner on Saturday. Determine the probability that one boy and one girl will wash dishes after lunch and dinner on Saturday.

- 343 A movie theater recorded the number of tickets sold daily for a popular movie during the month of June. The box-and-whisker plot shown below represents the data for the number of tickets sold, in hundreds.

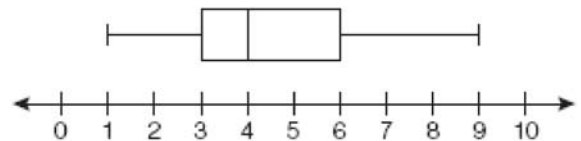

Which conclusion can be made using this plot?

- 1) The second quartile is 600.
- 2) The mean of the attendance is 400.
- 3) The range of the attendance is 300 to 600.
- 4) Twenty-five percent of the attendance is between 300 and 400.

- 344 Carrie bought new carpet for her living room. She calculated the area of the living room to be 174.2 square feet. The actual area was 149.6 square feet. What is the relative error of the area to the *nearest ten-thousandth*?
- 1) 0.1412
 - 2) 0.1644
 - 3) 1.8588
 - 4) 2.1644

- 345 Some books are laid on a desk. Two are English, three are mathematics, one is French, and four are social studies. Theresa selects an English book and Isabelle then selects a social studies book. Both girls take their selections to the library to read. If Truman then selects a book at random, what is the probability that he selects an English book?

- 346 Which equation is represented by the graph below?

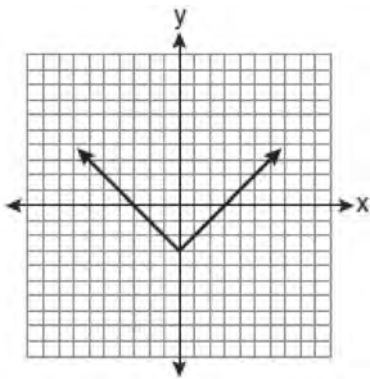

- 1) $y = x^2 - 3$
- 2) $y = (x - 3)^2$
- 3) $y = |x| - 3$
- 4) $y = |x - 3|$

- 347 On the set of axes below, graph the following system of inequalities and state the coordinates of a point in the solution set.

$$2x - y \geq 6$$

$$x > 2$$

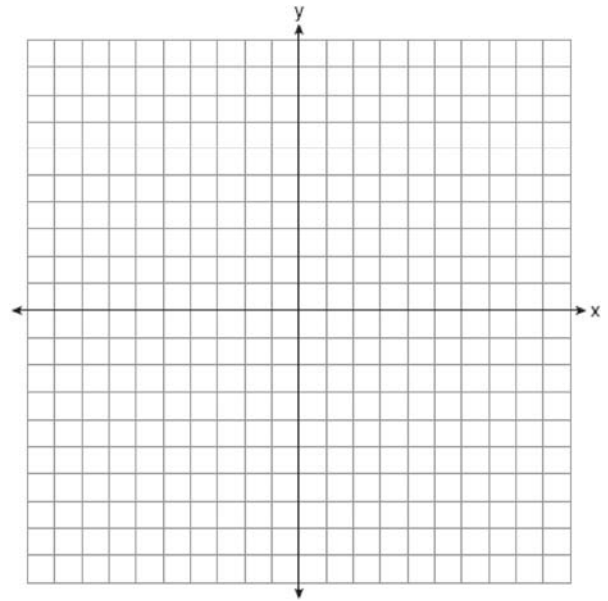

- 348 Express in simplest form: $\frac{2x^2 - 8x - 42}{6x^2} \div \frac{x^2 - 9}{x^2 - 3x}$

- 349 What is the value of the expression $|-5x + 12|$ when $x = 5$?

- 1) -37
- 2) -13
- 3) 13
- 4) 37

- 350 Jack bought 3 slices of cheese pizza and 4 slices of mushroom pizza for a total cost of \$12.50. Grace bought 3 slices of cheese pizza and 2 slices of mushroom pizza for a total cost of \$8.50. What is the cost of one slice of mushroom pizza?
- 1) \$1.50
 - 2) \$2.00
 - 3) \$3.00
 - 4) \$3.50
- 351 What is $\frac{\sqrt{32}}{4}$ expressed in simplest radical form?
- 1) $\sqrt{2}$
 - 2) $4\sqrt{2}$
 - 3) $\sqrt{8}$
 - 4) $\frac{\sqrt{8}}{2}$
- 352 Which interval notation represents the set of all numbers from 2 through 7, inclusive?
- 1) (2, 7]
 - 2) (2, 7)
 - 3) [2, 7)
 - 4) [2, 7]
- 353 Find algebraically the equation of the axis of symmetry and the coordinates of the vertex of the parabola whose equation is $y = -2x^2 - 8x + 3$.
- 354 Alex earned scores of 60, 74, 82, 87, 87, and 94 on his first six algebra tests. What is the relationship between the measures of central tendency of these scores?
- 1) median < mode < mean
 - 2) mean < mode < median
 - 3) mode < median < mean
 - 4) mean < median < mode
- 355 The length of a rectangular window is 5 feet more than its width, w . The area of the window is 36 square feet. Which equation could be used to find the dimensions of the window?
- 1) $w^2 + 5w + 36 = 0$
 - 2) $w^2 - 5w - 36 = 0$
 - 3) $w^2 - 5w + 36 = 0$
 - 4) $w^2 + 5w - 36 = 0$
- 356 A survey is being conducted to determine which types of television programs people watch. Which survey and location combination would likely contain the most bias?
- 1) surveying 10 people who work in a sporting goods store
 - 2) surveying the first 25 people who enter a grocery store
 - 3) randomly surveying 50 people during the day in a mall
 - 4) randomly surveying 75 people during the day in a clothing store
- 357 What is the additive inverse of the expression $a - b$?
- 1) $a + b$
 - 2) $a - b$
 - 3) $-a + b$
 - 4) $-a - b$

- 358 Which statement is true about the relation shown on the graph below?

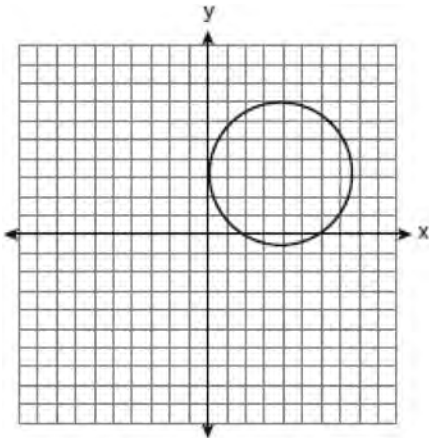

- 1) It is a function because there exists one x -coordinate for each y -coordinate.
- 2) It is a function because there exists one y -coordinate for each x -coordinate.
- 3) It is *not* a function because there are multiple y -values for a given x -value.
- 4) It is *not* a function because there are multiple x -values for a given y -value.

- 359 The chart below compares two runners.

Runner	Distance, in miles	Time, in hours
Greg	11	2
Dave	16	3

Based on the information in this chart, state which runner has the faster rate. Justify your answer.

- 360 On the set of axes below, draw the graph of $y = 2^x$ over the interval $-1 \leq x \leq 3$. Will this graph ever intersect the x -axis? Justify your answer.

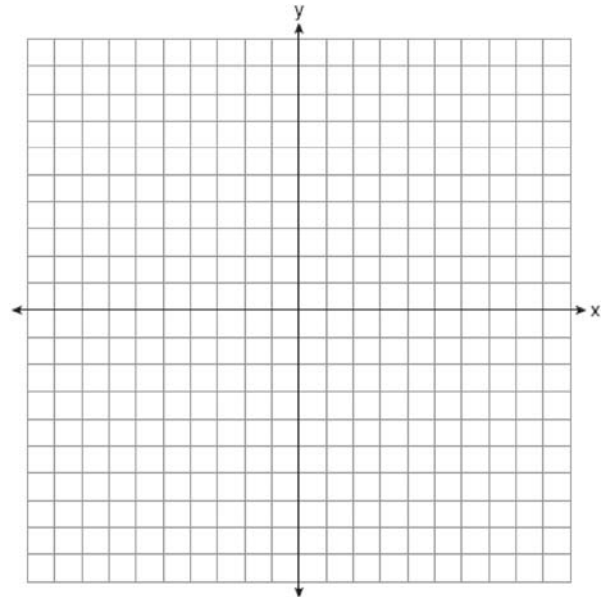

- 361 When $3g^2 - 4g + 2$ is subtracted from $7g^2 + 5g - 1$, the difference is

- 1) $-4g^2 - 9g + 3$
- 2) $4g^2 + g + 1$
- 3) $4g^2 + 9g - 3$
- 4) $10g^2 + g + 1$

- 362 Mr. Turner bought x boxes of pencils. Each box holds 25 pencils. He left 3 boxes of pencils at home and took the rest to school. Which expression represents the total number of pencils he took to school?

- 1) $22x$
- 2) $25x - 3$
- 3) $25 - 3x$
- 4) $25x - 75$

363 Which expression is equivalent to $(3x^2)^3$?

- 1) $9x^5$
- 2) $9x^6$
- 3) $27x^5$
- 4) $27x^6$

364 An electronics store sells DVD players and cordless telephones. The store makes a \$75 profit on the sale of each DVD player (d) and a \$30 profit on the sale of each cordless telephone (c). The store wants to make a profit of at least \$255.00 from its sales of DVD players and cordless phones. Which inequality describes this situation?

- 1) $75d + 30c < 255$
- 2) $75d + 30c \leq 255$
- 3) $75d + 30c > 255$
- 4) $75d + 30c \geq 255$

365 In a linear equation, the independent variable increases at a constant rate while the dependent variable decreases at a constant rate. The slope of this line is

- 1) zero
- 2) negative
- 3) positive
- 4) undefined

366 It takes Tammy 45 minutes to ride her bike 5 miles. At this rate, how long will it take her to ride 8 miles?

- 1) 0.89 hour
- 2) 1.125 hours
- 3) 48 minutes
- 4) 72 minutes

367 What is the product of $-3x^2y$ and $(5xy^2 + xy)$?

- 1) $-15x^3y^3 - 3x^3y^2$
- 2) $-15x^3y^3 - 3x^3y$
- 3) $-15x^2y^2 - 3x^2y$
- 4) $-15x^3y^3 + xy$

368 The spinner below is divided into eight equal regions and is spun once. What is the probability of *not* getting red?

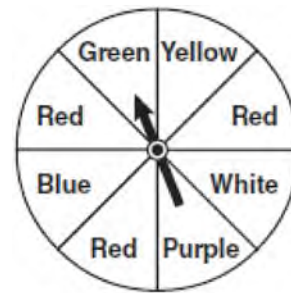

- 1) $\frac{3}{5}$
- 2) $\frac{3}{8}$
- 3) $\frac{5}{8}$
- 4) $\frac{7}{8}$

369 The statement $2 + 0 = 2$ is an example of the use of which property of real numbers?

- 1) associative
- 2) additive identity
- 3) additive inverse
- 4) distributive

- 370 Which inequality is represented by the graph below?

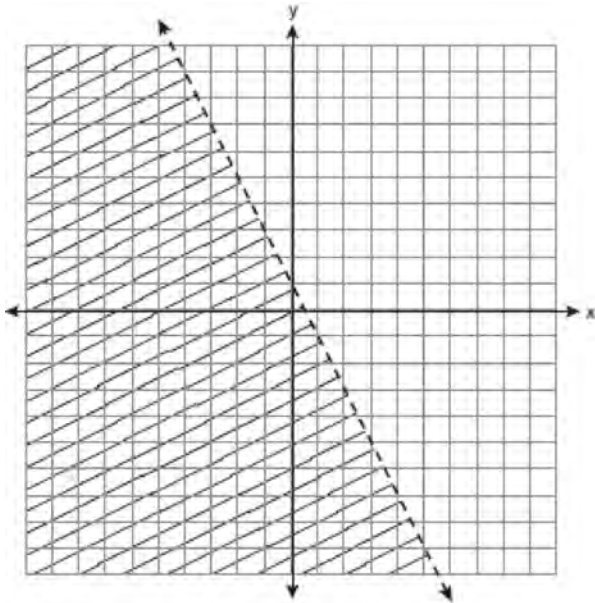

- 1) $y < 2x + 1$
 2) $y < -2x + 1$
 3) $y < \frac{1}{2}x + 1$
 4) $y < -\frac{1}{2}x + 1$
- 371 Consider the set of integers greater than -2 and less than 6 . A subset of this set is the positive factors of 5 . What is the complement of this subset?
- 1) $\{0, 2, 3, 4\}$
 2) $\{-1, 0, 2, 3, 4\}$
 3) $\{-2, -1, 0, 2, 3, 4, 6\}$
 4) $\{-2, -1, 0, 1, 2, 3, 4, 5, 6\}$

372 Simplify: $\frac{27k^5m^8}{(4k^3)(9m^2)}$

- 373 A prom ticket at Smith High School is \$120. Tom is going to save money for the ticket by walking his neighbor's dog for \$15 per week. If Tom already has saved \$22, what is the minimum number of weeks Tom must walk the dog to earn enough to pay for the prom ticket?

- 374 What is the product of $\frac{x^2 - 1}{x + 1}$ and $\frac{x + 3}{3x - 3}$ expressed in simplest form?

- 1) x
 2) $\frac{x}{3}$
 3) $x + 3$
 4) $\frac{x + 3}{3}$

- 375 At Genesee High School, the sophomore class has 60 more students than the freshman class. The junior class has 50 fewer students than twice the students in the freshman class. The senior class is three times as large as the freshman class. If there are a total of 1,424 students at Genesee High School, how many students are in the freshman class?

- 1) 202
 2) 205
 3) 235
 4) 236

- 376 Tim ate four more cookies than Alice. Bob ate twice as many cookies as Tim. If x represents the number of cookies Alice ate, which expression represents the number of cookies Bob ate?

- 1) $2 + (x + 4)$
 2) $2x + 4$
 3) $2(x + 4)$
 4) $4(x + 2)$

377 Which verbal expression represents $2(n - 6)$?

- 1) two times n minus six
- 2) two times six minus n
- 3) two times the quantity n less than six
- 4) two times the quantity six less than n

378 Marie currently has a collection of 58 stamps. If she buys s stamps each week for w weeks, which expression represents the total number of stamps she will have?

- 1) $58sw$
- 2) $58 + sw$
- 3) $58s + w$
- 4) $58 + s + w$

379 The center pole of a tent is 8 feet long, and a side of the tent is 12 feet long as shown in the diagram below.

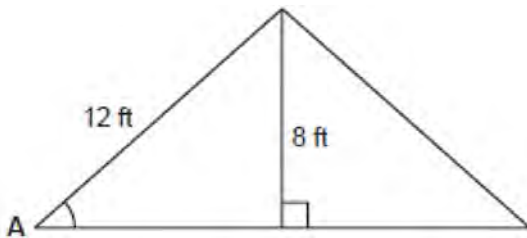

If a right angle is formed where the center pole meets the ground, what is the measure of angle A to the nearest degree?

- 1) 34
- 2) 42
- 3) 48
- 4) 56

380 The sign shown below is posted in front of a roller coaster ride at the Wadsworth County Fairgrounds.

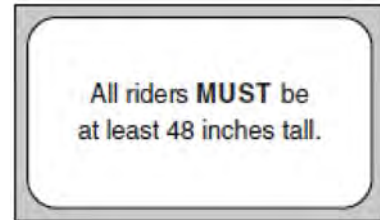

If h represents the height of a rider in inches, what is a correct translation of the statement on this sign?

- 1) $h < 48$
- 2) $h > 48$
- 3) $h \leq 48$
- 4) $h \geq 48$

381 What is $\sqrt{32}$ expressed in simplest radical form?

- 1) $16\sqrt{2}$
- 2) $4\sqrt{2}$
- 3) $4\sqrt{8}$
- 4) $2\sqrt{8}$

382 What is the slope of the line that passes through the points $(-6, 1)$ and $(4, -4)$?

- 1) -2
- 2) 2
- 3) $-\frac{1}{2}$
- 4) $\frac{1}{2}$

- 383 The set $\{11, 12\}$ is equivalent to
- 1) $\{x | 11 < x < 12, \text{ where } x \text{ is an integer}\}$
 - 2) $\{x | 11 < x \leq 12, \text{ where } x \text{ is an integer}\}$
 - 3) $\{x | 10 \leq x < 12, \text{ where } x \text{ is an integer}\}$
 - 4) $\{x | 10 < x \leq 12, \text{ where } x \text{ is an integer}\}$

384 Which equation represents a line parallel to the x -axis?

- 1) $x = 5$
- 2) $y = 10$
- 3) $x = \frac{1}{3}y$
- 4) $y = 5x + 17$

385 On the set of axes below, solve the following system of equations graphically for all values of x and y .

$$y = x^2 - 6x + 1$$

$$y + 2x = 6$$

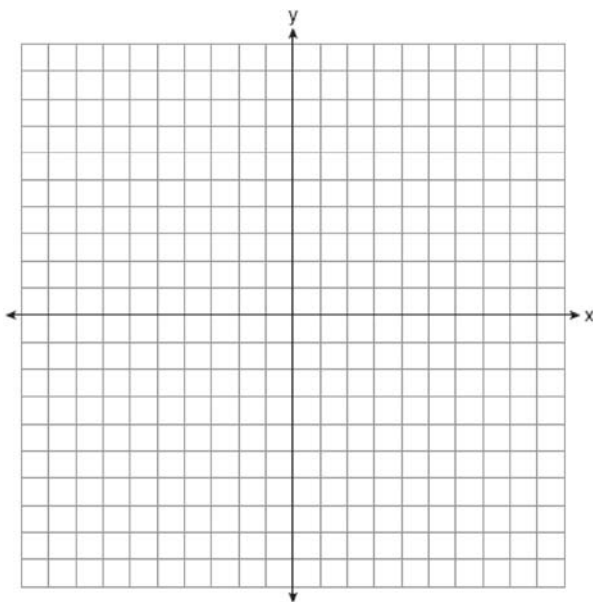

386 There is a negative correlation between the number of hours a student watches television and his or her social studies test score. Which scatter plot below displays this correlation?

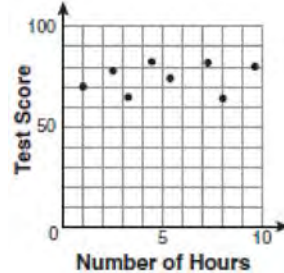

1)

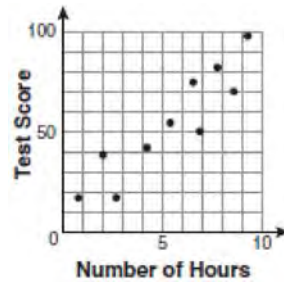

2)

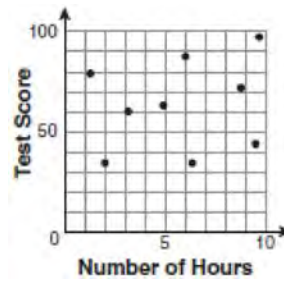

3)

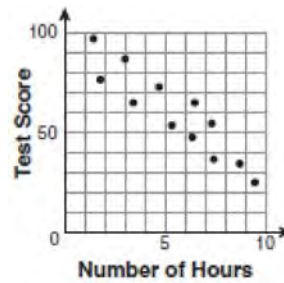

4)

- 387 Don placed a ladder against the side of his house as shown in the diagram below.

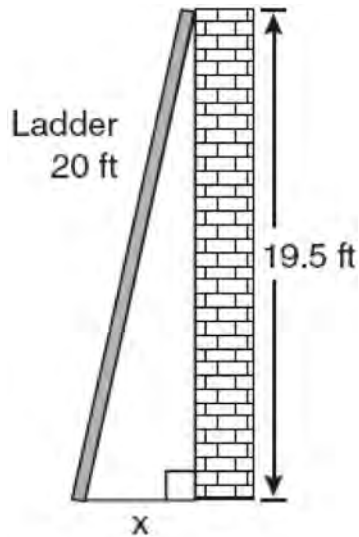

Which equation could be used to find the distance, x , from the foot of the ladder to the base of the house?

- 1) $x = 20 - 19.5$
 - 2) $x = 20^2 - 19.5^2$
 - 3) $x = \sqrt{20^2 - 19.5^2}$
 - 4) $x = \sqrt{20^2 + 19.5^2}$
- 388 Perform the indicated operation and simplify:
- $$\frac{3x+6}{4x+12} \div \frac{x^2-4}{x+3}$$
- 389 The faces of a cube are numbered from 1 to 6. If the cube is rolled once, which outcome is *least* likely to occur?
- 1) rolling an odd number
 - 2) rolling an even number
 - 3) rolling a number less than 6
 - 4) rolling a number greater than 4

- 390 Serena's garden is a rectangle joined with a semicircle, as shown in the diagram below. Line segment AB is the diameter of semicircle P . Serena wants to put a fence around her garden.

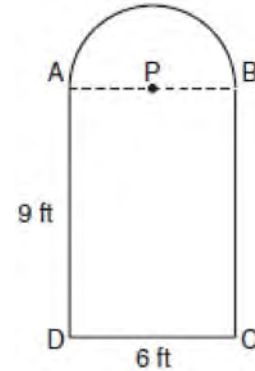

Calculate the length of fence Serena needs to the nearest tenth of a foot.

- 391 Which statement is true about the data set 3, 4, 5, 6, 7, 7, 10?
- 1) mean = mode
 - 2) mean > mode
 - 3) mean = median
 - 4) mean < median
- 392 In a game of ice hockey, the hockey puck took 0.8 second to travel 89 feet to the goal line. Determine the average speed of the puck in feet per second.
- 393 Determine how many three-letter arrangements are possible with the letters A , N , G , L , and E if no letter may be repeated.

- 394 For 10 days, Romero kept a record of the number of hours he spent listening to music. The information is shown in the table below.

Day	1	2	3	4	5	6	7	8	9	10
Hours	9	3	2	6	8	6	10	4	5	2

Which scatter plot shows Romero's data graphically?

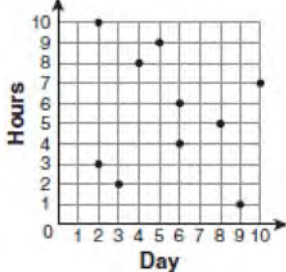

1)

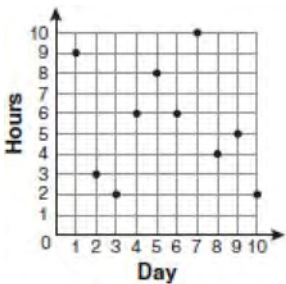

2)

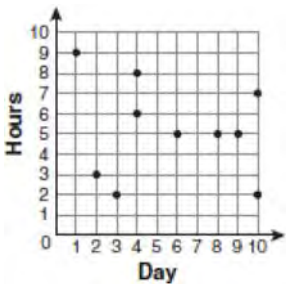

3)

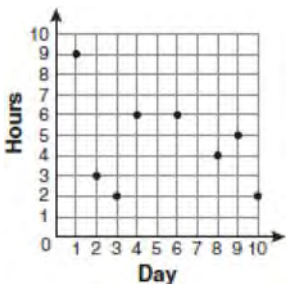

4)

- 395 For which value of x is $\frac{x-3}{x^2-4}$ undefined?

- 1) -2
- 2) 0
- 3) 3
- 4) 4

- 396 What is the quotient of 8.05×10^6 and 3.5×10^2 ?

- 1) 2.3×10^3
- 2) 2.3×10^4
- 3) 2.3×10^8
- 4) 2.3×10^{12}

- 397 What are the vertex and axis of symmetry of the parabola $y = x^2 - 16x + 63$?

- 1) vertex: $(8, -1)$; axis of symmetry: $x = 8$
- 2) vertex: $(8, 1)$; axis of symmetry: $x = 8$
- 3) vertex: $(-8, -1)$; axis of symmetry: $x = -8$
- 4) vertex: $(-8, 1)$; axis of symmetry: $x = -8$

- 398 When $4x^2 + 7x - 5$ is subtracted from $9x^2 - 2x + 3$, the result is

- 1) $5x^2 + 5x - 2$
- 2) $5x^2 - 9x + 8$
- 3) $-5x^2 + 5x - 2$
- 4) $-5x^2 + 9x - 8$

- 399 A spinner is divided into eight equal regions as shown in the diagram below.

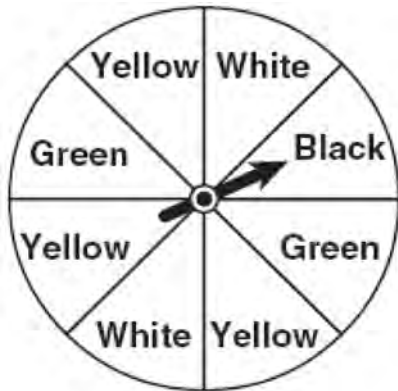

Which event is most likely to occur in one spin?

- 1) The arrow will land in a green or white area.
 - 2) The arrow will land in a green or black area.
 - 3) The arrow will land in a yellow or black area.
 - 4) The arrow will land in a yellow or green area.
- 400 What is the product of 12 and 4.2×10^6 expressed in scientific notation?
- 1) 50.4×10^6
 - 2) 50.4×10^7
 - 3) 5.04×10^6
 - 4) 5.04×10^7
- 401 What is the sum of $\frac{3}{2x}$ and $\frac{4}{3x}$ expressed in simplest form?
- 1) $\frac{12}{6x^2}$
 - 2) $\frac{17}{6x}$
 - 3) $\frac{7}{5x}$
 - 4) $\frac{17}{12x}$

- 402 What are the roots of the equation $x^2 - 5x + 6 = 0$?
- 1) 1 and -6
 - 2) 2 and 3
 - 3) -1 and 6
 - 4) -2 and -3

- 403 Which equation represents a line that is parallel to the line $y = 3 - 2x$?
- 1) $4x + 2y = 5$
 - 2) $2x + 4y = 1$
 - 3) $y = 3 - 4x$
 - 4) $y = 4x - 2$

- 404 Lenny made a cube in technology class. Each edge measured 1.5 cm. What is the volume of the cube in cubic centimeters?
- 1) 2.25
 - 2) 3.375
 - 3) 9.0
 - 4) 13.5

- 405 Sam and Odel have been selling frozen pizzas for a class fundraiser. Sam has sold half as many pizzas as Odel. Together they have sold a total of 126 pizzas. How many pizzas did Sam sell?
- 1) 21
 - 2) 42
 - 3) 63
 - 4) 84

- 406 Maureen tracks the range of outdoor temperatures over three days. She records the following information.

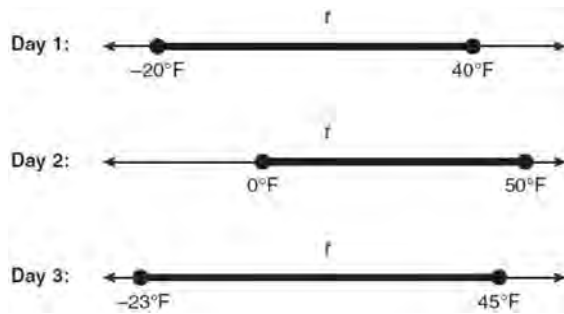

Express the intersection of the three sets as an inequality in terms of temperature, t .

- 407 Brianna is using the two spinners shown below to play her new board game. She spins the arrow on each spinner once. Brianna uses the first spinner to determine how many spaces to move. She uses the second spinner to determine whether her move from the first spinner will be forward or backward.



Find the probability that Brianna will move *fewer than* four spaces and *backward*.

- 408 The solution to the equation $x^2 - 6x = 0$ is
- 1) 0, only
 - 2) 6, only
 - 3) 0 and 6
 - 4) $\pm\sqrt{6}$

- 409 The equation $y = x^2 + 3x - 18$ is graphed on the set of axes below.

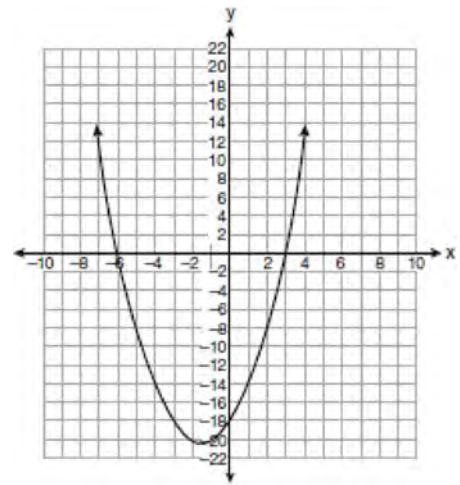

Based on this graph, what are the roots of the equation $x^2 + 3x - 18 = 0$?

- 1) -3 and 6
 - 2) 0 and -18
 - 3) 3 and -6
 - 4) 3 and -18
- 410 The groundskeeper is replacing the turf on a football field. His measurements of the field are 130 yards by 60 yards. The actual measurements are 120 yards by 54 yards. Which expression represents the relative error in the measurement?
- 1) $\frac{(130)(60) - (120)(54)}{(120)(54)}$
 - 2) $\frac{(120)(54)}{(130)(60) - (120)(54)}$
 - 3) $\frac{(130)(60) - (120)(54)}{(130)(60)}$
 - 4) $\frac{(130)(60)}{(130)(60) - (120)(54)}$

- 411 Which value of x is in the solution set of the inequality $-4x + 2 > 10$?
- 1) -2
 - 2) 2
 - 3) 3
 - 4) -4

- 412 Twenty students were surveyed about the number of days they played outside in one week. The results of this survey are shown below.
 $\{6,5,4,3,0,7,1,5,4,4,3,2,2,3,2,4,3,4,0,7\}$
 Complete the frequency table below for these data.

Interval	Tally	Frequency
0-1		
2-3		
4-5		
6-7		

Complete the cumulative frequency table below using these data.

Interval	Cumulative Frequency
0-1	
0-3	
0-5	
0-7	

On the grid below, create a cumulative frequency histogram based on the table you made.

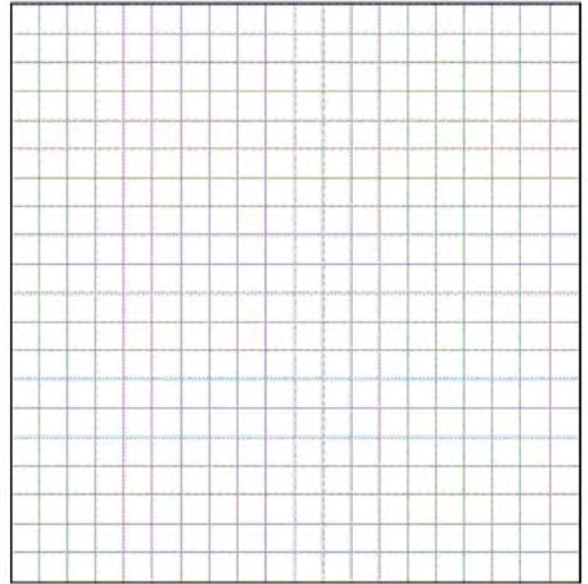

- 413 The diagram below shows right triangle UPC .

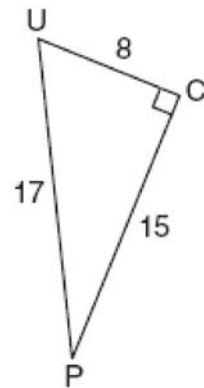

Which ratio represents the sine of $\angle U$?

- 1) $\frac{15}{8}$
- 2) $\frac{15}{17}$
- 3) $\frac{8}{15}$
- 4) $\frac{8}{17}$

Integrated Algebra Regents Exam Questions at Random

www.jmap.org

- 414 What is the value of x in the equation $\frac{2}{x} - 3 = \frac{26}{x}$?
- 1) -8
 - 2) $-\frac{1}{8}$
 - 3) $\frac{1}{8}$
 - 4) 8
- 415 Twelve players make up a high school basketball team. The team jerseys are numbered 1 through 12. The players wearing the jerseys numbered 3, 6, 7, 8, and 11 are the only players who start a game. Using set notation, list the complement of this subset.
- 416 Which expression represents $\frac{2x^2 - 12x}{x - 6}$ in simplest form?
- 1) 0
 - 2) $2x$
 - 3) $4x$
 - 4) $2x + 2$
- 417 Given:
 $A = \{\text{All even integers from 2 to 20, inclusive}\}$
 $B = \{10, 12, 14, 16, 18\}$
 What is the complement of set B within the universe of set A ?
- 1) $\{4, 6, 8\}$
 - 2) $\{2, 4, 6, 8\}$
 - 3) $\{4, 6, 8, 20\}$
 - 4) $\{2, 4, 6, 8, 20\}$
- 418 Tom drove 290 miles from his college to home and used 23.2 gallons of gasoline. His sister, Ann, drove 225 miles from her college to home and used 15 gallons of gasoline. Whose vehicle had better gas mileage? Justify your answer.
- 419 Which ordered pair is a solution to the system of equations $y = x$ and $y = x^2 - 2$?
- 1) $(-2, -2)$
 - 2) $(-1, 1)$
 - 3) $(0, 0)$
 - 4) $(2, 2)$
- 420 What is the value of the y -coordinate of the solution to the system of equations $x - 2y = 1$ and $x + 4y = 7$?
- 1) 1
 - 2) -1
 - 3) 3
 - 4) 4
- 421 Erica is conducting a survey about the proposed increase in the sports budget in the Hometown School District. Which survey method would likely contain the most bias?
- 1) Erica asks every third person entering the Hometown Grocery Store.
 - 2) Erica asks every third person leaving the Hometown Shopping Mall this weekend.
 - 3) Erica asks every fifth student entering Hometown High School on Monday morning.
 - 4) Erica asks every fifth person leaving Saturday's Hometown High School football game.

Integrated Algebra Regents Exam Questions at Random

www.jmap.org

- 422 Clayton has three fair coins. Find the probability that he gets two tails and one head when he flips the three coins.
- 423 The Hudson Record Store is having a going-out-of-business sale. CDs normally sell for \$18.00. During the first week of the sale, all CDs will sell for \$15.00. Written as a fraction, what is the rate of discount? What is this rate expressed as a percent? Round your answer to the *nearest hundredth of a percent*. During the second week of the sale, the same CDs will be on sale for 25% off the *original* price. What is the price of a CD during the second week of the sale?
- 424 Which ordered pair is a solution of the system of equations $y = x^2 - x - 20$ and $y = 3x - 15$?
- 1) $(-5, -30)$
 - 2) $(-1, -18)$
 - 3) $(0, 5)$
 - 4) $(5, -1)$
- 425 If the formula for the perimeter of a rectangle is $P = 2l + 2w$, then w can be expressed as
- 1) $w = \frac{2l - P}{2}$
 - 2) $w = \frac{P - 2l}{2}$
 - 3) $w = \frac{P - l}{2}$
 - 4) $w = \frac{P - 2w}{2l}$
- 426 Which ordered pair is in the solution set of the system of equations $y = -x + 1$ and $y = x^2 + 5x + 6$?
- 1) $(-5, -1)$
 - 2) $(-5, 6)$
 - 3) $(5, -4)$
 - 4) $(5, 2)$
- 427 What is $\frac{6}{4a} - \frac{2}{3a}$ expressed in simplest form?
- 1) $\frac{4}{a}$
 - 2) $\frac{5}{6a}$
 - 3) $\frac{8}{7a}$
 - 4) $\frac{10}{12a}$
- 428 An online music club has a one-time registration fee of \$13.95 and charges \$0.49 to buy each song. If Emma has \$50.00 to join the club and buy songs, what is the maximum number of songs she can buy?
- 1) 73
 - 2) 74
 - 3) 130
 - 4) 131
- 429 The set $\{1, 2, 3, 4\}$ is equivalent to
- 1) $\{x \mid 1 < x < 4, \text{ where } x \text{ is a whole number}\}$
 - 2) $\{x \mid 0 < x < 4, \text{ where } x \text{ is a whole number}\}$
 - 3) $\{x \mid 0 < x \leq 4, \text{ where } x \text{ is a whole number}\}$
 - 4) $\{x \mid 1 < x \leq 4, \text{ where } x \text{ is a whole number}\}$

- 430 A swim team member performs a dive from a 14-foot-high springboard. The parabola below shows the path of her dive.

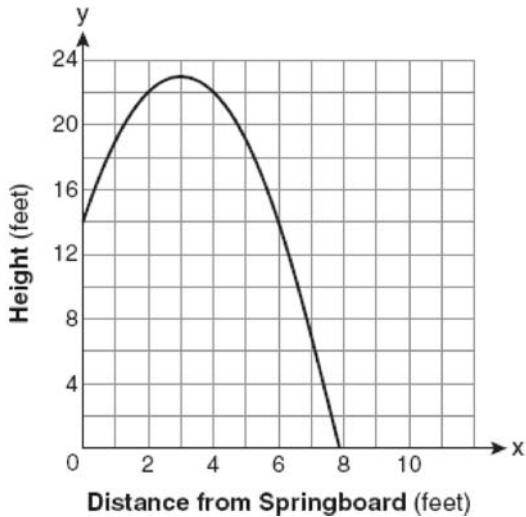

Which equation represents the axis of symmetry?

- 1) $x = 3$
 - 2) $y = 3$
 - 3) $x = 23$
 - 4) $y = 23$
- 431 If the speed of sound is 344 meters per second, what is the approximate speed of sound, in meters per hour?

60 seconds = 1 minute
 60 minutes = 1 hour

- 1) 20,640
- 2) 41,280
- 3) 123,840
- 4) 1,238,400

- 432 The cost of 3 markers and 2 pencils is \$1.80. The cost of 4 markers and 6 pencils is \$2.90. What is the cost of *each* item? Include appropriate units in your answer.

- 433 In the diagram of $\triangle ABC$ shown below, $BC = 10$ and $AB = 16$.

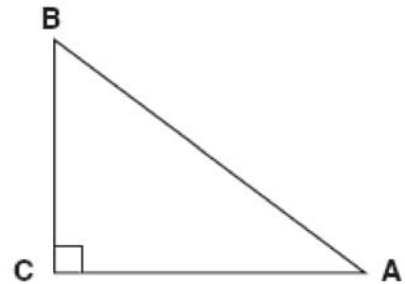

To the *nearest tenth of a degree*, what is the measure of the largest acute angle in the triangle?

- 1) 32.0
 - 2) 38.7
 - 3) 51.3
 - 4) 90.0
- 434 On a certain day in Toronto, Canada, the temperature was 15° Celsius (C). Using the formula $F = \frac{9}{5}C + 32$, Peter converts this temperature to degrees Fahrenheit (F). Which temperature represents 15°C in degrees Fahrenheit?
- 1) -9
 - 2) 35
 - 3) 59
 - 4) 85

- 435 A school wants to add a coed soccer program. To determine student interest in the program, a survey will be taken. In order to get an unbiased sample, which group should the school survey?
- 1) every third student entering the building
 - 2) every member of the varsity football team
 - 3) every member in Ms. Zimmer's drama classes
 - 4) every student having a second-period French class

- 436 Which situation should be analyzed using bivariate data?
- 1) Ms. Saleem keeps a list of the amount of time her daughter spends on her social studies homework.
 - 2) Mr. Benjamin tries to see if his students' shoe sizes are directly related to their heights.
 - 3) Mr. DeStefan records his customers' best video game scores during the summer.
 - 4) Mr. Chan keeps track of his daughter's algebra grades for the quarter.

- 437 Nancy's rectangular garden is represented in the diagram below.

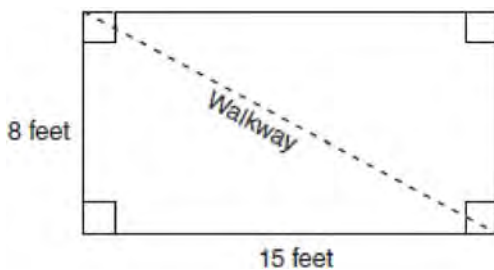

If a diagonal walkway crosses her garden, what is its length, in feet?

- 1) 17
- 2) 22
- 3) $\sqrt{161}$
- 4) $\sqrt{529}$

- 438 The number of hours spent on math homework each week and the final exam grades for twelve students in Mr. Dylan's algebra class are plotted below.

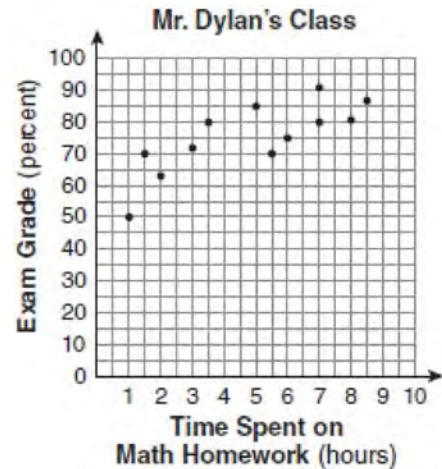

Based on a line of best fit, which exam grade is the best prediction for a student who spends about 4 hours on math homework each week?

- 1) 62
- 2) 72
- 3) 82
- 4) 92

- 439 Which value of x makes the expression $\frac{x+4}{x-3}$ undefined?

- 1) -4
- 2) -3
- 3) 3
- 4) 0

- 440 On the grid below, solve the system of equations graphically for x and y .

$$4x - 2y = 10$$

$$y = -2x - 1$$

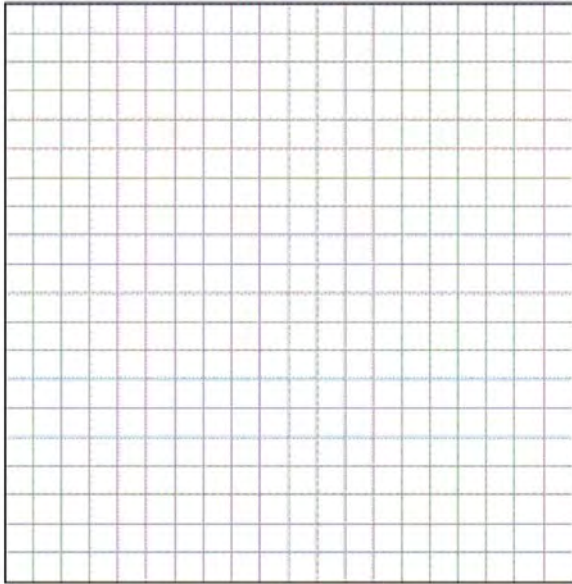

- 441 Which type of graph is shown in the diagram below?

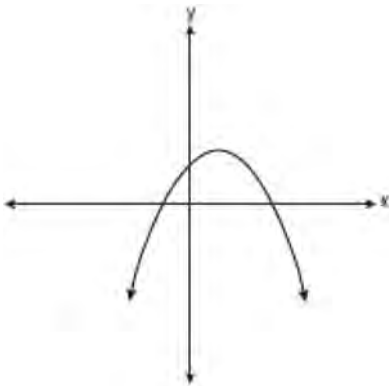

- 1) absolute value
- 2) exponential
- 3) linear
- 4) quadratic

- 442 Nicole's aerobics class exercises to fast-paced music. If the rate of the music is 120 beats per minute, how many beats would there be in a class that is 0.75 hour long?

- 1) 90
- 2) 160
- 3) 5,400
- 4) 7,200

- 443 Which value of x is in the solution set of

$$\frac{4}{3}x + 5 < 17?$$

- 1) 8
- 2) 9
- 3) 12
- 4) 16

- 444 What is the speed, in meters per second, of a paper airplane that flies 24 meters in 6 seconds?

- 1) 144
- 2) 30
- 3) 18
- 4) 4

- 445 Which value of p is the solution of $5p - 1 = 2p + 20$?

- 1) $\frac{19}{7}$
- 2) $\frac{19}{3}$
- 3) 3
- 4) 7

- 446 The length of the hypotenuse of a right triangle is 34 inches and the length of one of its legs is 16 inches. What is the length, in inches, of the other leg of this right triangle?
- 1) 16
 - 2) 18
 - 3) 25
 - 4) 30

- 447 In the diagram below, the circumference of circle O is 16π inches. The length of \overline{BC} is three-quarters of the length of diameter \overline{AD} and $CE = 4$ inches. Calculate the area, in square inches, of trapezoid $ABCD$.

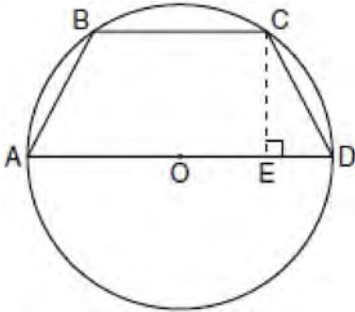

- 448 Cassandra bought an antique dresser for \$500. If the value of her dresser increases 6% annually, what will be the value of Cassandra's dresser at the end of 3 years to the nearest dollar?
- 1) \$415
 - 2) \$590
 - 3) \$596
 - 4) \$770

- 449 In triangle MCT , the measure of $\angle T = 90^\circ$, $MC = 85$ cm, $CT = 84$ cm, and $TM = 13$ cm. Which ratio represents the sine of $\angle C$?
- 1) $\frac{13}{85}$
 - 2) $\frac{84}{85}$
 - 3) $\frac{13}{84}$
 - 4) $\frac{84}{13}$

- 450 Which expression represents $\frac{x^2 - 2x - 15}{x^2 + 3x}$ in

simplest form?

- 1) -5
 - 2) $\frac{x-5}{x}$
 - 3) $\frac{-2x-5}{x}$
 - 4) $\frac{-2x-15}{3x}$
- 451 John is going to line up his four golf trophies on a shelf in his bedroom. How many different possible arrangements can he make?
- 1) 24
 - 2) 16
 - 3) 10
 - 4) 4
- 452 Solve for x : $\frac{x+1}{x} = \frac{-7}{x-12}$

- 453 Luis is going to paint a basketball court on his driveway, as shown in the diagram below. This basketball court consists of a rectangle and a semicircle.

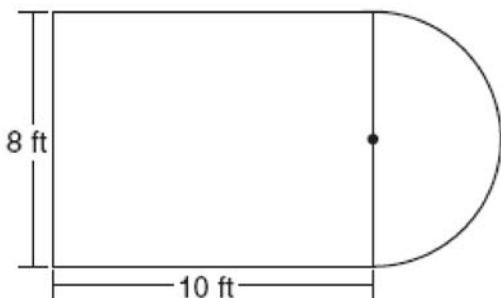

Which expression represents the area of this basketball court, in square feet?

- 1) 80
 - 2) $80 + 8\pi$
 - 3) $80 + 16\pi$
 - 4) $80 + 64\pi$
- 454 What is $\frac{6}{5x} - \frac{2}{3x}$ in simplest form?
- 1) $\frac{8}{15x^2}$
 - 2) $\frac{8}{15x}$
 - 3) $\frac{4}{15x}$
 - 4) $\frac{4}{2x}$
- 455 Which value of x is in the solution set of the inequality $-2x + 5 > 17$?
- 1) -8
 - 2) -6
 - 3) -4
 - 4) 12
- 456 Which expression represents $\frac{27x^{18}y^5}{9x^6y}$ in simplest form?
- 1) $3x^{12}y^4$
 - 2) $3x^3y^5$
 - 3) $18x^{12}y^4$
 - 4) $18x^3y^5$
- 457 Consider the graph of the equation $y = ax^2 + bx + c$, when $a \neq 0$. If a is multiplied by 3, what is true of the graph of the resulting parabola?
- 1) The vertex is 3 units above the vertex of the original parabola.
 - 2) The new parabola is 3 units to the right of the original parabola.
 - 3) The new parabola is wider than the original parabola.
 - 4) The new parabola is narrower than the original parabola.
- 458 Which value of x is the solution of the equation $\frac{2x}{3} + \frac{x}{6} = 5$?
- 1) 6
 - 2) 10
 - 3) 15
 - 4) 30
- 459 Factored, the expression $16x^2 - 25y^2$ is equivalent to
- 1) $(4x - 5y)(4x + 5y)$
 - 2) $(4x - 5y)(4x - 5y)$
 - 3) $(8x - 5y)(8x + 5y)$
 - 4) $(8x - 5y)(8x - 5y)$

460 What is an equation for the line that passes through the coordinates (2, 0) and (0, 3)?

- 1) $y = -\frac{3}{2}x + 3$
- 2) $y = -\frac{3}{2}x - 3$
- 3) $y = -\frac{2}{3}x + 2$
- 4) $y = -\frac{2}{3}x - 2$

461 Which equation could be used to find the measure of one acute angle in the right triangle shown below?

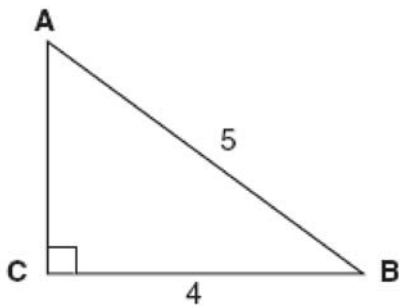

- 1) $\sin A = \frac{4}{5}$
- 2) $\tan A = \frac{5}{4}$
- 3) $\cos B = \frac{5}{4}$
- 4) $\tan B = \frac{4}{5}$

462 Which expression represents $(3x^2y^4)(4xy^2)$ in simplest form?

- 1) $12x^2y^8$
- 2) $12x^2y^6$
- 3) $12x^3y^8$
- 4) $12x^3y^6$

463 Which equation most closely represents the line of best fit for the scatter plot below?



- 1) $y = x$
- 2) $y = \frac{2}{3}x + 1$
- 3) $y = \frac{3}{2}x + 4$
- 4) $y = \frac{3}{2}x + 1$

- 464 Students in Ms. Nazzeer's mathematics class tossed a six-sided number cube whose faces are numbered 1 to 6. The results are recorded in the table below.

Result	Frequency
1	3
2	6
3	4
4	6
5	4
6	7

Based on these data, what is the empirical probability of tossing a 4?

- 1) $\frac{8}{30}$
 - 2) $\frac{6}{30}$
 - 3) $\frac{5}{30}$
 - 4) $\frac{1}{30}$
- 465 The function $y = \frac{x}{x^2 - 9}$ is undefined when the value of x is
- 1) 0 or 3
 - 2) 3 or -3
 - 3) 3, only
 - 4) -3 , only

- 466 The expression $\frac{9x^4 - 27x^6}{3x^3}$ is equivalent to
- 1) $3x(1 - 3x)$
 - 2) $3x(1 - 3x^2)$
 - 3) $3x(1 - 9x^5)$
 - 4) $9x^3(1 - x)$

- 467 The table below shows the number of prom tickets sold over a ten-day period.

Prom Ticket Sales

Day (x)	1	2	5	7	10
Number of Prom Tickets Sold (y)	30	35	55	60	70

Plot these data points on the coordinate grid below. Use a consistent and appropriate scale. Draw a reasonable line of best fit and write its equation.

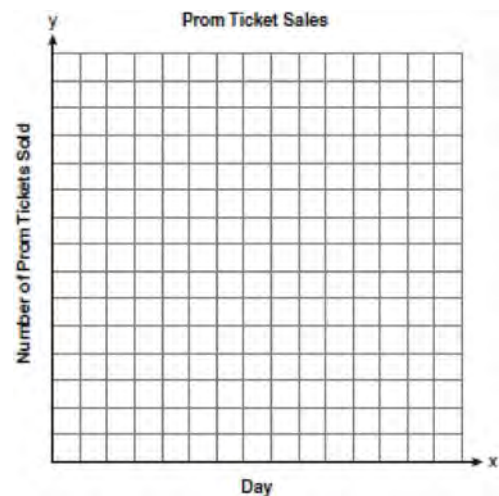

Integrated Algebra Regents at Random

- 468 The bull's-eye of a dartboard has a radius of 2 inches and the entire board has a radius of 9 inches, as shown in the diagram below.

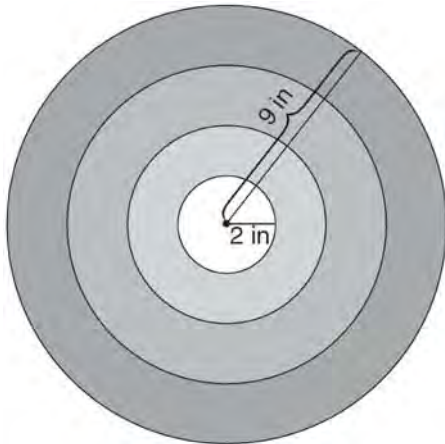

If a dart is thrown and hits the board, what is the probability that the dart will land in the bull's-eye?

- 1) $\frac{2}{9}$
2) $\frac{7}{9}$
3) $\frac{4}{81}$
4) $\frac{49}{81}$
- 469 A bank is advertising that new customers can open a savings account with a $3\frac{3}{4}\%$ interest rate compounded annually. Robert invests \$5,000 in an account at this rate. If he makes no additional deposits or withdrawals on his account, find the amount of money he will have, to the *nearest cent*, after three years.
- 470 The graph of a parabola is represented by the equation $y = ax^2$ where a is a positive integer. If a is multiplied by 2, the new parabola will become
1) narrower and open downward
2) narrower and open upward
3) wider and open downward
4) wider and open upward
- 471 Factored completely, the expression $3x^3 - 33x^2 + 90x$ is equivalent to
1) $3x(x^2 - 33x + 90)$
2) $3x(x^2 - 11x + 30)$
3) $3x(x + 5)(x + 6)$
4) $3x(x - 5)(x - 6)$
- 472 What is the solution of $\frac{2}{x+1} = \frac{x+1}{2}$?
1) -1 and -3
2) -1 and 3
3) 1 and -3
4) 1 and 3
- 473 The total score in a football game was 72 points. The winning team scored 12 points more than the losing team. How many points did the winning team score?
1) 30
2) 42
3) 54
4) 60

474 The product of $\frac{4x^2}{7y^2}$ and $\frac{21y^3}{20x^4}$, expressed in simplest form, is

- 1) $0.6x^2y$
- 2) $\frac{3y}{5x^2}$
- 3) $\frac{12x^2y^3}{20x^4y^2}$
- 4) $\frac{84x^2y^3}{140x^4y^2}$

475 On the set of axes below, graph the following system of equations. Using the graph, determine and state *all* solutions of the system of equations.

$$y = -x^2 - 2x + 3$$

$$y + 1 = -2x$$

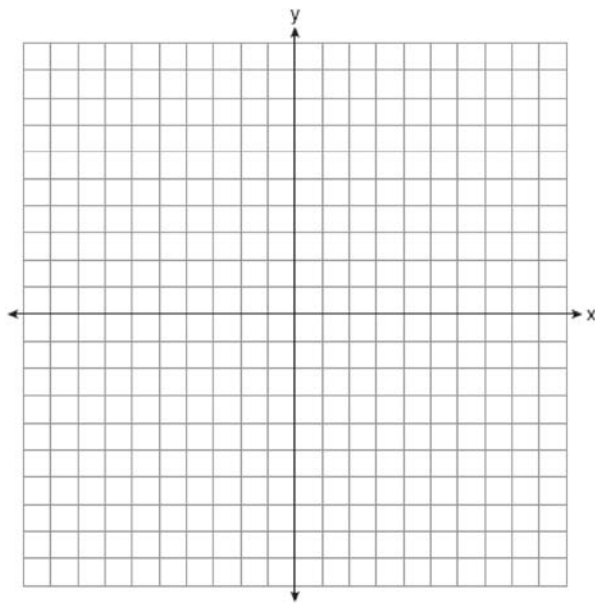

476 The scatter plot below shows the profit, by month, for a new company for the first year of operation. Kate drew a line of best fit, as shown in the diagram.

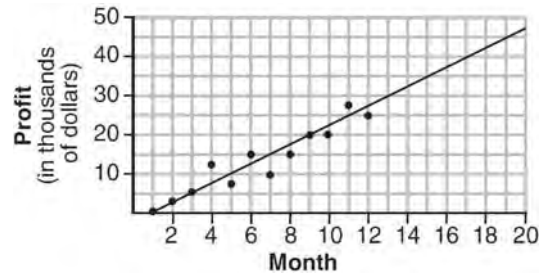

Using this line, what is the best estimate for profit in the 18th month?

- 1) \$35,000
- 2) \$37,750
- 3) \$42,500
- 4) \$45,000

477 Two equations were graphed on the set of axes below.

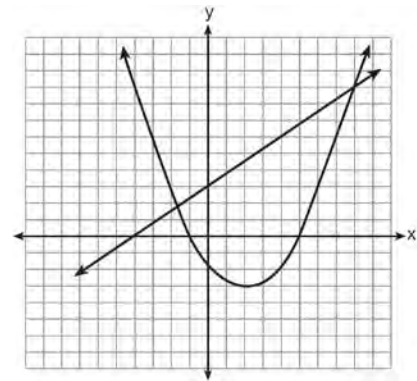

Which point is a solution of the system of equations shown on the graph?

- 1) (8, 9)
- 2) (5, 0)
- 3) (0, 3)
- 4) (2, -3)

- 478 Solve the following system of equations algebraically for *all* values of x and y .

$$y = x^2 + 2x - 8$$

$$y = 2x + 1$$

- 479 Which graph represents a function?

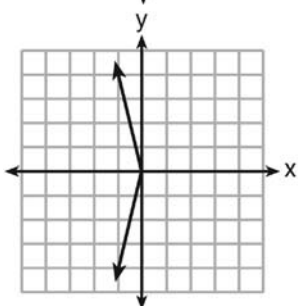
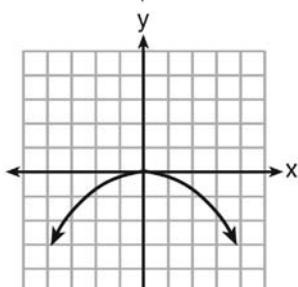
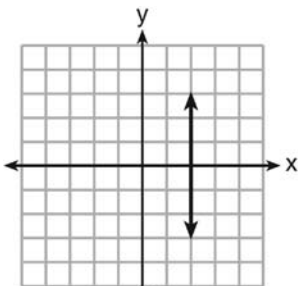
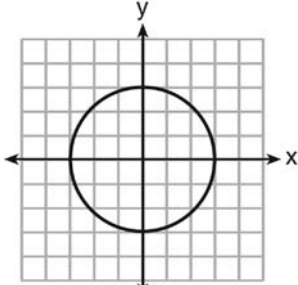

- 480 Brianna's score on a national math assessment exceeded the scores of 95,000 of the 125,000 students who took the assessment. What was her percentile rank?

- 1) 6
- 2) 24
- 3) 31
- 4) 76

- 481 If the volume of a cube is 8 cubic centimeters, what is its surface area, in square centimeters?

- 1) 32
- 2) 24
- 3) 12
- 4) 4

- 482 The current population of a town is 10,000. If the population, P , increases by 20% each year, which equation could be used to find the population after t years?

- 1) $P = 10,000(0.2)^t$
- 2) $P = 10,000(0.8)^t$
- 3) $P = 10,000(1.2)^t$
- 4) $P = 10,000(1.8)^t$

- 483 Three storage bins contain colored blocks. Bin 1 contains 15 red and 14 blue blocks. Bin 2 contains 16 white and 15 blue blocks. Bin 3 contains 15 red and 15 white blocks. All of the blocks from the three bins are placed into one box. If one block is randomly selected from the box, which color block would most likely be picked? Justify your answer.

- 484 The menu for the high school cafeteria is shown below.

Main Course	Vegetable	Dessert	Beverage
veggie burger	corn	gelatin	milk
pizza	green beans	fruit salad	juice
tuna sandwich	carrots	yogurt	bottled water
frankfurter		cookie	
chicken tenders		ice cream cup	

Determine the number of possible meals consisting of a main course, a vegetable, a dessert, and a beverage that can be selected from the menu. Determine how many of these meals will include chicken tenders. If a student chooses pizza, corn or carrots, a dessert, and a beverage from the menu, determine the number of possible meals that can be selected.

- 485 A metal pipe is used to hold up a 9-foot fence, as shown in the diagram below. The pipe makes an angle of 48° with the ground.

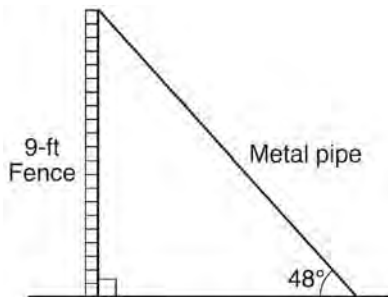

Determine, to the *nearest foot*, how far the bottom of the pipe is from the base of the fence. Determine, to the *nearest foot*, the length of the metal pipe.

- 486 Given: $R = \{1, 2, 3, 4\}$
 $A = \{0, 2, 4, 6\}$
 $P = \{1, 3, 5, 7\}$

What is $R \cap P$?

- 1) $\{0, 1, 2, 3, 4, 5, 6, 7\}$
 - 2) $\{1, 2, 3, 4, 5, 7\}$
 - 3) $\{1, 3\}$
 - 4) $\{2, 4\}$
- 487 Which equation represents a line that is parallel to the line whose equation is $2x - 3y = 9$?
- 1) $y = \frac{2}{3}x - 4$
 - 2) $y = -\frac{2}{3}x + 4$
 - 3) $y = \frac{3}{2}x - 4$
 - 4) $y = -\frac{3}{2}x + 4$
- 488 Noj is 5 years older than Jacob. The product of their ages is 84. How old is Noj?
- 1) 6
 - 2) 7
 - 3) 12
 - 4) 14

- 489 The statement $|-15| < x < |-20|$ is true when x is equal to
- 1) -16
 - 2) -14
 - 3) 17
 - 4) 21

490 Which is the equation of a parabola that has the same vertex as the parabola represented by $y = x^2$, but is wider?

- 1) $y = x^2 + 2$
- 2) $y = x^2 - 2$
- 3) $y = 2x^2$
- 4) $y = \frac{1}{2}x^2$

491 A jogger ran at a rate of 5.4 miles per hour. Find the jogger's *exact* rate, in feet per minute.

1 mile = 5,280 feet

492 Which set of coordinates is a solution of the equation $2x - y = 11$?

- 1) $(-6, 1)$
- 2) $(-1, 9)$
- 3) $(0, 11)$
- 4) $(2, -7)$

493 Gabriella has 20 quarters, 15 dimes, 7 nickels, and 8 pennies in a jar. After taking 6 quarters out of the jar, what will be the probability of Gabriella randomly selecting a quarter from the coins left in the jar?

- 1) $\frac{14}{44}$
- 2) $\frac{30}{44}$
- 3) $\frac{14}{50}$
- 4) $\frac{20}{50}$

494 A large company must chose between two types of passwords to log on to a computer. The first type is a four-letter password using any of the 26 letters of the alphabet, without repetition of letters. The second type is a six-digit password using the digits 0 through 9, with repetition of digits allowed. Determine the number of possible four-letter passwords. Determine the number of possible six-digit passwords. The company has 500,000 employees and needs a different password for each employee. State which type of password the company should choose. Explain your answer.

495 On the set of axes below, solve the following system of equations graphically. State the coordinates of the solution.

$$y = 4x - 1$$

$$2x + y = 5$$

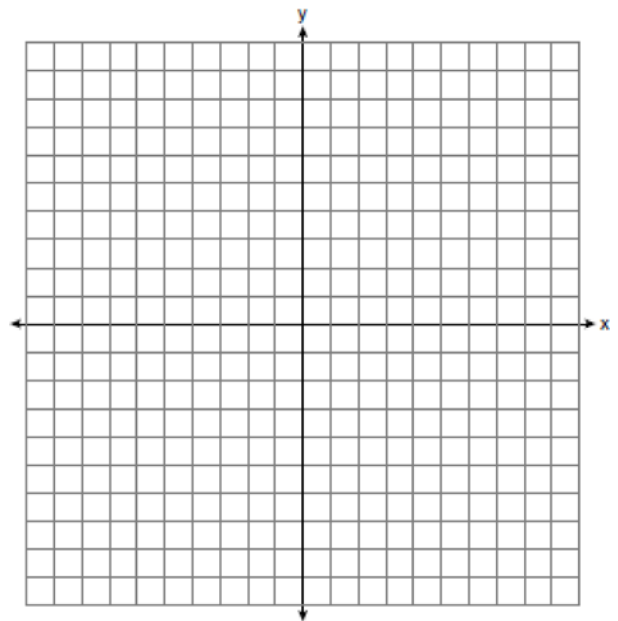

496 Which table shows bivariate data?

1)

Age (yr)	Frequency
14	12
15	21
16	14
17	19
18	15

2)

Type of Car	Average Gas Mileage (mpg)
van	25
SUV	23
luxury	26
compact	28
pickup	22

3)

Time Spent Studying (hr)	Test Grade (%)
1	65
2	72
3	83
4	85
5	92

4)

Day	Temperature (degrees F)
Monday	63
Tuesday	58
Wednesday	72
Thursday	74
Friday	78

497 There are 18 students in a class. Each day, the teacher randomly selects three students to assist in a game: a leader, a recorder, and a timekeeper. In how many possible ways can the jobs be assigned?

- 1) 306
- 2) 816
- 3) 4896
- 4) 5832

498 A survey is being conducted to determine if a cable company should add another sports channel to their schedule. Which random survey would be the least biased?

- 1) surveying 30 men at a gym
- 2) surveying 45 people at a mall
- 3) surveying 50 fans at a football game
- 4) surveying 20 members of a high school soccer team

499 The following cumulative frequency histogram shows the distances swimmers completed in a recent swim test.

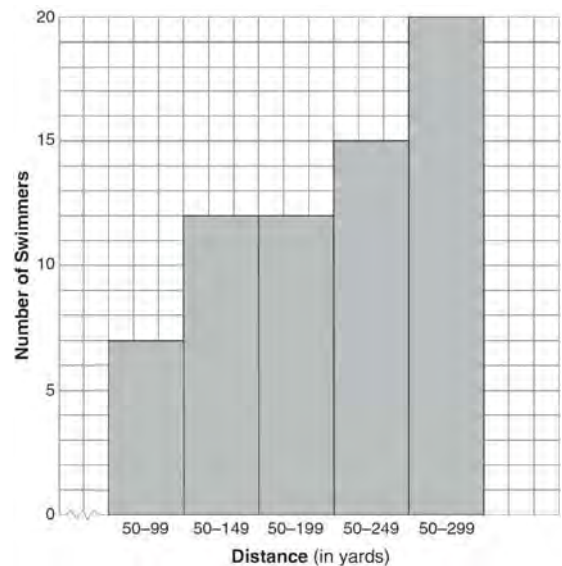

Based on the cumulative frequency histogram, determine the number of swimmers who swam between 200 and 249 yards. Determine the number of swimmers who swam between 150 and 199 yards. Determine the number of swimmers who took the swim test.

Integrated Algebra Regents Exam Questions at Random
www.jmap.org

500 If five times a number is less than 55, what is the greatest possible integer value of the number?

- 1) 12
- 2) 11
- 3) 10
- 4) 9

501 Which expression is equivalent to $64 - x^2$?

- 1) $(8 - x)(8 - x)$
- 2) $(8 - x)(8 + x)$
- 3) $(x - 8)(x - 8)$
- 4) $(x - 8)(x + 8)$

502 In a baseball game, the ball traveled 350.7 feet in 4.2 seconds. What was the average speed of the ball, in feet per second?

- 1) 83.5
- 2) 177.5
- 3) 354.9
- 4) 1,472.9

503 The graph of $y = |x + 2|$ is shown below.

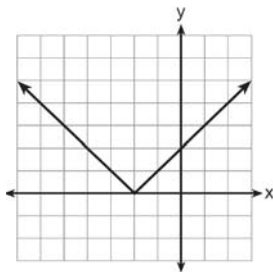

Which graph represents $y = -|x + 2|$?

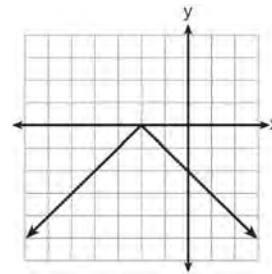
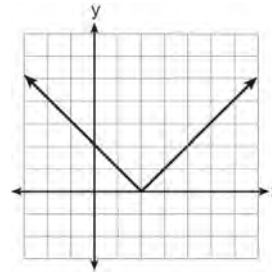
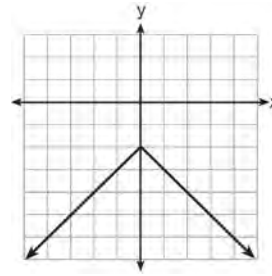
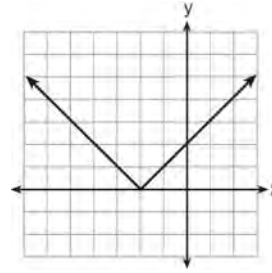

504 What is $24x^2y^6 - 16x^6y^2 + 4xy^2$ divided by $4xy^2$?

- 1) $6xy^4 - 4x^5$
- 2) $6xy^4 - 4x^5 + 1$
- 3) $6x^2y^3 - 4x^6y$
- 4) $6x^2y^3 - 4x^6y + 1$

- 505 The actual dimensions of a rectangle are 2.6 cm by 6.9 cm. Andy measures the sides as 2.5 cm by 6.8 cm. In calculating the area, what is the relative error, to the *nearest thousandth*?
- 1) 0.055
 - 2) 0.052
 - 3) 0.022
 - 4) 0.021

- 506 How is the graph of $y = x^2 + 4x + 3$ affected when the coefficient of x^2 is changed to a smaller positive number?
- 1) The graph becomes wider, and the y -intercept changes.
 - 2) The graph becomes wider, and the y -intercept stays the same.
 - 3) The graph becomes narrower, and the y -intercept changes.
 - 4) The graph becomes narrower, and the y -intercept stays the same.

- 507 Solve the following system of equations algebraically for y :

$$2x + 2y = 9$$

$$2x - y = 3$$

- 508 The quotient of $\frac{8x^5 - 2x^4 + 4x^3 - 6x^2}{2x^2}$ is
- 1) $16x^7 - 4x^6 + 8x^5 - 12x^4$
 - 2) $4x^7 - x^6 + 2x^5 - 3x^4$
 - 3) $4x^3 - x^2 + 2x - 3x$
 - 4) $4x^3 - x^2 + 2x - 3$

- 509 On the set of axes below, graph the following system of inequalities.

$$y + x \geq 3$$

$$5x - 2y > 10$$

State the coordinates of *one* point that satisfies $y + x \geq 3$, but does *not* satisfy $5x - 2y > 10$.

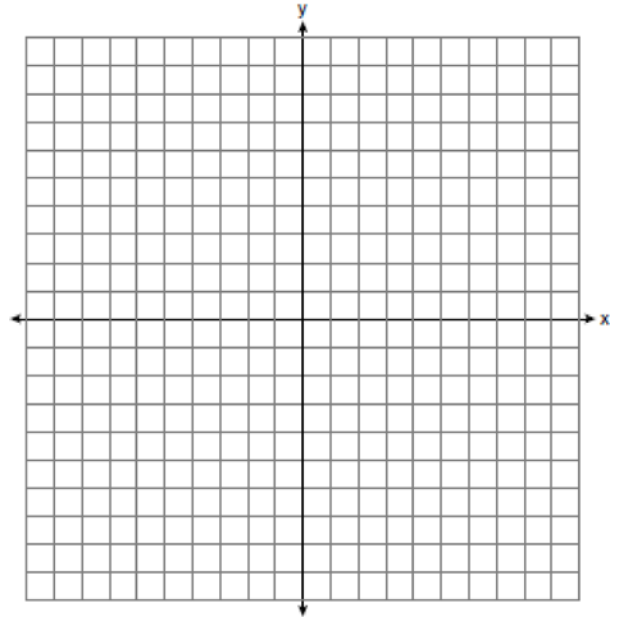

- 510 The solution of the equation $5 - 2x = -4x - 7$ is
- 1) 1
 - 2) 2
 - 3) -2
 - 4) -6

- 511 A cube, with faces numbered 1 to 6, is rolled, and a penny is tossed at the same time. How many elements in the sample space consist of an even number and a tail?
- 1) 12
 - 2) 2
 - 3) 3
 - 4) 4

Integrated Algebra Regents Exam Questions at Random

www.jmap.org

512 Casey purchased a pack of assorted flower seeds and planted them in her garden. When the first 25 flowers bloomed, 11 were white, 5 were red, 3 were blue, and the rest were yellow. Find the empirical probability that a flower that blooms will be yellow.

513 A 28-foot ladder is leaning against a house. The bottom of the ladder is 6 feet from the base of the house. Find the measure of the angle formed by the ladder and the ground, to the *nearest degree*.

514 Which coordinates represent a point in the solution set of the system of inequalities shown below?

$$y \leq \frac{1}{2}x + 13$$

$$4x + 2y > 3$$

- 1) $(-4, 1)$
- 2) $(-2, 2)$
- 3) $(1, -4)$
- 4) $(2, -2)$

515 The roots of the equation $x^2 - 14x + 48 = 0$ are

- 1) -6 and -8
- 2) -6 and 8
- 3) 6 and -8
- 4) 6 and 8

516 The value of the expression $6! + \frac{5!(3!)}{4!} - 10$ is

- 1) 50
- 2) 102
- 3) 740
- 4) 750

517 The line represented by the equation $2y - 3x = 4$ has a slope of

- 1) $-\frac{3}{2}$
- 2) 2
- 3) 3
- 4) $\frac{3}{2}$

518 Which situation describes a negative correlation?

- 1) the amount of gas left in a car's tank and the amount of gas used from it
- 2) the number of gallons of gas purchased and the amount paid for the gas
- 3) the size of a car's gas tank and the number of gallons it holds
- 4) the number of miles driven and the amount of gas used

519 Express $\frac{3\sqrt{75} + \sqrt{27}}{3}$ in simplest radical form.

520 A bag contains five green gumdrops and six red gumdrops. If Kim pulls a green gumdrop out of the bag and eats it, what is the probability that the next gumdrop she pulls out will be red?

- 1) $\frac{5}{11}$
- 2) $\frac{5}{10}$
- 3) $\frac{6}{11}$
- 4) $\frac{6}{10}$

- 521 The expression $9a^2 - 64b^2$ is equivalent to
- 1) $(9a - 8b)(a + 8b)$
 - 2) $(9a - 8b)(a - 8b)$
 - 3) $(3a - 8b)(3a + 8b)$
 - 4) $(3a - 8b)(3a - 8b)$

- 522 Which value of x is the solution of the equation

$$\frac{1}{7} + \frac{2x}{3} = \frac{15x - 3}{21} ?$$

- 1) 6
- 2) 0
- 3) $\frac{4}{13}$
- 4) $\frac{6}{29}$

- 523 Solve algebraically for x :
 $3(x + 1) - 5x = 12 - (6x - 7)$

- 524 Monique has three sons who play football, two sons who play baseball, and one son who plays both sports. If all of her sons play baseball or football, how many sons does she have?
- 1) 5
 - 2) 6
 - 3) 3
 - 4) 4

- 525 The sum of three consecutive odd integers is 18 less than five times the middle number. Find the three integers. [Only an algebraic solution can receive full credit.]

- 526 On the set of axes below, graph $y = 2|x + 3|$. Include the interval $-7 \leq x \leq 1$.

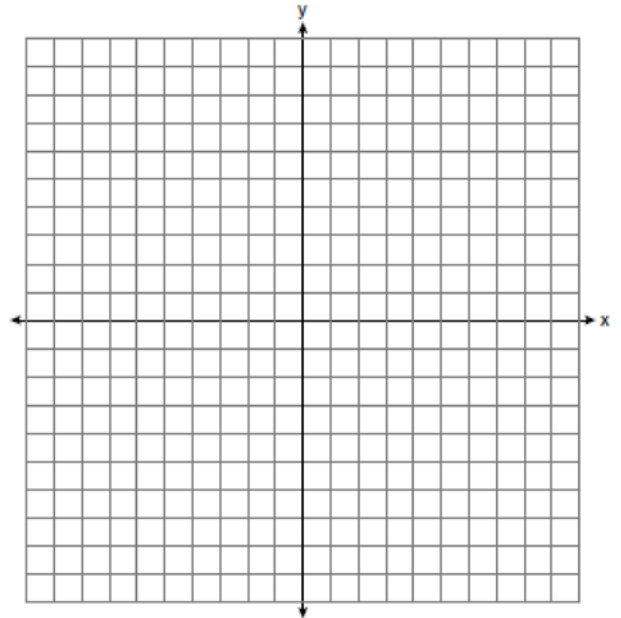

- 527 A cube with faces numbered 1 through 6 is rolled 75 times, and the results are given in the table below.

Number	Frequency
1	7
2	22
3	14
4	6
5	20
6	6

Based on these results, which statement is true?

- 1) $P(\text{odd}) < P(\text{even})$
- 2) $P(3 \text{ or less}) < P(\text{odd})$
- 3) $P(\text{even}) < P(2 \text{ or } 4)$
- 4) $P(2 \text{ or } 4) < P(3 \text{ or less})$

528 Which graph represents the inequality $y \geq x + 3$?

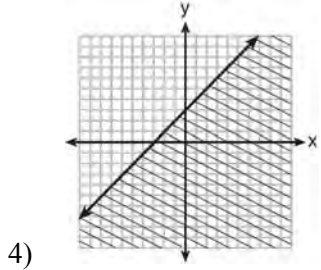
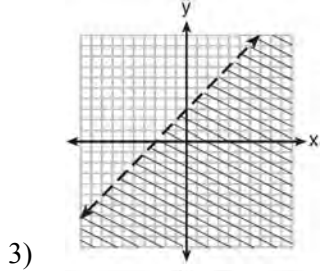
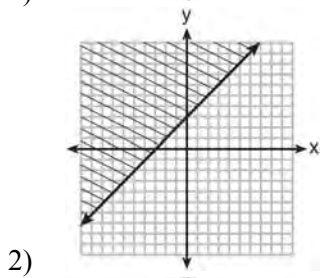
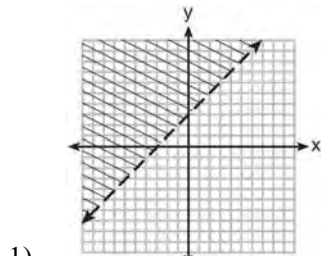

529 A correct translation of “six less than twice the value of x ” is

- 1) $2x < 6$
- 2) $2x - 6$
- 3) $6 < 2x$
- 4) $6 - 2x$

530 Solve algebraically: $\frac{2}{3x} + \frac{4}{x} = \frac{7}{x+1}$

[Only an algebraic solution can receive full credit.]

531 If the area of a rectangle is represented by $x^2 + 8x + 15$ and its length is represented by $x + 5$, which expression represents the width of the rectangle?

- 1) $x + 3$
- 2) $x - 3$
- 3) $x^2 + 6x + 5$
- 4) $x^2 + 7x + 10$

532 What is the solution set of the system of equations $x + y = 5$ and $y = x^2 - 25$?

- 1) $\{(0, 5), (11, -6)\}$
- 2) $\{(5, 0), (-6, 11)\}$
- 3) $\{(-5, 0), (6, 11)\}$
- 4) $\{(-5, 10), (6, -1)\}$

533 If $k = am + 3mx$, the value of m in terms of a , k , and x can be expressed as

- 1) $\frac{k}{a + 3x}$
- 2) $\frac{k - 3mx}{a}$
- 3) $\frac{k - am}{3x}$
- 4) $\frac{k - a}{3x}$

- 534 A designer created a garden, as shown in the diagram below. The garden consists of four quarter-circles of equal size inside a square. The designer put a fence around both the inside and the outside of the garden.

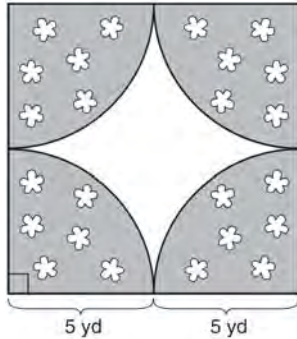

Which expression represents the amount of fencing, in yards, that the designer used for the fence?

- 1) $40 + 10\pi$
 2) $40 + 25\pi$
 3) $100 + 10\pi$
 4) $100 + 25\pi$
- 535 What is the value of $\left| \frac{4(-6) + 18}{4!} \right|$?
- 1) $\frac{1}{4}$
 2) $-\frac{1}{4}$
 3) 12
 4) -12
- 536 The sum of $3x^2 + 5x - 6$ and $-x^2 + 3x + 9$ is
- 1) $2x^2 + 8x - 15$
 2) $2x^2 + 8x + 3$
 3) $2x^4 + 8x^2 + 3$
 4) $4x^2 + 2x - 15$

- 537 Elizabeth is baking chocolate chip cookies. A single batch uses $\frac{3}{4}$ teaspoon of vanilla. If Elizabeth is mixing the ingredients for five batches at the same time, how many tablespoons of vanilla will she use?

$3 \text{ teaspoons} = 1 \text{ tablespoon}$
--

- 1) $1\frac{1}{4}$
 2) $1\frac{3}{4}$
 3) $3\frac{3}{4}$
 4) $5\frac{3}{4}$
- 538 The equation of the axis of symmetry of the graph of $y = 2x^2 - 3x + 7$ is
- 1) $x = \frac{3}{4}$
 2) $y = \frac{3}{4}$
 3) $x = \frac{3}{2}$
 4) $y = \frac{3}{2}$
- 539 The expression $100n^2 - 1$ is equivalent to
- 1) $(10n + 1)(10n - 1)$
 2) $(10n - 1)(10n - 1)$
 3) $(50n + 1)(50n - 1)$
 4) $(50n - 1)(50n - 1)$

- 540 What is the solution of the system of equations shown in the graph below?

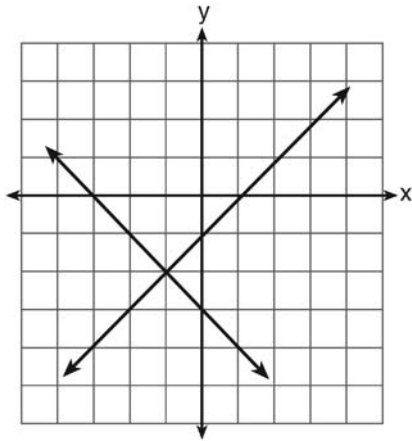

- 1) $(1, 0)$ and $(-3, 0)$
 - 2) $(0, -3)$ and $(0, -1)$
 - 3) $(-1, -2)$
 - 4) $(-2, -1)$
- 541 Which equation represents a line that is parallel to the y -axis and passes through the point $(4, 3)$?

- 1) $x = 3$
- 2) $x = 4$
- 3) $y = 3$
- 4) $y = 4$

- 542 Wendy measures the floor in her rectangular bedroom for new carpeting. Her measurements are 24 feet by 14 feet. The actual measurements are 24.2 feet by 14.1 feet. Determine the relative error in calculating the area of her bedroom. Express your answer as a decimal to the *nearest thousandth*.

- 543 The cost of three notebooks and four pencils is \$8.50. The cost of five notebooks and eight pencils is \$14.50. Determine the cost of one notebook and the cost of one pencil. [Only an algebraic solution can receive full credit.]

- 544 A system of equations is graphed on the set of axes below.

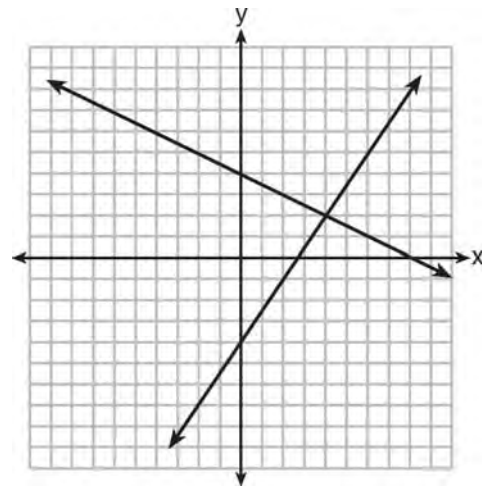

The solution of this system is

- 1) $(0, 4)$
 - 2) $(2, 4)$
 - 3) $(4, 2)$
 - 4) $(8, 0)$
- 545 When $8x^2 + 3x + 2$ is subtracted from $9x^2 - 3x - 4$, the result is
- 1) $x^2 - 2$
 - 2) $17x^2 - 2$
 - 3) $-x^2 + 6x + 6$
 - 4) $x^2 - 6x - 6$

- 546 Mike buys his ice cream packed in a rectangular prism-shaped carton, while Carol buys hers in a cylindrical-shaped carton. The dimensions of the prism are 5 inches by 3.5 inches by 7 inches. The cylinder has a diameter of 5 inches and a height of 7 inches. Which container holds more ice cream? Justify your answer. Determine, to the *nearest tenth of a cubic inch*, how much more ice cream the larger container holds.
- 547 Which expression can be used to change 75 kilometers per hour to meters per minute?
- 1) $\frac{75 \text{ km}}{1 \text{ hr}} \times \frac{1 \text{ km}}{1,000 \text{ m}} \times \frac{1 \text{ hr}}{60 \text{ min}}$
 - 2) $\frac{75 \text{ km}}{1 \text{ hr}} \times \frac{1 \text{ km}}{1,000 \text{ m}} \times \frac{60 \text{ min}}{1 \text{ hr}}$
 - 3) $\frac{75 \text{ km}}{1 \text{ hr}} \times \frac{1,000 \text{ m}}{1 \text{ km}} \times \frac{1 \text{ hr}}{60 \text{ min}}$
 - 4) $\frac{75 \text{ km}}{1 \text{ hr}} \times \frac{1,000 \text{ m}}{1 \text{ km}} \times \frac{60 \text{ min}}{1 \text{ hr}}$
- 548 Craig sees an advertisement for a car in a newspaper. Which information would *not* be classified as quantitative?
- 1) the cost of the car
 - 2) the car's mileage
 - 3) the model of the car
 - 4) the weight of the car
- 549 How many cubes with 5-inch sides will completely fill a cube that is 10 inches on a side?
- 1) 50
 - 2) 25
 - 3) 8
 - 4) 4
- 550 Which situation is an example of bivariate data?
- 1) the number of pizzas Tanya eats during her years in high school
 - 2) the number of times Ezra puts air in his bicycle tires during the summer
 - 3) the number of home runs Elias hits per game and the number of hours he practices baseball
 - 4) the number of hours Nellie studies for her mathematics tests during the first half of the school year
- 551 A cell phone can receive 120 messages per minute. At this rate, how many messages can the phone receive in 150 seconds?
- 1) 48
 - 2) 75
 - 3) 300
 - 4) 18,000
- 552 Students calculated the area of a playing field to be 8,100 square feet. The actual area of the field is 7,678.5 square feet. Find the relative error in the area, to the *nearest thousandth*.
- 553 Which equation represents a line that is parallel to the line whose equation is $y = -3x - 7$?
- 1) $y = -3x + 4$
 - 2) $y = -\frac{1}{3}x - 7$
 - 3) $y = \frac{1}{3}x + 5$
 - 4) $y = 3x - 2$

554 Which graph represents a function?

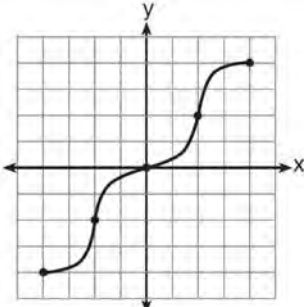

1)

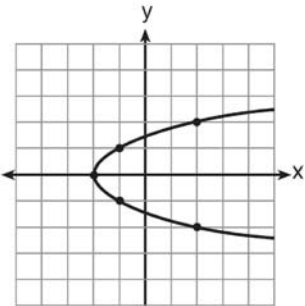

2)

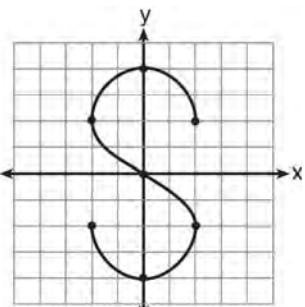

3)

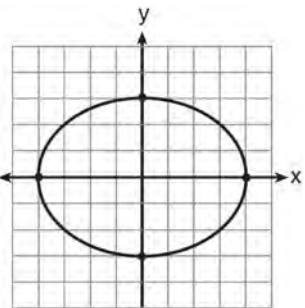

4)

555 When $2x^2 - 3x + 2$ is subtracted from $4x^2 - 5x + 2$, the result is

- 1) $2x^2 - 2x$
- 2) $-2x^2 + 2x$
- 3) $-2x^2 - 8x + 4$
- 4) $2x^2 - 8x + 4$

556 The expression $\frac{x-3}{x+2}$ is undefined when the value of x is

- 1) -2 , only
- 2) -2 and 3
- 3) 3 , only
- 4) -3 and 2

557 What is the perimeter of the figure shown below, which consists of an isosceles trapezoid and a semicircle?

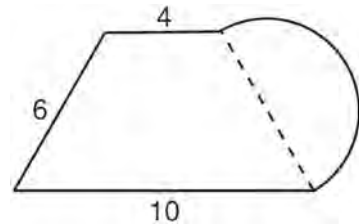

- 1) $20 + 3\pi$
- 2) $20 + 6\pi$
- 3) $26 + 3\pi$
- 4) $26 + 6\pi$

558 Express $4\sqrt{75}$ in simplest radical form.

- 559 The expression $\frac{(4x^3)^2}{2x}$ is equivalent to
- 1) $4x^4$
 - 2) $4x^5$
 - 3) $8x^4$
 - 4) $8x^5$

- 560 The box-and-whisker plot below represents a set of grades in a college statistics class.

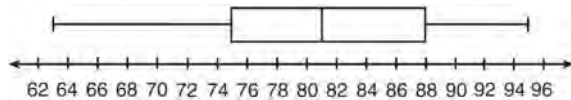

Which interval contains exactly 50% of the grades?

- 1) 63-88
 - 2) 63-95
 - 3) 75-81
 - 4) 75-88
- 561 A bottle contains 12 red marbles and 8 blue marbles. A marble is chosen at random and not replaced. Then, a second marble is chosen at random. Determine the probability that the two marbles are *not* the same color. Determine the probability that *at least* one of the marbles is red.
- 562 In right triangle ABC , $m\angle C = 90^\circ$, $\overline{AC} = 7$, and $\overline{AB} = 13$. What is the length of \overline{BC} ?
- 1) 6
 - 2) 20
 - 3) $\sqrt{120}$
 - 4) $\sqrt{218}$

- 563 In the figure below, $ABCD$ is a square and semicircle O has a radius of 6.

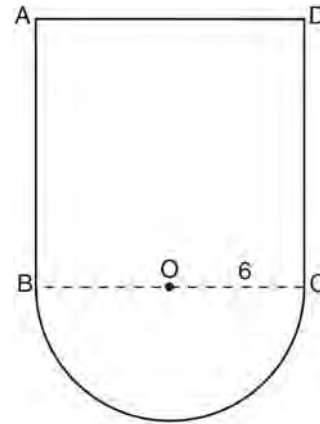

What is the area of the figure?

- 1) $36 + 6\pi$
 - 2) $36 + 18\pi$
 - 3) $144 + 18\pi$
 - 4) $144 + 36\pi$
- 564 The probability it will rain tomorrow is $\frac{1}{2}$. The probability that our team will win tomorrow's basketball game is $\frac{3}{5}$. Which expression represents the probability that it will rain and that our team will *not* win the game?
- 1) $\frac{1}{2} + \frac{3}{5}$
 - 2) $\frac{1}{2} + \frac{2}{5}$
 - 3) $\frac{1}{2} \times \frac{3}{5}$
 - 4) $\frac{1}{2} \times \frac{2}{5}$

565 A man standing on level ground is 1000 feet away from the base of a 350-foot-tall building. Find, to the *nearest degree*, the measure of the angle of elevation to the top of the building from the point on the ground where the man is standing.

566 In the diagram below of rectangle $AFEB$ and a semicircle with diameter CD , $AB = 5$ inches, $AB = BC = DE = FE$, and $CD = 6$ inches. Find the area of the shaded region, to the *nearest hundredth of a square inch*.

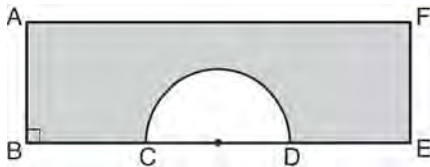

567 Mr. Taylor raised all his students' scores on a recent test by five points. How were the mean and the range of the scores affected?

- 1) The mean increased by five and the range increased by five.
- 2) The mean increased by five and the range remained the same.
- 3) The mean remained the same and the range increased by five.
- 4) The mean remained the same and the range remained the same.

568 Which statement illustrates the additive identity property?

- 1) $6 + 0 = 6$
- 2) $-6 + 6 = 0$
- 3) $4(6 + 3) = 4(6) + 4(3)$
- 4) $(4 + 6) + 3 = 4 + (6 + 3)$

569 On the set of axes below, graph $y = 3^x$ over the interval $-1 \leq x \leq 2$.

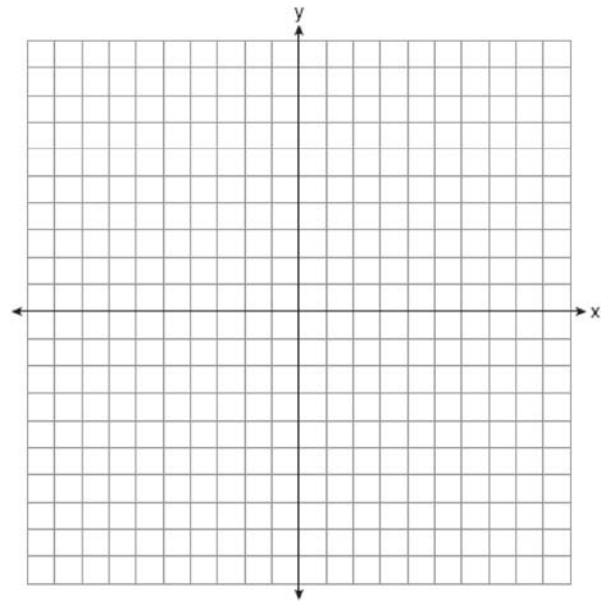

570 If Angelina's weekly allowance is d dollars, which expression represents her allowance, in dollars, for x weeks?

- 1) dx
- 2) $7dx$
- 3) $x + 7d$
- 4) $\frac{d}{x}$

571 An art studio has a list of information posted with each sculpture that is for sale. Each entry in the list could be classified as quantitative *except* for the

- 1) cost
- 2) height
- 3) artist
- 4) weight

- 572 What is the vertex of the parabola represented by the equation $y = -2x^2 + 24x - 100$?
- 1) $x = -6$
 - 2) $x = 6$
 - 3) $(6, -28)$
 - 4) $(-6, -316)$
- 573 The difference between two numbers is 28. The larger number is 8 less than twice the smaller number. Find *both* numbers. [Only an algebraic solution can receive full credit.]
- 574 The formula for the volume of a pyramid is $V = \frac{1}{3}Bh$. What is h expressed in terms of B and V ?
- 1) $h = \frac{1}{3}VB$
 - 2) $h = \frac{V}{3B}$
 - 3) $h = \frac{3V}{B}$
 - 4) $h = 3VB$
- 575 A car depreciates (loses value) at a rate of 4.5% annually. Greg purchased a car for \$12,500. Which equation can be used to determine the value of the car, V , after 5 years?
- 1) $V = 12,500(0.55)^5$
 - 2) $V = 12,500(0.955)^5$
 - 3) $V = 12,500(1.045)^5$
 - 4) $V = 12,500(1.45)^5$
- 576 If n is an odd integer, which equation can be used to find three consecutive odd integers whose sum is -3 ?
- 1) $n + (n + 1) + (n + 3) = -3$
 - 2) $n + (n + 1) + (n + 2) = -3$
 - 3) $n + (n + 2) + (n + 4) = -3$
 - 4) $n + (n + 2) + (n + 3) = -3$
- 577 Which set of data describes a situation that could be classified as qualitative?
- 1) the colors of the birds at the city zoo
 - 2) the shoe size of the zookeepers at the city zoo
 - 3) the heights of the giraffes at the city zoo
 - 4) the weights of the monkeys at the city zoo
- 578 What is the solution of the equation $\frac{x+2}{2} = \frac{4}{x}$?
- 1) 1 and -8
 - 2) 2 and -4
 - 3) -1 and 8
 - 4) -2 and 4
- 579 Express in simplest form: $\frac{x^2 - 1}{x^2 + 3x + 2}$
- 580 What is the slope of the line that passes through the points $(4, -7)$ and $(9, 1)$?
- 1) $\frac{5}{8}$
 - 2) $\frac{8}{5}$
 - 3) $-\frac{6}{12}$
 - 4) $-\frac{13}{6}$

581 What is the sum of $-3x^2 - 7x + 9$ and $-5x^2 + 6x - 4$?

- 1) $-8x^2 - x + 5$
- 2) $-8x^4 - x + 5$
- 3) $-8x^2 - 13x + 13$
- 4) $-8x^4 - 13x^2 + 13$

582 The box-and-whisker plot below represents the ages of 12 people.

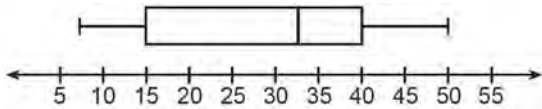

What percentage of these people are age 15 or older?

- 1) 25
- 2) 35
- 3) 75
- 4) 85

583 Peter walked 8,900 feet from home to school.

$1 \text{ mile} = 5,280 \text{ feet}$

How far, to the *nearest tenth of a mile*, did he walk?

- 1) 0.5
- 2) 0.6
- 3) 1.6
- 4) 1.7

584 Which expression represents “5 less than twice x ”?

- 1) $2x - 5$
- 2) $5 - 2x$
- 3) $2(5 - x)$
- 4) $2(x - 5)$

585 Which graph does *not* represent a function?

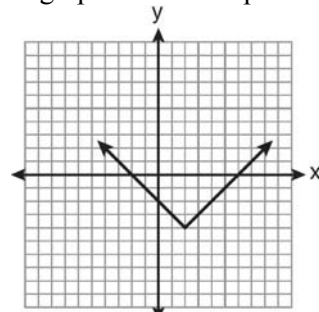

1)

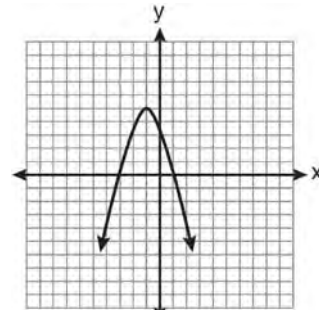

2)

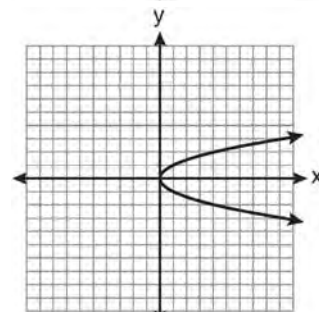

3)

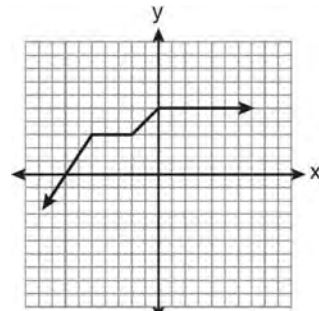

4)

- 586 In right triangle ABC shown below, $AC = 29$ inches, $AB = 17$ inches, and $m\angle ABC = 90$. Find the number of degrees in the measure of angle BAC , to the nearest degree.

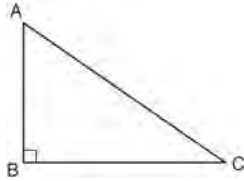

Find the length of \overline{BC} to the nearest inch.

- 587 In a given linear equation, the value of the independent variable decreases at a constant rate while the value of the dependent variable increases at a constant rate. The slope of this line is
- 1) positive
 - 2) negative
 - 3) zero
 - 4) undefined

- 588 Express $\sqrt{25} - 2\sqrt{3} + \sqrt{27} + 2\sqrt{9}$ in simplest radical form.

- 589 Miller's Department Store is having a sale with a 25% discount on mattresses. If the sales tax rate is 8%, how much change will Frank receive from \$800 if he purchases a mattress regularly priced at \$895 during this sale?

- 590 Given: $A = \{2, 4, 5, 7, 8\}$

$$B = \{3, 5, 8, 9\}$$

What is $A \cup B$?

- 1) $\{5\}$
 - 2) $\{5, 8\}$
 - 3) $\{2, 3, 4, 7, 9\}$
 - 4) $\{2, 3, 4, 5, 7, 8, 9\}$
- 591 Which equation represents the line that passes through the point $(3, 4)$ and is parallel to the x -axis?
- 1) $x = 4$
 - 2) $x = -3$
 - 3) $y = 4$
 - 4) $y = -3$
- 592 In $\triangle ABC$, $m\angle C = 90$. If $AB = 5$ and $AC = 4$, which statement is *not* true?
- 1) $\cos A = \frac{4}{5}$
 - 2) $\tan A = \frac{3}{4}$
 - 3) $\sin B = \frac{4}{5}$
 - 4) $\tan B = \frac{5}{3}$
- 593 Which ordered pair is in the solution set of the system of inequalities $y \leq 3x + 1$ and $x - y > 1$?
- 1) $(-1, -2)$
 - 2) $(2, -1)$
 - 3) $(1, 2)$
 - 4) $(-1, 2)$

594 Janis measures the dimensions of the floor in her rectangular classroom for a rug. Her measurements are 10.50 feet by 12.25 feet. The actual measurements of the floor are 10.75 feet by 12.50 feet. Determine the relative error in calculating the area, to the nearest thousandth.

- 597 The sum of $8n^2 - 3n + 10$ and $-3n^2 - 6n - 7$ is
- 1) $5n^2 - 9n + 3$
 - 2) $5n^2 - 3n - 17$
 - 3) $-11n^2 - 9n - 17$
 - 4) $-11n^2 - 3n + 3$

595 Which type of function is graphed below?

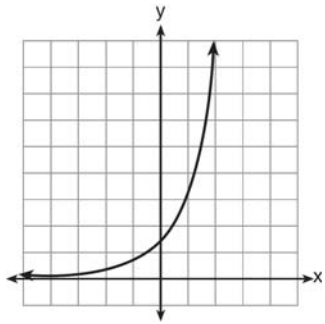

- 1) linear
- 2) quadratic
- 3) exponential
- 4) absolute value

596 A value of x that makes the expression

$$\frac{x^2 + 4x - 12}{x^2 - 2x - 15}$$
 undefined is

- 1) -6
- 2) -2
- 3) 3
- 4) 5

598 In the diagram below, circle O is inscribed in square $ABCD$. The square has an area of 36.

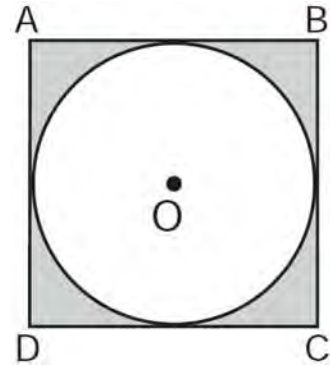

What is the area of the circle?

- 1) 9?
- 2) 6?
- 3) 3?
- 4) 36?

599 Carol plans to sell twice as many magazine subscriptions as Jennifer. If Carol and Jennifer need to sell at least 90 subscriptions in all, which inequality could be used to determine how many subscriptions, x , Jennifer needs to sell?

- 1) $x \geq 45$
- 2) $2x \geq 90$
- 3) $2x - x \geq 90$
- 4) $2x + x \geq 90$

- 600 A sandwich consists of one type of bread, one type of meat, and one type of cheese. The possible choices are listed below.

Bread: white, rye
Meat: ham, turkey, beef
Cheese: American, Swiss

Draw a tree diagram or list a sample space of all the possible different sandwiches consisting of one type of bread, one type of meat, and one type of cheese. Determine the number of sandwiches that will *not* include turkey. Determine the number of sandwiches that will include rye bread and Swiss cheese.

- 601 If $x = -3$, what is the value of $|x - 4| - x^2$?
- 1) -8
 - 2) -2
 - 3) 7
 - 4) 16

- 602 The vertex of the parabola $y = x^2 + 8x + 10$ lies in Quadrant
- 1) I
 - 2) II
 - 3) III
 - 4) IV

- 603 Which interval notation describes the set $S = \{x | 1 \leq x < 10\}$?
- 1) $[1, 10]$
 - 2) $(1, 10]$
 - 3) $[1, 10)$
 - 4) $(1, 10)$

- 604 What are the coordinates of the vertex and the equation of the axis of symmetry of the parabola shown in the graph below?

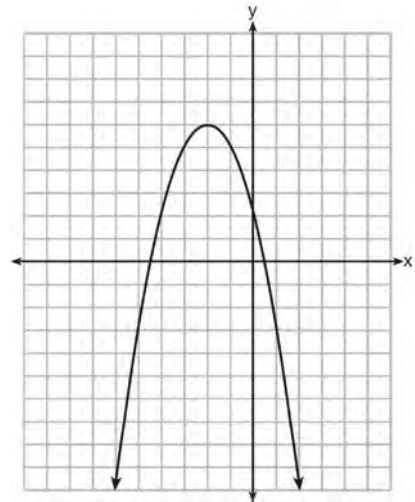

- 1) $(0, 2)$ and $y = 2$
 - 2) $(0, 2)$ and $x = 2$
 - 3) $(-2, 6)$ and $y = -2$
 - 4) $(-2, 6)$ and $x = -2$
- 605 The expression $\frac{2x + 13}{2x + 6} - \frac{3x - 6}{2x + 6}$ is equivalent to
- 1) $\frac{-x + 19}{2(x + 3)}$
 - 2) $\frac{-x + 7}{2(x + 3)}$
 - 3) $\frac{5x + 19}{2(x + 3)}$
 - 4) $\frac{5x + 7}{4x + 12}$

- 606 Campsite A and campsite B are located directly opposite each other on the shores of Lake Omega, as shown in the diagram below. The two campsites form a right triangle with Sam's position, S . The distance from campsite B to Sam's position is 1,300 yards, and campsite A is 1,700 yards from his position.

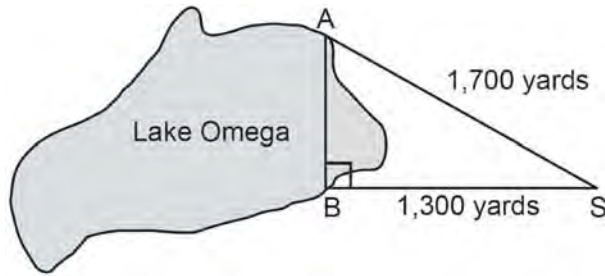

What is the distance from campsite A to campsite B , to the nearest yard?

- 1) 1,095
 - 2) 1,096
 - 3) 2,140
 - 4) 2,141
- 607 What is one-third of 3^6 ?
- 1) 1^2
 - 2) 3^2
 - 3) 3^5
 - 4) 9^6
- 608 A turtle and a rabbit are in a race to see who is first to reach a point 100 feet away. The turtle travels at a constant speed of 20 feet per minute for the entire 100 feet. The rabbit travels at a constant speed of 40 feet per minute for the first 50 feet, stops for 3 minutes, and then continues at a constant speed of 40 feet per minute for the last 50 feet. Determine which animal won the race and by how much time.

- 609 On the set of axes below, graph the equation $y = x^2 + 2x - 8$. Using the graph, determine and state the roots of the equation $x^2 + 2x - 8 = 0$.

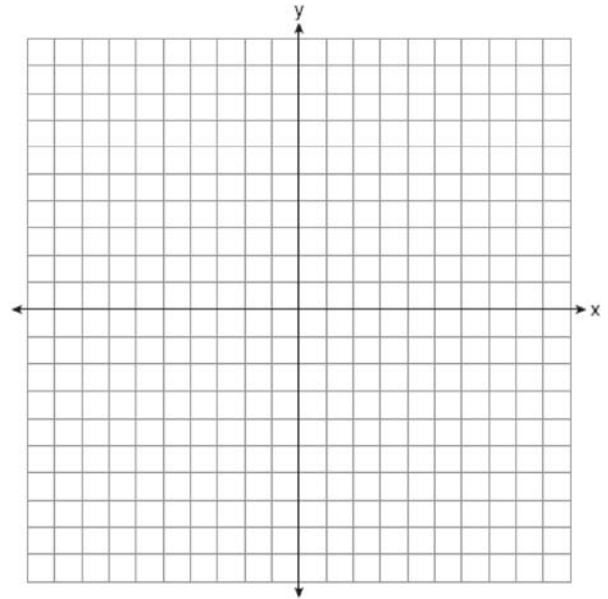

- 610 Which statement is true about the data set 4, 5, 6, 6, 7, 9, 12?
- 1) mean = mode
 - 2) mode = median
 - 3) mean < median
 - 4) mode > mean
- 611 Express $2\sqrt{108}$ in simplest radical form.

612 For which values of x is the fraction $\frac{x^2 + x - 6}{x^2 + 5x - 6}$

undefined?

- 1) 1 and -6
- 2) 2 and -3
- 3) 3 and -2
- 4) 6 and -1

613 What is the sum of $\frac{2y}{y+5}$ and $\frac{10}{y+5}$ expressed in simplest form?

- 1) 1
- 2) 2
- 3) $\frac{12y}{y+5}$
- 4) $\frac{2y+10}{y+5}$

614 The length and width of the base of a rectangular prism are 5.5 cm and 3 cm. The height of the prism is 6.75 cm. Find the *exact* value of the surface area of the prism, in square centimeters.

615 Three fair coins are tossed. What is the probability that two heads and one tail appear?

- 1) $\frac{1}{8}$
- 2) $\frac{3}{8}$
- 3) $\frac{3}{6}$
- 4) $\frac{2}{3}$

616 The diagram below shows right triangle LMP .

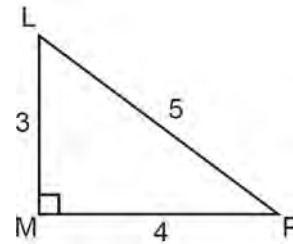

Which ratio represents the tangent of $\angle PLM$?

- 1) $\frac{3}{4}$
- 2) $\frac{3}{5}$
- 3) $\frac{4}{3}$
- 4) $\frac{5}{4}$

617 Which set builder notation describes $\{-2, -1, 0, 1, 2, 3\}$?

- 1) $\{x | -3 \leq x \leq 3, \text{ where } x \text{ is an integer}\}$
- 2) $\{x | -3 < x \leq 4, \text{ where } x \text{ is an integer}\}$
- 3) $\{x | -2 < x < 3, \text{ where } x \text{ is an integer}\}$
- 4) $\{x | -2 \leq x < 4, \text{ where } x \text{ is an integer}\}$

618 State the value of the expression

$$\frac{(4.1 \times 10^2)(2.4 \times 10^3)}{(1.5 \times 10^7)} \text{ in scientific notation.}$$

619 Which expression represents $\frac{x^2 - 3x - 10}{x^2 - 25}$ in simplest form?

- 1) $\frac{2}{5}$
- 2) $\frac{x+2}{x+5}$
- 3) $\frac{x-2}{x-5}$
- 4) $\frac{-3x-10}{-25}$

620 Which equation is an example of the use of the associative property of addition?

- 1) $x + 7 = 7 + x$
- 2) $3(x + y) = 3x + 3y$
- 3) $(x + y) + 3 = x + (y + 3)$
- 4) $3 + (x + y) = (x + y) + 3$

621 What is $2\sqrt{45}$ expressed in simplest radical form?

- 1) $3\sqrt{5}$
- 2) $5\sqrt{5}$
- 3) $6\sqrt{5}$
- 4) $18\sqrt{5}$

622 Solve algebraically for x : $2(x - 4) \geq \frac{1}{2}(5 - 3x)$

623 Which set of data can be classified as quantitative?

- 1) first names of students in a chess club
- 2) ages of students in a government class
- 3) hair colors of students in a debate club
- 4) favorite sports of students in a gym class

624 The distance from Earth to Mars is 136,000,000 miles. A spaceship travels at 31,000 miles per hour. Determine, to the *nearest day*, how long it will take the spaceship to reach Mars.

625 Based on the line of best fit drawn below, which value could be expected for the data in June 2015?

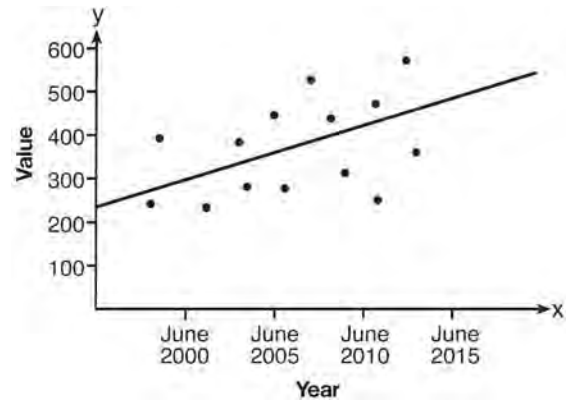

- 1) 230
- 2) 310
- 3) 480
- 4) 540

626 Jason's part-time job pays him \$155 a week. If he has already saved \$375, what is the minimum number of weeks he needs to work in order to have enough money to buy a dirt bike for \$900?

- 1) 8
- 2) 9
- 3) 3
- 4) 4

627 If $s = \frac{2x+t}{r}$, then x equals

- 1) $\frac{rs-t}{2}$
- 2) $\frac{rs+1}{2}$
- 3) $2rs-t$
- 4) $rs-2t$

628 Solve the inequality $-5(x-7) < 15$ algebraically for x .

629 Which equation represents a line that has a slope of $\frac{3}{4}$ and passes through the point $(2, 1)$?

- 1) $3y = 4x - 5$
- 2) $3y = 4x + 2$
- 3) $4y = 3x - 2$
- 4) $4y = 3x + 5$

630 If the expression $(2y^a)^4$ is equivalent to $16y^8$, what is the value of a ?

- 1) 12
- 2) 2
- 3) 32
- 4) 4

631 Which point lies on the graph represented by the equation $3y + 2x = 8$?

- 1) $(-2, 7)$
- 2) $(0, 4)$
- 3) $(2, 4)$
- 4) $(7, -2)$

632 If the point $(5, k)$ lies on the line represented by the equation $2x + y = 9$, the value of k is

- 1) 1
- 2) 2
- 3) -1
- 4) -2

633 The cumulative frequency table below shows the length of time that 30 students spent text messaging on a weekend.

Minutes Used	Cumulative Frequency
31-40	2
31-50	5
31-60	10
31-70	19
31-80	30

Which 10-minute interval contains the first quartile?

- 1) 31 - 40
- 2) 41 - 50
- 3) 51 - 60
- 4) 61 - 70

634 Which expression represents the number of hours in w weeks and d days?

- 1) $7w + 12d$
- 2) $84w + 24d$
- 3) $168w + 24d$
- 4) $168w + 60d$

635 Which graph represents the inequality $y > 3$?

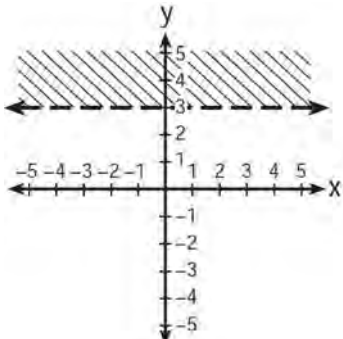

1)

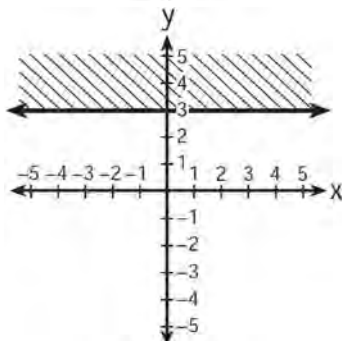

2)

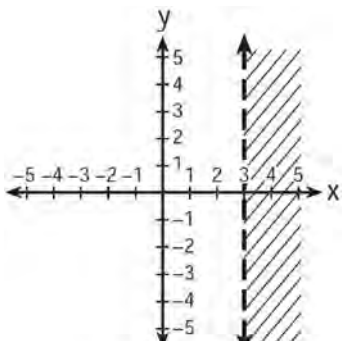

3)

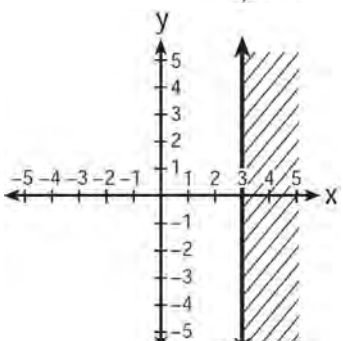

4)

636 On the set of axes below, graph the following system of equations.

$$y + 2x = x^2 + 4$$

$$y - x = 4$$

Using the graph, determine and state the coordinates of *all* points in the solution set for the system of equations.

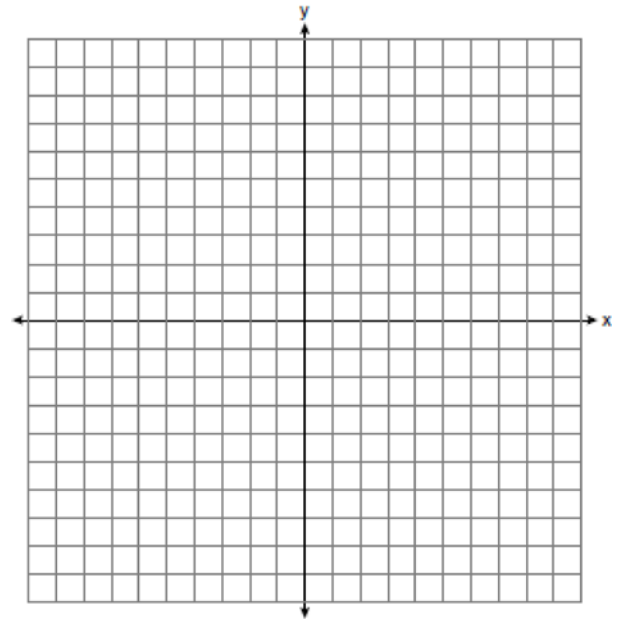

637 The length of one side of a square is 13 feet. What is the length, to the *nearest foot*, of a diagonal of the square?

- 1) 13
- 2) 18
- 3) 19
- 4) 26

- 638 The value of y in the equation $0.06y + 200 = 0.03y + 350$ is
- 1) 500
 - 2) $1,666.\bar{6}$
 - 3) 5,000
 - 4) $18,333.\bar{3}$

- 639 Which equation is represented by the graph below?

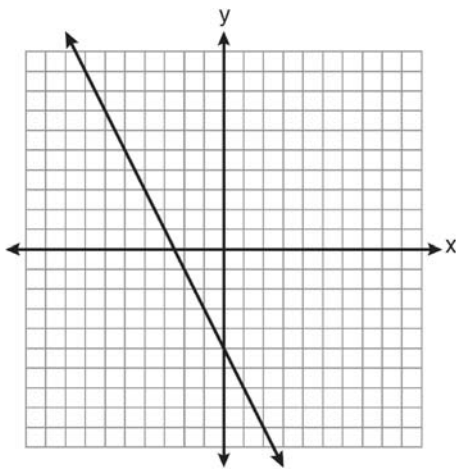

- 1) $2y + x = 10$
 - 2) $y - 2x = -5$
 - 3) $-2y = 10x - 4$
 - 4) $2y = -4x - 10$
- 640 The equation $3(4x) = (4x)3$ illustrates which property?
- 1) commutative
 - 2) associative
 - 3) distributive
 - 4) multiplicative inverse

- 641 Express the product of $\frac{x+2}{2}$ and $\frac{4x+20}{x^2+6x+8}$ in simplest form.

- 642 The scatter plot shown below represents a relationship between x and y .

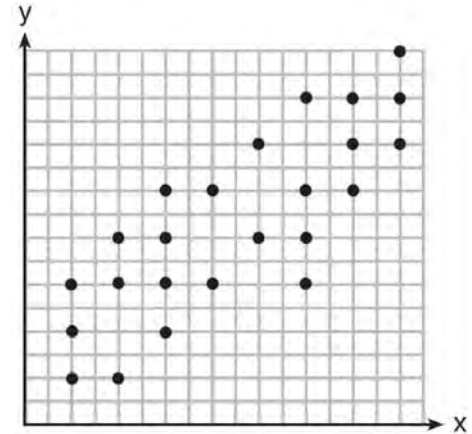

- This type of relationship is
- 1) a positive correlation
 - 2) a negative correlation
 - 3) a zero correlation
 - 4) not able to be determined

- 643 If the roots of a quadratic equation are -2 and 3 , the equation can be written as
- 1) $(x-2)(x+3) = 0$
 - 2) $(x+2)(x-3) = 0$
 - 3) $(x+2)(x+3) = 0$
 - 4) $(x-2)(x-3) = 0$

- 644 Written in set-builder notation, $S = \{1, 3, 5, 7, 9\}$ is
- 1) $\{x | 1 < x < 9, \text{ where } x \text{ is a prime number}\}$
 - 2) $\{x | 1 \leq x \leq 9, \text{ where } x \text{ is a prime number}\}$
 - 3) $\{x | 1 < x < 9, \text{ where } x \text{ is an odd integer}\}$
 - 4) $\{x | 1 \leq x \leq 9, \text{ where } x \text{ is an odd integer}\}$

645 A company is running a contest and offering a first, second, and third prize. First prize is a choice of a car or \$15,000 cash. Second prize is a choice of a motorbike, a trip to New York City, or \$2,000 cash. Third prize is a choice of a television or \$500 cash. If each prize is equally likely to be selected, list the sample space or draw a tree diagram of *all* possible different outcomes of first, second, and third prizes. Determine the number of ways that *all* three prizes selected could be cash. Determine the number of ways that *none* of the three prizes selected could be cash.

- 646 In triangle RST , angle R is a right angle. If $TR = 6$ and $TS = 8$, what is the length of RS ?
- 1) 10
 - 2) 2
 - 3) $2\sqrt{7}$
 - 4) $7\sqrt{2}$

- 647 What is the slope of the line that passes through the points $(2, -3)$ and $(5, 1)$?
- 1) $-\frac{2}{3}$
 - 2) $\frac{2}{3}$
 - 3) $-\frac{4}{3}$
 - 4) $\frac{4}{3}$

- 648 The number of hours spent on math homework during one week and the math exam grades for eleven students in Ms. Smith's algebra class are plotted below.

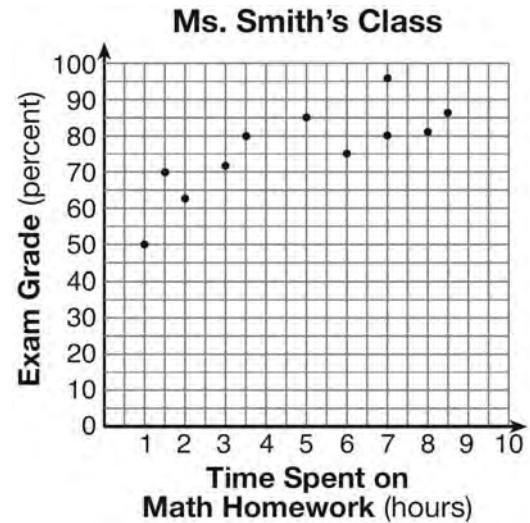

Based on the plotted data, what is the correlation between the time spent on homework and the exam grade?

- 1) positive
- 2) negative
- 3) no correlation
- 4) cannot be determined

- 649 The expression $\frac{6 \times 10^{-7}}{3 \times 10^{-3}}$ is equivalent to
- 1) 2×10^4
 - 2) 2×10^{10}
 - 3) 2×10^{-4}
 - 4) 2×10^{-10}

650 The expression $\frac{2x^2 + 10x - 28}{4x + 28}$ is equivalent to

- 1) $\frac{x-2}{2}$
- 2) $x-1$
- 3) $\frac{x+2}{2}$
- 4) $\frac{x+5}{2}$

651 Ashley measured the dimensions of a rectangular prism to be 6 cm by 10 cm by 1.5 cm. The actual dimensions are 5.9 cm by 10.3 cm by 1.7 cm. Determine the relative error, to the *nearest thousandth*, in calculating the volume of the prism.

652 In right triangle ABC shown below, what is the value of $\cos A$?

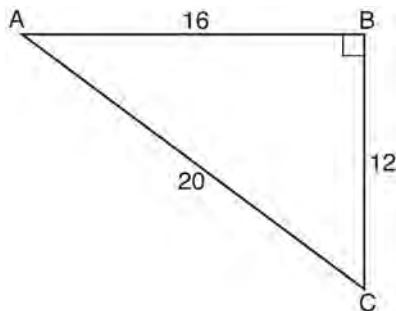

- 1) $\frac{12}{20}$
- 2) $\frac{16}{20}$
- 3) $\frac{20}{12}$
- 4) $\frac{20}{16}$

- 653 Which event is certain to happen?
- 1) Everyone walking into a room will have red hair.
 - 2) All babies born in June will be males.
 - 3) The Yankees baseball team will win the World Series.
 - 4) The Sun will rise in the east.

654 In a game, a player must spin each spinner shown in the diagram below once.

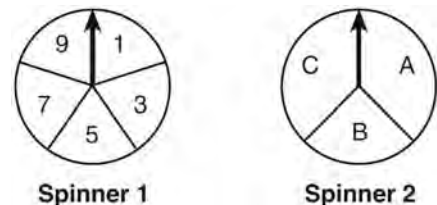

Draw a tree diagram or list a sample space showing all possible outcomes. Determine the number of outcomes that consist of a prime number and a letter in the word "CAT."

655 The solutions of $x^2 = 16x - 28$ are

- 1) -2 and -14
- 2) 2 and 14
- 3) -4 and -7
- 4) 4 and 7

656 Which equation is true?

- 1) $\frac{c^5}{d^7} \div \frac{d^3}{c} = \frac{c^4}{d^4}$
- 2) $(-2m^2p)^3 = -8m^6p^3$
- 3) $\left(\frac{s^3t^8}{s^4t^5}\right)^2 = \frac{t^5}{s^2}$
- 4) $(-2a^2b^3)(3ab^2) = a^3b^5$

Integrated Algebra Regents Exam Questions at Random

www.jmap.org

- 657 What is the product of $(3x + 2)$ and $(x - 7)$?
- 1) $3x^2 - 14$
 - 2) $3x^2 - 5x - 14$
 - 3) $3x^2 - 19x - 14$
 - 4) $3x^2 - 23x - 14$
- 658 Adrienne invested \$2000 in an account at a 3.5% interest rate compounded annually. She made no deposits or withdrawals on the account for 4 years. Determine, to the *nearest dollar*, the balance in the account after the 4 years.
- 659 Byron is 3 years older than Doug. The product of their ages is 40. How old is Doug?
- 1) 10
 - 2) 8
 - 3) 5
 - 4) 4
- 660 Mr. Smith invested \$2,500 in a savings account that earns 3% interest compounded annually. He made no additional deposits or withdrawals. Which expression can be used to determine the number of dollars in this account at the end of 4 years?
- 1) $2500(1 + 0.03)^4$
 - 2) $2500(1 + 0.3)^4$
 - 3) $2500(1 + 0.04)^3$
 - 4) $2500(1 + 0.4)^3$
- 661 The roots of the equation $3x^2 - 27x = 0$ are
- 1) 0 and 9
 - 2) 0 and -9
 - 3) 0 and 3
 - 4) 0 and -3
- 662 Given:
 $A = \{\text{all odd integers from 1 through 19, inclusive}\}$
 $B = \{9, 11, 13, 15, 17\}$
 What is the complement of set B within set A ?
- 1) $\{3, 5, 7\}$
 - 2) $\{3, 5, 7, 19\}$
 - 3) $\{1, 3, 5, 7\}$
 - 4) $\{1, 3, 5, 7, 19\}$
- 663 If $rx - st = r$, which expression represents x ?
- 1) $\frac{r + st}{r}$
 - 2) $\frac{r}{r + st}$
 - 3) $\frac{r}{r - st}$
 - 4) $\frac{r - st}{r}$
- 664 The inequality $-2 \leq x \leq 3$ can be written as
- 1) $(-2, 3)$
 - 2) $[-2, 3)$
 - 3) $(-2, 3]$
 - 4) $[-2, 3]$

- 665 The expression $\frac{14+x}{x^2-4}$ is undefined when x is
- 1) -14 , only
 - 2) 2 , only
 - 3) -2 or 2
 - 4) -14 , -2 , or 2

- 666 Which verbal expression is represented by $2(x+4)$?
- 1) twice the sum of a number and four
 - 2) the sum of two times a number and four
 - 3) two times the difference of a number and four
 - 4) twice the product of a number and four

- 667 Which equation could be used to find the measure of angle D in the right triangle shown in the diagram below?

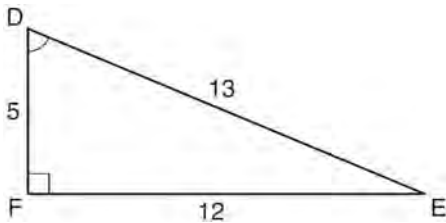

- 1) $\cos D = \frac{12}{13}$
- 2) $\cos D = \frac{13}{12}$
- 3) $\sin D = \frac{5}{13}$
- 4) $\sin D = \frac{12}{13}$

- 668 The volume of a cylindrical can is 32π cubic inches. If the height of the can is 2 inches, what is its radius, in inches?
- 1) 8
 - 2) 2
 - 3) 16
 - 4) 4

- 669 Which expression is equivalent to $\frac{2x^6 - 18x^4 + 2x^2}{2x^2}$?
- 1) $x^3 - 9x^2$
 - 2) $x^4 - 9x^2$
 - 3) $x^3 - 9x^2 + 1$
 - 4) $x^4 - 9x^2 + 1$

- 670 The length of a rectangle is 15 and its width is w . The perimeter of the rectangle is, *at most*, 50. Which inequality can be used to find the longest possible width?
- 1) $30 + 2w < 50$
 - 2) $30 + 2w \leq 50$
 - 3) $30 + 2w > 50$
 - 4) $30 + 2w \geq 50$

- 671 A car uses one gallon of gasoline for every 20 miles it travels. If a gallon of gasoline costs \$3.98, how much will the gas cost, to the *nearest dollar*, to travel 180 miles?
- 1) 9
 - 2) 36
 - 3) 45
 - 4) 80

- 672 If $A = \{0, 1, 3, 4, 6, 7\}$, $B = \{0, 2, 3, 5, 6\}$, and $C = \{0, 1, 4, 6, 7\}$, then $A \cap B \cap C$ is
- 1) $\{0, 1, 2, 3, 4, 5, 6, 7\}$
 - 2) $\{0, 3, 6\}$
 - 3) $\{0, 6\}$
 - 4) $\{0\}$

- 673 The rectangular prism shown below has a length of 3.0 cm, a width of 2.2 cm, and a height of 7.5 cm.

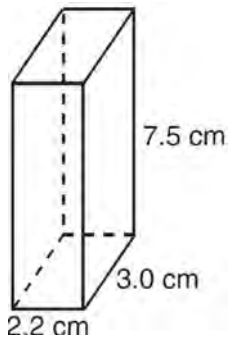

What is the surface area, in square centimeters?

- 1) 45.6
 - 2) 49.5
 - 3) 78.0
 - 4) 91.2
- 674 If $2y + 2w = x$, then w , in terms of x and y , is equal to
- 1) $x - y$
 - 2) $\frac{x - 2y}{2}$
 - 3) $x + y$
 - 4) $\frac{x + 2y}{2}$

- 675 Which graph does *not* represent the graph of a function?

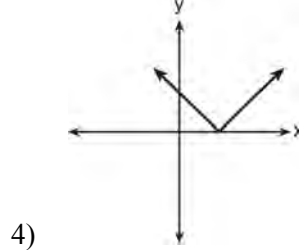
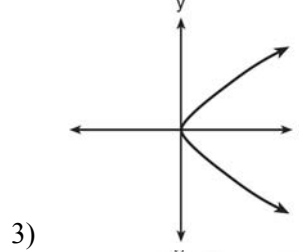
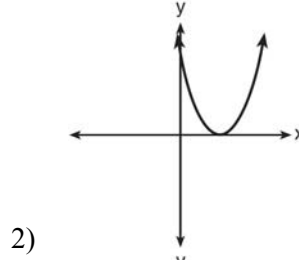
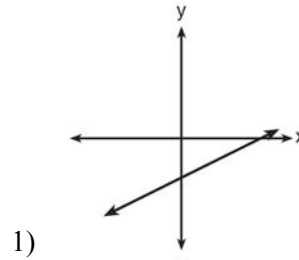

- 676 Express $\frac{3x^2 + 9x}{x^2 + 5x + 6} \div \frac{x^2 - 9}{x^2 - x - 6}$ in simplest form.

677 The diagram below shows the graph of which inequality?

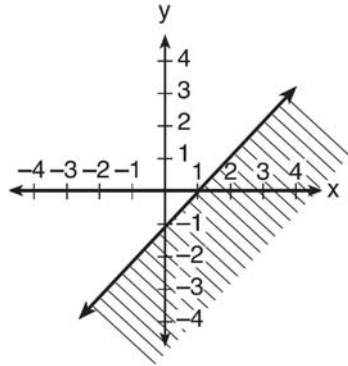

- 1) $y > x - 1$
- 2) $y \geq x - 1$
- 3) $y < x - 1$
- 4) $y \leq x - 1$

678 Marcy determined that her father's age is four less than three times her age. If x represents Marcy's age, which expression represents her father's age?

- 1) $3x - 4$
- 2) $3(x - 4)$
- 3) $4x - 3$
- 4) $4 - 3x$

679 A jar contains five red marbles and three green marbles. A marble is drawn at random and not replaced. A second marble is then drawn from the jar. Find the probability that the first marble is red and the second marble is green. Find the probability that both marbles are red. Find the probability that both marbles are the same color.

680 Which ratio represents the cosine of angle A in the right triangle below?

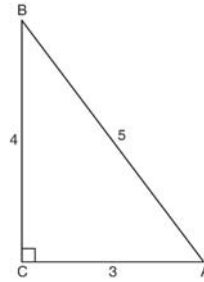

- 1) $\frac{3}{5}$
- 2) $\frac{5}{3}$
- 3) $\frac{4}{5}$
- 4) $\frac{4}{3}$

681 The box-and-whisker plot below represents the results of tests scores in a math class.

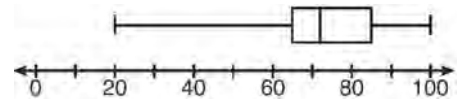

What do the scores 65, 85, and 100 represent?

- 1) Q_1 , median, Q_3
- 2) Q_1 , Q_3 , maximum
- 3) median, Q_1 , maximum
- 4) minimum, median, maximum

682 Which value of x is in the solution set of $-3x + 8 \geq 14$?

- 1) -3
- 2) -1
- 3) 0
- 4) 3

683 Which fraction is equivalent to $\frac{4}{3a} - \frac{5}{2a}$?

- 1) $-\frac{1}{a}$
- 2) $-\frac{1}{5a}$
- 3) $-\frac{7}{6a}$
- 4) $-\frac{7}{6a^2}$

684 The roots of a quadratic equation can be found using the graph below.

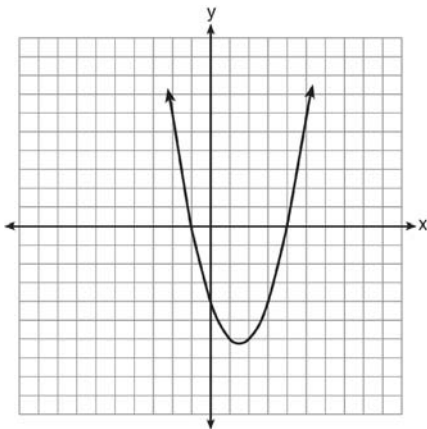

What are the roots of this equation?

- 1) -4, only
- 2) -4 and -1
- 3) -1 and 4
- 4) -4, -1, and 4

685 Given: $A = \{1, 3, 5, 7, 9\}$

$$B = \{2, 4, 6, 8, 10\}$$

$$C = \{2, 3, 5, 7\}$$

$$D = \{1, 2, 3, 4, 5, 6, 7, 8, 9, 10\}$$

What statement is *false*?

- 1) $A \cup B \cup C = D$
- 2) $A \cap B \cap C = \{\}$
- 3) $A \cup C = \{1, 2, 3, 5, 7\}$
- 4) $A \cap C = \{3, 5, 7\}$

686 A scatter plot was constructed on the graph below and a line of best fit was drawn.

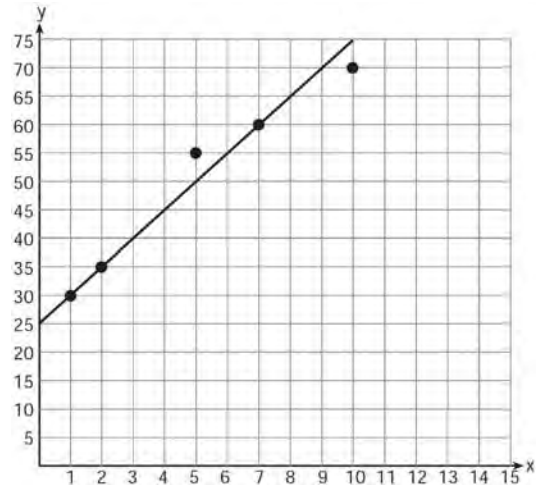

What is the equation of this line of best fit?

- 1) $y = x + 5$
- 2) $y = x + 25$
- 3) $y = 5x + 5$
- 4) $y = 5x + 25$

687 Factor completely: $5x^3 - 20x^2 - 60x$

Integrated Algebra Regents Exam Questions at Random

www.jmap.org

- 688 Mr. Stanton asked his students to write an algebraic expression on a piece of paper. He chose four students to go to the board and write their expression.

Robert wrote: $4(2x + 5) \geq 17$

Meredith wrote: $3y - 7 + 11z$

Steven wrote: $9w + 2 = 20$

Cynthia wrote: $8 + 10 - 4 = 14$

Which student wrote an algebraic expression?

- 1) Robert
- 2) Meredith
- 3) Steven
- 4) Cynthia

- 689 Using the substitution method, Ken solves the following system of equations algebraically.

$$2x - y = 5$$

$$3x + 2y = -3$$

Which equivalent equation could Ken use?

- 1) $3x + 2(2x - 5) = -3$
- 2) $3x + 2(5 - 2x) = -3$
- 3) $3\left(y + \frac{5}{2}\right) + 2y = -3$
- 4) $3\left(\frac{5}{2} - y\right) + 2y = -3$

- 690 Shana wants to buy a new bicycle that has a retail price of \$259.99. She knows that it will be on sale next week for 30% off the retail price. If the tax rate is 7%, find the total amount, to the *nearest cent*, that she will save by waiting until next week.

- 691 Which interval notation represents $-3 \leq x \leq 3$?

- 1) $[-3, 3]$
- 2) $(-3, 3]$
- 3) $[-3, 3)$
- 4) $(-3, 3)$

- 692 How many solutions are there for the following system of equations?

$$y = x^2 - 5x + 3$$

$$y = x - 6$$

- 1) 1
- 2) 2
- 3) 3
- 4) 0

- 693 A soda container holds $5\frac{1}{2}$ gallons of soda. How many ounces of soda does this container hold?

<p>1 quart = 32 ounces 1 gallon = 4 quarts</p>
--

- 1) 44
- 2) 176
- 3) 640
- 4) 704

- 694 Oatmeal is packaged in a cylindrical container, as shown in the diagram below.

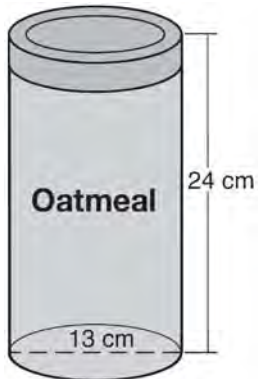

The diameter of the container is 13 centimeters and its height is 24 centimeters. Determine, in terms of π , the volume of the cylinder, in cubic centimeters.

- 695 What is the slope of the line represented by the equation $4x + 3y = 12$?

- 1) $\frac{4}{3}$
- 2) $\frac{3}{4}$
- 3) $-\frac{3}{4}$
- 4) $-\frac{4}{3}$

- 696 Timmy bought a skateboard and two helmets for a total of d dollars. If each helmet cost h dollars, the cost of the skateboard could be represented by

- 1) $2dh$
- 2) $\frac{dh}{2}$
- 3) $d - 2h$
- 4) $d - \frac{h}{2}$

- 697 A set of data is graphed on the scatter plot below.

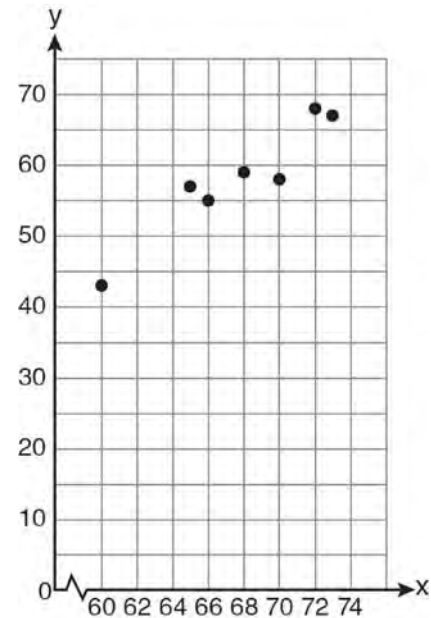

This scatter plot shows

- 1) no correlation
- 2) positive correlation
- 3) negative correlation
- 4) undefined correlation

- 698 Marie currently has a collection of 58 stamps. If she buys s stamps each week for w weeks, which expression represents the total number of stamps she will have?

- 1) $58sw$
- 2) $58 + sw$
- 3) $58s + w$
- 4) $58 + s + w$

- 699 A school newspaper will survey students about the quality of the school's lunch program. Which method will create the *least* biased results?
- 1) Twenty-five vegetarians are randomly surveyed.
 - 2) Twenty-five students are randomly chosen from each grade level.
 - 3) Students who dislike the school's lunch program are chosen to complete the survey.
 - 4) A booth is set up in the cafeteria for the students to voluntarily complete the survey.

- 700 Given:
 $A = \{\text{perfect square integers from 4-100, inclusive}\}$
 $B = \{16, 36, 49, 64\}$
The complement of set B in the universal set A is
- 1) $\{9, 25, 81\}$
 - 2) $\{4, 9, 25, 81, 100\}$
 - 3) $\{1, 4, 9, 25, 81, 100\}$
 - 4) $\{4, 16, 36, 49, 64, 100\}$

- 701 Is the equation $A = 21000(1 - 0.12)^t$ a model of exponential growth or exponential decay, and what is the rate (percent) of change per time period?
- 1) exponential growth and 12%
 - 2) exponential growth and 88%
 - 3) exponential decay and 12%
 - 4) exponential decay and 88%

- 702 Using the line provided, construct a box-and-whisker plot for the 12 scores below.
26, 32, 19, 65, 57, 16, 28, 42, 40, 21, 38, 10



Determine the number of scores that lie above the 75th percentile.

Integrated Algebra Regents at Random Answer Section

1 ANS: 3 PTS: 2 REF: 061101ia STA: A.A.19
TOP: Factoring the Difference of Perfect Squares

2 ANS:
81.3, 80, both increase

PTS: 3 REF: 011035ia STA: A.S.16 TOP: Central Tendency

3 ANS: 3
 $10^2 + 10^2 = c^2$
 $c^2 = 200$
 $c \approx 14.1$

PTS: 2 REF: 061102ia STA: A.A.45 TOP: Pythagorean Theorem

4 ANS:
2.1. $\cos 65 = \frac{x}{5}$
 $x \approx 2.1$

PTS: 2 REF: 011133ia STA: A.A.44 TOP: Using Trigonometry to Find a Side

5 ANS: 3
 $2(1)+3=5$

PTS: 2 REF: 061007ia STA: A.A.39 TOP: Linear Equations

6 ANS: 4 PTS: 2 REF: 011114ia STA: A.N.1
TOP: Properties of Reals

7 ANS:

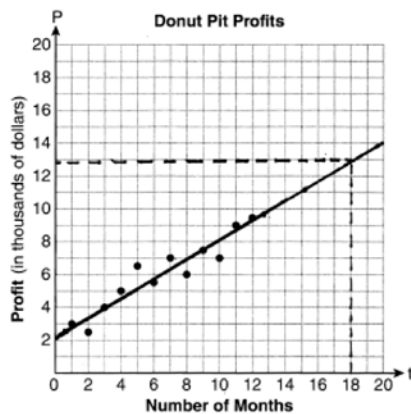

They will not reach their goal in 18 months.

PTS: 3 REF: 061036ia STA: A.S.17 TOP: Scatter Plots

8 ANS: 1 PTS: 2 REF: 061103ia STA: A.A.12
TOP: Division of Powers

9 ANS: 1

$$x = \frac{-b}{2a} = \frac{-6}{2(-1)} = 3.$$

PTS: 2 REF: 011127ia STA: A.A.41
TOP: Identifying the Vertex of a Quadratic Given Equation

10 ANS: 3 PTS: 2 REF: 081117ia STA: A.A.29
TOP: Set Theory

11 ANS: 1 PTS: 2 REF: 011126ia STA: A.A.13
TOP: Addition and Subtraction of Polynomials KEY: subtraction

12 ANS: 1

The slope of $2x - 4y = 16$ is $\frac{-A}{B} = \frac{-2}{-4} = \frac{1}{2}$

PTS: 2 REF: 011026ia STA: A.A.38 TOP: Parallel and Perpendicular Lines

13 ANS: 2

$$A = lw + lw + \frac{\pi r^2}{4} = 5 \cdot 3 + 5 \cdot 3 + \frac{\pi \cdot 3^2}{4} \approx 37$$

PTS: 2 REF: 011123ia STA: A.G.1 TOP: Compositions of Polygons and Circles
KEY: area

14 ANS:

$$\frac{x^2 + 9x + 14}{x^2 - 49} \div \frac{3x + 6}{x^2 + x - 56} = \frac{(x+7)(x+2)}{(x+7)(x-7)} \cdot \frac{(x+8)(x-7)}{3(x+2)} = \frac{x+8}{3}$$

PTS: 4 REF: 061037ia STA: A.A.18 TOP: Multiplication and Division of Rationals
KEY: division

15 ANS: 2 PTS: 2 REF: 081111ia STA: A.G.10
TOP: Identifying the Vertex of a Quadratic Given Graph

16 ANS: 2

$$2000(1 + 0.04)^3 \approx 2249$$

PTS: 2 REF: 081124ia STA: A.A.9 TOP: Exponential Functions

17 ANS:

30, 20, 71-80, 81-90 and 91-100

PTS: 4 REF: 061038ia STA: A.S.9
TOP: Frequency Histograms, Bar Graphs and Tables

18 ANS:

$$\begin{aligned} &2(x+3)(x-4) + 2(5)(x-4) + 2(x+3)(5) \\ &2(x^2 - 4x + 3x - 12) + 10(x-4) + 10(x+3) \\ &2x^2 - 2x - 24 + 10x - 40 + 10x + 30 \\ &2x^2 + 18x - 34 \end{aligned}$$

PTS: 3 REF: 061136ia STA: A.G.2 TOP: Surface Area

19 ANS: 1

$$\frac{12.8 + 17.2}{3 + 5} = 3.75$$

PTS: 2

REF: 061117ia

STA: A.M.1

TOP: Speed

20 ANS: 1

TOP: Set Theory

PTS: 2

REF: 061021ia

STA: A.A.29

21 ANS: 2

TOP: Expressions

PTS: 2

REF: 061121ia

STA: A.A.3

22 ANS: 4

TOP: Set Theory

PTS: 2

REF: 061123ia

STA: A.A.31

23 ANS: 4

TOP: Expressions

PTS: 2

REF: 061016ia

STA: A.A.2

24 ANS: 2

TOP: Scatter Plots

PTS: 2

REF: 011019ia

STA: A.S.12

25 ANS:

$$\frac{600 - 592}{592} \approx 0.014$$

PTS: 2

REF: 061031ia

STA: A.M.3

TOP: Error

KEY: volume and surface area

26 ANS: 4

$$5 \times 2 \times 3 = 30$$

PTS: 2

REF: 061002ia

STA: A.N.7

TOP: Multiplication Counting Principle

27 ANS: 2

$$\frac{2x - 3}{x - 4} = \frac{2}{3}$$

$$3(2x - 3) = 2(x - 4)$$

$$6x - 9 = 2x - 8$$

$$4x = 1$$

$$x = \frac{1}{4}$$

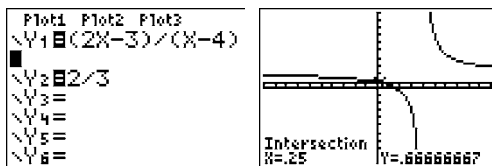

PTS: 2

REF: 081012ia

STA: A.A.26

TOP: Solving Rationals

28 ANS: 2

$$l(l - 3) = 40$$

$$l^2 - 3l - 40 = 0$$

$$(l - 8)(l + 5) = 0$$

$$l = 8$$

PTS: 2

REF: 081116ia

STA: A.A.8

TOP: Geometric Applications of Quadratics

29 ANS: 3

$$x^2 - 9 = 0$$

$$(x + 3)(x - 3) = 0$$

$$x = \pm 3$$

PTS: 2 REF: 061014ia STA: A.A.15 TOP: Undefined Rationals

30 ANS: 1 PTS: 2 REF: 061114ia STA: A.A.43

TOP: Using Trigonometry to Find an Angle

31 ANS: 4

$$\frac{9.2 \times 10^6}{2.3 \times 10^2} = 4 \times 10^4$$

PTS: 2 REF: 081006ia STA: A.N.4 TOP: Operations with Scientific Notation

32 ANS: 4 PTS: 2 REF: 011016ia STA: A.A.23

TOP: Transforming Formulas

33 ANS: 2 PTS: 2 REF: 081014ia STA: A.A.36

TOP: Parallel and Perpendicular Lines

34 ANS: 3

$${}_6P_4 = 360$$

PTS: 2 REF: 081028ia STA: A.N.8 TOP: Permutations

35 ANS: 1

Asking school district employees about a school board candidate produces the most bias.

PTS: 2 REF: 061107ia STA: A.S.3 TOP: Analysis of Data

36 ANS:

(T,J,F), (T,J,N), (T,K,F), (T,K,N), (T,C,F), (T,C,N), (B,J,F), (B,J,N), (B,K,F), (B,K,N), (B,C,F), (B,C,N), (S,J,F), (S,J,N), (S,K,F), (S,K,N), (S,C,F), (S,C,N). 3, 12.

PTS: 4 REF: 061138ia STA: A.S.19 TOP: Sample Space

37 ANS: 2 PTS: 2 REF: 011110ia STA: A.N.6

TOP: Evaluating Expressions

38 ANS: 1 PTS: 2 REF: 081115ia STA: A.A.32

TOP: Slope

39 ANS: 2

Debbie failed to distribute the 3 properly.

PTS: 2 REF: 011009ia STA: A.A.22 TOP: Solving Equations

40 ANS: 2

$$\tan ABC = \frac{\text{opposite}}{\text{adjacent}} = \frac{5}{12}$$

PTS: 2 REF: 081112ia STA: A.A.42 TOP: Trigonometric Ratios

41 ANS: 4

$${}_5P_5 = 5 \times 4 \times 3 \times 2 \times 1 = 120$$

PTS: 2

REF: 061109ia

STA: A.N.8

TOP: Permutations

42 ANS:

Interval	Tally	Frequency
51-60		2
61-70		2
71-80		4
81-90		6
91-100		4

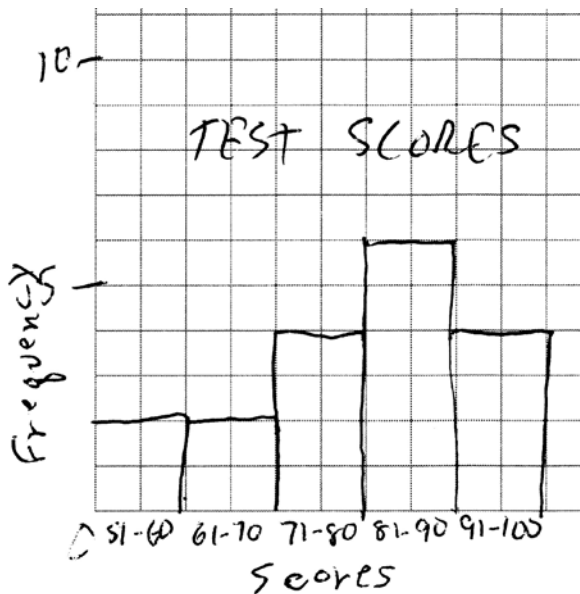

PTS: 3

REF: 011135ia

STA: A.S.5

TOP: Frequency Histograms, Bar Graphs and Tables

KEY: frequency histograms

43 ANS:

$$-2, 3. \quad x^2 - x = 6$$

$$x^2 - x - 6 = 0$$

$$(x - 3)(x + 2) = 0$$

$$x = 3 \text{ or } -2$$

PTS: 3

REF: 011034ia

STA: A.A.28

TOP: Roots of Quadratics

44 ANS: 2

PTS: 2

REF: 011012ia

STA: A.G.9

TOP: Quadratic-Linear Systems

45 ANS: 3

PTS: 2

REF: 061119ia

STA: A.A.2

TOP: Expressions

46 ANS:

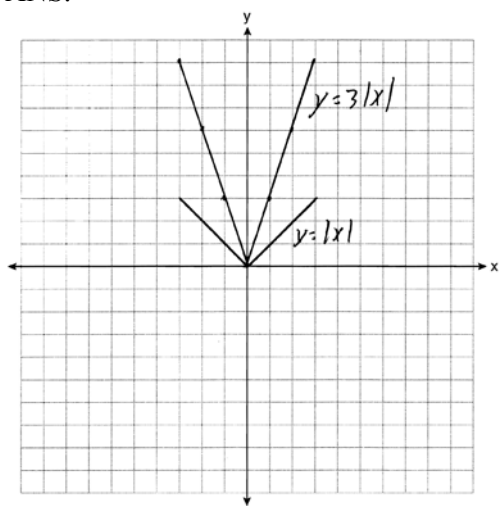

The graph becomes steeper.

PTS: 3

REF: 081134ia

STA: A.G.5

TOP: Graphing Absolute Value Functions

47 ANS: 2

PTS: 2

REF: 081104ia

STA: A.S.13

TOP: Analysis of Data

48 ANS:

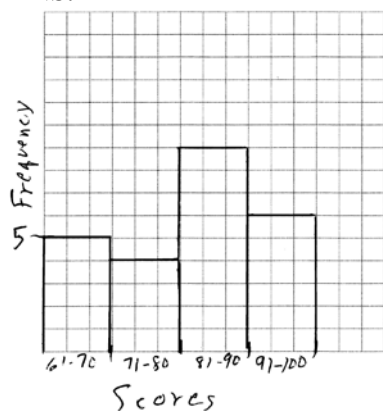

PTS: 2

REF: 081132ia

STA: A.S.5

KEY: frequency histograms

TOP: Frequency Histograms, Bar Graphs and Tables

49 ANS: 1

$$3(2m - 1) \leq 4m + 7$$

$$6m - 3 \leq 4m + 7$$

$$2m \leq 10$$

$$m \leq 5$$

PTS: 2

REF: 081002ia

STA: A.A.24

TOP: Solving Inequalities

50 ANS: 4

PTS: 2

REF: 061022ia

STA: A.S.3

TOP: Analysis of Data

51 ANS:

minimum is 120, 1st quartile is 145, median is 292, 3rd quartile is 407, and maximum is 452

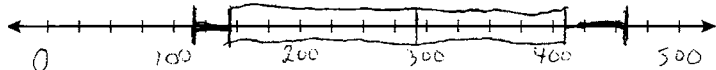

PTS: 3 REF: 081034ia STA: A.S.5 TOP: Box-and-Whisker Plots

52 ANS: 4

$$s = \frac{d}{t} = \frac{150 \text{ m}}{1.5 \text{ min}} \cdot \frac{60 \text{ min}}{1 \text{ hr}} = 6,000 \frac{\text{m}}{\text{hr}}$$

PTS: 2 REF: 061025ia STA: A.M.1 TOP: Speed

53 ANS: 3

mean = $81 \frac{7}{11}$, median = 81 and mode = 76

PTS: 2 REF: 011118ia STA: A.S.4 TOP: Central Tendency

54 ANS: 4 PTS: 2 REF: 061112ia STA: A.A.36

TOP: Parallel and Perpendicular Lines

55 ANS: 2

$$\left| \frac{13.5 - 12.8}{13.5} \right| \approx 0.093$$

PTS: 2 REF: 081123ia STA: A.M.3 TOP: Error

KEY: area

56 ANS:

$$2,160 \frac{1,200}{25} = \frac{x}{45}$$

$$25x = 54,000$$

$$x = 2,160$$

PTS: 2 REF: 081032ia STA: A.M.1 TOP: Using Rate

57 ANS:

$$-2\sqrt{3} \frac{16\sqrt{21}}{2\sqrt{7}} - 5\sqrt{12} = 8\sqrt{3} - 5\sqrt{4}\sqrt{3} = 8\sqrt{3} - 10\sqrt{3} = -2\sqrt{3}$$

PTS: 3 REF: 081136ia STA: A.N.3 TOP: Operations with Radicals

58 ANS: 4

$$SA = 2lw + 2hw + 2lh = 2(2)(3) + 2(4)(3) + 2(2)(4) = 52$$

PTS: 2 REF: 011029ia STA: A.G.2 TOP: Surface Area

59 ANS: 2

$$\frac{3}{2x} + \frac{7}{4x} = \frac{12x + 14x}{8x^2} = \frac{26x}{8x^2} = \frac{13}{4x}$$

PTS: 2 REF: 011120ia STA: A.A.17 TOP: Addition and Subtraction of Rationals

- 60 ANS: 1 PTS: 2 REF: 081110ia STA: A.A.1
TOP: Expressions
- 61 ANS: 3
$$\frac{2+x}{5x} - \frac{x-2}{5x} = \frac{2+x-x+2}{5x} = \frac{4}{5x}$$
- PTS: 2 REF: 081027ia STA: A.A.17 TOP: Addition and Subtraction of Rationals
- 62 ANS: 1 PTS: 2 REF: 081102ia STA: A.S.12
TOP: Scatter Plots
- 63 ANS: 1
$$-|a-b| = -|7-(-3)| = -|-10| = -10$$
- PTS: 2 REF: 011010ia STA: A.N.6 TOP: Evaluating Expressions
- 64 ANS:
$$77120 + 33500 = 110620 \text{ sq. ft.} \times \frac{1 \text{ acre}}{43560 \text{ sq. ft.}} \approx 2.54 \text{ acres}$$
- PTS: 2 REF: 081133ia STA: A.M.2 TOP: Conversions
KEY: dimensional analysis
- 65 ANS:
5.
$$48 \text{ inches} \times \frac{1 \text{ yard}}{36 \text{ inches}} = \frac{4}{3} \text{ yards} \times \$3.75 = \$5.00$$
- PTS: 2 REF: 011131ia STA: A.M.2 TOP: Conversions
KEY: dimensional analysis
- 66 ANS: 2
 $y - kx = 7$ may be rewritten as $y = kx + 7$
- PTS: 2 REF: 061015ia STA: A.A.38 TOP: Parallel and Perpendicular Lines
- 67 ANS:
$$-12. 3\left(\frac{2}{3}x + 3 < -2x - 7\right)$$

$$x + 9 < -6x - 21$$

$$7x < -30$$

$$x < \frac{-30}{7}$$
- PTS: 3 REF: 061034ia STA: A.A.21 TOP: Interpreting Solutions

68 ANS:

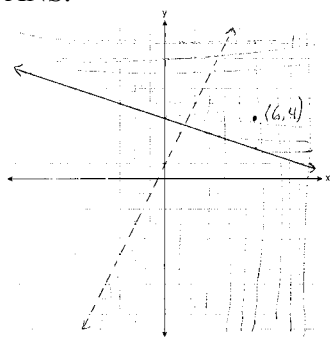

PTS: 4

REF: 081037ia

STA: A.G.7

TOP: Systems of Linear Inequalities

69 ANS: 2

$$\cos 38 = \frac{10}{x}$$

$$x = \frac{10}{\cos 38} \approx 12.69$$

PTS: 2

REF: 081126ia

STA: A.A.44

TOP: Using Trigonometry to Find a Side

70 ANS: 4

PTS: 2

REF: 011020ia

STA: A.A.12

TOP: Multiplication of Powers

71 ANS: 4

PTS: 2

REF: 061130ia

STA: A.A.13

TOP: Addition and Subtraction of Polynomials

KEY: subtraction

72 ANS: 2

$$R = 0.5^{d-1}$$

PTS: 2

REF: 011006ia

STA: A.A.9

TOP: Exponential Functions

73 ANS: 4

PTS: 2

REF: 011111ia

STA: A.G.8

TOP: Solving Quadratics by Graphing

74 ANS: 2

$$36x^2 - 100y^6 = 4(9x^2 - 25y^6) = 4(3x + 5y^3)(3x - 5y^3)$$

PTS: 2

REF: 081129ia

STA: A.A.19

TOP: Factoring the Difference of Perfect Squares

75 ANS:

$$0.102 \cdot \frac{(5.3 \times 8.2 \times 4.1) - (5 \times 8 \times 4)}{5.3 \times 8.2 \times 4.1} = \frac{178.16 - 160}{178.16} = 0.102$$

PTS: 3

REF: 011036ia

STA: A.M.3

TOP: Error

KEY: volume and surface area

76 ANS: 3

PTS: 2

REF: 011017ia

STA: A.G.5

TOP: Graphing Absolute Value Functions

77 ANS: 3

$$\frac{12x^3 - 6x^2 + 2x}{2x} = \frac{2x(6x^2 - 3x + 1)}{2x} = 6x^2 - 3x + 1$$

PTS: 2 REF: 011011ia STA: A.A.14 TOP: Division of Polynomials

78 ANS: 2

$$a^3 - 4a = a(a^2 - 4) = a(a - 2)(a + 2)$$

PTS: 2 REF: 011108ia STA: A.A.19
TOP: Factoring the Difference of Perfect Squares

79 ANS:

-6a + 42. distributive

PTS: 2 REF: 061032ia STA: A.N.1 TOP: Properties of Reals

80 ANS: 4

In (4), each element in the domain corresponds to a unique element in the range.

PTS: 2 REF: 011105ia STA: A.G.3 TOP: Defining Functions
KEY: ordered pairs

81 ANS:

$$-15, 2 \quad x^2 + 13x - 30 = 0$$

$$(x + 15)(x - 2) = 0$$

$$x = -15, 2$$

PTS: 3 REF: 081036ia STA: A.A.28 TOP: Roots of Quadratics

82 ANS: 1

PTS: 2

REF: 061024ia

STA: A.A.17

TOP: Addition and Subtraction of Rationals

83 ANS: 3

$$\cos A = \frac{\text{adjacent}}{\text{hypotenuse}} = \frac{15}{17}$$

PTS: 2 REF: 011008ia STA: A.A.42 TOP: Trigonometric Ratios

84 ANS: 4

PTS: 2

REF: 081022ia

STA: A.A.29

TOP: Set Theory

85 ANS: 3

PTS: 2

REF: 061011ia

STA: A.S.2

TOP: Analysis of Data

86 ANS:

12, 7. Both the median and the mode will increase.

PTS: 3 REF: 061134ia STA: A.S.16 TOP: Central Tendency

87 ANS:

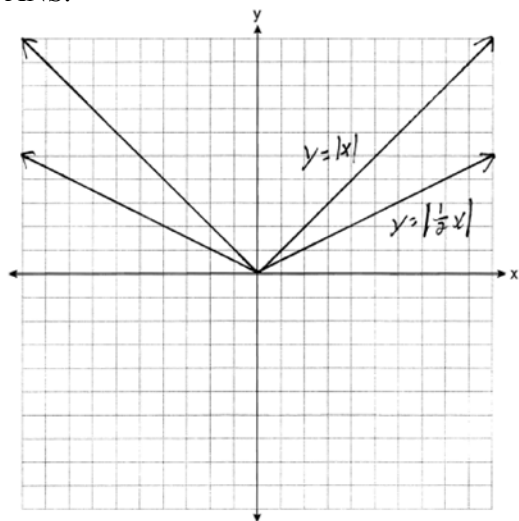

. Graph becomes wider as the coefficient approaches 0.

PTS: 3

REF: 061035ia

STA: A.G.5

TOP: Graphing Absolute Value Functions

88 ANS: 3

$$3\sqrt{2} + \sqrt{8} = 3\sqrt{2} + \sqrt{4}\sqrt{2} = 3\sqrt{2} + 2\sqrt{2} = 5\sqrt{2}$$

PTS: 2

REF: 011121ia

STA: A.N.3

TOP: Operations with Radicals

KEY: addition

89 ANS: 2

PTS: 2

REF: 061122ia

STA: A.S.14

TOP: Analysis of Data

90 ANS:

$$3a^2b^2 - 6a \cdot \frac{45a^4b^3 - 90a^3b}{15a^2b} = \frac{45a^4b^3}{15a^2b} - \frac{90a^3b}{15a^2b} = 3a^2b^2 - 6a$$

PTS: 2

REF: 081031ia

STA: A.A.14

TOP: Division of Polynomials

91 ANS: 1

$$\frac{x^2 - x - 6}{x^2 - 5x + 6} = \frac{(x-3)(x+2)}{(x-3)(x+2)} = \frac{x+2}{x-2}$$

PTS: 2

REF: 011130ia

STA: A.A.16

TOP: Rational Expressions

KEY: $a > 0$

92 ANS:

$$\text{orchestra: } \frac{3}{26} > \frac{4}{36}$$

PTS: 2

REF: 011033ia

STA: A.S.22

TOP: Theoretical Probability

93 ANS: 4

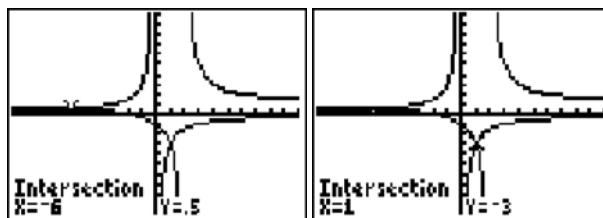

$$\frac{x+2}{x-2} = \frac{-3}{x}$$

$$x(x+2) = -3(x-2)$$

$$x^2 + 2x = -3x + 6$$

$$x^2 + 5x - 6 = 0$$

$$(x+6)(x-1) = 0$$

$$x = -6 \text{ or } 1$$

PTS: 2 REF: 011028ia STA: A.A.26 TOP: Solving Rationals

94 ANS: 2

$$\tan A = \frac{\text{opposite}}{\text{adjacent}} = \frac{14}{48}$$

PTS: 2 REF: 061009ia STA: A.A.42 TOP: Trigonometric Ratios

95 ANS: 3 PTS: 2 REF: 081008ia STA: A.A.19

TOP: Factoring the Difference of Perfect Squares

96 ANS: 4

$${}_8P_3 = 336$$

PTS: 2 REF: 061026ia STA: A.N.8 TOP: Permutations

97 ANS:

$$4, -5. \quad \frac{x+2}{6} = \frac{3}{x-1}$$

$$(x+2)(x-1) = 18$$

$$x^2 - x + 2x - 2 = 18$$

$$x^2 + x - 20 = 0$$

$$(x+5)(x-4) = 0$$

$$x = -5 \text{ or } 4$$

PTS: 3 REF: 011136ia STA: A.A.26 TOP: Solving Rationals

98 ANS: 2 PTS: 2 REF: 011027ia STA: A.A.3

TOP: Expressions

99 ANS: 3

$$75 - 15 = 60$$

PTS: 2 REF: 011113ia STA: A.S.6 TOP: Box-and-Whisker Plots

100 ANS:

$$\frac{m}{5} + \frac{3(m-1)}{2} = 2(m-3)$$

$$\frac{2m}{10} + \frac{15(m-1)}{10} = 2m - 6$$

$$\frac{17m-15}{10} = 2m-6$$

$$17m-15 = 20m-60$$

$$45 = 3m$$

$$15 = m$$

PTS: 4 REF: 081139ia STA: A.A.25

TOP: Solving Equations with Fractional Expressions

101 ANS: 2

$$\sqrt{18.4^2 - 7^2} \approx 17$$

PTS: 2 REF: 011107ia STA: A.A.45 TOP: Pythagorean Theorem

102 ANS: 2 PTS: 2 REF: 061115ia STA: A.S.7

TOP: Scatter Plots

103 ANS: 4 PTS: 2 REF: 081107ia STA: A.A.5

TOP: Modeling Inequalities

104 ANS: 3

$$P(O) = \frac{5}{10}, P(P) = \frac{4}{10}, P(\leq 5) = \frac{6}{10}, P(/3) = \frac{4}{10}$$

PTS: 2 REF: 081125ia STA: A.S.22 TOP: Theoretical Probability

105 ANS:

$$53. \sin A = \frac{16}{20}$$

$$A \approx 53$$

PTS: 2 REF: 011032ia STA: A.A.43 TOP: Using Trigonometry to Find an Angle

106 ANS: 3

$$\frac{(10w^3)^2}{5w} = \frac{100w^6}{5w} = 20w^5$$

PTS: 2 REF: 011124ia STA: A.A.12 TOP: Powers of Powers

107 ANS: 1

$$f + m = 53$$

$$f - m = 25$$

$$2m = 28$$

$$m = 14$$

PTS: 2 REF: 061126ia STA: A.A.7 TOP: Writing Linear Systems

108 ANS: 2

shaded = whole – unshaded

= rectangle-triangle

$$= lw - \frac{1}{2}bh$$

$$= 15 \times 6 - \frac{1}{2} \times 15 \times 4.6$$

$$= 90 - 34.5$$

$$= 55.5$$

PTS: 2

REF: 081019ia

STA: A.G.1

TOP: Compositions of Polygons and Circles

KEY: area

109 ANS: 3

$$m = \frac{7-3}{-3-3} = \frac{4}{-6} = -\frac{2}{3} \quad y = mx + b$$

$$3 = -\frac{2}{3}(3) + b$$

$$3 = -2 + b$$

$$5 = b$$

PTS: 2

REF: 011013ia

STA: A.A.35

TOP: Writing Linear Equations

110 ANS: 4

PTS: 2

REF: 081025ia

STA: A.G.4

TOP: Families of Functions

111 ANS: 1

$$-3(-4)^2(2) + 4(-4) = -96 - 16 = -112$$

PTS: 2

REF: 081113ia

STA: A.N.6

TOP: Evaluating Expressions

112 ANS: 1

PTS: 2

REF: 011101ia

STA: A.A.31

TOP: Set Theory

113 ANS: 4

$$A(-3,4) \text{ and } B(5,8). \quad m = \frac{4-8}{-3-5} = \frac{-4}{-8} = \frac{1}{2}$$

PTS: 2

REF: 011007ia

STA: A.A.33

TOP: Slope

114 ANS: 2

$$J - M = 3$$

$$8J + 8M = 120$$

$$8J - 8M = 24$$

$$16J = 144$$

$$J = 9$$

PTS: 2

REF: 011115ia

STA: A.A.7

TOP: Writing Linear Systems

115 ANS: 3

The age of a child does not cause the number of siblings he has, or vice versa.

PTS: 2

REF: 011030ia

STA: A.S.14

TOP: Analysis of Data

116 ANS: 3

PTS: 2

REF: 081017a

STA: A.S.14

TOP: Analysis of Data

117 ANS: 2

$$x^2 - 2x - 15 = 0$$

$$(x - 5)(x + 3) = 0$$

$$x = 5 \quad x = -3$$

PTS: 2

REF: 011128ia

STA: A.A.28

TOP: Roots of Quadratics

118 ANS: 3

PTS: 2

REF: 011117ia

STA: A.G.4

TOP: Graphing Absolute Value Functions

119 ANS: 1

PTS: 2

REF: 081030ia

STA: A.A.3

TOP: Expressions

120 ANS: 1

$$2(x - 4) = 4(2x + 1)$$

$$2x - 8 = 8x + 4$$

$$-12 = 6x$$

$$-2 = x$$

PTS: 2

REF: 011106ia

STA: A.A.22

TOP: Solving Equations

121 ANS: 3

$$\frac{15}{15 + 13 + 12} = \frac{15}{40} = \frac{3}{8}$$

PTS: 2

REF: 061006ia

STA: A.S.21

TOP: Experimental Probability

122 ANS:

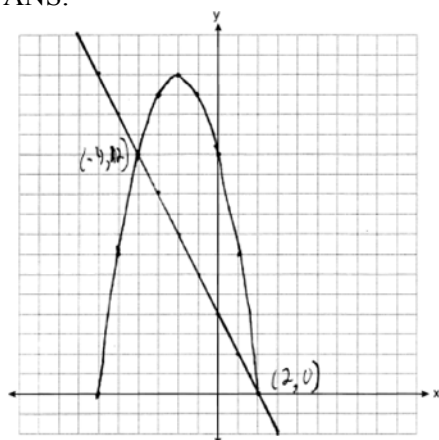

PTS: 4

REF: 061039ia

STA: A.G.9

TOP: Quadratic-Linear Systems

123 ANS: 3

$$\sqrt{72} - 3\sqrt{2} = \sqrt{36} \sqrt{2} - 3\sqrt{2} = 6\sqrt{2} - 3\sqrt{2} = 3\sqrt{2}$$

PTS: 2

REF: 061008ia

STA: A.N.3

TOP: Operations with Radicals

KEY: subtraction

124 ANS: 4

$$5(x + 4) = 5x + 20$$

PTS: 2

REF: 081013ia

STA: A.A.1

TOP: Expressions

125 ANS: 4

PTS: 2

REF: 061111ia

STA: A.G.4

TOP: Families of Functions

126 ANS: 3

$$P(\text{odd}) = \frac{3}{6}, P(\text{prime}) = \frac{3}{6}, P(\text{perfect square}) = \frac{2}{6}, P(\text{even}) = \frac{3}{6}$$

PTS: 2

REF: 061104ia

STA: A.S.22

TOP: Geometric Probability

127 ANS: 3

PTS: 2

REF: 061017ia

STA: A.S.11

TOP: Quartiles and Percentiles

128 ANS:

$$84, 71 \quad \sin 50 = \frac{x}{110} \quad \cos 50 = \frac{y}{110}$$

$$x \approx 84 \quad y \approx 71$$

PTS: 4

REF: 081039ia

STA: A.A.44

TOP: Using Trigonometry to Find a Side

129 ANS:

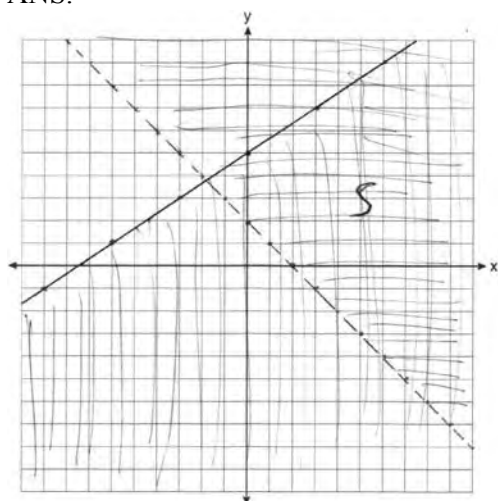

PTS: 4

REF: 011139ia

STA: A.G.7

TOP: Systems of Linear Inequalities

130 ANS: 3

PTS: 2

REF: 081103ia

STA: A.A.30

TOP: Set Theory

131 ANS: 2

PTS: 2

REF: 011023ia

STA: A.A.40

TOP: Systems of Linear Inequalities

132 ANS: 3

$$x = \frac{-b}{2a} = \frac{-10}{2(-1)} = 5.$$

PTS: 2 REF: 081018ia STA: A.A.41
TOP: Identifying the Vertex of a Quadratic Given Equation

133 ANS: 4

The other situations are quantitative.

PTS: 2 REF: 081122ia STA: A.S.1 TOP: Analysis of Data

134 ANS: 3

$$c + 3d = 8 \quad c = 4d - 6$$

$$4d - 6 + 3d = 8 \quad c = 4(2) - 6$$

$$7d = 14 \quad c = 2$$

$$d = 2$$

PTS: 2 REF: 061012ia STA: A.A.10 TOP: Solving Linear Systems

135 ANS: 2 PTS: 2 REF: 061113ia STA: A.G.5

TOP: Graphing Quadratic Functions

136 ANS: 4 PTS: 2 REF: 081011ia STA: A.A.5

TOP: Modeling Equations

137 ANS: 2

$$m = \frac{-A}{B} = \frac{-3}{-7} = \frac{3}{7}$$

PTS: 2 REF: 011122ia STA: A.A.37 TOP: Slope

138 ANS:

$$-3\sqrt{48} = -3\sqrt{16}\sqrt{3} = -12\sqrt{3}$$

PTS: 2 REF: 081033ia STA: A.N.2 TOP: Simplifying Radicals

139 ANS:

15,600,000, 4,368,000. $10 \times 10 \times 10 \times 26 \times 25 \times 24 = 15,600,000$. $10 \times 9 \times 8 \times 26 \times 25 \times 24 = 11,232,000$.
 $15,600,000 - 11,232,000 = 4,368,000$.

PTS: 4 REF: 011037ia STA: A.N.8 TOP: Permutations

140 ANS: 1 PTS: 2 REF: 061010ia STA: A.A.40

TOP: Systems of Linear Inequalities

141 ANS: 1

$$x^2 - 36 = 5x$$

$$x^2 - 5x - 36 = 0$$

$$(x - 9)(x + 4) = 0$$

$$x = 9$$

PTS: 2 REF: 061020ia STA: A.A.8 TOP: Writing Quadratics

142 ANS: 2
 $2(x - 3y = -3)$
 $2x + y = 8$
 $2x - 6y = -6$
 $7y = 14$
 $y = 2$

PTS: 2 REF: 081021ia STA: A.A.10 TOP: Solving Linear Systems

143 ANS: 4
 The other sets of data are qualitative.

PTS: 2 REF: 011116ia STA: A.S.1 TOP: Analysis of Data

144 ANS: 2

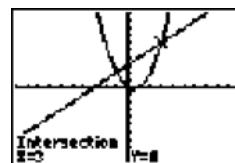

$x^2 - x = x + 3$. Since $y = x + 3$, the solutions are $(3, 6)$ and $(-1, 2)$.

$$x^2 - 2x - 3 = 0$$

$$(x - 3)(x + 1) = 0$$

$$x = 3 \text{ or } -1$$

PTS: 2 REF: 061118ia STA: A.A.11 TOP: Quadratic-Linear Systems

145 ANS:

$$-\frac{9}{4} \cdot \frac{3}{4} = \frac{-(x + 11)}{4x} + \frac{1}{2x}$$

$$\frac{3}{4} = \frac{-x - 11}{4x} + \frac{2}{4x}$$

$$\frac{3}{4} = \frac{-x - 9}{4x}$$

$$12x = -4x - 36$$

$$16x = -36$$

$$x = -\frac{9}{4}$$

PTS: 4 REF: 061137ia STA: A.A.26 TOP: Solving Rationals

146 ANS: 4 PTS: 2 REF: 061001ia STA: A.A.30

TOP: Set Theory

147 ANS: 2

$$A(-3, 8) \text{ and } B(3, 6). \quad m = \frac{8 - 6}{-3 - 3} = \frac{2}{-6} = -\frac{1}{3}$$

PTS: 2 REF: 081005ia STA: A.A.33 TOP: Slope

148 ANS: 4

$$-6x - 17 \geq 8x + 25$$

$$-42 \geq 14x$$

$$-3 \geq x$$

PTS: 2

REF: 081121ia

STA: A.A.24

TOP: Solving Inequalities

149 ANS: 3

$$2x - 5y = 11 \quad 2x - 5(-1) = 11$$

$$-2x + 3y = -9$$

$$2x = 6$$

$$-2y = 2$$

$$x = 3$$

$$y = -1$$

PTS: 2

REF: 081109ia

STA: A.A.10

TOP: Solving Linear Systems

150 ANS: 4

$$-3x(x - 4) - 2x(x + 3) = -3x^2 + 12x - 2x^2 - 6x = -5x^2 + 6x$$

PTS: 2

REF: 081114ia

STA: A.A.13

TOP: Addition and Subtraction of Monomials

151 ANS: 2

In (2), each element in the domain corresponds to a unique element in the range.

PTS: 2

REF: 061116ia

STA: A.G.3

TOP: Defining Functions

KEY: ordered pairs

152 ANS: 2

PTS: 2

REF: 061027ia

STA: A.A.20

TOP: Factoring Polynomials

153 ANS: 3

PTS: 2

REF: 081118ia

STA: A.G.4

TOP: Families of Functions

154 ANS: 2

PTS: 2

REF: 011002ia

STA: A.S.20

TOP: Theoretical Probability

155 ANS:

$$0.029 \cdot \frac{[2\pi(5.1)^2 + 2\pi(5.1)(15.1)] - [2\pi(5)^2 + 2\pi(5)(15)]}{2\pi(5.1)^2 + 2\pi(5.1)(15.1)} \approx \frac{647.294 - 628.319}{647.294} \approx 0.029$$

PTS: 4

REF: 011137ia

STA: A.M.3

TOP: Error

KEY: volume and surface area

156 ANS: 1

$$\frac{2x}{3} + \frac{1}{2} = \frac{5}{6}$$

$$\frac{2x}{3} = \frac{1}{3}$$

$$6x = 3$$

$$x = \frac{1}{2}$$

PTS: 2 REF: 011112ia STA: A.A.25

TOP: Solving Equations with Fractional Expressions

157 ANS: 3

$$V = \pi r^2 h = \pi \cdot 5^2 \cdot 2.3 \approx 180.6$$

PTS: 2 REF: 081105ia STA: A.G.2 TOP: Volume

158 ANS:

6, 8, 10. Three consecutive even integers are x , $x + 2$ and $x + 4$. $(x + 2)(x + 4) = 10x + 20$

$$x^2 + 6x + 8 = 10x + 20$$

$$x^2 - 4x - 12 = 0$$

$$(x - 6)(x + 2) = 0$$

$$x = 6$$

PTS: 4 REF: 011039ia STA: A.A.8 TOP: Writing Quadratics

159 ANS: 3 PTS: 2 REF: 081009ia STA: A.A.30

TOP: Set Theory

160 ANS: 1

$$7 + 8 + 7 + \frac{12\pi}{2} = 22 + 6\pi$$

PTS: 2 REF: 081128ia STA: A.G.1 TOP: Compositions of Polygons and Circles

KEY: perimeter

161 ANS: 1 PTS: 2 REF: 061005ia STA: A.G.10

TOP: Identifying the Vertex of a Quadratic Given Graph

162 ANS: 2

$$A = lw + \frac{\pi r^2}{2} = 6 \cdot 5 + \frac{\pi \cdot 3^2}{2} \approx 44.1$$

PTS: 2 REF: 061029ia STA: A.G.1 TOP: Compositions of Polygons and Circles

KEY: area

163 ANS: 3 PTS: 2 REF: 061003ia STA: A.A.13

TOP: Addition and Subtraction of Polynomials KEY: addition

164 ANS: 2

Candidate B received 45%. $45\% \times 1860 = 837$

PTS: 2 REF: 081007ia STA: A.N.5 TOP: Percents

165 ANS: 4

$$x^2 - 4x - 12 = 0$$

$$(x - 6)(x + 2) = 0$$

$$x = 6 \quad x = -2$$

PTS: 2 REF: 061125ia STA: A.A.15 TOP: Undefined Rationals

166 ANS: 4

In (4), each element in the domain corresponds to a unique element in the range.

PTS: 2 REF: 011018ia STA: A.G.3 TOP: Defining Functions

KEY: ordered pairs

167 ANS: 4

$$\frac{7}{12x} - \frac{y}{6x^2} = \frac{42x^2 - 12xy}{72x^3} = \frac{6x(7x - 2y)}{72x^3} = \frac{7x - 2y}{12x^2}$$

PTS: 2 REF: 061129ia STA: A.A.17 TOP: Addition and Subtraction of Rationals

168 ANS: 2

PTS: 2

REF: 011119ia

STA: A.A.29

TOP: Set Theory

169 ANS:

$$24,435.19. \quad 30000(.95)^4 \approx 24435.19$$

PTS: 4 REF: 011138ia STA: A.A.9 TOP: Exponential Functions

170 ANS: 4

$$\frac{2 + 3 + 0 + 1 + 3 + 2 + 4 + 0 + 2 + 3}{10} = \frac{20}{10} = 2 \quad \frac{x}{10} = 2 + 0.5$$

$$x = 25$$

PTS: 2 REF: 081020ia STA: A.S.16 TOP: Average Known with Missing Data

171 ANS: 2

PTS: 2

REF: 011022ia

STA: A.A.19

TOP: Factoring the Difference of Perfect Squares

172 ANS: 1

$$4y - 2x = 0$$

$$4(-1) - 2(-2) = 0$$

$$-4 + 4 = 0$$

PTS: 2 REF: 011021ia STA: A.A.39 TOP: Identifying Points on a Line

173 ANS: 4

$$\frac{150}{20} = \frac{x}{30}$$

$$20x = 4500$$

$$x = 225$$

PTS: 2 REF: 081101ia STA: A.N.5 TOP: Direct Variation

174 ANS: 1

$$15000(1.2)^{\frac{6}{3}} = 21,600. \quad 21,600 - 15,000 = 6,600$$

PTS: 2 REF: 061030ia STA: A.A.9 TOP: Exponential Functions

175 ANS: 1 PTS: 2 REF: 081015ia STA: A.G.5

TOP: Graphing Quadratic Functions

176 ANS: 2

$$\left| \frac{55.42 - 50.27}{55.42} \right| \approx 0.093$$

PTS: 2 REF: 081023ia STA: A.M.3 TOP: Error

KEY: area

177 ANS: 2 PTS: 2 REF: 011015ia STA: A.G.10

TOP: Identifying the Vertex of a Quadratic Given Graph

178 ANS: 4 PTS: 2 REF: 061028ia STA: A.G.6

TOP: Linear Inequalities

179 ANS: 2 PTS: 2 REF: 081127ia STA: A.A.40

TOP: Systems of Linear Inequalities

180 ANS: 2 PTS: 2 REF: 061023ia STA: A.A.23

TOP: Transforming Formulas

181 ANS: 1

$$b = 2j + 4 \quad 2j + 4 = 31 - j$$

$$b + j = 31 \quad 3j = 27$$

$$b = 31 - j \quad j = 9$$

PTS: 2 REF: 081119ia STA: A.A.7 TOP: Writing Linear Systems

182 ANS: 2

$$\sin 57 = \frac{x}{8}$$

$$x \approx 6.7$$

PTS: 2 REF: 061108ia STA: A.A.44 TOP: Using Trigonometry to Find a Side

183 ANS: 2

$$m = \frac{5-3}{8-1} = \frac{2}{7} \quad y - y_1 = m(x - x_1)$$

$$y - 5 = \frac{2}{7}(x - 8)$$

PTS: 2 REF: 081029ia STA: A.A.35 TOP: Writing Linear Equations

184 ANS: 3

$$\frac{x}{3} + \frac{x+1}{2} = x$$

$$\frac{2x + 3(x+1)}{6} = x$$

$$5x + 3 = 6x$$

$$3 = x$$

PTS: 2 REF: 061019ia STA: A.A.25

TOP: Solving Equations with Fractional Expressions

185 ANS:

$$y = \frac{3}{4}x + 10. \quad y = mx + b$$

$$4 = \frac{3}{4}(-8) + b$$

$$4 = -6 + b$$

$$10 = b$$

PTS: 3 REF: 011134ia STA: A.A.34 TOP: Writing Linear Equations

186 ANS:

Hat A, add 1 not green to Hat A, add 11 green to Hat B, and add none to Hat C.

PTS: 4 REF: 081038ia STA: A.S.22 TOP: Theoretical Probability

187 ANS: 4

$$\frac{ey}{n} + k = t$$

$$\frac{ey}{n} = t - k$$

$$y = \frac{n(t-k)}{e}$$

PTS: 2 REF: 011125ia STA: A.A.23 TOP: Transforming Formulas

188 ANS: 1

$$\sin x = \frac{\text{opposite}}{\text{hypotenuse}} = \frac{28}{53}$$

PTS: 2 REF: 011109ia STA: A.A.42 TOP: Trigonometric Ratios

189 ANS:

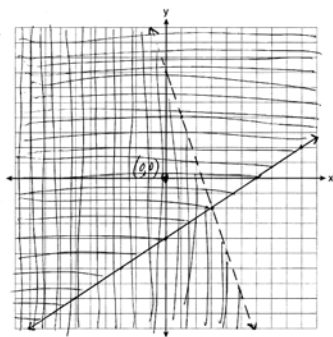

PTS: 4 REF: 061139ia STA: A.G.7 TOP: Systems of Linear Inequalities

190 ANS:

$$\frac{4}{12} \times \frac{2}{11} \times \frac{1}{10} = \frac{8}{1320} \quad \frac{6}{12} \times \frac{5}{11} \times \frac{4}{10} + \frac{4}{12} \times \frac{3}{11} \times \frac{2}{10} = \frac{120}{1320} + \frac{24}{1320} = \frac{144}{1320}$$

PTS: 4 REF: 081137ia STA: A.S.23 TOP: Theoretical Probability

KEY: dependent events

191 ANS:

$$bc + ac = ab$$

$$c(b + a) = ab$$

$$c = \frac{ab}{b+a}$$

PTS: 2 REF: 081131ia STA: A.A.23 TOP: Transforming Formulas

192 ANS: 4

$$6\sqrt{50} + 6\sqrt{2} = 6\sqrt{25 \cdot 2} + 6\sqrt{2} = 30\sqrt{2} + 6\sqrt{2} = 36\sqrt{2}$$

PTS: 2 REF: 011024ia STA: A.N.3 TOP: Operations with Radicals

KEY: addition

193 ANS: 3

$$P(S) \cdot P(M) = P(S \text{ and } M)$$

$$\frac{3}{5} \cdot P(M) = \frac{3}{10}$$

$$P(M) = \frac{1}{2}$$

PTS: 2 REF: 081024ia STA: A.S.23 TOP: Theoretical Probability

KEY: independent events

194 ANS: 2 PTS: 2 REF: 081106ia STA: A.S.6

TOP: Box-and-Whisker Plots

195 ANS: 1 PTS: 2 REF: 011004ia STA: A.A.31

TOP: Set Theory

- 196 ANS: 2
 $\sqrt{5^2 + 7^2} \approx 8.6$
- PTS: 2 REF: 081004ia STA: A.A.45 TOP: Pythagorean Theorem
- 197 ANS: 1 PTS: 2 REF: 011001ia STA: A.S.6
 TOP: Box-and-Whisker Plots
- 198 ANS: 4 PTS: 2 REF: 061018ia STA: A.A.12
 TOP: Division of Powers
- 199 ANS: 3
 $\frac{(12.3 \times 11.9) - (12.2 \times 11.8)}{12.3 \times 11.9} \approx 0.0165$
- PTS: 2 REF: 061120ia STA: A.M.3 TOP: Error
 KEY: area
- 200 ANS:
 $x = 1; (1, -5)$
- PTS: 2 REF: 061133ia STA: A.G.10
 TOP: Identifying the Vertex of a Quadratic Given Graph
- 201 ANS: 4 PTS: 2 REF: 011102ia STA: A.G.9
 TOP: Quadratic-Linear Systems
- 202 ANS:
 $\frac{x^2 - 5x - 24}{x - 8} = \frac{(x - 8)(x + 3)}{x - 8} = x + 3$
- PTS: 2 REF: 061131ia STA: A.A.16 TOP: Rational Expressions
 KEY: $a > 0$
- 203 ANS: 3
 $m = \frac{6 - 4}{3 - (-2)} = \frac{2}{5}$
- PTS: 2 REF: 061110ia STA: A.A.33 TOP: Slope
- 204 ANS: 4
 $2x - 3y = 9$
 $2(0) - 3(-3) = 9$
 $0 + 9 = 9$
- PTS: 2 REF: 081016ia STA: A.A.39 TOP: Identifying Points on a Line
- 205 ANS: 2 PTS: 2 REF: 061127ia STA: A.N.4
 TOP: Operations with Scientific Notation
- 206 ANS:
 (1) Distributive; (2) Commutative
- PTS: 2 REF: 061132ia STA: A.N.1 TOP: Identifying Properties
- 207 ANS: 3 PTS: 2 REF: 011103ia STA: A.S.12
 TOP: Scatter Plots

208 ANS: 1

$$2y - 2x = 10 \quad \text{axis of symmetry: } x = \frac{-b}{2a} = \frac{-2}{2(1)} = -1$$

$$2y = 2x + 10$$

$$y = x + 5$$

PTS: 2

REF: 081010ia

STA: A.G.9

TOP: Quadratic-Linear Systems

209 ANS:

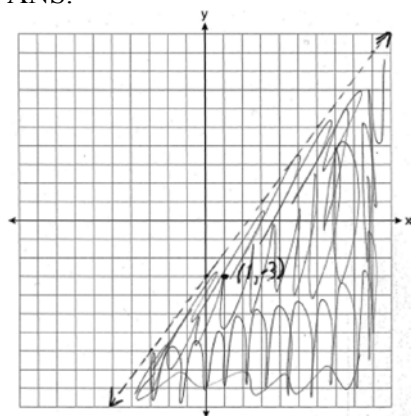

(1, -3) is in the solution set. $4(1) - 3(-3) > 9$

$$4 + 9 > 9$$

PTS: 4

REF: 011038ia

STA: A.G.6

TOP: Linear Inequalities

210 ANS: 2

$$m = \frac{5 - 2}{3 - (-2)} = \frac{3}{5}$$

PTS: 2

REF: 061004ia

STA: A.A.33

TOP: Slope

211 ANS: 3

$$3\sqrt{250} = 3\sqrt{25}\sqrt{10} = 15\sqrt{10}$$

PTS: 2

REF: 061106ia

STA: A.N.2

TOP: Simplifying Radicals

212 ANS:

$$\sin x = \frac{30}{50}$$

$$x = \sin^{-1} \frac{3}{5}$$

$$x \approx 37$$

PTS: 2

REF: 061033ia

STA: A.A.43

TOP: Using Trigonometry to Find an Angle

213 ANS:

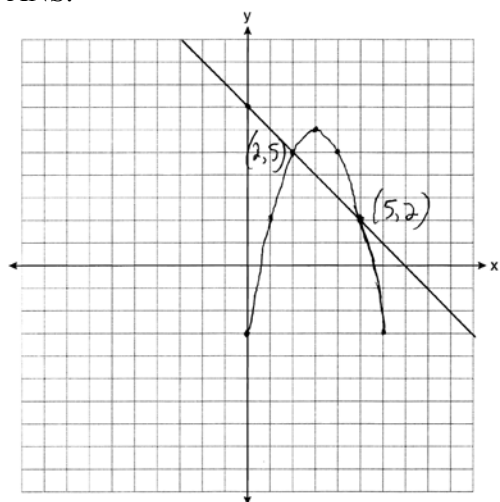

PTS: 4 REF: 081138ia STA: A.G.9 TOP: Quadratic-Linear Systems

214 ANS: 3

$$\frac{3+2+4+3}{20} = \frac{12}{20}$$

PTS: 2 REF: 011129ia STA: A.S.21 TOP: Experimental Probability

215 ANS:

$$41.8. \sin x = \frac{8}{12}$$

$$A \approx 41.8$$

PTS: 3 REF: 081135ia STA: A.A.43 TOP: Using Trigonometry to Find an Angle

216 ANS: 3

Frequency is not a variable.

PTS: 2 REF: 011014ia STA: A.S.2 TOP: Analysis of Data

217 ANS: 2

PTS: 2

TOP: Modeling Inequalities

REF: 061013ia

STA: A.G.3

KEY: graphs

218 ANS: 4

PTS: 2

REF: 081003ia

STA: A.A.31

TOP: Set Theory

219 ANS: 2

PTS: 2

REF: 081108ia

STA: A.A.34

TOP: Writing Linear Equations

220 ANS: 1

PTS: 2

REF: 061105ia

STA: A.A.20

TOP: Factoring Polynomials

- 222 ANS: 3 PTS: 2 REF: 081001ia STA: A.S.7
TOP: Scatter Plots
- 223 ANS: 2
 $\tan B = \frac{\text{opposite}}{\text{adjacent}} = \frac{8}{15} = 0.5\bar{3}$
- PTS: 2 REF: 081026ia STA: A.A.42 TOP: Trigonometric Ratios
- 224 ANS: 4 PTS: 2 REF: 011025ia STA: A.A.17
TOP: Addition and Subtraction of Rationals
- 225 ANS:
80, 136 $V = lwh = 10 \cdot 2 \cdot 4 = 80$ $SA = 2lw + 2hw + 2lh = 2 \cdot 10 \cdot 2 + 2 \cdot 4 \cdot 2 + 2 \cdot 10 \cdot 4 = 136$
- PTS: 3 REF: 081035ia STA: A.G.2 TOP: Surface Area
- 226 ANS:
 $\frac{1375}{1600} \cdot \frac{40^2 - 15^2}{40^2} = \frac{1375}{1600}$
- PTS: 2 REF: 011132ia STA: A.S.20 TOP: Geometric Probability
- 227 ANS:
 $0.65x + 35 \leq 45$
 $0.65x \leq 10$
 $x \leq 15$
- PTS: 3 REF: 061135ia STA: A.A.6 TOP: Modeling Inequalities
- 228 ANS:
16. 12 feet equals 4 yards. $4 \times 4 = 16$.
- PTS: 2 REF: 011031ia STA: A.M.2 TOP: Conversions
KEY: dimensional analysis
- 229 ANS: 2 PTS: 2 REF: 061128ia STA: A.A.29
TOP: Set Theory
- 230 ANS: 4
 $\frac{x}{x+4} \div \frac{2x}{x^2-16} = \frac{x}{x+4} \cdot \frac{x^2-16}{2x} = \frac{1}{x+4} \cdot \frac{(x+4)(x-4)}{2} = \frac{x-4}{2}$
- PTS: 2 REF: 081130ia STA: A.A.18 TOP: Multiplication and Division of Rationals
KEY: division
- 231 ANS: 1
 $1P + 2C = 5$
 $1P + 4C = 6$
 $2C = 1$
 $C = 0.5$
- PTS: 2 REF: 011003ia STA: A.A.7 TOP: Writing Linear Systems

232 ANS: 2

$$20000(.88)^3 = 13629.44$$

PTS: 2

REF: 061124ia

STA: A.A.9

TOP: Exponential Functions

Integrated Algebra Regents at Random Answer Section

233 ANS: 1

$$x^2 + 7x + 10 = 0$$

$$(x + 5)(x + 2) = 0$$

$$x = -5 \text{ or } -2$$

PTS: 2

REF: 080918ia

STA: A.A.15

TOP: Undefined Rationals

234 ANS: 4

Let x = youngest brother and $x + 4$ = oldest brother. $3x - (x + 4) = 48$.

$$2x - 4 = 48$$

$$x = 26$$

PTS: 2

REF: 080928ia

STA: A.A.6

TOP: Modeling Equations

235 ANS: 2

$$l(l - 5) = 24$$

$$l^2 - 5l - 24 = 0$$

$$(l - 8)(l + 3) = 0$$

$$l = 8$$

PTS: 2

REF: 080817ia

STA: A.A.8

TOP: Geometric Applications of Quadratics

236 ANS: 4

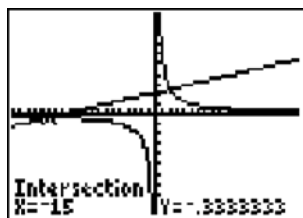

$$\frac{5}{x} = \frac{x + 13}{6}$$

$$x^2 + 13x = 30$$

$$x^2 + 13x - 30 = 0$$

$$(x + 15)(x - 2) = 0$$

$$x = -15 \text{ or } 2$$

PTS: 2

REF: 060826ia

STA: A.A.26

TOP: Solving Rationals

237 ANS: 4

PTS: 2

REF: 060916ia

STA: A.A.15

TOP: Undefined Rationals

238 ANS: 1

PTS: 2

REF: 080911ia

STA: A.A.36

TOP: Parallel and Perpendicular Lines

239 ANS: 4

PTS: 2

REF: 080825ia

STA: A.A.40

TOP: Systems of Linear Inequalities

240 ANS: 2

$$5\sqrt{20} = 5\sqrt{4}\sqrt{5} = 10\sqrt{5}$$

PTS: 2 REF: 080922ia STA: A.N.2 TOP: Simplifying Radicals

241 ANS:

$$30.4\%; \text{ no, } 23.3\%. \quad \frac{7.50 - 5.75}{5.75} = 30.4\%. \quad \frac{7.50 - 5.75}{7.50} = 23.3\%$$

PTS: 3 REF: 080935ia STA: A.N.5 TOP: Percents

242 ANS: 2

$$2x^2 + 10x - 12 = 2(x^2 + 5x - 6) = 2(x + 6)(x - 1)$$

PTS: 2 REF: 080806ia STA: A.A.20 TOP: Factoring Polynomials

243 ANS: 3 PTS: 2 REF: fall0706ia STA: A.A.19

TOP: Factoring the Difference of Perfect Squares

244 ANS:

$$60 - 42\sqrt{5}. \quad 3\sqrt{20}(2\sqrt{5} - 7) = 6\sqrt{100} - 21\sqrt{20} = 60 - 21\sqrt{4}\sqrt{5} = 60 - 42\sqrt{5}$$

PTS: 3 REF: 080834ia STA: A.N.3 TOP: Operations with Radicals

KEY: multiplication

245 ANS: 2 PTS: 2 REF: 010909ia STA: A.A.19

TOP: Factoring the Difference of Perfect Squares

246 ANS: 3

$$25 - 18 = 7$$

PTS: 2 REF: 060822ia STA: A.S.9

TOP: Frequency Histograms, Bar Graphs and Tables

247 ANS: 3

$$m = \frac{4 - 10}{3 - (-6)} = -\frac{2}{3}$$

PTS: 2 REF: fall0716ia STA: A.A.33 TOP: Slope

248 ANS: 3 PTS: 2 REF: 010910ia STA: A.A.35

TOP: Writing Linear Equations

249 ANS:

$$4x(x + 3)(x - 3). \quad 4x^3 - 36x = 4x(x^2 - 9) = 4x(x + 3)(x - 3)$$

PTS: 2 REF: 060932ia STA: A.A.19

TOP: Factoring the Difference of Perfect Squares

250 ANS: 2

If the car can travel 75 miles on 4 gallons, it can travel 300 miles on 16 gallons. $\frac{75}{4} = \frac{x}{16}$.

$$x = 300$$

PTS: 2 REF: 080807ia STA: A.G.4 TOP: Graphing Linear Functions

251 ANS:

Not all of the homework problems are equations. The first problem is an expression.

PTS: 2 REF: 080931ia STA: A.A.3 TOP: Expressions

252 ANS: 3

$$\sqrt{72} = \sqrt{36} \sqrt{2} = 6\sqrt{2}$$

PTS: 2 REF: 010920ia STA: A.N.2 TOP: Simplifying Radicals

253 ANS: 1 PTS: 2 REF: 080902ia STA: A.A.19

TOP: Factoring the Difference of Perfect Squares

254 ANS: 4 PTS: 2 REF: 010927ia STA: A.N.4

TOP: Operations with Scientific Notation

255 ANS: 1

$$m = \frac{4 - (-4)}{-5 - 15} = -\frac{2}{5}$$

PTS: 2 REF: 080915ia STA: A.A.33 TOP: Slope

256 ANS: 2

The median score, 10, is the vertical line in the center of the box.

PTS: 2 REF: fall0709ia STA: A.S.5 TOP: Box-and-Whisker Plots

257 ANS: 4

$$x^2 - 7x + 6 = 0$$

$$(x - 6)(x - 1) = 0$$

$$x = 6 \quad x = 1$$

PTS: 2 REF: 060902ia STA: A.A.28 TOP: Roots of Quadratics

258 ANS:

$$36 - 9\pi. \quad 15.6. \quad \text{Area of square} - \text{area of 4 quarter circles. } (3 + 3)^2 - 3^2\pi = 36 - 9\pi$$

PTS: 2 REF: 060832ia STA: A.G.1 TOP: Compositions of Polygons and Circles

KEY: area

259 ANS: 2

The volume of the cube using Ezra's measurements is $8 (2^3)$. The actual volume is $9.261 (2.1^3)$. The relative error

$$\text{is } \left| \frac{9.261 - 8}{9.261} \right| \approx 0.14.$$

PTS: 2 REF: 060928ia STA: A.M.3 TOP: Error

KEY: volume and surface area

260 ANS:

$$39, 63. \quad \tan 52 = \frac{50}{x}. \quad \sin 52 = \frac{50}{x}$$

$$x \approx 39 \quad x \approx 63$$

PTS: 4 REF: 060937ia STA: A.A.44 TOP: Using Trigonometry to Find a Side

261 ANS:

$$50, 1.5, 10. \frac{\text{distance}}{\text{time}} = \frac{60}{1.2} = 50. \frac{\text{distance}}{\text{time}} = \frac{60}{40} = 1.5. \text{ speed} \times \text{time} = 55 \times 2 = 110. 120 - 110 = 10$$

PTS: 3 REF: fall0734ia STA: A.M.1 TOP: Speed

262 ANS: 2

$$L + S = 47$$

$$L - S = 15$$

$$2L = 62$$

$$L = 31$$

PTS: 2 REF: 060912ia STA: A.A.7 TOP: Writing Linear Systems

263 ANS: 1 PTS: 2 REF: 060801ia STA: A.G.4

TOP: Families of Functions

264 ANS: 3 PTS: 2 REF: fall0705ia STA: A.N.1

TOP: Identifying Properties

265 ANS: 3

$$\frac{(2x^3)(8x^5)}{4x^6} = \frac{16x^8}{4x^6} = 4x^2$$

PTS: 2 REF: fall0703ia STA: A.A.12 TOP: Division of Powers

266 ANS: 4

$$V = \pi r^2 h = \pi \cdot 6^2 \cdot 15 \approx 1696.5$$

PTS: 2 REF: fall0712ia STA: A.G.2 TOP: Volume

267 ANS: 2 PTS: 2 REF: 060821ia STA: A.A.5

TOP: Modeling Inequalities

268 ANS:

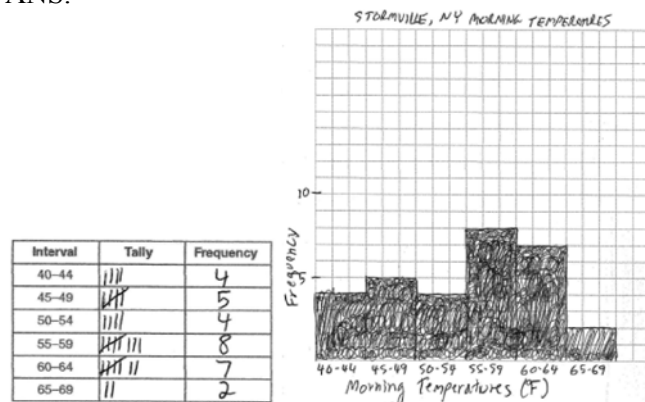

PTS: 4 REF: 060938ia STA: A.S.5

TOP: Frequency Histograms, Bar Graphs and Tables

KEY: frequency histograms

269 ANS: 2 PTS: 2 REF: 010916ia

STA: A.G.10

TOP: Identifying the Vertex of a Quadratic Given Graph

270 ANS: 3

$$5x + 2y = 48$$

$$3x + 2y = 32$$

$$2x = 16$$

$$x = 8$$

PTS: 2

REF: fall0708ia

STA: A.A.10

TOP: Solving Linear Systems

271 ANS:

$$(-2, 5). \quad 3x + 2y = 4 \quad 12x + 8y = 16. \quad 3x + 2y = 4$$

$$4x + 3y = 7 \quad 12x + 9y = 21 \quad 3x + 2(5) = 4$$

$$y = 5$$

$$3x = -6$$

$$x = -2$$

PTS: 4

REF: 010937ia

STA: A.A.10

TOP: Solving Linear Systems

272 ANS: 2

PTS: 2

REF: 060830ia

STA: A.A.9

TOP: Exponential Functions

273 ANS: 4

PTS: 2

REF: 010930ia

STA: A.G.3

TOP: Defining Functions

KEY: graphs

274 ANS:

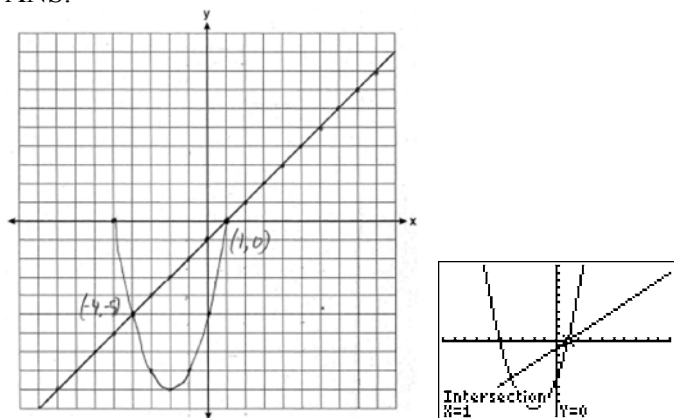

PTS: 4

REF: 080839ia

STA: A.G.9

TOP: Quadratic-Linear Systems

275 ANS: 1

$$0.07m + 19 \leq 29.50$$

$$0.07m \leq 10.50$$

$$m \leq 150$$

PTS: 2

REF: 010904ia

STA: A.A.6

TOP: Modeling Inequalities

276 ANS: 1

PTS: 2

REF: 080924ia

STA: A.G.1

TOP: Compositions of Polygons and Circles

KEY: perimeter

277 ANS:

$$10 + 2d \geq 75, 33. \quad 10 + 2d \geq 75$$

$$d \geq 32.5$$

PTS: 3

REF: 060834ia

STA: A.A.6

TOP: Modeling Inequalities

278 ANS: 3

The value of the third quartile is the last vertical line of the box.

PTS: 2

REF: 080818ia

STA: A.S.6

TOP: Box-and-Whisker Plots

279 ANS: 3

$$\cos 30 = \frac{x}{24}$$

$$x \approx 21$$

PTS: 2

REF: 010912ia

STA: A.A.44

TOP: Using Trigonometry to Find a Side

280 ANS: 4

PTS: 2

REF: 010908ia

STA: A.A.9

TOP: Exponential Functions

281 ANS: 3

$$3^2 + 5^2 = x^2$$

$$34 = x^2$$

$$\sqrt{34} = x$$

PTS: 2

REF: 060909ia

STA: A.A.45

TOP: Pythagorean Theorem

282 ANS: 1

PTS: 2

REF: 060811ia

STA: A.G.10

TOP: Identifying the Vertex of a Quadratic Given Graph

283 ANS: 2

PTS: 2

REF: 080901ia

STA: A.A.4

TOP: Modeling Equations

284 ANS: 4

$$\frac{(d \times 3) + (2 \times 2d)}{2 \times 3} = \frac{3d + 4d}{6} = \frac{7d}{6}$$

PTS: 2

REF: fall0727ia

STA: A.A.17

TOP: Addition and Subtraction of Rationals

285 ANS: 3

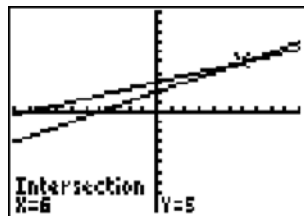

$$\frac{k+4}{2} = \frac{k+9}{3}$$

$$3(k+4) = 2(k+9)$$

$$3k + 12 = 2k + 18$$

$$k = 6$$

PTS: 2

REF: 010906ia

STA: A.A.26

TOP: Solving Rationals

286 ANS:

$$5,112. (12 \times 30 \times 16) - (6 \times 12 \times 9) = 5112$$

PTS: 2 REF: 080932ia STA: A.G.2 TOP: Volume

287 ANS: 2

$$\frac{3}{5}(x+2) = x-4$$

$$3(x+2) = 5(x-4)$$

$$3x+6 = 5x-20$$

$$26 = 2x$$

$$x = 13$$

PTS: 2 REF: 080909ia STA: A.A.25

TOP: Solving Equations with Fractional Expressions

288 ANS: 3

$$(3-1) \times 2 \times 3 = 12$$

PTS: 2 REF: 080905ia STA: A.N.7 TOP: Conditional Probability

289 ANS: 1

$$\frac{1}{8} \times \frac{1}{8} = \frac{1}{64}$$

PTS: 2 REF: 010928ia STA: A.S.23 TOP: Geometric Probability

290 ANS:

$$1,512, 1,551.25, 0.025. 36 \times 42 = 1512. 36.5 \times 42.5 = 1551.25. RE = \left| \frac{1512 - 1551.25}{1551.25} \right| \approx 0.025.$$

PTS: 3 REF: 010934ia STA: A.M.3 TOP: Error

KEY: area

291 ANS:

$$w(w+15) = 54, 3, 18. \quad w(w+15) = 54$$

$$w^2 + 15w - 54 = 0$$

$$(w+18)(w-3) = 0$$

$$w = 3$$

PTS: 4 REF: 060837ia STA: A.A.8 TOP: Geometric Applications of Quadratics

292 ANS: 4

$$\frac{25x-125}{x^2-25} = \frac{25(x-5)}{(x+5)(x-5)} = \frac{25}{x+5}$$

PTS: 2 REF: 080821ia STA: A.A.16 TOP: Rational Expressions

KEY: $a > 0$

293 ANS:

$$y = \frac{2}{5}x + 2. \quad m = \frac{4-0}{5-(-5)} = \frac{2}{5}. \quad y = mx + b$$

$$4 = \frac{2}{5}(5) + b$$

$$b = 2$$

PTS: 3 REF: 080836ia STA: A.A.35 TOP: Writing Linear Equations

294 ANS: 4

The transformation is a reflection in the x -axis.

PTS: 2 REF: fall0722ia STA: A.G.5 TOP: Graphing Absolute Value Functions

295 ANS: 2

$$\tan 32 = \frac{x}{25}$$

$$x \approx 15.6$$

PTS: 2 REF: 080914ia STA: A.A.44 TOP: Using Trigonometry to Find a Side

296 ANS: 3

The other situations are quantitative.

PTS: 2 REF: 060819ia STA: A.S.1 TOP: Analysis of Data

297 ANS: 3

$$35000(1 - 0.05)^4 \approx 28507.72$$

PTS: 2 REF: fall0719ia STA: A.A.9 TOP: Exponential Functions

298 ANS: 4

TOP: Defining Functions

PTS: 2 REF: fall0730ia
KEY: graphs

299 ANS: 4

$$A = lw = (3w - 7)(w) = 3w^2 - 7w$$

PTS: 2 REF: 010924ia STA: A.A.1 TOP: Expressions

300 ANS: 3

$$b = 42 - r \quad r = 2b + 3$$

$$r = 2b + 3 \quad r = 2(42 - r) + 3$$

$$r = 84 - 2r + 3$$

$$3r = 87$$

$$r = 29$$

PTS: 2 REF: 060812ia STA: A.A.7 TOP: Writing Linear Systems

301 ANS:

315,000, 180,000, the median better represents value since it is closer to more prices than the mean.

PTS: 4 REF: 060839ia STA: A.S.4
TOP: Frequency Histograms, Bar Graphs and Tables

302 ANS: 4

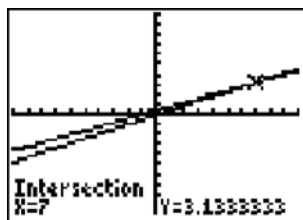

$$\frac{2x}{5} + \frac{1}{3} = \frac{7x-2}{15}$$

$$\frac{(2x \times 3) + (5 \times 1)}{5 \times 3} = \frac{7x-2}{15}$$

$$\frac{6x+5}{15} = \frac{7x-2}{15}$$

$$6x+5 = 7x-2$$

$$x = 7$$

PTS: 2 REF: 080820ia STA: A.A.25

TOP: Solving Equations with Fractional Expressions

303 ANS:

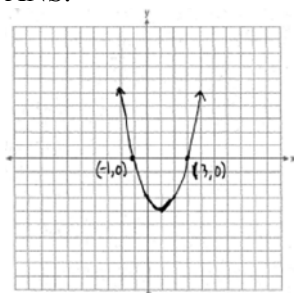

PTS: 3 REF: 060836ia STA: A.G.8 TOP: Solving Quadratics by Graphing

304 ANS:

618.45, 613.44, 0.008. $21.7 \times 28.5 = 618.45$. $21.6 \times 28.4 = 613.44$. $\left| \frac{618.45 - 613.44}{613.44} \right| \approx 0.008$. An error of less than 1% would seem to be insignificant.

PTS: 4 REF: 060838ia STA: A.M.3 TOP: Error

KEY: area

305 ANS: 3

$$x^2 - 10x + 21 = 0$$

$$(x-7)(x-3) = 0$$

$$x = 7 \quad x = 3$$

PTS: 2 REF: 010914ia STA: A.A.28 TOP: Roots of Quadratics

306 ANS: 2 PTS: 2 REF: 080916ia STA: A.G.8

TOP: Solving Quadratics by Graphing

307 ANS: 3

$$3ax + b = c$$

$$3ax = c - b$$

$$x = \frac{c - b}{3a}$$

PTS: 2

REF: 080808ia

STA: A.A.23

TOP: Transforming Formulas

308 ANS:

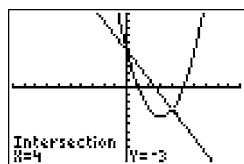
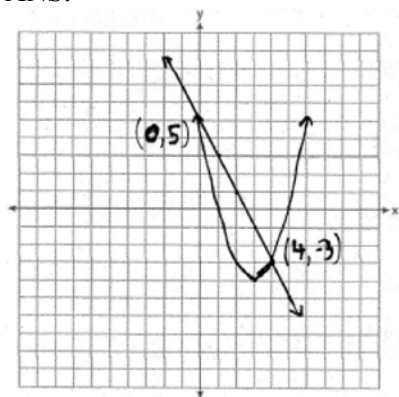

X	Y1	Y2
0	5	5
1	0	0
2	-1	-1
3	0	0
4	5	5
X=0		

PTS: 4

REF: fall0738ia

STA: A.G.9

TOP: Quadratic-Linear Systems

309 ANS: 2

$$x + 2y = 9$$

$$x - y = 3$$

$$3y = 6$$

$$y = 2$$

PTS: 2

REF: 060925ia

STA: A.A.10

TOP: Solving Linear Systems

310 ANS: 3

An element of the domain, 1, is paired with two different elements of the range, 3 and 7.

PTS: 2

REF: 080919ia

STA: A.G.3

TOP: Defining Functions

KEY: ordered pairs

311 ANS: 1

PTS: 2

REF: 080803ia

STA: A.A.4

TOP: Modeling Inequalities

312 ANS:

$\frac{38}{\pi}, 2, V = \pi r^2 h$. $\frac{36}{\left(\frac{38}{\pi}\right)} \approx 2.97$. Three cans will not fit. The maximum number is 2.

$$342 = \pi \left(\frac{6}{2}\right)^2 h$$

$$\frac{342}{9\pi} = h$$

$$\frac{38}{\pi} = h$$

PTS: 3

REF: 010936ia

STA: A.G.2

TOP: Volume

313 ANS:

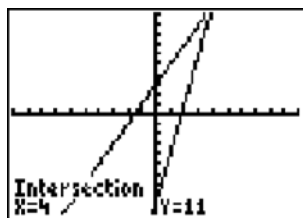

4. $3 + 2g = 5g - 9$

$$12 = 3g$$

$$g = 4$$

PTS: 2

REF: fall0732ia

STA: A.A.22

TOP: Solving Equations

314 ANS: 4

$$SA = 2lw + 2hw + 2lh = 2(3)(1.5) + 2(2)(1.5) + 2(3)(2) = 27$$

PTS: 2

REF: 060827ia

STA: A.G.2

TOP: Surface Area

315 ANS: 3

The number of correct answers on a test causes the test score.

PTS: 2

REF: 080908ia

STA: A.S.13

TOP: Analysis of Data

316 ANS: 3

PTS: 2

REF: fall0702ia

STA: A.S.23

TOP: Theoretical Probability

KEY: mutually exclusive events

317 ANS: 2

The events are not mutually exclusive: $P(\text{prime}) = \frac{3}{6}$, $P(\text{even}) = \frac{3}{6}$, $P(\text{prime AND even}) = \frac{1}{6}$

$$P(\text{prime OR even}) = \frac{3}{6} + \frac{3}{6} - \frac{1}{6} = \frac{5}{6}$$

PTS: 2

REF: 080830ia

STA: A.S.23

TOP: Theoretical Probability

KEY: not mutually exclusive events

318 ANS: 4

$$\frac{2^6}{2^1} = 2^5$$

PTS: 2

REF: 060813ia

STA: A.A.12

TOP: Division of Powers

- 319 ANS: 3 PTS: 2 REF: 060808ia STA: A.N.8
TOP: Permutations
- 320 ANS: 1
 $y = mx + b$
 $-6 = (-3)(4) + b$
 $b = 6$
- PTS: 2 REF: 060922ia STA: A.A.34 TOP: Writing Linear Equations
- 321 ANS: 3
The other situations are quantitative.
- PTS: 2 REF: 060905ia STA: A.S.1 TOP: Analysis of Data
- 322 ANS: 3
 $a + ar = b + r$
 $a(1 + r) = b + r$
 $a = \frac{b + r}{1 + r}$
- PTS: 2 REF: 060913ia STA: A.A.23 TOP: Transforming Formulas
- 323 ANS: 1
 $\frac{4x}{x-1} \cdot \frac{x^2-1}{3x+3} = \frac{4x}{x-1} \cdot \frac{(x+1)(x-1)}{3(x+1)} = \frac{4x}{3}$
- PTS: 2 REF: 080826ia STA: A.A.18 TOP: Multiplication and Division of Rationals
KEY: multiplication
- 324 ANS: 1
A rooster crows before sunrise, not because of the sun.
- PTS: 2 REF: fall0707ia STA: A.S.14 TOP: Analysis of Data
- 325 ANS: 2 PTS: 2 REF: 010915ia STA: A.A.5
TOP: Modeling Equations
- 326 ANS:
50. $12 + 10 + 12 + \frac{1}{2}(10\pi) \approx 50$
- PTS: 2 REF: 010931ia STA: A.G.1 TOP: Compositions of Polygons and Circles
KEY: perimeter
- 327 ANS: 4
 $-2(x-5) < 4$
 $-2x + 10 < 4$
 $-2x < -6$
 $x > 3$
- PTS: 2 REF: 080913ia STA: A.A.21 TOP: Interpreting Solutions

328 ANS: 1

$$\left| \frac{289 - 282}{289} \right| \approx 0.024$$

PTS: 2 REF: 080828ia STA: A.M.3 TOP: Error
KEY: volume and surface area

329 ANS:

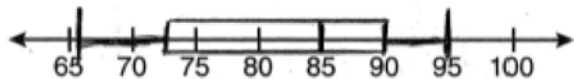

PTS: 4 REF: 080939ia STA: A.S.5 TOP: Box-and-Whisker Plots

330 ANS: 4

$$y = mx + b$$

$$-1 = (2)(3) + b$$

$$b = -7$$

PTS: 2 REF: 080927ia STA: A.A.34 TOP: Writing Linear Equations

331 ANS: 1 PTS: 2 REF: 060920ia STA: A.G.6

TOP: Linear Inequalities

332 ANS:

$$30\sqrt{2} \cdot 5\sqrt{72} = 5\sqrt{36} \sqrt{2} = 30\sqrt{2}$$

PTS: 2 REF: fall0731ia STA: A.N.2 TOP: Simplifying Radicals

333 ANS:

225000, 175000, the median better represents the value since it is closer to more values than the mean.

PTS: 4 REF: fall0737ia STA: A.S.4

TOP: Frequency Histograms, Bar Graphs and Tables

334 ANS:

$$d = 6.25h, 250. \quad d = 6.25(40) = 250$$

PTS: 2 REF: 010933ia STA: A.N.5 TOP: Direct Variation

335 ANS: 1 PTS: 2 REF: 010905ia STA: A.G.4

TOP: Families of Functions

336 ANS: 1

The slope of both is -4 .

PTS: 2 REF: 060814ia STA: A.A.38 TOP: Parallel and Perpendicular Lines

337 ANS:

(H,F,M), (H,F,J), (H,F,S), (H,A,M), (H,A,J), (H,A,S), (C,F,M), (C,F,J), (C,F,S), (C,A,M), (C,A,J), (C,A,S), (T,F,M), (T,F,J), (T,F,S), (T,A,M), (T,A,J), (T,A,S). There are 18 different kids' meals, 12 do not include juice and 6 include chicken nuggets.

PTS: 4 REF: 010939ia STA: A.S.19 TOP: Sample Space

- 338 ANS: 3 PTS: 2 REF: fall0710ia STA: A.A.31
TOP: Set Theory
- 339 ANS: 1
 $30^2 + 40^2 = c^2$. 30, 40, 50 is a multiple of 3, 4, 5.
 $2500 = c^2$
 $50 = c$
- PTS: 2 REF: fall0711ia STA: A.A.45 TOP: Pythagorean Theorem
- 340 ANS: 3
The value of the upper quartile is the last vertical line of the box.
- PTS: 2 REF: 060915ia STA: A.S.6 TOP: Box-and-Whisker Plots
- 341 ANS: 2
 $m = \frac{5-3}{2-7} = -\frac{2}{5}$
- PTS: 2 REF: 010913ia STA: A.A.33 TOP: Slope
- 342 ANS:
(S,S), (S,K), **(S,D)**, (K,S), (K,K), **(K,D)**, **(D,S)**, **(D,K)**, (D,D), $\frac{4}{9}$
- PTS: 3 REF: fall0736ia STA: A.S.19 TOP: Sample Space
- 343 ANS: 4 PTS: 2 REF: 010929ia STA: A.S.6
TOP: Box-and-Whisker Plots
- 344 ANS: 2
 $\left| \frac{149.6 - 174.2}{149.6} \right| \approx 0.1644$
- PTS: 2 REF: 080926ia STA: A.M.3 TOP: Error
KEY: area
- 345 ANS:
 $\frac{1}{8}$. After the English and social studies books are taken, 8 books are left and 1 is an English book.
- PTS: 2 REF: 060933ia STA: A.S.18 TOP: Conditional Probability
- 346 ANS: 3 PTS: 2 REF: 080925ia STA: A.G.4
TOP: Identifying the Equation of a Graph

347 ANS:

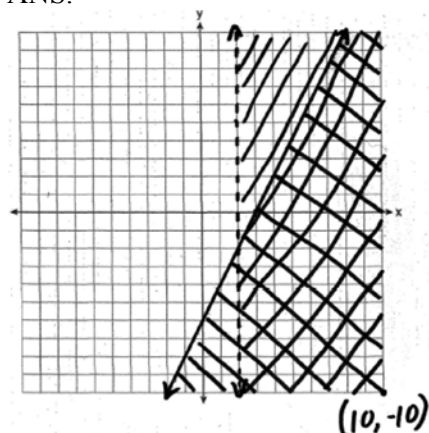

PTS: 4 REF: 010938ia STA: A.G.7 TOP: Systems of Linear Inequalities

348 ANS:

$$\frac{x-7}{3x} \cdot \frac{2x^2-8x-42}{6x^2} \div \frac{x^2-9}{x^2-3x} = \frac{2(x^2-4x-21)}{6x^2} \cdot \frac{x(x-3)}{(x+3)(x-3)} = \frac{(x-7)(x+3)}{3x} \cdot \frac{1}{x+3} = \frac{x-7}{3x}$$

PTS: 4 REF: 080937ia STA: A.A.18 TOP: Multiplication and Division of Rationals

KEY: division

349 ANS: 3

$$|-5(5) + 12| = |-13| = 13$$

PTS: 2 REF: 080923ia STA: A.N.6 TOP: Evaluating Expressions

350 ANS: 2

$$3c + 4m = 12.50$$

$$3c + 2m = 8.50$$

$$2m = 4.00$$

$$m = 2.00$$

PTS: 2 REF: 060806ia STA: A.A.7 TOP: Writing Linear Systems

351 ANS: 1

$$\frac{\sqrt{32}}{4} = \frac{\sqrt{16} \sqrt{2}}{4} = \sqrt{2}$$

PTS: 2 REF: 060828ia STA: A.N.2 TOP: Simplifying Radicals

352 ANS: 4 PTS: 2 REF: fall0704ia STA: A.A.29

TOP: Set Theory

353 ANS:

$$x = \frac{-b}{2a} = \frac{-(-8)}{2(-2)} = -2$$

$$y = -2(-2)^2 - 8(-2) + 3 = 11$$

PTS: 3 REF: 080934ia STA: A.A.41
TOP: Identifying the Vertex of a Quadratic Given Equation

354 ANS: 4

The mean is $80.\bar{6}$, the median is 84.5 and the mode is 87.

PTS: 2 REF: 010907ia STA: A.S.4 TOP: Central Tendency

355 ANS: 4

$$w(w + 5) = 36$$

$$w^2 + 5w - 36 = 0$$

PTS: 2 REF: fall0726ia STA: A.A.5 TOP: Modeling Equations

356 ANS: 1

Everyone eats, can shop in malls and wear clothes. People who work in a sporting goods store probably watch more sports television than most.

PTS: 2 REF: 010923ia STA: A.S.3 TOP: Analysis of Data

357 ANS: 3 PTS: 2 REF: 060926ia STA: A.N.1

TOP: Properties of Reals

358 ANS: 3 PTS: 2 REF: 060919ia STA: A.G.3

TOP: Defining Functions KEY: graphs

359 ANS:

Greg's rate of 5.5 is faster than Dave's rate of 5.3. $\frac{\text{distance}}{\text{time}} = \frac{11}{2} = 5.5$. $\frac{16}{3} = 5.\bar{3}$

PTS: 3 REF: 080936ia STA: A.M.1 TOP: Speed

360 ANS:

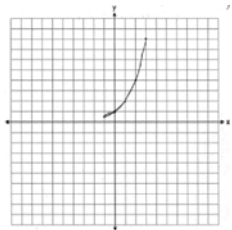

The graph will never intersect the x -axis as $2^x > 0$ for all values of x .

PTS: 3 REF: 080835ia STA: A.G.4 TOP: Graphing Exponential Functions

361 ANS: 3 PTS: 2 REF: 080819ia STA: A.A.13
TOP: Addition and Subtraction of Polynomials KEY: subtraction

362 ANS: 4

$$25(x - 3) = 25x - 75$$

PTS: 2 REF: 060823ia STA: A.A.1 TOP: Expressions

- 363 ANS: 4 PTS: 2 REF: 080827ia STA: A.A.12
TOP: Powers of Powers
- 364 ANS: 4 PTS: 2 REF: fall0715ia STA: A.A.5
TOP: Modeling Inequalities
- 365 ANS: 2 PTS: 2 REF: 080823ia STA: A.A.32
TOP: Slope
- 366 ANS: 4
 $\frac{5}{45} = \frac{8}{x}$
 $5x = 360$
 $x = 72$
- PTS: 2 REF: 060901ia STA: A.M.1 TOP: Speed
- 367 ANS: 1 PTS: 2 REF: 060807ia STA: A.A.13
TOP: Multiplication of Polynomials
- 368 ANS: 3 PTS: 2 REF: 080907ia STA: A.S.20
TOP: Geometric Probability
- 369 ANS: 2 PTS: 2 REF: 080802ia STA: A.N.1
TOP: Identifying Properties
- 370 ANS: 2
The slope of the inequality is $-\frac{1}{2}$.
- PTS: 2 REF: fall0720ia STA: A.G.6 TOP: Linear Inequalities
- 371 ANS: 2
The set of integers greater than -2 and less than 6 is $\{-1, 0, 1, 2, 3, 4, 5\}$. The subset of this set that is the positive factors of 5 is $\{1, 5\}$. The complement of this subset is $\{-1, 0, 2, 3, 4\}$.
- PTS: 2 REF: 060818ia STA: A.A.30 TOP: Set Theory
- 372 ANS:
 $\frac{3k^2m^6}{4}$
- PTS: 2 REF: 010932ia STA: A.A.12 TOP: Division of Powers
- 373 ANS:
7. $15x + 22 \geq 120$
 $x \geq 6.\overline{53}$
- PTS: 3 REF: fall0735ia STA: A.A.6 TOP: Modeling Inequalities
- 374 ANS: 4
 $\frac{x^2 - 1}{x + 1} \cdot \frac{x + 3}{3x - 3} = \frac{(x + 1)(x - 1)}{x + 1} \cdot \frac{x + 3}{3(x - 1)} = \frac{x + 3}{3}$
- PTS: 2 REF: 060815ia STA: A.A.18 TOP: Multiplication and Division of Rationals
KEY: multiplication

375 ANS: 1

$$so = f + 60 \quad j = 2f - 50 \quad se = 3f. \quad f + (f + 60) + (2f - 50) + 3f = 1424$$

$$7f + 10 = 1424$$

$$f = 202$$

PTS: 2 REF: 060917ia STA: A.A.7 TOP: Writing Linear Systems

376 ANS: 3 PTS: 2 REF: 011104ia STA: A.A.1

TOP: Expressions

377 ANS: 4 PTS: 2 REF: fall0729ia STA: A.A.2

TOP: Expressions

378 ANS: 2 PTS: 2 REF: 060904ia STA: A.A.1

TOP: Expressions

379 ANS: 2

$$\sin A = \frac{8}{12}$$

$$A \approx 42$$

PTS: 2 REF: 060816ia STA: A.A.43 TOP: Using Trigonometry to Find an Angle

380 ANS: 4 PTS: 2 REF: 060906ia STA: A.A.4

TOP: Modeling Inequalities

381 ANS: 2

$$\sqrt{32} = \sqrt{16} \sqrt{2} = 4\sqrt{2}$$

PTS: 2 REF: 060910ia STA: A.N.2 TOP: Simplifying Radicals

382 ANS: 3

$$m = \frac{1 - (-4)}{-6 - 4} = -\frac{1}{2}$$

PTS: 2 REF: 060820ia STA: A.A.33 TOP: Slope

383 ANS: 4 PTS: 2 REF: 060930ia STA: A.A.29

TOP: Set Theory

384 ANS: 2 PTS: 2 REF: 080810ia STA: A.A.36

TOP: Parallel and Perpendicular Lines

385 ANS:

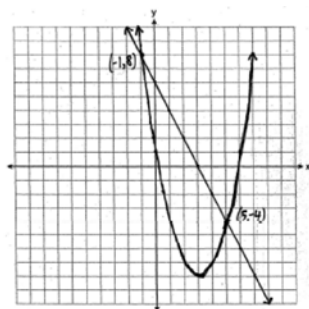

PTS: 4 REF: 060939ia STA: A.G.9 TOP: Quadratic-Linear Systems

386 ANS: 4 PTS: 2 REF: 060805ia STA: A.S.12
TOP: Scatter Plots

387 ANS: 3 PTS: 2 REF: 060825ia STA: A.A.45
TOP: Pythagorean Theorem

388 ANS:

$$\frac{3}{4x-8} \cdot \frac{3x+6}{4x+12} \div \frac{x^2-4}{x+3} = \frac{3(x+2)}{4(x+3)} \cdot \frac{x+3}{(x+2)(x-2)} = \frac{3}{4(x-2)}$$

PTS: 3 REF: 010935ia STA: A.A.18 TOP: Multiplication and Division of Rationals
KEY: division

389 ANS: 4

$$P(O) = \frac{3}{6}, P(E) = \frac{3}{6}, P(< 6) = \frac{5}{6}, P(> 4) = \frac{2}{6}$$

PTS: 2 REF: 010903ia STA: A.S.22 TOP: Theoretical Probability

390 ANS:
33.4. Serena needs 24 (9 + 6 + 9) feet of fencing to surround the rectangular portion of the garden. The length of the fencing needed for the semicircular portion of the garden is $\frac{1}{2}\pi d = 3\pi \approx 9.4$ feet.

PTS: 2 REF: fall0733ia STA: A.G.1 TOP: Compositions of Polygons and Circles
KEY: perimeter

391 ANS: 3
mean = 6, median = 6 and mode = 7

PTS: 2 REF: 080804ia STA: A.S.4 TOP: Central Tendency

392 ANS:

$$111.25 \cdot \frac{\text{distance}}{\text{time}} = \frac{89}{0.8} = 111.25$$

PTS: 2 REF: 080831ia STA: A.M.1 TOP: Speed

393 ANS:
60. ${}_5P_3 = 60$

PTS: 2 REF: 060931ia STA: A.N.8 TOP: Permutations

394 ANS: 2 PTS: 2 REF: fall0701ia STA: A.S.7
TOP: Scatter Plots

395 ANS: 1 PTS: 2 REF: fall0728ia STA: A.A.15
TOP: Undefined Rationals

396 ANS: 2 PTS: 2 REF: fall0725ia STA: A.N.4
TOP: Operations with Scientific Notation

397 ANS: 1

$$x = \frac{-b}{2a} = \frac{-(-16)}{2(1)} = 8. \quad y = (8)^2 - 16(8) + 63 = -1$$

PTS: 2 REF: 060918ia STA: A.A.41
TOP: Identifying the Vertex of a Quadratic Given Equation

- 398 ANS: 2 PTS: 2 REF: 060923ia STA: A.A.13
TOP: Addition and Subtraction of Polynomials KEY: subtraction
- 399 ANS: 4
 $P(G \text{ or } W) = \frac{4}{8}, P(G \text{ or } B) = \frac{3}{8}, P(Y \text{ or } B) = \frac{4}{8}, P(Y \text{ or } G) = \frac{5}{8}$
- PTS: 2 REF: 060802ia STA: A.S.22 TOP: Geometric Probability
- 400 ANS: 4 PTS: 2 REF: 060927ia STA: A.N.4
TOP: Operations with Scientific Notation
- 401 ANS: 2
 $\frac{3}{2x} + \frac{4}{3x} = \frac{9x + 8x}{6x^2} = \frac{17x}{6x^2} = \frac{17}{6x}$
- PTS: 2 REF: 080917ia STA: A.A.17 TOP: Addition and Subtraction of Rationals
- 402 ANS: 2
 $x^2 - 5x + 6 = 0$
 $(x - 3)(x - 2) = 0$
 $x = 3 \quad x = 2$
- PTS: 2 REF: 081120ia STA: A.A.28 TOP: Roots of Quadratics
- 403 ANS: 1
The slope of $y = 3 - 2x$ is -2 . Using $m = -\frac{A}{B}$, the slope of $4x + 2y = 5$ is $-\frac{4}{2} = -2$.
- PTS: 2 REF: 010926ia STA: A.A.38 TOP: Parallel and Perpendicular Lines
- 404 ANS: 2
 $1.5^3 = 3.375$
- PTS: 2 REF: 060809ia STA: A.G.2 TOP: Volume
- 405 ANS: 2
 $s + o = 126. \quad s + 2s = 126$
 $o = 2s \quad s = 42$
- PTS: 2 REF: 080811ia STA: A.A.7 TOP: Writing Linear Systems
- 406 ANS:
 $0 \leq t \leq 40$
- PTS: 2 REF: 060833ia STA: A.A.31 TOP: Set Theory
- 407 ANS:
 $\frac{3}{8} \cdot P(s_1 < 4) \times P(s_2 = \text{back}) = \frac{3}{4} \times \frac{1}{2} = \frac{3}{8}$
- PTS: 2 REF: 080832ia STA: A.S.23 TOP: Geometric Probability

408 ANS: 3
 $x^2 - 6x = 0$
 $x(x - 6) = 0$
 $x = 0$ $x = 6$

PTS: 2 REF: 080921ia STA: A.A.27 TOP: Solving Quadratics by Factoring

409 ANS: 3 PTS: 2 REF: 060924ia STA: A.G.8
 TOP: Solving Quadratics by Graphing

410 ANS: 1 PTS: 2 REF: fall0723ia STA: A.M.3
 TOP: Error KEY: area

411 ANS: 4
 $-4x + 2 > 10$
 $-4x > 8$
 $x < -2$

PTS: 2 REF: 080805ia STA: A.A.21 TOP: Interpreting Solutions

412 ANS:

Interval	Tally	Frequency
0-1		3
2-3		7
4-5		7
6-7		3

Interval	Cumulative Frequency
0-1	3
0-3	10
0-5	17
0-7	20

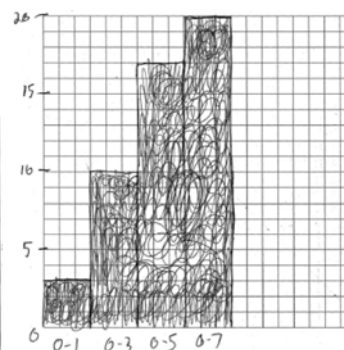

PTS: 4 REF: 080838ia STA: A.S.5

TOP: Frequency Histograms, Bar Graphs and Tables

KEY: cumulative frequency histograms

413 ANS: 2
 $\sin U = \frac{\text{opposite}}{\text{hypotenuse}} = \frac{15}{17}$

PTS: 2 REF: 010919ia STA: A.A.42 TOP: Trigonometric Ratios

414 ANS: 1
 $\frac{2}{x} - 3 = \frac{26}{x}$
 $-3 = \frac{24}{x}$
 $x = -8$

PTS: 2 REF: 010918ia STA: A.A.26 TOP: Solving Rationals

415 ANS:
 $\{1,2,4,5,9,10,12\}$

PTS: 2 REF: 080833ia STA: A.A.30 TOP: Set Theory

416 ANS: 2

$$\frac{2x^2 - 12x}{x - 6} = \frac{2x(x - 6)}{x - 6} = 2x$$

PTS: 2 REF: 060824ia STA: A.A.16 TOP: Rational Expressions

KEY: $a > 0$

417 ANS: 4

$$A = \{2, 4, 6, 8, 10, 12, 14, 16, 18, 20\}$$

PTS: 2 REF: 080912ia STA: A.A.30 TOP: Set Theory

418 ANS:

$$\text{Ann's. } \frac{225}{15} = 15 \text{ mpg is greater than } \frac{290}{23.2} = 12.5 \text{ mpg}$$

PTS: 2 REF: 060831ia STA: A.M.1 TOP: Using Rate

419 ANS: 4

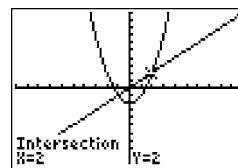

$$x^2 - 2 = x \quad \text{Since } y = x, \text{ the solutions are } (2, 2) \text{ and } (-1, -1).$$

$$x^2 - x - 2 = 0$$

$$(x - 2)(x + 1) = 0$$

$$x = 2 \text{ or } -1$$

PTS: 2 REF: 060810ia STA: A.A.11 TOP: Quadratic-Linear Systems

420 ANS: 1

$$x - 2y = 1$$

$$x + 4y = 7$$

$$-6y = -6$$

$$y = 1$$

PTS: 2 REF: 080920ia STA: A.A.10 TOP: Solving Linear Systems

421 ANS: 4

Surveying persons leaving a football game about a sports budget contains the most bias.

PTS: 2 REF: 080910ia STA: A.S.3 TOP: Analysis of Data

422 ANS:

 $\frac{3}{8}$. (H,H,H), (H,H,T), (H,T,H), (**H,T,T**), (T,H,H), (**T,H,T**), (**T,T,H**), (T,T,T)

PTS: 2

REF: 080933ia

STA: A.S.19

TOP: Sample Space

423 ANS:

 $\frac{1}{6}$, 16.67%, \$13.50. $\frac{18-15}{18} = \frac{1}{6}$. $18 \times 0.75 = 13.5$

PTS: 3

REF: 060835ia

STA: A.N.5

TOP: Percents

424 ANS: 2

$$x^2 - x - 20 = 3x - 15 \quad y = 3x - 15$$

$$x^2 - 4x - 6 = 0 \quad = 3(-1) - 15$$

$$(x - 5)(x + 1) = 0 \quad = -18$$

$$x = 5 \text{ or } -1$$

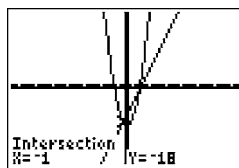

PTS: 2

REF: 010922ia

STA: A.A.11

TOP: Quadratic-Linear Systems

425 ANS: 2

$$P = 2l + 2w$$

$$P - 2l = 2w$$

$$\frac{P - 2l}{2} = w$$

PTS: 2

REF: 010911ia

STA: A.A.23

TOP: Transforming Formulas

426 ANS: 2

$$x^2 + 5x + 6 = -x + 1 \quad y = -x + 1$$

$$x^2 + 6x + 5 = 0 \quad = -(-5) + 1$$

$$(x + 5)(x + 1) = 0 \quad = 6$$

$$x = -5 \text{ or } -1$$

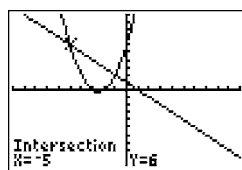

PTS: 2

REF: 080812ia

STA: A.A.11

TOP: Quadratic-Linear Systems

427 ANS: 2

$$\frac{6}{4a} - \frac{2}{3a} = \frac{18a - 8a}{12a^2} = \frac{10a}{12a^2} = \frac{5}{6a}$$

PTS: 2

REF: 060929ia

STA: A.A.17

TOP: Addition and Subtraction of Rationals

428 ANS: 1

$$13.95 + 0.49s \leq 50.00$$

$$0.49s \leq 36.05$$

$$s \leq 73.57$$

PTS: 2 REF: 080904ia STA: A.A.6 TOP: Modeling Inequalities

429 ANS: 3 PTS: 2 REF: 010917ia STA: A.A.29

TOP: Set Theory

430 ANS: 1 PTS: 2 REF: 080813ia STA: A.G.10

TOP: Identifying the Vertex of a Quadratic Given Graph

431 ANS: 4

$$\frac{344 \text{ m}}{\text{sec}} \times \frac{60 \text{ sec}}{1 \text{ min}} \times \frac{60 \text{ min}}{1 \text{ hr}} = 1,238,400 \frac{\text{m}}{\text{hr}}$$

PTS: 2 REF: 060911ia STA: A.M.2 TOP: Conversions

KEY: dimensional analysis

432 ANS:

$$m = 50¢, p = 15¢. \quad 3m + 2p = 1.80. \quad 9m + 6p = 5.40 \quad . \quad 4(.50) + 6p = 2.90$$

$$4m + 6p = 2.90 \quad 4m + 6p = 2.90 \quad 6p = .90$$

$$5m = 2.50 \quad p = \$0.15$$

$$m = \$0.50$$

PTS: 4 REF: 080837ia STA: A.A.7 TOP: Writing Linear Systems

433 ANS: 3

$$\sin A = \frac{10}{16} \quad B = 180 - (90 + 38.7) = 51.3. \quad \text{A } 90^\circ \text{ angle is not acute.}$$

$$A \approx 38.7$$

PTS: 2 REF: 080829ia STA: A.A.43 TOP: Using Trigonometry to Find an Angle

434 ANS: 3

$$F = \frac{9}{5}C + 32 = \frac{9}{5}(15) + 32 = 59$$

PTS: 2 REF: 010901ia STA: A.M.2 TOP: Conversions

KEY: formula

435 ANS: 1

To determine student interest, survey the widest range of students.

PTS: 2 REF: 060803ia STA: A.S.3 TOP: Analysis of Data

436 ANS: 2

The two values are shoe size and height.

PTS: 2 REF: fall0714ia STA: A.S.2 TOP: Analysis of Data

437 ANS: 1

$$8^2 + 15^2 = c^2$$

$$c^2 = 289$$

$$c = 17$$

PTS: 2 REF: 080906ia STA: A.A.45 TOP: Pythagorean Theorem

438 ANS: 2 PTS: 2 REF: 080930ia STA: A.S.17

TOP: Scatter Plots

439 ANS: 3 PTS: 2 REF: 060817ia STA: A.A.15

TOP: Undefined Rationals

440 ANS:

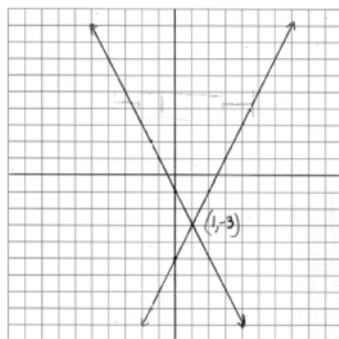

PTS: 4 REF: 080938ia STA: A.G.7 TOP: Solving Linear Systems

441 ANS: 4 PTS: 2 REF: fall0717ia STA: A.G.4

TOP: Families of Functions

442 ANS: 3

$$0.75 \text{ hours} = 45 \text{ minutes. } \frac{120}{1} = \frac{x}{45}$$

$$x = 5400$$

PTS: 2 REF: 080814ia STA: A.M.1 TOP: Using Rate

443 ANS: 1

$$\frac{4}{3}x + 5 < 17$$

$$\frac{4}{3}x < 12$$

$$4x < 36$$

$$x < 9$$

PTS: 2 REF: 060914ia STA: A.A.21 TOP: Interpreting Solutions

444 ANS: 4

$$\frac{\text{distance}}{\text{time}} = \frac{24}{6} = 4$$

PTS: 2 REF: 010902ia STA: A.M.1 TOP: Speed

445 ANS: 4

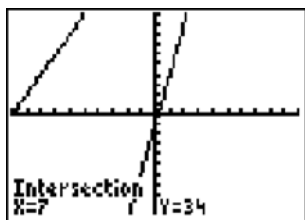

$$5p - 1 = 2p + 20$$

$$3p = 21$$

$$p = 7$$

PTS: 2

REF: 080801ia

STA: A.A.22

TOP: Solving Equations

446 ANS: 4

$$16^2 + b^2 = 34^2$$

$$b^2 = 900$$

$$b = 30$$

PTS: 2

REF: 080809ia

STA: A.A.45

TOP: Pythagorean Theorem

447 ANS:

56. If the circumference of circle O is 16π inches, the diameter, \overline{AD} , is 16 inches and the length of \overline{BC} is 12 inches $\frac{3}{4} \times 16$. The area of trapezoid $ABCD$ is $\frac{1}{2} \times 4(12 + 16) = 56$.

PTS: 3

REF: 060934ia

STA: A.G.1

TOP: Compositions of Polygons and Circles

KEY: area

448 ANS: 3

$$500(1 + 0.06)^3 \approx 596$$

PTS: 2

REF: 080929ia

STA: A.A.9

TOP: Exponential Functions

449 ANS: 1

$$\sin C = \frac{\text{opposite}}{\text{hypotenuse}} = \frac{13}{85}$$

PTS: 2

REF: fall0721ia

STA: A.A.42

TOP: Trigonometric Ratios

450 ANS: 2

$$\frac{x^2 - 2x - 15}{x^2 + 3x} = \frac{(x - 5)(x + 3)}{x(x + 3)} = \frac{x - 5}{x}$$

PTS: 2

REF: 060921ia

STA: A.A.16

TOP: Rational Expressions

KEY: $a > 0$

451 ANS: 1

$${}_4P_4 = 4 \times 3 \times 2 \times 1 = 24$$

PTS: 2

REF: 080816ia

STA: A.N.8

TOP: Permutations

452 ANS:

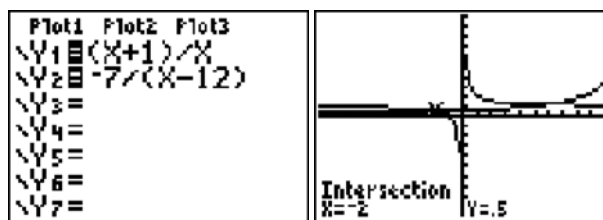

$$6, -2. \quad \frac{x+1}{x} = \frac{-7}{x-12}$$

$$(x+1)(x-12) = -7x$$

$$x^2 - 11x - 12 = -7x$$

$$x^2 - 4x - 12 = 0$$

$$(x-6)(x+2) = 0$$

$$x = 6 \text{ or } -2$$

PTS: 4 REF: fall0739ia STA: A.A.26 TOP: Solving Rationals

453 ANS: 2 PTS: 2 REF: 080815ia STA: A.G.1

TOP: Compositions of Polygons and Circles KEY: area

454 ANS: 2

$$\frac{6}{5x} - \frac{2}{3x} = \frac{18x - 10x}{15x^2} = \frac{8x}{15x^2} = \frac{8}{15x}$$

PTS: 2 REF: 010921ia STA: A.A.17 TOP: Addition and Subtraction of Rationals

455 ANS: 1

$$-2x + 5 > 17$$

$$-2x > 12$$

$$x < -6$$

PTS: 2 REF: fall0724ia STA: A.A.21 TOP: Interpreting Solutions

456 ANS: 1 PTS: 2 REF: 060903ia STA: A.A.12

TOP: Division of Powers

457 ANS: 4 PTS: 2 REF: 060829ia STA: A.G.5

TOP: Graphing Quadratic Functions

458 ANS: 1

$$\frac{(2x \times 6) + (3 \times x)}{3 \times 6} = 5$$

$$\frac{12x + 3x}{18} = 5$$

$$15x = 90$$

$$x = 6$$

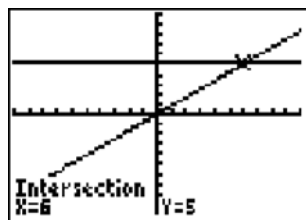

PTS: 2 REF: 060907ia STA: A.A.25

TOP: Solving Equations with Fractional Expressions

459 ANS: 1 PTS: 2 REF: 060804ia STA: A.A.19

TOP: Factoring the Difference of Perfect Squares

460 ANS: 1

$m = \frac{3-0}{0-2} = -\frac{3}{2}$. Using the given y -intercept $(0,3)$ to write the equation of the line $y = -\frac{3}{2}x + 3$.

PTS: 2 REF: fall0713ia STA: A.A.35 TOP: Writing Linear Equations

461 ANS: 1 PTS: 2 REF: 080824ia STA: A.A.43

TOP: Using Trigonometry to Find an Angle

462 ANS: 4 PTS: 2 REF: 080903ia STA: A.A.12

TOP: Multiplication of Powers

463 ANS: 4



PTS: 2 REF: 080822ia STA: A.S.8 TOP: Scatter Plots

464 ANS: 2 PTS: 2 REF: 060908ia STA: A.S.21

TOP: Empirical Probability

465 ANS: 2 PTS: 2 REF: 010925ia STA: A.A.15

TOP: Undefined Rationals

466 ANS: 2

$$\frac{9x^4 - 27x^6}{3x^3} = \frac{9x^4(1 - 3x^2)}{3x^3} = 3x(1 - 3x^2)$$

PTS: 2 REF: fall0718ia STA: A.A.16 TOP: Rational Expressions

KEY: $a > 0$

467 ANS:

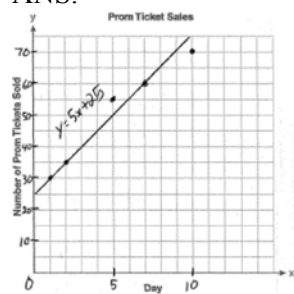

PTS: 3

REF: 060936ia

STA: A.S.8

TOP: Scatter Plots

Integrated Algebra Regents at Random Answer Section

468 ANS: 3 PTS: 2 REF: 061218ia STA: A.S.20
TOP: Geometric Probability

469 ANS:
 $5,583.86. A = P(1 + R)^t = 5000(1 + 0.0375)^3 \approx 5583.86$

PTS: 3 REF: 060935ia STA: A.A.9 TOP: Exponential Functions
470 ANS: 2 PTS: 2 REF: 081218ia STA: A.G.5
TOP: Graphing Quadratic Functions

471 ANS: 4
 $3x^3 - 33x^2 + 90x = 3x(x^2 - 11x + 30) = 3x(x - 5)(x - 6)$

PTS: 2 REF: 061227ia STA: A.A.20 TOP: Factoring Polynomials
472 ANS: 3

$$\frac{2}{x+1} = \frac{x+1}{2}$$

$$x^2 + 2x + 1 = 4$$

$$x^2 + 2x - 3 = 0$$

$$(x + 3)(x - 1) = 3$$

$$x = -3, 1$$

PTS: 2 REF: 081226ia STA: A.A.26 TOP: Solving Rationals
473 ANS: 2

$$W + L = 72$$

$$W - L = 12$$

$$2W = 84$$

$$W = 42$$

PTS: 2 REF: 081227ia STA: A.A.7 TOP: Writing Linear Systems
474 ANS: 2 PTS: 2 REF: 081311ia STA: A.A.12
TOP: Division of Powers

475 ANS:

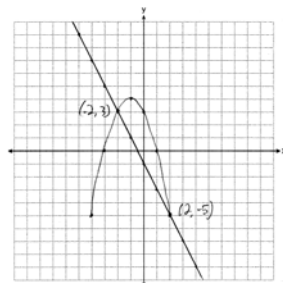

PTS: 4 REF: 081337ia STA: A.G.9 TOP: Quadratic-Linear Systems

- 476 ANS: 3 PTS: 2 REF: 081208ia STA: A.S.17
TOP: Scatter Plots
- 477 ANS: 1 PTS: 2 REF: 011207ia STA: A.G.9
TOP: Quadratic-Linear Systems
- 478 ANS:
 $(-3, -5), (3, 7)$. $x^2 + 2x - 8 = 2x + 1$. $y = 2(3) + 1 = 7$
 $x^2 - 9 = 0$ $y = 2(-3) + 1 = -5$
 $x = \pm 3$
- PTS: 3 REF: 081236ia STA: A.A.11 TOP: Quadratic-Linear Systems
- 479 ANS: 3 PTS: 2 REF: 011309ia STA: A.G.3
TOP: Defining Functions KEY: graphs
- 480 ANS: 4
 $\frac{95000}{125000} = .76$
- PTS: 2 REF: 061207ia STA: A.S.11 TOP: Quartiles and Percentiles
- 481 ANS: 2
 $s^3 = 8$. $6 \times (2 \times 2) = 24$
 $s = 2$
- PTS: 2 REF: 081325ia STA: A.G.2 TOP: Surface Area
- 482 ANS: 3 PTS: 2 REF: 011310ia STA: A.A.9
TOP: Exponential Functions
- 483 ANS:
White. There are 31 white blocks, 30 red blocks and 29 blue blocks.
- PTS: 2 REF: 061232ia STA: A.S.22 TOP: Theoretical Probability
- 484 ANS:
 $5 \times 3 \times 5 \times 3 = 225$. $1 \times 3 \times 5 \times 3 = 45$. $1 \times 2 \times 5 \times 3 = 30$
- PTS: 4 REF: 061334ia STA: A.N.7 TOP: Multiplication Counting Principle
- 485 ANS:
 $\tan 48 = \frac{9}{x}$. $\sin 48 = \frac{9}{y}$
 $x \approx 8$ $y \approx 12$
- PTS: 4 REF: 011338ia STA: A.A.44 TOP: Using Trigonometry to Find a Side
- 486 ANS: 3 PTS: 2 REF: 061324ia STA: A.A.31
TOP: Set Theory
- 487 ANS: 1
Using $m = -\frac{A}{B}$, the slope of $2x - 3y = 9$ is $\frac{2}{3}$.
- PTS: 2 REF: 011322ia STA: A.A.38 TOP: Parallel and Perpendicular Lines

488 ANS: 3

$$N = 5 + J \quad N(N - 5) = 84$$

$$J = N - 5 \quad N^2 - 5N - 84 = 0$$

$$NJ = 84 \quad (N - 12)(N + 7) = 0$$

$$N = 12$$

PTS: 2

REF: 081304ia

STA: A.A.8

TOP: Writing Quadratics

489 ANS: 3

PTS: 2

REF: 081317ia

STA: A.A.21

TOP: Interpreting Solutions

490 ANS: 4

PTS: 2

REF: 081322ia

STA: A.G.10

TOP: Identifying the Vertex of a Quadratic Given Graph

491 ANS:

$$\frac{5.4 \text{ miles}}{\text{hour}} \times \frac{5280 \text{ feet}}{\text{mile}} \times \frac{1 \text{ hour}}{60 \text{ min}} = \frac{475.2 \text{ ft}}{\text{min}}$$

PTS: 2

REF: 081331ia

STA: A.M.2

TOP: Conversions

KEY: dimensional analysis

492 ANS: 4

$$2(2) - (-7) = 11$$

PTS: 2

REF: 081217ia

STA: A.A.39

TOP: Identifying Points on a Line

493 ANS: 1

$$\frac{20 - 6}{(20 - 6) + 15 + 7 + 8} = \frac{14}{44}$$

PTS: 2

REF: 061302ia

STA: A.S.18

TOP: Conditional Probability

494 ANS:

$26 \times 25 \times 24 \times 23 = 358,800$. $10^6 = 1,000,000$. Use the numeric password since there are over 500,000 employees

PTS: 4

REF: 061239ia

STA: A.N.8

TOP: Permutations

495 ANS:

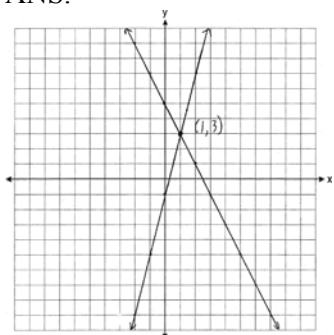

PTS: 3

REF: 011235ia

STA: A.G.7

TOP: Solving Linear Systems

- 496 ANS: 3
Due to lack of specificity in the wording, this 13th question was removed from the June, 2013 Regents Exam.
- PTS: 2 REF: 061313ia STA: A.S.2 TOP: Analysis of Data
- 497 ANS: 3
 ${}_{18}P_3 = 4896$
- PTS: 2 REF: 061328ia STA: A.N.8 TOP: Permutations
- 498 ANS: 2
People at a gym or football game and members of a soccer team are more biased towards sports.
- PTS: 2 REF: 061202ia STA: A.S.3 TOP: Analysis of Data
- 499 ANS:
3, 0, 20. $15 - 12 = 3$. $12 - 12 = 0$
- PTS: 3 REF: 081234ia STA: A.S.9
TOP: Frequency Histograms, Bar Graphs and Tables
- 500 ANS: 3
 $5x < 55$
 $x < 11$
- PTS: 2 REF: 061211ia STA: A.A.6 TOP: Modeling Inequalities
- 501 ANS: 2 PTS: 2 REF: 011201ia STA: A.A.19
TOP: Factoring the Difference of Perfect Squares
- 502 ANS: 1
 $\frac{\text{distance}}{\text{time}} = \frac{350.7}{4.2} = 83.5$
- PTS: 2 REF: 061201ia STA: A.M.1 TOP: Speed
- 503 ANS: 4
The transformation is a reflection in the x -axis.
- PTS: 2 REF: 011206ia STA: A.G.5 TOP: Graphing Absolute Value Functions
- 504 ANS: 2 PTS: 2 REF: 011316ia STA: A.A.14
TOP: Division of Polynomials
- 505 ANS: 2
 $\left| \frac{(2.6 \times 6.9) - (2.5 \times 6.8)}{(2.6 \times 6.9)} \right| \approx 0.052$
- PTS: 2 REF: 011209ia STA: A.M.3 TOP: Error
KEY: area
- 506 ANS: 2 PTS: 2 REF: 011330ia STA: A.G.5
TOP: Graphing Quadratic Functions

507 ANS:

2. Subtracting the equations: $3y = 6$

$$y = 2$$

PTS: 2

REF: 061231ia

STA: A.A.10

TOP: Solving Linear Systems

508 ANS: 4

PTS: 2

REF: 061203ia

STA: A.A.14

TOP: Division of Polynomials

509 ANS:

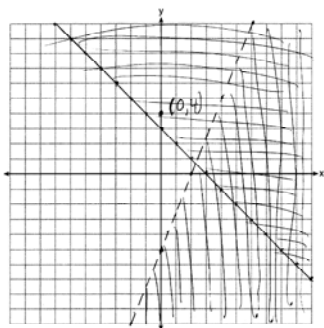

PTS: 4

REF: 081239ia

STA: A.G.7

TOP: Systems of Linear Inequalities

510 ANS: 4

$$5 - 2x = -4x - 7$$

$$2x = -12$$

$$x = -6$$

PTS: 2

REF: 011305ia

STA: A.A.22

TOP: Solving Equations

511 ANS: 3

 $(2, T), (4, T), (6, T)$

PTS: 2

REF: 081324ia

STA: A.S.19

TOP: Sample Space

512 ANS:

$$\frac{6}{25} \cdot \frac{25 - (11 + 5 + 3)}{25}$$

PTS: 2

REF: 011232ia

STA: A.S.21

TOP: Experimental Probability

513 ANS:

$$78. \cos x = \frac{6}{28}$$

$$x \approx 78$$

PTS: 3

REF: 061235ia

STA: A.A.43

TOP: Using Trigonometry to Find an Angle

514 ANS: 4

PTS: 2

REF: 061222ia

STA: A.A.40

TOP: Systems of Linear Inequalities

515 ANS: 4

$$x^2 - 14x + 48 = 0$$

$$(x - 6)(x - 8) = 0$$

$$x = 6, 8$$

PTS: 2 REF: 011320ia STA: A.A.28 TOP: Roots of Quadratics

516 ANS: 3

$$6! + \frac{5!(3!)}{4!} - 10 = 720 + 5(6) - 10 = 740$$

PTS: 2 REF: 061309ia STA: A.N.6 TOP: Evaluating Expressions

517 ANS: 4

$$m = \frac{-A}{B} = \frac{-(-3)}{2} = \frac{3}{2}$$

PTS: 2 REF: 061212ia STA: A.A.37 TOP: Slope

518 ANS: 1 PTS: 2 REF: 081301ia STA: A.S.12

TOP: Scatter Plots

519 ANS:

$$6\sqrt{3} \frac{3\sqrt{75} + \sqrt{27}}{3} = \frac{3\sqrt{25}\sqrt{3} + \sqrt{9}\sqrt{3}}{3} = \frac{15\sqrt{3} + 3\sqrt{3}}{3} = \frac{18\sqrt{3}}{3} = 6\sqrt{3}$$

PTS: 3 REF: 061236ia STA: A.N.3 TOP: Operations with Radicals

520 ANS: 4 PTS: 2 REF: 011308ia STA: A.S.18

TOP: Conditional Probability

521 ANS: 3 PTS: 2 REF: 081207ia STA: A.A.19

TOP: Factoring the Difference of Perfect Squares

522 ANS: 1

$$\frac{1}{7} + \frac{2x}{3} = \frac{15x - 3}{21}$$

$$\frac{14x + 3}{21} = \frac{15x - 3}{21}$$

$$14x + 3 = 15x - 3$$

$$x = 6$$

PTS: 2 REF: 011328ia STA: A.A.25

TOP: Solving Equations with Fractional Expressions

523 ANS:

$$4. \quad 3(x+1) - 5x = 12 - (6x - 7)$$

$$3x + 3 - 5x = 12 - 6x + 7$$

$$-2x + 3 = -6x + 19$$

$$4x = 16$$

$$x = 4$$

PTS: 4

REF: 061238ia

STA: A.A.22

TOP: Solving Equations

524 ANS: 4

$$3 + 2 - 1 = 4$$

PTS: 2

REF: 081320ia

STA: A.A.6

TOP: Venn Diagrams

525 ANS:

$$7, 9, 11. \quad x + (x+2) + (x+4) = 5(x+2) - 18$$

$$3x + 6 = 5x - 8$$

$$14 = 2x$$

$$7 = x$$

PTS: 4

REF: 011237ia

STA: A.A.6

TOP: Modeling Equations

526 ANS:

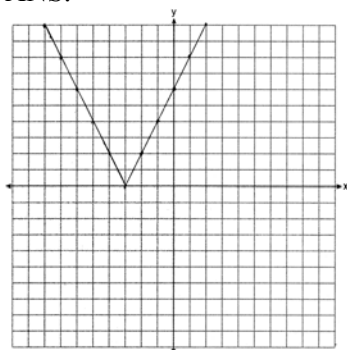

PTS: 2

REF: 011333ia

STA: A.G.4

TOP: Graphing Absolute Value Functions

527 ANS: 4

$$P(\text{odd}) = \frac{7+14+20}{75} = \frac{41}{75}. \quad P(\text{even}) = \frac{22+6+6}{75} = \frac{34}{75}. \quad P(3 \text{ or less}) = \frac{14+22+7}{75} = \frac{43}{75}.$$

$$P(2 \text{ or } 4) = \frac{22+6}{75} = \frac{28}{75}$$

PTS: 2

REF: 011325ia

STA: A.S.22

TOP: Theoretical Probability

528 ANS: 2

PTS: 2

REF: 081314ia

STA: A.G.6

TOP: Linear Inequalities

529 ANS: 2

PTS: 2

REF: 081215ia

STA: A.A.1

TOP: Expressions

530 ANS:

$$\frac{2}{3x} + \frac{12}{3x} = \frac{7}{x+1}$$

$$\frac{14}{3x} = \frac{7}{x+1}$$

$$21x = 14x + 14$$

$$7x = 14$$

$$x = 2$$

PTS: 4 REF: 061337ia STA: A.A.26 TOP: Solving Rationals

531 ANS: 1

$$\frac{(x+5)(x+3)}{x+5} = x+3$$

PTS: 2 REF: 0613071a STA: A.A.16 TOP: Rational Expressions

KEY: $a > 0$

532 ANS: 2

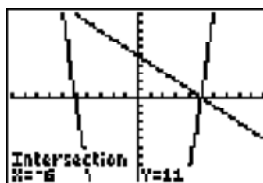

$$y = -x + 5. \quad -x + 5 = x^2 - 25 \quad . \quad y = -(-6) + 5 = 11.$$

$$0 = x^2 + x - 30 \quad y = -5 + 5 = 0$$

$$0 = (x+6)(x-5)$$

$$x = -6, 5$$

PTS: 2 REF: 061213ia STA: A.A.11 TOP: Quadratic-Linear Systems

533 ANS: 1

$$k = am + 3mx$$

$$k = m(a + 3x)$$

$$\frac{k}{a + 3x} = m$$

PTS: 2 REF: 061215ia STA: A.A.23 TOP: Transforming Formulas

534 ANS: 1

$$4(5 + 5) + 10\pi = 40 + 10\pi$$

PTS: 2 REF: 081326ia STA: A.G.1 TOP: Compositions of Polygons and Circles

KEY: perimeter

535 ANS: 1

$$\left| \frac{4(-6) + 18}{4!} \right| = \left| \frac{-6}{24} \right| = \frac{1}{4}$$

PTS: 2 REF: 081220ia STA: A.N.6 TOP: Evaluating Expressions

536 ANS: 2 PTS: 2 REF: 081205ia STA: A.A.13
TOP: Addition and Subtraction of Polynomials KEY: addition

537 ANS: 1

$$\frac{3}{4} \times 5 = \frac{15}{4} \text{ teaspoons} \times \frac{1 \text{ tablespoon}}{3 \text{ teaspoons}} = \frac{5}{4} = 1 \frac{1}{4} \text{ tablespoon}$$

PTS: 2 REF: 061228ia STA: A.M.2 TOP: Conversions
KEY: dimensional analysis

538 ANS: 1

$$x = \frac{-b}{2a} = \frac{-(-3)}{2(2)} = \frac{3}{4}$$

PTS: 2 REF: 011219ia STA: A.A.41
TOP: Identifying the Vertex of a Quadratic Given Equation

539 ANS: 1 PTS: 2 REF: 011306ia STA: A.A.19
TOP: Factoring the Difference of Perfect Squares

540 ANS: 3 PTS: 2 REF: 011304ia STA: A.G.7
TOP: Solving Linear Systems

541 ANS: 2 PTS: 2 REF: 061327ia STA: A.A.36
TOP: Parallel and Perpendicular Lines

542 ANS:

$$\left| \frac{(24.2 \times 14.1) - (24 \times 14)}{(24.2 \times 14.1)} \right| = \frac{5.22}{341.22} \approx 0.015$$

PTS: 3 REF: 011335ia STA: A.M.3 TOP: Error
KEY: area

543 ANS:

$$3n + 4p = 8.50 \quad 3(2.50) + 4p = 8.50$$

$$5n + 8p = 14.50 \quad 4p = 1$$

$$6n + 8p = 17 \quad p = 0.25$$

$$n = 2.50$$

PTS: 3 REF: 011335ia STA: A.A.7 TOP: Writing Linear Systems
544 ANS: 3 PTS: 2 REF: 081201ia STA: A.G.7
TOP: Solving Linear Systems

545 ANS: 4 PTS: 2 REF: 061226ia STA: A.A.13
TOP: Addition and Subtraction of Polynomials KEY: subtraction

546 ANS:

$$\text{Carol's, by 14.9. } V_M = 5 \times 3.5 \times 7 = 122.5. \quad V_C = \pi \times 2.5^2 \times 7 \approx 137.4. \quad 137.4 - 122.5 = 14.9$$

PTS: 4 REF: 061237ia STA: A.G.2 TOP: Volume
547 ANS: 3 PTS: 2 REF: 011317ia STA: A.M.2
TOP: Conversions KEY: dimensional analysis

- 548 ANS: 3
The other situations are qualitative.
- PTS: 2 REF: 081213ia STA: A.S.1 TOP: Analysis of Data
- 549 ANS: 3
 $\frac{10^3}{5^3} = \frac{1000}{125} = 8$
- PTS: 2 REF: 011312ia STA: A.G.2 TOP: Volume
- 550 ANS: 3 PTS: 2 REF: 061206ia STA: A.S.2
TOP: Analysis of Data
- 551 ANS: 3
 $\frac{120}{60} = \frac{m}{150}$
 $m = 300$
- PTS: 2 REF: 081202ia STA: A.M.1 TOP: Using Rate
- 552 ANS:
 $\frac{8100 - 7678.5}{7678.5} \approx 0.055$
- PTS: 2 REF: 061233ia STA: A.M.3 TOP: Error
KEY: area
- 553 ANS: 1
 $m = -3$
- PTS: 2 REF: 081307ia STA: A.A.38 TOP: Parallel and Perpendicular Lines
- 554 ANS: 1 PTS: 2 REF: 061209ia STA: A.G.3
TOP: Defining Functions KEY: graphs
- 555 ANS: 1 PTS: 2 REF: 061322ia STA: A.A.13
TOP: Addition and Subtraction of Polynomials KEY: subtraction
- 556 ANS: 1 PTS: 2 REF: 061315ia STA: A.A.15
TOP: Undefined Rationals
- 557 ANS: 1
 $4 + 6 + 10 + \frac{6\pi}{2} = 20 + 3\pi$
- PTS: 2 REF: 081228ia STA: A.G.1 TOP: Compositions of Polygons and Circles
KEY: perimeter
- 558 ANS:
 $4\sqrt{75} = 4\sqrt{25}\sqrt{3} = 20\sqrt{3}$
- PTS: 2 REF: 011331ia STA: A.N.2 TOP: Simplifying Radicals

559 ANS: 4

$$\frac{(4x^3)^2}{2x} = \frac{16x^6}{2x} = 8x^5$$

PTS: 2 REF: 011216ia STA: A.A.12 TOP: Powers of Powers

560 ANS: 4 PTS: 2 REF: 081312ia STA: A.S.6

TOP: Box-and-Whisker Plots

561 ANS:

$$\frac{12}{20} \times \frac{8}{19} + \frac{8}{20} \times \frac{12}{19} = \frac{192}{380}. \quad 1 - P(BB) = 1 - \left(\frac{8}{20} \times \frac{7}{19} \right) = \frac{380}{380} - \frac{56}{380} = \frac{324}{380}$$

PTS: 4 REF: 081339ia STA: A.S.23 TOP: Theoretical Probability

KEY: dependent events

562 ANS: 3

$$\sqrt{13^2 - 7^2} = \sqrt{120}$$

PTS: 2 REF: 081323ia STA: A.A.45 TOP: Pythagorean Theorem

563 ANS: 3 PTS: 2 REF: 011315ia STA: A.G.1

TOP: Compositions of Polygons and Circles KEY: area

564 ANS: 4 PTS: 2 REF: 081229ia STA: A.S.23

TOP: Theoretical Probability KEY: independent events

565 ANS:

$$\tan x = \frac{350}{1000}$$

$$x \approx 19$$

PTS: 3 REF: 061335ia STA: A.A.43 TOP: Using Trigonometry to Find an Angle

566 ANS:

$$\text{Area of rectangle minus area of semicircle: } (5 + 6 + 5) \times 5 - \frac{\pi \times 3^2}{2} \approx 65.86$$

PTS: 4 REF: 061339ia STA: A.G.1 TOP: Compositions of Polygons and Circles

KEY: area

567 ANS: 2 PTS: 2 REF: 081327ia STA: A.S.16

TOP: Central Tendency

568 ANS: 1 PTS: 2 REF: 081209ia STA: A.N.1

TOP: Properties of Reals

569 ANS:

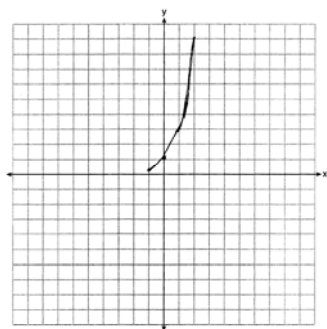

PTS: 2 REF: 081233ia STA: A.G.4 TOP: Graphing Exponential Functions

570 ANS: 1 PTS: 2 REF: 011303ia STA: A.A.1
TOP: Expressions571 ANS: 3
The other situations are quantitative.

PTS: 2 REF: 081313ia STA: A.S.1 TOP: Analysis of Data

572 ANS: 3
$$x = \frac{-b}{2a} = \frac{-24}{2(-2)} = 6. \quad y = -2(6)^2 + 24(6) - 100 = -28$$
PTS: 2 REF: 061214ia STA: A.A.41
TOP: Identifying the Vertex of a Quadratic Given Equation573 ANS:
$$\begin{aligned} L - S &= 28 & 2S - 8 &= S + 28 \\ L &= 2S - 8 & S &= 36 \\ L &= S + 28 & L &= 36 + 28 = 64 \end{aligned}$$

PTS: 3 REF: 081335ia STA: A.A.7 TOP: Writing Linear Systems

574 ANS: 3 PTS: 2 REF: 081230ia STA: A.A.23
TOP: Transforming Formulas575 ANS: 2 PTS: 2 REF: 061229ia STA: A.A.9
TOP: Exponential Functions576 ANS: 3 PTS: 2 REF: 061225ia STA: A.A.5
TOP: Modeling Equations577 ANS: 1
The other situations are quantitative.

PTS: 2 REF: 061308ia STA: A.S.1 TOP: Analysis of Data

578 ANS: 2

$$\frac{x+2}{2} = \frac{4}{x}$$

$$x^2 + 2x = 8$$

$$x^2 + 2x - 8 = 0$$

$$(x+4)(x-2) = 0$$

$$x = -4, 2$$

PTS: 2

REF: 061317ia

STA: A.A.26

TOP: Solving Rationals

579 ANS:

$$\frac{x-1}{x+2} \cdot \frac{x^2-1}{x^2+3x+2} = \frac{(x+1)(x-1)}{(x+2)(x+1)}$$

PTS: 2

REF: 011233ia

STA: A.A.16

TOP: Rational Expressions

KEY: $a > 0$

580 ANS: 2

$$m = \frac{-7-1}{4-9} = \frac{-8}{-5} = \frac{8}{5}$$

PTS: 2

REF: 081310ia

STA: A.A.33

TOP: Slope

581 ANS: 1

PTS: 2

REF: 011213ia

STA: A.A.13

TOP: Addition and Subtraction of Polynomials

KEY: addition

582 ANS: 3

PTS: 2

REF: 011220ia

STA: A.S.6

TOP: Box-and-Whisker Plots

583 ANS: 4

$$8900 \text{ ft} \times \frac{1 \text{ mi}}{5280 \text{ ft}} \approx 1.7 \text{ mi}$$

PTS: 2

REF: 081210ia

STA: A.M.2

TOP: Conversions

KEY: dimensional analysis

584 ANS: 1

PTS: 2

REF: 061301ia

STA: A.A.1

TOP: Expressions

585 ANS: 3

PTS: 2

REF: 011204ia

STA: A.G.3

TOP: Defining Functions

KEY: graphs

586 ANS:

$$54, 23. \cos A = \frac{17}{29}. \sqrt{29^2 - 17^2} \approx 23$$

$$x \approx 54$$

PTS: 4

REF: 081238ia

STA: A.A.43

TOP: Using Trigonometry to Find an Angle

587 ANS: 2

PTS: 2

REF: 081223ia

STA: A.A.32

TOP: Slope

588 ANS:

$$5 - 2\sqrt{3} + \sqrt{9}\sqrt{3} + 2(3) = 5 - 2\sqrt{3} + 3\sqrt{3} + 6 = 11 + \sqrt{3}$$

PTS: 3 REF: 061336ia STA: A.N.3 TOP: Operations with Radicals

589 ANS:

$$800 - (895)(0.75)(1.08) = 75.05$$

PTS: 3 REF: 081334ia STA: A.N.5 TOP: Percents

590 ANS: 4 PTS: 2 REF: 011225ia STA: A.A.31

TOP: Set Theory

591 ANS: 3 PTS: 2 REF: 011324ia STA: A.A.36

TOP: Parallel and Perpendicular Lines

592 ANS: 4

If $m\angle C = 90$, then \overline{AB} is the hypotenuse, and the triangle is a 3-4-5 triangle.

PTS: 2 REF: 061224ia STA: A.A.42 TOP: Trigonometric Ratios

593 ANS: 2

$$-1 \leq 3(2) + 1. \quad 2 - (-1) > 1$$

$$-1 \leq 7 \qquad 3 > 1$$

PTS: 2 REF: 011323ia STA: A.A.40 TOP: Systems of Linear Inequalities

594 ANS:

$$\frac{(10.75)(12.5) - (10.5)(12.25)}{(10.75)(12.5)} \approx 0.043$$

PTS: 3 REF: 081336ia STA: A.M.3 TOP: Error

KEY: area

595 ANS: 3 PTS: 2 REF: 061318ia STA: A.G.4

TOP: Families of Functions

596 ANS: 4

$$x^2 - 2x - 15 = 0$$

$$(x + 3)(x - 5) = 0$$

$$x = -3, 5$$

PTS: 2 REF: 081316ia STA: A.A.15 TOP: Undefined Rationals

597 ANS: 1 PTS: 2 REF: 081302ia STA: A.A.13

TOP: Addition and Subtraction of Polynomials

KEY: addition

598 ANS: 1

If the area of the square is 36, a side is 6, the diameter of the circle is 6, and its radius is 3. $A = \pi r^2 = 3^2 \pi = 9\pi$

PTS: 2 REF: 011217ia STA: A.G.1 TOP: Compositions of Polygons and Circles

KEY: area

599 ANS: 4 PTS: 2 REF: 061321ia STA: A.A.5

TOP: Modeling Inequalities

600 ANS:
 (W,H,A), (W,H,S), (W,T,A), (W,T,S), (W,B,A), (W,B,S), (R,H,A), (R,H,S), (R,T,A), (R,T,S), (R,B,A), (R,B,S).
 8, 3

PTS: 4 REF: 011238ia STA: A.S.19 TOP: Sample Space

601 ANS: 2

$$|-3 - 4| - (-3)^2 = 7 - 9 = -2$$

PTS: 2 REF: 011321ia STA: A.N.6 TOP: Evaluating Expressions

602 ANS: 3

$$x = \frac{-b}{2a} = \frac{-8}{2(1)} = -4. y = (-4)^2 + 8(-4) + 10 = -6. (-4, -6)$$

PTS: 2 REF: 011314ia STA: A.A.41
 TOP: Identifying the Vertex of a Quadratic Given Equation

603 ANS: 3 PTS: 2 REF: 061217ia STA: A.A.29

TOP: Set Theory

604 ANS: 4 PTS: 2 REF: 081214ia STA: A.G.10

TOP: Identifying the Vertex of a Quadratic Given Graph

605 ANS: 1 PTS: 2 REF: 061220ia STA: A.A.17

TOP: Addition and Subtraction of Rationals

606 ANS: 1

$$\sqrt{1700^2 - 1300^2} \approx 1095$$

PTS: 2 REF: 011221ia STA: A.A.45 TOP: Pythagorean Theorem

607 ANS: 3

$$\frac{3^6}{3^1} = 3^5$$

PTS: 2 REF: 061219ia STA: A.A.12 TOP: Division of Powers

608 ANS:

The turtle won by .5 minutes. Turtle: $\frac{d}{s} = \frac{100}{20} = 5$. Rabbit: $\frac{d}{s} = \frac{100}{40} = 2.5 + 3 = 5.5$

PTS: 3 REF: 011236ia STA: A.M.1 TOP: Speed

609 ANS:

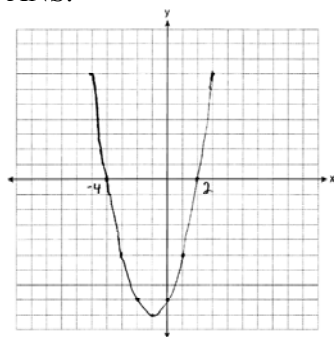

PTS: 3 REF: 061234ia STA: A.G.8 TOP: Solving Quadratics by Graphing

610 ANS: 2

mean = 7, median = 6 and mode = 6

PTS: 2 REF: 011329ia STA: A.S.4 TOP: Central Tendency

611 ANS:

$$2\sqrt{108} = 2\sqrt{36} \cdot \sqrt{3} = 12\sqrt{3}$$

PTS: 2 REF: 081332ia STA: A.N.2 TOP: Simplifying Radicals

612 ANS: 1

$$x^2 + 5x - 6 = 0$$

$$(x + 6)(x - 1) = 0$$

$$x = -6, 1$$

PTS: 2 REF: 011214ia STA: A.A.15 TOP: Undefined Rationals

613 ANS: 2

$$\frac{2y}{y+5} + \frac{10}{y+5} = \frac{2y+10}{y+5} = \frac{2(y+5)}{y+5} = 2$$

PTS: 2 REF: 011230ia STA: A.A.17 TOP: Addition and Subtraction of Rationals

614 ANS:

$$147.75 \cdot 2 \times 5.5 \times 3 + 2 \times 6.75 \times 3 + 2 \times 5.5 \times 6.75 = 147.75$$

PTS: 2 REF: 011231ia STA: A.G.2 TOP: Surface Area

615 ANS: 2

PTS: 2

REF: 011212ia

STA: A.S.23

TOP: Theoretical Probability

KEY: independent events

616 ANS: 3

$$\tan PLM = \frac{\text{opposite}}{\text{adjacent}} = \frac{4}{3}$$

PTS: 2 REF: 011226ia STA: A.A.42 TOP: Trigonometric Ratios

617 ANS: 4

PTS: 2

REF: 011222ia

STA: A.A.29

TOP: Set Theory

618 ANS:

$$6.56 \times 10^{-2}$$

PTS: 2 REF: 081231ia STA: A.N.4 TOP: Operations with Scientific Notation

619 ANS: 2

$$\frac{x^2 - 3x - 10}{x^2 - 25} = \frac{(x-5)(x+2)}{(x+5)(x-5)} = \frac{x+2}{x+5}$$

PTS: 2 REF: 061216ia STA: A.A.16 TOP: Rational Expressions

KEY: $a > 0$

620 ANS: 3 PTS: 2 REF: 011224ia STA: A.N.1

TOP: Properties of Reals

621 ANS: 3

$$2\sqrt{45} = 2\sqrt{9}\sqrt{5} = 6\sqrt{5}$$

PTS: 2 REF: 011203ia STA: A.N.2 TOP: Simplifying Radicals

622 ANS:

$$2(x-4) \geq \frac{1}{2}(5-3x)$$

$$4(x-4) \geq 5-3x$$

$$4x-16 \geq 5-3x$$

$$7x \geq 21$$

$$x \geq 3$$

PTS: 3 REF: 011234ia STA: A.A.24 TOP: Solving Inequalities

623 ANS: 2

The other sets of data are qualitative.

PTS: 2 REF: 011211ia STA: A.S.1 TOP: Analysis of Data

624 ANS:

$$t = \frac{d}{s} = \frac{136,000,000}{31,000} \approx 4387.1 \text{ hours. } \frac{4387.1}{24} \approx 183$$

PTS: 2 REF: 061333ia STA: A.M.1 TOP: Speed

625 ANS: 3 PTS: 2 REF: 061303ia STA: A.S.17

TOP: Scatter Plots

626 ANS: 4

$$375 + 155w \geq 900$$

$$155w \geq 525$$

$$w \geq 3.4$$

PTS: 2 REF: 081206ia STA: A.A.6 TOP: Modeling Inequalities

627 ANS: 1

$$s = \frac{2x+t}{r}$$

$$rs = 2x + t$$

$$rs - t = 2x$$

$$\frac{rs-t}{2} = x$$

PTS: 2

REF: 011228ia

STA: A.A.23

TOP: Transforming Formulas

628 ANS:

$$-5(x-7) < 15$$

$$x-7 > -3$$

$$x > 4$$

PTS: 2

REF: 061331ia

STA: A.A.24

TOP: Solving Inequalities

629 ANS: 3

$$y = mx + b \quad y = \frac{3}{4}x - \frac{1}{2}$$

$$1 = \left(\frac{3}{4}\right)(2) + b \quad 4y = 3x - 2$$

$$1 = \frac{3}{2} + b$$

$$b = -\frac{1}{2}$$

PTS: 2

REF: 081219ia

STA: A.A.34

TOP: Writing Linear Equations

630 ANS: 2

PTS: 2

REF: 061312ia

STA: A.A.12

TOP: Powers of Powers

631 ANS: 4

$$3y + 2x = 8$$

$$3(-2) + 2(7) = 8$$

$$-6 + 14 = 8$$

PTS: 2

REF: 011218ia

STA: A.A.39

TOP: Identifying Points on a Line

632 ANS: 3

$$2(5) + k = 9$$

$$10 + k = 9$$

$$k = -1$$

PTS: 2

REF: 061304ia

STA: A.A.39

TOP: Identifying Points on a Line

633 ANS: 3

PTS: 2

REF: 061230ia

STA: A.S.9

TOP: Frequency Histograms, Bar Graphs and Tables

634 ANS: 3

PTS: 2

REF: 061323ia

STA: A.A.1

TOP: Expressions

635 ANS: 1 PTS: 2 REF: 011210ia STA: A.G.6
TOP: Linear Inequalities

636 ANS:

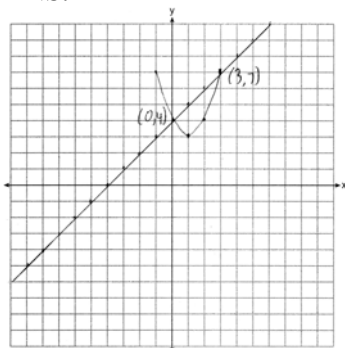

PTS: 4 REF: 011339ia STA: A.G.9 TOP: Quadratic-Linear Systems
637 ANS: 2

$$13^2 + 13^2 = x^2$$

$$338 = x^2$$

$$\sqrt{338} = x$$

$$18 \approx x$$

PTS: 2 REF: 061223ia STA: A.A.45 TOP: Pythagorean Theorem
638 ANS: 3

$$0.06y + 200 = 0.03y + 350$$

$$0.03y = 150$$

$$y = 5,000$$

PTS: 2 REF: 081203ia STA: A.A.25 TOP: Solving Equations with Decimals
639 ANS: 4 PTS: 2 REF: 061221ia STA: A.G.4
TOP: Identifying the Equation of a Graph

640 ANS: 1 PTS: 2 REF: 081319ia STA: A.N.1
TOP: Identifying Properties

641 ANS:

$$\frac{x+2}{2} \times \frac{4(x+5)}{(x+4)(x+2)} = \frac{2(x+5)}{x+4}$$

PTS: 2 REF: 081232ia STA: A.A.18 TOP: Multiplication and Division of Rationals
KEY: multiplication

642 ANS: 1 PTS: 2 REF: 081204ia STA: A.S.12
TOP: Scatter Plots

643 ANS: 2 PTS: 2 REF: 061326ia STA: A.A.28
TOP: Roots of Quadratics

644 ANS: 4 PTS: 2 REF: 081321ia STA: A.A.29
TOP: Set Theory

645 ANS:
(C,B,T), (C,B,5), (C,N,T), (C,N,5), (C,2,T), (C,2,5), (F,B,T), (F,B,5), (F,N,T), (F,N,5), (F,2,T), (F,2,5). 1, 2.

PTS: 4 REF: 081237ia STA: A.S.19 TOP: Sample Space

646 ANS: 3

$$\sqrt{8^2 - 6^2} = \sqrt{28} = \sqrt{4} \sqrt{7} = 2\sqrt{7}$$

PTS: 2 REF: 061329ia STA: A.A.45 TOP: Pythagorean Theorem

647 ANS: 4

$$m = \frac{-3 - 1}{2 - 5} = \frac{-4}{-3} = \frac{4}{3}$$

PTS: 2 REF: 011215ia STA: A.A.33 TOP: Slope

648 ANS: 1 PTS: 2 REF: 011301ia STA: A.S.12

TOP: Scatter Plots

649 ANS: 3 PTS: 2 REF: 011319ia STA: A.N.4

TOP: Operations with Scientific Notation

650 ANS: 1

$$\frac{2x^2 + 10x - 28}{4x + 28} = \frac{2(x^2 + 5x - 14)}{4x + 28} = \frac{2(x + 7)(x - 2)}{4(x + 7)} = \frac{x - 2}{2}$$

PTS: 2 REF: 011327ia STA: A.A.16 TOP: Rational Expressions

KEY: $a > 0$

651 ANS:

$$\frac{(5.9 \times 10.3 \times 1.7) - (6 \times 10 \times 1.5)}{5.9 \times 10.3 \times 1.7} \approx 0.129$$

PTS: 3 REF: 081235ia STA: A.M.3 TOP: Error

KEY: volume and surface area

652 ANS: 2

$$\cos x = \frac{\text{adjacent}}{\text{hypotenuse}} = \frac{16}{20}$$

PTS: 2 REF: 011307ia STA: A.A.42 TOP: Trigonometric Ratios

653 ANS: 4 PTS: 2 REF: 081303ia STA: A.S.22

TOP: Theoretical Probability

654 ANS:

(1,A), (1,B), (1,C), (3,A), (3,B), (3,C), (5,A), (5,B), (5,C), (7,A), (7,B), (7,C), (9,A), (9,B), (9,C). 6

PTS: 3 REF: 011334ia STA: A.S.19 TOP: Sample Space

655 ANS: 2

$$x^2 - 16x + 28 = 0$$

$$(x - 14)(x - 2) = 0$$

$$x = 14, 2$$

PTS: 2 REF: 061311ia STA: A.A.27 TOP: Solving Quadratics by Factoring

656 ANS: 2 PTS: 2 REF: 081318ia STA: A.A.12

TOP: Powers of Powers

657 ANS: 3

$$(3x + 2)(x - 7) = 3x^2 - 21x + 2x - 14 = 3x^2 - 19x - 14$$

PTS: 2 REF: 061210ia STA: A.A.13 TOP: Multiplication of Polynomials

658 ANS:

$$A = P(1 + R)^t = 2000(1 + 0.035)^4 \approx 2295$$

PTS: 2 REF: 081333ia STA: A.A.9 TOP: Exponential Functions

659 ANS: 3

$$b = 3 + d \quad (3 + d)d = 40$$

$$bd = 40 \quad d^2 + 3d - 40 = 0$$

$$(d + 8)(d - 5) = 0$$

$$d = 5$$

PTS: 2 REF: 011208ia STA: A.A.8 TOP: Writing Quadratics

660 ANS: 1 PTS: 2 REF: 011202ia STA: A.A.9

TOP: Exponential Functions

661 ANS: 1

$$3x^2 - 27x = 0$$

$$3x(x - 9) = 0$$

$$x = 0, 9$$

PTS: 2 REF: 011223ia STA: A.A.28 TOP: Roots of Quadratics

662 ANS: 4

$$A = \{1, 3, 5, 7, 9, 11, 13, 15, 17, 19\}$$

PTS: 2 REF: 081306ia STA: A.A.30 TOP: Set Theory

663 ANS: 1

$$rx - st = r$$

$$rx = r + st$$

$$x = \frac{r + st}{r}$$

PTS: 2 REF: 061316ia STA: A.A.23 TOP: Transforming Formulas

- 664 ANS: 4 PTS: 2 REF: 011318ia STA: A.A.29
TOP: Set Theory
- 665 ANS: 3
 $x^2 - 4 = 0$
 $(x + 2)(x - 2) = 0$
 $x = \pm 2$
- PTS: 2 REF: 081225ia STA: A.A.15 TOP: Undefined Rationals
- 666 ANS: 1 PTS: 2 REF: 011311ia STA: A.A.2
TOP: Expressions
- 667 ANS: 4
 $\sin D = \frac{\text{opposite}}{\text{hypotenuse}} = \frac{12}{13}$
- PTS: 2 REF: 061325ia STA: A.A.43 TOP: Using Trigonometry to Find an Angle
- 668 ANS: 4
 $V = \pi r^2 h$
 $32\pi = \pi r^2 (2)$
 $16 = r^2$
 $4 = r$
- PTS: 2 REF: 081224ia STA: A.G.2 TOP: Volume
- 669 ANS: 4
 $\frac{2x^2(x^4 - 9x^2 + 1)}{2x^2}$
- PTS: 2 REF: 081222ia STA: A.A.16 TOP: Rational Expressions
KEY: $a > 0$
- 670 ANS: 2 PTS: 2 REF: 081212ia STA: A.A.5
TOP: Modeling Inequalities
- 671 ANS: 2
 $\frac{20}{3.98} = \frac{180}{x}$
 $20x = 716.4$
 $x = 35.82 \approx 36$
- PTS: 2 REF: 011302ia STA: A.M.1 TOP: Using Rate
- 672 ANS: 3 PTS: 2 REF: 061208ia STA: A.A.31
TOP: Set Theory
- 673 ANS: 4
 $SA = 2lw + 2hw + 2lh = 2(3)(2.2) + 2(7.5)(2.2) + 2(3)(7.5) = 91.2$
- PTS: 2 REF: 081216ia STA: A.G.2 TOP: Surface Area

674 ANS: 2

$$2y + 2w = x$$

$$2w = x - 2y$$

$$w = \frac{x - 2y}{2}$$

PTS: 2

REF: 081330ia

STA: A.A.23

TOP: Transforming Formulas

675 ANS: 3

PTS: 2

REF: 081308ia

STA: A.G.3

TOP: Defining Functions

KEY: graphs

676 ANS:

$$\frac{3x(x+3)}{(x+3)(x+2)} \times \frac{(x-3)(x+2)}{(x+3)(x-3)} = \frac{3x}{x+3}$$

PTS: 4

REF: 081338ia

STA: A.A.18

TOP: Multiplication and Division of Rationals

KEY: division

677 ANS: 4

PTS: 2

REF: 061320ia

STA: A.G.6

TOP: Linear Inequalities

678 ANS: 1

PTS: 2

REF: 061204ia

STA: A.A.1

TOP: Expressions

679 ANS:

$$\frac{5}{8} \times \frac{3}{7} = \frac{15}{56} \cdot \frac{5}{8} \times \frac{4}{7} = \frac{20}{56} \cdot \frac{20}{56} + \frac{3}{8} \times \frac{2}{7} = \frac{26}{56}$$

PTS: 4

REF: 061338ia

STA: A.S.23

TOP: Theoretical Probability

KEY: dependent events

680 ANS: 1

$$\cos A = \frac{\text{adjacent}}{\text{hypotenuse}} = \frac{3}{5}$$

PTS: 2

REF: 081329ia

STA: A.A.42

TOP: Trigonometric Ratios

681 ANS: 2

PTS: 2

REF: 061314ia

STA: A.S.6

TOP: Box-and-Whisker Plots

682 ANS: 1

$$-3x + 8 \geq 14$$

$$-3x \geq 6$$

$$x \leq -2$$

PTS: 2

REF: 081309ia

STA: A.A.21

TOP: Interpreting Solutions

683 ANS: 3

$$\frac{4}{3a} - \frac{5}{2a} = \frac{8}{6a} - \frac{15}{6a} = -\frac{7}{6a}$$

PTS: 2

REF: 081328ia

STA: A.A.17

TOP: Addition and Subtraction of Rationals

684 ANS: 3

PTS: 2

REF: 061306ia

STA: A.G.8

TOP: Solving Quadratics by Graphing

- 685 ANS: 3
 $A \cup C = \{1, 2, 3, 5, 7, 9\}$
- PTS: 2 REF: 081221ia STA: A.A.31 TOP: Set Theory
- 686 ANS: 4 PTS: 2 REF: 011229ia STA: A.S.8
 TOP: Scatter Plots
- 687 ANS:
 $5x^3 - 20x^2 - 60x$
 $5x(x^2 - 4x - 12)$
 $5x(x + 2)(x - 6)$
- PTS: 2 REF: 011332ia STA: A.A.20 TOP: Factoring Polynomials
- 688 ANS: 2 PTS: 2 REF: 011227ia STA: A.A.3
 TOP: Expressions
- 689 ANS: 1 PTS: 2 REF: 081315ia STA: A.A.10
 TOP: Solving Linear Systems
- 690 ANS:
 $259.99 \times 1.07 - 259.99(1 - 0.3) \times 1.07 = 83.46$
- PTS: 4 REF: 011239ia STA: A.N.5 TOP: Percents
- 691 ANS: 1 PTS: 2 REF: 061310ia STA: A.A.29
 TOP: Set Theory
- 692 ANS: 1
 $x^2 - 5x + 3 = x - 6 \quad y = 3 - 6 = -3 \quad (3, -3)$
 $x^2 - 6x + 9 = 0$
 $(x - 3)^2 = 0$
 $x = 3$
- PTS: 2 REF: 061330ia STA: A.G.9 TOP: Quadratic-Linear Systems
- 693 ANS: 4
 $5.5 \text{ g} \times \frac{4 \text{ q}}{1 \text{ g}} \times \frac{32 \text{ oz}}{1 \text{ q}} = 704 \text{ oz}$
- PTS: 2 REF: 061305ia STA: A.M.2 TOP: Conversions
 KEY: dimensional analysis
- 694 ANS:
 $V = \pi r^2 h = \pi \cdot 6.5^2 \cdot 24 = 1014\pi$
- PTS: 2 REF: 061332ia STA: A.G.2 TOP: Volume
- 695 ANS: 4
 $m = \frac{-A}{B} = \frac{-4}{3}$
- PTS: 2 REF: 061319ia STA: A.A.37 TOP: Slope

696 ANS: 3 PTS: 2 REF: 011205ia STA: A.A.1
TOP: Expressions

697 ANS: 2 PTS: 2 REF: 061205ia STA: A.S.12
TOP: Scatter Plots

698 ANS: 2 PTS: 2 REF: 081305ia STA: A.A.1
TOP: Expressions

699 ANS: 2
To determine student opinion, survey the widest range of students.

PTS: 2 REF: 011313ia STA: A.S.3 TOP: Analysis of Data

700 ANS: 2
 $A = \{4, 9, 16, 25, 36, 49, 64, 81, 100\}$

PTS: 2 REF: 011326ia STA: A.A.30 TOP: Set Theory

701 ANS: 3 PTS: 2 REF: 081211ia STA: A.A.9
TOP: Exponential Functions

702 ANS:

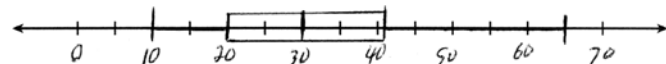

. Three scores are above 41.

PTS: 4 REF: 011337ia STA: A.S.5 TOP: Box-and-Whisker Plots