

JMAP REGENTS BY TYPE

The NY Geometry Regents Exams
Fall 2008-August 2013

www.jmap.org

Geometry Multiple Choice Regents Exam Questions

- 1 In $\triangle ABC$, D is the midpoint of \overline{AB} and E is the midpoint of \overline{BC} . If $AC = 3x - 15$ and $DE = 6$, what is the value of x ?

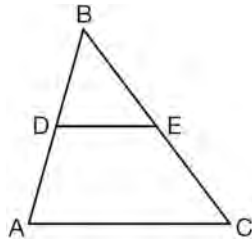

- 1) 6
2) 7
3) 9
4) 12
- 2 What is the slope of the line perpendicular to the line represented by the equation $2x + 4y = 12$?
- 1) -2
2) 2
3) $-\frac{1}{2}$
4) $\frac{1}{2}$
- 3 What is the equation of a line passing through the point $(6, 1)$ and parallel to the line whose equation is $3x = 2y + 4$?
- 1) $y = -\frac{2}{3}x + 5$
2) $y = -\frac{2}{3}x - 3$
3) $y = \frac{3}{2}x - 8$
4) $y = \frac{3}{2}x - 5$

- 4 In the diagram of trapezoid $ABCD$ below, $\overline{AB} \parallel \overline{DC}$, $\overline{AD} \cong \overline{BC}$, $m\angle A = 4x + 20$, and $m\angle C = 3x - 15$.

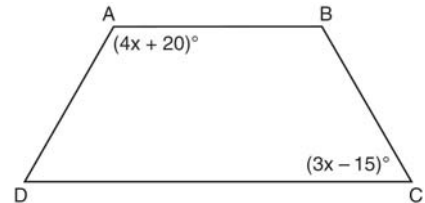

What is $m\angle D$?

- 1) 25
2) 35
3) 60
4) 90
- 5 The equation of a line is $y = \frac{2}{3}x + 5$. What is an equation of the line that is perpendicular to the given line and that passes through the point $(4, 2)$?
- 1) $y = \frac{2}{3}x - \frac{2}{3}$
2) $y = \frac{3}{2}x - 4$
3) $y = -\frac{3}{2}x + 7$
4) $y = -\frac{3}{2}x + 8$
- 6 Chords \overline{AB} and \overline{CD} intersect at point E in a circle with center at O . If $AE = 8$, $AB = 20$, and $DE = 16$, what is the length of \overline{CE} ?
- 1) 6
2) 9
3) 10
4) 12

Geometry Multiple Choice Regents Exam Questions

www.jmap.org

- 7 Which equation represents circle A shown in the diagram below?

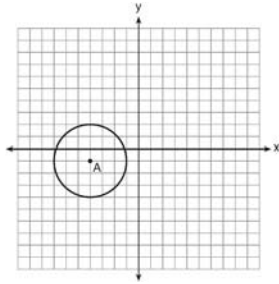

- 1) $(x - 4)^2 + (y - 1)^2 = 3$
- 2) $(x + 4)^2 + (y + 1)^2 = 3$
- 3) $(x - 4)^2 + (y - 1)^2 = 9$
- 4) $(x + 4)^2 + (y + 1)^2 = 9$

- 8 As shown in the diagram of rectangle $ABCD$ below, diagonals \overline{AC} and \overline{BD} intersect at E .

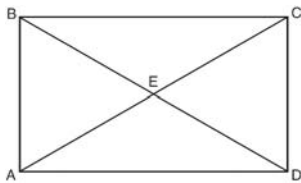

If $\overline{AE} = x + 2$ and $\overline{BD} = 4x - 16$, then the length of \overline{AC} is

- 1) 6
- 2) 10
- 3) 12
- 4) 24

- 9 In $\triangle ABC$, $m\angle A = 60$, $m\angle B = 80$, and $m\angle C = 40$. Which inequality is true?

- 1) $\overline{AB} > \overline{BC}$
- 2) $\overline{AC} > \overline{BC}$
- 3) $\overline{AC} < \overline{BA}$
- 4) $\overline{BC} < \overline{BA}$

- 10 The volume of a sphere is approximately 44.6022 cubic centimeters. What is the radius of the sphere, to the nearest tenth of a centimeter?

- 1) 2.2
- 2) 3.3
- 3) 4.4
- 4) 4.7

- 11 What is the perimeter of a rhombus whose diagonals are 16 and 30?

- 1) 92
- 2) 68
- 3) 60
- 4) 17

- 12 The sides of a triangle are 8, 12, and 15. The longest side of a similar triangle is 18. What is the ratio of the perimeter of the smaller triangle to the perimeter of the larger triangle?

- 1) 2:3
- 2) 4:9
- 3) 5:6
- 4) 25:36

- 13 If $\triangle MNP \cong \triangle VWX$ and \overline{PM} is the shortest side of $\triangle MNP$, what is the shortest side of $\triangle VWX$?

- 1) \overline{XV}
- 2) \overline{WX}
- 3) \overline{VW}
- 4) \overline{NP}

- 14 Which graph could be used to find the solution to the following system of equations?

$$y = (x + 3)^2 - 1$$

$$x + y = 2$$

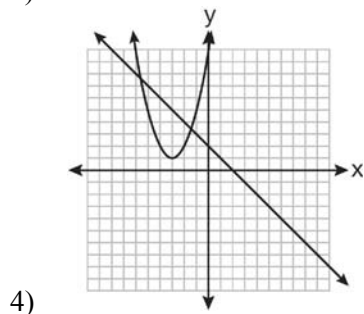
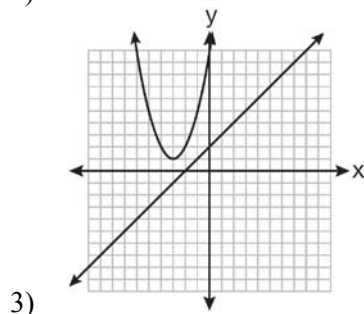
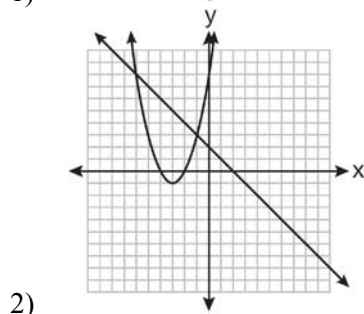
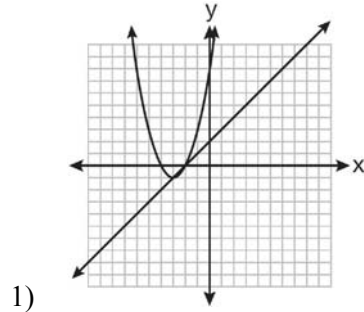

- 15 The equations $x^2 + y^2 = 25$ and $y = 5$ are graphed on a set of axes. What is the solution of this system?

- 1) $(0, 0)$
- 2) $(5, 0)$
- 3) $(0, 5)$
- 4) $(5, 5)$

- 16 When the system of equations $y + 2 = (x - 4)^2$ and $2x + y - 6 = 0$ is solved graphically, the solution is

- 1) $(-4, -2)$ and $(-2, 2)$
- 2) $(4, -2)$ and $(2, 2)$
- 3) $(-4, 2)$ and $(-6, 6)$
- 4) $(4, 2)$ and $(6, 6)$

- 17 Triangle ABC has the coordinates $A(1, 2)$, $B(5, 2)$, and $C(5, 5)$. Triangle ABC is rotated 180° about the origin to form triangle $A'B'C'$. Triangle $A'B'C'$ is

- 1) acute
- 2) isosceles
- 3) obtuse
- 4) right

- 18 Triangle ABC has vertices $A(0, 0)$, $B(6, 8)$, and $C(8, 4)$. Which equation represents the perpendicular bisector of \overline{BC} ?

- 1) $y = 2x - 6$
- 2) $y = -2x + 4$
- 3) $y = \frac{1}{2}x + \frac{5}{2}$
- 4) $y = -\frac{1}{2}x + \frac{19}{2}$

- 19 Given: $\triangle ABD$, \overline{BC} is the perpendicular bisector of \overline{AD}

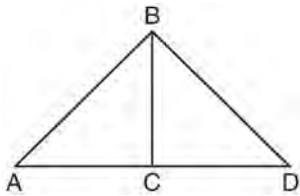

Which statement can *not* always be proven?

- 1) $\overline{AC} \cong \overline{DC}$
 - 2) $\overline{BC} \cong \overline{CD}$
 - 3) $\angle ACB \cong \angle DCB$
 - 4) $\triangle ABC \cong \triangle DBC$
- 20 Points $A(5, 3)$ and $B(7, 6)$ lie on \overleftrightarrow{AB} . Points $C(6, 4)$ and $D(9, 0)$ lie on \overleftrightarrow{CD} . Which statement is true?

- 1) $\overleftrightarrow{AB} \parallel \overleftrightarrow{CD}$
- 2) $\overleftrightarrow{AB} \perp \overleftrightarrow{CD}$
- 3) \overleftrightarrow{AB} and \overleftrightarrow{CD} are the same line.
- 4) \overleftrightarrow{AB} and \overleftrightarrow{CD} intersect, but are not perpendicular.

- 21 What is the difference between the sum of the measures of the interior angles of a regular pentagon and the sum of the measures of the exterior angles of a regular pentagon?
- 1) 36
 - 2) 72
 - 3) 108
 - 4) 180

- 22 In the diagram of $\triangle ABC$ below, medians \overline{AD} and \overline{BE} intersect at point F .

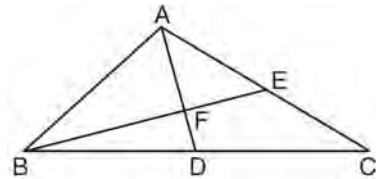

If $AF = 6$, what is the length of \overline{FD} ?

- 1) 6
 - 2) 2
 - 3) 3
 - 4) 9
- 23 In the diagram below of circle O , \overline{PAC} and \overline{PBD} are secants.

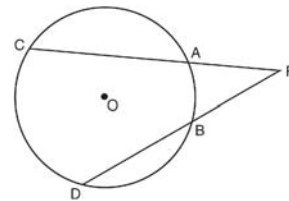

If $m\widehat{CD} = 70$ and $m\widehat{AB} = 20$, what is the degree measure of $\angle P$?

- 1) 25
 - 2) 35
 - 3) 45
 - 4) 50
- 24 In $\triangle ABC$, $\angle A \cong \angle B$ and $\angle C$ is an obtuse angle. Which statement is true?
- 1) $\overline{AC} \cong \overline{AB}$ and \overline{BC} is the longest side.
 - 2) $\overline{AC} \cong \overline{BC}$ and \overline{AB} is the longest side.
 - 3) $\overline{AC} \cong \overline{AB}$ and \overline{BC} is the shortest side.
 - 4) $\overline{AC} \cong \overline{BC}$ and \overline{AB} is the shortest side.

- 25 The diagram below shows $\triangle ABD$, with \overline{ABC} , $\overline{BE} \perp \overline{AD}$, and $\angle EBD \cong \angle CBD$.

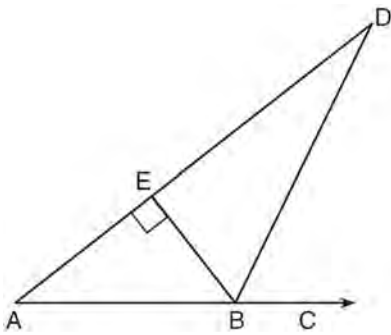

If $m\angle ABE = 52$, what is $m\angle D$?

- 1) 26
- 2) 38
- 3) 52
- 4) 64

- 26 Triangle ABC is shown in the diagram below.

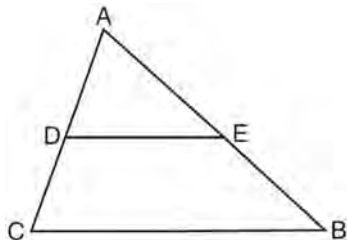

If \overline{DE} joins the midpoints of \overline{ADC} and \overline{AEB} , which statement is *not* true?

- 1) $DE = \frac{1}{2} CB$
- 2) $\overline{DE} \parallel \overline{CB}$
- 3) $\frac{AD}{DC} = \frac{DE}{CB}$
- 4) $\triangle ABC \sim \triangle AED$

- 27 As shown in the diagram below, when right triangle DAB is reflected over the x -axis, its image is triangle DCB .

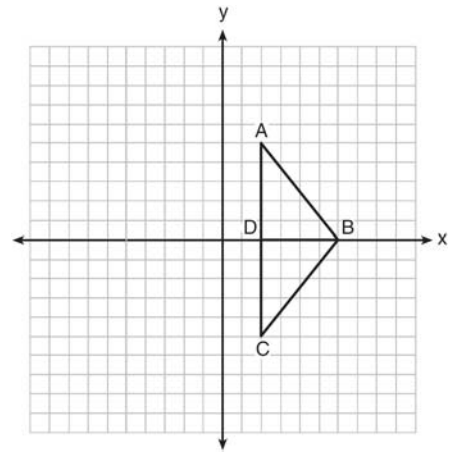

Which statement justifies why $\overline{AB} \cong \overline{CB}$?

- 1) Distance is preserved under reflection.
- 2) Orientation is preserved under reflection.
- 3) Points on the line of reflection remain invariant.
- 4) Right angles remain congruent under reflection.

- 28 The equation of a circle is $(x - 2)^2 + (y + 5)^2 = 32$. What are the coordinates of the center of this circle and the length of its radius?

- 1) $(-2, 5)$ and 16
- 2) $(2, -5)$ and 16
- 3) $(-2, 5)$ and $4\sqrt{2}$
- 4) $(2, -5)$ and $4\sqrt{2}$

Geometry Multiple Choice Regents Exam Questions

www.jmap.org

- 29 In a coordinate plane, the locus of points 5 units from the x -axis is the
- 1) lines $x = 5$ and $x = -5$
 - 2) lines $y = 5$ and $y = -5$
 - 3) line $x = 5$, only
 - 4) line $y = 5$, only

- 30 What is the equation of circle O shown in the diagram below?

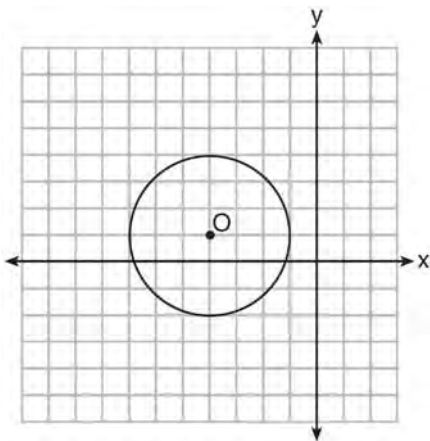

- 1) $(x + 4)^2 + (y - 1)^2 = 3$
 - 2) $(x - 4)^2 + (y + 1)^2 = 3$
 - 3) $(x + 4)^2 + (y - 1)^2 = 9$
 - 4) $(x - 4)^2 + (y + 1)^2 = 9$
- 31 What are the coordinates of A' , the image of $A(-3, 4)$, after a rotation of 180° about the origin?
- 1) $(4, -3)$
 - 2) $(-4, -3)$
 - 3) $(3, 4)$
 - 4) $(3, -4)$

- 32 Which set of numbers could *not* represent the lengths of the sides of a right triangle?

- 1) $\{1, 3, \sqrt{10}\}$
- 2) $\{2, 3, 4\}$
- 3) $\{3, 4, 5\}$
- 4) $\{8, 15, 17\}$

- 33 Transversal \overleftrightarrow{EF} intersects \overleftrightarrow{AB} and \overleftrightarrow{CD} , as shown in the diagram below.

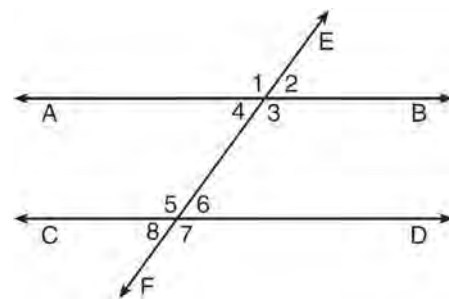

Which statement could always be used to prove

$\overleftrightarrow{AB} \parallel \overleftrightarrow{CD}$?

- 1) $\angle 2 \cong \angle 4$
 - 2) $\angle 7 \cong \angle 8$
 - 3) $\angle 3$ and $\angle 6$ are supplementary
 - 4) $\angle 1$ and $\angle 5$ are supplementary
- 34 Point A is on line m . How many distinct planes will be perpendicular to line m and pass through point A ?
- 1) one
 - 2) two
 - 3) zero
 - 4) infinite

- 35 Which graph represents a circle whose equation is $x^2 + (y - 1)^2 = 9$?

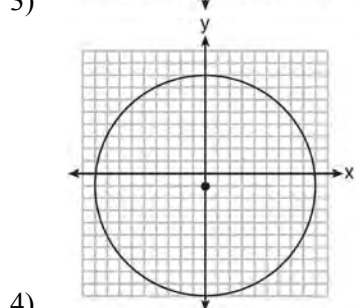
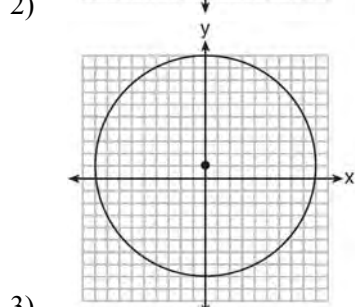
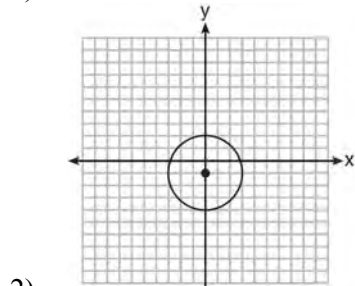
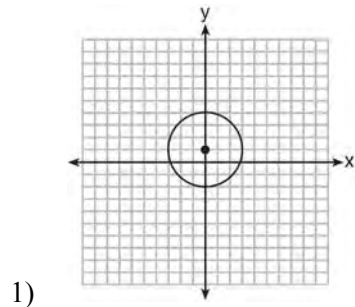

- 36 The diagram below shows the construction of line m , parallel to line ℓ , through point P .

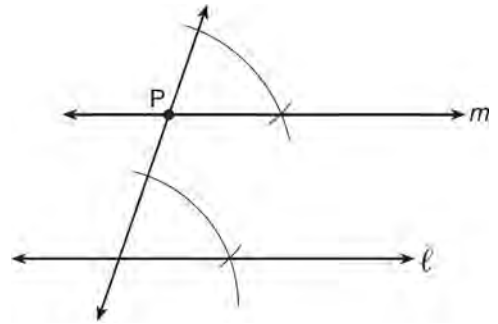

Which theorem was used to justify this construction?

- 1) If two lines are cut by a transversal and the alternate interior angles are congruent, the lines are parallel.
 - 2) If two lines are cut by a transversal and the interior angles on the same side are supplementary, the lines are parallel.
 - 3) If two lines are perpendicular to the same line, they are parallel.
 - 4) If two lines are cut by a transversal and the corresponding angles are congruent, they are parallel.
- 37 As shown in the diagram below, \overline{CD} is a median of $\triangle ABC$.

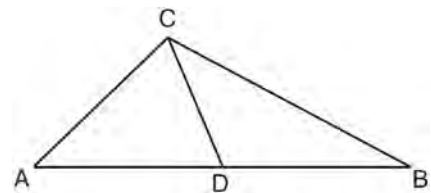

Which statement is *always* true?

- 1) $\overline{AD} \cong \overline{DB}$
- 2) $\overline{AC} \cong \overline{AD}$
- 3) $\angle ACD \cong \angle CDB$
- 4) $\angle BCD \cong \angle ACD$

- 38 If the vertices of $\triangle ABC$ are $A(-2, 4)$, $B(-2, 8)$, and $C(-5, 6)$, then $\triangle ABC$ is classified as
- 1) right
 - 2) scalene
 - 3) isosceles
 - 4) equilateral

- 39 Triangle $\triangle ABC$ shown below is a right triangle with altitude \overline{AD} drawn to the hypotenuse \overline{BC} .

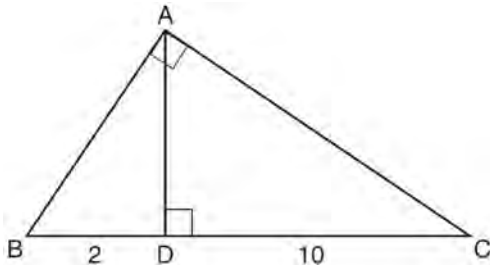

If $BD = 2$ and $DC = 10$, what is the length of \overline{AB} ?

- 1) $2\sqrt{2}$
 - 2) $2\sqrt{5}$
 - 3) $2\sqrt{6}$
 - 4) $2\sqrt{30}$
- 40 A rectangular prism has a base with a length of 25, a width of 9, and a height of 12. A second prism has a square base with a side of 15. If the volumes of the two prisms are equal, what is the height of the second prism?
- 1) 6
 - 2) 8
 - 3) 12
 - 4) 15

- 41 In the diagram of $\triangle UVW$ below, A is the midpoint of \overline{UV} , B is the midpoint of \overline{UW} , C is the midpoint of \overline{VW} , and \overline{AB} and \overline{AC} are drawn.

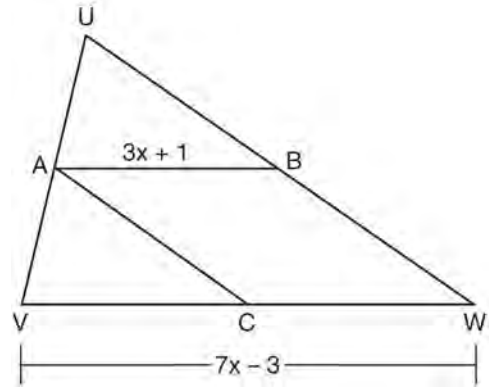

If $\overline{VW} = 7x - 3$ and $\overline{AB} = 3x + 1$, what is the length of \overline{VC} ?

- 1) 5
 - 2) 13
 - 3) 16
 - 4) 32
- 42 The diagram below shows the construction of an equilateral triangle.

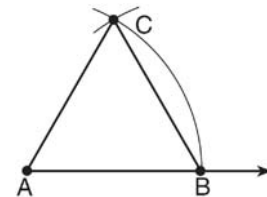

Which statement justifies this construction?

- 1) $\angle A + \angle B + \angle C = 180$
- 2) $m\angle A = m\angle B = m\angle C$
- 3) $\overline{AB} = \overline{AC} = \overline{BC}$
- 4) $\overline{AB} + \overline{BC} > \overline{AC}$

Geometry Multiple Choice Regents Exam Questions

www.jmap.org

- 43 Triangle ABC is similar to triangle DEF . The lengths of the sides of $\triangle ABC$ are 5, 8, and 11. What is the length of the shortest side of $\triangle DEF$ if its perimeter is 60?
- 1) 10
 - 2) 12.5
 - 3) 20
 - 4) 27.5

- 44 In the diagram of circle O below, chord \overline{CD} is parallel to diameter \overline{AOB} and $m\widehat{CD} = 110$.

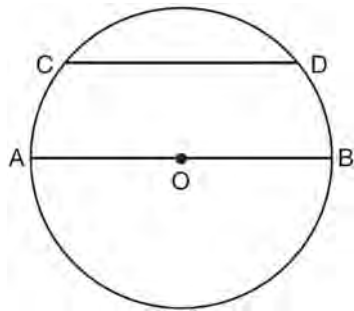

What is $m\widehat{DB}$?

- 1) 35
 - 2) 55
 - 3) 70
 - 4) 110
- 45 Secants \overline{JKL} and \overline{JMN} are drawn to circle O from an external point, J . If $JK = 8$, $LK = 4$, and $JM = 6$, what is the length of JN ?
- 1) 16
 - 2) 12
 - 3) 10
 - 4) 8

- 46 If line ℓ is perpendicular to distinct planes \mathcal{P} and \mathcal{Q} , then planes \mathcal{P} and \mathcal{Q}
- 1) are parallel
 - 2) contain line ℓ
 - 3) are perpendicular
 - 4) intersect, but are *not* perpendicular

- 47 Lines m and n are in plane \mathcal{A} . What is the converse of the statement “If lines m and n are parallel, then lines m and n do not intersect”?
- 1) If lines m and n are not parallel, then lines m and n intersect.
 - 2) If lines m and n are not parallel, then lines m and n do not intersect
 - 3) If lines m and n intersect, then lines m and n are not parallel.
 - 4) If lines m and n do not intersect, then lines m and n are parallel.

- 48 In right triangle ABC shown in the diagram below, altitude \overline{BD} is drawn to hypotenuse \overline{AC} , $CD = 12$, and $AD = 3$.

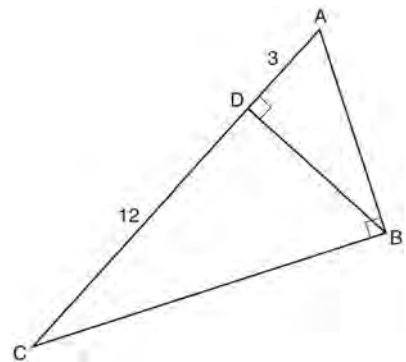

What is the length of \overline{AB} ?

- 1) $5\sqrt{3}$
- 2) 6
- 3) $3\sqrt{5}$
- 4) 9

Geometry Multiple Choice Regents Exam Questions

www.jmap.org

49 Which set of equations represents two circles that have the same center?

- 1) $x^2 + (y + 4)^2 = 16$ and $(x + 4)^2 + y^2 = 16$
- 2) $(x + 3)^2 + (y - 3)^2 = 16$ and $(x - 3)^2 + (y + 3)^2 = 25$
- 3) $(x - 7)^2 + (y - 2)^2 = 16$ and $(x + 7)^2 + (y + 2)^2 = 25$
- 4) $(x - 2)^2 + (y - 5)^2 = 16$ and $(x - 2)^2 + (y - 5)^2 = 25$

50 How many points are 5 units from a line and also equidistant from two points on the line?

- 1) 1
- 2) 2
- 3) 3
- 4) 0

51 In circle R shown below, diameter \overline{DE} is perpendicular to chord \overline{ST} at point L .

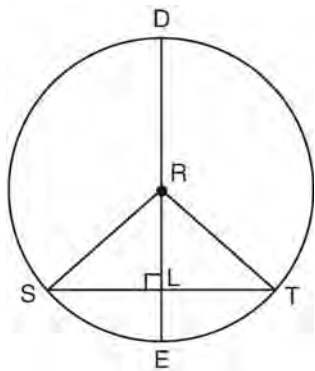

Which statement is *not* always true?

- 1) $\overline{SL} \cong \overline{TL}$
- 2) $\overline{RS} = \overline{DR}$
- 3) $\overline{RL} \cong \overline{LE}$
- 4) $(DL)(LE) = (SL)(LT)$

52 The measure of an interior angle of a regular polygon is 120° . How many sides does the polygon have?

- 1) 5
- 2) 6
- 3) 3
- 4) 4

53 The bases of a right triangular prism are $\triangle ABC$ and $\triangle DEF$. Angles A and D are right angles, $AB = 6$, $AC = 8$, and $AD = 12$. What is the length of edge \overline{BE} ?

- 1) 10
- 2) 12
- 3) 14
- 4) 16

54 In the diagram below, under which transformation is $\triangle A'B'C'$ the image of $\triangle ABC$?

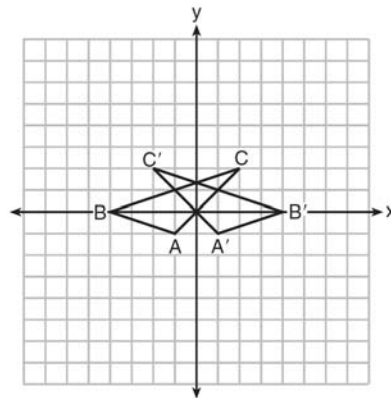

- 1) D_2
- 2) $r_{x\text{-axis}}$
- 3) $r_{y\text{-axis}}$
- 4) $(x, y) \rightarrow (x - 2, y)$

Geometry Multiple Choice Regents Exam Questions

www.jmap.org

- 55 In circle O , diameter \overline{AB} intersects chord \overline{CD} at E . If $CE = ED$, then $\angle CEA$ is which type of angle?
- 1) straight
 - 2) obtuse
 - 3) acute
 - 4) right

- 56 In the diagram of $\triangle ABC$ below, \overline{AB} is extended to point D .

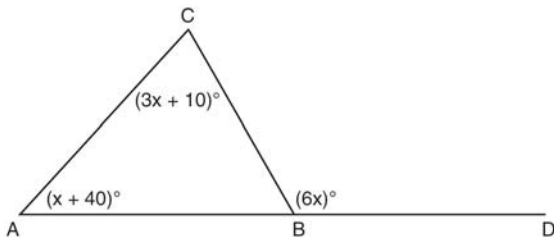

If $m\angle CAB = x + 40$, $m\angle ACB = 3x + 10$, $m\angle CBD = 6x$, what is $m\angle CAB$?

- 1) 13
 - 2) 25
 - 3) 53
 - 4) 65
- 57 In trapezoid $RSTV$ with bases \overline{RS} and \overline{VT} , diagonals \overline{RT} and \overline{SV} intersect at Q .

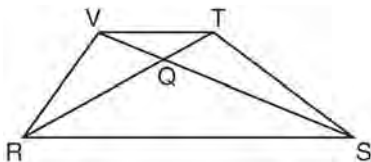

If trapezoid $RSTV$ is *not* isosceles, which triangle is equal in area to $\triangle RSV$?

- 1) $\triangle RQV$
- 2) $\triangle RST$
- 3) $\triangle RVT$
- 4) $\triangle SVT$

- 58 In the diagram below, \overline{AC} and \overline{AD} are tangent to circle B at points C and D , respectively, and \overline{BC} , \overline{BD} , and \overline{BA} are drawn.

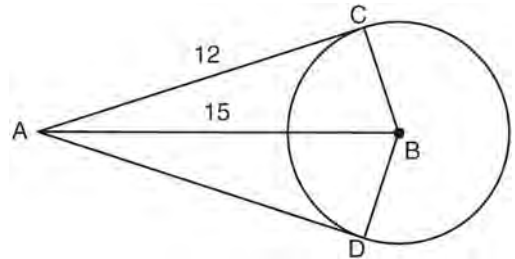

If $AC = 12$ and $AB = 15$, what is the length of \overline{BD} ?

- 1) 5.5
 - 2) 9
 - 3) 12
 - 4) 18
- 59 If $\triangle ABC \cong \triangle JKL \cong \triangle RST$, then \overline{BC} must be congruent to
- 1) \overline{JL}
 - 2) \overline{JK}
 - 3) \overline{ST}
 - 4) \overline{RS}

- 60 Consider the relationship between the two statements below.

$$\text{If } \sqrt{16+9} \neq 4+3, \text{ then } 5 \neq 4+3$$

$$\text{If } \sqrt{16+9} = 4+3, \text{ then } 5 = 4+3$$

These statements are

- 1) inverses
- 2) converses
- 3) contrapositives
- 4) biconditionals

Geometry Multiple Choice Regents Exam Questions

www.jmap.org

- 61 A student wrote the following equations:

$$3y + 6 = 2x$$

$$2y - 3x = 6$$

The lines represented by these equations are

- 1) parallel
 - 2) the same line
 - 3) perpendicular
 - 4) intersecting, but *not* perpendicular
- 62 In a park, two straight paths intersect. The city wants to install lampposts that are both equidistant from each path and also 15 feet from the intersection of the paths. How many lampposts are needed?
- 1) 1
 - 2) 2
 - 3) 3
 - 4) 4
- 63 Square $ABCD$ has vertices $A(-2, -3)$, $B(4, -1)$, $C(2, 5)$, and $D(-4, 3)$. What is the length of a side of the square?
- 1) $2\sqrt{5}$
 - 2) $2\sqrt{10}$
 - 3) $4\sqrt{5}$
 - 4) $10\sqrt{2}$
- 64 What is the converse of “If an angle measures 90 degrees, then it is a right angle”?
- 1) If an angle is a right angle, then it measures 90 degrees.
 - 2) An angle is a right angle if it measures 90 degrees.
 - 3) If an angle is not a right angle, then it does not measure 90 degrees.
 - 4) If an angle does not measure 90 degrees, then it is not a right angle.

- 65 Two prisms have equal heights and equal volumes. The base of one is a pentagon and the base of the other is a square. If the area of the pentagonal base is 36 square inches, how many inches are in the length of each side of the square base?

- 1) 6
- 2) 9
- 3) 24
- 4) 36

- 66 What is an equation of the circle with center $(-5, 4)$ and a radius of 7?

- 1) $(x - 5)^2 + (y + 4)^2 = 14$
- 2) $(x - 5)^2 + (y + 4)^2 = 49$
- 3) $(x + 5)^2 + (y - 4)^2 = 14$
- 4) $(x + 5)^2 + (y - 4)^2 = 49$

- 67 What are the coordinates of the center of a circle if the endpoints of its diameter are $A(8, -4)$ and $B(-3, 2)$?

- 1) $(2.5, 1)$
- 2) $(2.5, -1)$
- 3) $(5.5, -3)$
- 4) $(5.5, 3)$

- 68 The lateral area of a right circular cone is equal to $120\pi \text{ cm}^2$. If the base of the cone has a diameter of 24 cm, what is the length of the slant height, in centimeters?

- 1) 2.5
- 2) 5
- 3) 10
- 4) 15.7

- 69 Plane \mathcal{A} and plane \mathcal{B} are two distinct planes that are both perpendicular to line ℓ . Which statement about planes \mathcal{A} and \mathcal{B} is true?
- 1) Planes \mathcal{A} and \mathcal{B} have a common edge, which forms a line.
 - 2) Planes \mathcal{A} and \mathcal{B} are perpendicular to each other.
 - 3) Planes \mathcal{A} and \mathcal{B} intersect each other at exactly one point.
 - 4) Planes \mathcal{A} and \mathcal{B} are parallel to each other.

- 70 Circle O with $\angle AOC$ and $\angle ABC$ is shown in the diagram below.

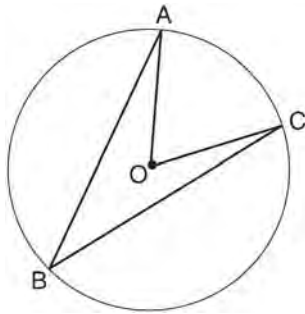

What is the ratio of $m\angle AOC$ to $m\angle ABC$?

- 1) 1 : 1
 - 2) 2 : 1
 - 3) 3 : 1
 - 4) 1 : 2
- 71 Given the statement: One is a prime number. What is the negation and the truth value of the negation?
- 1) One is not a prime number; true
 - 2) One is not a prime number; false
 - 3) One is a composite number; true
 - 4) One is a composite number; false

- 72 Which graph represents a circle whose equation is $x^2 + (y - 2)^2 = 4$?

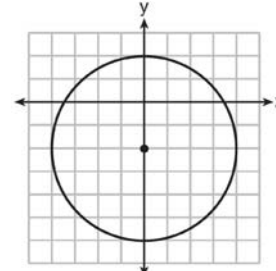
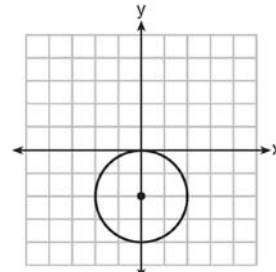
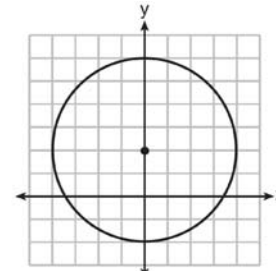
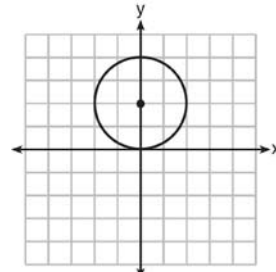

- 73 In circle O shown in the diagram below, chords \overline{AB} and \overline{CD} are parallel.

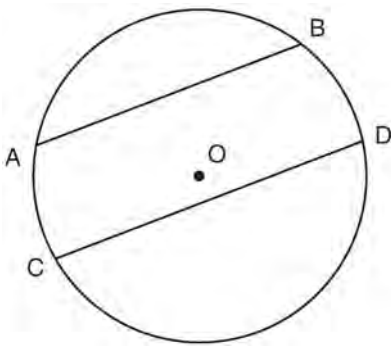

If $m\widehat{AB} = 104$ and $m\widehat{CD} = 168$, what is $m\widehat{BD}$?

- 1) 38
 - 2) 44
 - 3) 88
 - 4) 96
- 74 Based on the construction below, which conclusion is *not* always true?

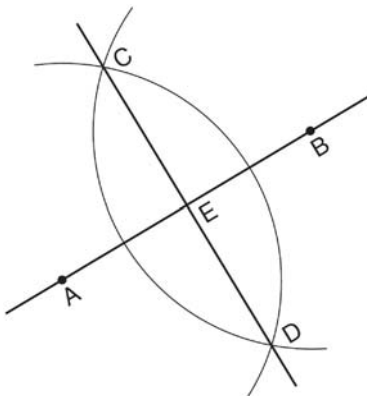

- 1) $\overline{AB} \perp \overline{CD}$
- 2) $\overline{AB} = \overline{CD}$
- 3) $\overline{AE} = \overline{EB}$
- 4) $\overline{CE} = \overline{DE}$

- 75 In the diagram below, $\triangle XYV \cong \triangle TSV$.

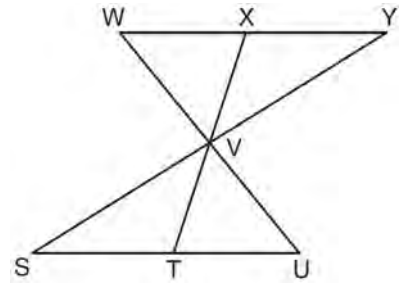

Which statement can *not* be proven?

- 1) $\angle XVY \cong \angle TVS$
 - 2) $\angle VYX \cong \angle VUT$
 - 3) $\overline{XY} \cong \overline{TS}$
 - 4) $\overline{YV} \cong \overline{SV}$
- 76 Which equation represents a line that is parallel to the line whose equation is $3x - 2y = 7$?
- 1) $y = -\frac{3}{2}x + 5$
 - 2) $y = -\frac{2}{3}x + 4$
 - 3) $y = \frac{3}{2}x - 5$
 - 4) $y = \frac{2}{3}x - 4$
- 77 In $\triangle ABC$, $m\angle A = 3x + 1$, $m\angle B = 4x - 17$, and $m\angle C = 5x - 20$. Which type of triangle is $\triangle ABC$?

- 1) right
- 2) scalene
- 3) isosceles
- 4) equilateral

- 78 What is the equation for circle O shown in the graph below?

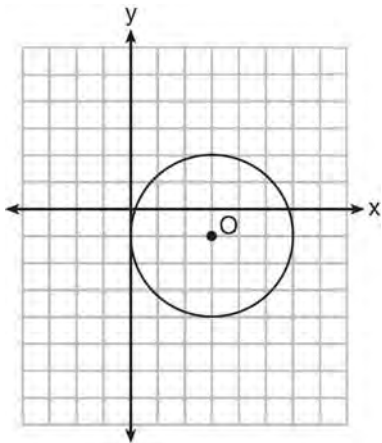

- 1) $(x - 3)^2 + (y + 1)^2 = 6$
- 2) $(x + 3)^2 + (y - 1)^2 = 6$
- 3) $(x - 3)^2 + (y + 1)^2 = 9$
- 4) $(x + 3)^2 + (y - 1)^2 = 9$

- 79 In the diagram below of right triangle ABC , altitude CD is drawn to hypotenuse AB .

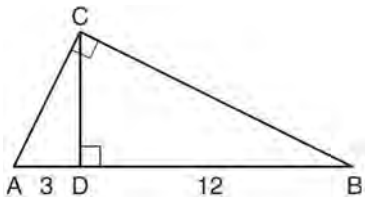

If $AD = 3$ and $DB = 12$, what is the length of altitude CD ?

- 1) 6
- 2) $6\sqrt{5}$
- 3) 3
- 4) $3\sqrt{5}$

- 80 As shown in the diagram below, \overline{FD} and \overline{CB} intersect at point A and \overline{ET} is perpendicular to both \overline{FD} and \overline{CB} at A .

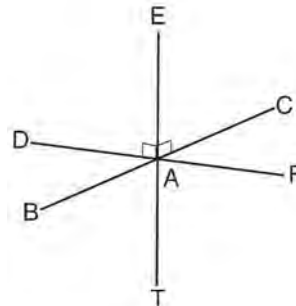

Which statement is *not* true?

- 1) \overline{ET} is perpendicular to plane BAD .
- 2) \overline{ET} is perpendicular to plane FAB .
- 3) \overline{ET} is perpendicular to plane CAD .
- 4) \overline{ET} is perpendicular to plane BAT .

- 81 As shown in the diagram below, a right pyramid has a square base, $ABCD$, and \overline{EF} is the slant height.

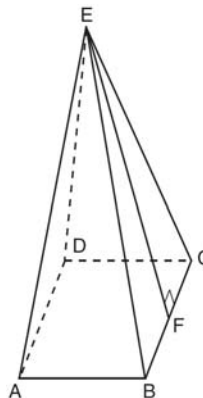

Which statement is *not* true?

- 1) $\overline{EA} \cong \overline{EC}$
- 2) $\overline{EB} \cong \overline{EF}$
- 3) $\triangle AEB \cong \triangle BEC$
- 4) $\triangle CED$ is isosceles

Geometry Multiple Choice Regents Exam Questions

- 82 In the diagram below, \overleftrightarrow{AB} is perpendicular to plane $AEFG$.

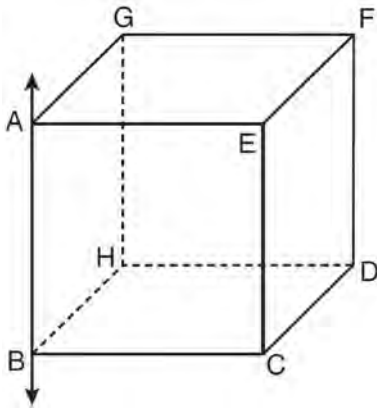

Which plane must be perpendicular to plane $AEFG$?

- 1) $ABCE$
 - 2) $BCDH$
 - 3) $CDFE$
 - 4) $HDFG$
- 83 If $\triangle JKL \cong \triangle MNO$, which statement is always true?
- 1) $\angle KLJ \cong \angle NMO$
 - 2) $\angle KJL \cong \angle MON$
 - 3) $\overline{JL} \cong \overline{MO}$
 - 4) $\overline{JK} \cong \overline{ON}$
- 84 What is the length of the line segment whose endpoints are $A(-1, 9)$ and $B(7, 4)$?
- 1) $\sqrt{61}$
 - 2) $\sqrt{89}$
 - 3) $\sqrt{205}$
 - 4) $\sqrt{233}$

- 85 The diagram below shows the construction of \overleftrightarrow{AB} through point P parallel to \overleftrightarrow{CD} .

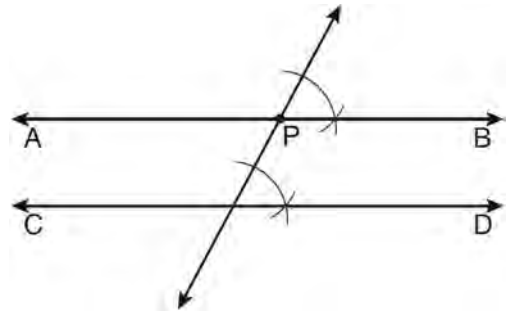

Which theorem justifies this method of construction?

- 1) If two lines in a plane are perpendicular to a transversal at different points, then the lines are parallel.
 - 2) If two lines in a plane are cut by a transversal to form congruent corresponding angles, then the lines are parallel.
 - 3) If two lines in a plane are cut by a transversal to form congruent alternate interior angles, then the lines are parallel.
 - 4) If two lines in a plane are cut by a transversal to form congruent alternate exterior angles, then the lines are parallel.
- 86 Which type of triangle can be drawn using the points $(-2, 3)$, $(-2, -7)$, and $(4, -5)$?
- 1) scalene
 - 2) isosceles
 - 3) equilateral
 - 4) no triangle can be drawn

Geometry Multiple Choice Regents Exam Questions

www.jmap.org

87 In $\triangle RST$, $m\angle R = 58$ and $m\angle S = 73$. Which inequality is true?

- 1) $RT < TS < RS$
- 2) $RS < RT < TS$
- 3) $RT < RS < TS$
- 4) $RS < TS < RT$

88 What is an equation of the line that is perpendicular to the line whose equation is $y = \frac{3}{5}x - 2$ and that passes through the point $(3, -6)$?

- 1) $y = \frac{5}{3}x - 11$
- 2) $y = -\frac{5}{3}x + 11$
- 3) $y = -\frac{5}{3}x - 1$
- 4) $y = \frac{5}{3}x + 1$

89 Parallelogram $ABCD$ has coordinates $A(1, 5)$, $B(6, 3)$, $C(3, -1)$, and $D(-2, 1)$. What are the coordinates of E , the intersection of diagonals \overline{AC} and \overline{BD} ?

- 1) $(2, 2)$
- 2) $(4.5, 1)$
- 3) $(3.5, 2)$
- 4) $(-1, 3)$

90 When a quadrilateral is reflected over the line $y = x$, which geometric relationship is *not* preserved?

- 1) congruence
- 2) orientation
- 3) parallelism
- 4) perpendicularity

91 The equation of line k is $y = \frac{1}{3}x - 2$. The equation of line m is $-2x + 6y = 18$. Lines k and m are

- 1) parallel
- 2) perpendicular
- 3) the same line
- 4) neither parallel nor perpendicular

92 In the diagram of $\triangle ABC$ shown below, D is the midpoint of \overline{AB} , E is the midpoint of \overline{BC} , and F is the midpoint of \overline{AC} .

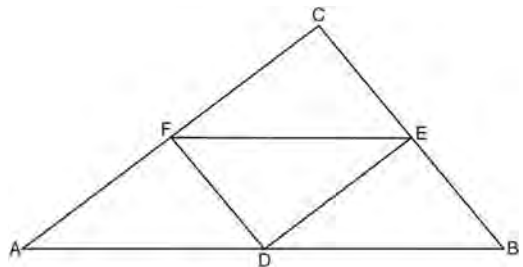

If $AB = 20$, $BC = 12$, and $AC = 16$, what is the perimeter of trapezoid $ABEF$?

- 1) 24
- 2) 36
- 3) 40
- 4) 44

93 A circle has the equation $(x - 2)^2 + (y + 3)^2 = 36$. What are the coordinates of its center and the length of its radius?

- 1) $(-2, 3)$ and 6
- 2) $(2, -3)$ and 6
- 3) $(-2, 3)$ and 36
- 4) $(2, -3)$ and 36

- 94 In the diagram below of $\triangle PAO$, \overline{AP} is tangent to circle O at point A , $OB = 7$, and $BP = 18$.

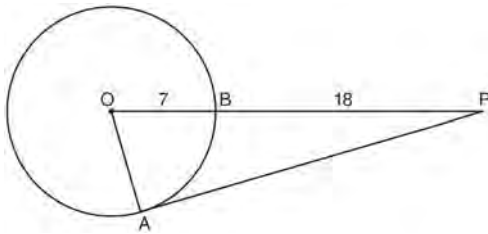

What is the length of \overline{AP} ?

- 1) 10
 - 2) 12
 - 3) 17
 - 4) 24
- 95 As shown in the diagram below, \overleftrightarrow{EF} intersects planes \mathcal{P} , Q , and \mathcal{R} .

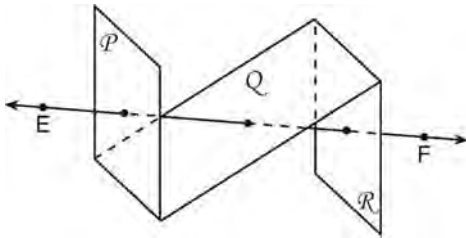

If \overleftrightarrow{EF} is perpendicular to planes \mathcal{P} and \mathcal{R} which statement must be true?

- 1) Plane \mathcal{P} is perpendicular to plane Q .
- 2) Plane \mathcal{R} is perpendicular to plane \mathcal{P} .
- 3) Plane \mathcal{P} is parallel to plane Q .
- 4) Plane \mathcal{R} is parallel to plane \mathcal{P} .

- 96 Which line is parallel to the line whose equation is $4x + 3y = 7$ and also passes through the point $(-5, 2)$?

- 1) $4x + 3y = -26$
- 2) $4x + 3y = -14$
- 3) $3x + 4y = -7$
- 4) $3x + 4y = 14$

- 97 Pentagon $PQRST$ has \overline{PQ} parallel to \overline{TS} . After a translation of $T_{2,-5}$, which line segment is parallel to $\overline{P'Q'}$?

- 1) $\overline{R'Q'}$
- 2) $\overline{R'S'}$
- 3) $\overline{T'S'}$
- 4) $\overline{T'P'}$

- 98 In the diagram below, $\triangle LMO$ is isosceles with $LO = MO$.

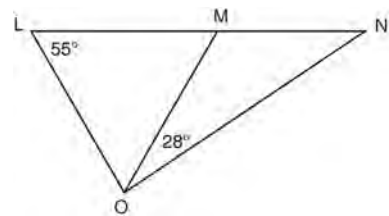

If $m\angle L = 55$ and $m\angle NOM = 28$, what is $m\angle N$?

- 1) 27
- 2) 28
- 3) 42
- 4) 70

Geometry Multiple Choice Regents Exam Questions

www.jmap.org

- 99 The statement " x is a multiple of 3, and x is an even integer" is true when x is equal to
- 1) 9
 - 2) 8
 - 3) 3
 - 4) 6

- 100 In the diagram below of circle O , chords \overline{AB} and \overline{CD} intersect at E .

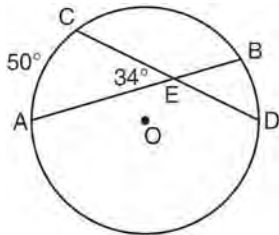

If $m\angle AEC = 34$ and $m\widehat{AC} = 50$, what is $m\widehat{DB}$?

- 1) 16
 - 2) 18
 - 3) 68
 - 4) 118
- 101 What is the volume, in cubic centimeters, of a cylinder that has a height of 15 cm and a diameter of 12 cm?
- 1) 180π
 - 2) 540π
 - 3) 675π
 - 4) $2,160\pi$
- 102 The volume of a rectangular prism is 144 cubic inches. The height of the prism is 8 inches. Which measurements, in inches, could be the dimensions of the base?
- 1) 3.3 by 5.5
 - 2) 2.5 by 7.2
 - 3) 12 by 8
 - 4) 9 by 9
- 103 When writing a geometric proof, which angle relationship could be used alone to justify that two angles are congruent?
- 1) supplementary angles
 - 2) linear pair of angles
 - 3) adjacent angles
 - 4) vertical angles
- 104 Which statement is the negation of "Two is a prime number" and what is the truth value of the negation?
- 1) Two is not a prime number; false
 - 2) Two is not a prime number; true
 - 3) A prime number is two; false
 - 4) A prime number is two; true
- 105 What is the length of the line segment whose endpoints are $(1, -4)$ and $(9, 2)$?
- 1) 5
 - 2) $2\sqrt{17}$
 - 3) 10
 - 4) $2\sqrt{26}$

Geometry Multiple Choice Regents Exam Questions

www.jmap.org

- 106 In the diagram below of isosceles trapezoid $ABCD$, $AB = CD = 25$, $AD = 26$, and $BC = 12$.

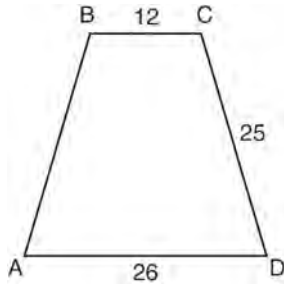

What is the length of an altitude of the trapezoid?

- 1) 7
 - 2) 14
 - 3) 19
 - 4) 24
- 107 A packing carton in the shape of a triangular prism is shown in the diagram below.

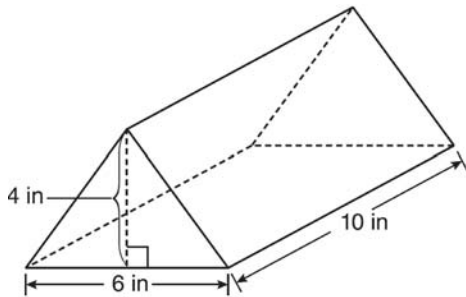

What is the volume, in cubic inches, of this carton?

- 1) 20
 - 2) 60
 - 3) 120
 - 4) 240
- 108 Which quadrilateral has diagonals that always bisect its angles and also bisect each other?
- 1) rhombus
 - 2) rectangle
 - 3) parallelogram
 - 4) isosceles trapezoid
- 109 Which equation represents the circle whose center is $(-5, 3)$ and that passes through the point $(-1, 3)$?
- 1) $(x + 1)^2 + (y - 3)^2 = 16$
 - 2) $(x - 1)^2 + (y + 3)^2 = 16$
 - 3) $(x + 5)^2 + (y - 3)^2 = 16$
 - 4) $(x - 5)^2 + (y + 3)^2 = 16$
- 110 Which equation represents circle O with center $(2, -8)$ and radius 9?
- 1) $(x + 2)^2 + (y - 8)^2 = 9$
 - 2) $(x - 2)^2 + (y + 8)^2 = 9$
 - 3) $(x + 2)^2 + (y - 8)^2 = 81$
 - 4) $(x - 2)^2 + (y + 8)^2 = 81$
- 111 Plane \mathcal{R} is perpendicular to line k and plane \mathcal{D} is perpendicular to line k . Which statement is correct?
- 1) Plane \mathcal{R} is perpendicular to plane \mathcal{D} .
 - 2) Plane \mathcal{R} is parallel to plane \mathcal{D} .
 - 3) Plane \mathcal{R} intersects plane \mathcal{D} .
 - 4) Plane \mathcal{R} bisects plane \mathcal{D} .

- 112 In the diagram of $\triangle KLM$ below, $m\angle L = 70$, $m\angle M = 50$, and \overline{MK} is extended through N .

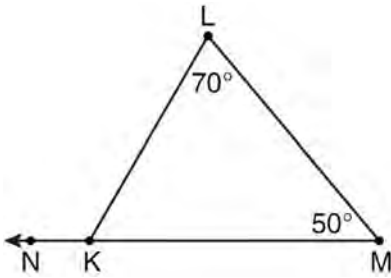

What is the measure of $\angle LKN$?

- 1) 60°
 - 2) 120°
 - 3) 180°
 - 4) 300°
- 113 The diagram below shows a rectangular prism.

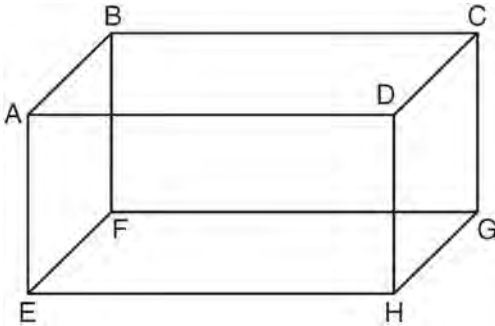

Which pair of edges are segments of lines that are coplanar?

- 114 What is an equation of the circle shown in the graph below?

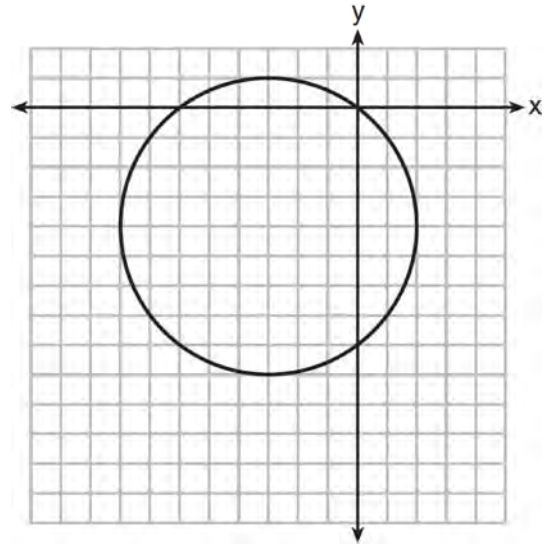

- 1) $(x - 3)^2 + (y - 4)^2 = 25$
 - 2) $(x + 3)^2 + (y + 4)^2 = 25$
 - 3) $(x - 3)^2 + (y - 4)^2 = 10$
 - 4) $(x + 3)^2 + (y + 4)^2 = 10$
- 115 The coordinates of the endpoints of \overline{AB} are $A(0, 0)$ and $B(0, 6)$. The equation of the perpendicular bisector of \overline{AB} is

- 1) \overline{AB} and \overline{DH}
 - 2) \overline{AE} and \overline{DC}
 - 3) \overline{BC} and \overline{EH}
 - 4) \overline{CG} and \overline{EF}
- 1) $x = 0$
 - 2) $x = 3$
 - 3) $y = 0$
 - 4) $y = 3$

- 116 What are the center and the radius of the circle whose equation is $(x - 5)^2 + (y + 3)^2 = 16$?
- 1) $(-5, 3)$ and 16
 - 2) $(5, -3)$ and 16
 - 3) $(-5, 3)$ and 4
 - 4) $(5, -3)$ and 4

- 117 Triangle ABC is graphed on the set of axes below.

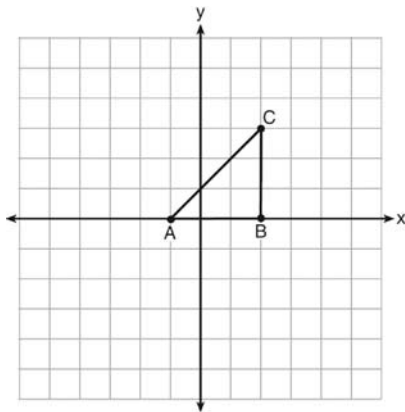

Which transformation produces an image that is similar to, but *not* congruent to, $\triangle ABC$?

- 1) $T_{2,3}$
 - 2) D_2
 - 3) $r_{y=x}$
 - 4) R_{90}
- 118 What is an equation of the circle with a radius of 5 and center at $(1, -4)$?
- 1) $(x + 1)^2 + (y - 4)^2 = 5$
 - 2) $(x - 1)^2 + (y + 4)^2 = 5$
 - 3) $(x + 1)^2 + (y - 4)^2 = 25$
 - 4) $(x - 1)^2 + (y + 4)^2 = 25$

- 119 In the diagram below of $\triangle ACE$, medians \overline{AD} , \overline{EB} , and \overline{CF} intersect at G . The length of \overline{FG} is 12 cm.

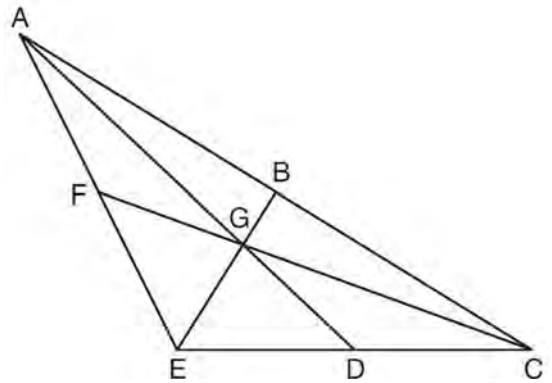

What is the length, in centimeters, of \overline{GC} ?

- 1) 24
 - 2) 12
 - 3) 6
 - 4) 4
- 120 As shown in the diagram of $\triangle ACD$ below, B is a point on \overline{AC} and \overline{DB} is drawn.

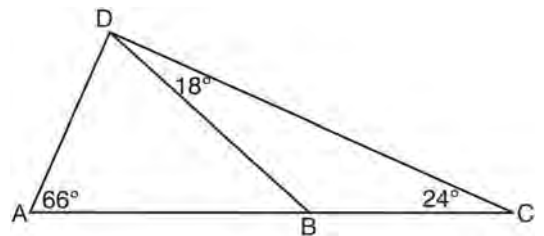

If $m\angle A = 66$, $m\angle CDB = 18$, and $m\angle C = 24$, what is the longest side of $\triangle ABD$?

- 1) \overline{AB}
- 2) \overline{DC}
- 3) \overline{AD}
- 4) \overline{BD}

- 121 In the diagram below of $\triangle BCD$, side \overline{DB} is extended to point A .

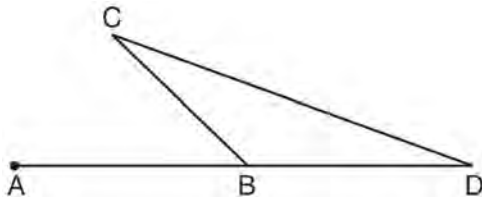

Which statement must be true?

- 1) $m\angle C > m\angle D$
 - 2) $m\angle ABC < m\angle D$
 - 3) $m\angle ABC > m\angle C$
 - 4) $m\angle ABC > m\angle C + m\angle D$
- 122 Segment AB is the diameter of circle M . The coordinates of A are $(-4, 3)$. The coordinates of M are $(1, 5)$. What are the coordinates of B ?
- 1) $(6, 7)$
 - 2) $(5, 8)$
 - 3) $(-3, 8)$
 - 4) $(-5, 2)$

- 123 Scalene triangle ABC is similar to triangle DEF . Which statement is *false*?
- 1) $AB:BC=DE:EF$
 - 2) $AC:DF=BC:EF$
 - 3) $\angle ACB \cong \angle DFE$
 - 4) $\angle ABC \cong \angle EDF$

- 124 The angles of triangle ABC are in the ratio of $8:3:4$. What is the measure of the *smallest* angle?
- 1) 12°
 - 2) 24°
 - 3) 36°
 - 4) 72°

- 125 As shown in the diagram below, \overline{AC} bisects $\angle BAD$ and $\angle B \cong \angle D$.

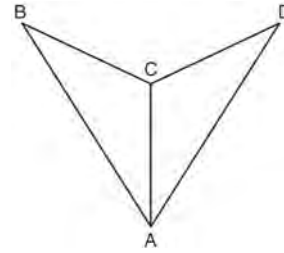

Which method could be used to prove $\triangle ABC \cong \triangle ADC$?

- 1) SSS
 - 2) AAA
 - 3) SAS
 - 4) AAS
- 126 In the diagram below, $\triangle ABC \cong \triangle XYZ$.

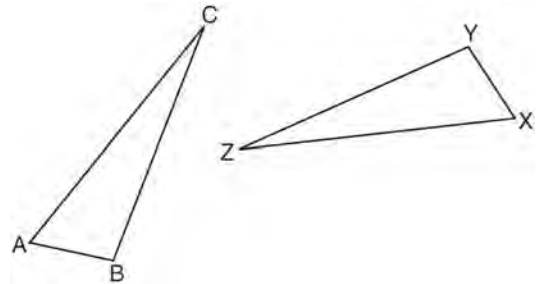

Which statement must be true?

- 1) $\angle C \cong \angle Y$
- 2) $\angle A \cong \angle X$
- 3) $\overline{AC} \cong \overline{YZ}$
- 4) $\overline{CB} \cong \overline{XZ}$

- 127 In the diagram below of $\triangle ABC$, $\overline{AE} \cong \overline{BE}$, $\overline{AF} \cong \overline{CF}$, and $\overline{CD} \cong \overline{BD}$.

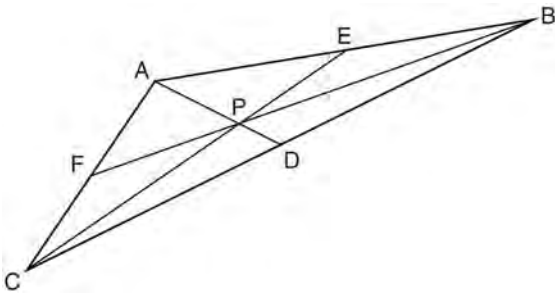

Point P must be the

- 1) centroid
 - 2) circumcenter
 - 3) Incenter
 - 4) orthocenter
- 128 Which reason could be used to prove that a parallelogram is a rhombus?
- 1) Diagonals are congruent.
 - 2) Opposite sides are parallel.
 - 3) Diagonals are perpendicular.
 - 4) Opposite angles are congruent.
- 129 What is the equation of the line that passes through the point $(-9, 6)$ and is perpendicular to the line $y = 3x - 5$?
- 1) $y = 3x + 21$
 - 2) $y = -\frac{1}{3}x - 3$
 - 3) $y = 3x + 33$
 - 4) $y = -\frac{1}{3}x + 3$

- 130 The point $(3, -2)$ is rotated 90° about the origin and then dilated by a scale factor of 4. What are the coordinates of the resulting image?
- 1) $(-12, 8)$
 - 2) $(12, -8)$
 - 3) $(8, 12)$
 - 4) $(-8, -12)$

- 131 What is an equation of circle O shown in the graph below?

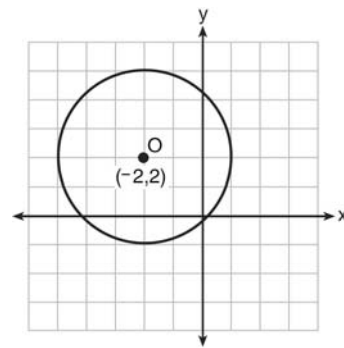

- 1) $(x + 2)^2 + (y - 2)^2 = 9$
 - 2) $(x + 2)^2 + (y - 2)^2 = 3$
 - 3) $(x - 2)^2 + (y + 2)^2 = 9$
 - 4) $(x - 2)^2 + (y + 2)^2 = 3$
- 132 What is an equation of a circle with center $(7, -3)$ and radius 4?
- 1) $(x - 7)^2 + (y + 3)^2 = 4$
 - 2) $(x + 7)^2 + (y - 3)^2 = 4$
 - 3) $(x - 7)^2 + (y + 3)^2 = 16$
 - 4) $(x + 7)^2 + (y - 3)^2 = 16$

- 133 In parallelogram $ABCD$ shown below, diagonals AC and BD intersect at E .

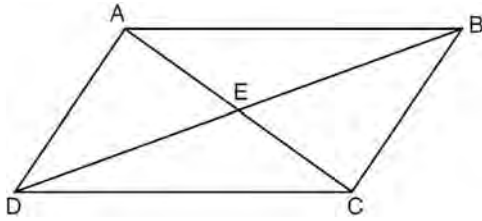

Which statement must be true?

- 1) $\overline{AC} \cong \overline{DB}$
 - 2) $\angle ABD \cong \angle CBD$
 - 3) $\triangle AED \cong \triangle CEB$
 - 4) $\triangle DCE \cong \triangle BCE$
- 134 In the diagram below of circle O , \overline{PA} is tangent to circle O at A , and \overline{PBC} is a secant with points B and C on the circle.

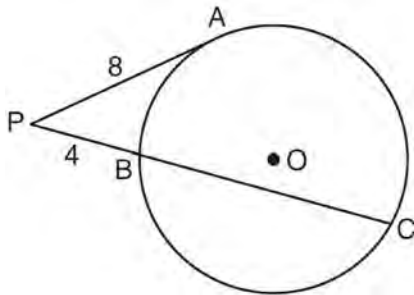

If $PA = 8$ and $PB = 4$, what is the length of \overline{BC} ?

- 1) 20
- 2) 16
- 3) 15
- 4) 12

- 135 In the diagram below, $\triangle ABC$ is circumscribed about circle O and the sides of $\triangle ABC$ are tangent to the circle at points D , E , and F .

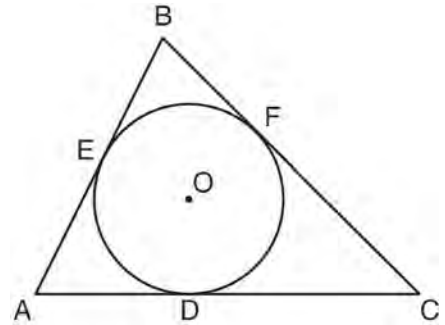

If $AB = 20$, $AE = 12$, and $CF = 15$, what is the length of AC ?

- 1) 8
- 2) 15
- 3) 23
- 4) 27

- 136 As shown in the diagram below, $\triangle ABC \sim \triangle DEF$, $AB = 7x$, $BC = 4$, $DE = 7$, and $EF = x$.

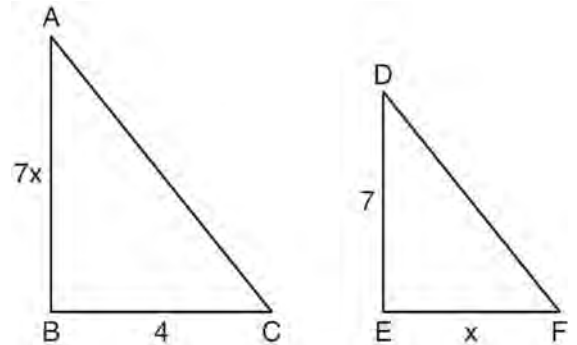

What is the length of \overline{AB} ?

- 1) 28
- 2) 2
- 3) 14
- 4) 4

137 Which diagram represents a correct construction of equilateral $\triangle ABC$, given side \overline{AB} ?

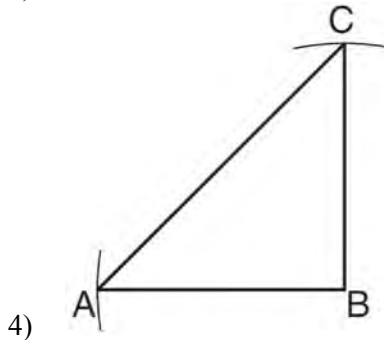
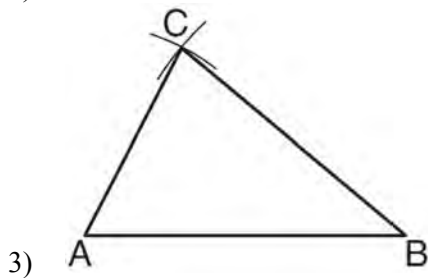
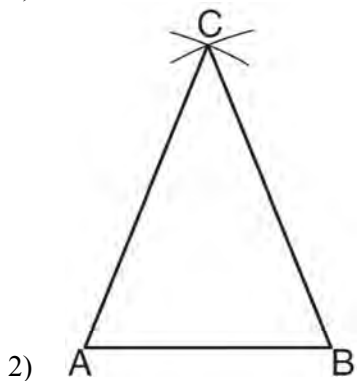
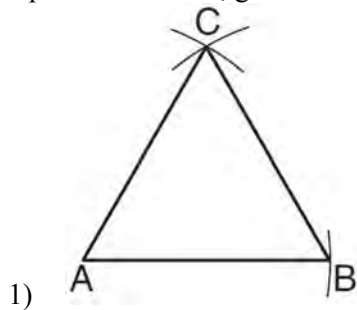

138 As shown in the diagram below of $\triangle ABC$, a compass is used to find points D and E , equidistant from point A . Next, the compass is used to find point F , equidistant from points D and E . Finally, a straightedge is used to draw \overrightarrow{AF} . Then, point G , the intersection of \overrightarrow{AF} and side \overline{BC} of $\triangle ABC$, is labeled.

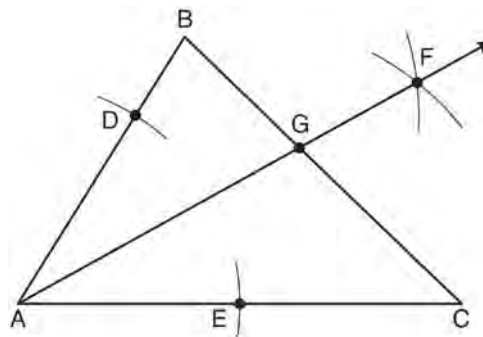

Which statement must be true?

- 1) \overrightarrow{AF} bisects side \overline{BC}
- 2) \overrightarrow{AF} bisects $\angle BAC$
- 3) $\overrightarrow{AF} \perp \overline{BC}$
- 4) $\triangle ABG \sim \triangle ACG$

139 Lines m and n intersect at point A . Line k is perpendicular to both lines m and n at point A . Which statement *must* be true?

- 1) Lines m , n , and k are in the same plane.
- 2) Lines m and n are in two different planes.
- 3) Lines m and n are perpendicular to each other.
- 4) Line k is perpendicular to the plane containing lines m and n .

- 140 In the diagram below, $MATH$ is a rhombus with diagonals AH and MT .

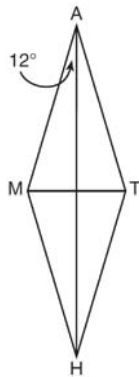

If $m\angle HAM = 12$, what is $m\angle AMT$?

- 1) 12
 - 2) 78
 - 3) 84
 - 4) 156
- 141 Point P lies on line m . Point P is also included in distinct planes Q , R , S , and T . At most, how many of these planes could be perpendicular to line m ?
- 1) 1
 - 2) 2
 - 3) 3
 - 4) 4
- 142 Which compound statement is true?
- 1) A triangle has three sides and a quadrilateral has five sides.
 - 2) A triangle has three sides if and only if a quadrilateral has five sides.
 - 3) If a triangle has three sides, then a quadrilateral has five sides.
 - 4) A triangle has three sides or a quadrilateral has five sides.

- 143 Given that $ABCD$ is a parallelogram, a student wrote the proof below to show that a pair of its opposite angles are congruent.

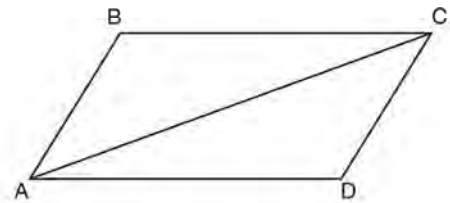

Statement	Reason
1. $ABCD$ is a parallelogram.	1. Given
2. $\overline{BC} \cong \overline{AD}$ $\overline{AB} \cong \overline{DC}$	2. Opposite sides of a parallelogram are congruent.
3. $\overline{AC} \cong \overline{CA}$	3. Reflexive Postulate of Congruency
4. $\triangle ABC \cong \triangle CDA$	4. Side-Side-Side
5. $\angle B \cong \angle D$	5. _____

What is the reason justifying that $\angle B \cong \angle D$?

- 1) Opposite angles in a quadrilateral are congruent.
 - 2) Parallel lines have congruent corresponding angles.
 - 3) Corresponding parts of congruent triangles are congruent.
 - 4) Alternate interior angles in congruent triangles are congruent.
- 144 An equation of the line that passes through $(2, -1)$ and is parallel to the line $2y + 3x = 8$ is
- 1) $y = \frac{3}{2}x - 4$
 - 2) $y = \frac{3}{2}x + 4$
 - 3) $y = -\frac{3}{2}x - 2$
 - 4) $y = -\frac{3}{2}x + 2$

Geometry Multiple Choice Regents Exam Questions

www.jmap.org

- 145 In the diagram below of rhombus $ABCD$, $m\angle C = 100$.

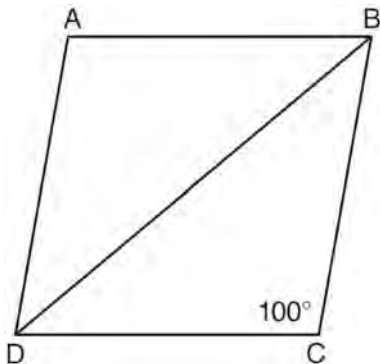

What is $m\angle DBC$?

- 1) 40
 - 2) 45
 - 3) 50
 - 4) 80
- 146 As shown in the diagram below, lines m and n are cut by transversal p .

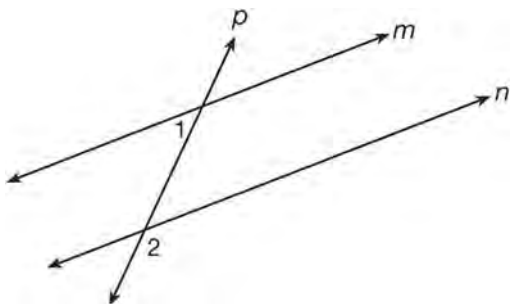

If $m\angle 1 = 4x + 14$ and $m\angle 2 = 8x + 10$, lines m and n are parallel when x equals

- 1) 1
- 2) 6
- 3) 13
- 4) 17

- 147 Lines a and b intersect at point P . Line c passes through P and is perpendicular to the plane containing lines a and b . Which statement must be true?

- 1) Lines a , b , and c are coplanar.
- 2) Line a is perpendicular to line b .
- 3) Line c is perpendicular to both line a and line b .
- 4) Line c is perpendicular to line a or line b , but not both.

- 148 As shown in the diagram below, a kite needs a vertical and a horizontal support bar attached at opposite corners. The upper edges of the kite are 7 inches, the side edges are x inches, and the vertical support bar is $(x + 1)$ inches.

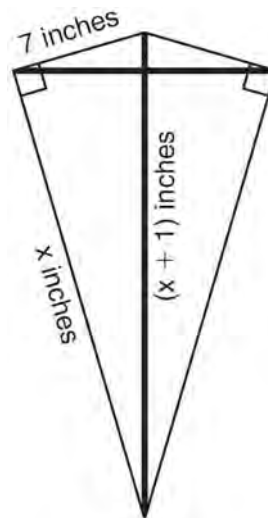

What is the measure, in inches, of the vertical support bar?

- 1) 23
- 2) 24
- 3) 25
- 4) 26

- 149 Which graph represents a circle with the equation $(x - 3)^2 + (y + 1)^2 = 4$?

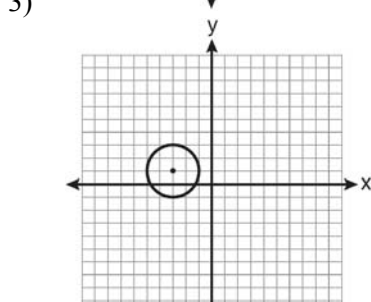
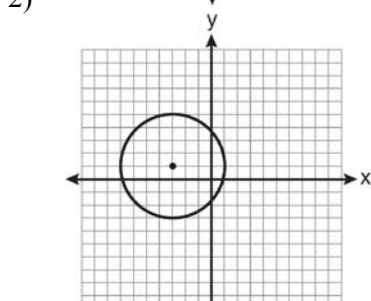
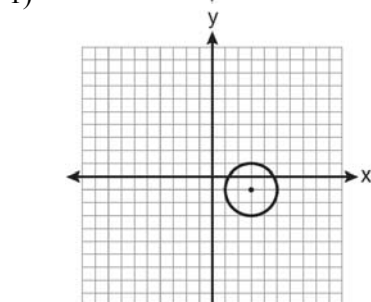
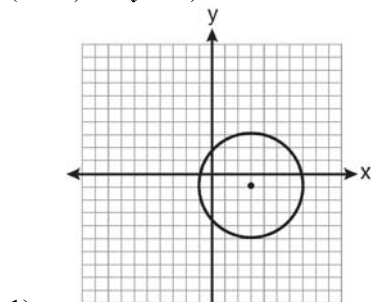

- 150 The number of degrees in the sum of the interior angles of a pentagon is

- 1) 72
- 2) 360
- 3) 540
- 4) 720

- 151 Which equation represents the perpendicular bisector of \overline{AB} whose endpoints are $A(8, 2)$ and $B(0, 6)$?

- 1) $y = 2x - 4$
- 2) $y = -\frac{1}{2}x + 2$
- 3) $y = -\frac{1}{2}x + 6$
- 4) $y = 2x - 12$

- 152 Which equation of a circle will have a graph that lies entirely in the first quadrant?

- 1) $(x - 4)^2 + (y - 5)^2 = 9$
- 2) $(x + 4)^2 + (y + 5)^2 = 9$
- 3) $(x + 4)^2 + (y + 5)^2 = 25$
- 4) $(x - 5)^2 + (y - 4)^2 = 25$

- 153 The volume, in cubic centimeters, of a sphere whose diameter is 6 centimeters is

- 1) 12π
- 2) 36π
- 3) 48π
- 4) 288π

- 154 As shown on the graph below, $\triangle R'S'T'$ is the image of $\triangle RST$ under a single transformation.

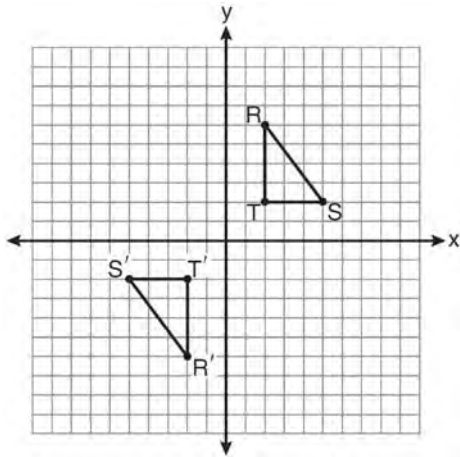

Which transformation does this graph represent?

- 1) glide reflection
 - 2) line reflection
 - 3) rotation
 - 4) translation
- 155 What is an equation of the line that passes through the point $(-2, 3)$ and is parallel to the line whose equation is $y = \frac{3}{2}x - 4$?

- 1) $y = \frac{-2}{3}x$
- 2) $y = \frac{-2}{3}x + \frac{5}{3}$
- 3) $y = \frac{3}{2}x$
- 4) $y = \frac{3}{2}x + 6$

- 156 When solved graphically, what is the solution to the following system of equations?

$$y = x^2 - 4x + 6$$

$$y = x + 2$$

- 1) $(1, 4)$
 - 2) $(4, 6)$
 - 3) $(1, 3)$ and $(4, 6)$
 - 4) $(3, 1)$ and $(6, 4)$
- 157 Line segment AB is shown in the diagram below.

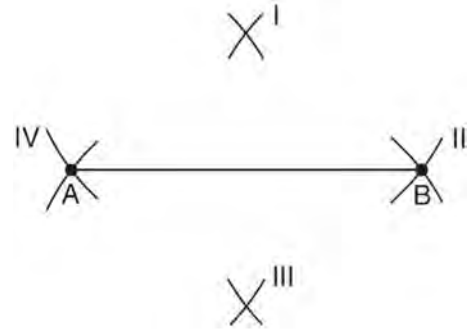

Which two sets of construction marks, labeled I, II, III, and IV, are part of the construction of the perpendicular bisector of line segment AB ?

- 1) I and II
 - 2) I and III
 - 3) II and III
 - 4) II and IV
- 158 If the vertex angles of two isosceles triangles are congruent, then the triangles must be
- 1) acute
 - 2) congruent
 - 3) right
 - 4) similar

- 159 In $\triangle PQR$, $\angle PRQ$ is a right angle and \overline{RT} is drawn perpendicular to hypotenuse \overline{PQ} . If $PT = x$, $RT = 6$, and $TQ = 4x$, what is the length of \overline{PQ} ?
- 1) 9
 - 2) 12
 - 3) 3
 - 4) 15

- 160 A student wrote the sentence “4 is an odd integer.” What is the negation of this sentence and the truth value of the negation?
- 1) 3 is an odd integer; true
 - 2) 4 is not an odd integer; true
 - 3) 4 is not an even integer; false
 - 4) 4 is an even integer; false

- 161 Line n intersects lines l and m , forming the angles shown in the diagram below.

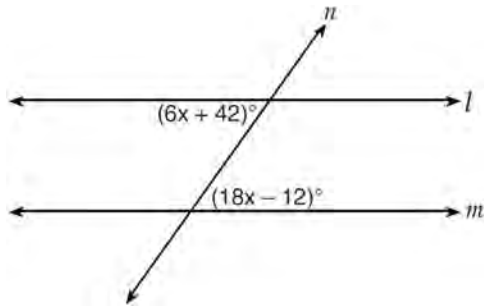

Which value of x would prove $l \parallel m$?

- 1) 2.5
- 2) 4.5
- 3) 6.25
- 4) 8.75

- 162 In the diagram below, lines n and m are cut by transversals p and q .

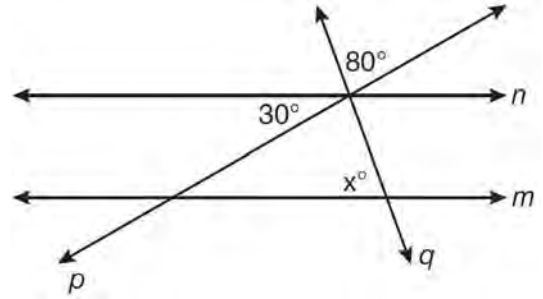

What value of x would make lines n and m parallel?

- 1) 110
- 2) 80
- 3) 70
- 4) 50

- 163 In the diagram below, parallelogram $ABCD$ has diagonals \overline{AC} and \overline{BD} that intersect at point E .

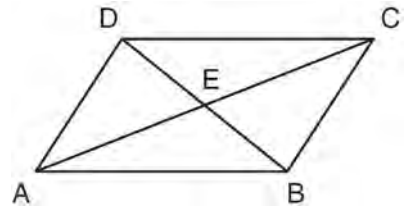

Which expression is *not* always true?

- 1) $\angle DAE \cong \angle BCE$
- 2) $\angle DEC \cong \angle BEA$
- 3) $\overline{AC} \cong \overline{DB}$
- 4) $\overline{DE} \cong \overline{EB}$

- 164 In the diagram below of right triangle ABC , \overline{CD} is the altitude to hypotenuse AB , $CB = 6$, and $AD = 5$.

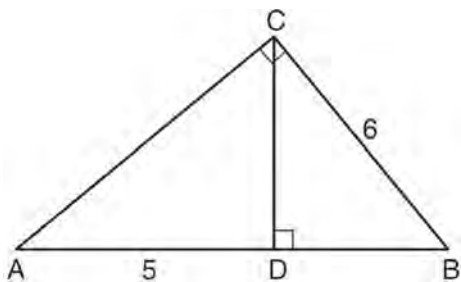

What is the length of \overline{BD} ?

- 1) 5
 - 2) 9
 - 3) 3
 - 4) 4
- 165 Point A lies in plane \mathcal{B} . How many lines can be drawn perpendicular to plane \mathcal{B} through point A ?
- 1) one
 - 2) two
 - 3) zero
 - 4) infinite

- 166 Quadrilateral $MNOP$ is a trapezoid with $\overline{MN} \parallel \overline{OP}$. If $M'N'O'P'$ is the image of $MNOP$ after a reflection over the x -axis, which two sides of quadrilateral $M'N'O'P'$ are parallel?

- 1) $\overline{M'N'}$ and $\overline{O'P'}$
- 2) $\overline{M'N'}$ and $\overline{N'O'}$
- 3) $\overline{P'M'}$ and $\overline{O'P'}$
- 4) $\overline{P'M'}$ and $\overline{N'O'}$

- 167 A straightedge and compass were used to create the construction below. Arc EF was drawn from point B , and arcs with equal radii were drawn from E and F .

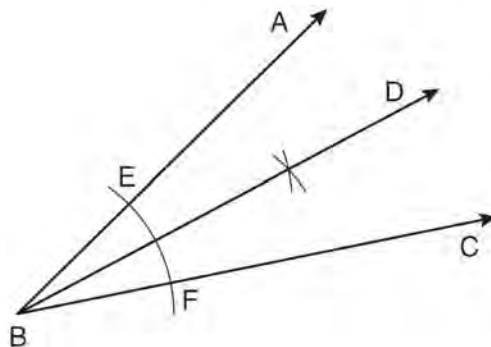

Which statement is *false*?

- 1) $m\angle ABD = m\angle DBC$
 - 2) $\frac{1}{2}(m\angle ABC) = m\angle ABD$
 - 3) $2(m\angle DBC) = m\angle ABC$
 - 4) $2(m\angle ABC) = m\angle CBD$
- 168 In the diagram below, \overline{DE} joins the midpoints of two sides of $\triangle ABC$.

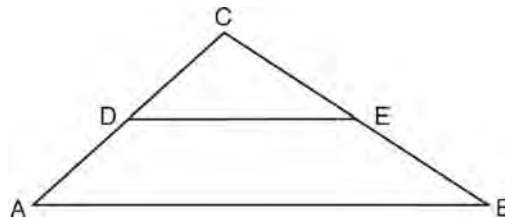

Which statement is *not* true?

- 1) $CE = \frac{1}{2} CB$
- 2) $DE = \frac{1}{2} AB$
- 3) area of $\triangle CDE = \frac{1}{2}$ area of $\triangle CAB$
- 4) perimeter of $\triangle CDE = \frac{1}{2}$ perimeter of $\triangle CAB$

- 169 In rhombus $ABCD$, the diagonals \overline{AC} and \overline{BD} intersect at E . If $AE = 5$ and $BE = 12$, what is the length of \overline{AB} ?
- 1) 7
 - 2) 10
 - 3) 13
 - 4) 17

- 170 In the diagram below of \overline{ABCD} , $\overline{AC} \cong \overline{BD}$.



Using this information, it could be proven that

- 1) $BC = AB$
 - 2) $AB = CD$
 - 3) $AD - BC = CD$
 - 4) $AB + CD = AD$
- 171 In the diagram below of circle O , diameter \overline{AOB} is perpendicular to chord \overline{CD} at point E , $OA = 6$, and $OE = 2$.

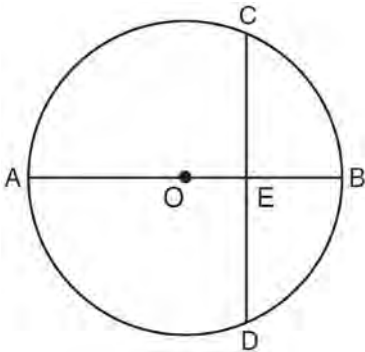

What is the length of \overline{CE} ?

- 1) $4\sqrt{3}$
- 2) $2\sqrt{3}$
- 3) $8\sqrt{2}$
- 4) $4\sqrt{2}$

- 172 What is the slope of a line that is perpendicular to the line whose equation is $3x + 5y = 4$?

- 1) $-\frac{3}{5}$
- 2) $\frac{3}{5}$
- 3) $-\frac{5}{3}$
- 4) $\frac{5}{3}$

- 173 What is an equation of circle O shown in the graph below?

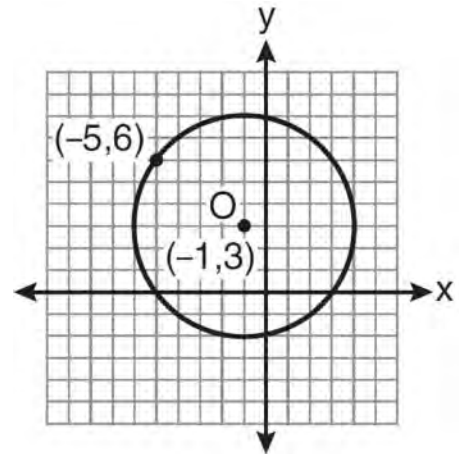

- 1) $(x + 1)^2 + (y - 3)^2 = 25$
- 2) $(x - 1)^2 + (y + 3)^2 = 25$
- 3) $(x - 5)^2 + (y + 6)^2 = 25$
- 4) $(x + 5)^2 + (y - 6)^2 = 25$

- 174 How many points are both 4 units from the origin and also 2 units from the line $y = 4$?

- 1) 1
- 2) 2
- 3) 3
- 4) 4

- 175 In the diagram below, \overline{AB} , \overline{BC} , and \overline{AC} are tangents to circle O at points F , E , and D , respectively, $AF = 6$, $CD = 5$, and $BE = 4$.

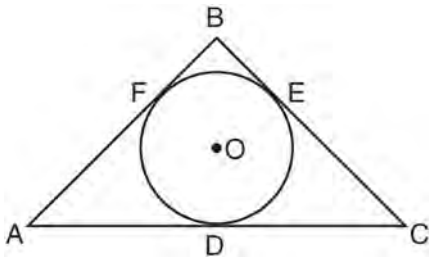

What is the perimeter of $\triangle ABC$?

- 1) 15
 - 2) 25
 - 3) 30
 - 4) 60
- 176 In the diagram below of $\triangle ABC$, $\overleftrightarrow{TV} \parallel \overline{BC}$, $AT = 5$, $TB = 7$, and $AV = 10$.

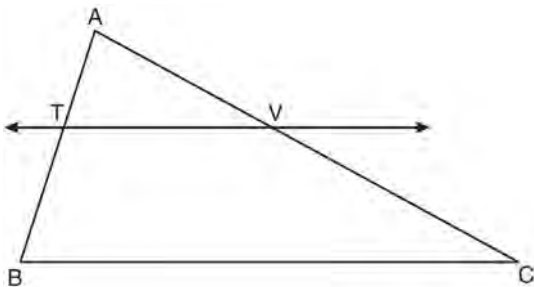

What is the length of \overline{VC} ?

- 177 The diagram below shows a pair of congruent triangles, with $\angle ADB \cong \angle CDB$ and $\angle ABD \cong \angle CBD$.

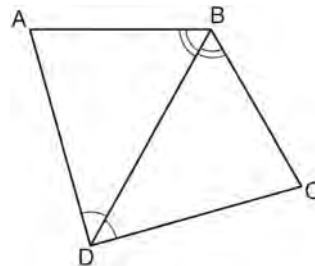

Which statement must be true?

- 1) $\angle ADB \cong \angle CBD$
 - 2) $\angle ABC \cong \angle ADC$
 - 3) $\overline{AB} \cong \overline{CD}$
 - 4) $\overline{AD} \cong \overline{CD}$
- 178 A line segment has endpoints $(4, 7)$ and $(1, 11)$. What is the length of the segment?
- 1) 5
 - 2) 7
 - 3) 16
 - 4) 25

- 179 Point M is the midpoint of \overline{AB} . If the coordinates of A are $(-3, 6)$ and the coordinates of M are $(-5, 2)$, what are the coordinates of B ?
- 1) $(1, 2)$
 - 2) $(7, 10)$
 - 3) $(-4, 4)$
 - 4) $(-7, -2)$

- 180 In $\triangle ABC$ and $\triangle DEF$, $\frac{AC}{DF} = \frac{CB}{FE}$. Which additional information would prove $\triangle ABC \sim \triangle DEF$?
- 1) $AC = DF$
 - 2) $CB = FE$
 - 3) $\angle ACB \cong \angle DFE$
 - 4) $\angle BAC \cong \angle EDF$

- 181 If \overleftrightarrow{AB} is contained in plane \mathcal{P} , and \overleftrightarrow{AB} is perpendicular to plane \mathcal{R} , which statement is true?
- 1) \overleftrightarrow{AB} is parallel to plane \mathcal{R} .
 - 2) Plane \mathcal{P} is parallel to plane \mathcal{R} .
 - 3) \overleftrightarrow{AB} is perpendicular to plane \mathcal{P} .
 - 4) Plane \mathcal{P} is perpendicular to plane \mathcal{R} .

- 182 In circle O shown below, diameter \overline{DB} is perpendicular to chord \overline{AC} at E .

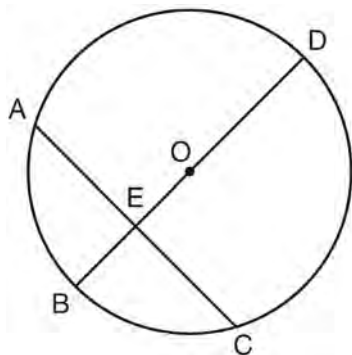

- If $DB = 34$, $AC = 30$, and $DE > BE$, what is the length of \overline{BE} ?
- 1) 8
 - 2) 9
 - 3) 16
 - 4) 25

- 183 A man wants to place a new bird bath in his yard so that it is 30 feet from a fence, f , and also 10 feet from a light pole, P . As shown in the diagram below, the light pole is 35 feet away from the fence.

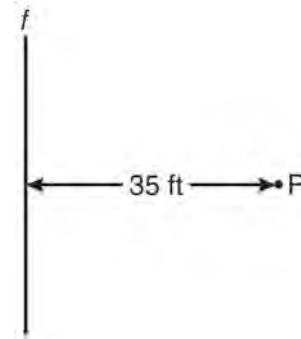

- How many locations are possible for the bird bath?
- 1) 1
 - 2) 2
 - 3) 3
 - 4) 0

- 184 For which polygon does the sum of the measures of the interior angles equal the sum of the measures of the exterior angles?
- 1) hexagon
 - 2) pentagon
 - 3) quadrilateral
 - 4) triangle

- 185 The diameter of a sphere is 15 inches. What is the volume of the sphere, to the nearest tenth of a cubic inch?
- 1) 706.9
 - 2) 1767.1
 - 3) 2827.4
 - 4) 14,137.2

Geometry Multiple Choice Regents Exam Questions

www.jmap.org

186 Which equation represents the line that is perpendicular to $2y = x + 2$ and passes through the point $(4, 3)$?

- 1) $y = \frac{1}{2}x - 5$
- 2) $y = \frac{1}{2}x + 1$
- 3) $y = -2x + 11$
- 4) $y = -2x - 5$

187 For a triangle, which two points of concurrence could be located outside the triangle?

- 1) incenter and centroid
- 2) centroid and orthocenter
- 3) incenter and circumcenter
- 4) circumcenter and orthocenter

188 In triangles ABC and DEF , $AB = 4$, $AC = 5$, $DE = 8$, $DF = 10$, and $\angle A \cong \angle D$. Which method could be used to prove $\triangle ABC \sim \triangle DEF$?

- 1) AA
- 2) SAS
- 3) SSS
- 4) ASA

189 The equation of a circle with its center at $(-3, 5)$ and a radius of 4 is

- 1) $(x + 3)^2 + (y - 5)^2 = 4$
- 2) $(x - 3)^2 + (y + 5)^2 = 4$
- 3) $(x + 3)^2 + (y - 5)^2 = 16$
- 4) $(x - 3)^2 + (y + 5)^2 = 16$

190 If two distinct planes, \mathcal{A} and \mathcal{B} , are perpendicular to line c , then which statement is true?

- 1) Planes \mathcal{A} and \mathcal{B} are parallel to each other.
- 2) Planes \mathcal{A} and \mathcal{B} are perpendicular to each other.
- 3) The intersection of planes \mathcal{A} and \mathcal{B} is a line parallel to line c .
- 4) The intersection of planes \mathcal{A} and \mathcal{B} is a line perpendicular to line c .

191 The vertices of parallelogram $ABCD$ are $A(2, 0)$, $B(0, -3)$, $C(3, -3)$, and $D(5, 0)$. If $ABCD$ is reflected over the x -axis, how many vertices remain invariant?

- 1) 1
- 2) 2
- 3) 3
- 4) 0

192 In the diagram below of $\triangle ABC$, $\overline{AB} \cong \overline{AC}$, $m\angle A = 3x$, and $m\angle B = x + 20$.

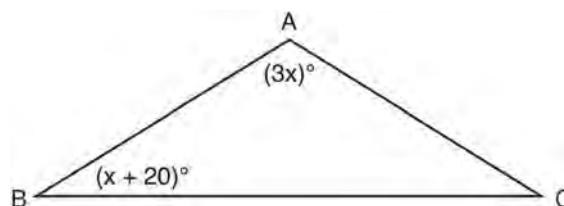

What is the value of x ?

- 1) 10
- 2) 28
- 3) 32
- 4) 40

- 193 The graph below shows \overline{JT} and its image, $\overline{J'T'}$, after a transformation.

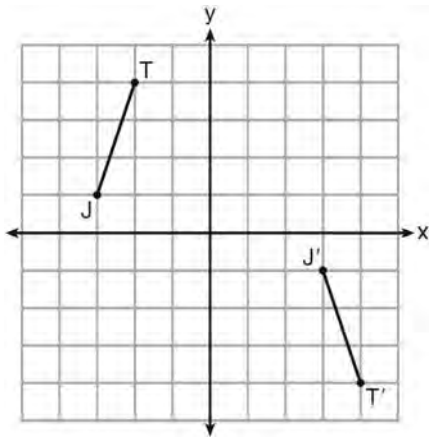

Which transformation would map \overline{JT} onto $\overline{J'T'}$?

- 1) translation
 - 2) glide reflection
 - 3) rotation centered at the origin
 - 4) reflection through the origin
- 194 Which equation represents a line that is parallel to the line whose equation is $y = \frac{3}{2}x - 3$ and passes through the point $(1, 2)$?

- 1) $y = \frac{3}{2}x + \frac{1}{2}$
- 2) $y = \frac{2}{3}x + \frac{4}{3}$
- 3) $y = \frac{3}{2}x - 2$
- 4) $y = -\frac{2}{3}x + \frac{8}{3}$

- 195 When a dilation is performed on a hexagon, which property of the hexagon will *not* be preserved in its image?
- 1) parallelism
 - 2) orientation
 - 3) length of sides
 - 4) measure of angles

- 196 What is the equation of a circle whose center is 4 units above the origin in the coordinate plane and whose radius is 6?

- 1) $x^2 + (y - 6)^2 = 16$
- 2) $(x - 6)^2 + y^2 = 16$
- 3) $x^2 + (y - 4)^2 = 36$
- 4) $(x - 4)^2 + y^2 = 36$

- 197 The diagram below represents a rectangular solid.

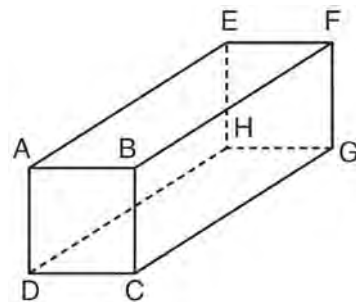

Which statement must be true?

- 1) \overline{EH} and \overline{BC} are coplanar
- 2) \overline{FG} and \overline{AB} are coplanar
- 3) \overline{EH} and \overline{AD} are skew
- 4) \overline{FG} and \overline{CG} are skew

Geometry Multiple Choice Regents Exam Questions

www.jmap.org

198 The sum of the interior angles of a polygon of n sides is

- 1) 360
- 2) $\frac{360}{n}$
- 3) $(n - 2) \cdot 180$
- 4) $\frac{(n - 2) \cdot 180}{n}$

199 Plane \mathcal{A} is parallel to plane \mathcal{B} . Plane \mathcal{C} intersects plane \mathcal{A} in line m and intersects plane \mathcal{B} in line n .

- Lines m and n are
- 1) intersecting
 - 2) parallel
 - 3) perpendicular
 - 4) skew

200 The coordinates of point A are $(-3a, 4b)$. If point A' is the image of point A reflected over the line $y = x$, the coordinates of A' are

- 1) $(4b, -3a)$
- 2) $(3a, 4b)$
- 3) $(-3a, -4b)$
- 4) $(-4b, -3a)$

201 The slope of line ℓ is $-\frac{1}{3}$. What is an equation of a line that is perpendicular to line ℓ ?

- 1) $y + 2 = \frac{1}{3}x$
- 2) $-2x + 6 = 6y$
- 3) $9x - 3y = 27$
- 4) $3x + y = 0$

202 In the diagram below of right triangle ABC , altitude \overline{BD} is drawn to hypotenuse \overline{AC} , $AC = 16$, and $CD = 7$.

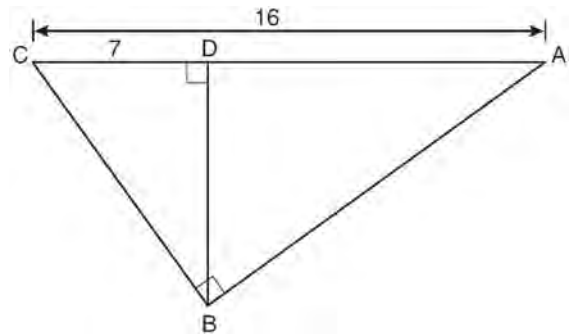

What is the length of \overline{BD} ?

- 1) $3\sqrt{7}$
- 2) $4\sqrt{7}$
- 3) $7\sqrt{3}$
- 4) 12

203 In the diagram below, line p intersects line m and line n .

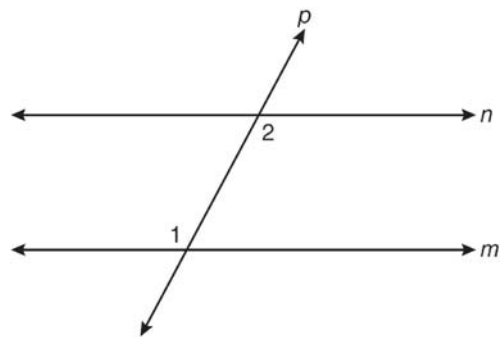

If $m\angle 1 = 7x$ and $m\angle 2 = 5x + 30$, lines m and n are parallel when x equals

- 1) 12.5
- 2) 15
- 3) 87.5
- 4) 105

Geometry Multiple Choice Regents Exam Questions

www.jmap.org

- 204 In the diagram below of $\triangle DAE$ and $\triangle BCE$, \overline{AB} and \overline{CD} intersect at E , such that $\overline{AE} \cong \overline{CE}$ and $\angle BCE \cong \angle DAE$.

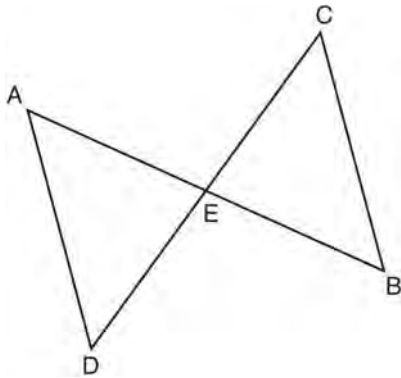

Triangle DAE can be proved congruent to triangle BCE by

- 1) ASA
 - 2) SAS
 - 3) SSS
 - 4) HL
- 205 Given three distinct quadrilaterals, a square, a rectangle, and a rhombus, which quadrilaterals must have perpendicular diagonals?
- 1) the rhombus, only
 - 2) the rectangle and the square
 - 3) the rhombus and the square
 - 4) the rectangle, the rhombus, and the square
- 206 The diagonals of a quadrilateral are congruent but do not bisect each other. This quadrilateral is
- 1) an isosceles trapezoid
 - 2) a parallelogram
 - 3) a rectangle
 - 4) a rhombus
- 207 Triangle PQR has angles in the ratio of 2:3:5. Which type of triangle is $\triangle PQR$?
- 1) acute
 - 2) isosceles
 - 3) obtuse
 - 4) right
- 208 In circle O , a diameter has endpoints $(-5, 4)$ and $(3, -6)$. What is the length of the diameter?
- 1) $\sqrt{2}$
 - 2) $2\sqrt{2}$
 - 3) $\sqrt{10}$
 - 4) $2\sqrt{41}$
- 209 A line segment has endpoints $A(7, -1)$ and $B(-3, 3)$. What are the coordinates of the midpoint of \overline{AB} ?
- 1) $(1, 2)$
 - 2) $(2, 1)$
 - 3) $(-5, 2)$
 - 4) $(5, -2)$
- 210 What is the slope of a line perpendicular to the line whose equation is $20x - 2y = 6$?
- 1) -10
 - 2) $-\frac{1}{10}$
 - 3) 10
 - 4) $\frac{1}{10}$

- 211 What is the image of the point $(2, -3)$ after the transformation $r_{y\text{-axis}}$?
- 1) $(2, 3)$
 - 2) $(-2, -3)$
 - 3) $(-2, 3)$
 - 4) $(-3, 2)$

- 212 As shown in the diagram below, \overline{FJ} is contained in plane \mathcal{R} , \overline{BC} and \overline{DE} are contained in plane \mathcal{S} , and \overline{FJ} , \overline{BC} , and \overline{DE} intersect at A .

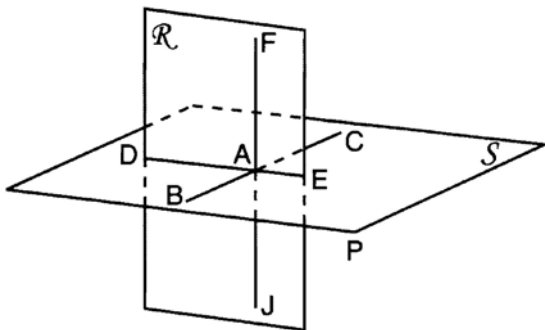

Which fact is *not* sufficient to show that planes \mathcal{R} and \mathcal{S} are perpendicular?

- 1) $\overline{FA} \perp \overline{DE}$
 - 2) $\overline{AD} \perp \overline{AF}$
 - 3) $\overline{BC} \perp \overline{FJ}$
 - 4) $\overline{DE} \perp \overline{BC}$
- 213 Line segment \overline{AB} is a diameter of circle O whose center has coordinates $(6, 8)$. What are the coordinates of point B if the coordinates of point A are $(4, 2)$?
- 1) $(1, 3)$
 - 2) $(5, 5)$
 - 3) $(8, 14)$
 - 4) $(10, 10)$

- 214 In $\triangle ABC$ shown below, P is the centroid and $BF = 18$.

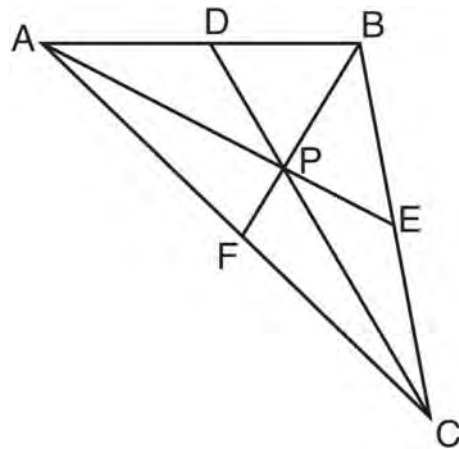

What is the length of \overline{BP} ?

- 1) 6
 - 2) 9
 - 3) 3
 - 4) 12
- 215 In the diagram below of circle O , diameter \overline{AB} is parallel to chord \overline{CD} .

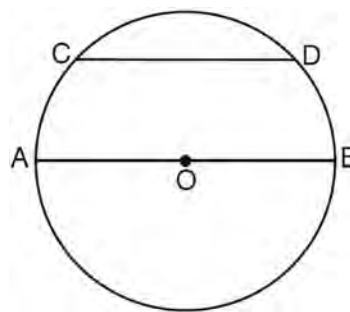

If $m\widehat{CD} = 70$, what is $m\widehat{AC}$?

- 1) 110
- 2) 70
- 3) 55
- 4) 35

216 Which graph represents a circle whose equation is $(x + 2)^2 + y^2 = 16$?

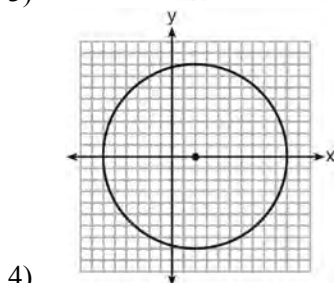
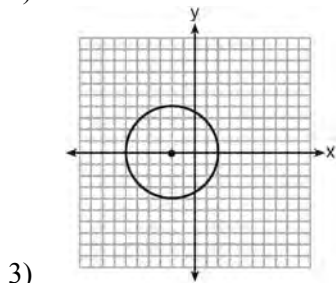
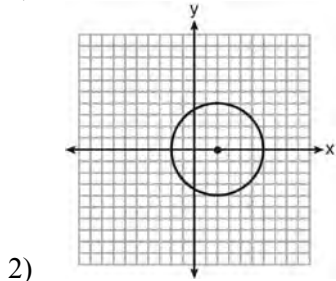
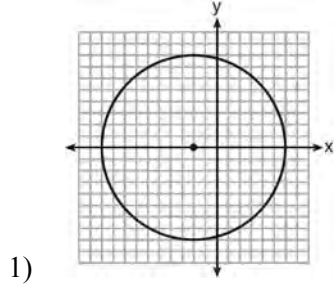

217 In $\triangle DEF$, $m\angle D = 3x + 5$, $m\angle E = 4x - 15$, and $m\angle F = 2x + 10$. Which statement is true?

- 1) $DF = FE$
- 2) $DE = FE$
- 3) $m\angle E = m\angle F$
- 4) $m\angle D = m\angle F$

218 In scalene triangle ABC , $m\angle B = 45$ and $m\angle C = 55$. What is the order of the sides in length, from longest to shortest?

- 1) $\overline{AB}, \overline{BC}, \overline{AC}$
- 2) $\overline{BC}, \overline{AC}, \overline{AB}$
- 3) $\overline{AC}, \overline{BC}, \overline{AB}$
- 4) $\overline{BC}, \overline{AB}, \overline{AC}$

219 In the diagram below, point P is the centroid of $\triangle ABC$.

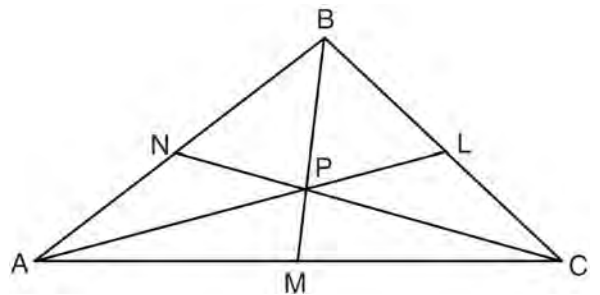

If $PM = 2x + 5$ and $BP = 7x + 4$, what is the length of \overline{PM} ?

- 1) 9
- 2) 2
- 3) 18
- 4) 27

220 Which equation represents the line parallel to the line whose equation is $4x + 2y = 14$ and passing through the point $(2, 2)$?

- 1) $y = -2x$
- 2) $y = -2x + 6$
- 3) $y = \frac{1}{2}x$
- 4) $y = \frac{1}{2}x + 1$

- 221 When $\triangle ABC$ is dilated by a scale factor of 2, its image is $\triangle A'B'C'$. Which statement is true?
- 1) $\overline{AC} \cong \overline{A'C'}$
 - 2) $\angle A \cong \angle A'$
 - 3) perimeter of $\triangle ABC =$ perimeter of $\triangle A'B'C'$
 - 4) $2(\text{area of } \triangle ABC) = \text{area of } \triangle A'B'C'$

- 222 The vertices of the triangle in the diagram below are $A(7,9)$, $B(3,3)$, and $C(11,3)$.

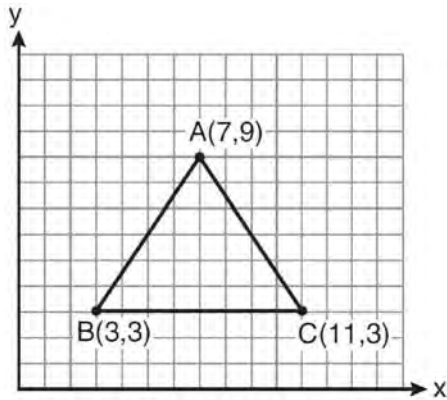

What are the coordinates of the centroid of $\triangle ABC$?

- 1) (5,6)
 - 2) (7,3)
 - 3) (7,5)
 - 4) (9,6)
- 223 In a given triangle, the point of intersection of the three medians is the same as the point of intersection of the three altitudes. Which classification of the triangle is correct?
- 1) scalene triangle
 - 2) isosceles triangle
 - 3) equilateral triangle
 - 4) right isosceles triangle

- 224 In the diagram below, \overline{EF} is the median of trapezoid $ABCD$.

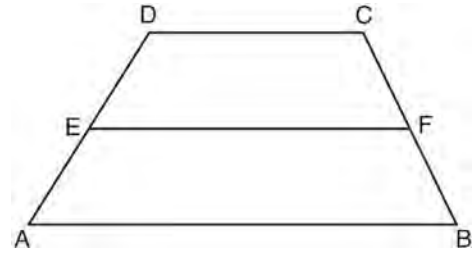

If $AB = 5x - 9$, $DC = x + 3$, and $EF = 2x + 2$, what is the value of x ?

- 1) 5
 - 2) 2
 - 3) 7
 - 4) 8
- 225 In the diagram below of circle O , chord \overline{AB} is parallel to chord \overline{GH} . Chord \overline{CD} intersects \overline{AB} at E and \overline{GH} at F .

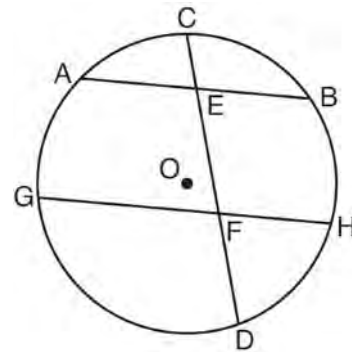

Which statement must always be true?

- 1) $\widehat{AC} \cong \widehat{CB}$
- 2) $\widehat{DH} \cong \widehat{BH}$
- 3) $\widehat{AB} \cong \widehat{GH}$
- 4) $\widehat{AG} \cong \widehat{BH}$

- 226 In $\triangle AED$ with \overline{ABCD} shown in the diagram below, \overline{EB} and \overline{EC} are drawn.

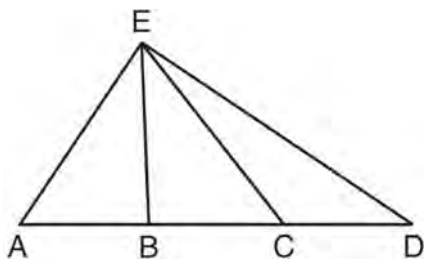

If $\overline{AB} \cong \overline{CD}$, which statement could always be proven?

- 1) $\overline{AC} \cong \overline{DB}$
 - 2) $\overline{AE} \cong \overline{ED}$
 - 3) $\overline{AB} \cong \overline{BC}$
 - 4) $\overline{EC} \cong \overline{EA}$
- 227 In the diagram below of $\triangle ABC$, \overline{BC} is extended to D .

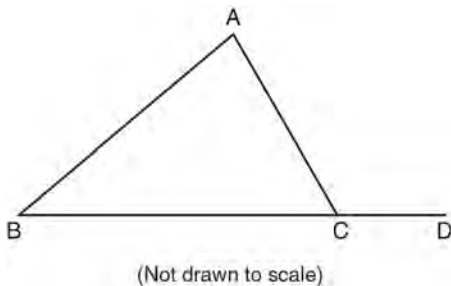

If $m\angle A = x^2 - 6x$, $m\angle B = 2x - 3$, and $m\angle ACD = 9x + 27$, what is the value of x ?

- 1) 10
- 2) 2
- 3) 3
- 4) 15

- 228 The angle formed by the radius of a circle and a tangent to that circle has a measure of

- 1) 45°
- 2) 90°
- 3) 135°
- 4) 180°

- 229 In the diagram below, $\triangle A'B'C'$ is a transformation of $\triangle ABC$, and $\triangle A''B''C''$ is a transformation of $\triangle A'B'C'$.

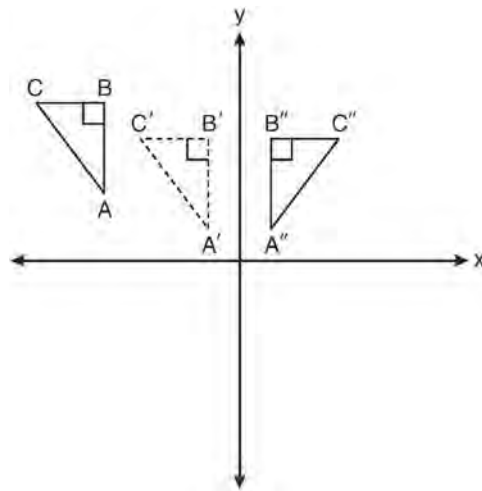

The composite transformation of $\triangle ABC$ to $\triangle A''B''C''$ is an example of a

- 1) reflection followed by a rotation
- 2) reflection followed by a translation
- 3) translation followed by a rotation
- 4) translation followed by a reflection

- 230 The two lines represented by the equations below are graphed on a coordinate plane.

$$x + 6y = 12$$

$$3(x - 2) = -y - 4$$

Which statement best describes the two lines?

- 1) The lines are parallel.
 - 2) The lines are the same line.
 - 3) The lines are perpendicular.
 - 4) The lines intersect at an angle other than 90° .
- 231 What is the length of \overline{AB} with endpoints $A(-1, 0)$ and $B(4, -3)$?
- 1) $\sqrt{6}$
 - 2) $\sqrt{18}$
 - 3) $\sqrt{34}$
 - 4) $\sqrt{50}$

- 232 In the diagram below of circle O , radius \overline{OC} is 5 cm. Chord \overline{AB} is 8 cm and is perpendicular to \overline{OC} at point P .

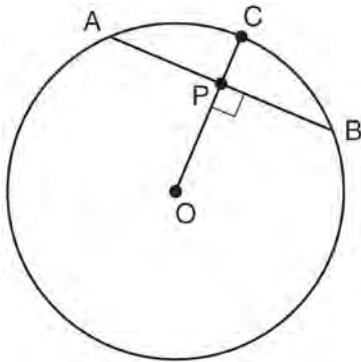

What is the length of \overline{OP} , in centimeters?

- 1) 8
- 2) 2
- 3) 3
- 4) 4

- 233 What is the image of the point $(-5, 2)$ under the translation $T_{3, -4}$?

- 1) $(-9, 5)$
- 2) $(-8, 6)$
- 3) $(-2, -2)$
- 4) $(-15, -8)$

- 234 Which set of numbers does *not* represent the sides of a right triangle?

- 1) $\{6, 8, 10\}$
- 2) $\{8, 15, 17\}$
- 3) $\{8, 24, 25\}$
- 4) $\{15, 36, 39\}$

- 235 In the diagram of $\triangle ABC$ shown below, $\overline{DE} \parallel \overline{BC}$.

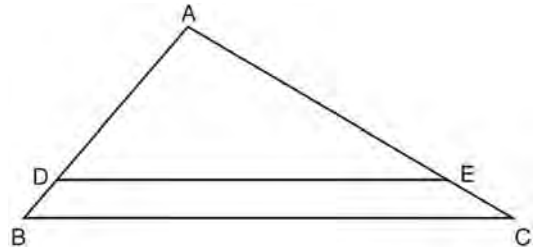

If $AB = 10$, $AD = 8$, and $AE = 12$, what is the length of \overline{EC} ?

- 1) 6
- 2) 2
- 3) 3
- 4) 15

- 236 In the diagram below, quadrilateral $JUMP$ is inscribed in a circle..

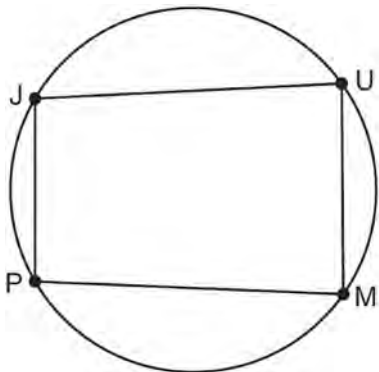

Opposite angles J and M must be

- 1) right
 - 2) complementary
 - 3) congruent
 - 4) supplementary
- 237 What is the slope of a line that is perpendicular to the line represented by the equation $x + 2y = 3$?
- 1) -2
 - 2) 2
 - 3) $-\frac{1}{2}$
 - 4) $\frac{1}{2}$
- 238 What is the equation of a line passing through $(2, -1)$ and parallel to the line represented by the equation $y = 2x + 1$?
- 1) $y = -\frac{1}{2}x$
 - 2) $y = -\frac{1}{2}x + 1$
 - 3) $y = 2x - 5$
 - 4) $y = 2x - 1$

- 239 A sphere is inscribed inside a cube with edges of 6 cm. In cubic centimeters, what is the volume of the sphere, in terms of π ?

- 1) 12π
- 2) 36π
- 3) 48π
- 4) 288π

- 240 What is the measure of each interior angle of a regular hexagon?

- 1) 60°
- 2) 120°
- 3) 135°
- 4) 270°

- 241 In the diagram of quadrilateral $ABCD$, $\overline{AB} \parallel \overline{CD}$, $\angle ABC \cong \angle CDA$, and diagonal \overline{AC} is drawn.

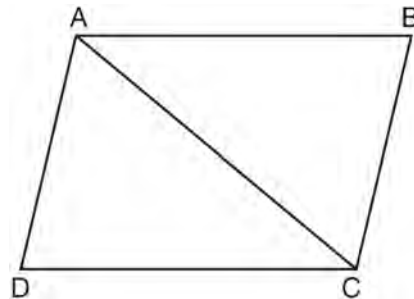

Which method can be used to prove $\triangle ABC$ is congruent to $\triangle CDA$?

- 1) AAS
- 2) SSA
- 3) SAS
- 4) SSS

242 Which diagram shows the construction of the perpendicular bisector of \overline{AB} ?

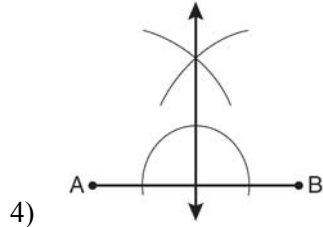
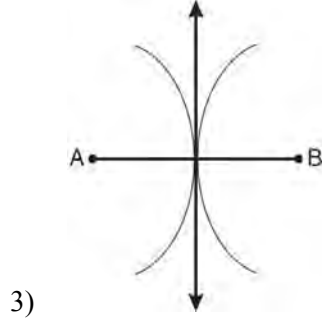
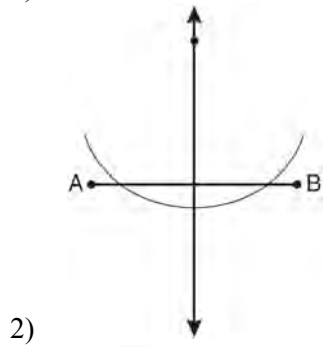
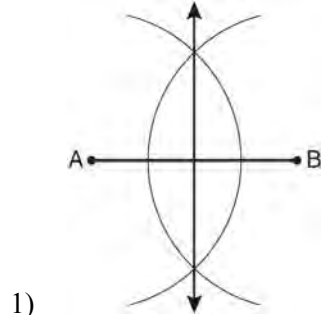

243 Triangle ABC has vertices $A(0, 0)$, $B(3, 2)$, and $C(0, 4)$. The triangle may be classified as

- 1) equilateral
- 2) isosceles
- 3) right
- 4) scalene

244 In $\triangle ABC$, $AB = 5$ feet and $BC = 3$ feet. Which inequality represents all possible values for the length of AC , in feet?

- 1) $2 \leq AC \leq 8$
- 2) $2 < AC < 8$
- 3) $3 \leq AC \leq 7$
- 4) $3 < AC < 7$

245 In the diagram below of circle O , chord \overline{AB} is parallel to chord \overline{CD} .

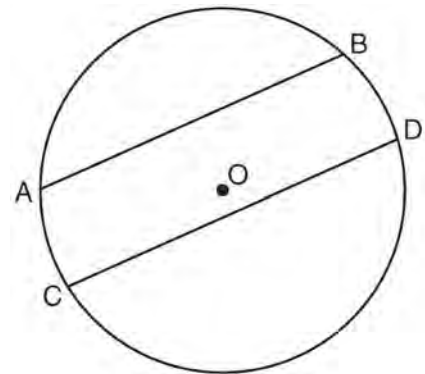

Which statement must be true?

- 1) $\widehat{AC} \cong \widehat{BD}$
- 2) $\widehat{AB} \cong \widehat{CD}$
- 3) $\overline{AB} \cong \overline{CD}$
- 4) $\widehat{ABD} \cong \widehat{CDB}$

246 In the diagram below, $\triangle ABC \sim \triangle RST$.

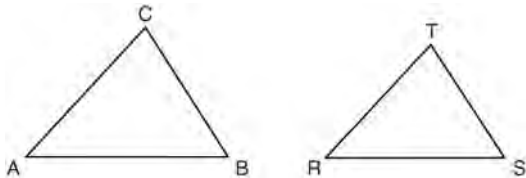

Which statement is *not* true?

- 1) $\angle A \cong \angle R$
- 2) $\frac{AB}{RS} = \frac{BC}{ST}$
- 3) $\frac{AB}{BC} = \frac{ST}{RS}$
- 4) $\frac{AB + BC + AC}{RS + ST + RT} = \frac{AB}{RS}$

247 In the diagram below of $\triangle ABC$, D is the midpoint of \overline{AB} , and E is the midpoint of \overline{BC} .

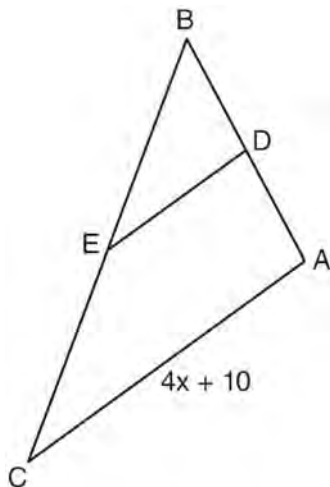

If $AC = 4x + 10$, which expression represents DE ?

- 1) $x + 2.5$
- 2) $2x + 5$
- 3) $2x + 10$
- 4) $8x + 20$

248 In $\triangle FGH$, $m\angle F = 42$ and an exterior angle at vertex H has a measure of 104. What is $m\angle G$?

- 1) 34
- 2) 62
- 3) 76
- 4) 146

249 Which statement is true about every parallelogram?

- 1) All four sides are congruent.
- 2) The interior angles are all congruent.
- 3) Two pairs of opposite sides are congruent.
- 4) The diagonals are perpendicular to each other.

250 In the diagram below of $\triangle ABC$, side \overline{BC} is extended to point D , $m\angle A = x$, $m\angle B = 2x + 15$, and $m\angle ACD = 5x + 5$.

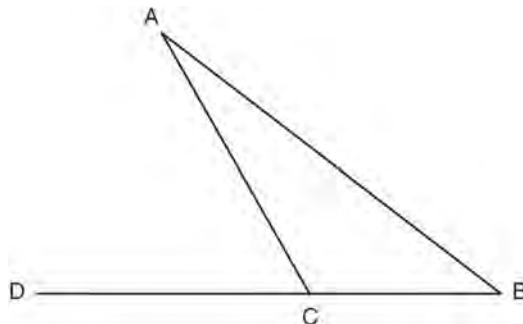

What is $m\angle B$?

- 1) 5
- 2) 20
- 3) 25
- 4) 55

Geometry Multiple Choice Regents Exam Questions

- 251 Which transformation is *not* always an isometry?
- 1) rotation
 - 2) dilation
 - 3) reflection
 - 4) translation

- 252 Which illustration shows the correct construction of an angle bisector?

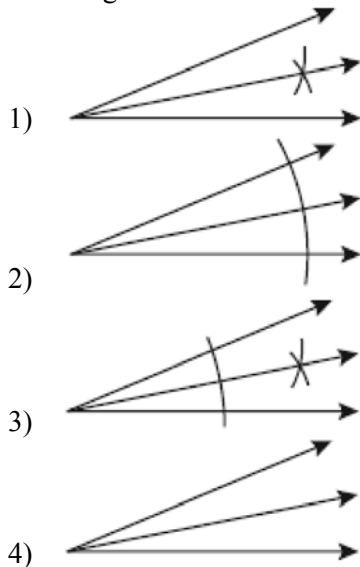

- 253 In plane \mathcal{P} , lines m and n intersect at point A . If line k is perpendicular to line m and line n at point A , then line k is
- 1) contained in plane \mathcal{P}
 - 2) parallel to plane \mathcal{P}
 - 3) perpendicular to plane \mathcal{P}
 - 4) skew to plane \mathcal{P}

- 254 In the diagram of $\triangle ABC$ below, Jose found centroid P by constructing the three medians. He measured \overline{CF} and found it to be 6 inches.

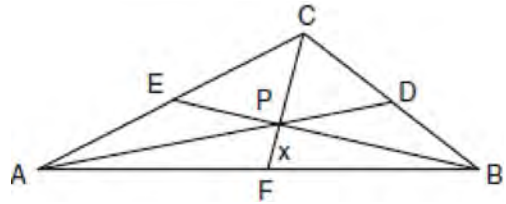

If $PF = x$, which equation can be used to find x ?

- 1) $x + x = 6$
 - 2) $2x + x = 6$
 - 3) $3x + 2x = 6$
 - 4) $x + \frac{2}{3}x = 6$
- 255 A rectangular prism has a volume of $3x^2 + 18x + 24$. Its base has a length of $x + 2$ and a width of 3. Which expression represents the height of the prism?
- 1) $x + 4$
 - 2) $x + 2$
 - 3) 3
 - 4) $x^2 + 6x + 8$
- 256 A transversal intersects two lines. Which condition would always make the two lines parallel?
- 1) Vertical angles are congruent.
 - 2) Alternate interior angles are congruent.
 - 3) Corresponding angles are supplementary.
 - 4) Same-side interior angles are complementary.

Geometry Multiple Choice Regents Exam Questions

www.jmap.org

- 257 The pentagon in the diagram below is formed by five rays.

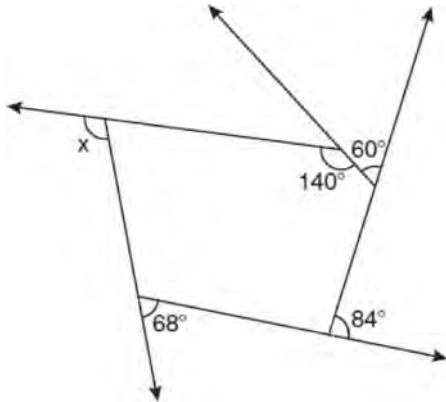

What is the degree measure of angle x ?

- 1) 72
 - 2) 96
 - 3) 108
 - 4) 112
- 258 The diagram below shows the construction of the bisector of $\angle ABC$.

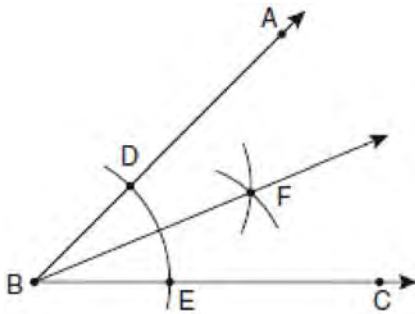

Which statement is *not* true?

- 259 The diagram below shows the construction of a line through point P perpendicular to line m .

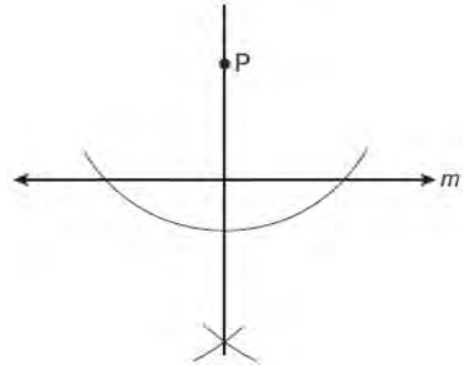

Which statement is demonstrated by this construction?

- 1) If a line is parallel to a line that is perpendicular to a third line, then the line is also perpendicular to the third line.
 - 2) The set of points equidistant from the endpoints of a line segment is the perpendicular bisector of the segment.
 - 3) Two lines are perpendicular if they are equidistant from a given point.
 - 4) Two lines are perpendicular if they intersect to form a vertical line.
- 260 Through a given point, P , on a plane, how many lines can be drawn that are perpendicular to that plane?
- 1) 1
 - 2) 2
 - 3) more than 2
 - 4) none

- 261 In the diagram below of circle O , chords \overline{AE} and \overline{DC} intersect at point B , such that $m\widehat{AC} = 36$ and $m\widehat{DE} = 20$.

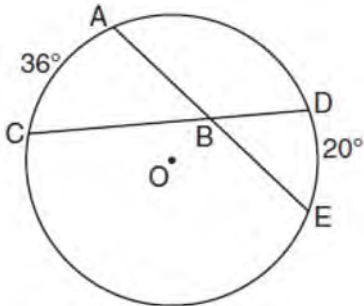

What is $m\angle ABC$?

- 1) 56
 - 2) 36
 - 3) 28
 - 4) 8
- 262 What is an equation of the line that contains the point $(3, -1)$ and is perpendicular to the line whose equation is $y = -3x + 2$?
- 1) $y = -3x + 8$
 - 2) $y = -3x$
 - 3) $y = \frac{1}{3}x$
 - 4) $y = \frac{1}{3}x - 2$
- 263 A right circular cylinder has a volume of 1,000 cubic inches and a height of 8 inches. What is the radius of the cylinder to the nearest tenth of an inch?
- 1) 6.3
 - 2) 11.2
 - 3) 19.8
 - 4) 39.8

- 264 Which diagram shows the construction of an equilateral triangle?

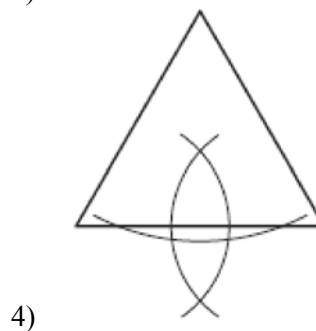
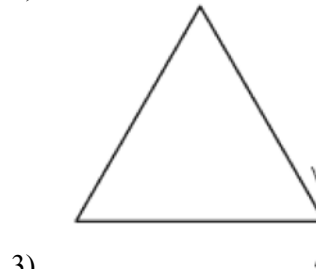
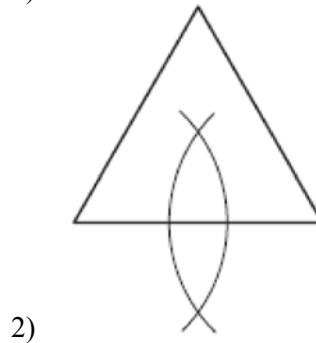
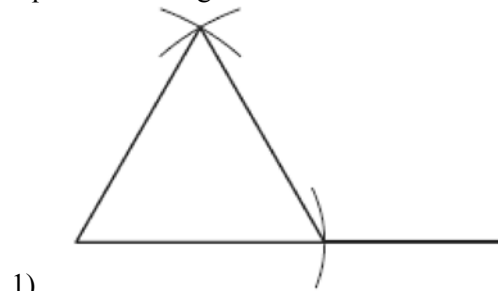

Geometry Multiple Choice Regents Exam Questions

www.jmap.org

- 265 Which equation represents the circle whose center is $(-2, 3)$ and whose radius is 5?
- 1) $(x - 2)^2 + (y + 3)^2 = 5$
 - 2) $(x + 2)^2 + (y - 3)^2 = 5$
 - 3) $(x + 2)^2 + (y - 3)^2 = 25$
 - 4) $(x - 2)^2 + (y + 3)^2 = 25$

- 266 What is the length, to the *nearest tenth*, of the line segment joining the points $(-4, 2)$ and $(146, 52)$?
- 1) 141.4
 - 2) 150.5
 - 3) 151.9
 - 4) 158.1

- 267 Which expression best describes the transformation shown in the diagram below?

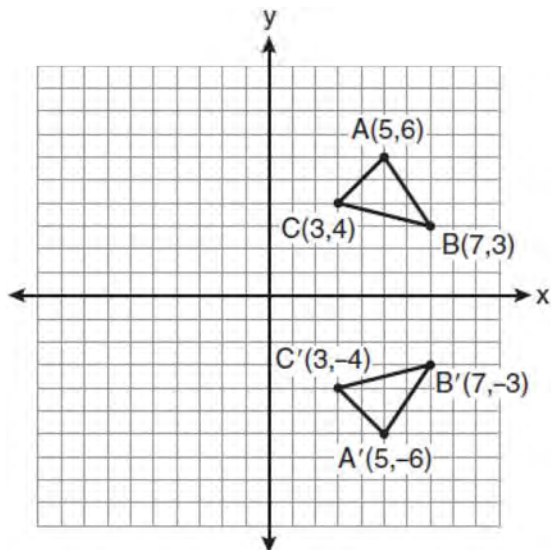

- 1) same orientation; reflection
- 2) opposite orientation; reflection
- 3) same orientation; translation
- 4) opposite orientation; translation

- 268 What is the slope of a line perpendicular to the line whose equation is $y = 3x + 4$?

- 1) $\frac{1}{3}$
- 2) $-\frac{1}{3}$
- 3) 3
- 4) -3

- 269 In the diagram below of $\triangle ABC$, \overline{CD} is the bisector of $\angle BCA$, \overline{AE} is the bisector of $\angle CAB$, and \overline{BG} is drawn.

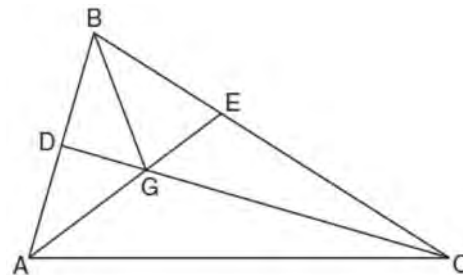

Which statement must be true?

- 1) $DG = EG$
- 2) $AG = BG$
- 3) $\angle AEB \cong \angle AEC$
- 4) $\angle DBG \cong \angle EBG$

- 270 Given $\triangle ABC \sim \triangle DEF$ such that $\frac{AB}{DE} = \frac{3}{2}$. Which statement is *not* true?

- 1) $\frac{BC}{EF} = \frac{3}{2}$
- 2) $\frac{m\angle A}{m\angle D} = \frac{3}{2}$
- 3) $\frac{\text{area of } \triangle ABC}{\text{area of } \triangle DEF} = \frac{9}{4}$
- 4) $\frac{\text{perimeter of } \triangle ABC}{\text{perimeter of } \triangle DEF} = \frac{3}{2}$

Geometry Multiple Choice Regents Exam Questions

www.jmap.org

- 271 In the diagram of $\triangle ABC$ and $\triangle DEF$ below, $\overline{AB} \cong \overline{DE}$, $\angle A \cong \angle D$, and $\angle B \cong \angle E$.

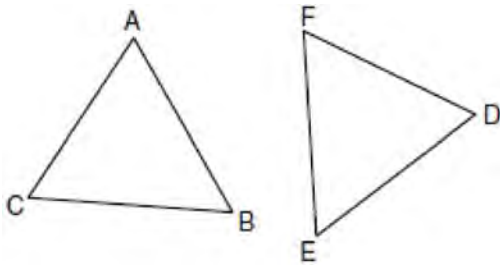

Which method can be used to prove $\triangle ABC \cong \triangle DEF$?

- 1) SSS
 - 2) SAS
 - 3) ASA
 - 4) HL
- 272 In the diagram below of circle O , chord $\overline{AB} \parallel \overline{CD}$, and chord $\overline{CD} \parallel \overline{EF}$.

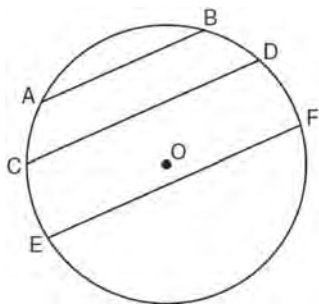

Which statement must be true?

- 273 The diagram below illustrates the construction of \overleftrightarrow{PS} parallel to \overleftrightarrow{RQ} through point P .

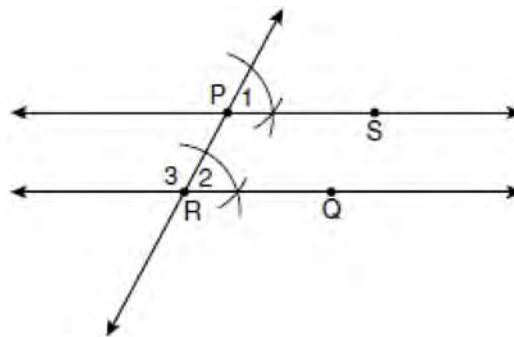

Which statement justifies this construction?

- 1) $m\angle 1 = m\angle 2$
 - 2) $m\angle 1 = m\angle 3$
 - 3) $\overline{PR} \cong \overline{RQ}$
 - 4) $\overline{PS} \cong \overline{RQ}$
- 274 In a coordinate plane, how many points are both 5 units from the origin and 2 units from the x -axis?
- 1) 1
 - 2) 2
 - 3) 3
 - 4) 4
- 275 What is the image of point $A(4, 2)$ after the composition of transformations defined by $R_{90^\circ} \circ r_{y=x}$?
- 1) $(-4, 2)$
 - 2) $(4, -2)$
 - 3) $(-4, -2)$
 - 4) $(2, -4)$

- 276 Lines k_1 and k_2 intersect at point E . Line m is perpendicular to lines k_1 and k_2 at point E .

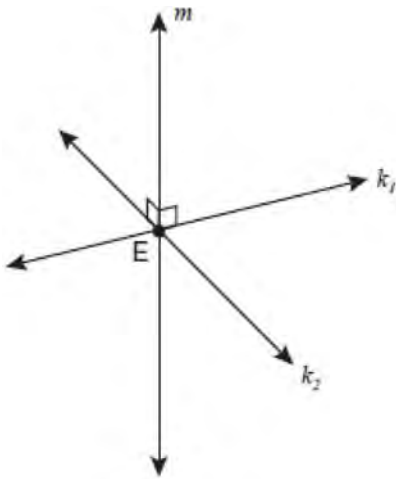

Which statement is always true?

- 1) Lines k_1 and k_2 are perpendicular.
- 2) Line m is parallel to the plane determined by lines k_1 and k_2 .
- 3) Line m is perpendicular to the plane determined by lines k_1 and k_2 .
- 4) Line m is coplanar with lines k_1 and k_2 .

- 277 In the diagram below, $LATE$ is an isosceles trapezoid with $\overline{LE} \cong \overline{AT}$, $LA = 24$, $ET = 40$, and $AT = 10$. Altitudes \overline{LF} and \overline{AG} are drawn.

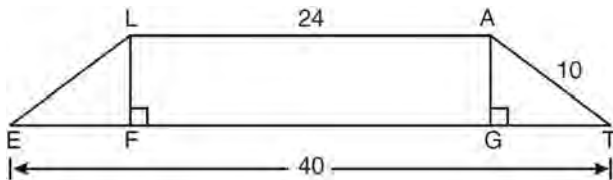

What is the length of \overline{LF} ?

- 1) 6
- 2) 8
- 3) 3
- 4) 4

- 278 The diagram below shows the construction of the perpendicular bisector of \overline{AB} .

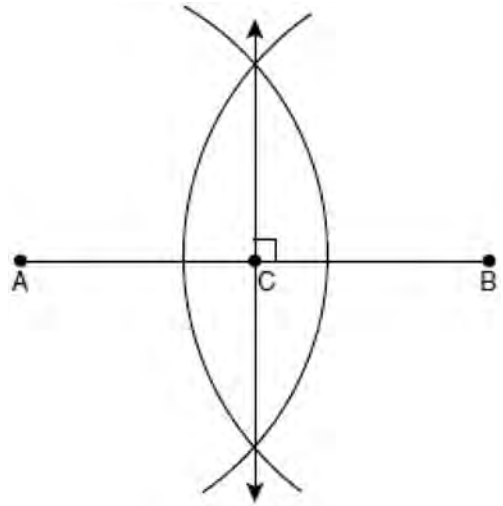

Which statement is *not* true?

- 1) $AC = CB$
- 2) $CB = \frac{1}{2} AB$
- 3) $AC = 2AB$
- 4) $AC + CB = AB$

- 279 What is the converse of the statement "If Bob does his homework, then George gets candy"?
- 1) If George gets candy, then Bob does his homework.
 - 2) Bob does his homework if and only if George gets candy.
 - 3) If George does not get candy, then Bob does not do his homework.
 - 4) If Bob does not do his homework, then George does not get candy.

- 280 In the diagram below, $\triangle ABC$ is shown with \overline{AC} extended through point D .

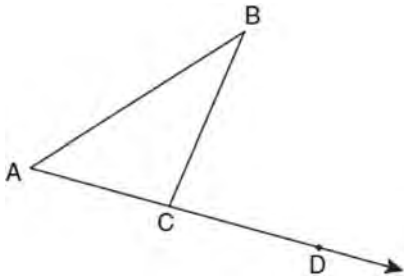

If $m\angle BCD = 6x + 2$, $m\angle BAC = 3x + 15$, and $m\angle ABC = 2x - 1$, what is the value of x ?

- 1) 12
 - 2) $14\frac{10}{11}$
 - 3) 16
 - 4) $18\frac{1}{9}$
- 281 What is the contrapositive of the statement, "If I am tall, then I will bump my head"?
- 1) If I bump my head, then I am tall.
 - 2) If I do not bump my head, then I am tall.
 - 3) If I am tall, then I will not bump my head.
 - 4) If I do not bump my head, then I am not tall.
- 282 What is the slope of a line that is perpendicular to the line whose equation is $3x + 4y = 12$?

- 1) $\frac{3}{4}$
- 2) $-\frac{3}{4}$
- 3) $\frac{4}{3}$
- 4) $-\frac{4}{3}$

- 283 The diagonal \overline{AC} is drawn in parallelogram $ABCD$. Which method can *not* be used to prove that $\triangle ABC \cong \triangle CDA$?

- 1) SSS
- 2) SAS
- 3) SSA
- 4) ASA

- 284 The diagram below shows the construction of the center of the circle circumscribed about $\triangle ABC$.

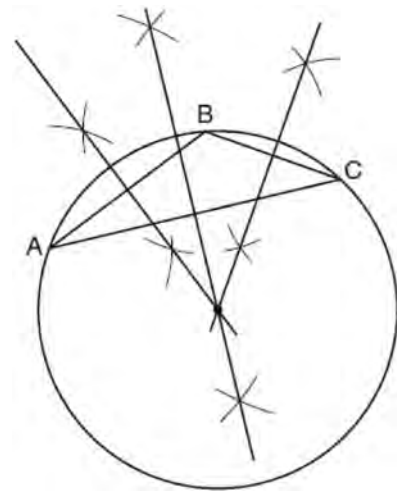

This construction represents how to find the intersection of

- 1) the angle bisectors of $\triangle ABC$
- 2) the medians to the sides of $\triangle ABC$
- 3) the altitudes to the sides of $\triangle ABC$
- 4) the perpendicular bisectors of the sides of $\triangle ABC$

- 285 In the diagram below of circle O , chords \overline{AB} and \overline{CD} intersect at E .

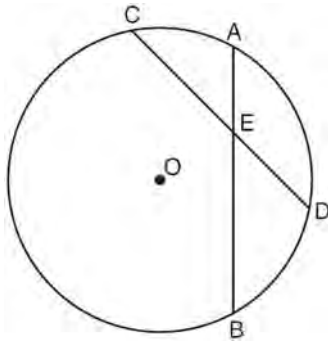

If $\overline{CE} = 10$, $\overline{ED} = 6$, and $\overline{AE} = 4$, what is the length of \overline{EB} ?

- 1) 15
 - 2) 12
 - 3) 6.7
 - 4) 2.4
- 286 If the diagonals of a quadrilateral do *not* bisect each other, then the quadrilateral could be a
- 1) rectangle
 - 2) rhombus
 - 3) square
 - 4) trapezoid
- 287 What is an equation of a circle with its center at $(-3, 5)$ and a radius of 4?

- 1) $(x - 3)^2 + (y + 5)^2 = 16$
- 2) $(x + 3)^2 + (y - 5)^2 = 16$
- 3) $(x - 3)^2 + (y + 5)^2 = 4$
- 4) $(x + 3)^2 + (y - 5)^2 = 4$

- 288 In the diagram below of regular pentagon $ABCDE$, \overline{EB} is drawn.

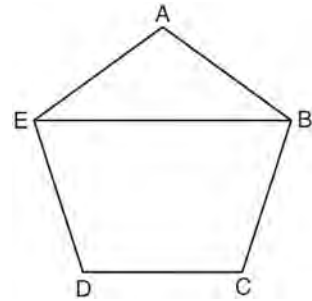

What is the measure of $\angle AEB$?

- 1) 36°
 - 2) 54°
 - 3) 72°
 - 4) 108°
- 289 Which geometric principle is used to justify the construction below?

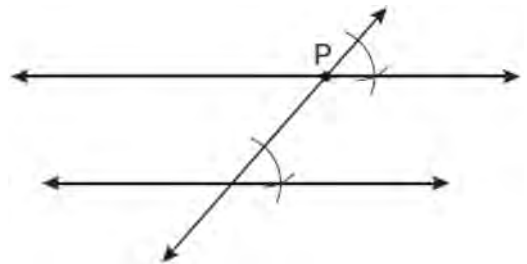

- 1) A line perpendicular to one of two parallel lines is perpendicular to the other.
- 2) Two lines are perpendicular if they intersect to form congruent adjacent angles.
- 3) When two lines are intersected by a transversal and alternate interior angles are congruent, the lines are parallel.
- 4) When two lines are intersected by a transversal and the corresponding angles are congruent, the lines are parallel.

- 290 In the diagram below, $\triangle ABC$ is inscribed in circle P . The distances from the center of circle P to each side of the triangle are shown.

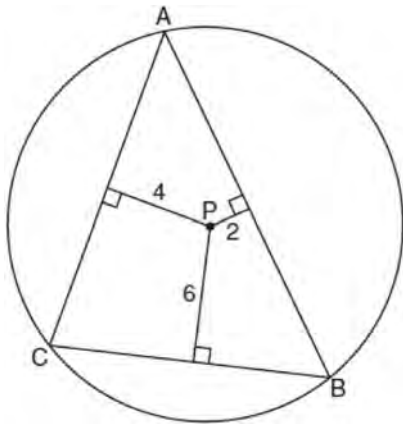

Which statement about the sides of the triangle is true?

- 1) $AB > AC > BC$
 - 2) $AB < AC$ and $AC > BC$
 - 3) $AC > AB > BC$
 - 4) $AC = AB$ and $AB > BC$
- 291 If the endpoints of \overline{AB} are $A(-4, 5)$ and $B(2, -5)$, what is the length of \overline{AB} ?

- 1) $2\sqrt{34}$
- 2) 2
- 3) $\sqrt{61}$
- 4) 8

- 292 If two different lines are perpendicular to the same plane, they are
- 1) collinear
 - 2) coplanar
 - 3) congruent
 - 4) consecutive

- 293 What is the equation of a line that passes through the point $(-3, -11)$ and is parallel to the line whose equation is $2x - y = 4$?

- 1) $y = 2x + 5$
- 2) $y = 2x - 5$
- 3) $y = \frac{1}{2}x + \frac{25}{2}$
- 4) $y = -\frac{1}{2}x - \frac{25}{2}$

- 294 The rectangle $ABCD$ shown in the diagram below will be reflected across the x -axis.

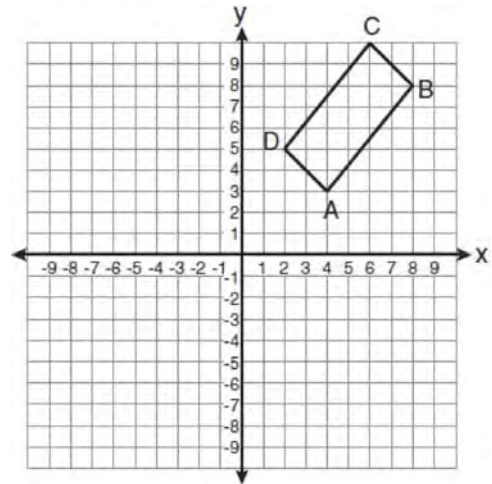

What will *not* be preserved?

- 1) slope of \overline{AB}
- 2) parallelism of \overline{AB} and \overline{CD}
- 3) length of \overline{AB}
- 4) measure of $\angle A$

295 In the diagram below, circle A and circle B are shown.

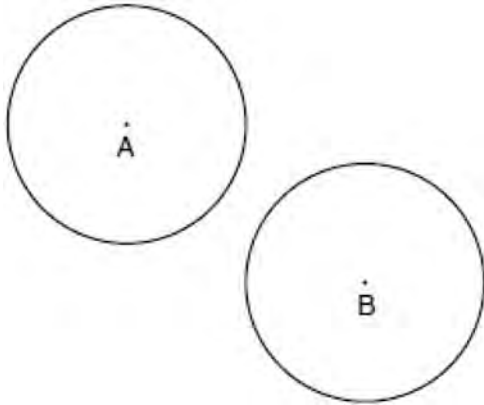

What is the total number of lines of tangency that are common to circle A and circle B ?

- 1) 1
- 2) 2
- 3) 3
- 4) 4

296 In the diagram below of circle O , chords \overline{AD} and \overline{BC} intersect at E , $m\widehat{AC} = 87$, and $m\widehat{BD} = 35$.

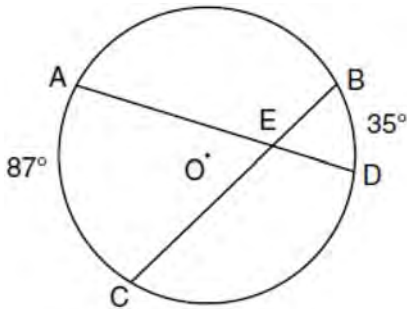

What is the degree measure of $\angle CEA$?

- 1) 87
- 2) 61
- 3) 43.5
- 4) 26

297 Which graph represents a circle with the equation $(x - 5)^2 + (y + 1)^2 = 9$?

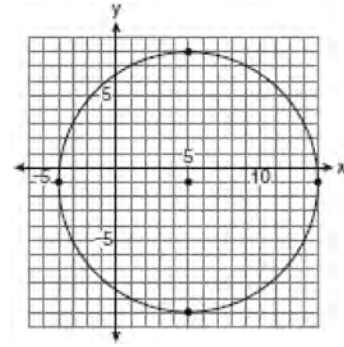
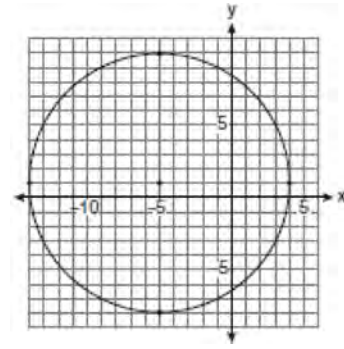
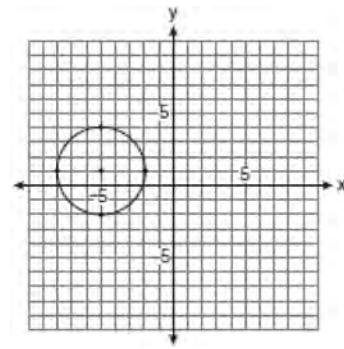
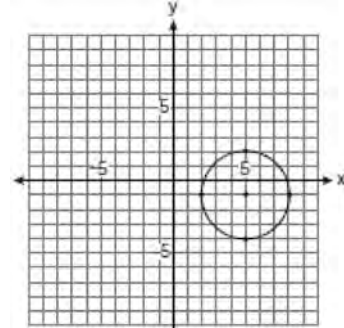

- 298 What is an equation for the circle shown in the graph below?

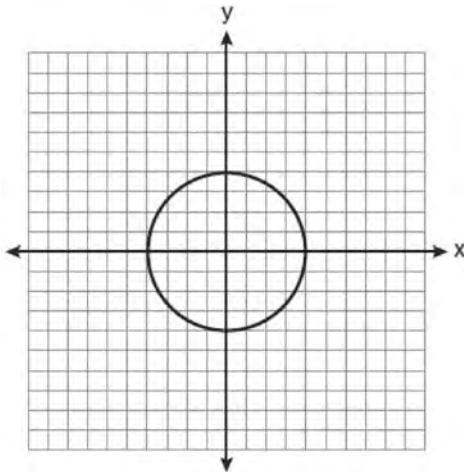

- 1) $x^2 + y^2 = 2$
- 2) $x^2 + y^2 = 4$
- 3) $x^2 + y^2 = 8$
- 4) $x^2 + y^2 = 16$

- 299 In the diagram below of $\triangle ADB$, $m\angle BDA = 90$, $AD = 5\sqrt{2}$, and $AB = 2\sqrt{15}$.

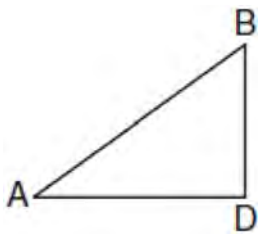

What is the length of \overline{BD} ?

- 1) $\sqrt{10}$
- 2) $\sqrt{20}$
- 3) $\sqrt{50}$
- 4) $\sqrt{110}$

- 300 On the set of axes below, Geoff drew rectangle $ABCD$. He will transform the rectangle by using the translation $(x,y) \rightarrow (x + 2,y + 1)$ and then will reflect the translated rectangle over the x -axis.

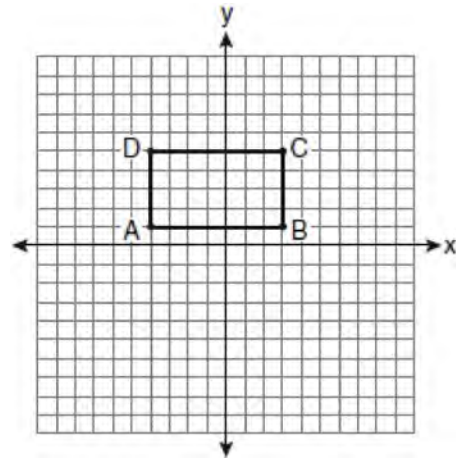

What will be the area of the rectangle after these transformations?

- 1) exactly 28 square units
- 2) less than 28 square units
- 3) greater than 28 square units
- 4) It cannot be determined from the information given.

- 301 In which triangle do the three altitudes intersect outside the triangle?

- 1) a right triangle
- 2) an acute triangle
- 3) an obtuse triangle
- 4) an equilateral triangle

- 302 Point P is on line m . What is the total number of planes that are perpendicular to line m and pass through point P ?

- 1) 1
- 2) 2
- 3) 0
- 4) infinite

Geometry Multiple Choice Regents Exam Questions

www.jmap.org

- 303 In the diagram below of parallelogram $STUV$, $SV = x + 3$, $VU = 2x - 1$, and $TU = 4x - 3$.

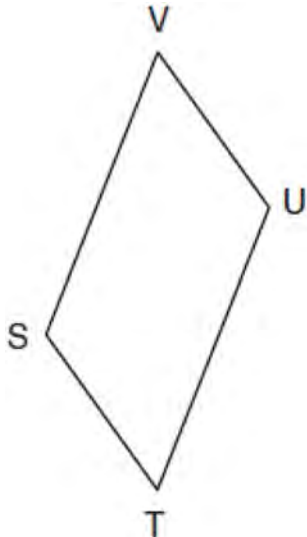

What is the length of \overline{SV} ?

- 1) 5
 - 2) 2
 - 3) 7
 - 4) 4
- 304 Juliann plans on drawing $\triangle ABC$, where the measure of $\angle A$ can range from 50° to 60° and the measure of $\angle B$ can range from 90° to 100° . Given these conditions, what is the correct range of measures possible for $\angle C$?
- 1) 20° to 40°
 - 2) 30° to 50°
 - 3) 80° to 90°
 - 4) 120° to 130°

- 305 What is the negation of the statement “The Sun is shining”?

- 1) It is cloudy.
- 2) It is daytime.
- 3) It is not raining.
- 4) The Sun is not shining.

- 306 In the diagram below, a right circular cone has a diameter of 8 inches and a height of 12 inches.

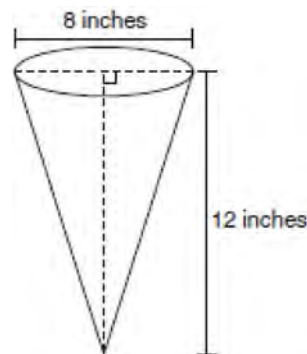

What is the volume of the cone to the nearest cubic inch?

- 1) 201
 - 2) 481
 - 3) 603
 - 4) 804
- 307 In $\triangle ABC$, $AB = 7$, $BC = 8$, and $AC = 9$. Which list has the angles of $\triangle ABC$ in order from smallest to largest?
- 1) $\angle A, \angle B, \angle C$
 - 2) $\angle B, \angle A, \angle C$
 - 3) $\angle C, \angle B, \angle A$
 - 4) $\angle C, \angle A, \angle B$

Geometry Multiple Choice Regents Exam Questions

www.jmap.org

- 308 In the diagram of trapezoid $ABCD$ below, diagonals \overline{AC} and \overline{BD} intersect at E and $\triangle ABC \cong \triangle DCB$.

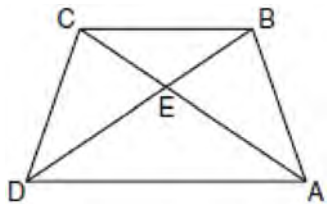

Which statement is true based on the given information?

- 1) $\overline{AC} \cong \overline{BC}$
 - 2) $\overline{CD} \cong \overline{AD}$
 - 3) $\angle CDE \cong \angle BAD$
 - 4) $\angle CDB \cong \angle BAC$
- 309 The figure in the diagram below is a triangular prism.

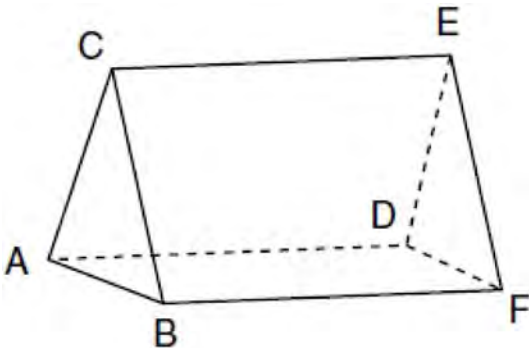

Which statement must be true?

- 1) $\overline{DE} \cong \overline{AB}$
- 2) $\overline{AD} \cong \overline{BC}$
- 3) $\overline{AD} \parallel \overline{CE}$
- 4) $\overline{DE} \parallel \overline{BC}$

- 310 Tangents \overline{PA} and \overline{PB} are drawn to circle O from an external point, P , and radii \overline{OA} and \overline{OB} are drawn. If $m\angle APB = 40^\circ$, what is the measure of $\angle AOB$?

- 1) 140°
- 2) 100°
- 3) 70°
- 4) 50°

- 311 In which polygon does the sum of the measures of the interior angles equal the sum of the measures of the exterior angles?

- 1) triangle
- 2) hexagon
- 3) octagon
- 4) quadrilateral

- 312 What is the slope of a line perpendicular to the line whose equation is $2y = -6x + 8$?

- 1) -3
- 2) $\frac{1}{6}$
- 3) $\frac{1}{3}$
- 4) -6

- 313 Line segment \overline{AB} has endpoints $A(2, -3)$ and $B(-4, 6)$. What are the coordinates of the midpoint of \overline{AB} ?

- 1) $(-2, 3)$
- 2) $\left(-1, 1\frac{1}{2}\right)$
- 3) $(-1, 3)$
- 4) $\left(3, 4\frac{1}{2}\right)$

314 In the diagram below, $\triangle ABC \cong \triangle XYZ$.

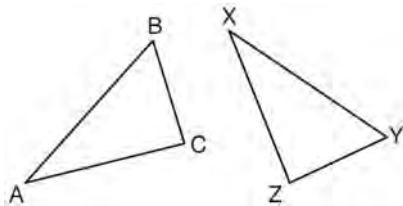

Which two statements identify corresponding congruent parts for these triangles?

- 1) $\overline{AB} \cong \overline{XY}$ and $\angle C \cong \angle Y$
- 2) $\overline{AB} \cong \overline{YZ}$ and $\angle C \cong \angle X$
- 3) $\overline{BC} \cong \overline{XY}$ and $\angle A \cong \angle Y$
- 4) $\overline{BC} \cong \overline{YZ}$ and $\angle A \cong \angle X$

315 In the diagram below of $\triangle AGE$ and $\triangle OLD$, $\angle GAE \cong \angle LOD$, and $\overline{AE} \cong \overline{OD}$.

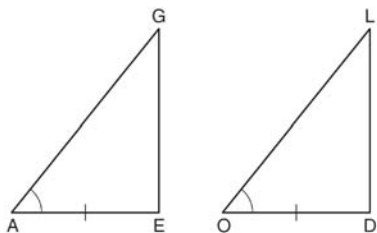

To prove that $\triangle AGE$ and $\triangle OLD$ are congruent by SAS, what other information is needed?

- 1) $\overline{GE} \cong \overline{LD}$
- 2) $\overline{AG} \cong \overline{OL}$
- 3) $\angle AGE \cong \angle OLD$
- 4) $\angle AEG \cong \angle ODL$

316 The lateral faces of a regular pyramid are composed of

- 1) squares
- 2) rectangles
- 3) congruent right triangles
- 4) congruent isosceles triangles

317 In the diagram below of $\triangle ABC$, medians \overline{AD} , \overline{BE} , and \overline{CF} intersect at G .

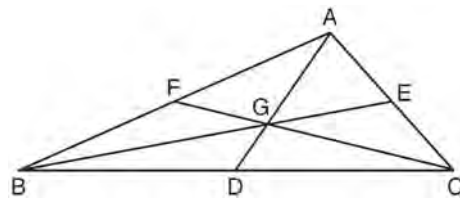

If $CF = 24$, what is the length of \overline{FG} ?

- 1) 8
- 2) 10
- 3) 12
- 4) 16

318 How many common tangent lines can be drawn to the two externally tangent circles shown below?

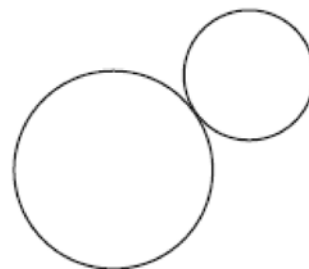

- 1) 1
- 2) 2
- 3) 3
- 4) 4

319 A circle is represented by the equation $x^2 + (y + 3)^2 = 13$. What are the coordinates of the center of the circle and the length of the radius?

- 1) (0, 3) and 13
- 2) (0, 3) and $\sqrt{13}$
- 3) (0, -3) and 13
- 4) (0, -3) and $\sqrt{13}$

320 The coordinates of the vertices of parallelogram $ABCD$ are $A(-3, 2)$, $B(-2, -1)$, $C(4, 1)$, and $D(3, 4)$. The slopes of which line segments could be calculated to show that $ABCD$ is a rectangle?

- 1) \overline{AB} and \overline{DC}
- 2) \overline{AB} and \overline{BC}
- 3) \overline{AD} and \overline{BC}
- 4) \overline{AC} and \overline{BD}

321 In the diagram below, the vertices of $\triangle DEF$ are the midpoints of the sides of equilateral triangle ABC , and the perimeter of $\triangle ABC$ is 36 cm.

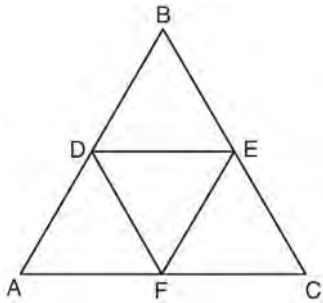

What is the length, in centimeters, of \overline{EF} ?

- 1) 6
- 2) 12
- 3) 18
- 4) 4

322 Given the equations: $y = x^2 - 6x + 10$

$$y + x = 4$$

What is the solution to the given system of equations?

- 1) (2, 3)
- 2) (3, 2)
- 3) (2, 2) and (1, 3)
- 4) (2, 2) and (3, 1)

323 In the diagram below, tangent \overline{AB} and secant \overline{ACD} are drawn to circle O from an external point A , $AB = 8$, and $AC = 4$.

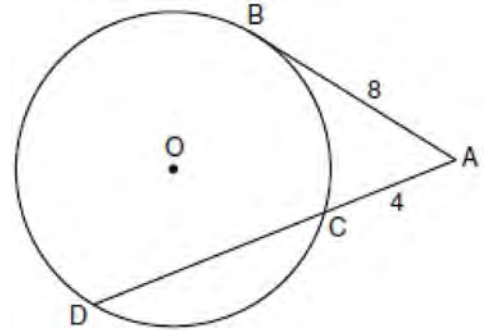

What is the length of \overline{CD} ?

- 1) 16
- 2) 13
- 3) 12
- 4) 10

324 Which expression represents the volume, in cubic centimeters, of the cylinder represented in the diagram below?

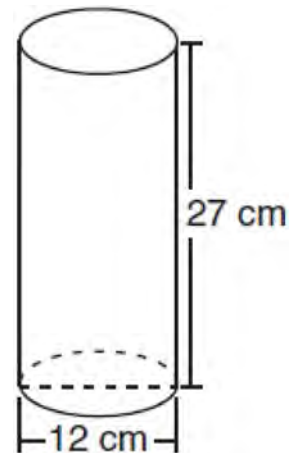

- 1) 162π
- 2) 324π
- 3) 972π
- 4) $3,888\pi$

- 325 In the diagram below of right triangle ACB , altitude \overline{CD} is drawn to hypotenuse \overline{AB} .

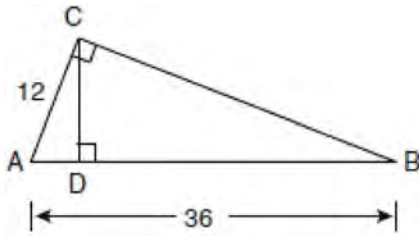

If $AB = 36$ and $AC = 12$, what is the length of \overline{AD} ?

- 1) 32
- 2) 6
- 3) 3
- 4) 4

- 326 In the diagram of circle O below, chord \overline{AB} intersects chord \overline{CD} at E , $DE = 2x + 8$, $EC = 3$, $AE = 4x - 3$, and $EB = 4$.

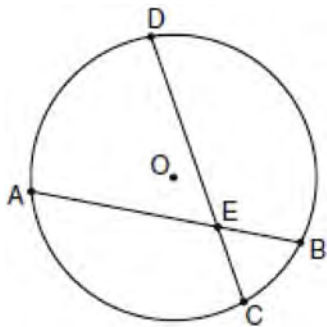

What is the value of x ?

- 1) 1
- 2) 3.6
- 3) 5
- 4) 10.25

- 327 After a composition of transformations, the coordinates $A(4, 2)$, $B(4, 6)$, and $C(2, 6)$ become $A''(-2, -1)$, $B''(-2, -3)$, and $C''(-1, -3)$, as shown on the set of axes below.

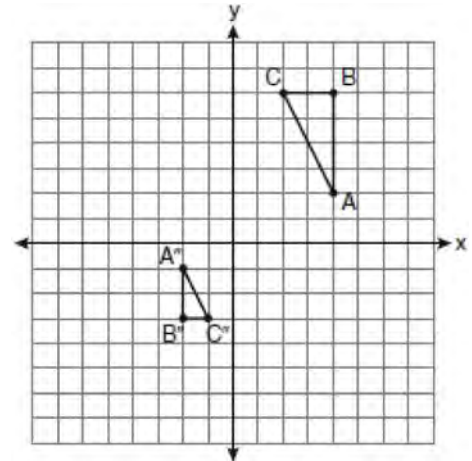

Which composition of transformations was used?

- 1) $R_{180^\circ} \circ D_2$
- 2) $R_{90^\circ} \circ D_2$
- 3) $D_{\frac{1}{2}} \circ R_{180^\circ}$
- 4) $D_{\frac{1}{2}} \circ R_{90^\circ}$

- 328 The equation of a circle is $x^2 + (y - 7)^2 = 16$. What are the center and radius of the circle?

- 1) center = $(0, 7)$; radius = 4
- 2) center = $(0, 7)$; radius = 16
- 3) center = $(0, -7)$; radius = 4
- 4) center = $(0, -7)$; radius = 16

- 329 Which equation represents circle K shown in the graph below?

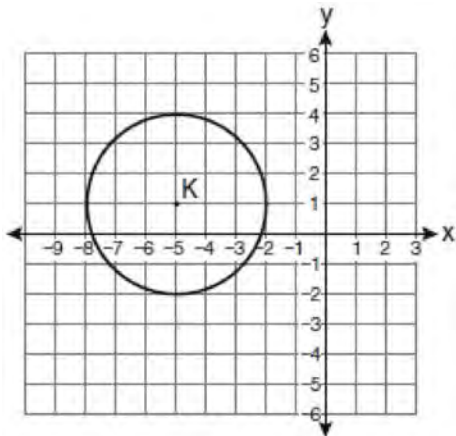

- 1) $(x + 5)^2 + (y - 1)^2 = 3$
 - 2) $(x + 5)^2 + (y - 1)^2 = 9$
 - 3) $(x - 5)^2 + (y + 1)^2 = 3$
 - 4) $(x - 5)^2 + (y + 1)^2 = 9$
- 330 What is the equation of a line that is parallel to the line whose equation is $y = x + 2$?

- 1) $x + y = 5$
- 2) $2x + y = -2$
- 3) $y - x = -1$
- 4) $y - 2x = 3$

- 331 Given: $y = \frac{1}{4}x - 3$

$$y = x^2 + 8x + 12$$

In which quadrant will the graphs of the given equations intersect?

- 1) I
- 2) II
- 3) III
- 4) IV

- 332 In $\triangle ABC$, $m\angle A = x$, $m\angle B = 2x + 2$, and $m\angle C = 3x + 4$. What is the value of x ?

- 1) 29
- 2) 31
- 3) 59
- 4) 61

- 333 Based on the diagram below, which statement is true?

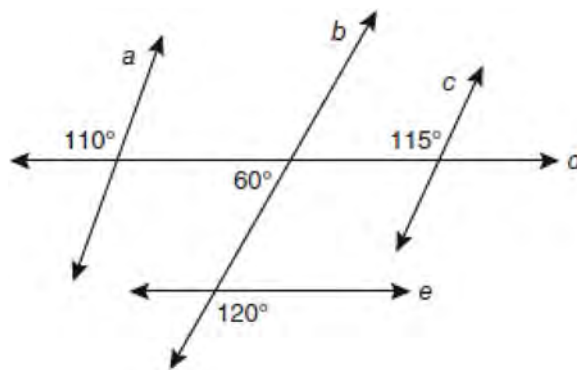

- 1) $a \parallel b$
- 2) $a \parallel c$
- 3) $b \parallel c$
- 4) $d \parallel e$

- 334 Point A is located at $(4, -7)$. The point is reflected in the x -axis. Its image is located at

- 1) $(-4, 7)$
- 2) $(-4, -7)$
- 3) $(4, 7)$
- 4) $(7, -4)$

335 Which set of numbers represents the lengths of the sides of a triangle?

- 1) {5, 18, 13}
- 2) {6, 17, 22}
- 3) {16, 24, 7}
- 4) {26, 8, 15}

336 A transformation of a polygon that always preserves both length and orientation is

- 1) dilation
- 2) translation
- 3) line reflection
- 4) glide reflection

337 Given the system of equations: $y = x^2 - 4x$

$$x = 4$$

The number of points of intersection is

- 1) 1
- 2) 2
- 3) 3
- 4) 0

338 The lines represented by the equations $y + \frac{1}{2}x = 4$

and $3x + 6y = 12$ are

- 1) the same line
- 2) parallel
- 3) perpendicular
- 4) neither parallel nor perpendicular

339 In the diagram of $\triangle ABC$ below, $\overline{AB} \cong \overline{AC}$. The measure of $\angle B$ is 40° .

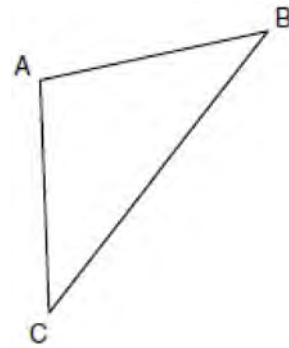

What is the measure of $\angle A$?

- 1) 40°
- 2) 50°
- 3) 70°
- 4) 100°

340 In the diagram of circle O below, chord \overline{CD} is parallel to diameter \overline{AOB} and $m\widehat{AC} = 30$.

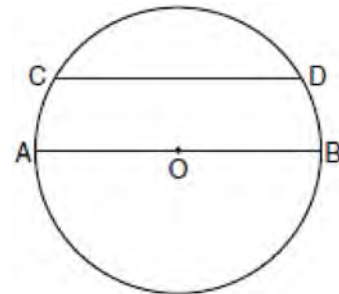

What is $m\widehat{CD}$?

- 1) 150
- 2) 120
- 3) 100
- 4) 60

- 341 In the diagram of $\triangle ABC$ and $\triangle EDC$ below, \overline{AE} and \overline{BD} intersect at C , and $\angle CAB \cong \angle CED$.

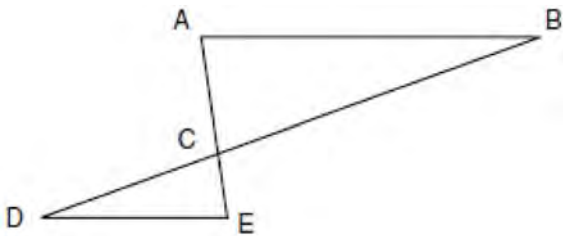

Which method can be used to show that $\triangle ABC$ must be similar to $\triangle EDC$?

- 1) SAS
 - 2) AA
 - 3) SSS
 - 4) HL
- 342 In the diagram below, the length of the legs \overline{AC} and \overline{BC} of right triangle ABC are 6 cm and 8 cm, respectively. Altitude \overline{CD} is drawn to the hypotenuse of $\triangle ABC$.

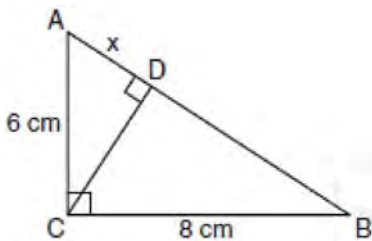

What is the length of \overline{AD} to the nearest tenth of a centimeter?

- 1) 3.6
 - 2) 6.0
 - 3) 6.4
 - 4) 4.0
- 343 What is the slope of a line perpendicular to the line whose equation is $y = -\frac{2}{3}x - 5$?
- 1) $-\frac{3}{2}$
 - 2) $-\frac{2}{3}$
 - 3) $\frac{2}{3}$
 - 4) $\frac{3}{2}$
- 344 Line k is drawn so that it is perpendicular to two distinct planes, P and R . What must be true about planes P and R ?
- 1) Planes P and R are skew.
 - 2) Planes P and R are parallel.
 - 3) Planes P and R are perpendicular.
 - 4) Plane P intersects plane R but is not perpendicular to plane R .
- 345 In the diagram below of $\triangle ACT$, D is the midpoint of \overline{AC} , O is the midpoint of \overline{AT} , and G is the midpoint of \overline{CT} .

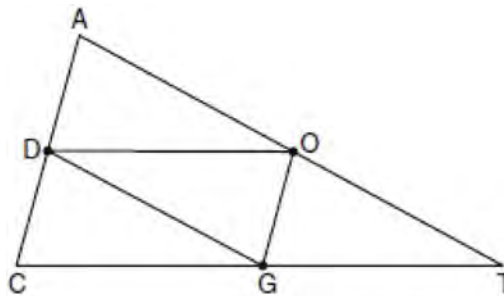

If $AC = 10$, $AT = 18$, and $CT = 22$, what is the perimeter of parallelogram $CDOG$?

- 1) 21
- 2) 25
- 3) 32
- 4) 40

346 The diagram below shows a right pentagonal prism.

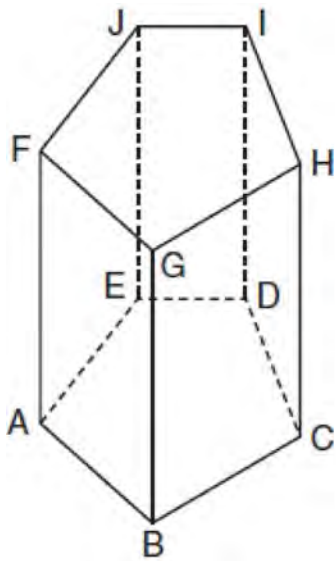

Which statement is always true?

- 1) $\overline{BC} \parallel \overline{ED}$
- 2) $\overline{FG} \parallel \overline{CD}$
- 3) $\overline{FJ} \parallel \overline{IH}$
- 4) $\overline{GB} \parallel \overline{HC}$

347 Which transformation can map the letter **S** onto itself?

- 1) glide reflection
- 2) translation
- 3) line reflection
- 4) rotation

348 What is the distance between the points $(-3, 2)$ and $(1, 0)$?

- 1) $2\sqrt{2}$
- 2) $2\sqrt{3}$
- 3) $5\sqrt{2}$
- 4) $2\sqrt{5}$

349 What is an equation of the line that passes through the point $(7, 3)$ and is parallel to the line $4x + 2y = 10$?

- 1) $y = \frac{1}{2}x - \frac{1}{2}$
- 2) $y = -\frac{1}{2}x + \frac{13}{2}$
- 3) $y = 2x - 11$
- 4) $y = -2x + 17$

350 In $\triangle PQR$, $PQ = 8$, $QR = 12$, and $RP = 13$. Which statement about the angles of $\triangle PQR$ must be true?

- 1) $m\angle Q > m\angle P > m\angle R$
- 2) $m\angle Q > m\angle R > m\angle P$
- 3) $m\angle R > m\angle P > m\angle Q$
- 4) $m\angle P > m\angle R > m\angle Q$

351 One step in a construction uses the endpoints of \overline{AB} to create arcs with the same radii. The arcs intersect above and below the segment. What is the relationship of \overline{AB} and the line connecting the points of intersection of these arcs?

- 1) collinear
- 2) congruent
- 3) parallel
- 4) perpendicular

352 Which statement is logically equivalent to "If it is warm, then I go swimming"?

- 1) If I go swimming, then it is warm.
- 2) If it is warm, then I do not go swimming.
- 3) If I do not go swimming, then it is not warm.
- 4) If it is not warm, then I do not go swimming.

Geometry Multiple Choice Regents Exam Questions

www.jmap.org

- 353 In the diagram below of $\triangle ABC$, D is a point on \overline{AB} , $AC = 7$, $AD = 6$, and $BC = 18$.

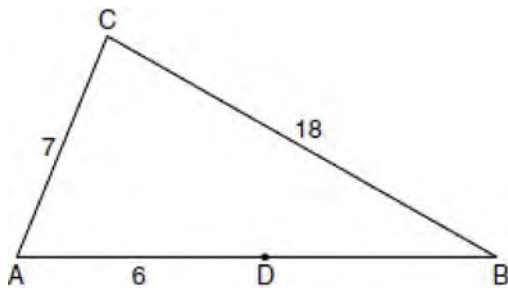

(Not drawn to scale)

The length of \overline{DB} could be

- 1) 5
 - 2) 12
 - 3) 19
 - 4) 25
- 354 In isosceles trapezoid $ABCD$, $\overline{AB} \cong \overline{CD}$. If $BC = 20$, $AD = 36$, and $AB = 17$, what is the length of the altitude of the trapezoid?

- 1) 10
- 2) 12
- 3) 15
- 4) 16

- 355 $\triangle ABC$ is similar to $\triangle DEF$. The ratio of the length of \overline{AB} to the length of \overline{DE} is 3:1. Which ratio is also equal to 3:1?

- 1) $\frac{m\angle A}{m\angle D}$
- 2) $\frac{m\angle B}{m\angle F}$
- 3) $\frac{\text{area of } \triangle ABC}{\text{area of } \triangle DEF}$
- 4) $\frac{\text{perimeter of } \triangle ABC}{\text{perimeter of } \triangle DEF}$

- 356 Which geometric principle is used in the construction shown below?

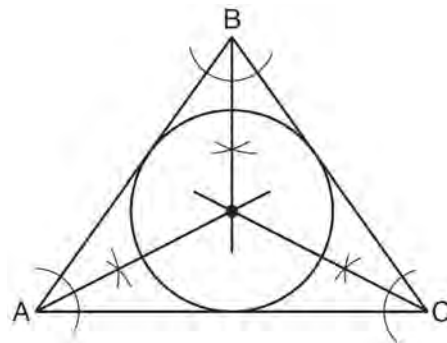

- 1) The intersection of the angle bisectors of a triangle is the center of the inscribed circle.
- 2) The intersection of the angle bisectors of a triangle is the center of the circumscribed circle.
- 3) The intersection of the perpendicular bisectors of the sides of a triangle is the center of the inscribed circle.
- 4) The intersection of the perpendicular bisectors of the sides of a triangle is the center of the circumscribed circle.

- 357 In the diagram below of $\triangle ACT$, $\overline{BE} \parallel \overline{AT}$.

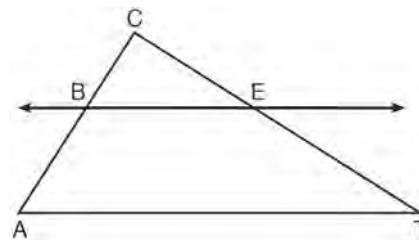

If $CB = 3$, $CA = 10$, and $CE = 6$, what is the length of \overline{ET} ?

- 1) 5
- 2) 14
- 3) 20
- 4) 26

- 358 In the diagram below of parallelogram $ABCD$ with diagonals AC and BD , $m\angle 1 = 45$ and $m\angle DCB = 120$.

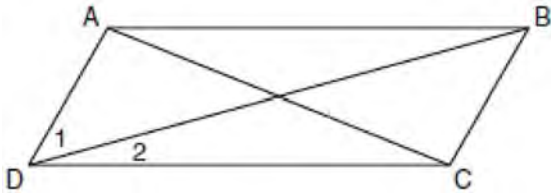

What is the measure of $\angle 2$?

- 1) 15°
 - 2) 30°
 - 3) 45°
 - 4) 60°
- 359 Which transformation produces a figure similar but not congruent to the original figure?
- 1) $T_{1,3}$
 - 2) $D_{\frac{1}{2}}$
 - 3) R_{90°
 - 4) $r_{y=x}$
- 360 Triangle ABC has vertices $A(1, 3)$, $B(0, 1)$, and $C(4, 0)$. Under a translation, A' , the image point of A , is located at $(4, 4)$. Under this same translation, point C' is located at
- 1) $(7, 1)$
 - 2) $(5, 3)$
 - 3) $(3, 2)$
 - 4) $(1, -1)$

- 361 The equation of a circle is $(x - 2)^2 + (y + 4)^2 = 4$. Which diagram is the graph of the circle?

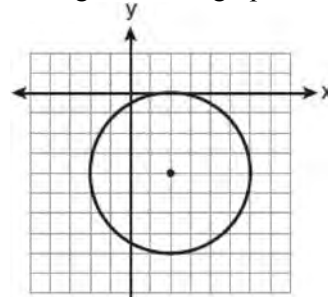

1)

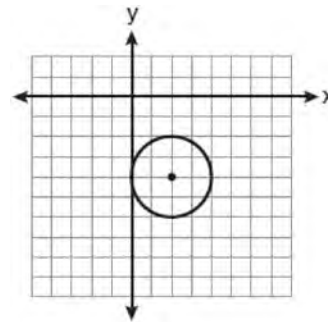

2)

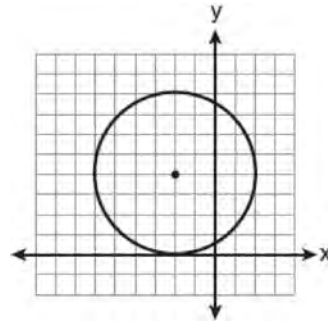

3)

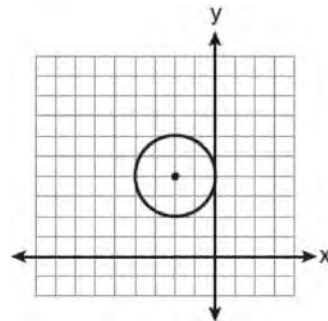

4)

362 In isosceles triangle ABC , $AB = BC$. Which statement will always be true?

- 1) $m\angle B = m\angle A$
- 2) $m\angle A > m\angle B$
- 3) $m\angle A = m\angle C$
- 4) $m\angle C < m\angle B$

363 Which equation represents a line perpendicular to the line whose equation is $2x + 3y = 12$?

- 1) $6y = -4x + 12$
- 2) $2y = 3x + 6$
- 3) $2y = -3x + 6$
- 4) $3y = -2x + 12$

364 Isosceles trapezoid $ABCD$ has diagonals \overline{AC} and \overline{BD} . If $AC = 5x + 13$ and $BD = 11x - 5$, what is the value of x ?

- 1) 28
- 2) $10\frac{3}{4}$
- 3) 3
- 4) $\frac{1}{2}$

365 What is the solution of the following system of equations?

$$y = (x + 3)^2 - 4$$

$$y = 2x + 5$$

- 1) $(0, -4)$
- 2) $(-4, 0)$
- 3) $(-4, -3)$ and $(0, 5)$
- 4) $(-3, -4)$ and $(5, 0)$

366 The diagram below shows \overline{AB} and \overline{DE} .

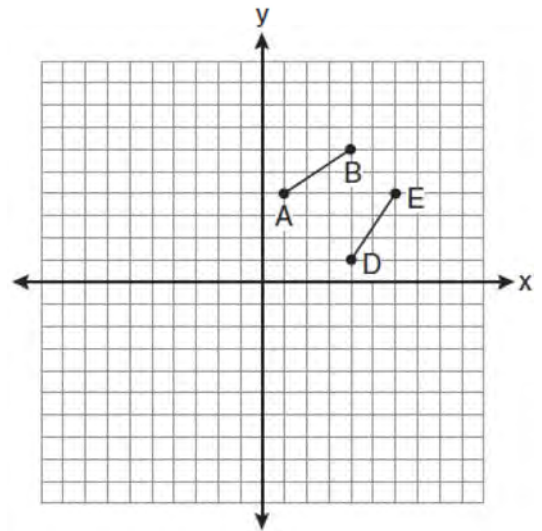

Which transformation will move \overline{AB} onto \overline{DE} such that point D is the image of point A and point E is the image of point B ?

- 1) $T_{3, -3}$
- 2) $D_{\frac{1}{2}}$
- 3) R_{90°
- 4) $r_{y=x}$

367 Side \overline{PQ} of $\triangle PQR$ is extended through Q to point T . Which statement is *not* always true?

- 1) $m\angle RQT > m\angle R$
- 2) $m\angle RQT > m\angle P$
- 3) $m\angle RQT = m\angle P + m\angle R$
- 4) $m\angle RQT > m\angle PQR$

Geometry Multiple Choice Regents Exam Questions

www.jmap.org

- 368 A quadrilateral whose diagonals bisect each other and are perpendicular is a
- 1) rhombus
 - 2) rectangle
 - 3) trapezoid
 - 4) parallelogram

- 369 In the diagram below, which transformation was used to map $\triangle ABC$ to $\triangle A'B'C'$?

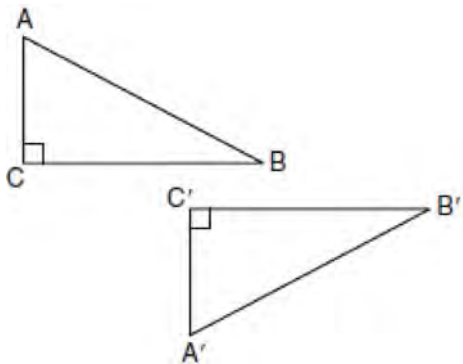

- 1) dilation
 - 2) rotation
 - 3) reflection
 - 4) glide reflection
- 370 What are the center and radius of a circle whose equation is $(x - A)^2 + (y - B)^2 = C$?
- 1) center = (A, B) ; radius = C
 - 2) center = $(-A, -B)$; radius = C
 - 3) center = (A, B) ; radius = \sqrt{C}
 - 4) center = $(-A, -B)$; radius = \sqrt{C}

- 371 Based on the construction below, which statement must be true?

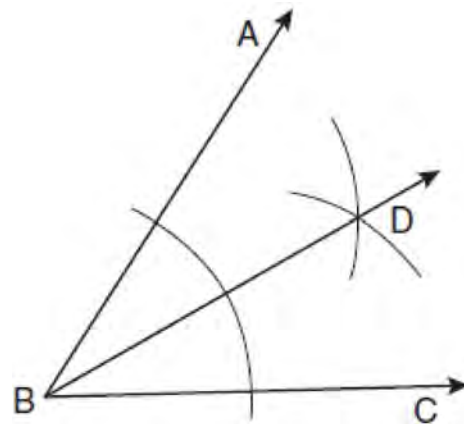

- 1) $m\angle ABD = \frac{1}{2} m\angle CBD$
 - 2) $m\angle ABD = m\angle CBD$
 - 3) $m\angle ABD = m\angle ABC$
 - 4) $m\angle CBD = \frac{1}{2} m\angle ABD$
- 372 In $\triangle ABC$, $m\angle A = 95$, $m\angle B = 50$, and $m\angle C = 35$. Which expression correctly relates the lengths of the sides of this triangle?
- 1) $AB < BC < CA$
 - 2) $AB < AC < BC$
 - 3) $AC < BC < AB$
 - 4) $BC < AC < AB$
- 373 Which equation represents a line parallel to the line whose equation is $2y - 5x = 10$?
- 1) $5y - 2x = 25$
 - 2) $5y + 2x = 10$
 - 3) $4y - 10x = 12$
 - 4) $2y + 10x = 8$

- 374 In the diagram below, under which transformation will $\triangle A'B'C'$ be the image of $\triangle ABC$?

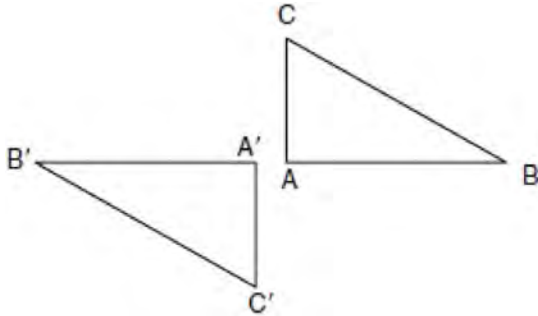

- 1) rotation
 - 2) dilation
 - 3) translation
 - 4) glide reflection
- 375 Lines j and k intersect at point P . Line m is drawn so that it is perpendicular to lines j and k at point P . Which statement is correct?
- 1) Lines j and k are in perpendicular planes.
 - 2) Line m is in the same plane as lines j and k .
 - 3) Line m is parallel to the plane containing lines j and k .
 - 4) Line m is perpendicular to the plane containing lines j and k .
- 376 A right circular cylinder has an altitude of 11 feet and a radius of 5 feet. What is the lateral area, in square feet, of the cylinder, to the *nearest tenth*?
- 1) 172.7
 - 2) 172.8
 - 3) 345.4
 - 4) 345.6

- 377 In the diagram of circle O below, chords \overline{AB} and \overline{CD} are parallel, and \overline{BD} is a diameter of the circle.

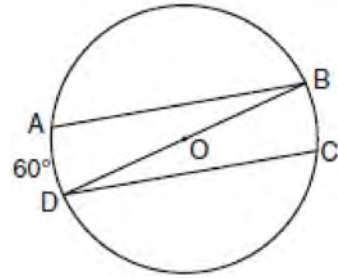

- If $m\widehat{AD} = 60$, what is $m\angle CDB$?
- 1) 20
 - 2) 30
 - 3) 60
 - 4) 120
- 378 The endpoints of \overline{CD} are $C(-2, -4)$ and $D(6, 2)$. What are the coordinates of the midpoint of \overline{CD} ?
- 1) (2, 3)
 - 2) (2, -1)
 - 3) (4, -2)
 - 4) (4, 3)
- 379 What are the center and the radius of the circle whose equation is $(x - 3)^2 + (y + 3)^2 = 36$
- 1) center = (3, -3); radius = 6
 - 2) center = (-3, 3); radius = 6
 - 3) center = (3, -3); radius = 36
 - 4) center = (-3, 3); radius = 36

Geometry Multiple Choice Regents Exam Questions

www.jmap.org

380 If $\triangle ABC \sim \triangle ZXY$, $m\angle A = 50$, and $m\angle C = 30$, what is $m\angle X$?

- 1) 30
- 2) 50
- 3) 80
- 4) 100

381 Two lines are represented by the equations

$-\frac{1}{2}y = 6x + 10$ and $y = mx$. For which value of m

will the lines be parallel?

- 1) -12
- 2) -3
- 3) 3
- 4) 12

382 In the diagram below of circle C , $m\widehat{QT} = 140$, and $m\angle P = 40$.

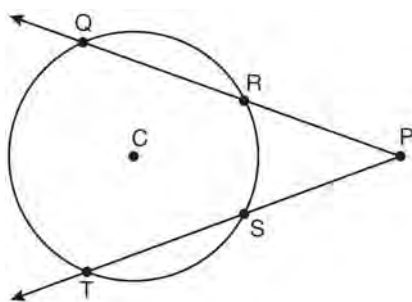

What is $m\widehat{RS}$?

- 1) 50
- 2) 60
- 3) 90
- 4) 110

383 The diameter of a circle has endpoints at $(-2, 3)$ and $(6, 3)$. What is an equation of the circle?

- 1) $(x - 2)^2 + (y - 3)^2 = 16$
- 2) $(x - 2)^2 + (y - 3)^2 = 4$
- 3) $(x + 2)^2 + (y + 3)^2 = 16$
- 4) $(x + 2)^2 + (y + 3)^2 = 4$

384 Square $LMNO$ is shown in the diagram below.

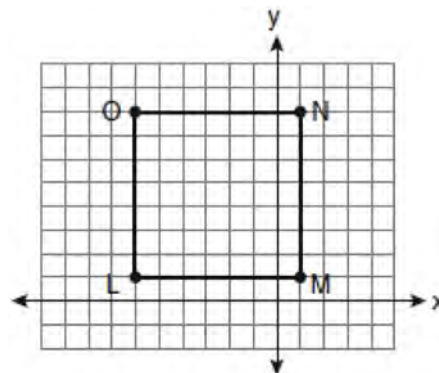

What are the coordinates of the midpoint of diagonal \overline{LN} ?

- 1) $\left(4\frac{1}{2}, -2\frac{1}{2}\right)$
- 2) $\left(-3\frac{1}{2}, 3\frac{1}{2}\right)$
- 3) $\left(-2\frac{1}{2}, 3\frac{1}{2}\right)$
- 4) $\left(-2\frac{1}{2}, 4\frac{1}{2}\right)$

- 385 In the diagram of $\triangle JEA$ below, $m\angle JEA = 90$ and $m\angle EAJ = 48$. Line segment MS connects points M and S on the triangle, such that $m\angle EMS = 59$.

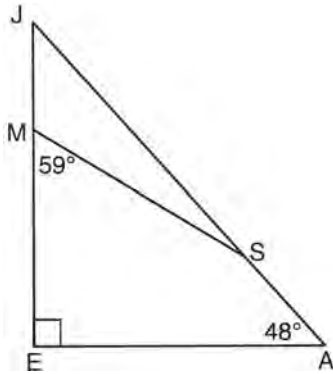

What is $m\angle JSM$?

- 1) 163
 - 2) 121
 - 3) 42
 - 4) 17
- 386 What is the slope of a line perpendicular to the line whose equation is $5x + 3y = 8$?
- 1) $\frac{5}{3}$
 - 2) $\frac{3}{5}$
 - 3) $-\frac{3}{5}$
 - 4) $-\frac{5}{3}$
- 387 What is an equation of the line that passes through the point $(-2, 5)$ and is perpendicular to the line whose equation is $y = \frac{1}{2}x + 5$?
- 1) $y = 2x + 1$
 - 2) $y = -2x + 1$
 - 3) $y = 2x + 9$
 - 4) $y = -2x - 9$

- 388 In the diagram below of circle O , chords \overline{AD} and \overline{BC} intersect at E .

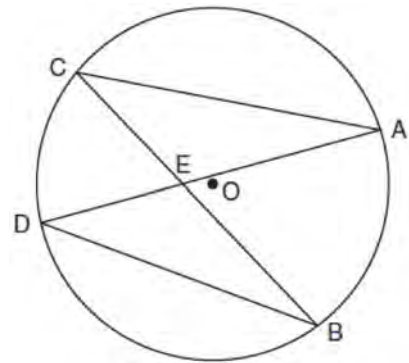

Which relationship must be true?

- 1) $\triangle CAE \cong \triangle DBE$
 - 2) $\triangle AEC \sim \triangle BED$
 - 3) $\angle ACB \cong \angle CBD$
 - 4) $\widehat{CA} \cong \widehat{DB}$
- 389 In the diagram below, line k is perpendicular to plane \mathcal{P} at point T .

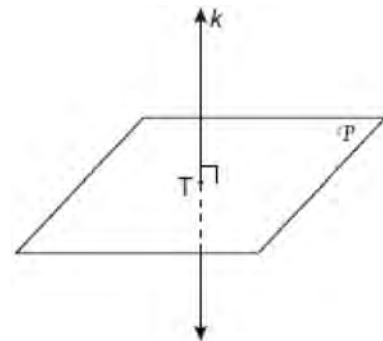

Which statement is true?

- 1) Any point in plane \mathcal{P} also will be on line k .
- 2) Only one line in plane \mathcal{P} will intersect line k .
- 3) All planes that intersect plane \mathcal{P} will pass through T .
- 4) Any plane containing line k is perpendicular to plane \mathcal{P} .

Geometry Multiple Choice Regents Exam Questions

www.jmap.org

- 390 In the diagram below, circle O has a radius of 5, and $\overline{CE} = 2$. Diameter \overline{AC} is perpendicular to chord \overline{BD} at E .

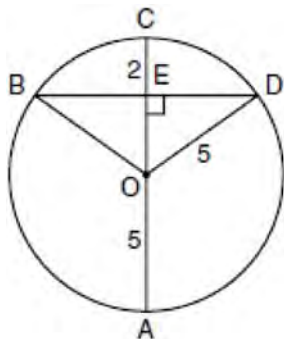

What is the length of \overline{BD} ?

- 1) 12
2) 10
3) 8
4) 4
- 391 Towns A and B are 16 miles apart. How many points are 10 miles from town A and 12 miles from town B ?
- 1) 1
2) 2
3) 3
4) 0
- 392 The lines $3y + 1 = 6x + 4$ and $2y + 1 = x - 9$ are
- 1) parallel
2) perpendicular
3) the same line
4) neither parallel nor perpendicular

- 393 What is the length of the line segment with endpoints $(-6, 4)$ and $(2, -5)$?

- 1) $\sqrt{13}$
2) $\sqrt{17}$
3) $\sqrt{72}$
4) $\sqrt{145}$

- 394 The endpoints of \overline{AB} are $A(3, 2)$ and $B(7, 1)$. If $\overline{A''B''}$ is the result of the transformation of \overline{AB} under $D_2 \circ T_{-4, 3}$ what are the coordinates of A'' and B'' ?

- 1) $A''(-2, 10)$ and $B''(6, 8)$
2) $A''(-1, 5)$ and $B''(3, 4)$
3) $A''(2, 7)$ and $B''(10, 5)$
4) $A''(14, -2)$ and $B''(22, -4)$

- 395 In the diagram below of $\triangle PRT$, Q is a point on \overline{PR} , S is a point on \overline{TR} , \overline{QS} is drawn, and $\angle RPT \cong \angle RSQ$.

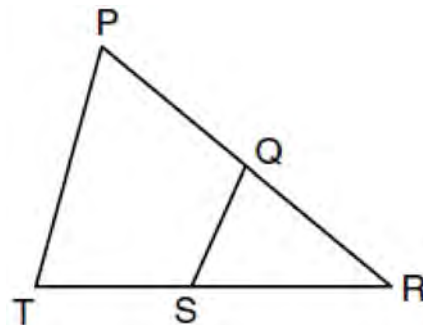

Which reason justifies the conclusion that $\triangle PRT \sim \triangle SRQ$?

- 1) AA
2) ASA
3) SAS
4) SSS

- 396 In the diagram below, \overline{SQ} and \overline{PR} intersect at T , \overline{PQ} is drawn, and $\overline{PS} \parallel \overline{QR}$.

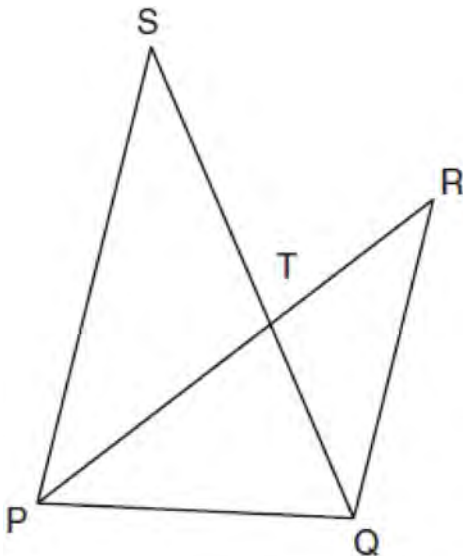

What technique can be used to prove that $\triangle PST \sim \triangle RQT$?

- 1) SAS
 - 2) SSS
 - 3) ASA
 - 4) AA
- 397 If a line segment has endpoints $A(3x + 5, 3y)$ and $B(x - 1, -y)$, what are the coordinates of the midpoint of \overline{AB} ?
- 1) $(x + 3, 2y)$
 - 2) $(2x + 2, y)$
 - 3) $(2x + 3, y)$
 - 4) $(4x + 4, 2y)$
- 398 What is the negation of the statement “I am not going to eat ice cream”?
- 1) I like ice cream.
 - 2) I am going to eat ice cream.
 - 3) If I eat ice cream, then I like ice cream.
 - 4) If I don’t like ice cream, then I don’t eat ice cream.
- 399 In $\triangle ABC$, point D is on \overline{AB} , and point E is on \overline{BC} such that $\overline{DE} \parallel \overline{AC}$. If $DB = 2$, $DA = 7$, and $DE = 3$, what is the length of \overline{AC} ?
- 1) 8
 - 2) 9
 - 3) 10.5
 - 4) 13.5
- 400 The vertices of $\triangle ABC$ are $A(-1, -2)$, $B(-1, 2)$ and $C(6, 0)$. Which conclusion can be made about the angles of $\triangle ABC$?
- 1) $m\angle A = m\angle B$
 - 2) $m\angle A = m\angle C$
 - 3) $m\angle ACB = 90$
 - 4) $m\angle ABC = 60$
- 401 What is the negation of the statement “Squares are parallelograms”?
- 1) Parallelograms are squares.
 - 2) Parallelograms are not squares.
 - 3) It is not the case that squares are parallelograms.
 - 4) It is not the case that parallelograms are squares.

Geometry Multiple Choice Regents Exam Questions

www.jmap.org

- 402 Line segment AB is tangent to circle O at A . Which type of triangle is always formed when points A , B , and O are connected?
- 1) right
 - 2) obtuse
 - 3) scalene
 - 4) isosceles

- 403 In the diagram below, tangent \overline{PA} and secant \overline{PBC} are drawn to circle O from external point P .

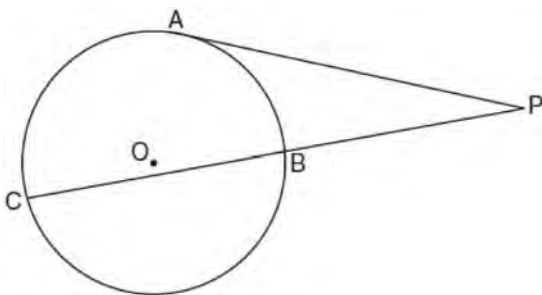

If $PB = 4$ and $BC = 5$, what is the length of \overline{PA} ?

- 1) 20
 - 2) 9
 - 3) 8
 - 4) 6
- 404 Two triangles are similar, and the ratio of each pair of corresponding sides is 2:1. Which statement regarding the two triangles is *not* true?
- 1) Their areas have a ratio of 4:1.
 - 2) Their altitudes have a ratio of 2:1.
 - 3) Their perimeters have a ratio of 2:1.
 - 4) Their corresponding angles have a ratio of 2:1.

- 405 The diagram below shows a pennant in the shape of an isosceles triangle. The equal sides each measure 13, the altitude is $x + 7$, and the base is $2x$.

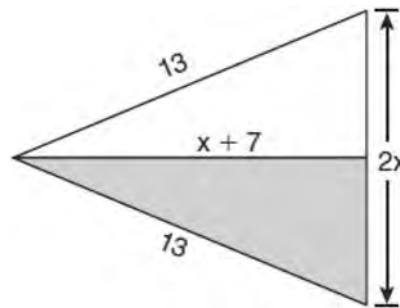

What is the length of the base?

- 1) 5
 - 2) 10
 - 3) 12
 - 4) 24
- 406 In the diagram below of trapezoid $RSUT$, $\overline{RS} \parallel \overline{TU}$, X is the midpoint of \overline{RT} , and V is the midpoint of \overline{SU} .

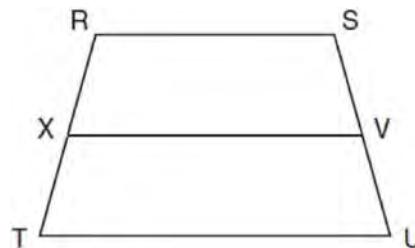

If $RS = 30$ and $XV = 44$, what is the length of \overline{TU} ?

- 1) 37
- 2) 58
- 3) 74
- 4) 118

Geometry Multiple Choice Regents Exam Questions

www.jmap.org

- 407 A support beam between the floor and ceiling of a house forms a 90° angle with the floor. The builder wants to make sure that the floor and ceiling are parallel. Which angle should the support beam form with the ceiling?
- 1) 45°
 - 2) 60°
 - 3) 90°
 - 4) 180°

- 408 If the surface area of a sphere is represented by 144π , what is the volume in terms of π ?
- 1) 36π
 - 2) 48π
 - 3) 216π
 - 4) 288π

- 409 In $\triangle ABC$, $\overline{AB} \cong \overline{BC}$. An altitude is drawn from B to \overline{AC} and intersects \overline{AC} at D . Which conclusion is *not* always true?
- 1) $\angle ABD \cong \angle CBD$
 - 2) $\angle BDA \cong \angle BDC$
 - 3) $\overline{AD} \cong \overline{BD}$
 - 4) $\overline{AD} \cong \overline{DC}$

- 410 In an equilateral triangle, what is the difference between the sum of the exterior angles and the sum of the interior angles?
- 1) 180°
 - 2) 120°
 - 3) 90°
 - 4) 60°

- 411 What is the measure of an interior angle of a regular octagon?
- 1) 45°
 - 2) 60°
 - 3) 120°
 - 4) 135°

- 412 What is the inverse of the statement “If two triangles are not similar, their corresponding angles are not congruent”?
- 1) If two triangles are similar, their corresponding angles are not congruent.
 - 2) If corresponding angles of two triangles are not congruent, the triangles are not similar.
 - 3) If two triangles are similar, their corresponding angles are congruent.
 - 4) If corresponding angles of two triangles are congruent, the triangles are similar.

- 413 In the diagram below of circle O , secant \overline{AB} intersects circle O at D , secant \overline{AOC} intersects circle O at E , $AE = 4$, $AB = 12$, and $DB = 6$.

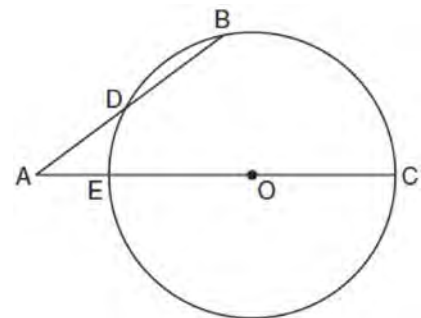

(Not drawn to scale)

What is the length of \overline{OC} ?

- 1) 4.5
- 2) 7
- 3) 9
- 4) 14

- 414 Which graph could be used to find the solution to the following system of equations?

$$y = -x + 2$$

$$y = x^2$$

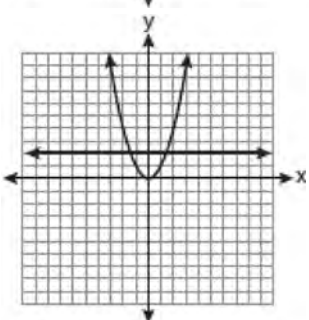
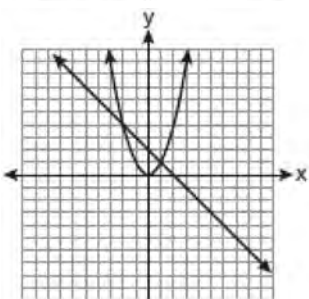
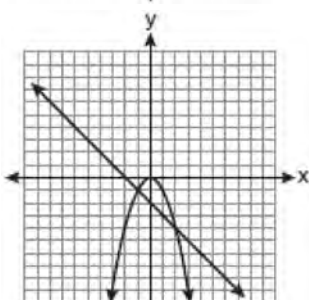
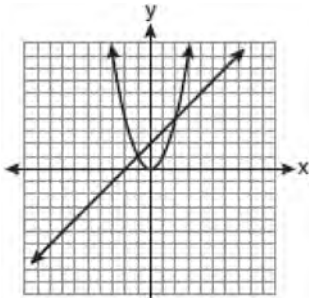

- 415 Point A is not contained in plane \mathcal{B} . How many lines can be drawn through point A that will be perpendicular to plane \mathcal{B} ?

- 1) one
- 2) two
- 3) zero
- 4) infinite

- 416 A polygon is transformed according to the rule: $(x, y) \rightarrow (x + 2, y)$. Every point of the polygon moves two units in which direction?

- 1) up
- 2) down
- 3) left
- 4) right

- 417 In the diagram below, \overline{PS} is a tangent to circle O at point S , \overline{PQR} is a secant, $PS = x$, $PQ = 3$, and $PR = x + 18$.

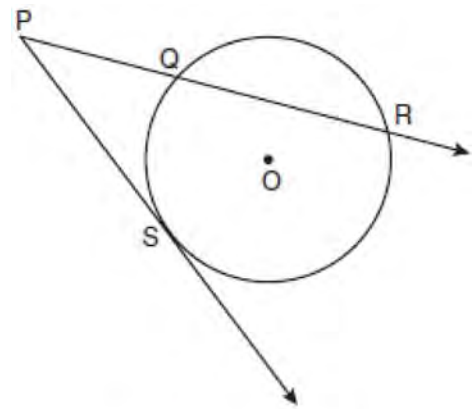

(Not drawn to scale)

What is the length of \overline{PS} ?

- 1) 6
- 2) 9
- 3) 3
- 4) 27

- 418 Given $\triangle ABC$ with base \overline{AFEDC} , median \overline{BF} , altitude \overline{BD} , and \overline{BE} bisects $\angle ABC$, which conclusion is valid?

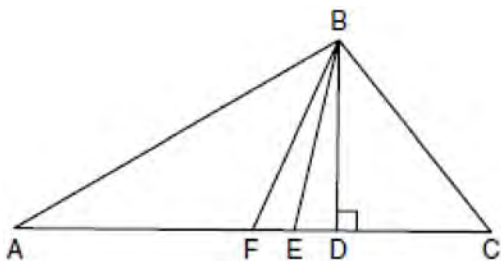

- 1) $\angle FAB \cong \angle ABF$
 - 2) $\angle ABF \cong \angle CBD$
 - 3) $\overline{CE} \cong \overline{EA}$
 - 4) $\overline{CF} \cong \overline{FA}$
- 419 In three-dimensional space, two planes are parallel and a third plane intersects both of the parallel planes. The intersection of the planes is a
- 1) plane
 - 2) point
 - 3) pair of parallel lines
 - 4) pair of intersecting lines
- 420 Which transformation of the line $x = 3$ results in an image that is perpendicular to the given line?
- 1) $r_{x\text{-axis}}$
 - 2) $r_{y\text{-axis}}$
 - 3) $r_{y = x}$
 - 4) $r_{x = 1}$

Geometry 2 Point Regents Exam Questions

- 421 In the diagram below of $\triangle ABC$, \overline{DE} is a midsegment of $\triangle ABC$, $DE = 7$, $AB = 10$, and $BC = 13$. Find the perimeter of $\triangle ABC$.

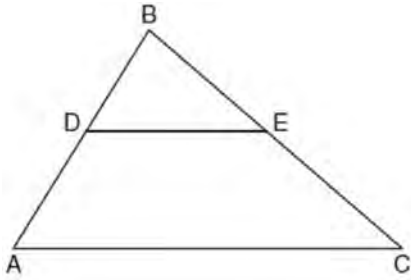

- 422 Triangle TAP has coordinates $T(-1, 4)$, $A(2, 4)$, and $P(2, 0)$. On the set of axes below, graph and label $\triangle T'A'P'$, the image of $\triangle TAP$ after the translation $(x, y) \rightarrow (x - 5, y - 1)$.

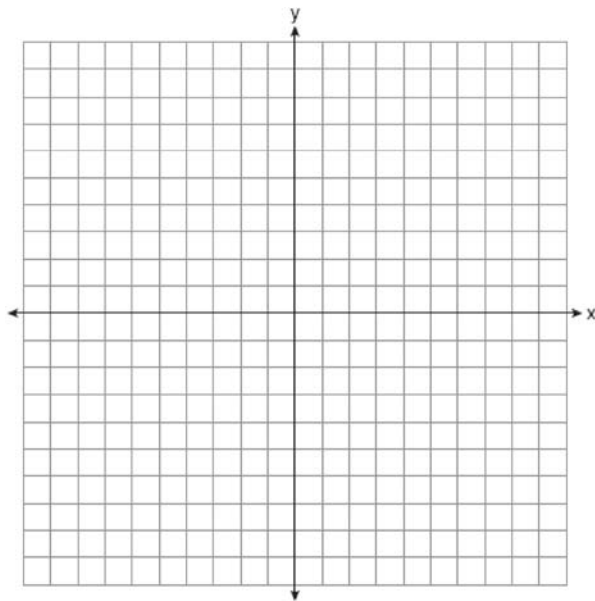

- 423 A right circular cone has a base with a radius of 15 cm, a vertical height of 20 cm, and a slant height of 25 cm. Find, in terms of π , the number of square centimeters in the lateral area of the cone.

- 424 Using a compass and straightedge, construct the angle bisector of $\angle ABC$ shown below. [Leave all construction marks.]

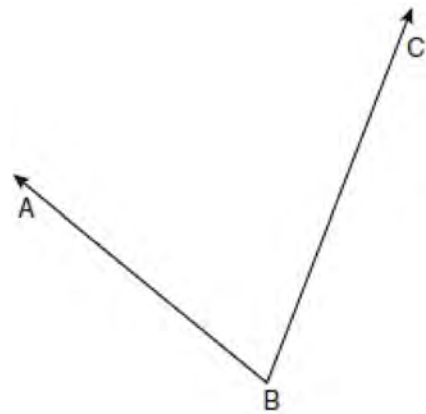

- 425 Using a compass and straightedge, construct a line that passes through point P and is perpendicular to line m . [Leave all construction marks.]

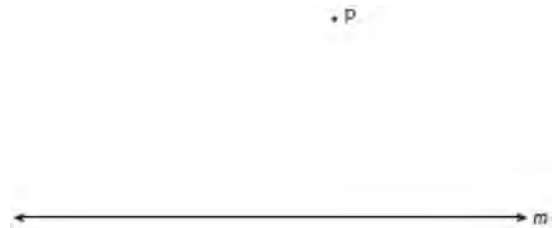

Geometry 2 Point Regents Exam Questions

www.jmap.org

426 Find the slope of a line perpendicular to the line whose equation is $2y - 6x = 4$.

427 Triangle ABC has vertices $A(3,3)$, $B(7,9)$, and $C(11,3)$. Determine the point of intersection of the medians, and state its coordinates. [The use of the set of axes below is optional.]

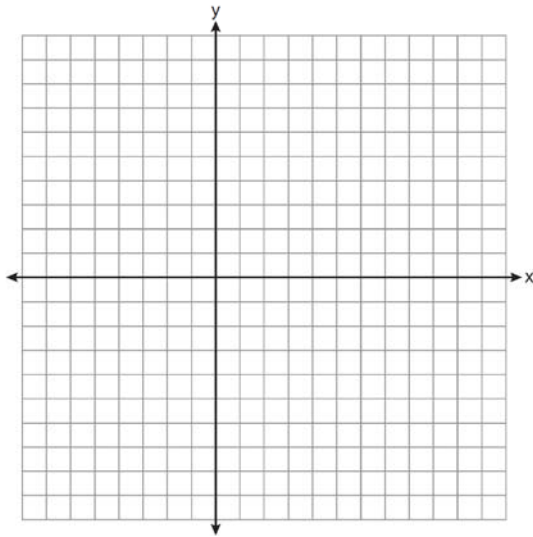

428 In the diagram below of circle O , chord \overline{AB} bisects chord \overline{CD} at E . If $AE = 8$ and $BE = 9$, find the length of \overline{CE} in simplest radical form.

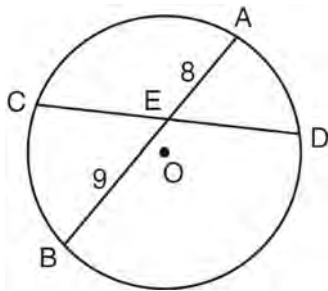

429 The graph below shows the locus of points equidistant from the x -axis and y -axis. On the same set of axes, graph the locus of points 3 units from the line $x = 0$. Label with an **X** all points that satisfy both conditions.

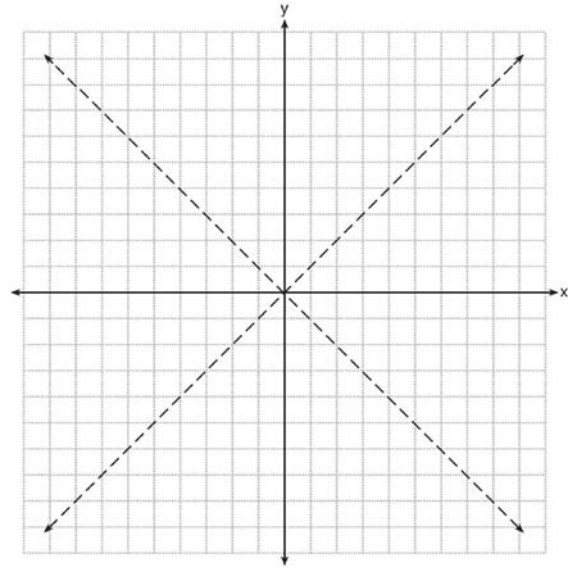

430 In the diagram below of $\triangle HQP$, side \overline{HP} is extended through P to T , $m\angle QPT = 6x + 20$, $m\angle HQP = x + 40$, and $m\angle PHQ = 4x - 5$. Find $m\angle QPT$.

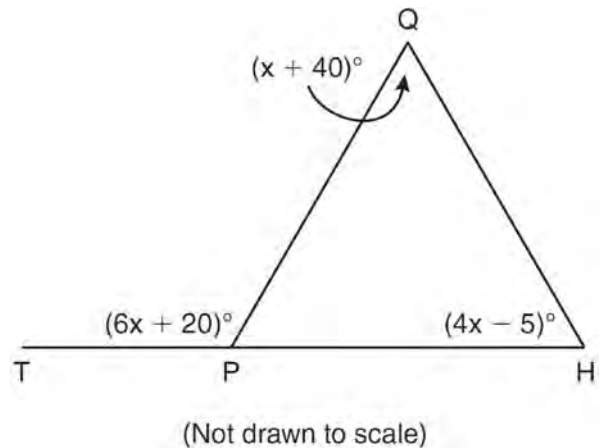

Geometry 2 Point Regents Exam Questions

www.jmap.org

431 Write an equation of a circle whose center is $(-3, 2)$ and whose diameter is 10.

432 A sphere has a diameter of 18 meters. Find the volume of the sphere, in cubic meters, in terms of π .

433 Tim is going to paint a wooden sphere that has a diameter of 12 inches. Find the surface area of the sphere, to the nearest square inch.

434 The base of a pyramid is a rectangle with a width of 6 cm and a length of 8 cm. Find, in centimeters, the height of the pyramid if the volume is 288 cm^3 .

435 In the diagram below, car A is parked 7 miles from car B . Sketch the points that are 4 miles from car A and sketch the points that are 4 miles from car B . Label with an **X** all points that satisfy both conditions.

Car A
•

Car B
•

436 Two lines, \overleftrightarrow{AB} and \overleftrightarrow{CRD} , are parallel and 10 inches apart. Sketch the locus of all points that are equidistant from \overleftrightarrow{AB} and \overleftrightarrow{CRD} and 7 inches from point R . Label with an **X** each point that satisfies both conditions.

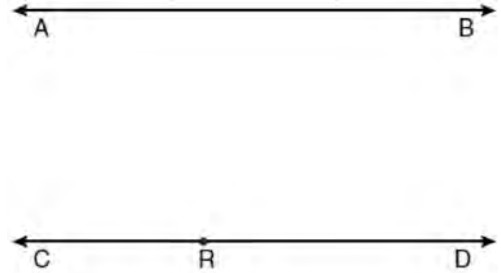

437 In the diagram below of $\triangle ACD$, B is a point on \overline{AC} such that $\triangle ADB$ is an equilateral triangle, and $\triangle DBC$ is an isosceles triangle with $\overline{DB} \cong \overline{BC}$. Find $m\angle C$.

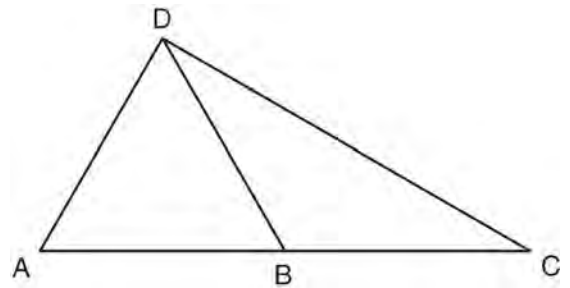

Geometry 2 Point Regents Exam Questions

www.jmap.org

- 438 Using a compass and straightedge, construct a line perpendicular to line ℓ through point P . [Leave all construction marks.]

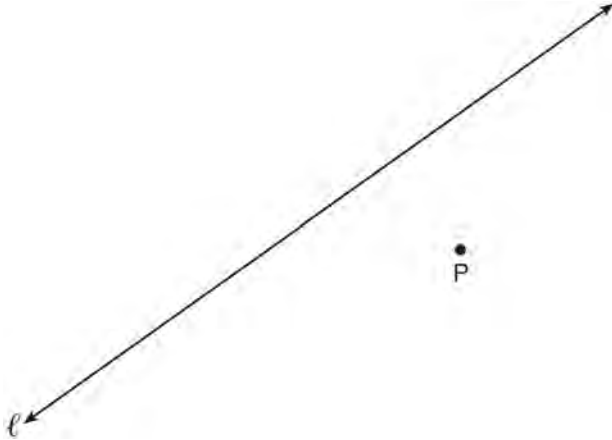

- 439 In the diagram below of $\triangle TEM$, medians \overline{TB} , \overline{EC} , and \overline{MA} intersect at D , and $TB = 9$. Find the length of TD .

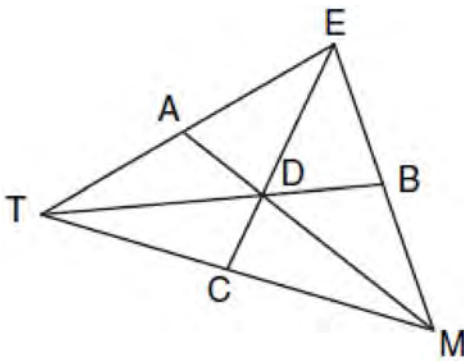

- 440 A circle has the equation $(x - 3)^2 + (y + 4)^2 = 10$. Find the coordinates of the center of the circle and the length of the circle's radius.

- 441 In the diagram below, two parallel lines intersect circle O at points $A, B, C,$ and D , with $m\widehat{AB} = x + 20$ and $m\widehat{DC} = 2x - 20$. Find $m\widehat{AB}$.

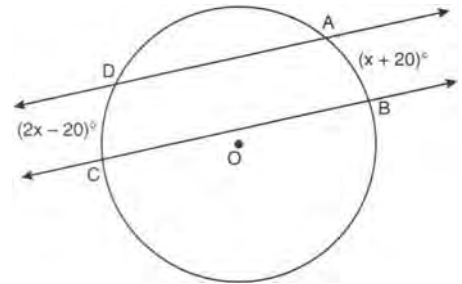

- 442 Using a compass and straightedge, construct the bisector of the angle shown below. [Leave all construction marks.]

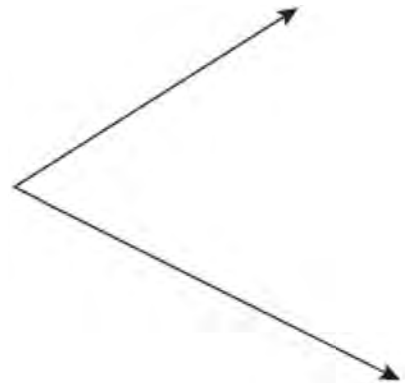

- 443 Write the negation of the statement “2 is a prime number,” and determine the truth value of the negation.

Geometry 2 Point Regents Exam Questions

www.jmap.org

- 444 On the set of axes below, graph the locus of points 4 units from the x -axis and equidistant from the points whose coordinates are $(-2, 0)$ and $(8, 0)$. Mark with an **X** all points that satisfy *both* conditions.

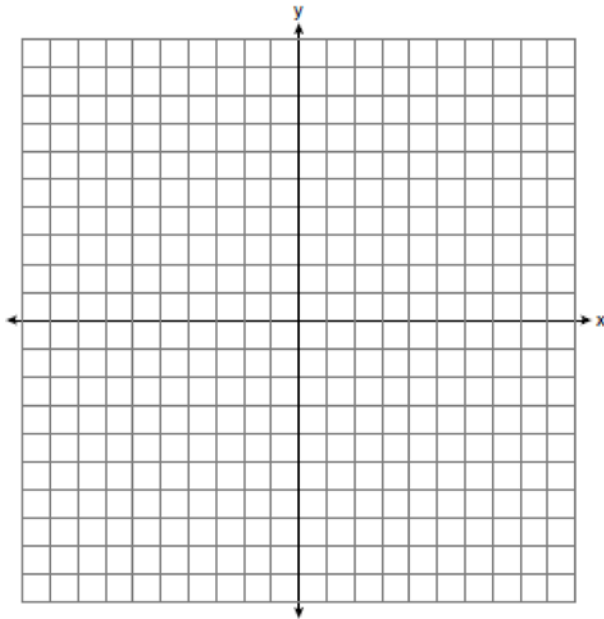

- 447 Write an equation of the circle graphed in the diagram below.

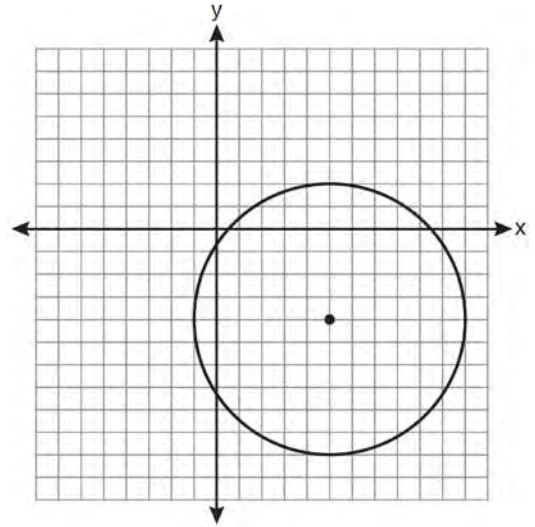

- 445 Two lines are represented by the equations $x + 2y = 4$ and $4y - 2x = 12$. Determine whether these lines are parallel, perpendicular, or neither. Justify your answer.

- 446 The Parkside Packing Company needs a rectangular shipping box. The box must have a length of 11 inches and a width of 8 inches. Find, to the *nearest tenth of an inch*, the minimum height of the box such that the volume is *at least* 800 cubic inches.

- 448 Using a compass and straightedge, construct a line perpendicular to \overline{AB} through point P . [Leave all construction marks.]

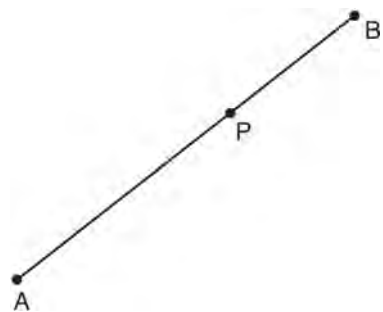

Geometry 2 Point Regents Exam Questions

www.jmap.org

449 Determine whether the two lines represented by the equations $y = 2x + 3$ and $2y + x = 6$ are parallel, perpendicular, or neither. Justify your response.

450 In the diagram below of $\triangle ACD$, E is a point on \overline{AD} and B is a point on \overline{AC} , such that $\overline{EB} \parallel \overline{DC}$. If $\overline{AE} = 3$, $\overline{ED} = 6$, and $\overline{DC} = 15$, find the length of \overline{EB} .

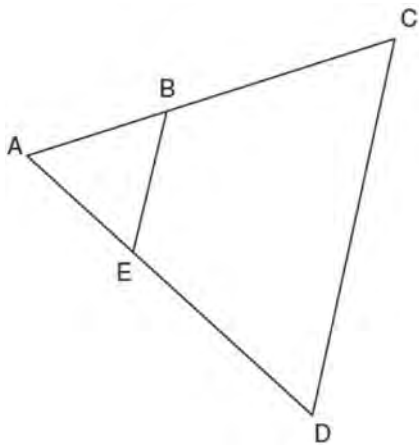

451 In the diagram below of circle O , diameter \overline{AB} is perpendicular to chord \overline{CD} at E . If $AO = 10$ and $BE = 4$, find the length of \overline{CE} .

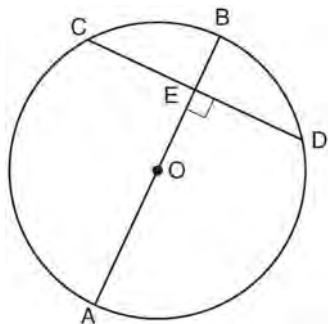

452 On the diagram of $\triangle ABC$ shown below, use a compass and straightedge to construct the perpendicular bisector of \overline{AC} . [Leave all construction marks.]

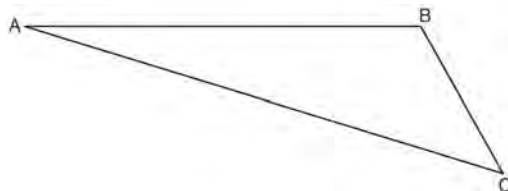

453 Write an equation for circle O shown on the graph below.

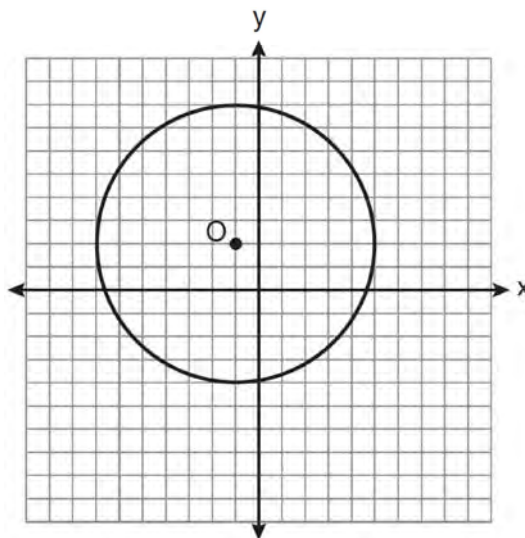

Geometry 2 Point Regents Exam Questions

www.jmap.org

- 454 The vertices of $\triangle ABC$ are $A(3, 2)$, $B(6, 1)$, and $C(4, 6)$. Identify and graph a transformation of $\triangle ABC$ such that its image, $\triangle A'B'C'$, results in $\overline{AB} \parallel \overline{A'B'}$.

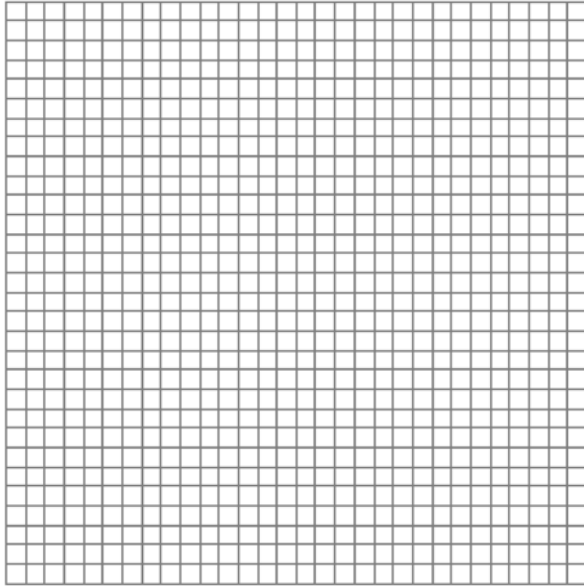

- 457 On the set of axes below, graph the locus of points 4 units from $(0, 1)$ and the locus of points 3 units from the origin. Label with an **X** any points that satisfy *both* conditions.

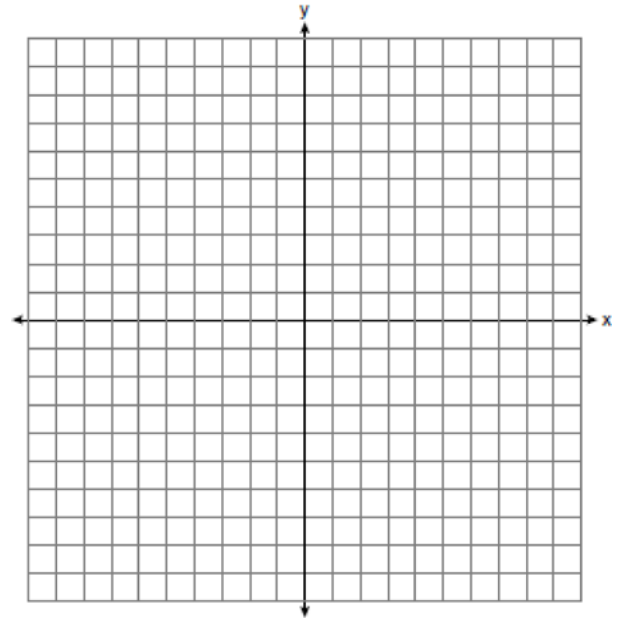

- 455 In the diagram of $\triangle ABC$ below, $AB = 10$, $BC = 14$, and $AC = 16$. Find the perimeter of the triangle formed by connecting the midpoints of the sides of $\triangle ABC$.

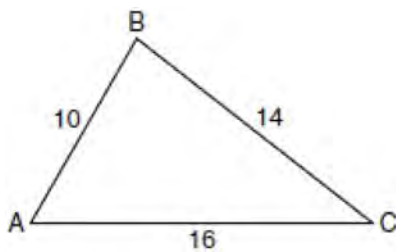

- 458 In the diagram below of $\triangle ABC$, D is a point on \overline{AB} , E is a point on \overline{BC} , $\overline{AC} \parallel \overline{DE}$, $CE = 25$ inches, $AD = 18$ inches, and $DB = 12$ inches. Find, to the nearest tenth of an inch, the length of \overline{EB} .

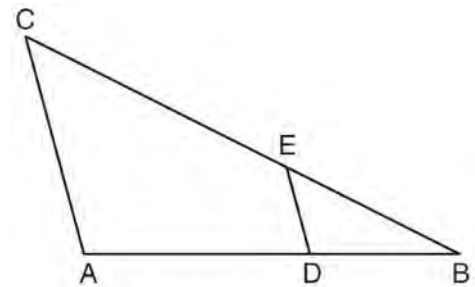

- 456 The coordinates of two vertices of square $ABCD$ are $A(2, 1)$ and $B(4, 4)$. Determine the slope of side \overline{BC} .

Geometry 2 Point Regents Exam Questions

www.jmap.org

459 The endpoints of \overline{PQ} are $P(-3, 1)$ and $Q(4, 25)$.
Find the length of \overline{PQ} .

460 On the ray drawn below, using a compass and straightedge, construct an equilateral triangle with a vertex at R . The length of a side of the triangle must be equal to a length of the diagonal of rectangle $ABCD$.



461 Given the true statement, "The medians of a triangle are concurrent," write the negation of the statement and give the truth value for the negation.

462 In $\triangle RST$, $m\angle RST = 46$ and $\overline{RS} \cong \overline{ST}$. Find $m\angle STR$.

463 In the diagram below, $\ell \parallel m$ and $\overline{QR} \perp \overline{ST}$ at R .

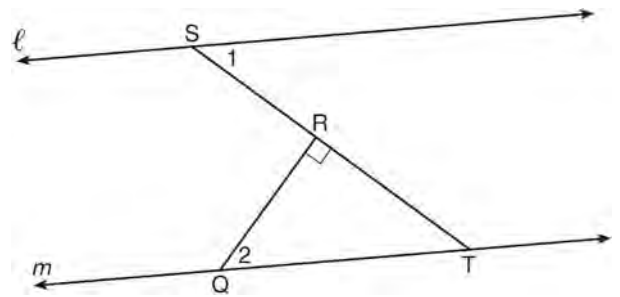

If $m\angle 1 = 63$, find $m\angle 2$.

464 In the diagram below, circles A and B are tangent at point C and \overline{AB} is drawn. Sketch all common tangent lines.

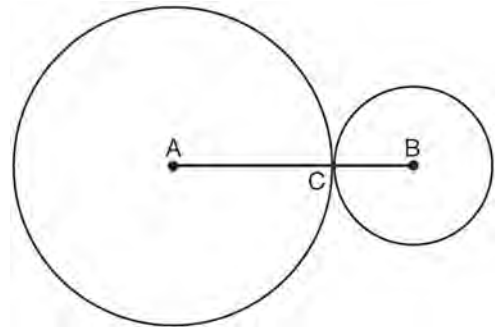

465 A right circular cylinder has a height of 7 inches and the base has a diameter of 6 inches. Determine the lateral area, in square inches, of the cylinder in terms of π .

Geometry 2 Point Regents Exam Questions

www.jmap.org

- 466 In the diagram below, point M is located on \overleftrightarrow{AB} .
 Sketch the locus of points that are 1 unit from \overleftrightarrow{AB} and the locus of points 2 units from point M . Label with an **X** all points that satisfy both conditions.

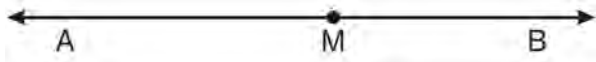

- 467 On the line segment below, use a compass and straightedge to construct equilateral triangle ABC .
 [Leave all construction marks.]



- 468 On the set of axes below, graph the locus of points that are 4 units from the line $x = 3$ and the locus of points that are 5 units from the point $(0, 2)$. Label with an **X** all points that satisfy both conditions.

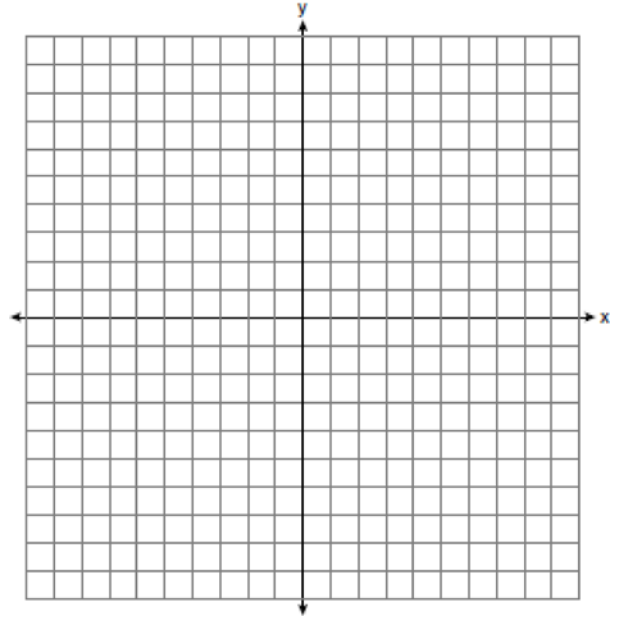

- 469 A cylinder has a height of 7 cm and a base with a diameter of 10 cm. Determine the volume, in cubic centimeters, of the cylinder in terms of π .
- 470 Write an equation of the line that passes through the point $(6, -5)$ and is parallel to the line whose equation is $2x - 3y = 11$.

Geometry 2 Point Regents Exam Questions

www.jmap.org

- 471 Triangle ABC has vertices $A(-2, 2)$, $B(-1, -3)$, and $C(4, 0)$. Find the coordinates of the vertices of $\triangle A'B'C'$, the image of $\triangle ABC$ after the transformation $r_{x\text{-axis}}$. [The use of the grid is optional.]

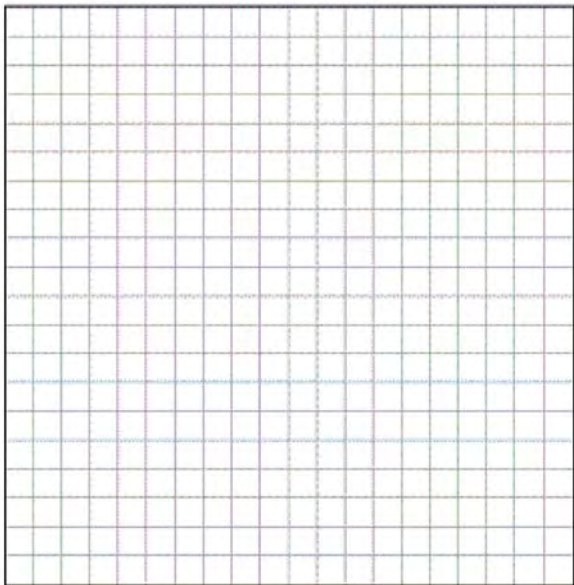

- 472 Tim has a rectangular prism with a length of 10 centimeters, a width of 2 centimeters, and an unknown height. He needs to build another rectangular prism with a length of 5 centimeters and the same height as the original prism. The volume of the two prisms will be the same. Find the width, in centimeters, of the new prism.

- 473 Triangle ABC has vertices $A(6, 6)$, $B(9, 0)$, and $C(3, -3)$. State and label the coordinates of $\triangle A'B'C'$, the image of $\triangle ABC$ after a dilation of $D\frac{1}{3}$.

- 474 On the diagram below, use a compass and straightedge to construct the bisector of $\angle XYZ$. [Leave all construction marks.]

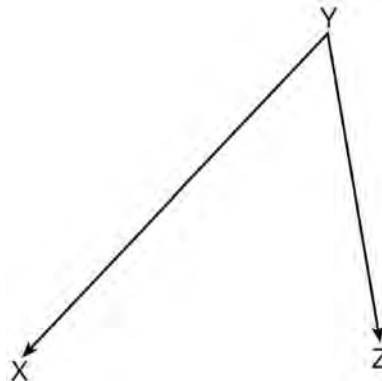

- 475 Write an equation of the line that is the perpendicular bisector of the line segment having endpoints $(3, -1)$ and $(3, 5)$. [The use of the grid below is optional]

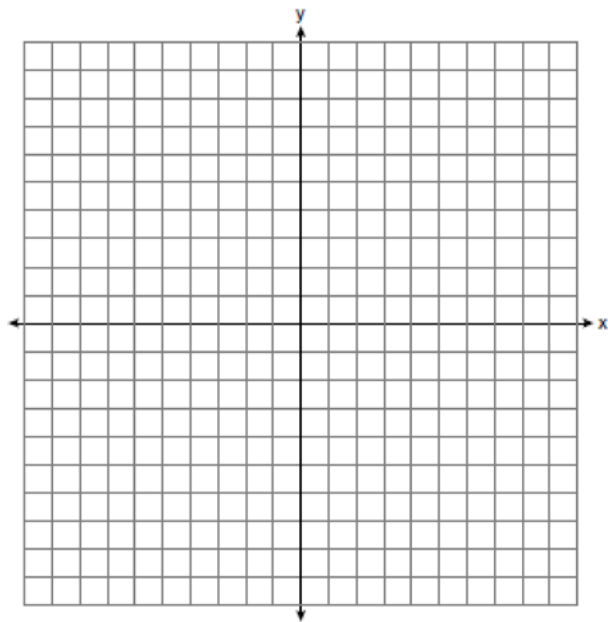

Geometry 2 Point Regents Exam Questions

www.jmap.org

476 Triangle ABC has vertices at $A(3, 0)$, $B(9, -5)$, and $C(7, -8)$. Find the length of \overline{AC} in simplest radical form.

477 Using a compass and straightedge, construct the bisector of $\angle MJH$. [Leave all construction marks.]

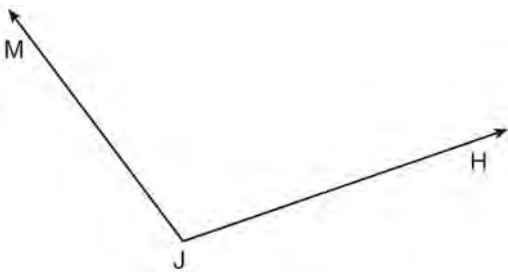

478 A regular pyramid with a square base is shown in the diagram below.

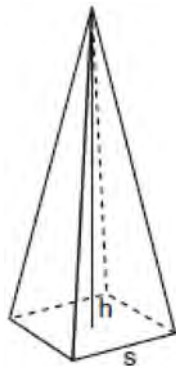

A side, s , of the base of the pyramid is 12 meters, and the height, h , is 42 meters. What is the volume of the pyramid in cubic meters?

479 Find an equation of the line passing through the point $(5, 4)$ and parallel to the line whose equation is $2x + y = 3$.

480 Find, in simplest radical form, the length of the line segment with endpoints whose coordinates are $(-1, 4)$ and $(3, -2)$.

481 The coordinates of the endpoints of \overline{FG} are $(-4, 3)$ and $(2, 5)$. Find the length of \overline{FG} in simplest radical form.

482 After the transformation $r_{y=x}$ the image of $\triangle ABC$ is $\triangle A'B'C'$. If $AB = 2x + 13$ and $A'B' = 9x - 8$, find the value of x .

483 In the diagram below of right triangle ACB , altitude \overline{CD} intersects \overline{AB} at D . If $AD = 3$ and $DB = 4$, find the length of \overline{CD} in simplest radical form.

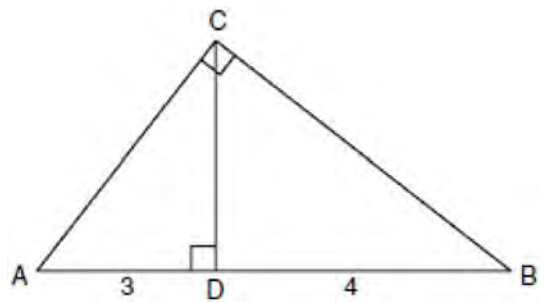

Geometry 2 Point Regents Exam Questions

www.jmap.org

- 484 The diagram below shows $\triangle ABC$, with \overline{AEB} , \overline{ADC} , and $\angle ACB \cong \angle AED$. Prove that $\triangle ABC$ is similar to $\triangle ADE$.

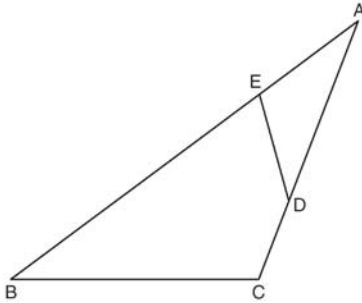

- 485 Using a compass and straightedge, on the diagram below of \overleftrightarrow{RS} , construct an equilateral triangle with \overline{RS} as one side. [Leave all construction marks.]



- 486 The coordinates of the vertices of $\triangle RST$ are $R(-2, 3)$, $S(4, 4)$, and $T(2, -2)$. Triangle $R'S'T'$ is the image of $\triangle RST$ after a rotation of 90° about the origin. State the coordinates of the vertices of $\triangle R'S'T'$. [The use of the set of axes below is optional.]

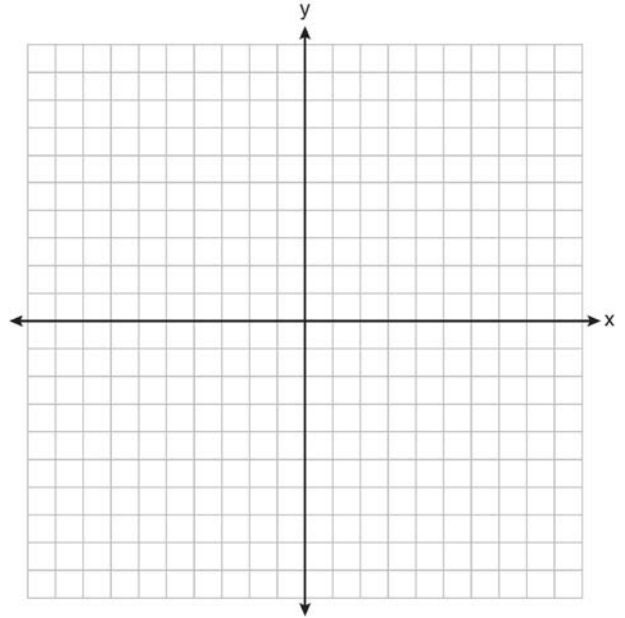

- 487 Using a compass and straightedge, and \overline{AB} below, construct an equilateral triangle with all sides congruent to \overline{AB} . [Leave all construction marks.]



Geometry 2 Point Regents Exam Questions

www.jmap.org

- 488 Triangle XYZ , shown in the diagram below, is reflected over the line $x = 2$. State the coordinates of $\triangle X'Y'Z'$, the image of $\triangle XYZ$.

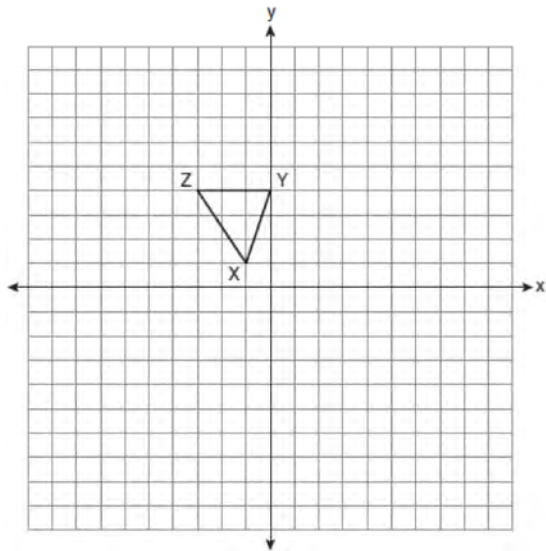

- 490 Two intersecting lines are shown in the diagram below. Sketch the locus of points that are equidistant from the two lines. Sketch the locus of points that are a given distance, d , from the point of intersection of the given lines. State the number of points that satisfy both conditions.

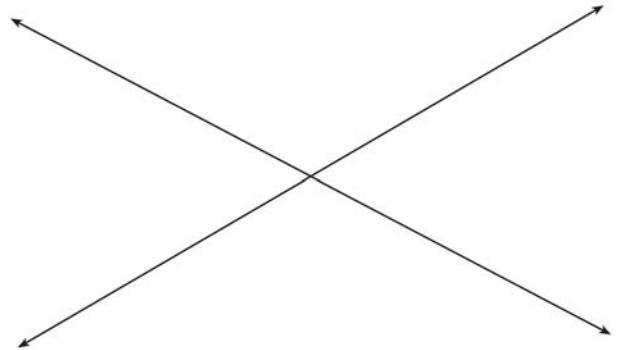

- 489 In the diagram below of isosceles trapezoid $DEFG$, $\overline{DE} \parallel \overline{GF}$, $DE = 4x - 2$, $EF = 3x + 2$, $FG = 5x - 3$, and $GD = 2x + 5$. Find the value of x .

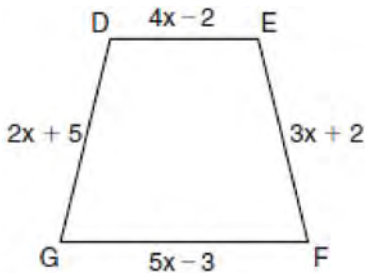

- 491 Given: Two is an even integer or three is an even integer.
Determine the truth value of this disjunction.
Justify your answer.

- 492 The diagram below shows isosceles trapezoid $ABCD$ with $\overline{AB} \parallel \overline{DC}$ and $\overline{AD} \cong \overline{BC}$. If $m\angle BAD = 2x$ and $m\angle BCD = 3x + 5$, find $m\angle BAD$.

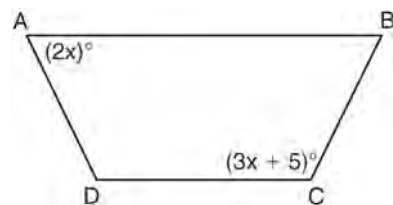

Geometry 2 Point Regents Exam Questions

www.jmap.org

- 493 On the diagram below, use a compass and straightedge to construct the bisector of $\angle ABC$. [Leave all construction marks.]

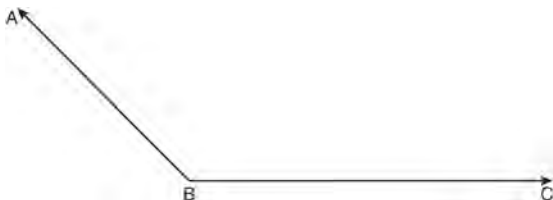

- 494 In the diagram below, trapezoid $ABCD$, with bases \overline{AB} and \overline{DC} , is inscribed in circle O , with diameter \overline{DC} . If $m\widehat{AB} = 80$, find $m\widehat{BC}$.

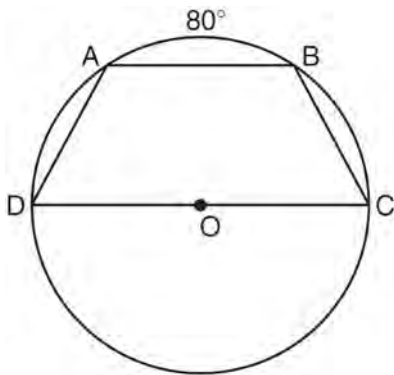

- 495 Write a statement that is logically equivalent to the statement “If two sides of a triangle are congruent, the angles opposite those sides are congruent.” Identify the new statement as the converse, inverse, or contrapositive of the original statement.

- 496 In circle O , diameter \overline{RS} has endpoints $R(3a, 2b - 1)$ and $S(a - 6, 4b + 5)$. Find the coordinates of point O , in terms of a and b . Express your answer in simplest form.

- 497 In $\triangle ABC$, the measure of angle A is fifteen less than twice the measure of angle B . The measure of angle C equals the sum of the measures of angle A and angle B . Determine the measure of angle B .

- 498 In right $\triangle DEF$, $m\angle D = 90$ and $m\angle F$ is 12 degrees less than twice $m\angle E$. Find $m\angle E$.

- 499 A pentagon is drawn on the set of axes below. If the pentagon is reflected over the y -axis, determine if this transformation is an isometry. Justify your answer. [The use of the set of axes is optional.]

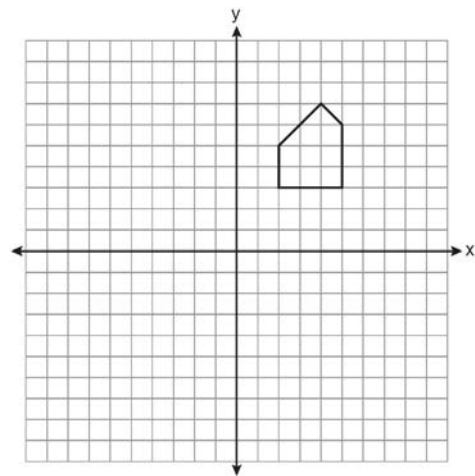

- 500 Find, in degrees, the measures of both an interior angle and an exterior angle of a regular pentagon.

Geometry 2 Point Regents Exam Questions

www.jmap.org

- 501 The cylindrical tank shown in the diagram below is to be painted. The tank is open at the top, and the bottom does *not* need to be painted. Only the outside needs to be painted. Each can of paint covers 600 square feet. How many cans of paint must be purchased to complete the job?

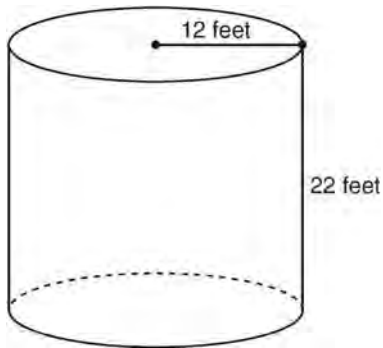

- 502 In the diagram below of circle C , \overline{QR} is a diameter, and $Q(1, 8)$ and $C(3.5, 2)$ are points on a coordinate plane. Find and state the coordinates of point R .

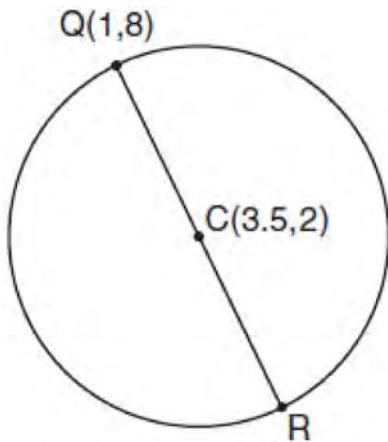

- 503 The volume of a cylinder is $12,566.4 \text{ cm}^3$. The height of the cylinder is 8 cm. Find the radius of the cylinder to the *nearest tenth of a centimeter*.

- 504 In the diagram below, $\triangle ABC \sim \triangle EFG$, $m\angle C = 4x + 30$, and $m\angle G = 5x + 10$. Determine the value of x .

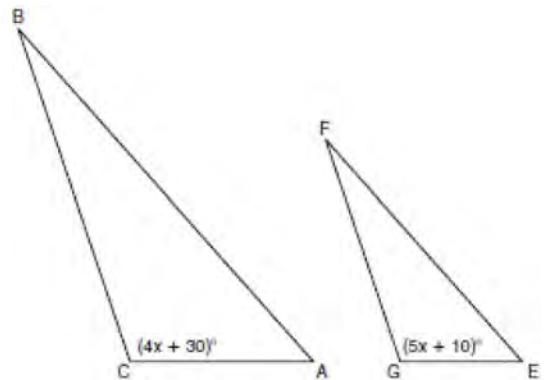

- 505 The coordinates of the vertices of $\triangle ABC$ are $A(1, 2)$, $B(-4, 3)$, and $C(-3, -5)$. State the coordinates of $\triangle A'B'C'$, the image of $\triangle ABC$ after a rotation of 90° about the origin. [The use of the set of axes below is optional.]

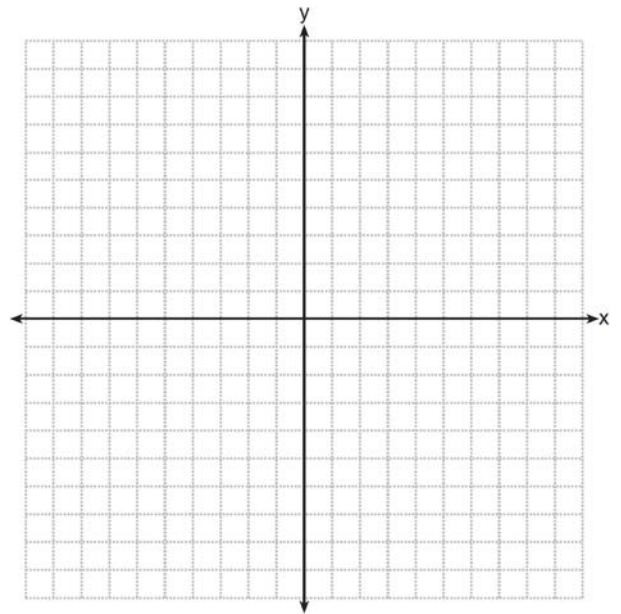

Geometry 2 Point Regents Exam Questions

www.jmap.org

- 506 In the diagram below of $\triangle ABC$ with side \overline{AC} extended through D , $m\angle A = 37$ and $m\angle BCD = 117$. Which side of $\triangle ABC$ is the longest side? Justify your answer.

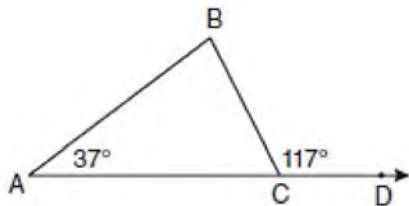

(Not drawn to scale)

- 507 The degree measures of the angles of $\triangle ABC$ are represented by x , $3x$, and $5x - 54$. Find the value of x .

- 510 The length of \overline{AB} is 3 inches. On the diagram below, sketch the points that are equidistant from A and B and sketch the points that are 2 inches from A . Label with an **X** all points that satisfy both conditions.



- 508 Determine, in degrees, the measure of each interior angle of a regular octagon.

- 509 Using a compass and straightedge, construct the bisector of $\angle CBA$. [Leave all construction marks.]

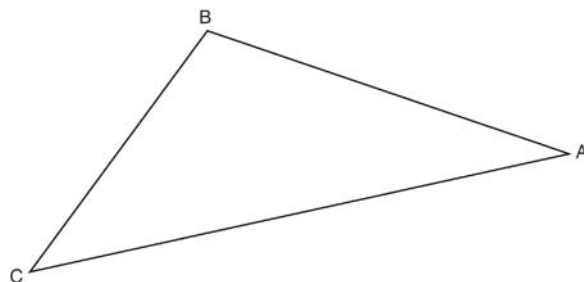

Geometry 4 Point Regents Exam Questions

- 511 In circle O shown below, chords \overline{AB} and \overline{CD} and radius \overline{OA} are drawn, such that $\overline{AB} \cong \overline{CD}$, $\overline{OE} \perp \overline{AB}$, $\overline{OF} \perp \overline{CD}$, $OF = 16$, $CF = y + 10$, and $CD = 4y - 20$.

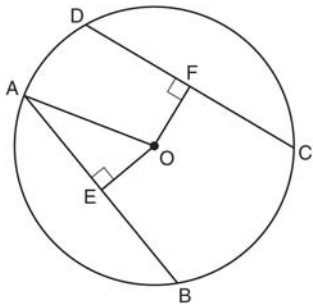

Determine the length of \overline{DF} . Determine the length of \overline{OA} .

- 512 Solve the following system of equations graphically.

$$2x^2 - 4x = y + 1$$

$$x + y = 1$$

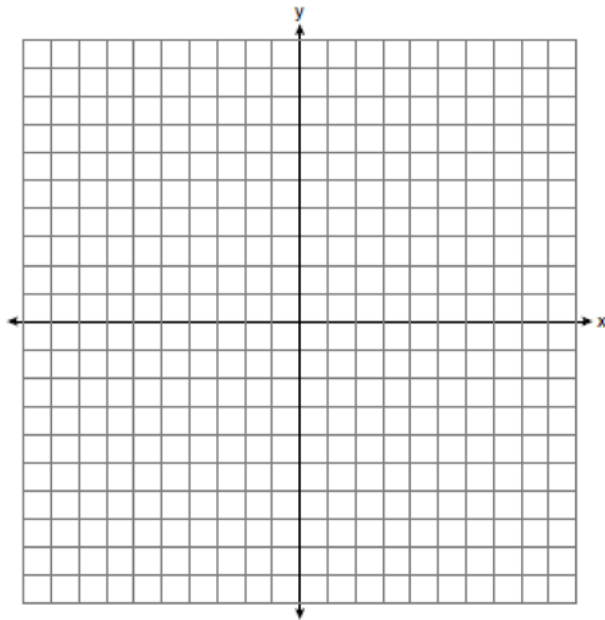

- 513 On the set of axes below, solve the following system of equations graphically and state the coordinates of *all* points in the solution.

$$(x + 3)^2 + (y - 2)^2 = 25$$

$$2y + 4 = -x$$

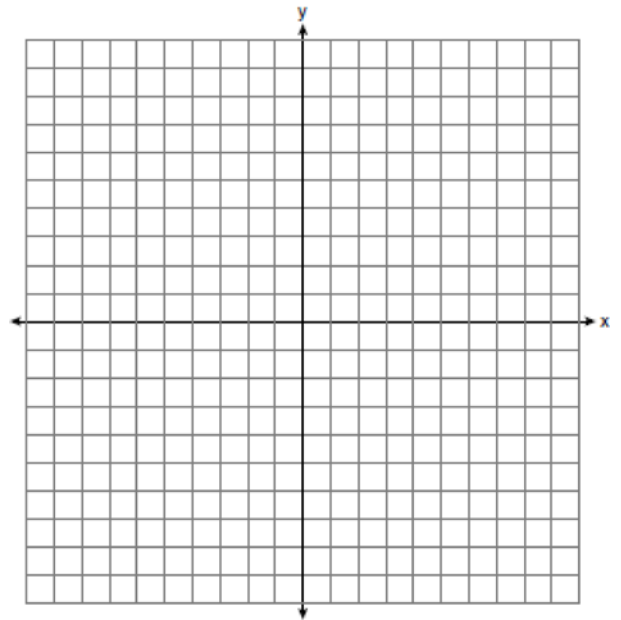

- 514 In the diagram below, $\triangle ABC \sim \triangle DEF$, $DE = 4$, $AB = x$, $AC = x + 2$, and $DF = x + 6$. Determine the length of AB . [Only an algebraic solution can receive full credit.]

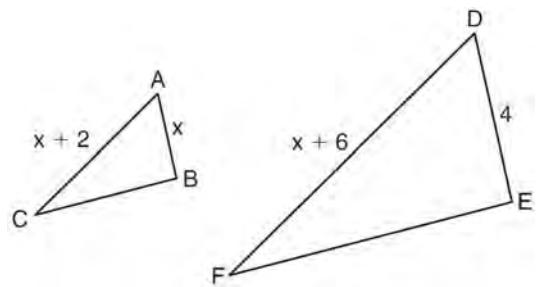

Geometry 4 Point Regents Exam Questions

www.jmap.org

- 515 Triangle ABC has vertices $A(5, 1)$, $B(1, 4)$ and $C(1, 1)$. State and label the coordinates of the vertices of $\triangle A''B''C''$, the image of $\triangle ABC$, following the composite transformation $T_{1,-1} \circ D_2$.
[The use of the set of axes below is optional.]

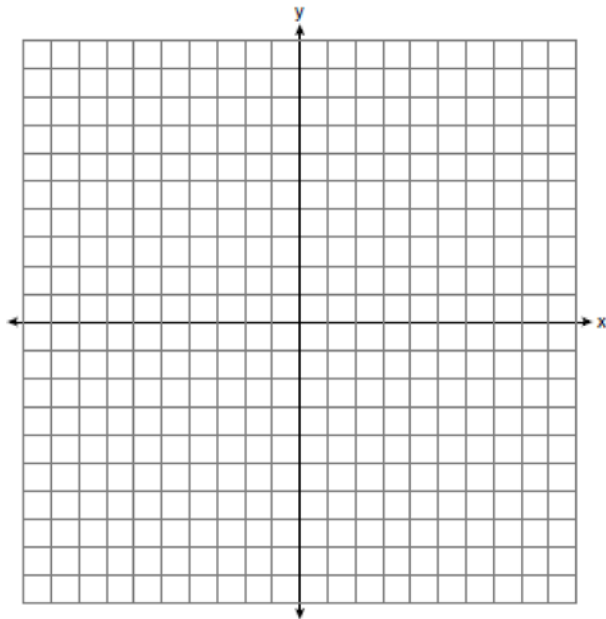

- 516 In the diagram below of circle O , chords \overline{DF} , \overline{DE} , \overline{FG} , and \overline{EG} are drawn such that $m\widehat{DF} : m\widehat{FE} : m\widehat{EG} : m\widehat{GD} = 5 : 2 : 1 : 7$. Identify one pair of inscribed angles that are congruent to each other and give their measure.

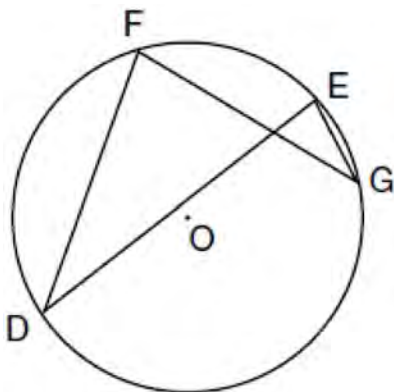

- 517 Triangle ABC has coordinates $A(-6, 2)$, $B(-3, 6)$, and $C(5, 0)$. Find the perimeter of the triangle. Express your answer in simplest radical form. [The use of the grid below is optional.]

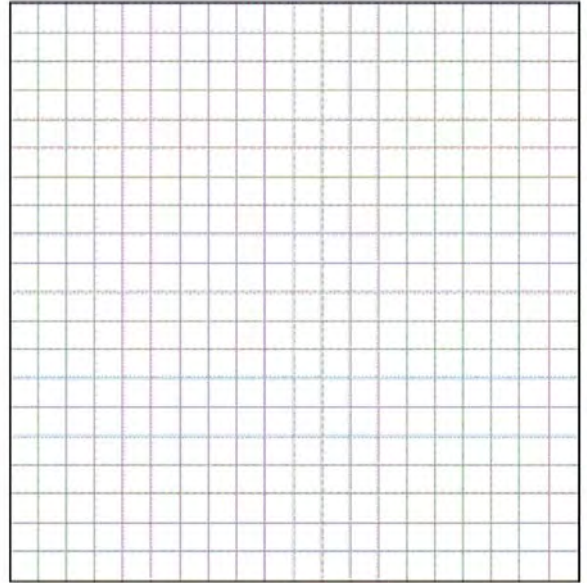

- 518 In the diagram below of quadrilateral $ABCD$ with diagonal \overline{BD} , $m\angle A = 93$, $m\angle ADB = 43$, $m\angle C = 3x + 5$, $m\angle BDC = x + 19$, and $m\angle DBC = 2x + 6$. Determine if \overline{AB} is parallel to \overline{DC} . Explain your reasoning.

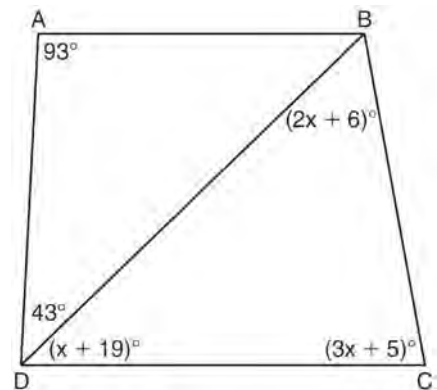

Geometry 4 Point Regents Exam Questions

www.jmap.org

- 519 The coordinates of the vertices of parallelogram $ABCD$ are $A(-2, 2)$, $B(3, 5)$, $C(4, 2)$, and $D(-1, -1)$. State the coordinates of the vertices of parallelogram $A''B''C''D''$ that result from the transformation $r_{y\text{-axis}} \circ T_{2, -3}$. [The use of the set of axes below is optional.]

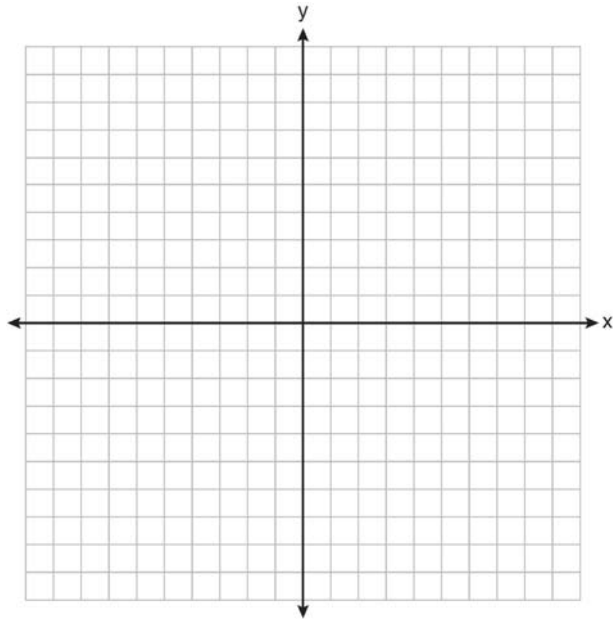

- 520 In the diagram below, $\triangle RST$ is a 3-4-5 right triangle. The altitude, h , to the hypotenuse has been drawn. Determine the length of h .

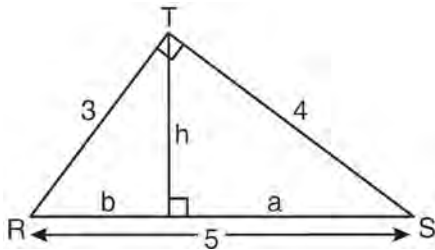

- 521 Write an equation of the circle whose diameter \overline{AB} has endpoints $A(-4, 2)$ and $B(4, -4)$. [The use of the grid below is optional.]

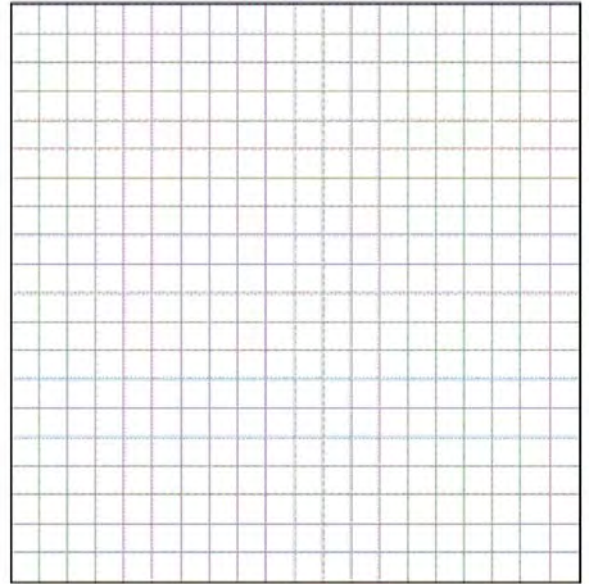

- 522 In the diagram below of $\triangle GJK$, H is a point on \overline{GJ} , $\overline{HJ} \cong \overline{JK}$, $m\angle G = 28$, and $m\angle GJK = 70$. Determine whether $\triangle GHK$ is an isosceles triangle and justify your answer.

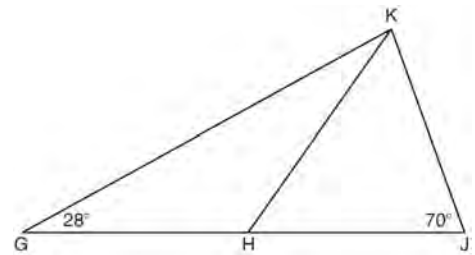

Geometry 4 Point Regents Exam Questions

www.jmap.org

- 523 As shown on the set of axes below, $\triangle GHS$ has vertices $G(3, 1)$, $H(5, 3)$, and $S(1, 4)$. Graph and state the coordinates of $\triangle G''H''S''$, the image of $\triangle GHS$ after the transformation $T_{-3,1} \circ D_2$.

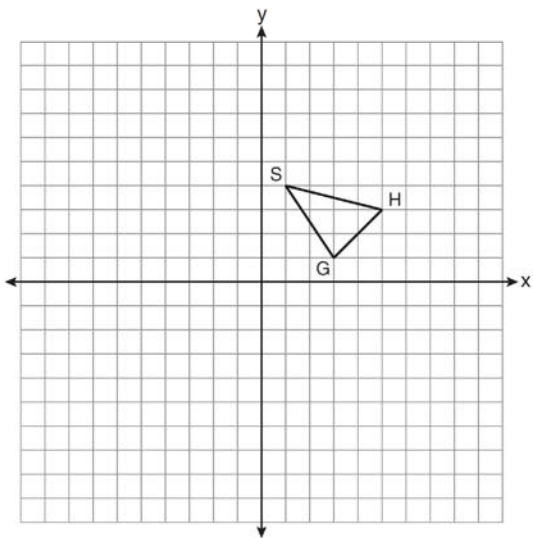

- 524 Given: Quadrilateral $ABCD$ with $\overline{AB} \cong \overline{CD}$, $\overline{AD} \cong \overline{BC}$, and diagonal \overline{BD} is drawn
Prove: $\angle BDC \cong \angle ABD$

- 525 As shown in the diagram below, the diagonals of parallelogram $QRST$ intersect at E . If $QE = x^2 + 6x$, $SE = x + 14$, and $TE = 6x - 1$, determine TE algebraically.

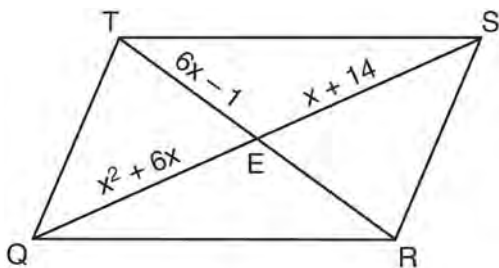

- 526 A paint can is in the shape of a right circular cylinder. The volume of the paint can is 600π cubic inches and its altitude is 12 inches. Find the radius, in inches, of the base of the paint can. Express the answer in simplest radical form. Find, to the nearest tenth of a square inch, the lateral area of the paint can.
- 527 On the set of axes below, graph the locus of points that are four units from the point $(2, 1)$. On the same set of axes, graph the locus of points that are two units from the line $x = 4$. State the coordinates of all points that satisfy both conditions.

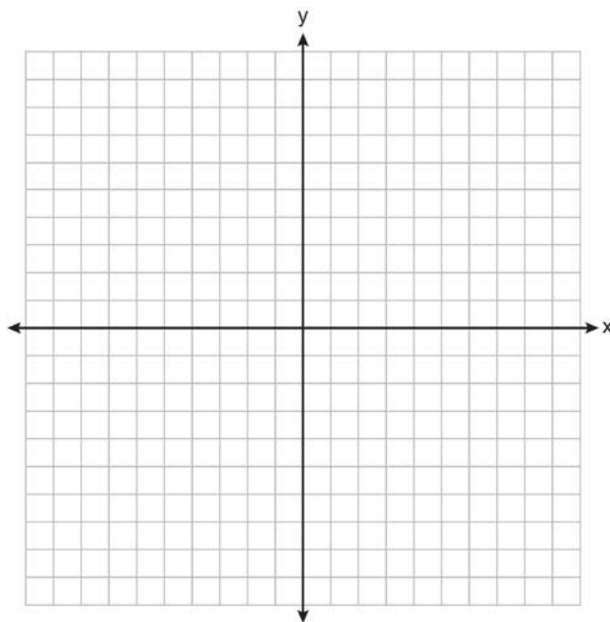

- 528 Find an equation of the line passing through the point $(6, 5)$ and perpendicular to the line whose equation is $2y + 3x = 6$.

Geometry 4 Point Regents Exam Questions

www.jmap.org

- 529 Triangle DEG has the coordinates $D(1, 1)$, $E(5, 1)$, and $G(5, 4)$. Triangle DEG is rotated 90° about the origin to form $\triangle D'E'G'$. On the grid below, graph and label $\triangle DEG$ and $\triangle D'E'G'$. State the coordinates of the vertices D' , E' , and G' . Justify that this transformation preserves distance.

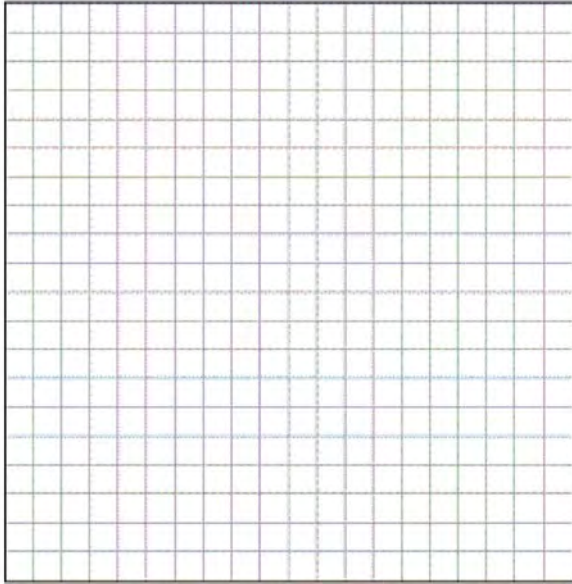

- 531 On the set of axes below, graph and label $\triangle DEF$ with vertices at $D(-4, -4)$, $E(-2, 2)$, and $F(8, -2)$. If \overline{G} is the midpoint of \overline{EF} and H is the midpoint of \overline{DF} , state the coordinates of G and H and label \overline{GH} . Explain why $\overline{GH} \parallel \overline{DE}$.

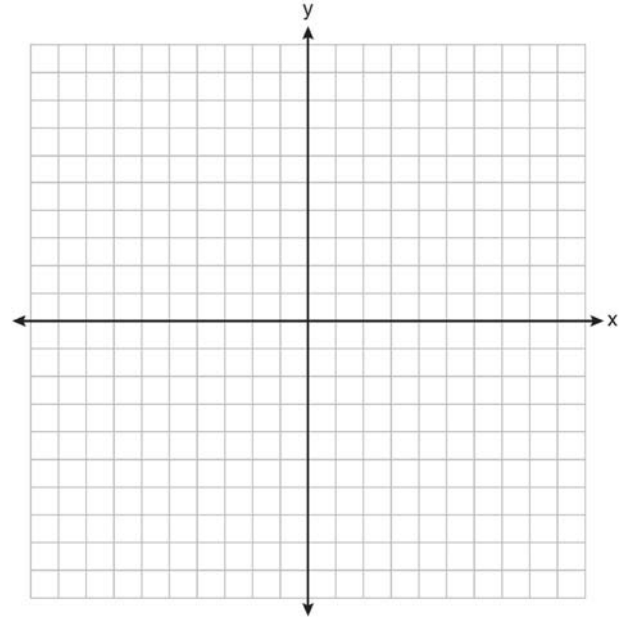

- 530 Trapezoid $TRAP$, with median \overline{MQ} , is shown in the diagram below. Solve algebraically for x and y .

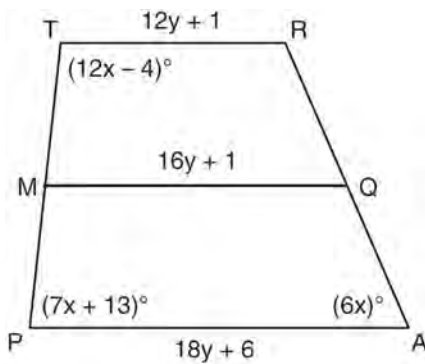

- 532 Given: \overline{JKLM} is a parallelogram.

$$\overline{JM} \cong \overline{LN}$$

$$\angle LMN \cong \angle LNM$$

Prove: \overline{JKLM} is a rhombus.

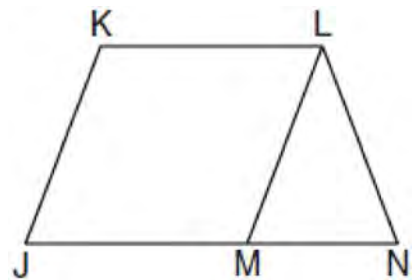

Geometry 4 Point Regents Exam Questions

www.jmap.org

- 533 On the grid below, graph the points that are equidistant from both the x and y axes and the points that are 5 units from the origin. Label with an **X** all points that satisfy *both* conditions.

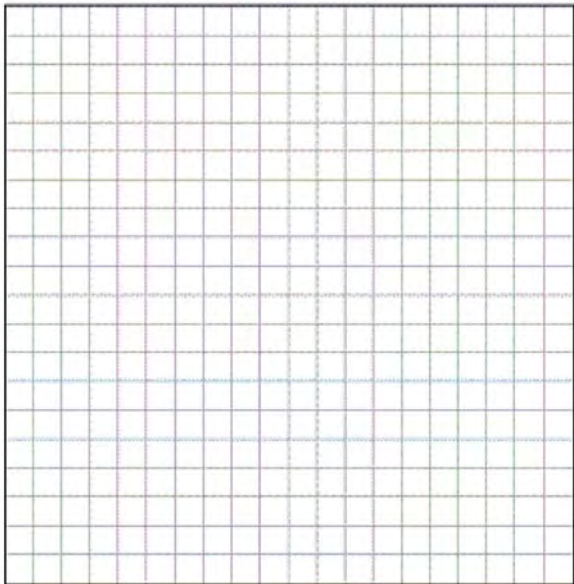

- 534 If $\triangle RST \sim \triangle ABC$, $m\angle A = x^2 - 8x$, $m\angle C = 4x - 5$, and $m\angle R = 5x + 30$, find $m\angle C$. [Only an algebraic solution can receive full credit.]

- 535 In the diagram below, circles X and Y have two tangents drawn to them from external point T . The points of tangency are C , A , S , and E . The ratio of \overline{TA} to \overline{AC} is 1:3. If $TS = 24$, find the length of \overline{SE} .

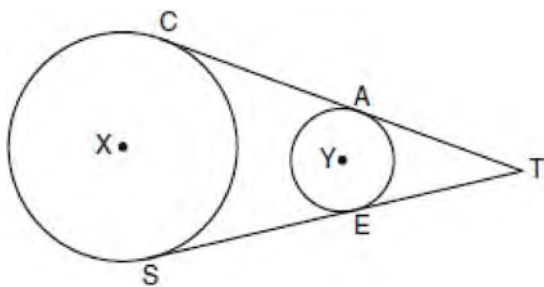

(Not drawn to scale)

- 536 A city is planning to build a new park. The park must be equidistant from school A at $(3, 3)$ and school B at $(3, -5)$. The park also must be exactly 5 miles from the center of town, which is located at the origin on the coordinate graph. Each unit on the graph represents 1 mile. On the set of axes below, sketch the compound loci and label with an **X** all possible locations for the new park.

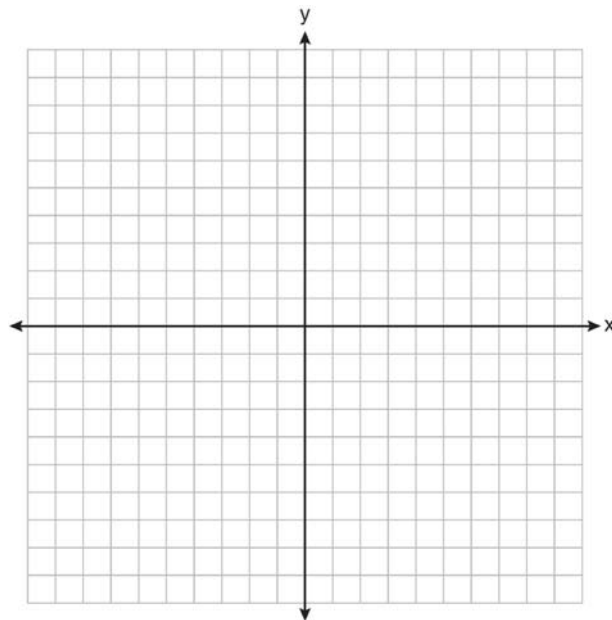

- 537 In the diagram below of $\triangle ADE$, B is a point on \overline{AE} and C is a point on \overline{AD} such that $\overline{BC} \parallel \overline{ED}$, $AC = x - 3$, $BE = 20$, $AB = 16$, and $AD = 2x + 2$. Find the length of \overline{AC} .

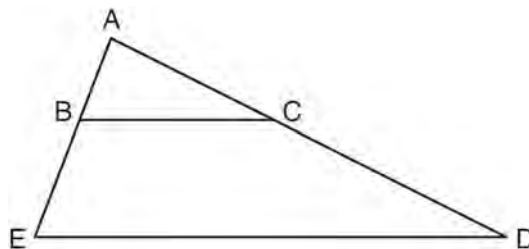

Geometry 4 Point Regents Exam Questions

www.jmap.org

- 538 Quadrilateral $MATH$ has coordinates $M(-6, -3)$, $A(-1, -3)$, $T(-2, -1)$, and $H(-4, -1)$. The image of quadrilateral $MATH$ after the composition $r_{x\text{-axis}} \circ T_{7,5}$ is quadrilateral $M''A''T''H''$. State and label the coordinates of $M''A''T''H''$. [The use of the set of axes below is optional.]

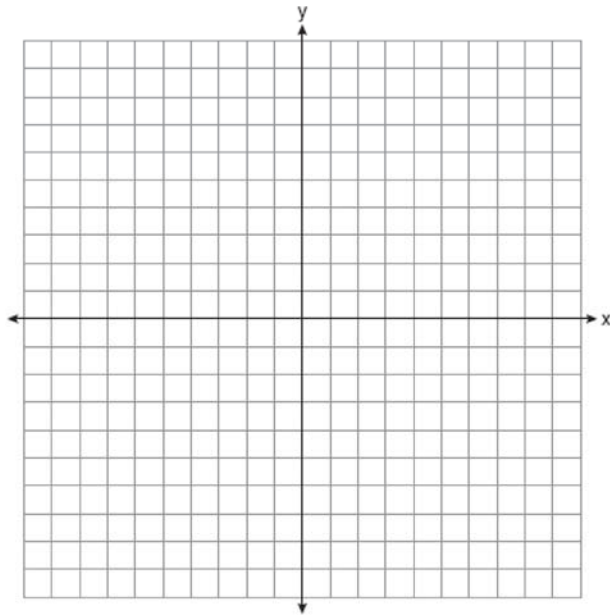

- 539 In the diagram below, \overline{BFCE} , $\overline{AB} \perp \overline{BE}$, $\overline{DE} \perp \overline{BE}$, and $\angle BFD \cong \angle ECA$. Prove that $\triangle ABC \sim \triangle DEF$.

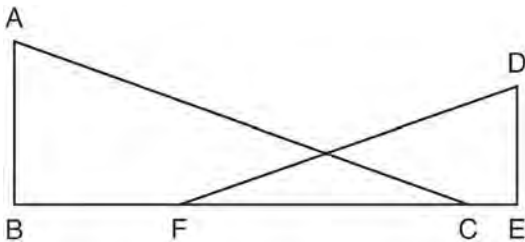

- 540 Given: \overline{AD} bisects \overline{BC} at E .
 $\overline{AB} \perp \overline{BC}$
 $\overline{DC} \perp \overline{BC}$
 Prove: $\overline{AB} \cong \overline{DC}$

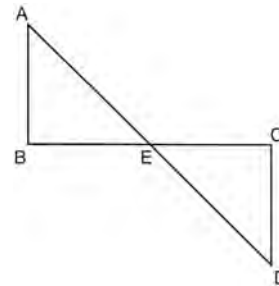

- 541 In $\triangle ABC$, $m\angle A = x^2 + 12$, $m\angle B = 11x + 5$, and $m\angle C = 13x - 17$. Determine the longest side of $\triangle ABC$.
- 542 Triangle HKL has vertices $H(-7, 2)$, $K(3, -4)$, and $L(5, 4)$. The midpoint of \overline{HL} is M and the midpoint of \overline{LK} is N . Determine and state the coordinates of points M and N . Justify the statement: \overline{MN} is parallel to \overline{HK} . [The use of the set of axes below is optional.]

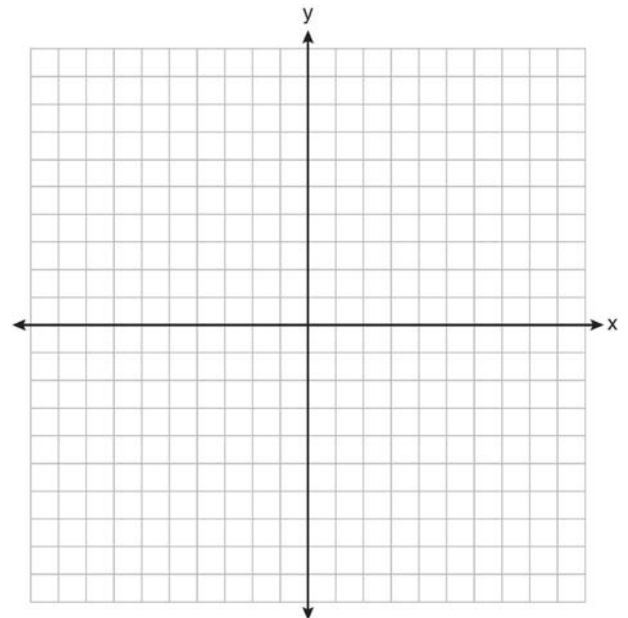

Geometry 4 Point Regents Exam Questions

www.jmap.org

- 543 The coordinates of the vertices of parallelogram $SWAN$ are $S(2, -2)$, $W(-2, -4)$, $A(-4, 6)$, and $N(0, 8)$. State and label the coordinates of parallelogram $S''W''A''N''$, the image of $SWAN$ after the transformation $T_{4, -2} \circ D_{\frac{1}{2}}$. [The use of the set of axes below is optional.]

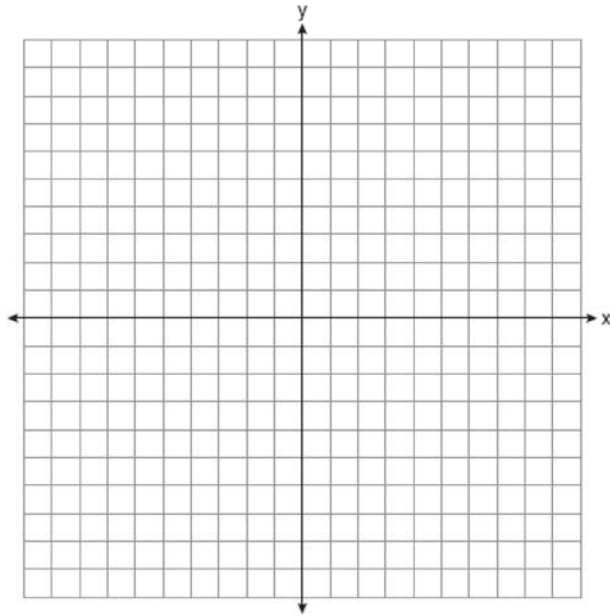

- 544 A right circular cylinder with a height of 5 cm has a base with a diameter of 6 cm. Find the lateral area of the cylinder to the nearest hundredth of a square centimeter. Find the volume of the cylinder to the nearest hundredth of a cubic centimeter.

- 545 Given: $\triangle ABC$, \overline{BD} bisects $\angle ABC$, $\overline{BD} \perp \overline{AC}$
 Prove: $\overline{AB} \cong \overline{CB}$

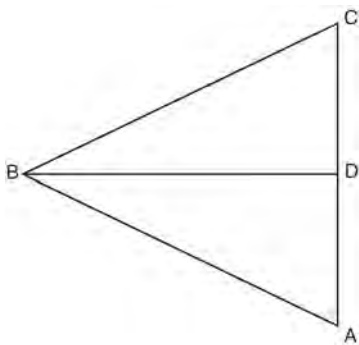

- 546 In $\triangle KLM$, $m\angle K = 36$ and $KM = 5$. The transformation D_2 is performed on $\triangle KLM$ to form $\triangle K'L'M'$. Find $m\angle K'$. Justify your answer. Find the length of $K'M'$. Justify your answer.
- 547 On the set of axes below, sketch the points that are 5 units from the origin and sketch the points that are 2 units from the line $y = 3$. Label with an **X** all points that satisfy both conditions.

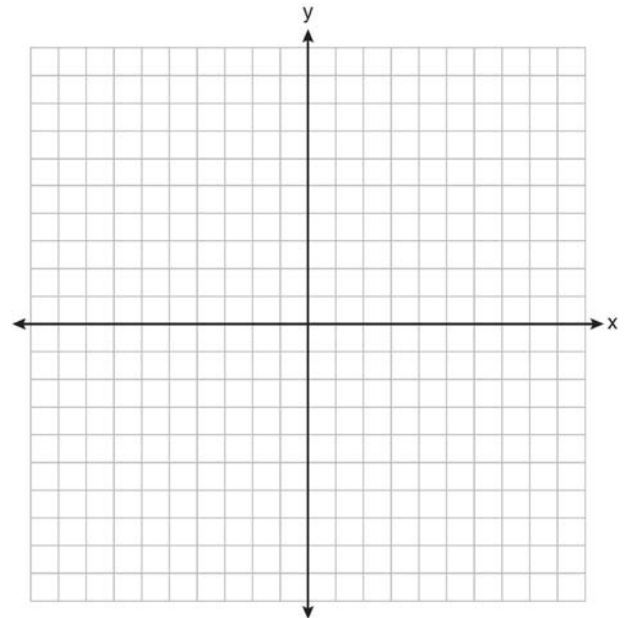

Geometry 4 Point Regents Exam Questions

www.jmap.org

- 548 In the diagram below of circle O , chords \overline{RT} and \overline{QS} intersect at M . Secant \overline{PTR} and tangent \overline{PS} are drawn to circle O . The length of \overline{RM} is two more than the length of \overline{TM} , $QM = 2$, $SM = 12$, and $PT = 8$.

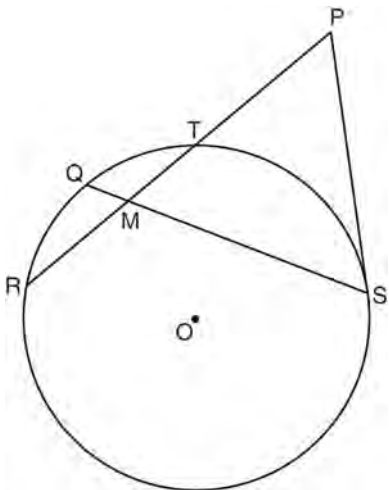

Find the length of \overline{RT} . Find the length of \overline{PS} .

- 549 Write an equation of the perpendicular bisector of the line segment whose endpoints are $(-1, 1)$ and $(7, -5)$. [The use of the grid below is optional]

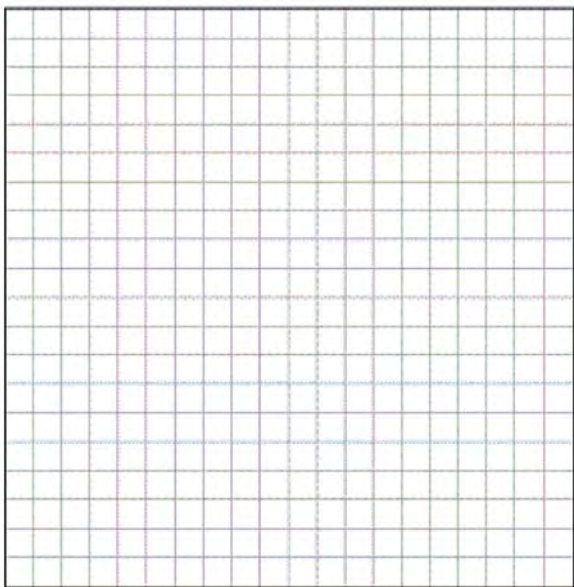

- 550 The coordinates of the vertices of $\triangle ABC$ are $A(1, 3)$, $B(-2, 2)$ and $C(0, -2)$. On the grid below, graph and label $\triangle A''B''C''$, the result of the composite transformation $D_2 \circ T_{3, -2}$. State the coordinates of A'' , B'' , and C'' .

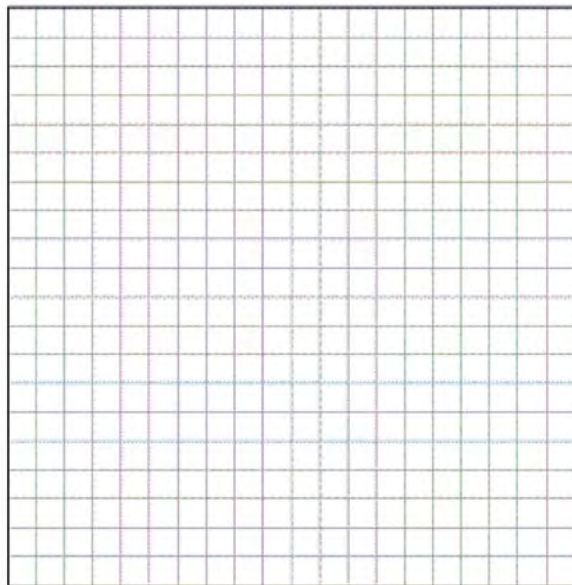

- 551 In the diagram below, tangent \overline{ML} and secant \overline{MNK} are drawn to circle O . The ratio $m\widehat{LN} : m\widehat{NK} : m\widehat{KL}$ is $3 : 4 : 5$. Find $m\angle LMK$.

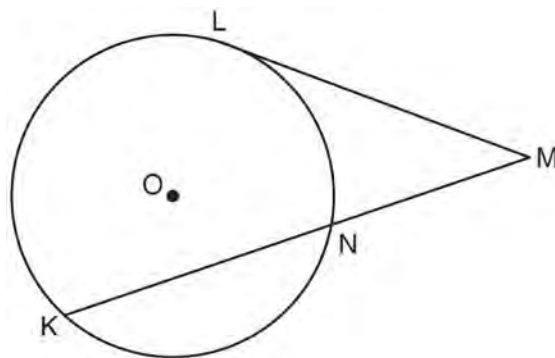

Geometry 4 Point Regents Exam Questions

www.jmap.org

- 552 The vertices of $\triangle RST$ are $R(-6, 5)$, $S(-7, -2)$, and $T(1, 4)$. The image of $\triangle RST$ after the composition $T_{-2, 3} \circ r_{y=x}$ is $\triangle R''S''T''$. State the coordinates of $\triangle R''S''T''$. [The use of the set of axes below is optional.]

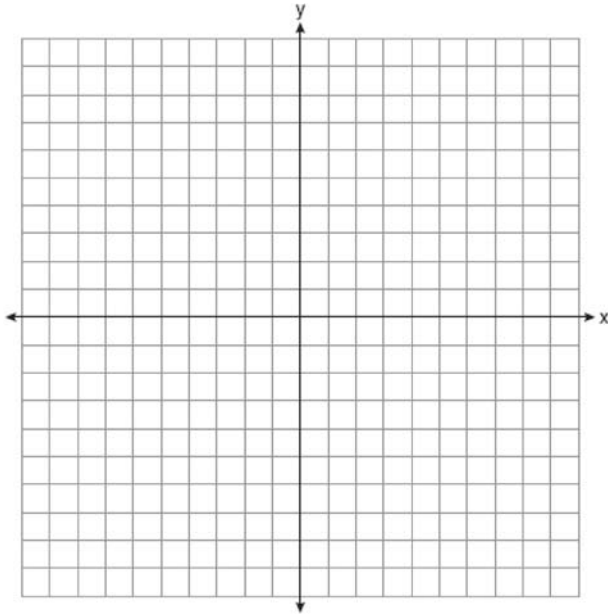

- 553 Triangle ABC has coordinates $A(2, -2)$, $B(2, 1)$, and $C(4, -2)$. Triangle $A'B'C'$ is the image of $\triangle ABC$ under $T_{5, -2}$. On the set of axes below, graph and label $\triangle ABC$ and its image, $\triangle A'B'C'$. Determine the relationship between the area of $\triangle ABC$ and the area of $\triangle A'B'C'$. Justify your response.

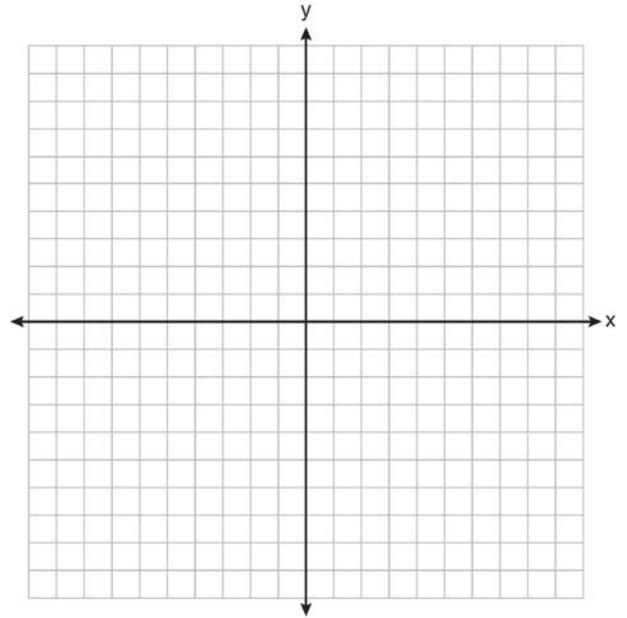

Geometry 4 Point Regents Exam Questions

www.jmap.org

- 554 On the set of coordinate axes below, graph the locus of points that are equidistant from the lines $y = 6$ and $y = 2$ and also graph the locus of points that are 3 units from the y -axis. State the coordinates of *all* points that satisfy *both* conditions.

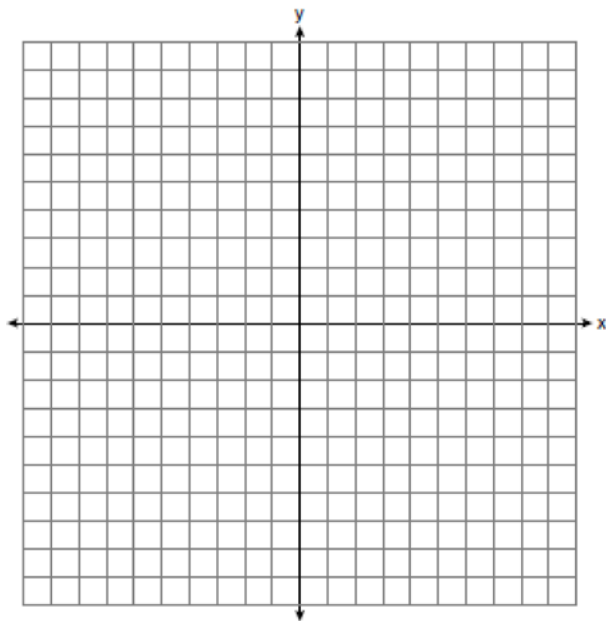

- 555 The coordinates of trapezoid $ABCD$ are $A(-4, 5)$, $B(1, 5)$, $C(1, 2)$, and $D(-6, 2)$. Trapezoid $A''B''C''D''$ is the image after the composition $r_{x\text{-axis}} \circ r_{y=x}$ is performed on trapezoid $ABCD$. State the coordinates of trapezoid $A''B''C''D''$. [The use of the set of axes below is optional.]

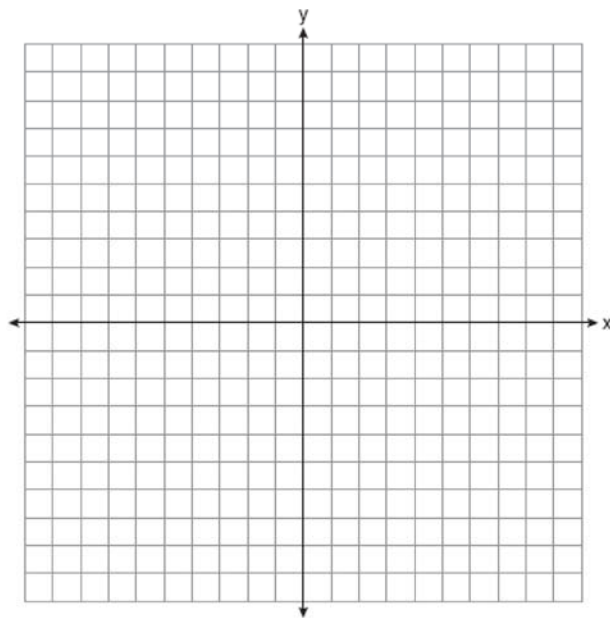

Geometry 6 Point Regents Exam Questions

- 556 On the set of axes below, solve the following system of equations graphically for all values of x and y .

$$y = (x - 2)^2 + 4$$

$$4x + 2y = 14$$

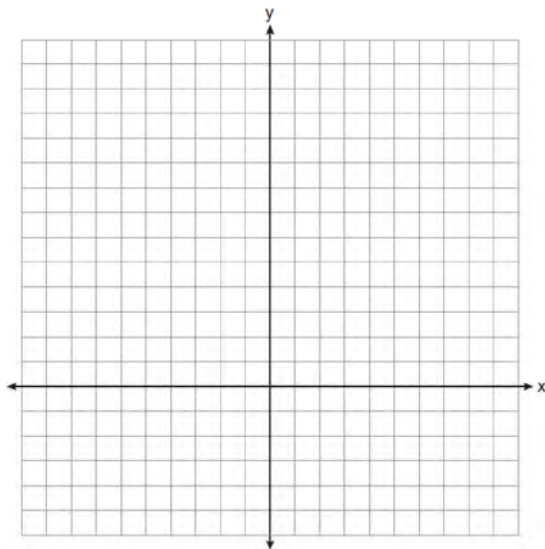

- 557 Given: Quadrilateral $ABCD$, diagonal AC , $AE \cong FC$, $BF \perp AC$, $DE \perp AC$, $\angle 1 \cong \angle 2$
Prove: $ABCD$ is a parallelogram.

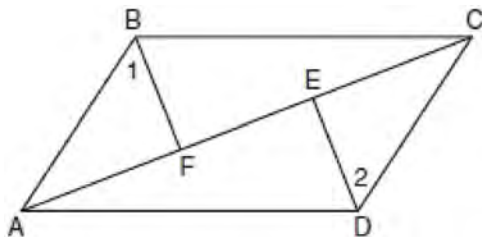

- 558 Given: $\triangle ABC$ and $\triangle EDC$, C is the midpoint of \overline{BD} and \overline{AE}
Prove: $\overline{AB} \parallel \overline{DE}$

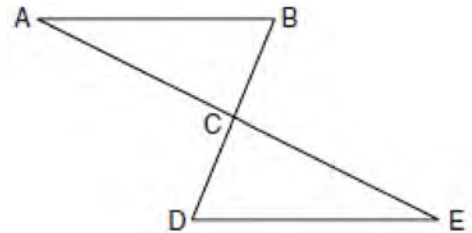

- 559 In the diagram below, quadrilateral $STAR$ is a rhombus with diagonals SA and TR intersecting at E . $ST = 3x + 30$, $SR = 8x - 5$, $SE = 3z$, $TE = 5z + 5$, $AE = 4z - 8$, $m\angle RTA = 5y - 2$, and $m\angle TAS = 9y + 8$. Find SR , RT , and $m\angle TAS$.

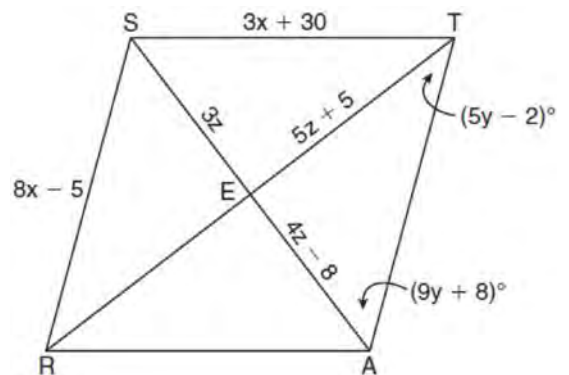

Geometry 6 Point Regents Exam Questions

www.jmap.org

- 560 Chords \overline{AB} and \overline{CD} intersect at E in circle O , as shown in the diagram below. Secant \overline{FDA} and tangent \overline{FB} are drawn to circle O from external point F and chord \overline{AC} is drawn. The $m\widehat{DA} = 56$, $m\widehat{DB} = 112$, and the ratio of $m\widehat{AC} : m\widehat{CB} = 3 : 1$.

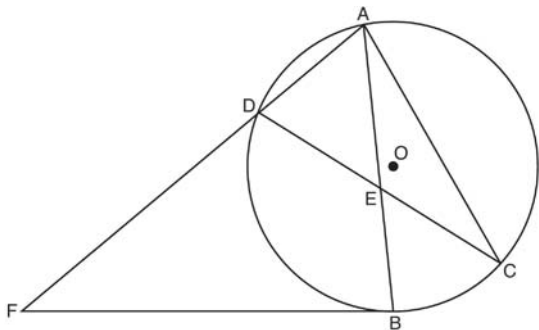

Determine $m\angle CEB$. Determine $m\angle F$. Determine $m\angle DAC$.

- 561 Quadrilateral $MATH$ has coordinates $M(1, 1)$, $A(-2, 5)$, $T(3, 5)$, and $H(6, 1)$. Prove that quadrilateral $MATH$ is a rhombus and prove that it is *not* a square. [The use of the grid is optional.]

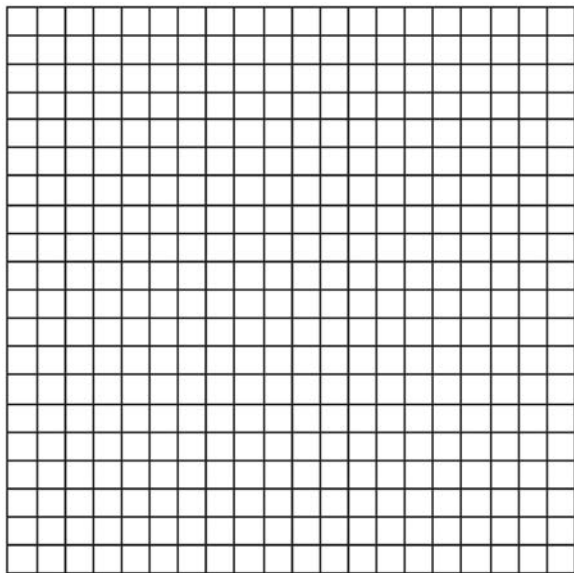

- 562 In the diagram below of quadrilateral $ABCD$, $AD \cong BC$ and $\angle DAE \cong \angle BCE$. Line segments AC , DB , and FG intersect at E .
Prove: $\triangle AEF \cong \triangle CEG$

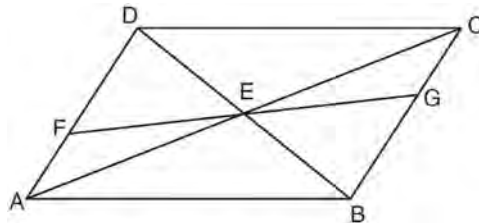

- 563 Quadrilateral $ABCD$ with vertices $A(-7, 4)$, $B(-3, 6)$, $C(3, 0)$, and $D(1, -8)$ is graphed on the set of axes below. Quadrilateral $MNPQ$ is formed by joining M , N , P , and Q , the midpoints of AB , BC , CD , and AD , respectively. Prove that quadrilateral $MNPQ$ is a parallelogram. Prove that quadrilateral $MNPQ$ is *not* a rhombus.

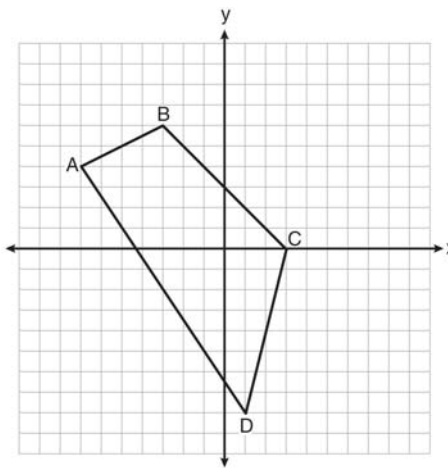

Geometry 6 Point Regents Exam Questions

www.jmap.org

- 564 Given: Quadrilateral $ABCD$ has vertices $A(-5, 6)$, $B(6, 6)$, $C(8, -3)$, and $D(-3, -3)$.
 Prove: Quadrilateral $ABCD$ is a parallelogram but is neither a rhombus nor a rectangle. [The use of the grid below is optional.]

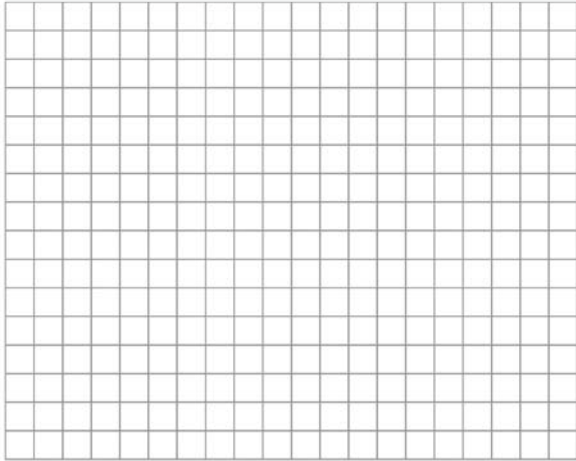

- 565 In the diagram below, \overline{PA} and \overline{PB} are tangent to circle O , \overline{OA} and \overline{OB} are radii, and \overline{OP} intersects the circle at C . Prove: $\angle AOP \cong \angle BOP$

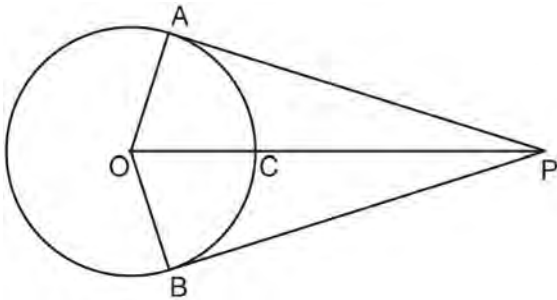

- 566 In the diagram below, quadrilateral $ABCD$ is inscribed in circle O , $\overline{AB} \parallel \overline{DC}$, and diagonals \overline{AC} and \overline{BD} are drawn. Prove that $\triangle ACD \cong \triangle BDC$.

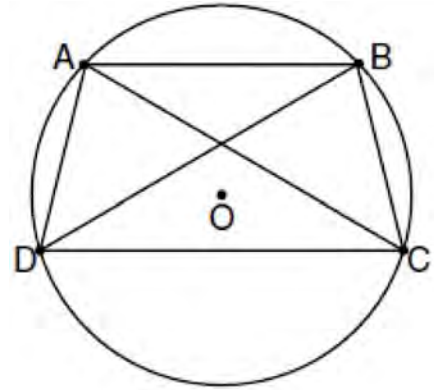

- 567 The diagram below shows rectangle $ABCD$ with points E and F on side \overline{AB} . Segments \overline{CE} and \overline{DF} intersect at G , and $\angle ADG \cong \angle BCG$. Prove: $\overline{AE} \cong \overline{BF}$

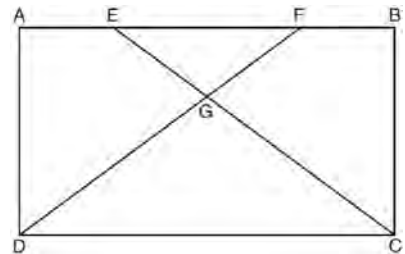

Geometry 6 Point Regents Exam Questions

www.jmap.org

- 568 On the set of axes below, solve the system of equations graphically and state the coordinates of all points in the solution.

$$y = (x - 2)^2 - 3$$

$$2y + 16 = 4x$$

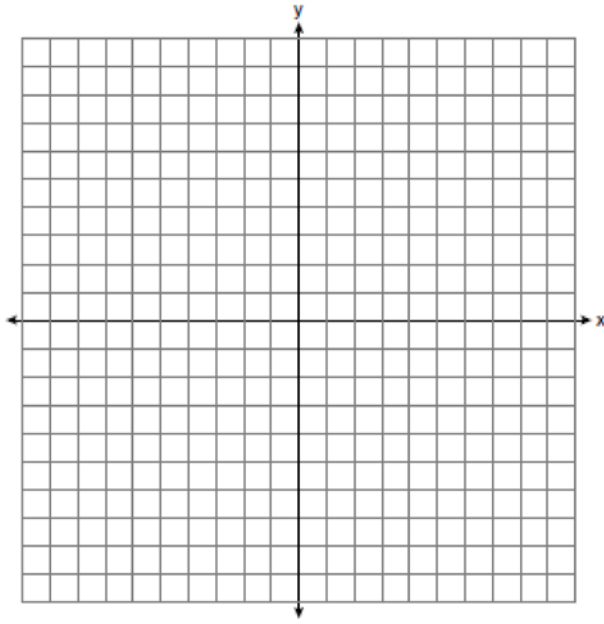

- 570 Given: $\triangle ABC$ with vertices $A(-6, -2)$, $B(2, 8)$, and $C(6, -2)$. \overline{AB} has midpoint D , \overline{BC} has midpoint E , and \overline{AC} has midpoint F .

Prove: $ADEF$ is a parallelogram

$ADEF$ is *not* a rhombus

[The use of the grid is optional.]

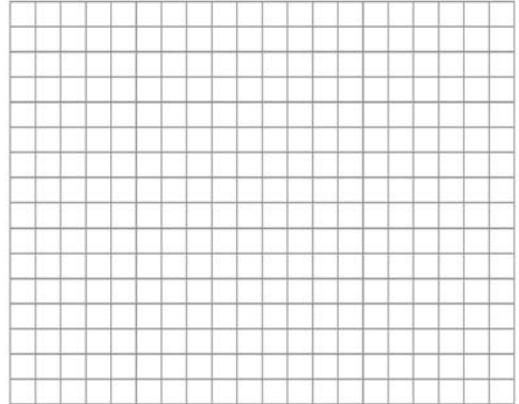

- 569 In the diagram of $\triangle MAH$ below, $\overline{MH} \cong \overline{AH}$ and medians \overline{AB} and \overline{MT} are drawn. Prove: $\angle MBA \cong \angle ATM$

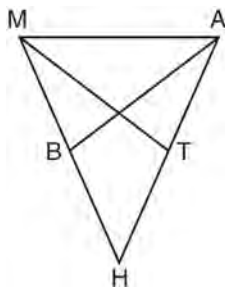

Geometry Multiple Choice Regents Exam Questions Answer Section

1 ANS: 3

$$3x - 15 = 2(6)$$

$$3x = 27$$

$$x = 9$$

PTS: 2

REF: 061311ge STA: G.G.42

TOP: Midsegments

2 ANS: 2

The slope of $2x + 4y = 12$ is $m = \frac{-A}{B} = \frac{-2}{4} = -\frac{1}{2}$. $m_{\perp} = 2$.

PTS: 2

REF: 011310ge STA: G.G.62

TOP: Parallel and Perpendicular Lines

3 ANS: 3

$$2y = 3x - 4 \quad 1 = \frac{3}{2}(6) + b$$

$$y = \frac{3}{2}x - 2 \quad 1 = 9 + b$$

$$-8 = b$$

PTS: 2

REF: 061316ge STA: G.G.65

TOP: Parallel and Perpendicular Lines

4 ANS: 3

$$2(4x + 20) + 2(3x - 15) = 360. \quad \angle D = 3(25) - 15 = 60$$

$$8x + 40 + 6x - 30 = 360$$

$$14x + 10 = 360$$

$$14x = 350$$

$$x = 25$$

PTS: 2

REF: 011321ge STA: G.G.40

TOP: Trapezoids

5 ANS: 4

$$m = \frac{2}{3} \quad 2 = -\frac{3}{2}(4) + b$$

$$m_{\perp} = -\frac{3}{2} \quad 2 = -6 + b$$

$$8 = b$$

PTS: 2

REF: 011319ge STA: G.G.64

TOP: Parallel and Perpendicular Lines

6 ANS: 1

$$8 \times 12 = 16x$$

$$6 = x$$

PTS: 2

REF: 081328ge STA: G.G.53

TOP: Segments Intercepted by Circle

KEY: two chords

- 7 ANS: 4 PTS: 2 REF: 011323ge STA: G.G.72
TOP: Equations of Circles
- 8 ANS: 4
 $2x - 8 = x + 2$. $AE = 10 + 2 = 12$. $AC = 2(AE) = 2(12) = 24$
 $x = 10$
- PTS: 2 REF: 011327ge STA: G.G.39 TOP: Special Parallelograms
- 9 ANS: 2 PTS: 2 REF: 061321ge STA: G.G.34
TOP: Angle Side Relationship
- 10 ANS: 1
 $V = \frac{4}{3} \pi r^3$
 $44.6022 = \frac{4}{3} \pi r^3$
 $10.648 \approx r^3$
 $2.2 \approx r$
- PTS: 2 REF: 061317ge STA: G.G.16 TOP: Volume and Surface Area
- 11 ANS: 2
 $\sqrt{8^2 + 15^2} = 17$
- PTS: 2 REF: 061326ge STA: G.G.39 TOP: Special Parallelograms
- 12 ANS: 3
 $\frac{15}{18} = \frac{5}{6}$
- PTS: 2 REF: 081317ge STA: G.G.45 TOP: Similarity
KEY: perimeter and area
- 13 ANS: 1 PTS: 2 REF: 011301ge STA: G.G.29
TOP: Triangle Congruency
- 14 ANS: 2 PTS: 2 REF: 061313ge STA: G.G.70
TOP: Quadratic-Linear Systems
- 15 ANS: 3
 $x^2 + 5^2 = 25$
 $x = 0$
- PTS: 2 REF: 011312ge STA: G.G.70 TOP: Quadratic-Linear Systems

16 ANS: 2

$$(x-4)^2 - 2 = -2x + 6. \quad y = -2(4) + 6 = -2$$

$$x^2 - 8x + 16 - 2 = -2x + 6 \quad y = -2(2) + 6 = 2$$

$$x^2 - 6x + 8 = 0$$

$$(x-4)(x-2) = 0$$

$$x = 4, 2$$

PTS: 2 REF: 081319ge STA: G.G.70 TOP: Quadratic-Linear Systems

17 ANS: 4

Distance is preserved after a rotation.

PTS: 2 REF: 081304ge STA: G.G.55 TOP: Properties of Transformations

18 ANS: 3

$$\text{midpoint: } \left(\frac{6+8}{2}, \frac{8+4}{2} \right) = (7, 6). \quad \text{slope: } \frac{8-4}{6-8} = \frac{4}{-2} = -2; \quad m_{\perp} = \frac{1}{2}. \quad 6 = \frac{1}{2}(7) + b$$

$$\frac{12}{2} = \frac{7}{2} + b$$

$$\frac{5}{12} = b$$

PTS: 2 REF: 081327ge STA: G.G.68 TOP: Perpendicular Bisector

19 ANS: 2

PTS: 2

REF: 081301ge

STA: G.G.24

TOP: Statements

20 ANS: 4

$$m_{\overleftrightarrow{AB}} = \frac{6-3}{7-5} = \frac{3}{2}. \quad m_{\overleftrightarrow{CD}} = \frac{4-0}{6-9} = \frac{4}{-3}$$

PTS: 2 REF: 061318ge STA: G.G.63 TOP: Parallel and Perpendicular Lines

21 ANS: 4

$$(n-2)180 - n \left(\frac{(n-2)180}{n} \right) = 180n - 360 - 180n + 180n - 360 = 180n - 720.$$

$$180(5) - 720 = 180$$

PTS: 2 REF: 081322ge STA: G.G.37 TOP: Interior and Exterior Angles of Polygons

22 ANS: 3

The centroid divides each median into segments whose lengths are in the ratio 2 : 1.

PTS: 2 REF: 081307ge STA: G.G.43 TOP: Centroid

23 ANS: 1

$$\frac{70-20}{2} = 25$$

PTS: 2 REF: 011325ge STA: G.G.51 TOP: Arcs Determined by Angles

KEY: outside circle

- 24 ANS: 2 PTS: 2 REF: 081306ge STA: G.G.34
TOP: Angle Side Relationship
- 25 ANS: 1
 $\frac{180 - 52}{2} = 64. \quad 180 - (90 + 64) = 26$
- PTS: 2 REF: 011314ge STA: G.G.30 TOP: Interior and Exterior Angles of Triangles
- 26 ANS: 3 PTS: 2 REF: 011311ge STA: G.G.42
TOP: Midsegments
- 27 ANS: 1 PTS: 2 REF: 061307ge STA: G.G.55
TOP: Properties of Transformations
- 28 ANS: 4 PTS: 2 REF: 011318ge STA: G.G.73
TOP: Equations of Circles
- 29 ANS: 2 PTS: 2 REF: 081316ge STA: G.G.23
TOP: Locus
- 30 ANS: 3 PTS: 2 REF: 081312ge STA: G.G.72
TOP: Equations of Circles
- 31 ANS: 4
 $(x,y) \rightarrow (-x,-y)$
- PTS: 2 REF: 061304ge STA: G.G.54 TOP: Rotations
- 32 ANS: 2
 $2^2 + 3^2 \neq 4^2$
- PTS: 2 REF: 011316ge STA: G.G.48 TOP: Pythagorean Theorem
- 33 ANS: 3 PTS: 2 REF: 061320ge STA: G.G.35
TOP: Parallel Lines and Transversals
- 34 ANS: 1 PTS: 2 REF: 061310ge STA: G.G.2
TOP: Planes
- 35 ANS: 1 PTS: 2 REF: 061325ge STA: G.G.74
TOP: Graphing Circles
- 36 ANS: 4 PTS: 2 REF: 081313ge STA: G.G.19
TOP: Constructions
- 37 ANS: 1 PTS: 2 REF: 011303ge STA: G.G.24
TOP: Statements
- 38 ANS: 3
 $AB = 8 - 4 = 4. \quad BC = \sqrt{(-2 - (-5))^2 + (8 - 6)^2} = \sqrt{13}. \quad AC = \sqrt{(-2 - (-5))^2 + (4 - 6)^2} = \sqrt{13}$
- PTS: 2 REF: 011328ge STA: G.G.69 TOP: Triangles in the Coordinate Plane

39 ANS: 3

$$x^2 = 2(2 + 10)$$

$$x^2 = 24$$

$$x = \sqrt{24} = \sqrt{4} \sqrt{6} = 2\sqrt{6}$$

PTS: 2 REF: 081326ge STA: G.G.47 TOP: Similarity

KEY: leg

40 ANS: 3

$$25 \times 9 \times 12 = 15^2 h$$

$$2700 = 15^2 h$$

$$12 = h$$

PTS: 2 REF: 061323ge STA: G.G.11 TOP: Volume

41 ANS: 3 PTS: 2 REF: 081320ge STA: G.G.42

TOP: Midsegments

42 ANS: 3 PTS: 2 REF: 011309ge STA: G.G.20

TOP: Constructions

43 ANS: 2

Perimeter of $\triangle DEF$ is $5 + 8 + 11 = 24$. $\frac{5}{24} = \frac{x}{60}$

$$24x = 300$$

$$x = 12.5$$

PTS: 2 REF: 011307ge STA: G.G.45 TOP: Similarity

KEY: perimeter and area

44 ANS: 1

Parallel chords intercept congruent arcs. $m\widehat{AC} = m\widehat{BD}$. $\frac{180 - 110}{2} = 35$.

PTS: 2 REF: 081302ge STA: G.G.52 TOP: Chords

45 ANS: 1

$$12(8) = x(6)$$

$$96 = 6x$$

$$16 = x$$

PTS: 2 REF: 061328ge STA: G.G.53 TOP: Segments Intercepted by Circle

KEY: two secants

46 ANS: 1 PTS: 2 REF: 081323ge STA: G.G.9

TOP: Planes

47 ANS: 4 PTS: 2 REF: 081318ge STA: G.G.26

TOP: Converse and Biconditional

48 ANS: 3

$$x^2 = 3 \times 12. \quad \sqrt{6^2 + 3^2} = \sqrt{45} = \sqrt{9} \sqrt{5} = 3\sqrt{5}$$

$$x = 6$$

PTS: 2 REF: 061327ge STA: G.G.47 TOP: Similarity
KEY: altitude

49 ANS: 4 PTS: 2 REF: 061319ge STA: G.G.73
TOP: Equations of Circles

50 ANS: 2 PTS: 2 REF: 011317ge STA: G.G.22
TOP: Locus

51 ANS: 3 PTS: 2 REF: 011322ge STA: G.G.49
TOP: Chords

52 ANS: 2

$$\frac{(n-2)180}{n} = 120$$

$$180n - 360 = 120n$$

$$60n = 360$$

$$n = 6$$

PTS: 2 REF: 011326ge STA: G.G.37 TOP: Interior and Exterior Angles of Polygons
53 ANS: 2 PTS: 2 REF: 081311ge STA: G.G.10
TOP: Solids

54 ANS: 3 PTS: 2 REF: 011304ge STA: G.G.56
TOP: Identifying Transformations

55 ANS: 4 PTS: 2 REF: 081308ge STA: G.G.49
TOP: Chords

56 ANS: 4
 $6x = x + 40 + 3x + 10. \quad m\angle CAB = 25 + 40 = 65$
 $6x = 4x + 50$
 $2x = 50$
 $x = 25$

PTS: 2 REF: 081310ge STA: G.G.32 TOP: Exterior Angle Theorem
57 ANS: 2

Isosceles or not, $\triangle RSV$ and $\triangle RST$ have a common base, and since \overline{RS} and \overline{VT} are bases, congruent altitudes.

PTS: 2 REF: 061301ge STA: G.G.40 TOP: Trapezoids
58 ANS: 2

$$\sqrt{15^2 - 12^2} = 9$$

PTS: 2 REF: 081325ge STA: G.G.50 TOP: Tangents
KEY: point of tangency
59 ANS: 3 PTS: 2 REF: 081309ge STA: G.G.29
TOP: Triangle Congruency

- 60 ANS: 1 PTS: 2 REF: 011320ge STA: G.G.26
TOP: Conditional Statements
- 61 ANS: 4
 $3y + 6 = 2x$ $2y - 3x = 6$
 $3y = 2x - 6$ $2y = 3x + 6$
 $y = \frac{2}{3}x - 2$ $y = \frac{3}{2}x + 3$
 $m = \frac{2}{3}$ $m = \frac{3}{2}$
- PTS: 2 REF: 081315ge STA: G.G.63 TOP: Parallel and Perpendicular Lines
- 62 ANS: 4 PTS: 2 REF: 061303ge STA: G.G.22
TOP: Locus
- 63 ANS: 2
 $\sqrt{(-2-4)^2 + (-3-(-1))^2} = \sqrt{40} = \sqrt{4} \sqrt{10} = 2\sqrt{10}$
- PTS: 2 REF: 011313ge STA: G.G.39 TOP: Special Parallelograms
- 64 ANS: 1 PTS: 2 REF: 061314ge STA: G.G.26
TOP: Converse and Biconditional
- 65 ANS: 1
If two prisms have equal heights and volume, the area of their bases is equal.
- PTS: 2 REF: 081321ge STA: G.G.11 TOP: Volume
- 66 ANS: 4 PTS: 2 REF: 081305ge STA: G.G.71
TOP: Equations of Circles
- 67 ANS: 2
 $M_x = \frac{8+(-3)}{2} = 2.5$. $M_y = \frac{-4+2}{2} = -1$.
- PTS: 2 REF: 061312ge STA: G.G.66 TOP: Midpoint
- 68 ANS: 3
 $120\pi = \pi(12)(l)$
 $10 = l$
- PTS: 2 REF: 081314ge STA: G.G.15 TOP: Volume and Lateral Area
- 69 ANS: 4 PTS: 2 REF: 011306ge STA: G.G.9
TOP: Planes
- 70 ANS: 2 PTS: 2 REF: 061322ge STA: G.G.51
TOP: Arcs Determined by Angles KEY: inscribed
- 71 ANS: 1 PTS: 2 REF: 081303ge STA: G.G.24
TOP: Negations
- 72 ANS: 1 PTS: 2 REF: 081324ge STA: G.G.74
TOP: Graphing Circles

73 ANS: 2

Parallel chords intercept congruent arcs. $\frac{360 - (104 + 168)}{2} = 44$

PTS: 2 REF: 011302ge STA: G.G.52 TOP: Chords

74 ANS: 2 PTS: 2 REF: 061305ge STA: G.G.18

TOP: Constructions

75 ANS: 2

(1) is true because of vertical angles. (3) and (4) are true because CPCTC.

PTS: 2 REF: 061302ge STA: G.G.29 TOP: Triangle Congruency

76 ANS: 3

$$m = \frac{-A}{B} = \frac{-3}{-2} = \frac{3}{2}$$

PTS: 2 REF: 011324ge STA: G.G.63 TOP: Parallel and Perpendicular Lines

77 ANS: 3

$$3x + 1 + 4x - 17 + 5x - 20 = 180. \quad 3(18) + 1 = 55$$

$$12x - 36 = 180 \quad 4(18) - 17 = 55$$

$$12x = 216 \quad 5(18) - 20 = 70$$

$$x = 18$$

PTS: 2 REF: 061308ge STA: G.G.30 TOP: Interior and Exterior Angles of Triangles

78 ANS: 3 PTS: 2 REF: 061309ge STA: G.G.72

TOP: Equations of Circles

79 ANS: 1

$$x^2 = 3 \times 12$$

$$x = 6$$

PTS: 2 REF: 011308ge STA: G.G.47 TOP: Similarity

KEY: altitude

80 ANS: 4 PTS: 2 REF: 011315ge STA: G.G.1

TOP: Planes

81 ANS: 2 PTS: 2 REF: 061315ge STA: G.G.13

TOP: Classifying Solids

Geometry Multiple Choice Regents Exam Questions

Answer Section

82 ANS: 1 PTS: 2 REF: 081116ge STA: G.G.7
TOP: Planes

83 ANS: 3 PTS: 2 REF: 061102ge STA: G.G.29
TOP: Triangle Congruency

84 ANS: 2
 $d = \sqrt{(-1 - 7)^2 + (9 - 4)^2} = \sqrt{64 + 25} = \sqrt{89}$

PTS: 2 REF: 061109ge STA: G.G.67 TOP: Distance
KEY: general

85 ANS: 2 PTS: 2 REF: 061208ge STA: G.G.19
TOP: Constructions

86 ANS: 2 PTS: 2 REF: 081226ge STA: G.G.69
TOP: Triangles in the Coordinate Plane

87 ANS: 4 PTS: 2 REF: 011222ge STA: G.G.34
TOP: Angle Side Relationship

88 ANS: 3 PTS: 2 REF: 011217ge STA: G.G.64
TOP: Parallel and Perpendicular Lines

89 ANS: 1

The diagonals of a parallelogram intersect at their midpoints. $M_{AC} \left(\frac{1+3}{2}, \frac{5+(-1)}{2} \right) = (2, 2)$

PTS: 2 REF: 061209ge STA: G.G.69 TOP: Quadrilaterals in the Coordinate Plane
90 ANS: 2 PTS: 2 REF: 011211ge STA: G.G.55
TOP: Properties of Transformations

91 ANS: 1 PTS: 2 REF: 061113ge STA: G.G.63
TOP: Parallel and Perpendicular Lines

92 ANS: 4

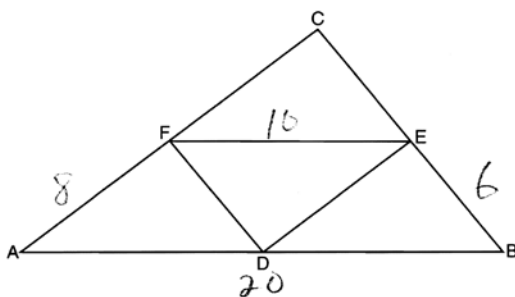

$$20 + 8 + 10 + 6 = 44.$$

PTS: 2 REF: 061211ge STA: G.G.42 TOP: Midsegments
93 ANS: 2 PTS: 2 REF: 011203ge STA: G.G.73
TOP: Equations of Circles

94 ANS: 4
 $\sqrt{25^2 - 7^2} = 24$

PTS: 2 REF: 081105ge STA: G.G.50 TOP: Tangents
 KEY: point of tangency

95 ANS: 4 PTS: 2 REF: 061203ge STA: G.G.9
 TOP: Planes

96 ANS: 2

The slope of a line in standard form is $-\frac{A}{B}$, so the slope of this line is $-\frac{4}{3}$. A parallel line would also have a slope of $-\frac{4}{3}$. Since the answers are in standard form, use the point-slope formula. $y - 2 = -\frac{4}{3}(x + 5)$

$$3y - 6 = -4x - 20$$

$$4x + 3y = -14$$

PTS: 2 REF: 061123ge STA: G.G.65 TOP: Parallel and Perpendicular Lines
 97 ANS: 3 PTS: 2 REF: 081104ge STA: G.G.55
 TOP: Properties of Transformations

98 ANS: 1

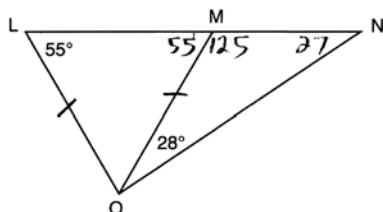

PTS: 2 REF: 061211ge STA: G.G.31 TOP: Isosceles Triangle Theorem
 99 ANS: 4 PTS: 2 REF: 081101ge STA: G.G.25
 TOP: Compound Statements KEY: conjunction
 100 ANS: 2

$$\frac{50+x}{2} = 34$$

$$50 + x = 68$$

$$x = 18$$

PTS: 2 REF: 011214ge STA: G.G.51 TOP: Arcs Determined by Angles
 KEY: inside circle

101 ANS: 2
 $V = \pi r^2 h = \pi \cdot 6^2 \cdot 15 = 540\pi$

PTS: 2 REF: 011117ge STA: G.G.14 TOP: Volume
 102 ANS: 2 PTS: 2 REF: 011215ge STA: G.G.12
 TOP: Volume

103 ANS: 4 PTS: 2 REF: 011108ge STA: G.G.27
 TOP: Angle Proofs

104 ANS: 1 PTS: 2 REF: 011213ge STA: G.G.24
TOP: Negations

105 ANS: 3

$$d = \sqrt{(1-9)^2 + (-4-2)^2} = \sqrt{64+36} = \sqrt{100} = 10$$

PTS: 2 REF: 081107ge STA: G.G.67 TOP: Distance
KEY: general

106 ANS: 4

$$\sqrt{25^2 - \left(\frac{26-12}{2}\right)^2} = 24$$

PTS: 2 REF: 011219ge STA: G.G.40 TOP: Trapezoids
107 ANS: 3 PTS: 2 REF: 081123ge STA: G.G.12
TOP: Volume

108 ANS: 1 PTS: 2 REF: 061125ge STA: G.G.39
TOP: Special Parallelograms

109 ANS: 3 PTS: 2 REF: 061306ge STA: G.G.71
TOP: Equations of Circles

110 ANS: 4 PTS: 2 REF: 011212ge STA: G.G.71
TOP: Equations of Circles

111 ANS: 2 PTS: 2 REF: 011109ge STA: G.G.9
TOP: Planes

112 ANS: 2 PTS: 2 REF: 061107ge STA: G.G.32
TOP: Exterior Angle Theorem

113 ANS: 3 PTS: 2 REF: 011105ge STA: G.G.10
TOP: Solids

114 ANS: 2 PTS: 2 REF: 081212ge STA: G.G.72
TOP: Equations of Circles

115 ANS: 4

\overline{AB} is a vertical line, so its perpendicular bisector is a horizontal line through the midpoint of \overline{AB} , which is (0, 3).

PTS: 2 REF: 011225ge STA: G.G.68 TOP: Perpendicular Bisector
116 ANS: 4 PTS: 2 REF: 061114ge STA: G.G.73
TOP: Equations of Circles

117 ANS: 2 PTS: 2 REF: 061201ge STA: G.G.59
TOP: Properties of Transformations

118 ANS: 4 PTS: 2 REF: 081110ge STA: G.G.71
TOP: Equations of Circles

119 ANS: 1 PTS: 2 REF: 061104ge STA: G.G.43
TOP: Centroid

120 ANS: 1

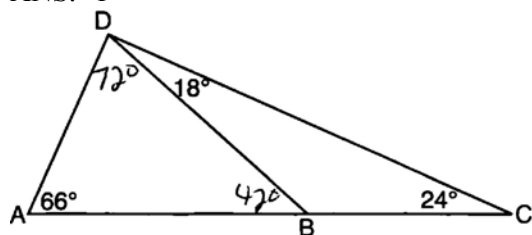

PTS: 2 REF: 081219ge STA: G.G.34 TOP: Angle Side Relationship

121 ANS: 3 PTS: 2 REF: 081111ge STA: G.G.32

TOP: Exterior Angle Theorem

122 ANS: 1

$$1 = \frac{-4+x}{2} \quad 5 = \frac{3+y}{2}$$

$$-4+x=2 \quad 3+y=10$$

$$x=6 \quad y=7$$

PTS: 2 REF: 081115ge STA: G.G.66 TOP: Midpoint

123 ANS: 4 PTS: 2 REF: 081216ge STA: G.G.45

TOP: Similarity KEY: basic

124 ANS: 3

$$\frac{3}{8+3+4} \times 180 = 36$$

PTS: 2 REF: 011210ge STA: G.G.30 TOP: Interior and Exterior Angles of Triangles

125 ANS: 4

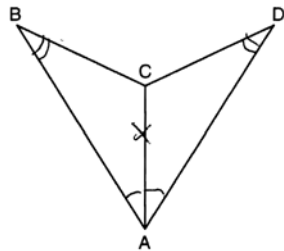

PTS: 2 REF: 081114ge STA: G.G.28 TOP: Triangle Congruency

126 ANS: 2 PTS: 2 REF: 081102ge STA: G.G.29

TOP: Triangle Congruency

127 ANS: 1 PTS: 2 REF: 061214ge STA: G.G.21

TOP: Centroid, Orthocenter, Incenter and Circumcenter

128 ANS: 3 PTS: 2 REF: 061228ge STA: G.G.39

TOP: Special Parallelograms

129 ANS: 4

$$m_{\perp} = -\frac{1}{3}. \quad y = mx + b$$

$$6 = -\frac{1}{3}(-9) + b$$

$$6 = 3 + b$$

$$3 = b$$

PTS: 2 REF: 061215ge STA: G.G.64 TOP: Parallel and Perpendicular Lines

130 ANS: 3

$$(3, -2) \rightarrow (2, 3) \rightarrow (8, 12)$$

PTS: 2 REF: 011126ge STA: G.G.54 TOP: Compositions of Transformations

KEY: basic

131 ANS: 1

PTS: 2

REF: 011220ge

STA: G.G.72

TOP: Equations of Circles

132 ANS: 3

PTS: 2

REF: 011116ge

STA: G.G.71

TOP: Equations of Circles

133 ANS: 3

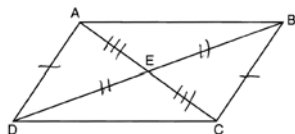

. Opposite sides of a parallelogram are congruent and the diagonals of a parallelogram bisect each other.

PTS: 2 REF: 061222ge STA: G.G.28 TOP: Triangle Congruency

134 ANS: 4

$$4(x + 4) = 8^2$$

$$4x + 16 = 64$$

$$4x = 48$$

$$x = 12$$

PTS: 2 REF: 061117ge STA: G.G.53 TOP: Segments Intercepted by Circle

KEY: tangent and secant

135 ANS: 4

PTS: 2

REF: 011208ge

STA: G.G.53

TOP: Segments Intercepted by Circle

KEY: two tangents

136 ANS: 3

$$\frac{7x}{4} = \frac{7}{x}. \quad 7(2) = 14$$

$$7x^2 = 28$$

$$x = 2$$

PTS: 2 REF: 061120ge STA: G.G.45 TOP: Similarity

KEY: basic

- 137 ANS: 1 PTS: 2 REF: 011207ge STA: G.G.20
TOP: Constructions
- 138 ANS: 2 PTS: 2 REF: 081205ge STA: G.G.17
TOP: Constructions
- 139 ANS: 4 PTS: 2 REF: 061118ge STA: G.G.1
TOP: Planes
- 140 ANS: 2
The diagonals of a rhombus are perpendicular. $180 - (90 + 12) = 78$
- PTS: 2 REF: 011204ge STA: G.G.39 TOP: Special Parallelograms
- 141 ANS: 1 PTS: 2 REF: 011128ge STA: G.G.2
TOP: Planes
- 142 ANS: 4 PTS: 2 REF: 011118ge STA: G.G.25
TOP: Compound Statements KEY: general
- 143 ANS: 3 PTS: 2 REF: 081208ge STA: G.G.27
TOP: Quadrilateral Proofs
- 144 ANS: 4
 $m = \frac{-A}{B} = \frac{-3}{2}$. $y = mx + b$
 $-1 = \left(\frac{-3}{2}\right)(2) + b$
 $-1 = -3 + b$
 $2 = b$
- PTS: 2 REF: 061226ge STA: G.G.65 TOP: Parallel and Perpendicular Lines
- 145 ANS: 1 PTS: 2 REF: 011112ge STA: G.G.39
TOP: Special Parallelograms
- 146 ANS: 3
 $4x + 14 + 8x + 10 = 180$
 $12x = 156$
 $x = 13$
- PTS: 2 REF: 081213ge STA: G.G.35 TOP: Parallel Lines and Transversals
- 147 ANS: 3 PTS: 2 REF: 081218ge STA: G.G.1
TOP: Planes
- 148 ANS: 3
 $x^2 + 7^2 = (x + 1)^2$ $x + 1 = 25$
 $x^2 + 49 = x^2 + 2x + 1$
 $48 = 2x$
 $24 = x$
- PTS: 2 REF: 081127ge STA: G.G.48 TOP: Pythagorean Theorem
- 149 ANS: 2 PTS: 2 REF: 011125ge STA: G.G.74
TOP: Graphing Circles

150 ANS: 3

$$(x - 2)180 = (5 - 2)180 = 540$$

PTS: 2

REF: 011223ge

STA: G.G.36

TOP: Interior and Exterior Angles of Polygons

151 ANS: 1

$$m = \left(\frac{8+0}{2}, \frac{2+6}{2} \right) = (4, 4) \quad m = \frac{6-2}{0-8} = \frac{4}{-8} = -\frac{1}{2} \quad m_{\perp} = 2 \quad y = mx + b$$

$$4 = 2(4) + b$$

$$-4 = b$$

PTS: 2

REF: 081126ge

STA: G.G.68

TOP: Perpendicular Bisector

152 ANS: 1

PTS: 2

REF: 061223ge

STA: G.G.73

TOP: Equations of Circles

153 ANS: 2

$$V = \frac{4}{3} \pi r^3 = \frac{4}{3} \pi \cdot 3^3 = 36\pi$$

PTS: 2

REF: 061112ge

STA: G.G.16

TOP: Volume and Surface Area

154 ANS: 3

PTS: 2

REF: 061122ge

STA: G.G.56

TOP: Identifying Transformations

155 ANS: 4

$$y = mx + b$$

$$3 = \frac{3}{2}(-2) + b$$

$$3 = -3 + b$$

$$6 = b$$

PTS: 2

REF: 011114ge

STA: G.G.65

TOP: Parallel and Perpendicular Lines

156 ANS: 3

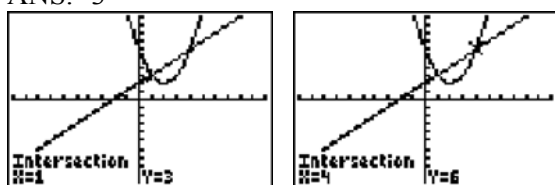

PTS: 2

REF: 081118ge

STA: G.G.70

TOP: Quadratic-Linear Systems

157 ANS: 2

PTS: 2

REF: 061101ge

STA: G.G.18

TOP: Constructions

158 ANS: 4

PTS: 2

REF: 061124ge

STA: G.G.31

TOP: Isosceles Triangle Theorem

159 ANS: 4

$$x \cdot 4x = 6^2. \quad PQ = 4x + x = 5x = 5(3) = 15$$

$$4x^2 = 36$$

$$x = 3$$

PTS: 2

REF: 011227ge

STA: G.G.47

TOP: Similarity

KEY: leg

160 ANS: 2

PTS: 2

REF: 061202ge

STA: G.G.24

TOP: Negations

161 ANS: 2

$$6x + 42 = 18x - 12$$

$$54 = 12x$$

$$x = \frac{54}{12} = 4.5$$

PTS: 2

REF: 011201ge

STA: G.G.35

TOP: Parallel Lines and Transversals

162 ANS: 3

$$7x = 5x + 30$$

$$2x = 30$$

$$x = 15$$

PTS: 2

REF: 081109ge

STA: G.G.35

TOP: Parallel Lines and Transversals

163 ANS: 3

PTS: 2

REF: 061111ge

STA: G.G.38

TOP: Parallelograms

164 ANS: 4

$$6^2 = x(x + 5)$$

$$36 = x^2 + 5x$$

$$0 = x^2 + 5x - 36$$

$$0 = (x + 9)(x - 4)$$

$$x = 4$$

PTS: 2

REF: 011123ge

STA: G.G.47

TOP: Similarity

KEY: leg

165 ANS: 1

PTS: 2

REF: 011218ge

STA: G.G.3

TOP: Planes

166 ANS: 1

PTS: 2

REF: 011102ge

STA: G.G.55

TOP: Properties of Transformations

167 ANS: 4

PTS: 2

REF: 081106ge

STA: G.G.17

TOP: Constructions

168 ANS: 3

PTS: 2

REF: 081227ge

STA: G.G.42

TOP: Midsegments

169 ANS: 3
 $\sqrt{5^2 + 12^2} = 13$

PTS: 2 REF: 061116ge STA: G.G.39 TOP: Special Parallelograms

170 ANS: 2
 $AC = BD$
 $AC - BC = BD - BC$
 $AB = CD$

PTS: 2 REF: 061206ge STA: G.G.27 TOP: Line Proofs

171 ANS: 4
 $\sqrt{6^2 - 2^2} = \sqrt{32} = \sqrt{16} \sqrt{2} = 4\sqrt{2}$

PTS: 2 REF: 081124ge STA: G.G.49 TOP: Chords

172 ANS: 4
 The slope of $3x + 5y = 4$ is $m = \frac{-A}{B} = \frac{-3}{5}$. $m_{\perp} = \frac{5}{3}$.

PTS: 2 REF: 061127ge STA: G.G.62 TOP: Parallel and Perpendicular Lines

173 ANS: 1 PTS: 2 REF: 061110ge STA: G.G.72
 TOP: Equations of Circles

174 ANS: 2 PTS: 2 REF: 081117ge STA: G.G.23
 TOP: Locus

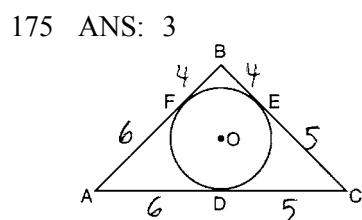

PTS: 2 REF: 011101ge STA: G.G.53 TOP: Segments Intercepted by Circle
 KEY: two tangents

176 ANS: 3
 $\frac{5}{7} = \frac{10}{x}$
 $5x = 70$
 $x = 14$

PTS: 2 REF: 081103ge STA: G.G.46 TOP: Side Splitter Theorem
 177 ANS: 4 PTS: 2 REF: 011216ge STA: G.G.29
 TOP: Triangle Congruency

178 ANS: 1

$$d = \sqrt{(4-1)^2 + (7-11)^2} = \sqrt{9+16} = \sqrt{25} = 5$$

PTS: 2 REF: 011205ge STA: G.G.67 TOP: Distance
KEY: general

179 ANS: 4

$$-5 = \frac{-3+x}{2}, \quad 2 = \frac{6+y}{2}$$

$$-10 = -3 + x \quad 4 = 6 + y$$

$$-7 = x \quad -2 = y$$

PTS: 2 REF: 081203ge STA: G.G.66 TOP: Midpoint
180 ANS: 3 PTS: 2 REF: 011209ge STA: G.G.44
TOP: Similarity Proofs

181 ANS: 4 PTS: 2 REF: 061213ge STA: G.G.5
TOP: Planes

182 ANS: 2

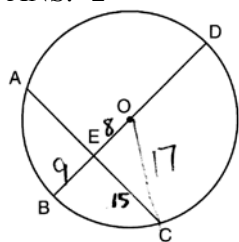

$$\sqrt{17^2 - 15^2} = 8, \quad 17 - 8 = 9$$

PTS: 2 REF: 061221ge STA: G.G.49 TOP: Chords
183 ANS: 2 PTS: 2 REF: 061121ge STA: G.G.22
TOP: Locus

184 ANS: 3

$$180(n-2) = n \left(180 - \frac{180(n-2)}{n} \right)$$

$$180n - 360 = 180n - 180n + 360$$

$$180n = 720$$

$$n = 4$$

PTS: 2 REF: 081223ge STA: G.G.36 TOP: Interior and Exterior Angles of Polygons
185 ANS: 2

$$V = \frac{4}{3} \pi r^3 = \frac{4}{3} \pi \cdot \left(\frac{15}{2} \right)^3 \approx 1767.1$$

PTS: 2 REF: 061207ge STA: G.G.16 TOP: Volume and Surface Area

186 ANS: 3

The slope of $2y = x + 2$ is $\frac{1}{2}$, which is the opposite reciprocal of -2 . $3 = -2(4) + b$
 $11 = b$

PTS: 2 REF: 081228ge STA: G.G.64 TOP: Parallel and Perpendicular Lines

187 ANS: 4 PTS: 2 REF: 081224ge STA: G.G.21

TOP: Centroid, Orthocenter, Incenter and Circumcenter

188 ANS: 2 PTS: 2 REF: 061324ge STA: G.G.44

TOP: Similarity Proofs

189 ANS: 3 PTS: 2 REF: 081209ge STA: G.G.71

TOP: Equations of Circles

190 ANS: 1 PTS: 2 REF: 061108ge STA: G.G.9

TOP: Planes

191 ANS: 2 PTS: 2 REF: 081202ge STA: G.G.55

TOP: Properties of Transformations

192 ANS: 2

$$3x + x + 20 + x + 20 = 180$$

$$5x = 40$$

$$x = 28$$

PTS: 2 REF: 081222ge STA: G.G.31 TOP: Isosceles Triangle Theorem

193 ANS: 2 PTS: 2 REF: 061227ge STA: G.G.56

TOP: Identifying Transformations

194 ANS: 1

$$m = \frac{3}{2} \quad y = mx + b$$

$$2 = \frac{3}{2}(1) + b$$

$$\frac{1}{2} = b$$

PTS: 2 REF: 081217ge STA: G.G.65 TOP: Parallel and Perpendicular Lines

195 ANS: 3 PTS: 2 REF: 081204ge STA: G.G.59

TOP: Properties of Transformations

196 ANS: 3 PTS: 2 REF: 061210ge STA: G.G.71

TOP: Equations of Circles

197 ANS: 1 PTS: 2 REF: 011221ge STA: G.G.10

TOP: Solids

198 ANS: 3 PTS: 2 REF: 061218ge STA: G.G.36

TOP: Interior and Exterior Angles of Polygons

199 ANS: 2 PTS: 2 REF: 081120ge STA: G.G.8

TOP: Planes

200 ANS: 1 PTS: 2 REF: 081113ge STA: G.G.54

TOP: Reflections KEY: basic

201 ANS: 3

The slope of $9x - 3y = 27$ is $m = \frac{-A}{B} = \frac{-9}{-3} = 3$, which is the opposite reciprocal of $-\frac{1}{3}$.

PTS: 2 REF: 081225ge STA: G.G.62 TOP: Parallel and Perpendicular Lines

202 ANS: 1

$$x^2 = 7(16 - 7)$$

$$x^2 = 63$$

$$x = \sqrt{9} \sqrt{7}$$

$$x = 3\sqrt{7}$$

PTS: 2 REF: 061128ge STA: G.G.47 TOP: Similarity

KEY: altitude

203 ANS: 2

$$7x = 5x + 30$$

$$2x = 30$$

$$x = 15$$

PTS: 2 REF: 061106ge STA: G.G.35 TOP: Parallel Lines and Transversals

204 ANS: 1

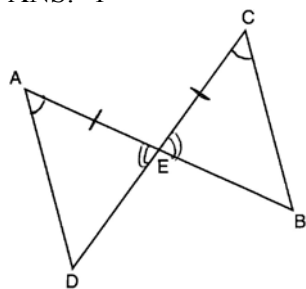

PTS: 2 REF: 081210ge STA: G.G.28 TOP: Triangle Congruency

205 ANS: 3 PTS: 2 REF: 081128ge STA: G.G.39

TOP: Special Parallelograms

206 ANS: 1 PTS: 2 REF: 081121ge STA: G.G.39

TOP: Special Parallelograms

207 ANS: 4

$$\frac{5}{2+3+5} \times 180 = 90$$

PTS: 2 REF: 081119ge STA: G.G.30 TOP: Interior and Exterior Angles of Triangles

208 ANS: 4

$$d = \sqrt{(-5-3)^2 + (4-(-6))^2} = \sqrt{64+100} = \sqrt{164} = \sqrt{4} \sqrt{41} = 2\sqrt{41}$$

PTS: 2 REF: 011121ge STA: G.G.67 TOP: Distance

KEY: general

209 ANS: 2

$$M_x = \frac{7+(-3)}{2} = 2. \quad M_y = \frac{-1+3}{2} = 1.$$

PTS: 2 REF: 011106ge STA: G.G.66 TOP: Midpoint

210 ANS: 2

$$m = \frac{-A}{B} = \frac{-20}{-2} = 10. \quad m_{\perp} = -\frac{1}{10}$$

PTS: 2 REF: 061219ge STA: G.G.62 TOP: Parallel and Perpendicular Lines

211 ANS: 2 PTS: 2 REF: 081108ge STA: G.G.54

TOP: Reflections KEY: basic

212 ANS: 4 PTS: 2 REF: 081211ge STA: G.G.5

TOP: Planes

213 ANS: 3

$$6 = \frac{4+x}{2}. \quad 8 = \frac{2+y}{2}.$$

$$4+x = 12 \quad 2+y = 16$$

$$x = 8 \quad y = 14$$

PTS: 2 REF: 011305ge STA: G.G.66 TOP: Midpoint

214 ANS: 4

The centroid divides each median into segments whose lengths are in the ratio 2 : 1.

PTS: 2 REF: 081220ge STA: G.G.43 TOP: Centroid

215 ANS: 3

$$\frac{180-70}{2} = 55$$

PTS: 2 REF: 061205ge STA: G.G.52 TOP: Chords

216 ANS: 3 PTS: 2 REF: 061220ge STA: G.G.74

TOP: Graphing Circles

217 ANS: 1

$$3x + 5 + 4x - 15 + 2x + 10 = 180. \quad m\angle D = 3(20) + 5 = 65. \quad m\angle E = 4(20) - 15 = 65.$$

$$9x = 180$$

$$x = 20$$

PTS: 2 REF: 061119ge STA: G.G.30 TOP: Interior and Exterior Angles of Triangles

218 ANS: 4
m∠A = 80

PTS: 2 REF: 011115ge STA: G.G.34 TOP: Angle Side Relationship

219 ANS: 1

$$7x + 4 = 2(2x + 5). \quad PM = 2(2) + 5 = 9$$

$$7x + 4 = 4x + 10$$

$$3x = 6$$

$$x = 2$$

PTS: 2 REF: 011226ge STA: G.G.43 TOP: Centroid

220 ANS: 2

$$m = \frac{-A}{B} = \frac{-4}{2} = -2 \quad y = mx + b$$

$$2 = -2(2) + b$$

$$6 = b$$

PTS: 2 REF: 081112ge STA: G.G.65 TOP: Parallel and Perpendicular Lines

221 ANS: 2 PTS: 2 REF: 061126ge STA: G.G.59

TOP: Properties of Transformations

222 ANS: 3 PTS: 2 REF: 011110ge STA: G.G.21

KEY: Centroid, Orthocenter, Incenter and Circumcenter

223 ANS: 3 PTS: 2 REF: 011202ge STA: G.G.21

TOP: Centroid, Orthocenter, Incenter and Circumcenter

224 ANS: 1

The length of the midsegment of a trapezoid is the average of the lengths of its bases. $\frac{x + 3 + 5x - 9}{2} = 2x + 2.$

$$6x - 6 = 4x + 4$$

$$2x = 10$$

$$x = 5$$

PTS: 2 REF: 081221ge STA: G.G.40 TOP: Trapezoids

225 ANS: 4

Parallel lines intercept congruent arcs.

PTS: 2 REF: 081201ge STA: G.G.52 TOP: Chords

226 ANS: 1

$$AB = CD$$

$$AB + BC = CD + BC$$

$$AC = BD$$

PTS: 2 REF: 081207ge STA: G.G.27 TOP: Triangle Proofs

227 ANS: 4

$$x^2 - 6x + 2x - 3 = 9x + 27$$

$$x^2 - 4x - 3 = 9x + 27$$

$$x^2 - 13x - 30 = 0$$

$$(x - 15)(x + 2) = 0$$

$$x = 15, -2$$

PTS: 2 REF: 061225ge STA: G.G.32 TOP: Exterior Angle Theorem

228 ANS: 2 PTS: 2 REF: 081214ge STA: G.G.50

TOP: Tangents KEY: point of tangency

229 ANS: 4 PTS: 2 REF: 061103ge STA: G.G.60

TOP: Identifying Transformations

230 ANS: 4

$$x + 6y = 12 \qquad 3(x - 2) = -y - 4$$

$$6y = -x + 12 \qquad -3(x - 2) = y + 4$$

$$y = -\frac{1}{6}x + 2 \qquad m = -3$$

$$m = -\frac{1}{6}$$

PTS: 2 REF: 011119ge STA: G.G.63 TOP: Parallel and Perpendicular Lines

231 ANS: 3

$$d = \sqrt{(-1 - 4)^2 + (0 - (-3))^2} = \sqrt{25 + 9} = \sqrt{34}$$

PTS: 2 REF: 061217ge STA: G.G.67 TOP: Distance

KEY: general

232 ANS: 3

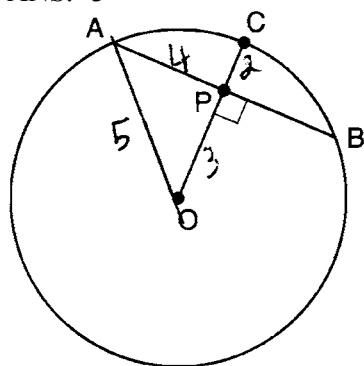

PTS: 2 REF: 011112ge STA: G.G.49 TOP: Chords

233 ANS: 3

$$-5 + 3 = -2 \qquad 2 + -4 = -2$$

PTS: 2 REF: 011107ge STA: G.G.54 TOP: Translations

234 ANS: 3

$$8^2 + 24^2 \neq 25^2$$

PTS: 2

REF: 011111ge

STA: G.G.48

TOP: Pythagorean Theorem

235 ANS: 3

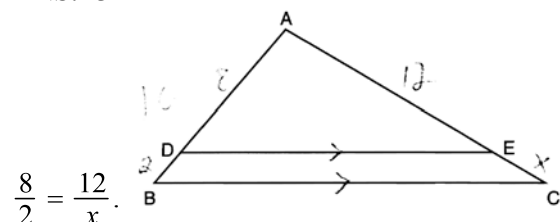

$$8x = 24$$

$$x = 3$$

PTS: 2

REF: 061216ge

STA: G.G.46

TOP: Side Splitter Theorem

236 ANS: 4

PTS: 2

REF: 011124ge

STA: G.G.51

TOP: Arcs Determined by Angles

KEY: inscribed

237 ANS: 2

The slope of $x + 2y = 3$ is $m = \frac{-A}{B} = \frac{-1}{2}$. $m_{\perp} = 2$.

PTS: 2

REF: 081122ge

STA: G.G.62

TOP: Parallel and Perpendicular Lines

238 ANS: 3

$$y = mx + b$$

$$-1 = 2(2) + b$$

$$-5 = b$$

PTS: 2

REF: 011224ge

STA: G.G.65

TOP: Parallel and Perpendicular Lines

239 ANS: 2

$$V = \frac{4}{3} \pi r^3 = \frac{4}{3} \pi \cdot \left(\frac{6}{2}\right)^3 \approx 36\pi$$

PTS: 2

REF: 081215ge

STA: G.G.16

TOP: Volume and Surface Area

240 ANS: 2

$$(n-2)180 = (6-2)180 = 720. \frac{720}{6} = 120.$$

PTS: 2

REF: 081125ge

STA: G.G.37

TOP: Interior and Exterior Angles of Polygons

241 ANS: 1

PTS: 2

REF: 011122ge

STA: G.G.28

TOP: Triangle Congruency

242 ANS: 1

PTS: 2

REF: 011120ge

STA: G.G.18

TOP: Constructions

243 ANS: 2

PTS: 2

REF: 061115ge

STA: G.G.69

TOP: Triangles in the Coordinate Plane

- 244 ANS: 2
 $5 - 3 = 2, 5 + 3 = 8$
- PTS: 2 REF: 011228ge STA: G.G.33 TOP: Triangle Inequality Theorem
- 245 ANS: 1
 Parallel lines intercept congruent arcs.
- PTS: 2 REF: 061105ge STA: G.G.52 TOP: Chords
- 246 ANS: 3 PTS: 2 REF: 061224ge STA: G.G.45
 TOP: Similarity KEY: basic
- 247 ANS: 2
 $\frac{4x + 10}{2} = 2x + 5$
- PTS: 2 REF: 011103ge STA: G.G.42 TOP: Midsegments
- 248 ANS: 2 PTS: 2 REF: 011206ge STA: G.G.32
 TOP: Exterior Angle Theorem
- 249 ANS: 3 PTS: 2 REF: 011104ge STA: G.G.38
 TOP: Parallelograms
- 250 ANS: 3
 $x + 2x + 15 = 5x + 15$ $2(5) + 15 = 25$
 $3x + 15 = 5x + 5$
 $10 = 2x$
 $5 = x$
- PTS: 2 REF: 011127ge STA: G.G.32 TOP: Exterior Angle Theorem

Geometry Multiple Choice Regents Exam Questions Answer Section

- 251 ANS: 2 PTS: 2 REF: 011006ge STA: G.G.56
TOP: Identifying Transformations
- 252 ANS: 3 PTS: 2 REF: 060925ge STA: G.G.17
TOP: Constructions
- 253 ANS: 3 PTS: 2 REF: 061017ge STA: G.G.1
TOP: Planes
- 254 ANS: 2
The centroid divides each median into segments whose lengths are in the ratio 2 : 1.

- PTS: 2 REF: 060914ge STA: G.G.43 TOP: Centroid
- 255 ANS: 1
 $3x^2 + 18x + 24$
 $3(x^2 + 6x + 8)$
 $3(x + 4)(x + 2)$

- PTS: 2 REF: fall0815ge STA: G.G.12 TOP: Volume
- 256 ANS: 2 PTS: 2 REF: 061007ge STA: G.G.35
TOP: Parallel Lines and Transversals
- 257 ANS: 3

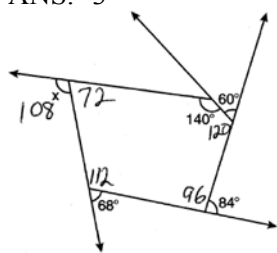

. The sum of the interior angles of a pentagon is $(5 - 2)180 = 540$.

- PTS: 2 REF: 011023ge STA: G.G.36 TOP: Interior and Exterior Angles of Polygons
- 258 ANS: 3 PTS: 2 REF: 080902ge STA: G.G.17
TOP: Constructions
- 259 ANS: 2 PTS: 2 REF: 061020ge STA: G.G.19
TOP: Constructions
- 260 ANS: 1 PTS: 2 REF: 011024ge STA: G.G.3
TOP: Planes
- 261 ANS: 3
 $\frac{36 + 20}{2} = 28$
- PTS: 2 REF: 061019ge STA: G.G.51 TOP: Arcs Determined by Angles
KEY: inside circle

262 ANS: 4

The slope of $y = -3x + 2$ is -3 . The perpendicular slope is $\frac{1}{3}$. $-1 = \frac{1}{3}(3) + b$

$$-1 = 1 + b$$

$$b = -2$$

PTS: 2 REF: 011018ge STA: G.G.64 TOP: Parallel and Perpendicular Lines

263 ANS: 1

$$V = \pi r^2 h$$

$$1000 = \pi r^2 \cdot 8$$

$$r^2 = \frac{1000}{8\pi}$$

$$r \approx 6.3$$

PTS: 2 REF: 080926ge STA: G.G.14 TOP: Volume

264 ANS: 1 PTS: 2 REF: 061012ge STA: G.G.20

TOP: Constructions

265 ANS: 3 PTS: 2 REF: 011010ge STA: G.G.71

TOP: Equations of Circles

266 ANS: 4

$$d = \sqrt{(146 - (-4))^2 + (52 - 2)^2} = \sqrt{25,000} \approx 158.1$$

PTS: 2 REF: 061021ge STA: G.G.67 TOP: Distance

KEY: general

267 ANS: 2 PTS: 2 REF: 011003ge STA: G.G.55

TOP: Properties of Transformations

268 ANS: 2 PTS: 2 REF: 061022ge STA: G.G.62

TOP: Parallel and Perpendicular Lines

269 ANS: 4

\overline{BG} is also an angle bisector since it intersects the concurrence of \overline{CD} and \overline{AE}

PTS: 2 REF: 061025ge STA: G.G.21

KEY: Centroid, Orthocenter, Incenter and Circumcenter

270 ANS: 2

Because the triangles are similar, $\frac{m\angle A}{m\angle D} = 1$

PTS: 2 REF: 011022ge STA: G.G.45 TOP: Similarity

KEY: perimeter and area

271 ANS: 3

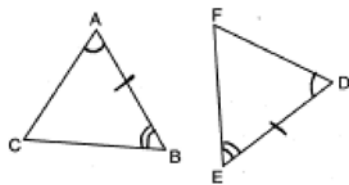

PTS: 2 REF: 060902ge STA: G.G.28 TOP: Triangle Congruency

272 ANS: 1

Parallel lines intercept congruent arcs.

PTS: 2 REF: 061001ge STA: G.G.52 TOP: Chords

273 ANS: 1

TOP: Constructions

PTS: 2 REF: fall0807ge STA: G.G.19

274 ANS: 4

TOP: Locus

PTS: 2 REF: 060912ge STA: G.G.23

275 ANS: 1

$A'(2, 4)$

PTS: 2 REF: 011023ge STA: G.G.54 TOP: Compositions of Transformations

KEY: basic

276 ANS: 3

TOP: Planes

PTS: 2 REF: fall0816ge STA: G.G.1

277 ANS: 1

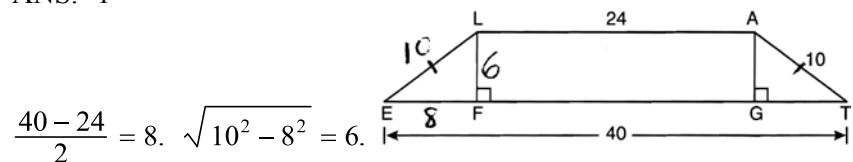

PTS: 2 REF: 061204ge STA: G.G.40 TOP: Trapezoids

278 ANS: 3

TOP: Constructions

PTS: 2 REF: fall0804ge STA: G.G.18

279 ANS: 1

TOP: Converse and Biconditional

PTS: 2 REF: 061009ge STA: G.G.26

280 ANS: 1

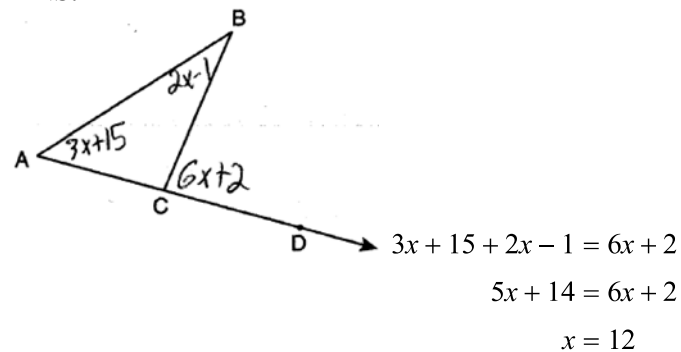

PTS: 2 REF: 011021ge STA: G.G.32 TOP: Exterior Angle Theorem

281 ANS: 4 PTS: 2 REF: 060913ge STA: G.G.26
TOP: Conditional Statements

282 ANS: 3

$$m = \frac{-A}{B} = -\frac{3}{4}$$

PTS: 2 REF: 011025ge STA: G.G.62 TOP: Parallel and Perpendicular Lines
283 ANS: 3 PTS: 2 REF: 080913ge STA: G.G.28
TOP: Triangle Congruency

284 ANS: 4 PTS: 2 REF: 080925ge STA: G.G.21
TOP: Centroid, Orthocenter, Incenter and Circumcenter

285 ANS: 1

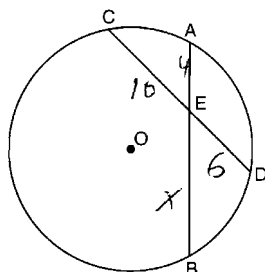

$$4x = 6 \cdot 10$$

$$x = 15$$

PTS: 2 REF: 081017ge STA: G.G.53 TOP: Segments Intercepted by Circle
KEY: two chords

286 ANS: 4 PTS: 2 REF: 061008ge STA: G.G.40
TOP: Trapezoids

287 ANS: 2 PTS: 2 REF: 060910ge STA: G.G.71
TOP: Equations of Circles

288 ANS: 1

$$\angle A = \frac{(n-2)180}{n} = \frac{(5-2)180}{5} = 108 \quad \angle AEB = \frac{180-108}{2} = 36$$

PTS: 2 REF: 081022ge STA: G.G.37 TOP: Interior and Exterior Angles of Polygons
289 ANS: 4 PTS: 2 REF: 011009ge STA: G.G.19
TOP: Constructions

290 ANS: 1

The closer a chord is to the center of a circle, the longer the chord.

PTS: 2 REF: 011005ge STA: G.G.49 TOP: Chords
291 ANS: 1

$$d = \sqrt{(-4-2)^2 + (5-(-5))^2} = \sqrt{36+100} = \sqrt{136} = \sqrt{4} \cdot \sqrt{34} = 2\sqrt{34}.$$

PTS: 2 REF: 080919ge STA: G.G.67 TOP: Distance
KEY: general
292 ANS: 2 PTS: 2 REF: 080927ge STA: G.G.4
TOP: Planes

293 ANS: 2

The slope of a line in standard form is $-\frac{A}{B}$, so the slope of this line is $\frac{-2}{-1} = 2$. A parallel line would also have a slope of 2. Since the answers are in slope intercept form, find the y-intercept:

$$y = mx + b$$

$$-11 = 2(-3) + b$$

$$-5 = b$$

PTS: 2 REF: fall0812ge STA: G.G.65 TOP: Parallel and Perpendicular Lines
 294 ANS: 1 PTS: 2 REF: 061005ge STA: G.G.55
 TOP: Properties of Transformations

295 ANS: 4 PTS: 2 REF: fall0824ge STA: G.G.50
 TOP: Tangents KEY: common tangency

296 ANS: 2

$$\frac{87 + 35}{2} = \frac{122}{2} = 61$$

PTS: 2 REF: 011015ge STA: G.G.51 TOP: Arcs Determined by Angles
 KEY: inside circle

297 ANS: 1 PTS: 2 REF: 060920ge STA: G.G.74
 TOP: Graphing Circles

298 ANS: 4

The radius is 4. $r^2 = 16$.

PTS: 2 REF: 061014ge STA: G.G.72 TOP: Equations of Circles
 299 ANS: 1

$$a^2 + (5\sqrt{2})^2 = (2\sqrt{15})^2$$

$$a^2 + (25 \times 2) = 4 \times 15$$

$$a^2 + 50 = 60$$

$$a^2 = 10$$

$$a = \sqrt{10}$$

PTS: 2 REF: 011016ge STA: G.G.48 TOP: Pythagorean Theorem
 300 ANS: 1

Translations and reflections do not affect distance.

PTS: 2 REF: 080908ge STA: G.G.61
 TOP: Analytical Representations of Transformations
 301 ANS: 3 PTS: 2 REF: fall0825ge STA: G.G.21
 TOP: Centroid, Orthocenter, Incenter and Circumcenter

302 ANS: 1 PTS: 2 REF: 060918ge STA: G.G.2
 TOP: Planes

303 ANS: 1

Opposite sides of a parallelogram are congruent. $4x - 3 = x + 3$. $SV = (2) + 3 = 5$.

$$3x = 6$$

$$x = 2$$

PTS: 2 REF: 011013ge STA: G.G.38 TOP: Parallelograms

304 ANS: 1

If $\angle A$ is at minimum (50°) and $\angle B$ is at minimum (90°), $\angle C$ is at maximum of 40° ($180^\circ - (50^\circ + 90^\circ)$). If $\angle A$ is at maximum (60°) and $\angle B$ is at maximum (100°), $\angle C$ is at minimum of 20° ($180^\circ - (60^\circ + 100^\circ)$).

PTS: 2 REF: 060901ge STA: G.G.30 TOP: Interior and Exterior Angles of Triangles

305 ANS: 4 PTS: 2 REF: fall0802ge STA: G.G.24

TOP: Negations

306 ANS: 1

$$V = \frac{1}{3} \pi r^2 h = \frac{1}{3} \pi \cdot 4^2 \cdot 12 \approx 201$$

PTS: 2 REF: 060921ge STA: G.G.15 TOP: Volume

307 ANS: 4

Longest side of a triangle is opposite the largest angle. Shortest side is opposite the smallest angle.

PTS: 2 REF: 081011ge STA: G.G.34 TOP: Angle Side Relationship

308 ANS: 4 PTS: 2 REF: 080905ge STA: G.G.29

TOP: Triangle Congruency

309 ANS: 3

The lateral edges of a prism are parallel.

PTS: 2 REF: fall0808ge STA: G.G.10 TOP: Solids

310 ANS: 1 PTS: 2 REF: 081012ge STA: G.G.50

TOP: Tangents KEY: two tangents

311 ANS: 4

sum of interior \angle s = sum of exterior \angle s

$$(n - 2)180 = n \left(180 - \frac{(n - 2)180}{n} \right)$$

$$180n - 360 = 180n - 180n + 360$$

$$180n = 720$$

$$n = 4$$

PTS: 2 REF: 081016ge STA: G.G.36 TOP: Interior and Exterior Angles of Polygons

312 ANS: 3

$2y = -6x + 8$ Perpendicular lines have slope the opposite and reciprocal of each other.

$$y = -3x + 4$$

$$m = -3$$

$$m_{\perp} = \frac{1}{3}$$

PTS: 2 REF: 081024ge STA: G.G.62 TOP: Parallel and Perpendicular Lines

313 ANS: 2

$$M_x = \frac{2 + (-4)}{2} = -1. \quad M_y = \frac{-3 + 6}{2} = \frac{3}{2}.$$

PTS: 2 REF: fall0813ge STA: G.G.66 TOP: Midpoint

KEY: general

314 ANS: 4

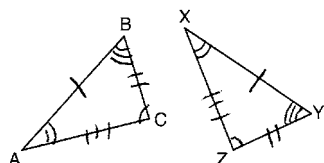

PTS: 2 REF: 081001ge STA: G.G.29 TOP: Triangle Congruency

315 ANS: 2

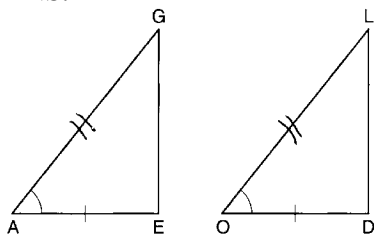

PTS: 2 REF: 081007ge STA: G.G.28 TOP: Triangle Congruency

316 ANS: 4 PTS: 2 REF: 060904ge STA: G.G.13

TOP: Solids

317 ANS: 1

The centroid divides each median into segments whose lengths are in the ratio 2 : 1.

$$\begin{aligned} \overline{GC} &= 2\overline{FG} \\ \overline{GC} + \overline{FG} &= 24 \\ 2\overline{FG} + \overline{FG} &= 24 \\ 3\overline{FG} &= 24 \\ \overline{FG} &= 8 \end{aligned}$$

PTS: 2 REF: 081018ge STA: G.G.43 TOP: Centroid

318 ANS: 3 PTS: 2 REF: 080928ge STA: G.G.50

TOP: Tangents KEY: common tangency

319 ANS: 4 PTS: 2 REF: 060922ge STA: G.G.73
TOP: Equations of Circles

320 ANS: 2
Adjacent sides of a rectangle are perpendicular and have opposite and reciprocal slopes.

PTS: 2 REF: 061028ge STA: G.G.69 TOP: Quadrilaterals in the Coordinate Plane
321 ANS: 1

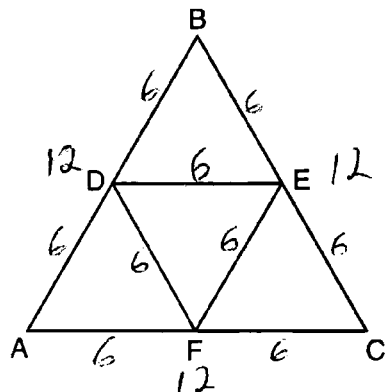

PTS: 2 REF: 081003ge STA: G.G.42 TOP: Midsegments
322 ANS: 4

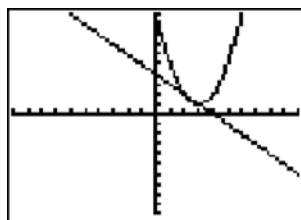

$$y + x = 4 \quad x^2 - 6x + 10 = -x + 4 \quad y + x = 4 \quad y + 2 = 4$$

$$y = -x + 4 \quad x^2 - 5x + 6 = 0 \quad y + 3 = 4 \quad y = 2$$

$$(x - 3)(x - 2) = 0 \quad y = 1$$

$$x = 3 \text{ or } 2$$

PTS: 2 REF: 080912ge STA: G.G.70 TOP: Quadratic-Linear Systems
323 ANS: 3

$$4(x + 4) = 8^2$$

$$4x + 16 = 64$$

$$x = 12$$

PTS: 2 REF: 060916ge STA: G.G.53 TOP: Segments Intercepted by Circle
KEY: tangent and secant
324 ANS: 3

$$V = \pi r^2 h = \pi \cdot 6^2 \cdot 27 = 972\pi$$

PTS: 2 REF: 011027ge STA: G.G.14 TOP: Volume

325 ANS: 4

$$\text{Let } \overline{AD} = x. \quad 36x = 12^2$$

$$x = 4$$

PTS: 2

REF: 080922ge

STA: G.G.47

TOP: Similarity

KEY: leg

326 ANS: 2

$$4(4x - 3) = 3(2x + 8)$$

$$16x - 12 = 6x + 24$$

$$10x = 36$$

$$x = 3.6$$

PTS: 2

REF: 080923ge

STA: G.G.53

TOP: Segments Intercepted by Circle

KEY: two chords

327 ANS: 3

PTS: 2

REF: 060908ge

STA: G.G.60

TOP: Identifying Transformations

328 ANS: 1

PTS: 2

REF: 081009ge

STA: G.G.73

TOP: Equations of Circles

329 ANS: 2

PTS: 2

REF: 080921ge

STA: G.G.72

TOP: Equations of Circles

330 ANS: 3

The slope of $y = x + 2$ is 1. The slope of $y - x = -1$ is $\frac{-A}{B} = \frac{-(-1)}{1} = 1$.

PTS: 2

REF: 080909ge

STA: G.G.63

TOP: Parallel and Perpendicular Lines

331 ANS: 3

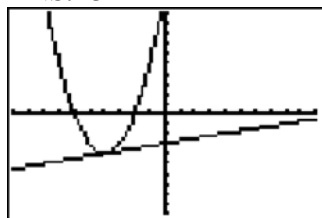

PTS: 2

REF: 061011ge

STA: G.G.70

TOP: Quadratic-Linear Systems

332 ANS: 1

$$x + 2x + 2 + 3x + 4 = 180$$

$$6x + 6 = 180$$

$$x = 29$$

PTS: 2

REF: 011002ge

STA: G.G.30

TOP: Interior and Exterior Angles of Triangles

333 ANS: 4

The marked 60° angle and the angle above it are on the same straight line and supplementary. This unmarked supplementary angle is 120° . Because the unmarked 120° angle and the marked 120° angle are alternate exterior angles and congruent, $d \parallel e$.

PTS: 2 REF: 080901ge STA: G.G.35 TOP: Parallel Lines and Transversals

334 ANS: 3 PTS: 2 REF: 060905ge STA: G.G.54

TOP: Reflections KEY: basic

335 ANS: 2

$$6 + 17 > 22$$

PTS: 2 REF: 080916ge STA: G.G.33 TOP: Triangle Inequality Theorem

336 ANS: 2 PTS: 2 REF: 081015ge STA: G.G.55

TOP: Properties of Transformations

337 ANS: 1

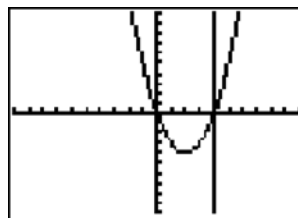

$$y = x^2 - 4x = (4)^2 - 4(4) = 0. \quad (4, 0) \text{ is the only intersection.}$$

PTS: 2 REF: 060923ge STA: G.G.70 TOP: Quadratic-Linear Systems

338 ANS: 2

$$y + \frac{1}{2}x = 4 \quad 3x + 6y = 12$$

$$y = -\frac{1}{2}x + 4 \quad 6y = -3x + 12$$

$$y = -\frac{3}{6}x + 2$$

$$m = -\frac{1}{2}$$

$$y = -\frac{1}{2}x + 2$$

PTS: 2 REF: 081014ge STA: G.G.63 TOP: Parallel and Perpendicular Lines

339 ANS: 4

$$180 - (40 + 40) = 100$$

PTS: 2 REF: 080903ge STA: G.G.31 TOP: Isosceles Triangle Theorem

340 ANS: 2

Parallel chords intercept congruent arcs. $\widehat{mAC} = \widehat{mBD} = 30$. $180 - 30 - 30 = 120$.

PTS: 2 REF: 080904ge STA: G.G.52 TOP: Chords

341 ANS: 2

$\angle ACB$ and $\angle ECD$ are congruent vertical angles and $\angle CAB \cong \angle CED$.

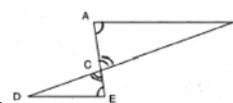

PTS: 2 REF: 060917ge STA: G.G.44 TOP: Similarity Proofs

342 ANS: 1

 $AB = 10$ since $\triangle ABC$ is a 6-8-10 triangle. $6^2 = 10x$

$$3.6 = x$$

PTS: 2

REF: 060915ge

STA: G.G.47

TOP: Similarity

KEY: leg

343 ANS: 4

The slope of $y = -\frac{2}{3}x - 5$ is $-\frac{2}{3}$. Perpendicular lines have slope that are opposite reciprocals.

PTS: 2

REF: 080917ge

STA: G.G.62

TOP: Parallel and Perpendicular Lines

344 ANS: 2

PTS: 2

REF: fall0806ge

STA: G.G.9

TOP: Planes

345 ANS: 3

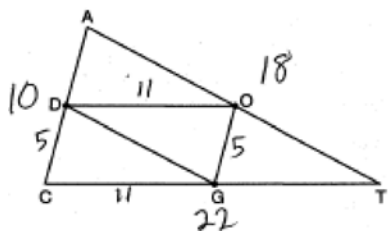

PTS: 2

REF: 080920ge

STA: G.G.42

TOP: Midsegments

346 ANS: 4

PTS: 2

REF: 061003ge

STA: G.G.10

TOP: Solids

347 ANS: 4

PTS: 2

REF: 061015ge

STA: G.G.56

TOP: Identifying Transformations

348 ANS: 4

$$d = \sqrt{(-3 - 1)^2 + (2 - 0)^2} = \sqrt{16 + 4} = \sqrt{20} = \sqrt{4} \cdot \sqrt{5} = 2\sqrt{5}$$

PTS: 2

REF: 011017ge

STA: G.G.67

TOP: Distance

KEY: general

349 ANS: 4

The slope of a line in standard form is $-\frac{A}{B}$, so the slope of this line is $-\frac{4}{2} = -2$. A parallel line would also have a slope of -2 . Since the answers are in slope intercept form, find the y -intercept: $y = mx + b$

$$3 = -2(7) + b$$

$$17 = b$$

PTS: 2

REF: 081010ge

STA: G.G.65

TOP: Parallel and Perpendicular Lines

350 ANS: 1

PTS: 2

REF: 061010ge

STA: G.G.34

TOP: Angle Side Relationship

351 ANS: 4

PTS: 2

REF: 081005ge

STA: G.G.18

TOP: Constructions

352 ANS: 3

PTS: 2

REF: 081026ge

STA: G.G.26

TOP: Contrapositive

353 ANS: 2
 $7 + 18 > 6 + 12$

PTS: 2 REF: fall0819ge STA: G.G.33 TOP: Triangle Inequality Theorem

354 ANS: 3

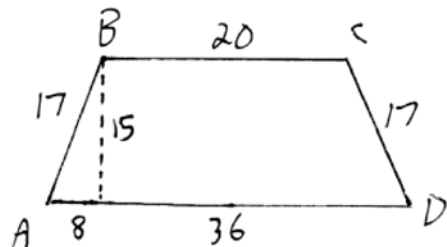

$$\frac{36-20}{2} = 8. \quad \sqrt{17^2 - 8^2} = 15$$

PTS: 2 REF: 061016ge STA: G.G.40 TOP: Trapezoids

355 ANS: 4 PTS: 2 REF: 081023ge STA: G.G.45
 TOP: Similarity KEY: perimeter and area

356 ANS: 1 PTS: 2 REF: 081028ge STA: G.G.21
 TOP: Centroid, Orthocenter, Incenter and Circumcenter

357 ANS: 2

$$\frac{3}{7} = \frac{6}{x}$$

$$3x = 42$$

$$x = 14$$

PTS: 2 REF: 081027ge STA: G.G.46 TOP: Side Splitter Theorem

358 ANS: 1

$\angle DCB$ and $\angle ADC$ are supplementary adjacent angles of a parallelogram. $180 - 120 = 60$. $\angle 2 = 60 - 45 = 15$.

PTS: 2 REF: 080907ge STA: G.G.38 TOP: Parallelograms

359 ANS: 2

A dilation affects distance, not angle measure.

PTS: 2 REF: 080906ge STA: G.G.60 TOP: Identifying Transformations

360 ANS: 1

$$(x, y) \rightarrow (x + 3, y + 1)$$

PTS: 2 REF: fall0803ge STA: G.G.54 TOP: Translations

361 ANS: 2 PTS: 2 REF: 011020ge STA: G.G.74
 TOP: Graphing Circles

362 ANS: 3 PTS: 2 REF: 061004ge STA: G.G.31
 TOP: Isosceles Triangle Theorem

363 ANS: 2

The slope of $2x + 3y = 12$ is $-\frac{A}{B} = -\frac{2}{3}$. The slope of a perpendicular line is $\frac{3}{2}$. Rewritten in slope intercept form, (2) becomes $y = \frac{3}{2}x + 3$.

PTS: 2 REF: 060926ge STA: G.G.63 TOP: Parallel and Perpendicular Lines

364 ANS: 3

The diagonals of an isosceles trapezoid are congruent. $5x + 3 = 11x - 5$.

$$6x = 18$$

$$x = 3$$

PTS: 2 REF: fall0801ge STA: G.G.40 TOP: Trapezoids

365 ANS: 3

$$(x + 3)^2 - 4 = 2x + 5$$

$$x^2 + 6x + 9 - 4 = 2x + 5$$

$$x^2 + 4x = 0$$

$$x(x + 4) = 0$$

$$x = 0, -4$$

PTS: 2 REF: 081004ge STA: G.G.70 TOP: Quadratic-Linear Systems

366 ANS: 4

PTS: 2
TOP: Identifying Transformations

REF: 061018ge

STA: G.G.56

367 ANS: 4

(4) is not true if $\angle PQR$ is obtuse.

PTS: 2 REF: 060924ge STA: G.G.32 TOP: Exterior Angle Theorem

368 ANS: 1

PTS: 2
TOP: Special Quadrilaterals

REF: 080918ge

STA: G.G.41

369 ANS: 4

PTS: 2
TOP: Identifying Transformations

REF: 080915ge

STA: G.G.56

370 ANS: 3

PTS: 2
TOP: Equations of Circles

REF: fall0814ge

STA: G.G.73

371 ANS: 2

PTS: 2
TOP: Constructions

REF: 011004ge

STA: G.G.17

372 ANS: 2

Longest side of a triangle is opposite the largest angle. Shortest side is opposite the smallest angle.

PTS: 2 REF: 060911ge STA: G.G.34 TOP: Angle Side Relationship

373 ANS: 3

$$m = \frac{-A}{B} = \frac{5}{2}. \quad m = \frac{-A}{B} = \frac{10}{4} = \frac{5}{2}$$

PTS: 2 REF: 011014ge STA: G.G.63 TOP: Parallel and Perpendicular Lines

- 374 ANS: 1 PTS: 2 REF: 060903ge STA: G.G.56
TOP: Identifying Transformations
- 375 ANS: 4 PTS: 2 REF: 011012ge STA: G.G.1
TOP: Planes
- 376 ANS: 4
 $L = 2\pi rh = 2\pi \cdot 5 \cdot 11 \approx 345.6$

PTS: 2 REF: 061006ge STA: G.G.14 TOP: Volume
- 377 ANS: 2
Parallel chords intercept congruent arcs. $m\widehat{AD} = m\widehat{BC} = 60$. $m\angle CDB = \frac{1}{2} m\widehat{BC} = 30$.

PTS: 2 REF: 060906ge STA: G.G.52 TOP: Chords
- 378 ANS: 2
 $M_x = \frac{-2+6}{2} = 2$. $M_y = \frac{-4+2}{2} = -1$

PTS: 2 REF: 080910ge STA: G.G.66 TOP: Midpoint
KEY: general
- 379 ANS: 1 PTS: 2 REF: 080911ge STA: G.G.73
TOP: Equations of Circles
- 380 ANS: 4
 $180 - (50 + 30) = 100$

PTS: 2 REF: 081006ge STA: G.G.45 TOP: Similarity
KEY: basic
- 381 ANS: 1
 $-2\left(-\frac{1}{2}y = 6x + 10\right)$
 $y = -12x - 20$

PTS: 2 REF: 061027ge STA: G.G.63 TOP: Parallel and Perpendicular Lines
- 382 ANS: 2
 $\frac{140 - \overline{RS}}{2} = 40$
 $140 - \overline{RS} = 80$
 $\overline{RS} = 60$

PTS: 2 REF: 081025ge STA: G.G.51 TOP: Arcs Determined by Angles
KEY: outside circle
- 383 ANS: 1
 $M_x = \frac{-2+6}{2} = 2$. $M_y = \frac{3+3}{2} = 3$. The center is (2, 3). $d = \sqrt{(-2-6)^2 + (3-3)^2} = \sqrt{64+0} = 8$. If the diameter is 8, the radius is 4 and $r^2 = 16$.

PTS: 2 REF: fall0820ge STA: G.G.71 TOP: Equations of Circles

384 ANS: 4

$$M_x = \frac{-6+1}{2} = -\frac{5}{2}. \quad M_y = \frac{1+8}{2} = \frac{9}{2}.$$

PTS: 2 REF: 060919ge STA: G.G.66 TOP: Midpoint

KEY: graph

385 ANS: 4 PTS: 2 REF: 081206ge STA: G.G.30

TOP: Interior and Exterior Angles of Triangles

386 ANS: 2

The slope of a line in standard form is $-\frac{A}{B}$ so the slope of this line is $-\frac{5}{3}$. Perpendicular lines have slope that are the opposite and reciprocal of each other.

PTS: 2 REF: fall0828ge STA: G.G.62 TOP: Parallel and Perpendicular Lines

387 ANS: 2

The slope of $y = \frac{1}{2}x + 5$ is $\frac{1}{2}$. The slope of a perpendicular line is -2 . $y = mx + b$
 $5 = (-2)(-2) + b$
 $b = 1$

PTS: 2 REF: 060907ge STA: G.G.64 TOP: Parallel and Perpendicular Lines

388 ANS: 2

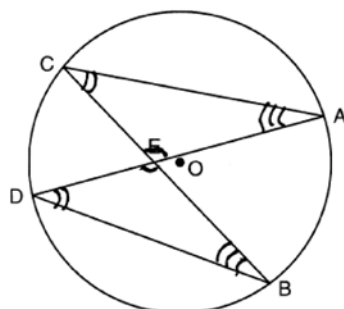

PTS: 2 REF: 061026GE STA: G.G.51 TOP: Arcs Determined by Angles

KEY: inscribed

389 ANS: 4 PTS: 2 REF: 080914ge STA: G.G.7

TOP: Planes

390 ANS: 3

Because \overline{OC} is a radius, its length is 5. Since $CE = 2$ $OE = 3$. $\triangle EDO$ is a 3-4-5 triangle. If $ED = 4$, $BD = 8$.

PTS: 2 REF: fall0811ge STA: G.G.49 TOP: Chords

391 ANS: 2 PTS: 2 REF: 011011ge STA: G.G.22

TOP: Locus

392 ANS: 4

$$3y + 1 = 6x + 4. \quad 2y + 1 = x - 9$$

$$3y = 6x + 3 \quad 2y = x - 10$$

$$y = 2x + 1 \quad y = \frac{1}{2}x - 5$$

PTS: 2 REF: fall0822ge STA: G.G.63 TOP: Parallel and Perpendicular Lines

393 ANS: 4

$$d = \sqrt{(-6 - 2)^2 + (4 - (-5))^2} = \sqrt{64 + 81} = \sqrt{145}$$

PTS: 2 REF: 081013ge STA: G.G.67 TOP: Distance

KEY: general

394 ANS: 1

After the translation, the coordinates are $A'(-1, 5)$ and $B'(3, 4)$. After the dilation, the coordinates are $A''(-2, 10)$ and $B''(6, 8)$.

PTS: 2 REF: fall0823ge STA: G.G.58 TOP: Compositions of Transformations

395 ANS: 1

$\triangle PRT$ and $\triangle SRQ$ share $\angle R$ and it is given that $\angle RPT \cong \angle RSQ$.

PTS: 2 REF: fall0821ge STA: G.G.44 TOP: Similarity Proofs

396 ANS: 4

TOP: Similarity Proofs

PTS: 2 REF: 011019ge STA: G.G.44

397 ANS: 2

$$M_x = \frac{3x + 5 + x - 1}{2} = \frac{4x + 4}{2} = 2x + 2. \quad M_y = \frac{3y + (-y)}{2} = \frac{2y}{2} = y.$$

PTS: 2 REF: 081019ge STA: G.G.66 TOP: Midpoint

KEY: general

398 ANS: 2

TOP: Negations

PTS: 2 REF: 061002ge STA: G.G.24

399 ANS: 4

$$\triangle ABC \sim \triangle DBE. \quad \frac{\overline{AB}}{\overline{DB}} = \frac{\overline{AC}}{\overline{DE}}$$

$$\frac{9}{2} = \frac{x}{3}$$

$$x = 13.5$$

PTS: 2 REF: 060927ge STA: G.G.46 TOP: Side Splitter Theorem

400 ANS: 1

Since $\overline{AC} \cong \overline{BC}$, $m\angle A = m\angle B$ under the Isosceles Triangle Theorem.

PTS: 2 REF: fall0809ge STA: G.G.69 TOP: Triangles in the Coordinate Plane

401 ANS: 3

TOP: Negations

PTS: 2 REF: 080924ge STA: G.G.24

402 ANS: 1 PTS: 2 REF: 061013ge STA: G.G.50
TOP: Tangents KEY: point of tangency

403 ANS: 4
 $x^2 = (4 + 5) \times 4$

$$x^2 = 36$$

$$x = 6$$

PTS: 2 REF: 011008ge STA: G.G.53 TOP: Segments Intercepted by Circle
KEY: tangent and secant

404 ANS: 4
Corresponding angles of similar triangles are congruent.

PTS: 2 REF: fall0826ge STA: G.G.45 TOP: Similarity
KEY: perimeter and area

405 ANS: 2
 $x^2 + (x + 7)^2 = 13^2$

$$x^2 + x^2 + 7x + 7x + 49 = 169$$

$$2x^2 + 14x - 120 = 0$$

$$x^2 + 7x - 60 = 0$$

$$(x + 12)(x - 5) = 0$$

$$x = 5$$

$$2x = 10$$

PTS: 2 REF: 061024ge STA: G.G.48 TOP: Pythagorean Theorem
406 ANS: 2

The length of the midsegment of a trapezoid is the average of the lengths of its bases. $\frac{x + 30}{2} = 44.$

$$x + 30 = 88$$

$$x = 58$$

PTS: 2 REF: 011001ge STA: G.G.40 TOP: Trapezoids
407 ANS: 3 PTS: 2 REF: 081002ge STA: G.G.9
TOP: Planes

408 ANS: 4
 $SA = 4\pi r^2 \quad V = \frac{4}{3}\pi r^3 = \frac{4}{3}\pi \cdot 6^3 = 288\pi$

$$144\pi = 4\pi r^2$$

$$36 = r^2$$

$$6 = r$$

PTS: 2 REF: 081020ge STA: G.G.16 TOP: Surface Area

409 ANS: 3 PTS: 2 REF: 011007ge STA: G.G.31
TOP: Isosceles Triangle Theorem

410 ANS: 1
In an equilateral triangle, each interior angle is 60° and each exterior angle is 120° ($180^\circ - 60^\circ$). The sum of the three interior angles is 180° and the sum of the three exterior angles is 360° .

PTS: 2 REF: 060909ge STA: G.G.30 TOP: Interior and Exterior Angles of Triangles
411 ANS: 4

$$(n-2)180 = (8-2)180 = 1080. \quad \frac{1080}{8} = 135.$$

PTS: 2 REF: fall0827ge STA: G.G.37 TOP: Interior and Exterior Angles of Polygons
412 ANS: 3 PTS: 2 REF: 011028ge STA: G.G.26
TOP: Conditional Statements

413 ANS: 2
 $(d+4)4 = 12(6)$
 $4d+16 = 72$
 $d = 14$
 $r = 7$

PTS: 2 REF: 061023ge STA: G.G.53 TOP: Segments Intercepted by Circle
KEY: two secants

414 ANS: 3

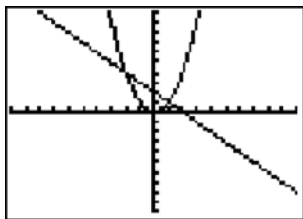

PTS: 2 REF: fall0805ge STA: G.G.70 TOP: Quadratic-Linear Systems
415 ANS: 1 PTS: 2 REF: 081008ge STA: G.G.3
TOP: Planes

416 ANS: 4 PTS: 2 REF: fall0818ge STA: G.G.61
TOP: Analytical Representations of Transformations

417 ANS: 2
 $x^2 = 3(x+18)$

$$x^2 - 3x - 54 = 0$$

$$(x-9)(x+6) = 0$$

$$x = 9$$

PTS: 2 REF: fall0817ge STA: G.G.53 TOP: Segments Intercepted by Circle
KEY: tangent and secant

- 418 ANS: 4
Median \overline{BF} bisects \overline{AC} so that $\overline{CF} \cong \overline{FA}$.
- PTS: 2 REF: fall0810ge STA: G.G.24 TOP: Statements
- 419 ANS: 3 PTS: 2 REF: 060928ge STA: G.G.8
TOP: Planes
- 420 ANS: 3 PTS: 2 REF: 081021ge STA: G.G.57
TOP: Properties of Transformations

Geometry 2 Point Regents Exam Questions

Answer Section

421 ANS: _____
 37. Since \overline{DE} is a midsegment, $AC = 14$. $10 + 13 + 14 = 37$

PTS: 2 REF: 061030ge STA: G.G.42 TOP: Midsegments

422 ANS:

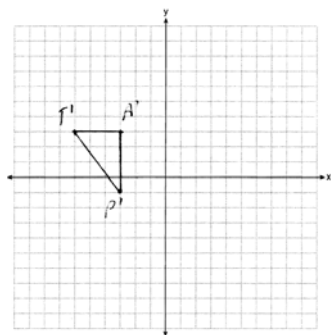

$T'(-6, 3), A'(-3, 3), P'(-3, -1)$

PTS: 2 REF: 061229ge STA: G.G.54 TOP: Translations

423 ANS:
 375π $L = \pi r l = \pi(15)(25) = 375\pi$

PTS: 2 REF: 081030ge STA: G.G.15 TOP: Lateral Area

424 ANS:

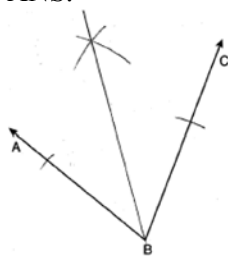

PTS: 2

REF: 080932ge

STA: G.G.17

TOP: Constructions

425 ANS:

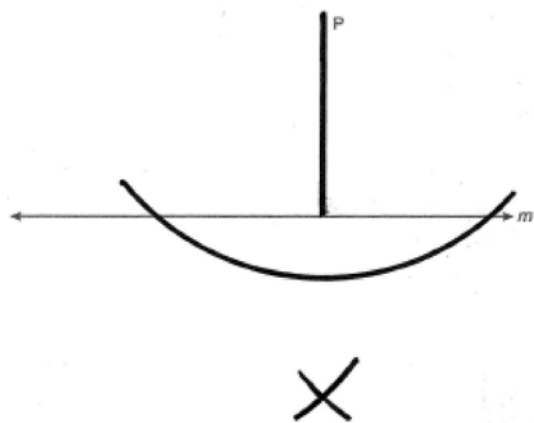

PTS: 2

REF: 060930ge

STA: G.G.19

TOP: Constructions

426 ANS:

$$m = \frac{-A}{B} = \frac{6}{2} = 3. \quad m_{\perp} = -\frac{1}{3}.$$

PTS: 2

REF: 011134ge

STA: G.G.62

TOP: Parallel and Perpendicular Lines

427 ANS:

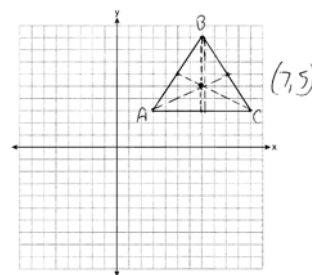

$$(7, 5) \quad m_{\overline{AB}} = \left(\frac{3+7}{2}, \frac{3+9}{2} \right) = (5, 6) \quad m_{\overline{BC}} = \left(\frac{7+11}{2}, \frac{9+3}{2} \right) = (9, 6)$$

PTS: 2

REF: 081134ge

STA: G.G.21

TOP: Centroid, Orthocenter, Incenter and Circumcenter

428 ANS:

$$x^2 = 9 \cdot 8$$

$$x = \sqrt{72}$$

$$x = \sqrt{36} \sqrt{2}$$

$$x = 6\sqrt{2}$$

PTS: 2

REF: 011132ge

STA: G.G.53

TOP: Segments Intercepted by Circle

KEY: two chords

429 ANS:

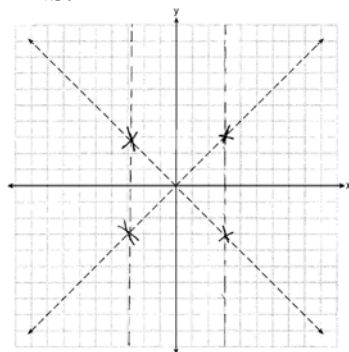

PTS: 2

REF: 081234ge

STA: G.G.23

TOP: Locus

430 ANS:

$$110. \quad 6x + 20 = x + 40 + 4x - 5$$

$$6x + 20 = 5x + 35$$

$$x = 15$$

$$6((15) + 20) = 110$$

PTS: 2

REF: 081031ge

STA: G.G.32

TOP: Exterior Angle Theorem

431 ANS:

$$\text{If } r = 5, \text{ then } r^2 = 25. \quad (x + 3)^2 + (y - 2)^2 = 25$$

PTS: 2

REF: 011332ge

STA: G.G.71

TOP: Equations of Circles

432 ANS:

$$V = \frac{4}{3} \pi \cdot 9^3 = 972\pi$$

PTS: 2

REF: 081131ge

STA: G.G.16

TOP: Surface Area

433 ANS:

$$452. \quad SA = 4\pi r^2 = 4\pi \cdot 6^2 = 144\pi \approx 452$$

PTS: 2

REF: 061029ge

STA: G.G.16

TOP: Surface Area

434 ANS:

$$18. \quad V = \frac{1}{3} Bh = \frac{1}{3} lwh$$

$$288 = \frac{1}{3} \cdot 8 \cdot 6 \cdot h$$

$$288 = 16h$$

$$18 = h$$

PTS: 2

REF: 061034ge

STA: G.G.13

TOP: Volume

435 ANS:

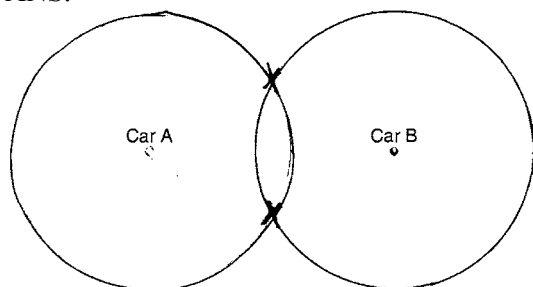

PTS: 2

REF: 081033ge

STA: G.G.22

TOP: Locus

436 ANS:

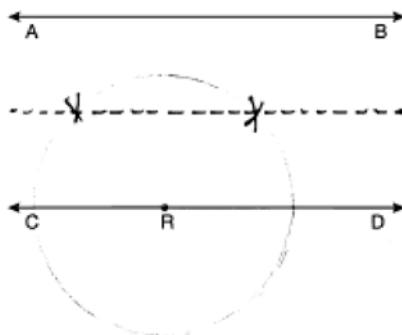

PTS: 2

REF: 061033ge

STA: G.G.22

TOP: Locus

437 ANS:

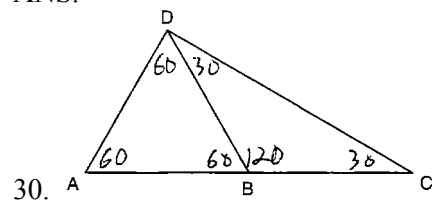

PTS: 2

REF: 011129ge

STA: G.G.31

TOP: Isosceles Triangle Theorem

438 ANS:

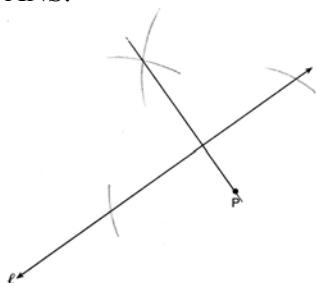

PTS: 2 REF: 011333ge STA: G.G.19 TOP: Constructions

439 ANS:

6. The centroid divides each median into segments whose lengths are in the ratio 2 : 1. $\overline{TD} = 6$ and $\overline{DB} = 3$

PTS: 2 REF: 011034ge STA: G.G.43 TOP: Centroid

440 ANS:

center: $(3, -4)$; radius: $\sqrt{10}$

PTS: 2 REF: 081333ge STA: G.G.73 TOP: Equations of Circles

441 ANS:

 $2x - 20 = x + 20$. $m\widehat{AB} = x + 20 = 40 + 20 = 60$

$$x = 40$$

PTS: 2 REF: 011229ge STA: G.G.52 TOP: Chords

442 ANS:

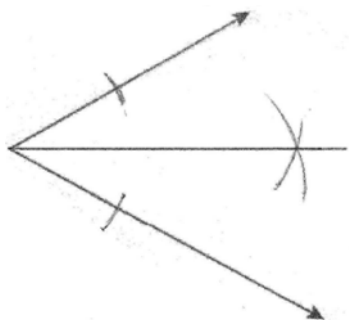

PTS: 2 REF: fall0832ge STA: G.G.17 TOP: Constructions

443 ANS:

2 is not a prime number, false.

PTS: 2 REF: 081229ge STA: G.G.24 TOP: Negations

444 ANS:

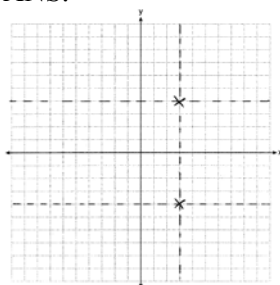

PTS: 2 REF: 061333ge STA: G.G.23 TOP: Locus

445 ANS:

The slope of $x + 2y = 4$ is $m = \frac{-A}{B} = \frac{-1}{2}$. The slope of $4y - 2x = 12$ is $\frac{-A}{B} = \frac{2}{4} = \frac{1}{2}$. Since the slopes are neither equal nor opposite reciprocals, the lines are neither parallel nor perpendicular.

PTS: 2 REF: 061231ge STA: G.G.63 TOP: Parallel and Perpendicular Lines

446 ANS:

9.1. $(11)(8)h = 800$

$$h \approx 9.1$$

PTS: 2 REF: 061131ge STA: G.G.12 TOP: Volume

447 ANS:

$$(x - 5)^2 + (y + 4)^2 = 36$$

PTS: 2 REF: 081132ge STA: G.G.72 TOP: Equations of Circles

448 ANS:

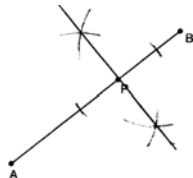

PTS: 2 REF: 081233ge STA: G.G.19 TOP: Constructions

449 ANS:

The slope of $y = 2x + 3$ is 2. The slope of $2y + x = 6$ is $\frac{-A}{B} = \frac{-1}{2}$. Since the slopes are opposite reciprocals, the lines are perpendicular.

PTS: 2 REF: 011231ge STA: G.G.63 TOP: Parallel and Perpendicular Lines

450 ANS:

5. $\frac{3}{x} = \frac{6+3}{15}$

$$9x = 45$$

$$x = 5$$

PTS: 2 REF: 011033ge STA: G.G.46 TOP: Side Splitter Theorem

451 ANS:

$$EO = 6. \quad CE = \sqrt{10^2 - 6^2} = 8$$

PTS: 2

REF: 011234ge

STA: G.G.49

TOP: Chords

452 ANS:

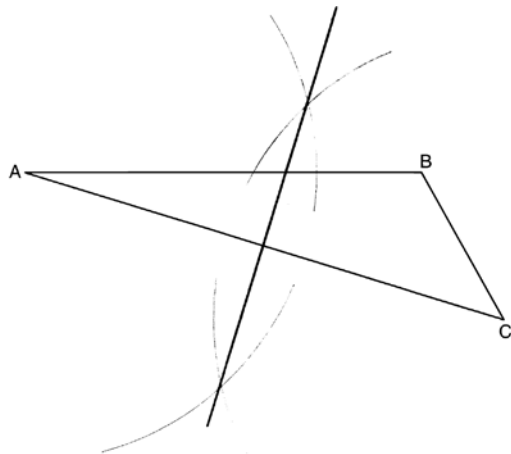

PTS: 2

REF: 081130ge

STA: G.G.18

TOP: Constructions

453 ANS:

$$(x + 1)^2 + (y - 2)^2 = 36$$

PTS: 2

REF: 081034ge

STA: G.G.72

TOP: Equations of Circles

454 ANS:

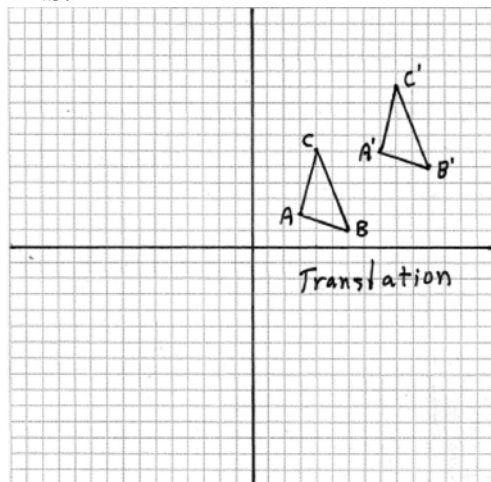

PTS: 2

REF: fall0830ge

STA: G.G.55

TOP: Properties of Transformations

455 ANS:

20. The sides of the triangle formed by connecting the midpoints are half the sides of the original triangle.

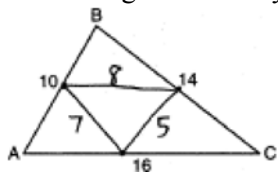

$$5 + 7 + 8 = 20.$$

PTS: 2 REF: 060929ge STA: G.G.42 TOP: Midsegments

456 ANS:

$$m_{\overline{AB}} = \frac{4-1}{4-2} = \frac{3}{2}, m_{\overline{BC}} = -\frac{2}{3}$$

PTS: 4 REF: 061334ge STA: G.G.69 TOP: Quadrilaterals in the Coordinate Plane

457 ANS:

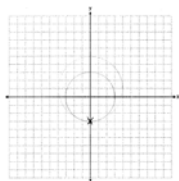

PTS: 2 REF: 011331ge STA: G.G.23 TOP: Locus

458 ANS:

$$16.7. \frac{x}{25} = \frac{12}{18}$$

$$18x = 300$$

$$x \approx 16.7$$

PTS: 2 REF: 061133ge STA: G.G.46 TOP: Side Splitter Theorem

459 ANS:

$$25. d = \sqrt{(-3-4)^2 + (1-25)^2} = \sqrt{49 + 576} = \sqrt{625} = 25.$$

PTS: 2 REF: fall0831ge STA: G.G.67 TOP: Distance

KEY: general

460 ANS:

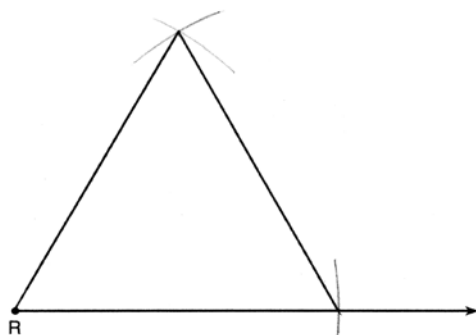

PTS: 2 REF: 061332ge STA: G.G.20 TOP: Constructions

461 ANS:
The medians of a triangle are not concurrent. False.

PTS: 2 REF: 061129ge STA: G.G.24 TOP: Negations

462 ANS:
67. $\frac{180 - 46}{2} = 67$

PTS: 2 REF: 011029ge STA: G.G.31 TOP: Isosceles Triangle Theorem

463 ANS:
 $180 - (90 + 63) = 27$

PTS: 2 REF: 061230ge STA: G.G.35 TOP: Parallel Lines and Transversals

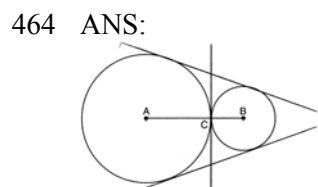

PTS: 2 REF: 011330ge STA: G.G.50 TOP: Tangents
KEY: common tangency

465 ANS:
 $L = 2\pi rh = 2\pi \cdot 3 \cdot 7 = 42\pi$

PTS: 2 REF: 061329ge STA: G.G.14 TOP: Volume

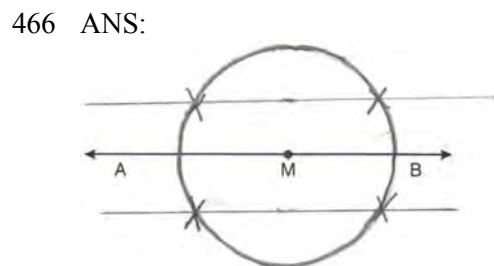

PTS: 2 REF: 011230ge STA: G.G.22 TOP: Locus

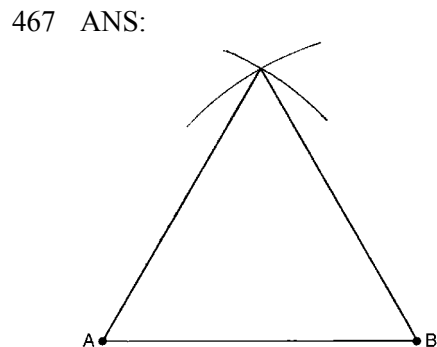

PTS: 2 REF: 081032ge STA: G.G.20 TOP: Constructions

468 ANS:

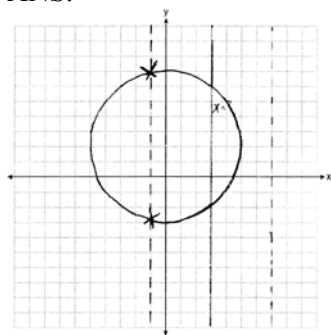

PTS: 2 REF: 061234ge STA: G.G.23 TOP: Locus

469 ANS:

$$V = \pi r^2 h = \pi(5)^2 \cdot 7 = 175\pi$$

PTS: 2 REF: 081231ge STA: G.G.14 TOP: Volume

470 ANS:

$$y = \frac{2}{3}x - 9. \text{ The slope of } 2x - 3y = 11 \text{ is } -\frac{A}{B} = \frac{-2}{-3} = \frac{2}{3}. -5 = \left(\frac{2}{3}\right)(6) + b$$

$$-5 = 4 + b$$

$$b = -9$$

PTS: 2 REF: 080931ge STA: G.G.65 TOP: Parallel and Perpendicular Lines

471 ANS:

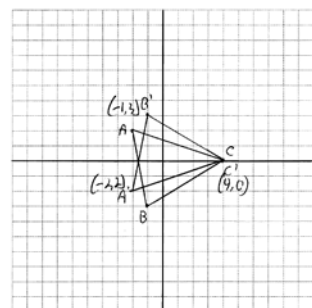
PTS: 2 REF: 011130ge STA: G.G.54 TOP: Reflections
KEY: grids

472 ANS:

$$4. \quad l_1 w_1 h_1 = l_2 w_2 h_2$$

$$10 \times 2 \times h = 5 \times w_2 \times h$$

$$20 = 5w_2$$

$$w_2 = 4$$

PTS: 2 REF: 011030ge STA: G.G.11 TOP: Volume

473 ANS:
 $A'(2,2), B'(3,0), C(1,-1)$

PTS: 2 REF: 081329ge STA: G.G.58 TOP: Dilations

474 ANS:

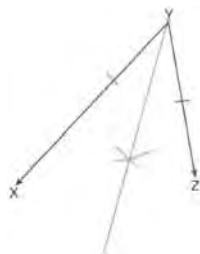

PTS: 2 REF: 011233ge STA: G.G.17 TOP: Constructions

475 ANS:

$$M = \left(\frac{3+3}{2}, \frac{-1+5}{2} \right) = (3, 2). \quad y = 2.$$

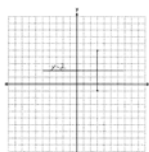

PTS: 2 REF: 011334ge STA: G.G.68 TOP: Perpendicular Bisector

476 ANS:

$$\sqrt{(7-3)^2 + (-8-0)^2} = \sqrt{16+64} = \sqrt{80} = 4\sqrt{5}$$

PTS: 2 REF: 061331ge STA: G.G.69 TOP: Triangles in the Coordinate Plane

477 ANS:

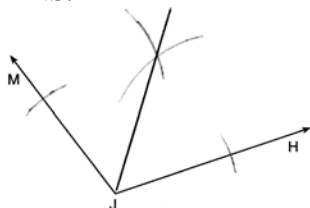

PTS: 2 REF: 081330ge STA: G.G.17 TOP: Constructions

478 ANS:

$$2016. \quad V = \frac{1}{3} Bh = \frac{1}{3} s^2 h = \frac{1}{3} 12^2 \cdot 42 = 2016$$

PTS: 2 REF: 080930ge STA: G.G.13 TOP: Volume

479 ANS:

$$y = -2x + 14. \quad \text{The slope of } 2x + y = 3 \text{ is } \frac{-A}{B} = \frac{-2}{1} = -2. \quad y = mx + b$$

$$4 = (-2)(5) + b$$

$$b = 14$$

PTS: 2 REF: 060931ge STA: G.G.65 TOP: Parallel and Perpendicular Lines

480 ANS:

$$\sqrt{(-1-3)^2 + (4-(-2))^2} = \sqrt{16+36} = \sqrt{52} = \sqrt{4} \sqrt{13} = 2\sqrt{13}$$

PTS: 2

REF: 081331ge

STA: G.G.67

TOP: Distance

481 ANS:

$$\sqrt{(-4-2)^2 + (3-5)^2} = \sqrt{36+4} = \sqrt{40} = \sqrt{4} \sqrt{10} = 2\sqrt{10}.$$

PTS: 2

REF: 081232ge

STA: G.G.67

TOP: Distance

482 ANS:

Distance is preserved after the reflection. $2x + 13 = 9x - 8$

$$21 = 7x$$

$$3 = x$$

PTS: 2

REF: 011329ge

STA: G.G.55

TOP: Properties of Transformations

483 ANS:

$$2\sqrt{3} \cdot x^2 = 3 \cdot 4$$

$$x = \sqrt{12} = 2\sqrt{3}$$

PTS: 2

REF: fall0829ge

STA: G.G.47

TOP: Similarity

KEY: altitude

484 ANS:

 $\angle ACB \cong \angle AED$ is given. $\angle A \cong \angle A$ because of the reflexive property. Therefore $\triangle ABC \sim \triangle ADE$ because of AA.

PTS: 2

REF: 081133ge

STA: G.G.44

TOP: Similarity Proofs

485 ANS:

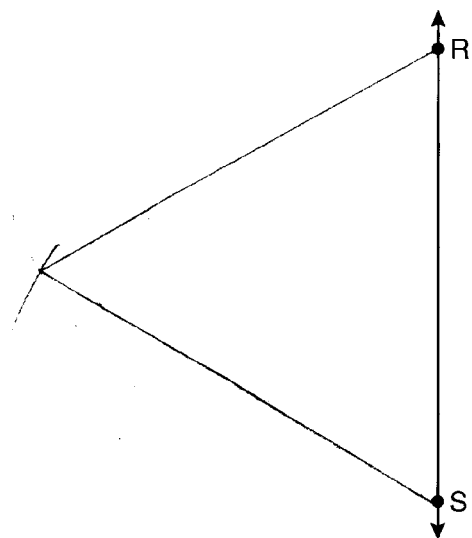

PTS: 2

REF: 061130ge

STA: G.G.20

TOP: Constructions

486 ANS:
 $R'(-3, -2)$, $S'(-4, 4)$, and $T'(2, 2)$.

PTS: 2 REF: 011232ge STA: G.G.54 TOP: Rotations

487 ANS:

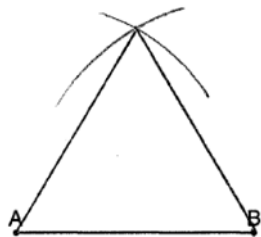

PTS: 2 REF: 011032ge STA: G.G.20 TOP: Constructions

488 ANS:

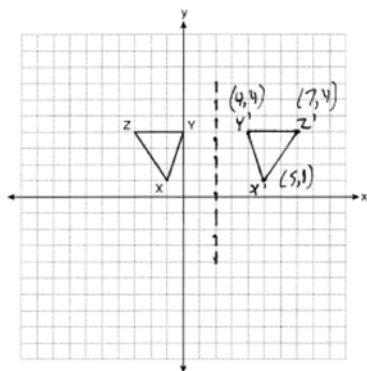

PTS: 2 REF: 061032ge STA: G.G.54 TOP: Reflections

KEY: grids

489 ANS:

3. The non-parallel sides of an isosceles trapezoid are congruent. $2x + 5 = 3x + 2$
 $x = 3$

PTS: 2 REF: 080929ge STA: G.G.40 TOP: Trapezoids

490 ANS:

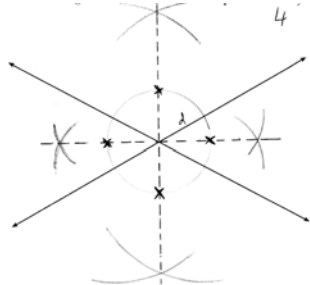

PTS: 2 REF: 081334ge STA: G.G.22 TOP: Locus

491 ANS:

True. The first statement is true and the second statement is false. In a disjunction, if either statement is true, the disjunction is true.

PTS: 2

REF: 060933ge

STA: G.G.25

TOP: Compound Statements

KEY: disjunction

492 ANS:

$$70. 3x + 5 + 3x + 5 + 2x + 2x = 180$$

$$10x + 10 = 360$$

$$10x = 350$$

$$x = 35$$

$$2x = 70$$

PTS: 2

REF: 081029ge

STA: G.G.40

TOP: Trapezoids

493 ANS:

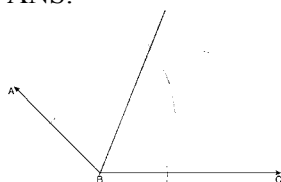

PTS: 2

REF: 011133ge

STA: G.G.17

TOP: Constructions

494 ANS:

$$\frac{180 - 80}{2} = 50$$

PTS: 2

REF: 081129ge

STA: G.G.52

TOP: Chords

495 ANS:

Contrapositive-If two angles of a triangle are not congruent, the sides opposite those angles are not congruent.

PTS: 2

REF: fall0834ge

STA: G.G.26

TOP: Conditional Statements

496 ANS:

$$(2a - 3, 3b + 2) \cdot \left(\frac{3a + a - 6}{2}, \frac{2b - 1 + 4b + 5}{2} \right) = \left(\frac{4a - 6}{2}, \frac{6b + 4}{2} \right) = (2a - 3, 3b + 2)$$

PTS: 2

REF: 061134ge

STA: G.G.66

TOP: Midpoint

497 ANS:

$$A = 2B - 15 \quad . \quad 2B - 15 + B + 2B - 15 + B = 180$$

$$C = A + B$$

$$6B - 30 = 180$$

$$C = 2B - 15 + B$$

$$6B = 210$$

$$B = 35$$

PTS: 2

REF: 081332ge

STA: G.G.30

TOP: Interior and Exterior Angles of Triangles

498 ANS:

$$34. 2x - 12 + x + 90 = 180$$

$$3x + 78 = 90$$

$$3x = 102$$

$$x = 34$$

PTS: 2 REF: 061031ge STA: G.G.30 TOP: Interior and Exterior Angles of Triangles

499 ANS:

Yes. A reflection is an isometry.

PTS: 2 REF: 061132ge STA: G.G.56 TOP: Identifying Transformations

500 ANS:

$$(5 - 2)180 = 540. \frac{540}{5} = 108 \text{ interior. } 180 - 108 = 72 \text{ exterior}$$

PTS: 2 REF: 011131ge STA: G.G.37 TOP: Interior and Exterior Angles of Polygons

501 ANS:

$$L = 2\pi rh = 2\pi \cdot 12 \cdot 22 \approx 1659. \frac{1659}{600} \approx 2.8. \text{ 3 cans are needed.}$$

PTS: 2 REF: 061233ge STA: G.G.14 TOP: Lateral Area

502 ANS:

$$(6, -4). C_x = \frac{Q_x + R_x}{2}. C_y = \frac{Q_y + R_y}{2}.$$

$$3.5 = \frac{1 + R_x}{2} \quad 2 = \frac{8 + R_y}{2}$$

$$7 = 1 + R_x \quad 4 = 8 + R_y$$

$$6 = R_x \quad -4 = R_y$$

PTS: 2 REF: 011031ge STA: G.G.66 TOP: Midpoint

KEY: graph

503 ANS:

$$22.4. \quad V = \pi r^2 h$$

$$12566.4 = \pi r^2 \cdot 8$$

$$r^2 = \frac{12566.4}{8\pi}$$

$$r \approx 22.4$$

PTS: 2 REF: fall0833ge STA: G.G.14 TOP: Volume

504 ANS:

$$20. 5x + 10 = 4x + 30$$

$$x = 20$$

PTS: 2

REF: 060934ge

STA: G.G.45

TOP: Similarity

KEY: basic

505 ANS:

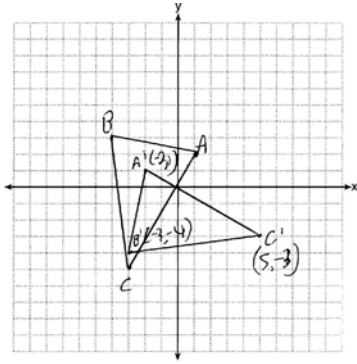

$A'(-2, 1)$, $B'(-3, -4)$, and $C'(5, -3)$

PTS: 2

REF: 081230ge

STA: G.G.54

TOP: Rotations

506 ANS:

\overline{AC} . $m\angle BCA = 63$ and $m\angle ABC = 80$. \overline{AC} is the longest side as it is opposite the largest angle.

PTS: 2

REF: 080934ge

STA: G.G.34

TOP: Angle Side Relationship

507 ANS:

$$26. x + 3x + 5x - 54 = 180$$

$$9x = 234$$

$$x = 26$$

PTS: 2

REF: 080933ge

STA: G.G.30

TOP: Interior and Exterior Angles of Triangles

508 ANS:

$$(n - 2)180 = (8 - 2)180 = 1080. \frac{1080}{8} = 135.$$

PTS: 2

REF: 061330ge

STA: G.G.37

TOP: Interior and Exterior Angles of Polygons

509 ANS:

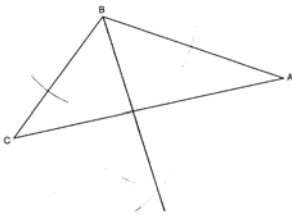

PTS: 2

REF: 061232ge

STA: G.G.17

TOP: Constructions

510 ANS:

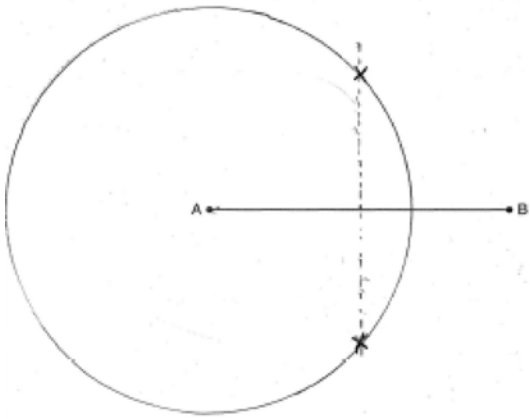

PTS: 2

REF: 060932ge

STA: G.G.22

TOP: Locus

Geometry 4 Point Regents Exam Questions Answer Section

511 ANS:

$$2(y + 10) = 4y - 20. \quad \overline{DF} = y + 10 = 20 + 10 = 30. \quad \overline{OA} = \overline{OD} = \sqrt{16^2 + 30^2} = 34$$

$$2y + 20 = 4y - 20$$

$$40 = 2y$$

$$20 = y$$

PTS: 4

REF: 061336ge

STA: G.G.49

TOP: Chords

512 ANS:

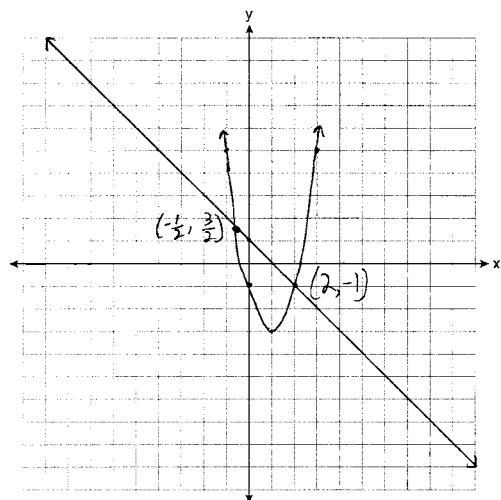

PTS: 4

REF: 061137ge

STA: G.G.70

TOP: Quadratic-Linear Systems

513 ANS:

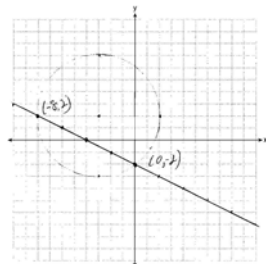

PTS: 4

REF: 081237ge

STA: G.G.70

TOP: Quadratic-Linear Systems

514 ANS:

$$2 \quad \frac{x+2}{x} = \frac{x+6}{4}$$

$$x^2 + 6x = 4x + 8$$

$$x^2 + 2x - 8 = 0$$

$$(x+4)(x-2) = 0$$

$$x = 2$$

PTS: 4

REF: 081137ge

STA: G.G.45

TOP: Similarity

KEY: basic

515 ANS:

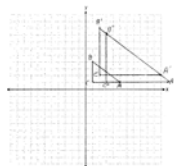
 $A''(11, 1), B''(3, 7), C''(3, 1)$

PTS: 4

REF: 011336ge

STA: G.G.58

TOP: Compositions of Transformations

516 ANS:

$\angle D, \angle G$ and 24° or $\angle E, \angle F$ and 84° . $m\widehat{FE} = \frac{2}{15} \times 360 = 48$. Since the chords forming $\angle D$ and $\angle G$ are intercepted by \widehat{FE} , their measure is 24° . $m\widehat{GD} = \frac{7}{15} \times 360 = 168$. Since the chords forming $\angle E$ and $\angle F$ are intercepted by \widehat{GD} , their measure is 84° .

PTS: 4

REF: fall0836ge

STA: G.G.51

TOP: Arcs Determined by Angles

KEY: inscribed

517 ANS:

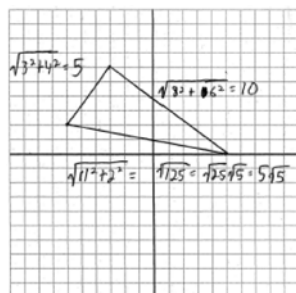

$$15 + 5\sqrt{5}$$

PTS: 4

REF: 060936ge

STA: G.G.69

TOP: Triangles in the Coordinate Plane

518 ANS:

Yes, $m\angle ABD = m\angle BDC = 44$ $180 - (93 + 43) = 44$ $x + 19 + 2x + 6 + 3x + 5 = 180$. Because alternate interior

$$6x + 30 = 180$$

$$6x = 150$$

$$x = 25$$

$$x + 19 = 44$$

angles $\angle ABD$ and $\angle CDB$ are congruent, \overline{AB} is parallel to \overline{DC} .

PTS: 4

REF: 081035ge

STA: G.G.35

TOP: Parallel Lines and Transversals

519 ANS:

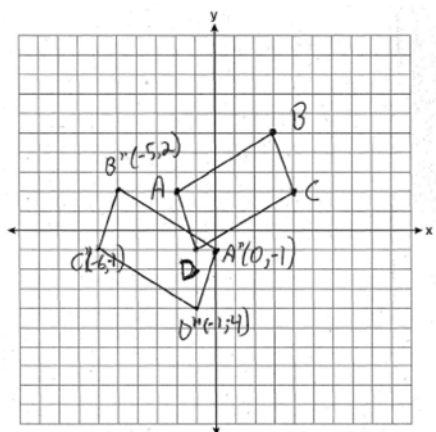

PTS: 4

REF: 060937ge

STA: G.G.54

TOP: Compositions of Transformations

KEY: grids

520 ANS:

$$2.4. \quad 5a = 4^2 \quad 5b = 3^2 \quad h^2 = ab$$

$$a = 3.2 \quad b = 1.8 \quad h^2 = 3.2 \cdot 1.8$$

$$h = \sqrt{5.76} = 2.4$$

PTS: 4

REF: 081037ge

STA: G.G.47

TOP: Similarity

KEY: altitude

521 ANS:

$$\text{Midpoint: } \left(\frac{-4+4}{2}, \frac{2+(-4)}{2} \right) = (0, -1). \text{ Distance: } d = \sqrt{(-4-4)^2 + (2-(-4))^2} = \sqrt{100} = 10$$

$$r = 5$$

$$r^2 = 25$$

$$x^2 + (y+1)^2 = 25$$

PTS: 4

REF: 061037ge

STA: G.G.71

TOP: Equations of Circles

522 ANS:

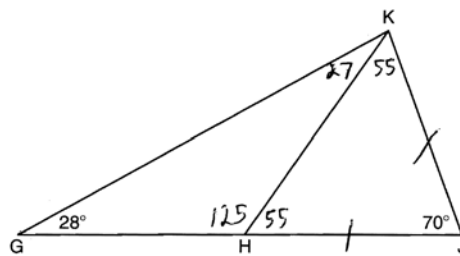

No, $\angle KGH$ is not congruent to $\angle GKH$.

PTS: 2 REF: 081135ge STA: G.G.31 TOP: Isosceles Triangle Theorem

523 ANS:

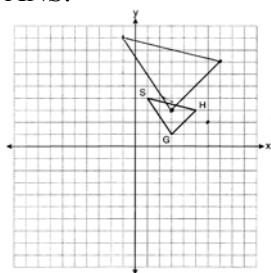

$G''(3,3), H''(7,7), S''(-1,9)$

PTS: 4 REF: 081136ge STA: G.G.58 TOP: Compositions of Transformations

524 ANS:

$\overline{BD} \cong \overline{DB}$ (Reflexive Property); $\triangle ABD \cong \triangle CDB$ (SSS); $\angle BDC \cong \angle ABD$ (CPCTC).

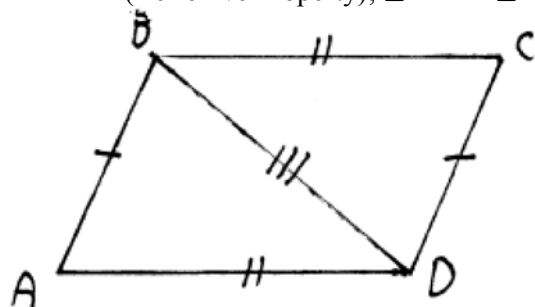

PTS: 4 REF: 061035ge STA: G.G.27 TOP: Quadrilateral Proofs

525 ANS:

11. $x^2 + 6x = x + 14$. $6(2) - 1 = 11$

$$x^2 + 5x - 14 = 0$$

$$(x + 7)(x - 2) = 0$$

$$x = 2$$

PTS: 2 REF: 081235ge STA: G.G.38 TOP: Parallelograms

526 ANS:

$$V = \pi r^2 h \quad L = 2\pi r h = 2\pi \cdot 5\sqrt{2} \cdot 12 \approx 533.1$$

$$600\pi = \pi r^2 \cdot 12$$

$$50 = r^2$$

$$\sqrt{25} \sqrt{2} = r$$

$$5\sqrt{2} = r$$

PTS: 4 REF: 011236ge STA: G.G.14 TOP: Volume

527 ANS:

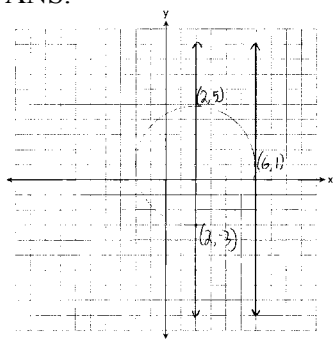

PTS: 4 REF: 011135ge STA: G.G.23 TOP: Locus

528 ANS:

$$y = \frac{2}{3}x + 1 \quad 2y + 3x = 6 \quad y = mx + b$$

$$2y = -3x + 6 \quad 5 = \frac{2}{3}(6) + b$$

$$y = -\frac{3}{2}x + 3 \quad 5 = 4 + b$$

$$m = -\frac{3}{2} \quad 1 = b$$

$$m_{\perp} = \frac{2}{3} \quad y = \frac{2}{3}x + 1$$

PTS: 4 REF: 061036ge STA: G.G.64 TOP: Parallel and Perpendicular Lines

529 ANS:

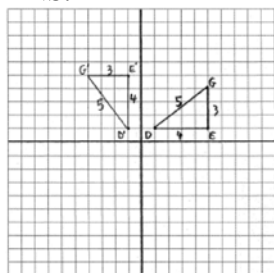

$D'(-1, 1), E'(-1, 5), G'(-4, 5)$

PTS: 4 REF: 080937ge STA: G.G.55 TOP: Properties of Transformations

530 ANS:

$$12x - 4 + 180 - 6x + 6x + 7x + 13 = 360. \quad 16y + 1 = \frac{12y + 1 + 18y + 6}{2}$$

$$19x + 189 = 360 \quad 32y + 2 = 30y + 7$$

$$19x = 171 \quad 2y = 5$$

$$x = 9 \quad y = \frac{5}{2}$$

PTS: 4 REF: 081337ge STA: G.G.40 TOP: Trapezoids

531 ANS:

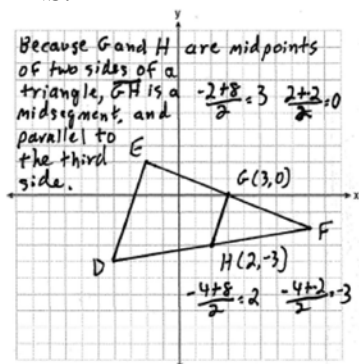

PTS: 4 REF: fall0835ge STA: G.G.42 TOP: Midsegments

532 ANS:

$\overline{JK} \cong \overline{LM}$ because opposite sides of a parallelogram are congruent. $\overline{LM} \cong \overline{LN}$ because of the Isosceles Triangle Theorem. $\overline{LM} \cong \overline{JM}$ because of the transitive property. $JKLM$ is a rhombus because all sides are congruent.

PTS: 4 REF: 011036ge STA: G.G.41 TOP: Special Quadrilaterals

533 ANS:

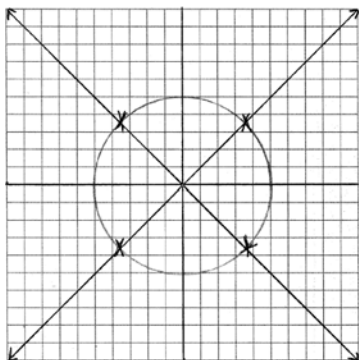

PTS: 4 REF: 011037ge STA: G.G.23 TOP: Locus

534 ANS:

$$x^2 - 8x = 5x + 30. \quad m\angle C = 4(15) - 5 = 55$$

$$x^2 - 13x - 30 = 0$$

$$(x - 15)(x + 2) = 0$$

$$x = 15$$

PTS: 4

REF: 061337ge

STA: G.G.45

TOP: Similarity

KEY: basic

535 ANS:

18. If the ratio of TA to AC is 1:3, the ratio of TE to ES is also 1:3. $x + 3x = 24. \quad 3(6) = 18.$

$$x = 6$$

PTS: 4

REF: 060935ge

STA: G.G.50

TOP: Tangents

KEY: common tangency

536 ANS:

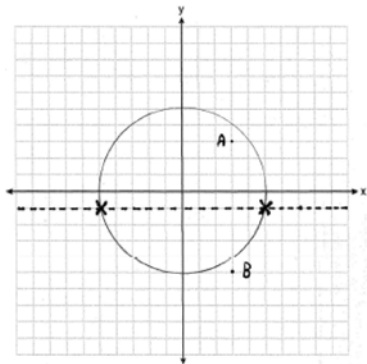

PTS: 4

REF: fall0837ge

STA: G.G.23

TOP: Locus

537 ANS:

$$32. \quad \frac{16}{20} = \frac{x-3}{x+5} \quad \cdot \overline{AC} = x - 3 = 35 - 3 = 32$$

$$16x + 80 = 20x - 60$$

$$140 = 4x$$

$$35 = x$$

PTS: 4

REF: 011137ge

STA: G.G.46

TOP: Side Splitter Theorem

538 ANS:

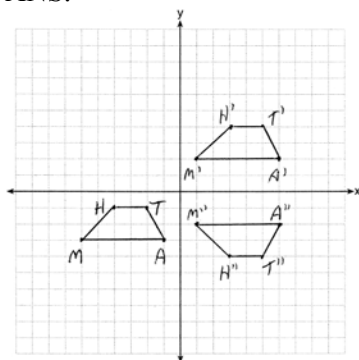
 $M''(1, -2), A''(6, -2), T''(5, -4), H''(3, -4)$

PTS: 4 REF: 081336ge STA: G.G.58 TOP: Compositions of Transformations

KEY: grids

539 ANS:

$\angle B$ and $\angle E$ are right angles because of the definition of perpendicular lines. $\angle B \cong \angle E$ because all right angles are congruent. $\angle BFD$ and $\angle DFE$ are supplementary and $\angle ECA$ and $\angle ACB$ are supplementary because of the definition of supplementary angles. $\angle DFE \cong \angle ACB$ because angles supplementary to congruent angles are congruent. $\triangle ABC \sim \triangle DEF$ because of AA.

PTS: 4 REF: 011136ge STA: G.G.44 TOP: Similarity Proofs

540 ANS:

$\angle B$ and $\angle C$ are right angles because perpendicular lines form right angles. $\angle B \cong \angle C$ because all right angles are congruent. $\angle AEB \cong \angle DEC$ because vertical angles are congruent. $\triangle ABE \cong \triangle DCE$ because of ASA. $\overline{AB} \cong \overline{DC}$ because CPCTC.

PTS: 4 REF: 061235ge STA: G.G.27 TOP: Triangle Proofs

541 ANS:

$x^2 + 12 + 11x + 5 + 13x - 17 = 180$. $m\angle A = 6^2 + 12 = 48$. $\angle B$ is the largest angle, so \overline{AC} is the longest side.

$$x^2 + 24x - 180 = 0 \quad m\angle B = 11(6) + 5 = 71$$

$$(x + 30)(x - 6) = 0 \quad m\angle C = 13(6) - 7 = 61$$

$$x = 6$$

PTS: 4 REF: 011337ge STA: G.G.34 TOP: Angle Side Relationship

542 ANS:

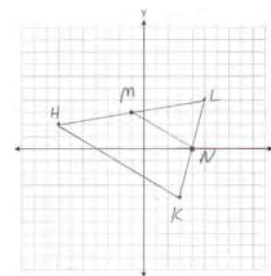

$M\left(\frac{-7+3}{2}, \frac{3+5}{2}\right) = M(-1, 3)$. $N\left(\frac{3+3}{2}, \frac{5+1}{2}\right) = N(3, 3)$. \overline{MN} is a midsegment.

PTS: 4 REF: 011237ge STA: G.G.42 TOP: Midsegments

543 ANS:

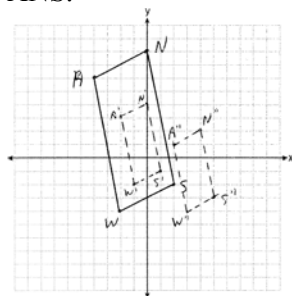

$S''(5, -3)$, $W''(3, -4)$, $A''(2, 1)$, and $N''(4, 2)$

PTS: 4 REF: 061335ge STA: G.G.58 TOP: Compositions of Transformations

KEY: grids

544 ANS:

$$L = 2\pi rh = 2\pi \cdot 3 \cdot 5 \approx 94.25. \quad V = \pi r^2 h = \pi(3)^2(5) \approx 141.37$$

PTS: 4 REF: 011335ge STA: G.G.14 TOP: Volume

545 ANS:

$\triangle ABC$, \overline{BD} bisects $\angle ABC$, $\overline{BD} \perp \overline{AC}$ (Given). $\angle CBD \cong \angle ABD$ (Definition of angle bisector). $\overline{BD} \cong \overline{BD}$ (Reflexive property). $\angle CDB$ and $\angle ADB$ are right angles (Definition of perpendicular). $\angle CDB \cong \angle ADB$ (All right angles are congruent). $\triangle CDB \cong \triangle ADB$ (SAS). $\overline{AB} \cong \overline{CB}$ (CPCTC).

PTS: 4 REF: 081335ge STA: G.G.27 TOP: Triangle Proofs

546 ANS:

36, because a dilation does not affect angle measure. 10, because a dilation does affect distance.

PTS: 4 REF: 011035ge STA: G.G.59 TOP: Properties of Transformations

547 ANS:

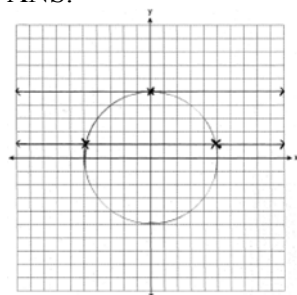

PTS: 4 REF: 080936ge STA: G.G.23 TOP: Locus

548 ANS:

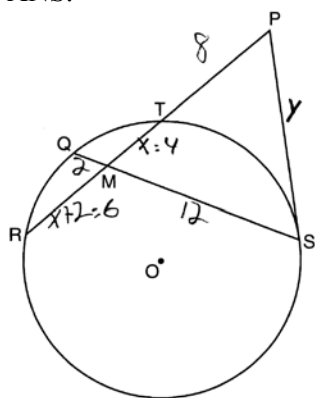

$$x(x+2) = 12 \cdot 2. \quad \overline{RT} = 6+4 = 10. \quad y \cdot y = 18 \cdot 8$$

$$x^2 + 2x - 24 = 0$$

$$y^2 = 144$$

$$(x+6)(x-4) = 0$$

$$y = 12$$

$$x = 4$$

PTS: 4

REF: 061237ge

STA: G.G.53

TOP: Segments Intercepted by Circle

KEY: tangent and secant

549 ANS:

$$y = \frac{4}{3}x - 6. \quad M_x = \frac{-1+7}{2} = 3 \quad \text{The perpendicular bisector goes through } (3, -2) \text{ and has a slope of } \frac{4}{3}.$$

$$M_y = \frac{1+(-5)}{2} = -2$$

$$m = \frac{1-(-5)}{-1-7} = -\frac{3}{4}$$

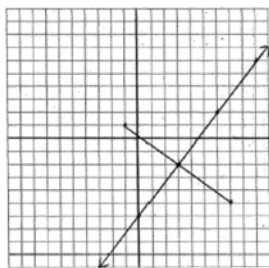

$$y - y_M = m(x - x_M).$$

$$y - 1 = \frac{4}{3}(x - 2)$$

PTS: 4

REF: 080935ge

STA: G.G.68

TOP: Perpendicular Bisector

550 ANS:

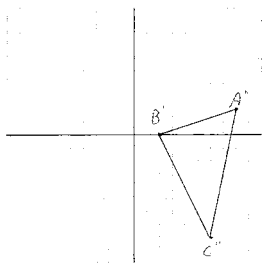

$A''(8,2), B''(2,0), C''(6,-8)$

PTS: 4 REF: 081036ge STA: G.G.58 TOP: Compositions of Transformations

551 ANS:

30. $3x + 4x + 5x = 360$. $m\widehat{LN} : m\widehat{NK} : m\widehat{KL} = 90 : 120 : 150$. $\frac{150 - 90}{2} = 30$
 $x = 20$

PTS: 4 REF: 061136ge STA: G.G.51 TOP: Arcs Determined by Angles
 KEY: outside circle

552 ANS:

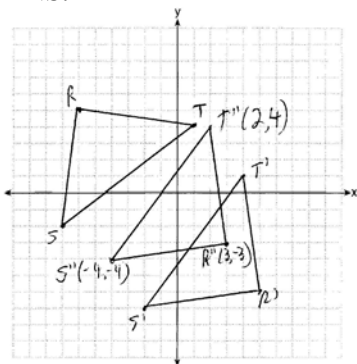

PTS: 4 REF: 081236ge STA: G.G.58 TOP: Compositions of Transformations
 KEY: grids

553 ANS:

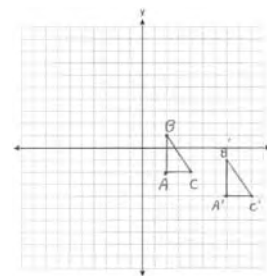

$A'(7,-4), B'(7,-1), C'(9,-4)$. The areas are equal because translations preserve distance.

PTS: 4 REF: 011235ge STA: G.G.55 TOP: Properties of Transformations

554 ANS:

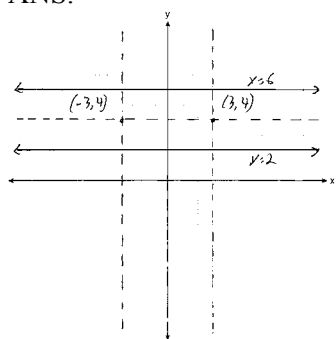

PTS: 4

REF: 061135ge

STA: G.G.23

TOP: Locus

555 ANS:

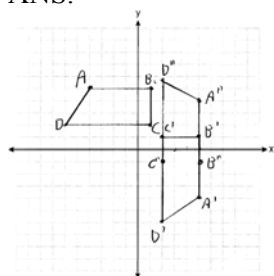

$A'(5, -4), B'(5, 1), C'(2, 1), D'(2, -6); A''(5, 4), B''(5, -1), C''(2, -1), D''(2, 6)$

PTS: 4

REF: 061236ge

STA: G.G.58

TOP: Compositions of Transformations

KEY: grids

Geometry 6 Point Regents Exam Questions Answer Section

556 ANS:

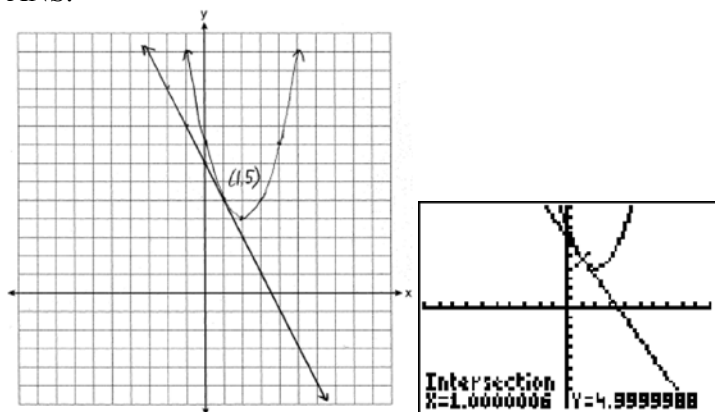

PTS: 6

REF: 011038ge

STA: G.G.70

TOP: Quadratic-Linear Systems

557 ANS:

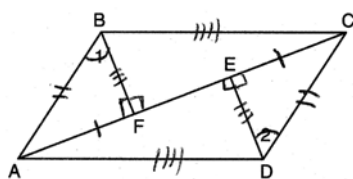

$\overline{FE} \cong \overline{FE}$ (Reflexive Property); $\overline{AE} - \overline{FE} \cong \overline{FC} - \overline{FE}$ (Line Segment Subtraction Theorem); $\overline{AF} \cong \overline{CE}$ (Substitution); $\angle BFA \cong \angle DEG$ (All right angles are congruent); $\triangle BFA \cong \triangle DEG$ (AAS); $\overline{AB} \cong \overline{CD}$ and $\overline{BF} \cong \overline{DG}$ (CPCTC); $\angle BFC \cong \angle DGA$ (All right angles are congruent); $\triangle BFC \cong \triangle DGA$ (SAS); $\overline{AD} \cong \overline{BC}$ (CPCTC); $ABCD$ is a parallelogram (opposite sides of quadrilateral $ABCD$ are congruent)

PTS: 6

REF: 080938ge

STA: G.G.41

TOP: Special Quadrilaterals

558 ANS:

$\overline{AC} \cong \overline{EC}$ and $\overline{DC} \cong \overline{BC}$ because of the definition of midpoint. $\angle ACB \cong \angle ECD$ because of vertical angles. $\triangle ABC \cong \triangle EDC$ because of SAS. $\angle CDE \cong \angle CBA$ because of CPCTC. BD is a transversal intersecting \overline{AB} and

\overline{ED} . Therefore $\overline{AB} \parallel \overline{DE}$ because $\angle CDE$ and $\angle CBA$ are congruent alternate interior angles.

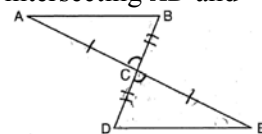

PTS: 6

REF: 060938ge

STA: G.G.27

TOP: Triangle Proofs

559 ANS:

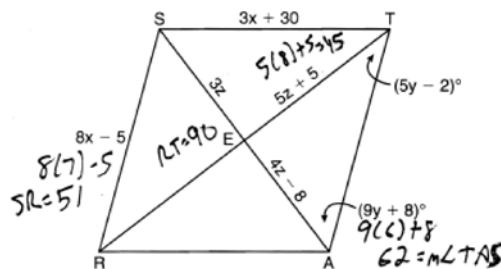

$$8x - 5 = 3x + 30. \quad 4z - 8 = 3z. \quad 9y + 8 + 5y - 2 = 90.$$

$$5x = 35 \qquad z = 8 \qquad 14y + 6 = 90$$

$$x = 7 \qquad \qquad \qquad 14y = 84$$

$$y = 6$$

PTS: 6 REF: 061038ge STA: G.G.39 TOP: Special Parallelograms

560 ANS:

$$52, 40, 80. \quad 360 - (56 + 112) = 192. \quad \frac{192 - 112}{2} = 40. \quad \frac{112 + 48}{2} = 80$$

$$\frac{1}{4} \times 192 = 48$$

$$\frac{56 + 48}{2} = 52$$

PTS: 6 REF: 081238ge STA: G.G.51 TOP: Arcs Determined by Angles

KEY: mixed

561 ANS:

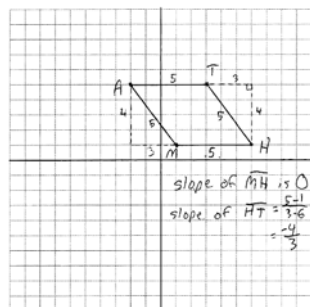

The length of each side of quadrilateral is 5. Since each side is congruent, quadrilateral $MATH$ is a rhombus. The slope of \overline{MH} is 0 and the slope of \overline{HT} is $-\frac{4}{5}$. Since the slopes are not negative reciprocals, the sides are not perpendicular and do not form right angles. Since adjacent sides are not perpendicular, quadrilateral $MATH$ is not a square.

PTS: 6 REF: 011138ge STA: G.G.69 TOP: Quadrilaterals in the Coordinate Plane

562 ANS:

Quadrilateral $ABCD$, $\overline{AD} \cong \overline{BC}$ and $\angle DAE \cong \angle BCE$ are given. $\overline{AD} \parallel \overline{BC}$ because if two lines are cut by a transversal so that a pair of alternate interior angles are congruent, the lines are parallel. $ABCD$ is a parallelogram because if one pair of opposite sides of a quadrilateral are both congruent and parallel, the quadrilateral is a parallelogram. $\overline{AE} \cong \overline{CE}$ because the diagonals of a parallelogram bisect each other. $\angle FEA \cong \angle GEC$ as vertical angles. $\triangle AEF \cong \triangle CEG$ by ASA.

PTS: 6 REF: 011238ge STA: G.G.27 TOP: Quadrilateral Proofs

563 ANS:

$$M\left(\frac{-7+3}{2}, \frac{4+6}{2}\right) = M(-5, 5) \cdot m_{\overline{MN}} = \frac{5-3}{-5-0} = \frac{2}{-5} \cdot \text{Since both opposite sides have equal slopes and are}$$

$$N\left(\frac{-3+3}{2}, \frac{6+0}{2}\right) = N(0, 3) \quad m_{\overline{PQ}} = \frac{-4-2}{2-3} = \frac{-2}{-1} = 2$$

$$P\left(\frac{3+1}{2}, \frac{0+8}{2}\right) = P(2, 4) \quad m_{\overline{NA}} = \frac{3-4}{0-2} = \frac{-1}{-2} = \frac{1}{2}$$

$$Q\left(\frac{-7+1}{2}, \frac{4+8}{2}\right) = Q(-3, 6) \quad m_{\overline{QM}} = \frac{-2-5}{-3-5} = \frac{-7}{-8} = \frac{7}{8}$$

parallel, $MNPQ$ is a parallelogram. $\overline{MN} = \sqrt{(-5-0)^2 + (5-3)^2} = \sqrt{29}$. \overline{MN} is not congruent to \overline{NP} , so $MNPQ$

$$\overline{NA} = \sqrt{(0-2)^2 + (3-4)^2} = \sqrt{5}$$

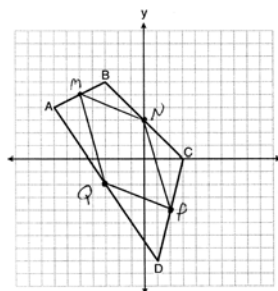

is not a rhombus since not all sides are congruent.

PTS: 6 REF: 081338ge STA: G.G.69 TOP: Quadrilaterals in the Coordinate Plane

564 ANS:

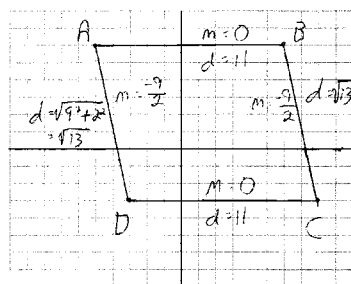

$\overline{AB} \parallel \overline{CD}$ and $\overline{AD} \parallel \overline{BC}$ because their slopes are equal. $ABCD$ is a parallelogram

because opposite side are parallel. $\overline{AB} \neq \overline{BC}$. $ABCD$ is not a rhombus because all sides are not equal. $\overline{AB} \sim \perp \overline{BC}$ because their slopes are not opposite reciprocals. $ABCD$ is not a rectangle because $\angle ABC$ is not a right angle.

PTS: 4 REF: 081038ge STA: G.G.69 TOP: Quadrilaterals in the Coordinate Plane

565 ANS:

$\overline{OA} \cong \overline{OB}$ because all radii are equal. $\overline{OP} \cong \overline{OP}$ because of the reflexive property. $\overline{OA} \perp \overline{PA}$ and $\overline{OB} \perp \overline{PB}$ because tangents to a circle are perpendicular to a radius at a point on a circle. $\angle PAO$ and $\angle PBO$ are right angles because of the definition of perpendicular. $\angle PAO \cong \angle PBO$ because all right angles are congruent. $\triangle AOP \cong \triangle BOP$ because of HL. $\angle AOP \cong \angle BOP$ because of CPCTC.

PTS: 6 REF: 061138ge STA: G.G.27 TOP: Circle Proofs

566 ANS:

Because $\overline{AB} \parallel \overline{DC}$, $\widehat{AD} \cong \widehat{BC}$ since parallel chords intersect congruent arcs. $\angle BDC \cong \angle ACD$ because inscribed angles that intercept congruent arcs are congruent. $\overline{AD} \cong \overline{BC}$ since congruent chords intersect congruent arcs. $\overline{DC} \cong \overline{CD}$ because of the reflexive property. Therefore, $\triangle ACD \cong \triangle BDC$ because of SAS.

PTS: 6 REF: fall0838ge STA: G.G.27 TOP: Circle Proofs

567 ANS:

Rectangle $ABCD$ with points E and F on side \overline{AB} , segments \overline{CE} and \overline{DF} intersect at G , and $\angle ADG \cong \angle BCE$ are given. $\overline{AD} \cong \overline{BC}$ because opposite sides of a rectangle are congruent. $\angle A$ and $\angle B$ are right angles and congruent because all angles of a rectangle are right and congruent. $\triangle ADF \cong \triangle BCE$ by ASA. $\overline{AF} \cong \overline{BE}$ per CPCTC. $\overline{EF} \cong \overline{FE}$ under the Reflexive Property. $\overline{AF} - \overline{EF} \cong \overline{BE} - \overline{FE}$ using the Subtraction Property of Segments. $\overline{AE} \cong \overline{BF}$ because of the Definition of Segments.

PTS: 6 REF: 011338ge STA: G.G.27 TOP: Quadrilateral Proofs

568 ANS:

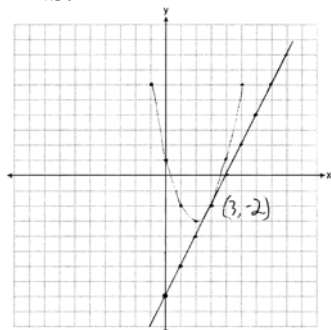

PTS: 6 REF: 061238ge STA: G.G.70 TOP: Quadratic-Linear Systems

569 ANS:

$\triangle MAH$, $\overline{MH} \cong \overline{AH}$ and medians \overline{AB} and \overline{MT} are given. $\overline{MA} \cong \overline{AM}$ (reflexive property). $\triangle MAH$ is an isosceles triangle (definition of isosceles triangle). $\angle AMB \cong \angle MAT$ (isosceles triangle theorem). B is the midpoint of \overline{MH} and T is the midpoint of \overline{AH} (definition of median). $m\overline{MB} = \frac{1}{2} m\overline{MH}$ and $m\overline{AT} = \frac{1}{2} m\overline{AH}$ (definition of midpoint). $\overline{MB} \cong \overline{AT}$ (multiplication postulate). $\triangle MBA \cong \triangle ATM$ (SAS). $\angle MBA \cong \angle ATM$ (CPCTC).

PTS: 6 REF: 061338ge STA: G.G.27 TOP: Triangle Proofs

570 ANS:

$m_{\overline{AB}} = \left(\frac{-6+2}{2}, \frac{-2+8}{2} \right) = D(2,3)$ $m_{\overline{BC}} = \left(\frac{2+6}{2}, \frac{8+-2}{2} \right) = E(4,3)$ $F(0,-2)$. To prove that $ADEF$ is a parallelogram, show that both pairs of opposite sides of the parallelogram are parallel by showing the opposite sides have the same slope: $m_{\overline{AD}} = \frac{3--2}{-2--6} = \frac{5}{4}$ $\overline{AF} \parallel \overline{DE}$ because all horizontal lines have the same slope. $ADEF$

$$m_{\overline{FE}} = \frac{3--2}{4-0} = \frac{5}{4}$$

is not a rhombus because not all sides are congruent. $AD = \sqrt{5^2 + 4^2} = \sqrt{41}$ $AF = 6$

PTS: 6

REF: 081138ge

STA: G.G.69

TOP: Quadrilaterals in the Coordinate Plane