

JMAP

REGENTS BY TYPE

The NY Algebra 2/Trigonometry Regents Exams
Fall 2009-June 2013

www.jmap.org

Dear Sir

I have to acknowledge the receipt of your favor of May 14. in which you mention that you have finished the 6. first books of Euclid, plane trigonometry, surveying & algebra and ask whether I think a further pursuit of that branch of science would be useful to you. there are some propositions in the latter books of Euclid, & some of Archimedes, which are useful, & I have no doubt you have been made acquainted with them. trigonometry, so far as this, is most valuable to every man, there is scarcely a day in which he will not resort to it for some of the purposes of common life. the science of calculation also is indispensable as far as the extraction of the square & cube roots; Algebra as far as the quadratic equation & the use of logarithms are often of value in ordinary cases: but all beyond these is but a luxury; a delicious luxury indeed; but not to be indulged in by one who is to have a profession to follow for his subsistence. in this light I view the conic sections, curves of the higher orders, perhaps even spherical trigonometry, Algebraical operations beyond the 2d dimension, and fluxions.

Letter from Thomas Jefferson to William G. Munford, Monticello, June 18, 1799.

Algebra 2/Trigonometry Multiple Choice Regents Exam Questions

1 The relationship between t , a student's test scores, and d , the student's success in college, is modeled by the equation $d = 0.48t + 75.2$. Based on this linear regression model, the correlation coefficient could be

- 1) between -1 and 0
- 2) between 0 and 1
- 3) equal to -1
- 4) equal to 0

2 Which formula can be used to determine the total number of different eight-letter arrangements that can be formed using the letters in the word *DEADLINE*?

- 1) $8!$
- 2) $\frac{8!}{4!}$
- 3) $\frac{8!}{2! + 2!}$
- 4) $\frac{8!}{2! \cdot 2!}$

3 The yearbook staff has designed a survey to learn student opinions on how the yearbook could be improved for this year. If they want to distribute this survey to 100 students and obtain the most reliable data, they should survey

- 1) every third student sent to the office
- 2) every third student to enter the library
- 3) every third student to enter the gym for the basketball game
- 4) every third student arriving at school in the morning

4 If a function is defined by the equation $f(x) = 4^x$, which graph represents the inverse of this function?

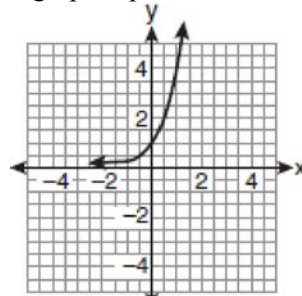

1)

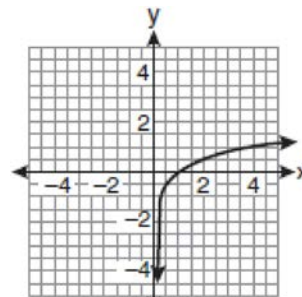

2)

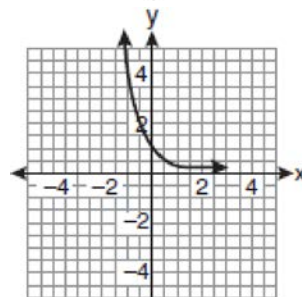

3)

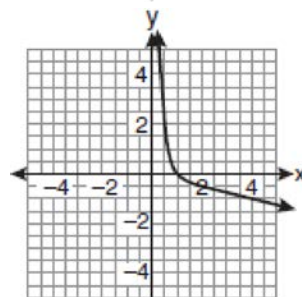

4)

Algebra 2/Trigonometry Multiple Choice Regents Exam Questions

www.jmap.org

- 5 The expression $2i^2 + 3i^3$ is equivalent to
- 1) $-2 - 3i$
 - 2) $2 - 3i$
 - 3) $-2 + 3i$
 - 4) $2 + 3i$
- 6 What is the solution set of the equation $3x^5 - 48x = 0$?
- 1) $\{0, \pm 2\}$
 - 2) $\{0, \pm 2, 3\}$
 - 3) $\{0, \pm 2, \pm 2i\}$
 - 4) $\{\pm 2, \pm 2i\}$
- 7 Expressed in simplest form, $\frac{3y}{2y-6} + \frac{9}{6-2y}$ is equivalent to
- 1) $\frac{-6y^2 + 36y - 54}{(2y-6)(6-2y)}$
 - 2) $\frac{3y-9}{2y-6}$
 - 3) $\frac{3}{2}$
 - 4) $-\frac{3}{2}$
- 8 The sum of the first eight terms of the series $3 - 12 + 48 - 192 + \dots$ is
- 1) $-13, 107$
 - 2) $-21, 845$
 - 3) $-39, 321$
 - 4) $-65, 535$
- 9 What is the radian measure of the smaller angle formed by the hands of a clock at 7 o'clock?
- 1) $\frac{\pi}{2}$
 - 2) $\frac{2\pi}{3}$
 - 3) $\frac{5\pi}{6}$
 - 4) $\frac{7\pi}{6}$
- 10 What is the fifteenth term of the sequence $5, -10, 20, -40, 80, \dots$?
- 1) $-163, 840$
 - 2) $-81, 920$
 - 3) $81, 920$
 - 4) $327, 680$
- 11 When $x^{-1} - 1$ is divided by $x - 1$, the quotient is
- 1) -1
 - 2) $-\frac{1}{x}$
 - 3) $\frac{1}{x^2}$
 - 4) $\frac{1}{(x-1)^2}$
- 12 The expression $(3 - 7i)^2$ is equivalent to
- 1) $-40 + 0i$
 - 2) $-40 - 42i$
 - 3) $58 + 0i$
 - 4) $58 - 42i$

Algebra 2/Trigonometry Multiple Choice Regents Exam Questions

www.jmap.org

- 13 A market research firm needs to collect data on viewer preferences for local news programming in Buffalo. Which method of data collection is most appropriate?
- 1) census
 - 2) survey
 - 3) observation
 - 4) controlled experiment

- 14 Which equation represents the graph below?

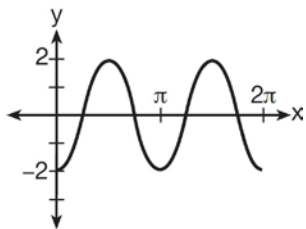

- 1) $y = -2 \sin 2x$
- 2) $y = -2 \sin \frac{1}{2}x$
- 3) $y = -2 \cos 2x$
- 4) $y = -2 \cos \frac{1}{2}x$

- 15 When factored completely, the expression

$$3x^3 - 5x^2 - 48x + 80$$

is equivalent to

- 1) $(x^2 - 16)(3x - 5)$
- 2) $(x^2 + 16)(3x - 5)(3x + 5)$
- 3) $(x + 4)(x - 4)(3x - 5)$
- 4) $(x + 4)(x - 4)(3x - 5)(3x - 5)$

- 16 What is the solution set for the equation

$$\sqrt{5x + 29} = x + 3?$$

- 1) $\{4\}$
- 2) $\{-5\}$
- 3) $\{4, 5\}$
- 4) $\{-5, 4\}$

- 17 Which is a graph of $y = \cot x$?

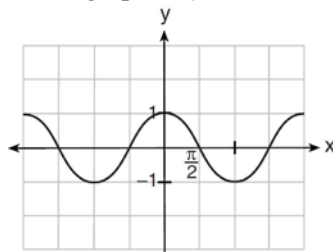

1)

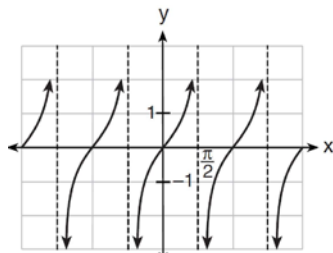

2)

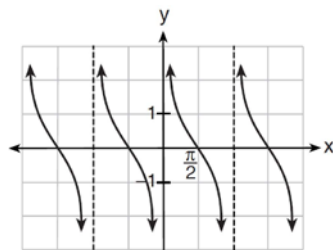

3)

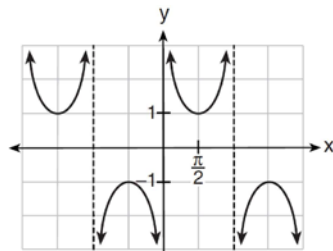

4)

Algebra 2/Trigonometry Multiple Choice Regents Exam Questions

www.jmap.org

18 Which function is *not* one-to-one?

- 1) $\{(0, 1), (1, 2), (2, 3), (3, 4)\}$
- 2) $\{(0, 0), (1, 1), (2, 2), (3, 3)\}$
- 3) $\{(0, 1), (1, 0), (2, 3), (3, 2)\}$
- 4) $\{(0, 1), (1, 0), (2, 0), (3, 2)\}$

19 What is the middle term in the expansion of

$$\left(\frac{x}{2} - 2y\right)^6?$$

- 1) $20x^3y^3$
- 2) $-\frac{15}{4}x^4y^2$
- 3) $-20x^3y^3$
- 4) $\frac{15}{4}x^4y^2$

20 The principal would like to assemble a committee of 8 students from the 15-member student council. How many different committees can be chosen?

- 1) 120
- 2) 6,435
- 3) 32,432,400
- 4) 259,459,200

21 When factored completely, $x^3 + 3x^2 - 4x - 12$ equals

- 1) $(x + 2)(x - 2)(x - 3)$
- 2) $(x + 2)(x - 2)(x + 3)$
- 3) $(x^2 - 4)(x + 3)$
- 4) $(x^2 - 4)(x - 3)$

22 What is the value of x in the equation

$$9^{3x+1} = 27^{x+2}?$$

- 1) 1
- 2) $\frac{1}{3}$
- 3) $\frac{1}{2}$
- 4) $\frac{4}{3}$

23 In $\triangle ABC$, $a = 15$, $b = 14$, and $c = 13$, as shown in the diagram below. What is the $m\angle C$, to the nearest degree?

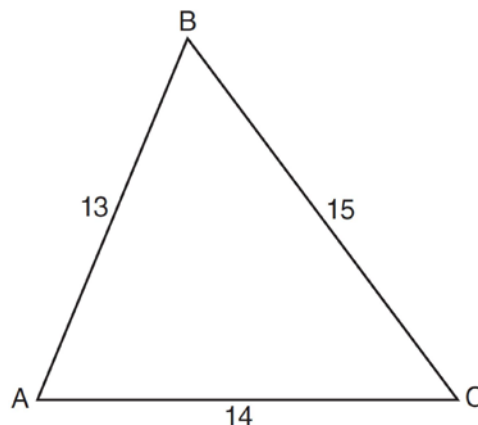

- 1) 53
- 2) 59
- 3) 67
- 4) 127

24 What is the common ratio of the geometric sequence shown below?

$$-2, 4, -8, 16, \dots$$

- 1) $-\frac{1}{2}$
- 2) 2
- 3) -2
- 4) -6

Algebra 2/Trigonometry Multiple Choice Regents Exam Questions

www.jmap.org

25 What is the common ratio of the geometric sequence whose first term is 27 and fourth term is 64?

- 1) $\frac{3}{4}$
- 2) $\frac{64}{81}$
- 3) $\frac{4}{3}$
- 4) $\frac{37}{3}$

26 Which graph represents the solution set of $|6x - 7| \leq 5$?

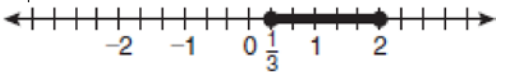
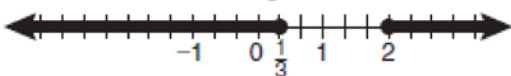
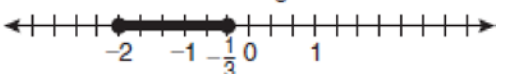
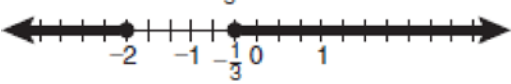
- 1) 
- 2) 
- 3) 
- 4) 

27 What is the fifteenth term of the geometric sequence $-\sqrt{5}, \sqrt{10}, -2\sqrt{5}, \dots$?

- 1) $-128\sqrt{5}$
- 2) $128\sqrt{10}$
- 3) $-16384\sqrt{5}$
- 4) $16384\sqrt{10}$

28 What is the common difference of the arithmetic sequence 5, 8, 11, 14?

- 1) $\frac{8}{5}$
- 2) -3
- 3) 3
- 4) 9

29 Which expression always equals 1?

- 1) $\cos^2 x - \sin^2 x$
- 2) $\cos^2 x + \sin^2 x$
- 3) $\cos x - \sin x$
- 4) $\cos x + \sin x$

30 What is the sum of the first 19 terms of the sequence 3, 10, 17, 24, 31, ...?

- 1) 1188
- 2) 1197
- 3) 1254
- 4) 1292

31 The expression $\log 4m^2$ is equivalent to

- 1) $2(\log 4 + \log m)$
- 2) $2 \log 4 + \log m$
- 3) $\log 4 + 2 \log n$
- 4) $\log 16 + 2 \log m$

32 Ms. Bell's mathematics class consists of 4 sophomores, 10 juniors, and 5 seniors. How many different ways can Ms. Bell create a four-member committee of juniors if each junior has an equal chance of being selected?

- 1) 210
- 2) 3,876
- 3) 5,040
- 4) 93,024

33 Factored completely, the expression

$12x^4 + 10x^3 - 12x^2$ is equivalent to

- 1) $x^2(4x + 6)(3x - 2)$
- 2) $2(2x^2 + 3x)(3x^2 - 2x)$
- 3) $2x^2(2x - 3)(3x + 2)$
- 4) $2x^2(2x + 3)(3x - 2)$

34 The fraction $\frac{3}{\sqrt{3a^2b}}$ is equivalent to

- 1) $\frac{1}{a\sqrt{b}}$
- 2) $\frac{\sqrt{b}}{ab}$
- 3) $\frac{\sqrt{3b}}{ab}$
- 4) $\frac{\sqrt{3}}{a}$

35 Given angle A in Quadrant I with $\sin A = \frac{12}{13}$ and angle B in Quadrant II with $\cos B = -\frac{3}{5}$, what is the value of $\cos(A - B)$?

- 1) $\frac{33}{65}$
- 2) $-\frac{33}{65}$
- 3) $\frac{63}{65}$
- 4) $-\frac{63}{65}$

36 Which equation is graphed in the diagram below?

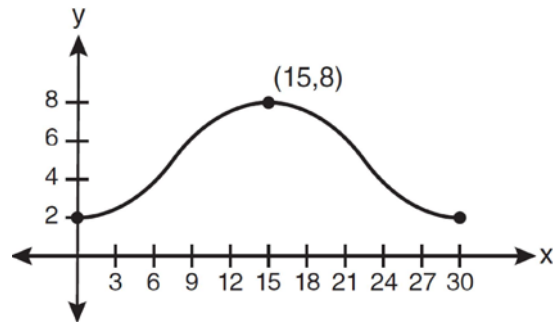

- 1) $y = 3 \cos\left(\frac{\pi}{30}x\right) + 8$
- 2) $y = 3 \cos\left(\frac{\pi}{15}x\right) + 5$
- 3) $y = -3 \cos\left(\frac{\pi}{30}x\right) + 8$
- 4) $y = -3 \cos\left(\frac{\pi}{15}x\right) + 5$

37 In a certain high school, a survey revealed the mean amount of bottled water consumed by students each day was 153 bottles with a standard deviation of 22 bottles. Assuming the survey represented a normal distribution, what is the range of the number of bottled waters that approximately 68.2% of the students drink?

- 1) 131 – 164
- 2) 131 – 175
- 3) 142 – 164
- 4) 142 – 175

38 What are the sum and product of the roots of the equation $6x^2 - 4x - 12 = 0$?

- 1) sum = $-\frac{2}{3}$; product = -2
- 2) sum = $\frac{2}{3}$; product = -2
- 3) sum = -2 ; product = $\frac{2}{3}$
- 4) sum = -2 ; product = $-\frac{2}{3}$

39 In the diagram below, the length of which line segment is equal to the exact value of $\sin \theta$?

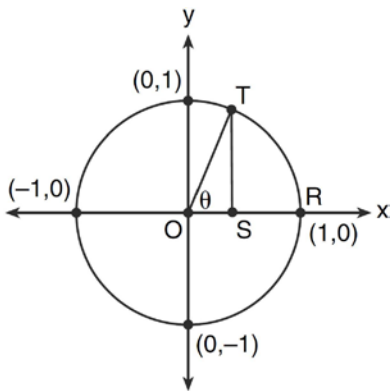

- 1) \overline{TO}
- 2) \overline{TS}
- 3) \overline{OR}
- 4) \overline{OS}

40 Given $\triangle ABC$ with $a = 9$, $b = 10$, and $m\angle B = 70$, what type of triangle can be drawn?

- 1) an acute triangle, only
- 2) an obtuse triangle, only
- 3) both an acute triangle and an obtuse triangle
- 4) neither an acute triangle nor an obtuse triangle

41 Which graph represents one complete cycle of the equation $y = \sin 3\pi x$?

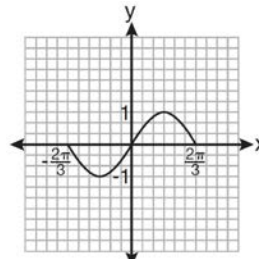

1)

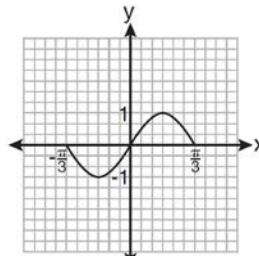

2)

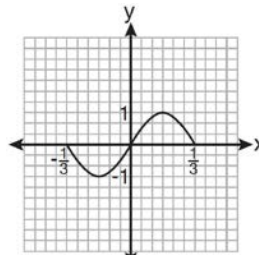

3)

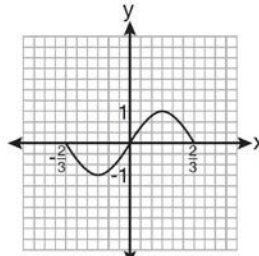

4)

42 In $\triangle ABC$, $m\angle A = 74$, $a = 59.2$, and $c = 60.3$. What are the two possible values for $m\angle C$, to the nearest tenth?

- 1) 73.7 and 106.3
- 2) 73.7 and 163.7
- 3) 78.3 and 101.7
- 4) 78.3 and 168.3

43 The expression $\frac{4}{5 - \sqrt{13}}$ is equivalent to

- 1) $\frac{4\sqrt{13}}{5\sqrt{13} - 13}$
- 2) $\frac{4(5 - \sqrt{13})}{38}$
- 3) $\frac{5 + \sqrt{13}}{3}$
- 4) $\frac{4(5 + \sqrt{13})}{38}$

44 Which expression is equivalent to $\frac{\sqrt{3} + 5}{\sqrt{3} - 5}$?

- 1) $-\frac{14 + 5\sqrt{3}}{11}$
- 2) $-\frac{17 + 5\sqrt{3}}{11}$
- 3) $\frac{14 + 5\sqrt{3}}{14}$
- 4) $\frac{17 + 5\sqrt{3}}{14}$

45 There are eight people in a tennis club. Which expression can be used to find the number of different ways they can place first, second, and third in a tournament?

- 1) ${}_8P_3$
- 2) ${}_8C_3$
- 3) ${}_8P_5$
- 4) ${}_8C_5$

46 On January 1, a share of a certain stock cost \$180. Each month thereafter, the cost of a share of this stock decreased by one-third. If x represents the time, in months, and y represents the cost of the stock, in dollars, which graph best represents the cost of a share over the following 5 months?

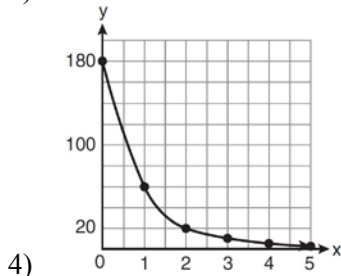
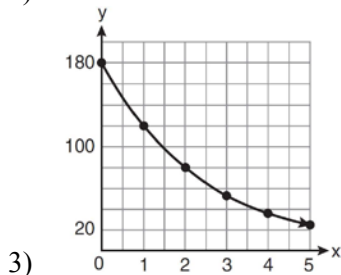
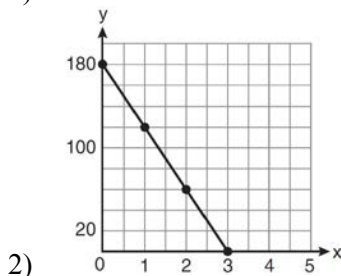
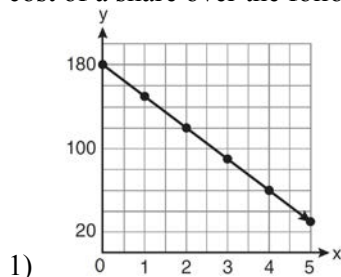

- 47 A dartboard is shown in the diagram below. The two lines intersect at the center of the circle, and the central angle in sector 2 measures $\frac{2\pi}{3}$.

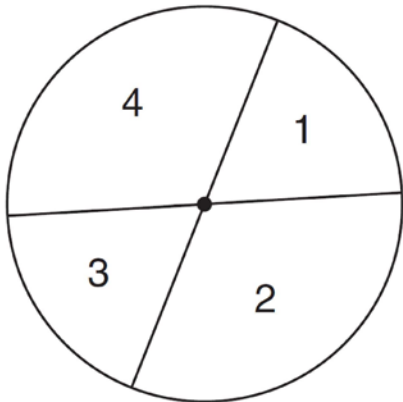

If darts thrown at this board are equally likely to land anywhere on the board, what is the probability that a dart that hits the board will land in either sector 1 or sector 3?

- 1) $\frac{1}{6}$
 - 2) $\frac{1}{3}$
 - 3) $\frac{1}{2}$
 - 4) $\frac{2}{3}$
- 48 When $x^2 + 3x - 4$ is subtracted from $x^3 + 3x^2 - 2x$, the difference is
- 1) $x^3 + 2x^2 - 5x + 4$
 - 2) $x^3 + 2x^2 + x - 4$
 - 3) $-x^3 + 4x^2 + x - 4$
 - 4) $-x^3 - 2x^2 + 5x + 4$

- 49 Which function is one-to-one?

- 1) $f(x) = |x|$
- 2) $f(x) = 2^x$
- 3) $f(x) = x^2$
- 4) $f(x) = \sin x$

- 50 Which equation is represented by the graph below?

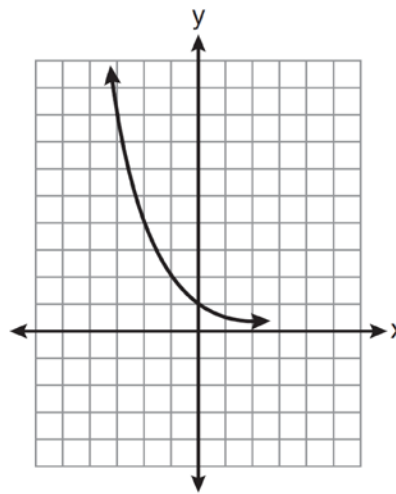

- 1) $y = 5^x$
 - 2) $y = 0.5^x$
 - 3) $y = 5^{-x}$
 - 4) $y = 0.5^{-x}$
- 51 The value of x in the equation $4^{2x+5} = 8^{3x}$ is
- 1) 1
 - 2) 2
 - 3) 5
 - 4) -10

52 Mrs. Hill asked her students to express the sum $1 + 3 + 5 + 7 + 9 + \dots + 39$ using sigma notation. Four different student answers were given. Which student answer is correct?

- 1) $\sum_{k=1}^{20} (2k-1)$
- 2) $\sum_{k=2}^{40} (k-1)$
- 3) $\sum_{k=-1}^{37} (k+2)$
- 4) $\sum_{k=1}^{39} (2k-1)$

53 In $\triangle ABC$, $a = 3$, $b = 5$, and $c = 7$. What is $m\angle C$?

- 1) 22
- 2) 38
- 3) 60
- 4) 120

54 Which summation represents

$5 + 7 + 9 + 11 + \dots + 43$?

- 1) $\sum_{n=5}^{43} n$
- 2) $\sum_{n=1}^{20} (2n+3)$
- 3) $\sum_{n=4}^{24} (2n-3)$
- 4) $\sum_{n=3}^{23} (3n-4)$

55 Which equation is represented by the graph below?

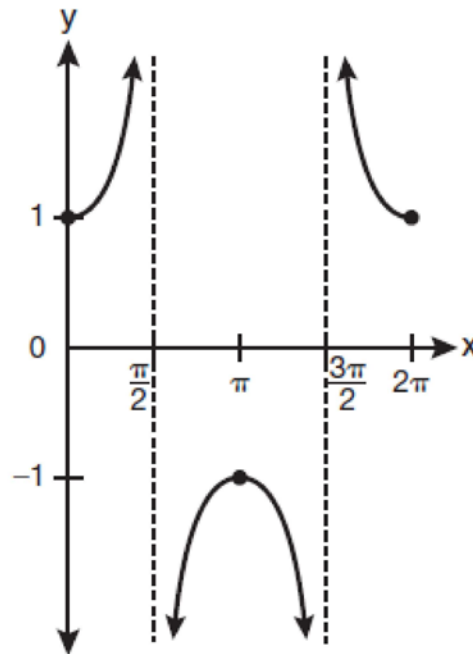

- 1) $y = \cot x$
- 2) $y = \csc x$
- 3) $y = \sec x$
- 4) $y = \tan x$

56 What is the number of degrees in an angle whose radian measure is $\frac{8\pi}{5}$?

- 1) 576
- 2) 288
- 3) 225
- 4) 113

Algebra 2/Trigonometry Multiple Choice Regents Exam Questions

www.jmap.org

57 If n is a negative integer, then which statement is always true?

- 1) $6n^{-2} < 4n^{-1}$
- 2) $\frac{n}{4} > -6n^{-1}$
- 3) $6n^{-1} < 4n^{-1}$
- 4) $4n^{-1} > (6n)^{-1}$

58 The expression $4ab\sqrt{2b} - 3a\sqrt{18b^3} + 7ab\sqrt{6b}$ is equivalent to

- 1) $2ab\sqrt{6b}$
- 2) $16ab\sqrt{2b}$
- 3) $-5ab + 7ab\sqrt{6b}$
- 4) $-5ab\sqrt{2b} + 7ab\sqrt{6b}$

59 A spinner is divided into eight equal sections. Five sections are red and three are green. If the spinner is spun three times, what is the probability that it lands on red *exactly* twice?

- 1) $\frac{25}{64}$
- 2) $\frac{45}{512}$
- 3) $\frac{75}{512}$
- 4) $\frac{225}{512}$

60 What is the period of the function $f(\theta) = -2\cos 3\theta$?

- 1) π
- 2) $\frac{2\pi}{3}$
- 3) $\frac{3\pi}{2}$
- 4) 2π

61 Which ordered pair is a solution of the system of equations shown below? $x + y = 5$

$$(x + 3)^2 + (y - 3)^2 = 53$$

- 1) (2, 3)
- 2) (5, 0)
- 3) (-5, 10)
- 4) (-4, 9)

62 What is the domain of the function shown below?

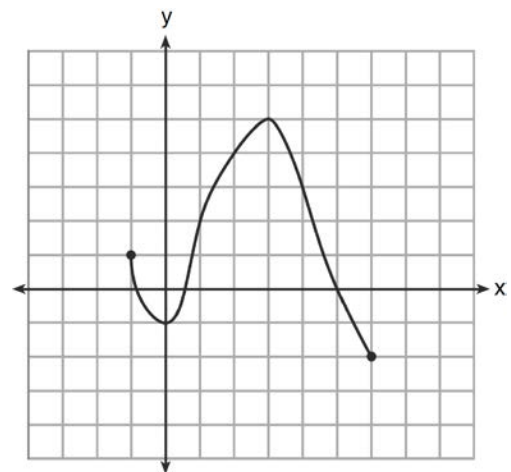

- 1) $-1 \leq x \leq 6$
- 2) $-1 \leq y \leq 6$
- 3) $-2 \leq x \leq 5$
- 4) $-2 \leq y \leq 5$

63 Which statement about the graph of the equation $y = e^x$ is *not* true?

- 1) It is asymptotic to the x -axis.
- 2) The domain is the set of all real numbers.
- 3) It lies in Quadrants I and II.
- 4) It passes through the point $(e, 1)$.

Algebra 2/Trigonometry Multiple Choice Regents Exam Questions

www.jmap.org

- 64 What is the radian measure of an angle whose measure is -420° ?
- 1) $-\frac{7\pi}{3}$
 - 2) $-\frac{7\pi}{6}$
 - 3) $\frac{7\pi}{6}$
 - 4) $\frac{7\pi}{3}$
- 65 What is the fourth term in the binomial expansion $(x - 2)^8$?
- 1) $448x^5$
 - 2) $448x^4$
 - 3) $-448x^5$
 - 4) $-448x^4$
- 66 Which two functions are inverse functions of each other?
- 1) $f(x) = \sin x$ and $g(x) = \cos(x)$
 - 2) $f(x) = 3 + 8x$ and $g(x) = 3 - 8x$
 - 3) $f(x) = e^x$ and $g(x) = \ln x$
 - 4) $f(x) = 2x - 4$ and $g(x) = -\frac{1}{2}x + 4$
- 67 An amateur bowler calculated his bowling average for the season. If the data are normally distributed, about how many of his 50 games were within one standard deviation of the mean?
- 1) 14
 - 2) 17
 - 3) 34
 - 4) 48
- 68 Which task is *not* a component of an observational study?
- 1) The researcher decides who will make up the sample.
 - 2) The researcher analyzes the data received from the sample.
 - 3) The researcher gathers data from the sample, using surveys or taking measurements.
 - 4) The researcher divides the sample into two groups, with one group acting as a control group.
- 69 The roots of the equation $2x^2 + 7x - 3 = 0$ are
- 1) $-\frac{1}{2}$ and -3
 - 2) $\frac{1}{2}$ and 3
 - 3) $\frac{-7 \pm \sqrt{73}}{4}$
 - 4) $\frac{7 \pm \sqrt{73}}{4}$
- 70 In which interval of $f(x) = \cos(x)$ is the inverse also a function?
- 1) $-\frac{\pi}{2} < x < \frac{\pi}{2}$
 - 2) $-\frac{\pi}{2} \leq x \leq \frac{\pi}{2}$
 - 3) $0 \leq x \leq \pi$
 - 4) $\frac{\pi}{2} \leq x \leq \frac{3\pi}{2}$

- 71 What is the coefficient of the fourth term in the expansion of $(a - 4b)^9$?
- 1) $-5,376$
 - 2) -336
 - 3) 336
 - 4) $5,376$
- 72 The sum of $\sqrt[3]{6a^4b^2}$ and $\sqrt[3]{162a^4b^2}$, expressed in simplest radical form, is
- 1) $\sqrt[6]{168a^8b^4}$
 - 2) $2a^2b^3\sqrt[3]{21a^2b}$
 - 3) $4a^3\sqrt[3]{6ab^2}$
 - 4) $10a^2b^3\sqrt[3]{8}$
- 73 What is the period of the function $y = \frac{1}{2} \sin\left(\frac{x}{3} - \pi\right)$?
- 1) $\frac{1}{2}$
 - 2) $\frac{1}{3}$
 - 3) $\frac{2}{3}\pi$
 - 4) 6π
- 74 When $x^{-1} + 1$ is divided by $x + 1$, the quotient equals
- 1) 1
 - 2) $\frac{1}{x}$
 - 3) x
 - 4) $-\frac{1}{x}$
- 75 Which expression is equivalent to $\frac{x^{-1}y^4}{3x^{-5}y^{-1}}$?
- 1) $\frac{x^4y^5}{3}$
 - 2) $\frac{x^5y^4}{3}$
 - 3) $3x^4y^5$
 - 4) $\frac{y^4}{3x^5}$
- 76 What is the product of $\left(\frac{x}{4} - \frac{1}{3}\right)$ and $\left(\frac{x}{4} + \frac{1}{3}\right)$?
- 1) $\frac{x^2}{8} - \frac{1}{9}$
 - 2) $\frac{x^2}{16} - \frac{1}{9}$
 - 3) $\frac{x^2}{8} - \frac{x}{6} - \frac{1}{9}$
 - 4) $\frac{x^2}{16} - \frac{x}{6} - \frac{1}{9}$
- 77 If $r = \sqrt[3]{\frac{A^2B}{C}}$, then $\log r$ can be represented by
- 1) $\frac{1}{6} \log A + \frac{1}{3} \log B - \log C$
 - 2) $3(\log A^2 + \log B - \log C)$
 - 3) $\frac{1}{3} \log(A^2 + B) - C$
 - 4) $\frac{2}{3} \log A + \frac{1}{3} \log B - \frac{1}{3} \log C$

- 78 The table below shows the first-quarter averages for Mr. Harper's statistics class.

Statistics Class Averages

Quarter Averages	Frequency
99	1
97	5
95	4
92	4
90	7
87	2
84	6
81	2
75	1
70	2
65	1

What is the population variance for this set of data?

- 1) 8.2
 2) 8.3
 3) 67.3
 4) 69.3
- 79 The expression $\sin(\theta + 90)^\circ$ is equivalent to
 1) $-\sin \theta$
 2) $-\cos \theta$
 3) $\sin \theta$
 4) $\cos \theta$
- 80 The roots of the equation $x^2 - 10x + 25 = 0$ are
 1) imaginary
 2) real and irrational
 3) real, rational, and equal
 4) real, rational, and unequal
- 81 The value of $\csc 138^\circ 23'$ rounded to four decimal places is
 1) -1.3376
 2) -1.3408
 3) 1.5012
 4) 1.5057
- 82 Which ordered pair is in the solution set of the system of equations shown below?

$$y^2 - x^2 + 32 = 0$$

$$3y - x = 0$$

 1) (2, 6)
 2) (3, 1)
 3) (-1, -3)
 4) (-6, -2)
- 83 Which values of x are in the solution set of the following system of equations?

$$y = 3x - 6$$

$$y = x^2 - x - 6$$

 1) 0, -4
 2) 0, 4
 3) 6, -2
 4) -6, 2
- 84 An auditorium has 21 rows of seats. The first row has 18 seats, and each succeeding row has two more seats than the previous row. How many seats are in the auditorium?
 1) 540
 2) 567
 3) 760
 4) 798

85 Which graph represents the equation $y = \cos^{-1}x$?

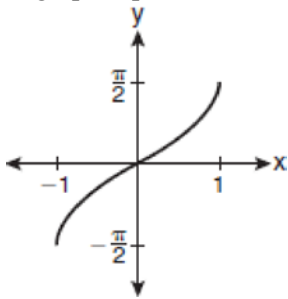

1)

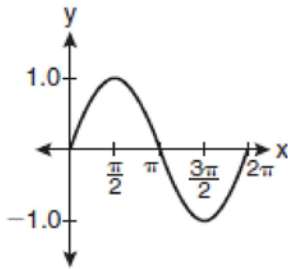

2)

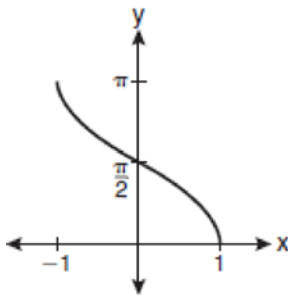

3)

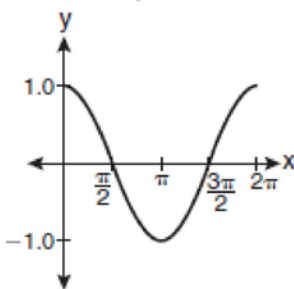

4)

86 What is the number of degrees in an angle whose measure is 2 radians?

- 1) $\frac{360}{\pi}$
- 2) $\frac{\pi}{360}$
- 3) 360
- 4) 90

87 In the diagram below of a unit circle, the ordered pair $\left(-\frac{\sqrt{2}}{2}, -\frac{\sqrt{2}}{2}\right)$ represents the point where the terminal side of θ intersects the unit circle.

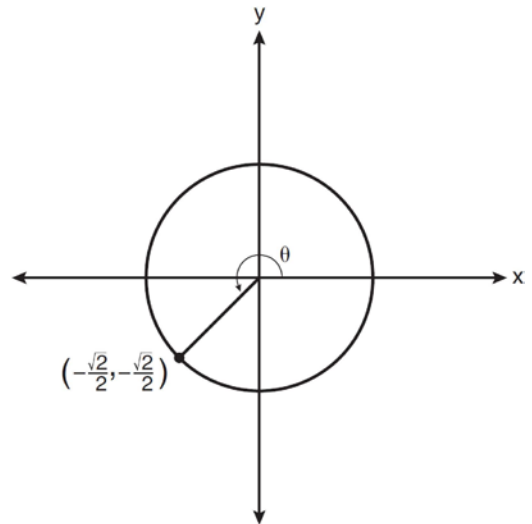

What is $m\angle\theta$?

- 1) 45
- 2) 135
- 3) 225
- 4) 240

88 If $\log_b x = 3 \log_b p - \left(2 \log_b t + \frac{1}{2} \log_b r\right)$, then the value of x is

- 1) $\frac{p^3}{\sqrt{t^2 r}}$
- 2) $p^3 t^2 r^{\frac{1}{2}}$
- 3) $\frac{p^3 t^2}{\sqrt{r}}$
- 4) $\frac{p^3}{t^2 \sqrt{r}}$

Algebra 2/Trigonometry Multiple Choice Regents Exam Questions

www.jmap.org



89 If order does *not* matter, which selection of students would produce the most possible committees?

- 1) 5 out of 15
- 2) 5 out of 25
- 3) 20 out of 25
- 4) 15 out of 25

90 Akeem invests \$25,000 in an account that pays 4.75% annual interest compounded continuously. Using the formula $A = Pe^{rt}$, where A = the amount in the account after t years, P = principal invested, and r = the annual interest rate, how many years, to the *nearest tenth*, will it take for Akeem's investment to triple?

- 1) 10.0
- 2) 14.6
- 3) 23.1
- 4) 24.0

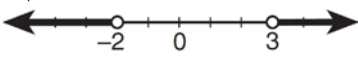
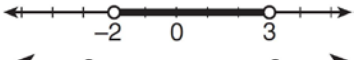
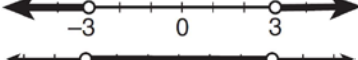
91 What is the graph of the solution set of $|2x - 1| > 5$?

- 1) 
- 2) 
- 3) 
- 4) 

92 Which expression, when rounded to three decimal places, is equal to -1.155 ?

- 1) $\sec\left(\frac{5\pi}{6}\right)$
- 2) $\tan(49^\circ 20')$
- 3) $\sin\left(-\frac{3\pi}{5}\right)$
- 4) $\csc(-118^\circ)$

93 If $m\angle\theta = -50$, which diagram represents θ drawn in standard position?

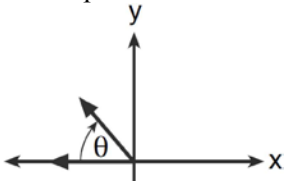
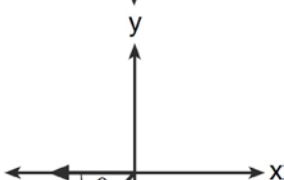
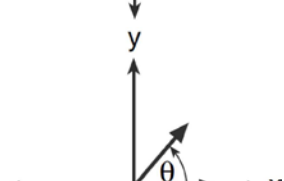
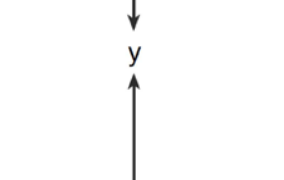
- 1) 
- 2) 
- 3) 
- 4) 

94 What is the value of x in the equation $\log_5 x = 4$?

- 1) 1.16
- 2) 20
- 3) 625
- 4) 1,024

Algebra 2/Trigonometry Multiple Choice Regents Exam Questions

www.jmap.org

- 95 What is the range of $f(x) = (x + 4)^2 + 7$?
- 1) $y \geq -4$
 - 2) $y \geq 4$
 - 3) $y = 7$
 - 4) $y \geq 7$
- 96 A doctor wants to test the effectiveness of a new drug on her patients. She separates her sample of patients into two groups and administers the drug to only one of these groups. She then compares the results. Which type of study *best* describes this situation?
- 1) census
 - 2) survey
 - 3) observation
 - 4) controlled experiment
- 97 What is the product of $\left(\frac{2}{5}x - \frac{3}{4}y^2\right)$ and $\left(\frac{2}{5}x + \frac{3}{4}y^2\right)$?
- 1) $\frac{4}{25}x^2 - \frac{9}{16}y^4$
 - 2) $\frac{4}{25}x - \frac{9}{16}y^2$
 - 3) $\frac{2}{5}x^2 - \frac{3}{4}y^4$
 - 4) $\frac{4}{5}x$
- 98 Expressed as a function of a positive acute angle, $\cos(-305^\circ)$ is equal to
- 1) $-\cos 55^\circ$
 - 2) $\cos 55^\circ$
 - 3) $-\sin 55^\circ$
 - 4) $\sin 55^\circ$
- 99 If $\sin A = \frac{1}{3}$, what is the value of $\cos 2A$?
- 1) $-\frac{2}{3}$
 - 2) $\frac{2}{3}$
 - 3) $-\frac{7}{9}$
 - 4) $\frac{7}{9}$
- 100 The minimum point on the graph of the equation $y = f(x)$ is $(-1, -3)$. What is the minimum point on the graph of the equation $y = f(x) + 5$?
- 1) $(-1, 2)$
 - 2) $(-1, -8)$
 - 3) $(4, -3)$
 - 4) $(-6, -3)$
- 101 The equation $x^2 + y^2 - 2x + 6y + 3 = 0$ is equivalent to
- 1) $(x - 1)^2 + (y + 3)^2 = -3$
 - 2) $(x - 1)^2 + (y + 3)^2 = 7$
 - 3) $(x + 1)^2 + (y + 3)^2 = 7$
 - 4) $(x + 1)^2 + (y + 3)^2 = 10$
- 102 A sequence has the following terms: $a_1 = 4$, $a_2 = 10$, $a_3 = 25$, $a_4 = 62.5$. Which formula represents the n th term in the sequence?
- 1) $a_n = 4 + 2.5n$
 - 2) $a_n = 4 + 2.5(n - 1)$
 - 3) $a_n = 4(2.5)^n$
 - 4) $a_n = 4(2.5)^{n-1}$

Algebra 2/Trigonometry Multiple Choice Regents Exam Questions

www.jmap.org

- 103 In the diagram below of right triangle KTW , $KW = 6$, $KT = 5$, and $m\angle KTW = 90$.

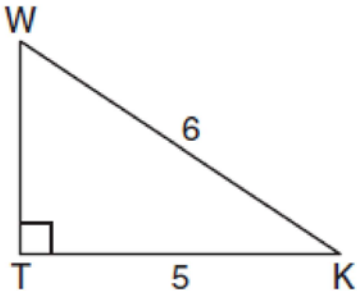

What is the measure of $\angle K$, to the nearest minute?

- 1) $33^\circ 33'$
- 2) $33^\circ 34'$
- 3) $33^\circ 55'$
- 4) $33^\circ 56'$

- 105 In the diagram below of right triangle JTM , $JT = 12$, $JM = 6$, and $m\angle JMT = 90$.

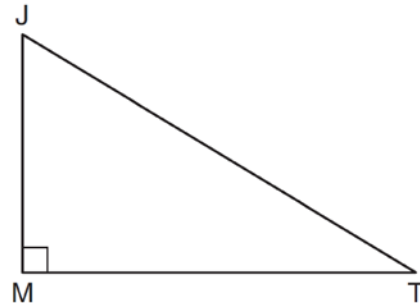

What is the value of $\cot J$?

- 1) $\frac{\sqrt{3}}{3}$
- 2) 2
- 3) $\sqrt{3}$
- 4) $\frac{2\sqrt{3}}{3}$

- 104 Which equation is represented by the graph below?

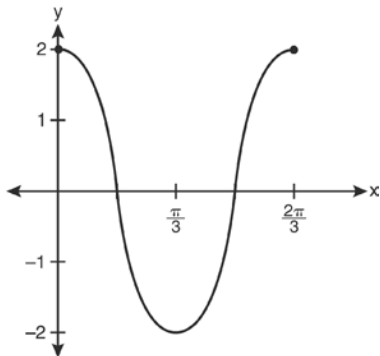

- 1) $y = 2 \cos 3x$
- 2) $y = 2 \sin 3x$
- 3) $y = 2 \cos \frac{2\pi}{3}x$
- 4) $y = 2 \sin \frac{2\pi}{3}x$

- 106 The conjugate of $7 - 5i$ is

- 1) $-7 - 5i$
- 2) $-7 + 5i$
- 3) $7 - 5i$
- 4) $7 + 5i$

- 107 In $\triangle ABC$, $m\angle A = 120$, $b = 10$, and $c = 18$. What is the area of $\triangle ABC$ to the nearest square inch?

- 1) 52
- 2) 78
- 3) 90
- 4) 156

108 For which equation does the sum of the roots equal $\frac{3}{4}$ and the product of the roots equal -2 ?

- 1) $4x^2 - 8x + 3 = 0$
- 2) $4x^2 + 8x + 3 = 0$
- 3) $4x^2 - 3x - 8 = 0$
- 4) $4x^2 + 3x - 2 = 0$

109 How many distinct triangles can be formed if $m\angle A = 35$, $a = 10$, and $b = 13$?

- 1) 1
- 2) 2
- 3) 3
- 4) 0

110 The sides of a parallelogram measure 10 cm and 18 cm. One angle of the parallelogram measures 46 degrees. What is the area of the parallelogram, to the nearest square centimeter?

- 1) 65
- 2) 125
- 3) 129
- 4) 162

111 In $\triangle PQR$, p equals

- 1) $\frac{r \sin P}{\sin Q}$
- 2) $\frac{r \sin P}{\sin R}$
- 3) $\frac{r \sin R}{\sin P}$
- 4) $\frac{q \sin R}{\sin Q}$

112 Samantha constructs the scatter plot below from a set of data.

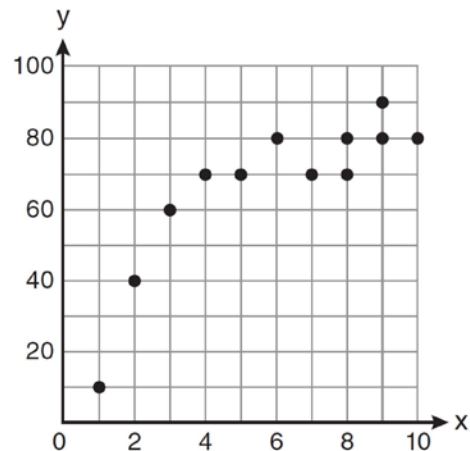

Based on her scatter plot, which regression model would be most appropriate?

- 1) exponential
- 2) linear
- 3) logarithmic
- 4) power

113 If $a = 3$ and $b = -2$, what is the value of the expression $\frac{a^{-2}}{b^{-3}}$?

- 1) $-\frac{9}{8}$
- 2) -1
- 3) $-\frac{8}{9}$
- 4) $\frac{8}{9}$

114 The expression $\log_5\left(\frac{1}{25}\right)$ is equivalent to

- 1) $\frac{1}{2}$
- 2) 2
- 3) $-\frac{1}{2}$
- 4) -2

115 In $\triangle KLM$, $KL = 20$, $LM = 13$, and $m\angle K = 40$. The measure of $\angle M$?

- 1) must be between 0° and 90°
- 2) must equal 90°
- 3) must be between 90° and 180°
- 4) is ambiguous

116 If $\sin^{-1}\left(\frac{5}{8}\right) = A$, then

- 1) $\sin A = \frac{5}{8}$
- 2) $\sin A = \frac{8}{5}$
- 3) $\cos A = \frac{5}{8}$
- 4) $\cos A = \frac{8}{5}$

117 How many negative solutions to the equation

$$2x^3 - 4x^2 + 3x - 1 = 0$$
 exist?

- 1) 1
- 2) 2
- 3) 3
- 4) 0

118 The number of minutes students took to complete a quiz is summarized in the table below.

Minutes	14	15	16	17	18	19	20
Number of Students	5	3	x	5	2	10	1

If the mean number of minutes was 17, which equation could be used to calculate the value of x ?

- 1) $17 = \frac{119 + x}{x}$
- 2) $17 = \frac{119 + 16x}{x}$
- 3) $17 = \frac{446 + x}{26 + x}$
- 4) $17 = \frac{446 + 16x}{26 + x}$

119 A four-digit serial number is to be created from the digits 0 through 9. How many of these serial numbers can be created if 0 can *not* be the first digit, no digit may be repeated, and the last digit must be 5?

- 1) 448
- 2) 504
- 3) 2,240
- 4) 2,520

120 The expression $\sqrt[4]{16x^2y^7}$ is equivalent to

- 1) $2x^{\frac{1}{2}}y^{\frac{7}{4}}$
- 2) $2x^8y^{28}$
- 3) $4x^{\frac{1}{2}}y^{\frac{7}{4}}$
- 4) $4x^8y^{28}$

121 Which graph represents a one-to-one function?

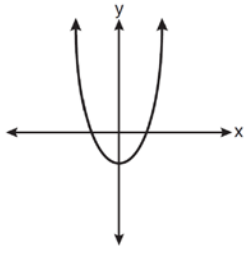
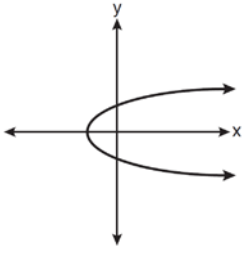
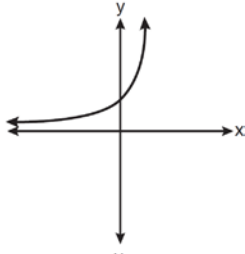
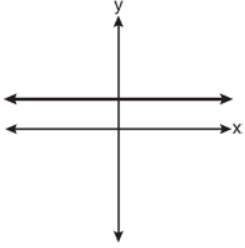
- 1) 
- 2) 
- 3) 
- 4) 

122 Which function is one-to-one?

- 1) $k(x) = x^2 + 2$
- 2) $g(x) = x^3 + 2$
- 3) $f(x) = |x| + 2$
- 4) $j(x) = x^4 + 2$

123 If $f(x) = \sqrt{9 - x^2}$, what are its domain and range?

- 1) domain: $\{x \mid -3 \leq x \leq 3\}$; range: $\{y \mid 0 \leq y \leq 3\}$
- 2) domain: $\{x \mid x \neq \pm 3\}$; range: $\{y \mid 0 \leq y \leq 3\}$
- 3) domain: $\{x \mid x \leq -3 \text{ or } x \geq 3\}$; range: $\{y \mid y \neq 0\}$
- 4) domain: $\{x \mid x \neq 3\}$; range: $\{y \mid y \geq 0\}$

124 The quantities p and q vary inversely. If $p = 20$ when $q = -2$, and $p = x$ when $q = -2x + 2$, then x equals

- 1) -4 and 5
- 2) $\frac{20}{19}$
- 3) -5 and 4
- 4) $-\frac{1}{4}$

125 Twenty different cameras will be assigned to several boxes. Three cameras will be randomly selected and assigned to box A. Which expression can be used to calculate the number of ways that three cameras can be assigned to box A?

- 1) $20!$
- 2) $\frac{20!}{3!}$
- 3) ${}_{20}C_3$
- 4) ${}_{20}P_3$

126 Which value of k satisfies the equation

$$8^{3k+4} = 4^{2k-1}?$$

- 1) -1
- 2) $-\frac{9}{4}$
- 3) -2
- 4) $-\frac{14}{5}$

Algebra 2/Trigonometry Multiple Choice Regents Exam Questions

www.jmap.org

127 What is a formula for the n th term of sequence B shown below?

$$B = 10, 12, 14, 16, \dots$$

- 1) $b_n = 8 + 2n$
- 2) $b_n = 10 + 2n$
- 3) $b_n = 10(2)^n$
- 4) $b_n = 10(2)^{n-1}$

128 If $\tan\left(\arccos\frac{\sqrt{3}}{k}\right) = \frac{\sqrt{3}}{3}$, then k is

- 1) 1
- 2) 2
- 3) $\sqrt{2}$
- 4) $3\sqrt{2}$

129 Brian correctly used a method of completing the square to solve the equation $x^2 + 7x - 11 = 0$. Brian's first step was to rewrite the equation as $x^2 + 7x = 11$. He then added a number to both sides of the equation. Which number did he add?

- 1) $\frac{7}{2}$
- 2) $\frac{49}{4}$
- 3) $\frac{49}{2}$
- 4) 49

130 The roots of the equation $9x^2 + 3x - 4 = 0$ are

- 1) imaginary
- 2) real, rational, and equal
- 3) real, rational, and unequal
- 4) real, irrational, and unequal

131 If the amount of time students work in any given week is normally distributed with a mean of 10 hours per week and a standard deviation of 2 hours, what is the probability a student works between 8 and 11 hours per week?

- 1) 34.1%
- 2) 38.2%
- 3) 53.2%
- 4) 68.2%

132 Which graph does *not* represent a function?

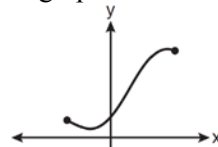

1)

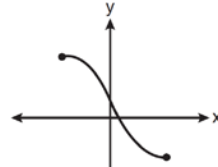

2)

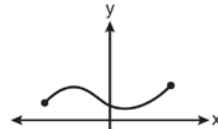

3)

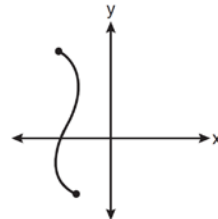

4)

Algebra 2/Trigonometry Multiple Choice Regents Exam Questions

www.jmap.org

- 133 Susie invests \$500 in an account that is compounded continuously at an annual interest rate of 5%, according to the formula $A = Pe^{rt}$, where A is the amount accrued, P is the principal, r is the rate of interest, and t is the time, in years. Approximately how many years will it take for Susie's money to double?
- 1) 1.4
 - 2) 6.0
 - 3) 13.9
 - 4) 14.7
- 134 In the interval $0^\circ \leq x < 360^\circ$, $\tan x$ is undefined when x equals
- 1) 0° and 90°
 - 2) 90° and 180°
 - 3) 180° and 270°
 - 4) 90° and 270°
- 135 If $f(x) = \frac{1}{2}x - 3$ and $g(x) = 2x + 5$, what is the value of $(g \circ f)(4)$?
- 1) -13
 - 2) 3.5
 - 3) 3
 - 4) 6
- 136 If $\log x^2 - \log 2a = \log 3a$, then $\log x$ expressed in terms of $\log a$ is equivalent to
- 1) $\frac{1}{2} \log 5a$
 - 2) $\frac{1}{2} \log 6 + \log a$
 - 3) $\log 6 + \log a$
 - 4) $\log 6 + 2 \log a$
- 137 If $x^2 + 2 = 6x$ is solved by completing the square, an intermediate step would be
- 1) $(x + 3)^2 = 7$
 - 2) $(x - 3)^2 = 7$
 - 3) $(x - 3)^2 = 11$
 - 4) $(x - 6)^2 = 34$
- 138 If $\log 2 = a$ and $\log 3 = b$, the expression $\log \frac{9}{20}$ is equivalent to
- 1) $2b - a + 1$
 - 2) $2b - a - 1$
 - 3) $b^2 - a + 10$
 - 4) $\frac{2b}{a + 1}$
- 139 The equation $y - 2 \sin \theta = 3$ may be rewritten as
- 1) $f(y) = 2 \sin x + 3$
 - 2) $f(y) = 2 \sin \theta + 3$
 - 3) $f(x) = 2 \sin \theta + 3$
 - 4) $f(\theta) = 2 \sin \theta + 3$
- 140 The value of the expression $2 \sum_{n=0}^2 (n^2 + 2^n)$ is
- 1) 12
 - 2) 22
 - 3) 24
 - 4) 26

141 Which equation is sketched in the diagram below?

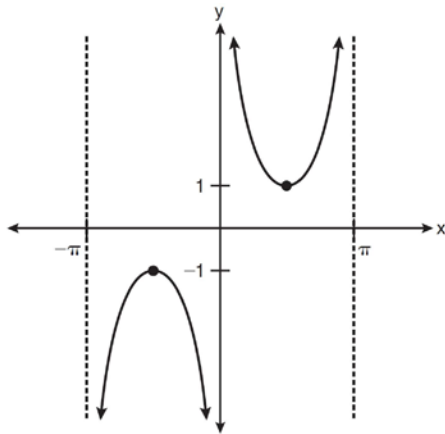

- 1) $y = \csc x$
- 2) $y = \sec x$
- 3) $y = \cot x$
- 4) $y = \tan x$

142 What is the solution set of the equation

$$-\sqrt{2} \sec x = 2 \text{ when } 0^\circ \leq x < 360^\circ?$$

- 1) $\{45^\circ, 135^\circ, 225^\circ, 315^\circ\}$
- 2) $\{45^\circ, 315^\circ\}$
- 3) $\{135^\circ, 225^\circ\}$
- 4) $\{225^\circ, 315^\circ\}$

143 The expression $(x^2 - 1)^{-\frac{2}{3}}$ is equivalent to

- 1) $\sqrt[3]{(x^2 - 1)^2}$
- 2) $\frac{1}{\sqrt[3]{(x^2 - 1)^2}}$
- 3) $\sqrt{(x^2 - 1)^3}$
- 4) $\frac{1}{\sqrt{(x^2 - 1)^3}}$

144 The expression $\frac{2x+4}{\sqrt{x+2}}$ is equivalent to

- 1) $\frac{(2x+4)\sqrt{x-2}}{x-2}$
- 2) $\frac{(2x+4)\sqrt{x-2}}{x-4}$
- 3) $2\sqrt{x-2}$
- 4) $2\sqrt{x+2}$

145 When simplified, the expression $\left(\frac{w^{-5}}{w^{-9}}\right)^{\frac{1}{2}}$ is

equivalent to

- 1) w^{-7}
- 2) w^2
- 3) w^7
- 4) w^{14}

146 If $\sin A = \frac{2}{3}$ where $0^\circ < A < 90^\circ$, what is the value of $\sin 2A$?

- 1) $\frac{2\sqrt{5}}{3}$
- 2) $\frac{2\sqrt{5}}{9}$
- 3) $\frac{4\sqrt{5}}{9}$
- 4) $-\frac{4\sqrt{5}}{9}$

Algebra 2/Trigonometry Multiple Choice Regents Exam Questions

www.jmap.org

147 The value of $\tan 126^\circ 43'$ to the nearest ten-thousandth is

- 1) -1.3407
- 2) -1.3408
- 3) -1.3548
- 4) -1.3549

148 Which graph does *not* represent a function?

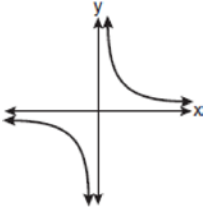
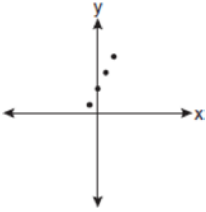
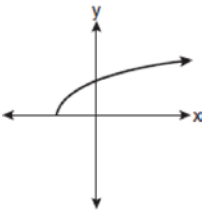
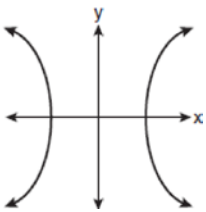
- 1) 
- 2) 
- 3) 
- 4) 

149 What is the number of degrees in an angle whose radian measure is $\frac{11\pi}{12}$?

- 1) 150
- 2) 165
- 3) 330
- 4) 518

150 Which problem involves evaluating ${}_6P_4$?

- 1) How many different four-digit ID numbers can be formed using 1, 2, 3, 4, 5, and 6 without repetition?
- 2) How many different subcommittees of four can be chosen from a committee having six members?
- 3) How many different outfits can be made using six shirts and four pairs of pants?
- 4) How many different ways can one boy and one girl be selected from a group of four boys and six girls?

151 Which value of r represents data with a strong negative linear correlation between two variables?

- 1) -1.07
- 2) -0.89
- 3) -0.14
- 4) 0.92

152 The area of triangle ABC is 42. If $AB = 8$ and $m\angle B = 61$, the length of BC is approximately

- 1) 5.1
- 2) 9.2
- 3) 12.0
- 4) 21.7

153 Given the relation $\{(8, 2), (3, 6), (7, 5), (k, 4)\}$, which value of k will result in the relation *not* being a function?

- 1) 1
- 2) 2
- 3) 3
- 4) 4

154 The graph of $y = f(x)$ is shown below.

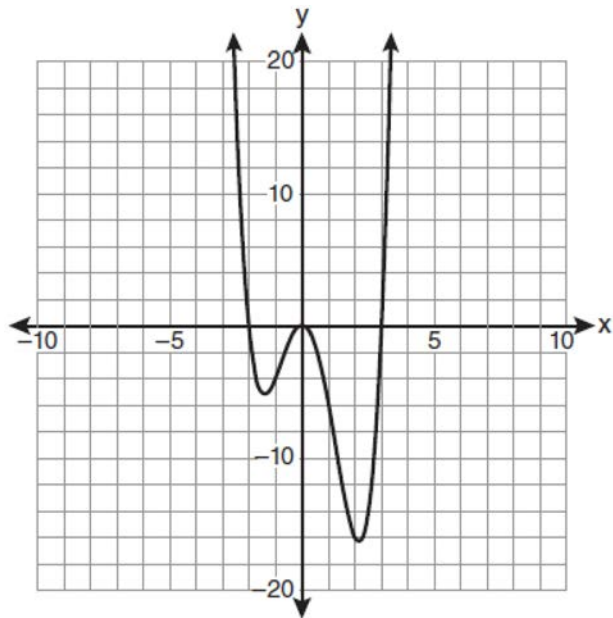

Which set lists all the real solutions of $f(x) = 0$?

- 1) $\{-3, 2\}$
- 2) $\{-2, 3\}$
- 3) $\{-3, 0, 2\}$
- 4) $\{-2, 0, 3\}$

155 Which values of x are solutions of the equation

$$x^3 + x^2 - 2x = 0?$$

- 1) $0, 1, 2$
- 2) $0, 1, -2$
- 3) $0, -1, 2$
- 4) $0, -1, -2$

156 What is the fourth term in the expansion of $(3x - 2)^5$?

- 1) $-720x^2$
- 2) $-240x$
- 3) $720x^2$
- 4) $1,080x^3$

157 The solution set of the inequality $x^2 - 3x > 10$ is

- 1) $\{x | -2 < x < 5\}$
- 2) $\{x | 0 < x < 3\}$
- 3) $\{x | x < -2 \text{ or } x > 5\}$
- 4) $\{x | x < -5 \text{ or } x > 2\}$

158 What is the range of the function shown below?

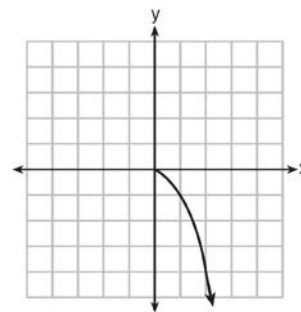

- 1) $x \leq 0$
- 2) $x \geq 0$
- 3) $y \leq 0$
- 4) $y \geq 0$

159 The expression $\cos^2 \theta - \cos 2\theta$ is equivalent to

- 1) $\sin^2 \theta$
- 2) $-\sin^2 \theta$
- 3) $\cos^2 \theta + 1$
- 4) $-\cos^2 \theta - 1$

160 Which ratio represents $\csc A$ in the diagram below?

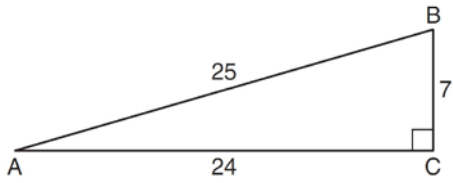

- 1) $\frac{25}{24}$
- 2) $\frac{25}{7}$
- 3) $\frac{24}{7}$
- 4) $\frac{7}{24}$

161 If p varies inversely as q , and $p = 10$ when $q = \frac{3}{2}$,

what is the value of p when $q = \frac{3}{5}$?

- 1) 25
- 2) 15
- 3) 9
- 4) 4

162 What is the conjugate of $\frac{1}{2} + \frac{3}{2}i$?

- 1) $-\frac{1}{2} + \frac{3}{2}i$
- 2) $\frac{1}{2} - \frac{3}{2}i$
- 3) $\frac{3}{2} + \frac{1}{2}i$
- 4) $-\frac{1}{2} - \frac{3}{2}i$

163 Which graph represents the function $\log_2 x = y$?

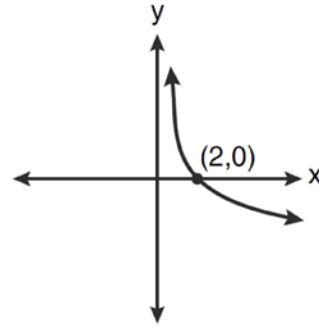
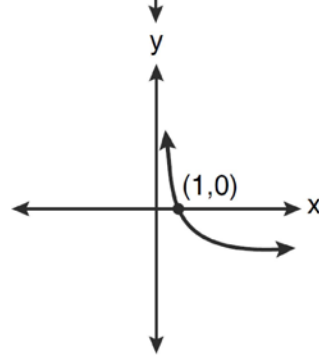
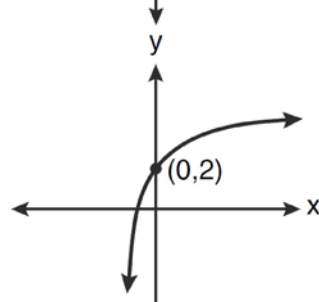
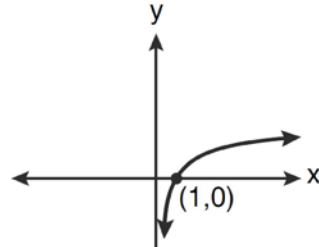

Algebra 2/Trigonometry Multiple Choice Regents Exam Questions

www.jmap.org

164 What are the values of θ in the interval $0^\circ \leq \theta < 360^\circ$ that satisfy the equation

$$\tan \theta - \sqrt{3} = 0?$$

- 1) $60^\circ, 240^\circ$
- 2) $72^\circ, 252^\circ$
- 3) $72^\circ, 108^\circ, 252^\circ, 288^\circ$
- 4) $60^\circ, 120^\circ, 240^\circ, 300^\circ$

165 The solution set of $4^{x^2+4x} = 2^{-6}$ is

- 1) $\{1, 3\}$
- 2) $\{-1, 3\}$
- 3) $\{-1, -3\}$
- 4) $\{1, -3\}$

166 The expression $\sqrt[3]{64a^{16}}$ is equivalent to

- 1) $8a^4$
- 2) $8a^8$
- 3) $4a^5\sqrt[3]{a}$
- 4) $4a^3\sqrt{a^5}$

167 The expression $4 + \sum_{k=2}^5 3(k-x)$ is equal to

- 1) $58 - 4x$
- 2) $46 - 4x$
- 3) $58 - 12x$
- 4) $46 - 12x$

168 In parallelogram $BFLO$, $OL = 3.8$, $LF = 7.4$, and $m\angle O = 126$. If diagonal BL is drawn, what is the area of $\triangle BLF$?

- 1) 11.4
- 2) 14.1
- 3) 22.7
- 4) 28.1

169 What is the principal value of $\cos^{-1}\left(-\frac{\sqrt{3}}{2}\right)$?

- 1) -30°
- 2) 60°
- 3) 150°
- 4) 240°

170 Which equation is represented by the graph below?

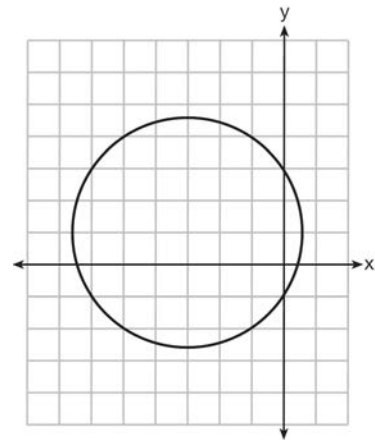

- 1) $(x-3)^2 + (y+1)^2 = 5$
- 2) $(x+3)^2 + (y-1)^2 = 5$
- 3) $(x-1)^2 + (y+3)^2 = 13$
- 4) $(x+3)^2 + (y-1)^2 = 13$

Algebra 2/Trigonometry Multiple Choice Regents Exam Questions

www.jmap.org

171 Written in simplest form, the expression $\frac{\frac{x}{4} - \frac{1}{x}}{\frac{1}{2x} + \frac{1}{4}}$

is equivalent to

- 1) $x - 1$
- 2) $x - 2$
- 3) $\frac{x-2}{2}$
- 4) $\frac{x^2-4}{x+2}$

172 Factored completely, the expression $6x - x^3 - x^2$ is equivalent to

- 1) $x(x+3)(x-2)$
- 2) $x(x-3)(x+2)$
- 3) $-x(x-3)(x+2)$
- 4) $-x(x+3)(x-2)$

173 The product of i^7 and i^5 is equivalent to

- 1) 1
- 2) -1
- 3) i
- 4) $-i$

174 In the right triangle shown below, what is the measure of angle S , to the nearest minute?

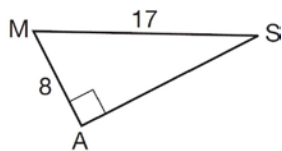

- 1) $28^\circ 1'$
- 2) $28^\circ 4'$
- 3) $61^\circ 56'$
- 4) $61^\circ 93'$

175 What is the domain of the function

$$f(x) = \sqrt{x-2} + 3?$$

- 1) $(-\infty, \infty)$
- 2) $(2, \infty)$
- 3) $[2, \infty)$
- 4) $[3, \infty)$

176 What is the conjugate of $-2 + 3i$?

- 1) $-3 + 2i$
- 2) $-2 - 3i$
- 3) $2 - 3i$
- 4) $3 + 2i$

177 Which expression is equivalent to $\frac{2x^{-2}y^{-2}}{4y^{-5}}$?

- 1) $\frac{y^3}{2x^2}$
- 2) $\frac{2y^3}{x^2}$
- 3) $\frac{2x^2}{y^3}$
- 4) $\frac{x^2}{2y^3}$

178 Four points on the graph of the function $f(x)$ are shown below.

$$\{(0, 1), (1, 2), (2, 4), (3, 8)\}$$

Which equation represents $f(x)$?

- 1) $f(x) = 2^x$
- 2) $f(x) = 2x$
- 3) $f(x) = x + 1$
- 4) $f(x) = \log_2 x$

179 The graph of $y = x^3 - 4x^2 + x + 6$ is shown below.

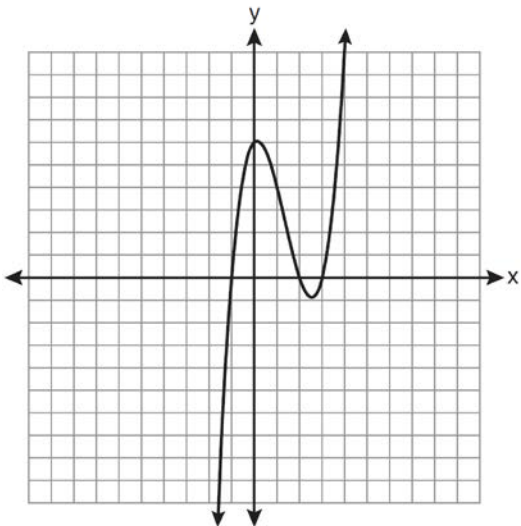

What is the product of the roots of the equation

$$x^3 - 4x^2 + x + 6 = 0?$$

- 1) -36
- 2) -6
- 3) 6
- 4) 4

180 The solution set of the equation $\sqrt{x+3} = 3-x$ is

- 1) $\{1\}$
- 2) $\{0\}$
- 3) $\{1, 6\}$
- 4) $\{2, 3\}$

181 Which value of r represents data with a strong positive linear correlation between two variables?

- 1) 0.89
- 2) 0.34
- 3) 1.04
- 4) 0.01

182 An angle, P , drawn in standard position, terminates in Quadrant II if

- 1) $\cos P < 0$ and $\csc P < 0$
- 2) $\sin P > 0$ and $\cos P > 0$
- 3) $\csc P > 0$ and $\cot P < 0$
- 4) $\tan P < 0$ and $\sec P > 0$

183 What is the equation of the graph shown below?

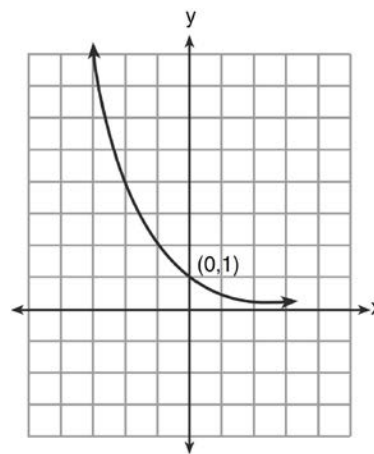

- 1) $y = 2^x$
- 2) $y = 2^{-x}$
- 3) $x = 2^y$
- 4) $x = 2^{-y}$

184 What is the range of $f(x) = |x - 3| + 2$?

- 1) $\{x|x \geq 3\}$
- 2) $\{y|y \geq 2\}$
- 3) $\{x|x \in \text{real numbers}\}$
- 4) $\{y|y \in \text{real numbers}\}$

185 Which graph shows $y = \cos^{-1}x$?

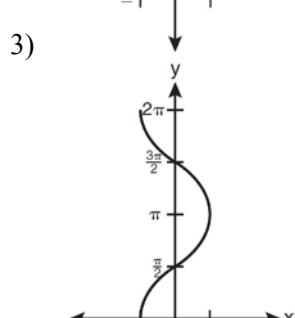
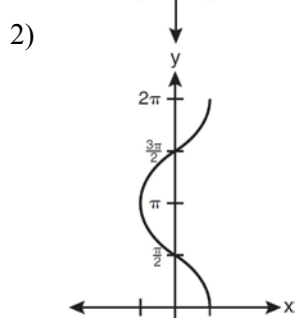
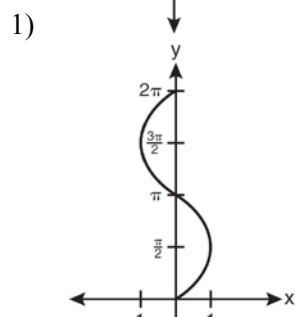
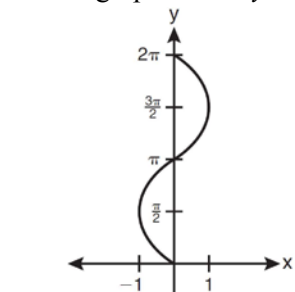

186 Which equation represents the circle shown in the graph below that passes through the point $(0, -1)$?

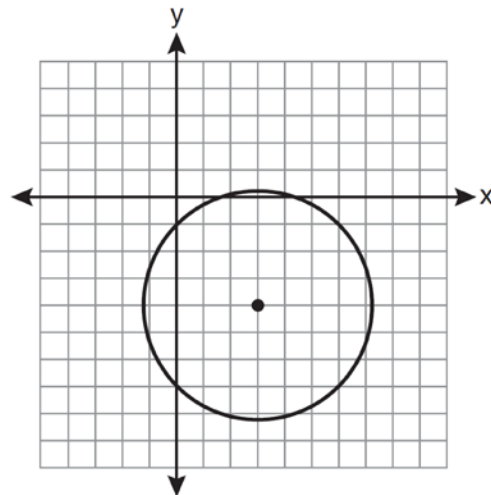

- 1) $(x - 3)^2 + (y + 4)^2 = 16$
- 2) $(x - 3)^2 + (y + 4)^2 = 18$
- 3) $(x + 3)^2 + (y - 4)^2 = 16$
- 4) $(x + 3)^2 + (y - 4)^2 = 18$

187 The function $f(x) = \tan x$ is defined in such a way that $f^{-1}(x)$ is a function. What can be the domain of $f(x)$?

- 1) $\{x \mid 0 \leq x \leq \pi\}$
- 2) $\{x \mid 0 \leq x \leq 2\pi\}$
- 3) $\left\{x \mid -\frac{\pi}{2} < x < \frac{\pi}{2}\right\}$
- 4) $\left\{x \mid -\frac{\pi}{2} < x < \frac{3\pi}{2}\right\}$

188 The expression $x^{-\frac{2}{5}}$ is equivalent to

- 1) $-\sqrt[2]{x^5}$
- 2) $-\sqrt[5]{x^2}$
- 3) $\frac{1}{\sqrt[2]{x^5}}$
- 4) $\frac{1}{\sqrt[5]{x^2}}$

189 What are the domain and the range of the function shown in the graph below?

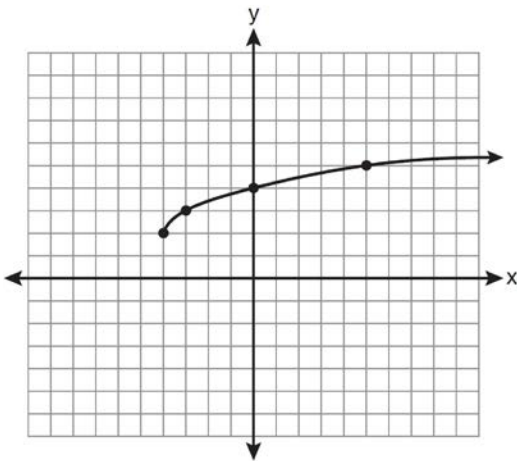

- 1) $\{x|x > -4\}; \{y|y > 2\}$
- 2) $\{x|x \geq -4\}; \{y|y \geq 2\}$
- 3) $\{x|x > 2\}; \{y|y > -4\}$
- 4) $\{x|x \geq 2\}; \{y|y \geq -4\}$

190 In simplest form, $\sqrt{-300}$ is equivalent to

- 1) $3i\sqrt{10}$
- 2) $5i\sqrt{12}$
- 3) $10i\sqrt{3}$
- 4) $12i\sqrt{5}$

191 If $f(x) = 4x - x^2$ and $g(x) = \frac{1}{x}$, then $(f \circ g)\left(\frac{1}{2}\right)$ is

equal to

- 1) $\frac{4}{7}$
- 2) -2
- 3) $\frac{7}{2}$
- 4) 4

192 Which expression is equivalent to $(n \circ m \circ p)(x)$, given $m(x) = \sin x$, $n(x) = 3x$, and $p(x) = x^2$?

- 1) $\sin(3x)^2$
- 2) $3 \sin x^2$
- 3) $\sin^2(3x)$
- 4) $3 \sin^2 x$

193 The points $(2, 3)$, $\left(4, \frac{3}{4}\right)$, and $(6, d)$ lie on the graph of a function. If y is inversely proportional to the square of x , what is the value of d ?

- 1) 1
- 2) $\frac{1}{3}$
- 3) 3
- 4) 27

194 How many different six-letter arrangements can be made using the letters of the word "TATTOO"?

- 1) 60
- 2) 90
- 3) 120
- 4) 720

Algebra 2/Trigonometry Multiple Choice Regents Exam Questions

www.jmap.org

195 The solutions of the equation $y^2 - 3y = 9$ are

- 1) $\frac{3 \pm 3i\sqrt{3}}{2}$
- 2) $\frac{3 \pm 3i\sqrt{5}}{2}$
- 3) $\frac{-3 \pm 3\sqrt{5}}{2}$
- 4) $\frac{3 \pm 3\sqrt{5}}{2}$

196 What is the formula for the n th term of the sequence 54, 18, 6, ...?

- 1) $a_n = 6\left(\frac{1}{3}\right)^n$
- 2) $a_n = 6\left(\frac{1}{3}\right)^{n-1}$
- 3) $a_n = 54\left(\frac{1}{3}\right)^n$
- 4) $a_n = 54\left(\frac{1}{3}\right)^{n-1}$

197 What is the common ratio of the sequence

$$\frac{1}{64}a^5b^3, -\frac{3}{32}a^3b^4, \frac{9}{16}ab^5, \dots?$$

- 1) $-\frac{3b}{2a^2}$
- 2) $-\frac{6b}{a^2}$
- 3) $-\frac{3a^2}{b}$
- 4) $-\frac{6a^2}{b}$

198 If $\angle A$ is acute and $\tan A = \frac{2}{3}$, then

- 1) $\cot A = \frac{2}{3}$
- 2) $\cot A = \frac{1}{3}$
- 3) $\cot(90^\circ - A) = \frac{2}{3}$
- 4) $\cot(90^\circ - A) = \frac{1}{3}$

199 The conjugate of the complex expression $-5x + 4i$ is

- 1) $5x - 4i$
- 2) $5x + 4i$
- 3) $-5x - 4i$
- 4) $-5x + 4i$

200 What is a positive value of $\tan \frac{1}{2}x$, when

$$\sin x = 0.8?$$

- 1) 0.5
- 2) 0.4
- 3) 0.33
- 4) 0.25

201 What is the solution set of the equation

$$|4a + 6| - 4a = -10?$$

- 1) \emptyset
- 2) $\{0\}$
- 3) $\left\{\frac{1}{2}\right\}$
- 4) $\left\{0, \frac{1}{2}\right\}$

202 Which calculator output shows the strongest linear relationship between x and y ?

Lin Reg

$$y = a + bx$$

$$a = 59.026$$

$$b = 6.767$$

1) $r = .8643$

Lin Reg

$$y = a + bx$$

$$a = .7$$

$$b = 24.2$$

2) $r = .8361$

Lin Reg

$$y = a + bx$$

$$a = 2.45$$

$$b = .95$$

3) $r = .6022$

Lin Reg

$$y = a + bx$$

$$a = -2.9$$

$$b = 24.1$$

4) $r = -.8924$

203 If $f(x) = \frac{x}{x^2 - 16}$, what is the value of $f(-10)$?

1) $-\frac{5}{2}$

2) $-\frac{5}{42}$

3) $\frac{5}{58}$

4) $\frac{5}{18}$

204 The expression $(x + i)^2 - (x - i)^2$ is equivalent to

1) 0

2) -2

3) $-2 + 4xi$

4) $4xi$

205 Which graph represents a relation that is *not* a function?

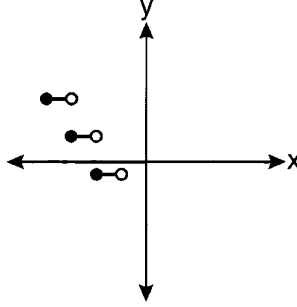
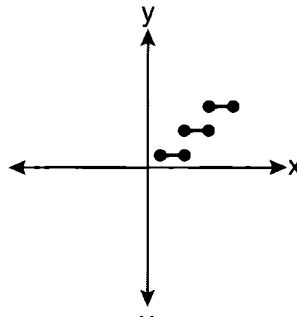
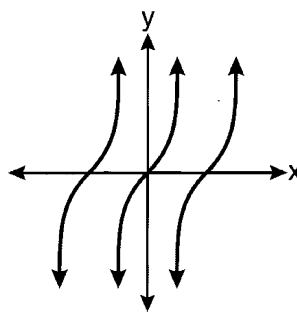
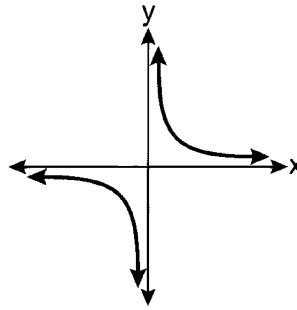

Algebra 2/Trigonometry Multiple Choice Regents Exam Questions

www.jmap.org

206 The expression $\frac{\sin^2 \theta + \cos^2 \theta}{1 - \sin^2 \theta}$ is equivalent to

- 1) $\cos^2 \theta$
- 2) $\sin^2 \theta$
- 3) $\sec^2 \theta$
- 4) $\csc^2 \theta$

207 The value of the expression $\sum_{r=3}^5 (-r^2 + r)$ is

- 1) -38
- 2) -12
- 3) 26
- 4) 62

208 A circle is drawn to represent a pizza with a 12 inch diameter. The circle is cut into eight congruent pieces. What is the length of the outer edge of any one piece of this circle?

- 1) $\frac{3\pi}{4}$
- 2) π
- 3) $\frac{3\pi}{2}$
- 4) 3π

209 If $x = 3i$, $y = 2i$, and $z = m + i$, the expression xy^2z equals

- 1) $-12 - 12mi$
- 2) $-6 - 6mi$
- 3) $12 - 12mi$
- 4) $6 - 6mi$

210 The expression $2 \log x - (3 \log y + \log z)$ is equivalent to

- 1) $\log \frac{x^2}{y^3 z}$
- 2) $\log \frac{x^2 z}{y^3}$
- 3) $\log \frac{2x}{3yz}$
- 4) $\log \frac{2xz}{3y}$

211 Which graph represents the solution set of

$$\left| \frac{4x - 5}{3} \right| > 1?$$

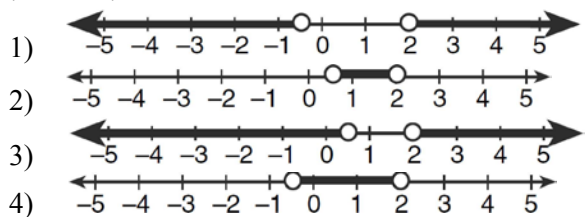

212 Which expression is equivalent to $(9x^2y^6)^{-\frac{1}{2}}$?

- 1) $\frac{1}{3xy^3}$
- 2) $3xy^3$
- 3) $\frac{3}{xy^3}$
- 4) $\frac{xy^3}{3}$

Algebra 2/Trigonometry Multiple Choice Regents Exam Questions

www.jmap.org

213 When $\frac{3}{2}x^2 - \frac{1}{4}x - 4$ is subtracted from

$\frac{5}{2}x^2 - \frac{3}{4}x + 1$, the difference is

- 1) $-x^2 + \frac{1}{2}x - 5$
- 2) $x^2 - \frac{1}{2}x + 5$
- 3) $-x^2 - x - 3$
- 4) $x^2 - x - 3$

214 If $f(x) = x^2 - 5$ and $g(x) = 6x$, then $g(f(x))$ is equal to

- 1) $6x^3 - 30x$
- 2) $6x^2 - 30$
- 3) $36x^2 - 5$
- 4) $x^2 + 6x - 5$

215 The product of $(3 + \sqrt{5})$ and $(3 - \sqrt{5})$ is

- 1) $4 - 6\sqrt{5}$
- 2) $14 - 6\sqrt{5}$
- 3) 14
- 4) 4

216 The lengths of 100 pipes have a normal distribution with a mean of 102.4 inches and a standard deviation of 0.2 inch. If one of the pipes measures exactly 102.1 inches, its length lies

- 1) below the 16th percentile
- 2) between the 50th and 84th percentiles
- 3) between the 16th and 50th percentiles
- 4) above the 84th percentile

217 Which graph best represents the inequality $y + 6 \geq x^2 - x$?

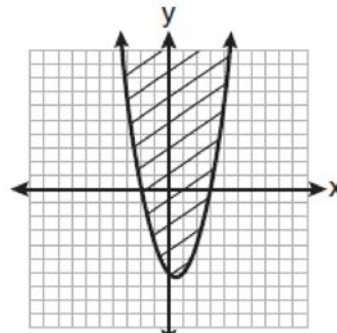

1)

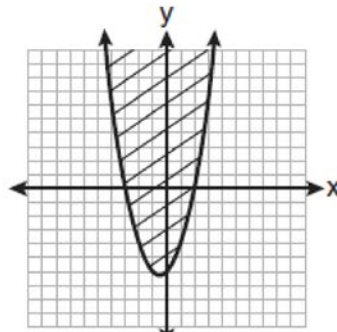

2)

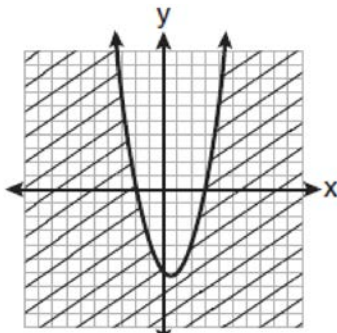

3)

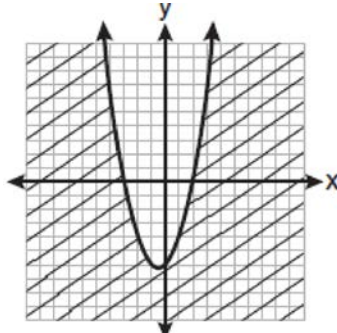

4)

Algebra 2/Trigonometry Multiple Choice Regents Exam Questions

www.jmap.org

218 What is the solution set for $2 \cos \theta - 1 = 0$ in the interval $0^\circ \leq \theta < 360^\circ$?

- 1) $\{30^\circ, 150^\circ\}$
- 2) $\{60^\circ, 120^\circ\}$
- 3) $\{30^\circ, 330^\circ\}$
- 4) $\{60^\circ, 300^\circ\}$

219 The expression $\log_8 64$ is equivalent to

- 1) 8
- 2) 2
- 3) $\frac{1}{2}$
- 4) $\frac{1}{8}$

220 In $\triangle MNP$, $m = 6$ and $n = 10$. Two distinct triangles can be constructed if the measure of angle M is

- 1) 35
- 2) 40
- 3) 45
- 4) 50

221 Which relation is *not* a function?

- 1) $(x - 2)^2 + y^2 = 4$
- 2) $x^2 + 4x + y = 4$
- 3) $x + y = 4$
- 4) $xy = 4$

222 A circle has a radius of 4 inches. In inches, what is the length of the arc intercepted by a central angle of 2 radians?

- 1) 2π
- 2) 2
- 3) 8π
- 4) 8

223 Which equation has roots with the sum equal to $\frac{9}{4}$ and the product equal to $\frac{3}{4}$?

- 1) $4x^2 + 9x + 3 = 0$
- 2) $4x^2 + 9x - 3 = 0$
- 3) $4x^2 - 9x + 3 = 0$
- 4) $4x^2 - 9x - 3 = 0$

224 A study finds that 80% of the local high school students text while doing homework. Ten students are selected at random from the local high school. Which expression would be part of the process used to determine the probability that, *at most*, 7 of the 10 students text while doing homework?

- 1) ${}_{10}C_6 \left(\frac{4}{5}\right)^6 \left(\frac{1}{5}\right)^4$
- 2) ${}_{10}C_7 \left(\frac{4}{5}\right)^{10} \left(\frac{1}{5}\right)^7$
- 3) ${}_{10}C_8 \left(\frac{7}{10}\right)^{10} \left(\frac{3}{10}\right)^2$
- 4) ${}_{10}C_9 \left(\frac{7}{10}\right)^9 \left(\frac{3}{10}\right)^1$

225 The simplest form of $\frac{1 - \frac{4}{x}}{1 - \frac{2}{x} - \frac{8}{x^2}}$ is

- 1) $\frac{1}{2}$
- 2) $\frac{x}{x+2}$
- 3) $\frac{x}{3}$
- 4) $-\frac{x}{x-2}$

Algebra 2/Trigonometry Multiple Choice Regents Exam Questions

www.jmap.org

226 In which graph is θ coterminal with an angle of -70° ?

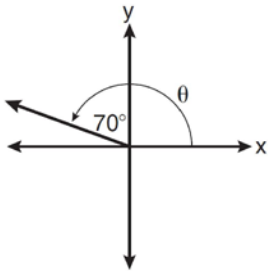

1)

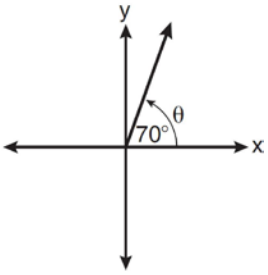

2)

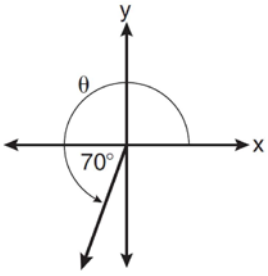

3)

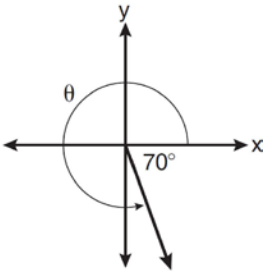

4)

227 The expression $\cos 4x \cos 3x + \sin 4x \sin 3x$ is equivalent to

- 1) $\sin x$
- 2) $\sin 7x$
- 3) $\cos x$
- 4) $\cos 7x$

228 The solution set of $\sqrt{3x + 16} = x + 2$ is

- 1) $\{-3, 4\}$
- 2) $\{-4, 3\}$
- 3) $\{3\}$
- 4) $\{-4\}$

229 Which arithmetic sequence has a common difference of 4?

- 1) $\{0, 4n, 8n, 12n, \dots\}$
- 2) $\{n, 4n, 16n, 64n, \dots\}$
- 3) $\{n + 1, n + 5, n + 9, n + 13, \dots\}$
- 4) $\{n + 4, n + 16, n + 64, n + 256, \dots\}$

230 Three marbles are to be drawn at random, without replacement, from a bag containing 15 red marbles, 10 blue marbles, and 5 white marbles. Which expression can be used to calculate the probability of drawing 2 red marbles and 1 white marble from the bag?

- 1) $\frac{{}^{15}C_2 \cdot {}^5C_1}{{}^{30}C_3}$
- 2) $\frac{{}^{15}P_2 \cdot {}^5P_1}{{}^{30}C_3}$
- 3) $\frac{{}^{15}C_2 \cdot {}^5C_1}{{}^{30}P_3}$
- 4) $\frac{{}^{15}P_2 \cdot {}^5P_1}{{}^{30}P_3}$

231 The discriminant of a quadratic equation is 24. The roots are

- 1) imaginary
- 2) real, rational, and equal
- 3) real, rational, and unequal
- 4) real, irrational, and unequal

232 A survey completed at a large university asked 2,000 students to estimate the average number of hours they spend studying each week. Every tenth student entering the library was surveyed. The data showed that the mean number of hours that students spend studying was 15.7 per week. Which characteristic of the survey could create a bias in the results?

- 1) the size of the sample
- 2) the size of the population
- 3) the method of analyzing the data
- 4) the method of choosing the students who were surveyed

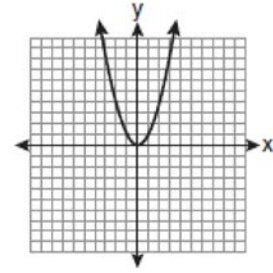

233 As shown in the table below, a person's target heart rate during exercise changes as the person gets older.

Age (years)	Target Heart Rate (beats per minute)
20	135
25	132
30	129
35	125
40	122
45	119
50	115

Which value represents the linear correlation coefficient, rounded to the *nearest thousandth*, between a person's age, in years, and that person's target heart rate, in beats per minute?

- 1) -0.999
- 2) -0.664
- 3) 0.998
- 4) 1.503

Which graph represents the function $f(x + 2)$?

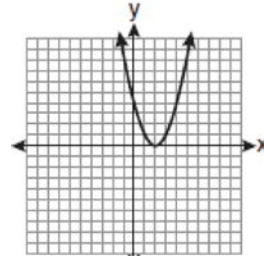

1)

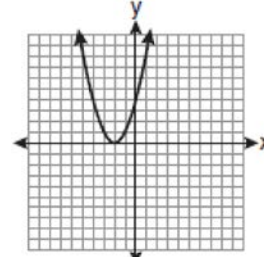

2)

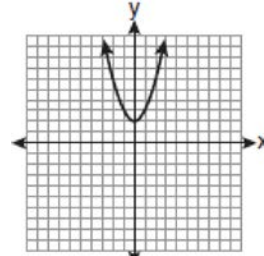

3)

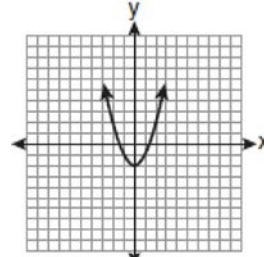

4)

234 The graph below shows the function $f(x)$.

Algebra 2/Trigonometry Multiple Choice Regents Exam Questions

www.jmap.org

235 What is the solution of the equation $2 \log_4(5x) = 3$?

- 1) 6.4
- 2) 2.56
- 3) $\frac{9}{5}$
- 4) $\frac{8}{5}$

236 A population of rabbits doubles every 60 days

according to the formula $P = 10(2)^{\frac{t}{60}}$, where P is the population of rabbits on day t . What is the value of t when the population is 320?

- 1) 240
- 2) 300
- 3) 660
- 4) 960

237 Which diagram represents a relation that is both one-to-one and onto?

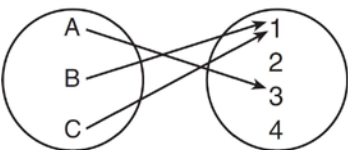
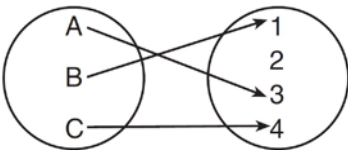
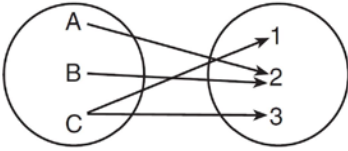
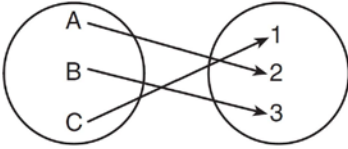
- 1) 
- 2) 
- 3) 
- 4) 

238 For which equation does the sum of the roots equal -3 and the product of the roots equal 2 ?

- 1) $x^2 + 2x - 3 = 0$
- 2) $x^2 - 3x + 2 = 0$
- 3) $2x^2 + 6x + 4 = 0$
- 4) $2x^2 - 6x + 4 = 0$

239 The table below displays the results of a survey regarding the number of pets each student in a class has. The average number of pets per student in this class is 2.

Number of Pets	0	1	2	3	4	5
Number of Students	4	6	10	0	k	2

What is the value of k for this table?

- 1) 9
- 2) 2
- 3) 8
- 4) 4

240 Expressed with a rational denominator and in simplest form, $\frac{x}{x - \sqrt{x}}$ is

- 1) $\frac{x^2 + x\sqrt{x}}{x^2 - x}$
- 2) $-\sqrt{x}$
- 3) $\frac{x + \sqrt{x}}{1 - x}$
- 4) $\frac{x + \sqrt{x}}{x - 1}$

241 The value of $\sin(180 + x)$ is equivalent to

- 1) $-\sin x$
- 2) $-\sin(90 - x)$
- 3) $\sin x$
- 4) $\sin(90 - x)$

242 The expression $\frac{a^2b^{-3}}{a^{-4}b^2}$ is equivalent to

- 1) $\frac{a^6}{b^5}$
- 2) $\frac{b^5}{a^6}$
- 3) $\frac{a^2}{b}$
- 4) $a^{-2}b^{-1}$

243 Which expression represents the third term in the expansion of $(2x^4 - y)^3$?

- 1) $-y^3$
- 2) $-6x^4y^2$
- 3) $6x^4y^2$
- 4) $2x^4y^2$

Algebra 2/Trigonometry 2 Point Regents Exam Questions

244 Simplify the expression $\frac{3x^{-4}y^5}{(2x^3y^{-7})^{-2}}$ and write the answer using only positive exponents.

249 Evaluate: $10 + \sum_{n=1}^5 (n^3 - 1)$

245 Find the sum and product of the roots of the equation $5x^2 + 11x - 3 = 0$.

250 Express the product of $\cos 30^\circ$ and $\sin 45^\circ$ in simplest radical form.

246 Write an equation for the graph of the trigonometric function shown below.

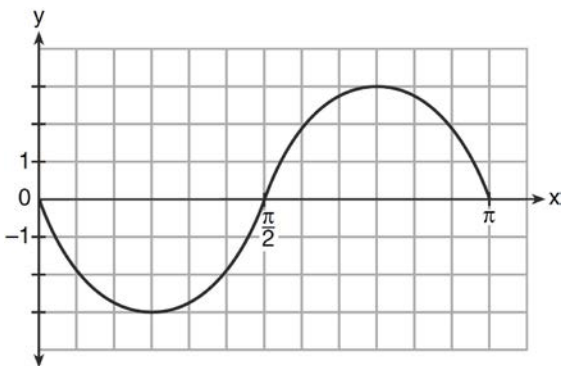

251 The graph of the equation $y = \left(\frac{1}{2}\right)^x$ has an asymptote. On the grid below, sketch the graph of $y = \left(\frac{1}{2}\right)^x$ and write the equation of this asymptote.

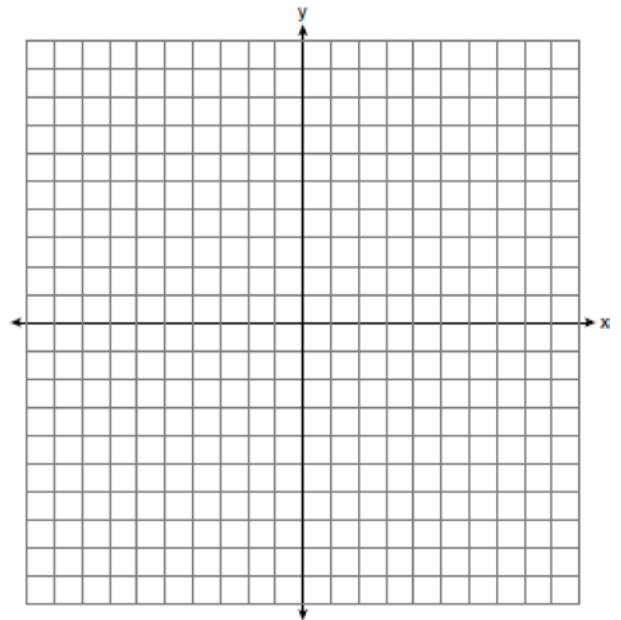

247 Express in simplest form: $\frac{\frac{1}{2} - \frac{4}{d}}{\frac{1}{d} + \frac{3}{2d}}$

248 Evaluate $e^{x \ln y}$ when $x = 3$ and $y = 2$.

- 252 The scores of one class on the Unit 2 mathematics test are shown in the table below.

Unit 2 Mathematics Test

Test Score	Frequency
96	1
92	2
84	5
80	3
76	6
72	3
68	2

Find the population standard deviation of these scores, to the *nearest tenth*.

- 253 A cup of soup is left on a countertop to cool. The table below gives the temperatures, in degrees Fahrenheit, of the soup recorded over a 10-minute period.

Time in Minutes (x)	Temperature in $^{\circ}\text{F}$ (y)
0	180.2
2	165.8
4	146.3
6	135.4
8	127.7
10	110.5

Write an exponential regression equation for the data, rounding all values to the *nearest thousandth*.

- 254 Determine the value of n in simplest form:

$$i^{13} + i^{18} + i^{31} + n = 0$$

- 255 Determine the solution of the inequality $|3 - 2x| \geq 7$. [The use of the grid below is optional.]

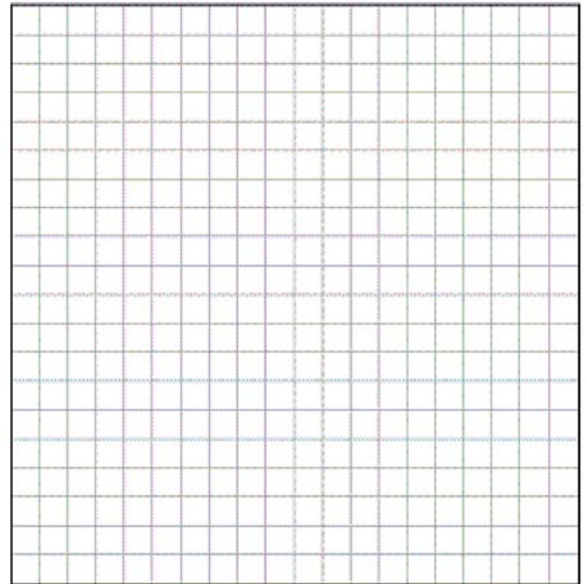

- 256 The formula for continuously compounded interest is $A = Pe^{rt}$, where A is the amount of money in the account, P is the initial investment, r is the interest rate, and t is the time in years. Using the formula, determine, to the *nearest dollar*, the amount in the account after 8 years if \$750 is invested at an annual rate of 3%.

- 257 Express the sum $7 + 14 + 21 + 28 + \dots + 105$ using sigma notation.

- 258 Solve for x : $\frac{4x}{x-3} = 2 + \frac{12}{x-3}$

Algebra 2/Trigonometry 2 Point Regents Exam Questions

www.jmap.org

259 The number of bacteria present in a Petri dish can be modeled by the function $N = 50e^{3t}$, where N is the number of bacteria present in the Petri dish after t hours. Using this model, determine, to the *nearest hundredth*, the number of hours it will take for N to reach 30,700.

260 Use the discriminant to determine all values of k that would result in the equation $x^2 - kx + 4 = 0$ having equal roots.

261 On a multiple-choice test, Abby randomly guesses on all seven questions. Each question has four choices. Find the probability, to the *nearest thousandth*, that Abby gets *exactly* three questions correct.

262 Determine the sum and the product of the roots of the equation $12x^2 + x - 6 = 0$.

263 Express $\left(\frac{2}{3}x - 1\right)^2$ as a trinomial.

264 If $f(x) = x^2 - 6$ and $g(x) = 2^x - 1$, determine the value of $(g \circ f)(-3)$.

265 Two sides of a parallelogram are 24 feet and 30 feet. The measure of the angle between these sides is 57° . Find the area of the parallelogram, to the *nearest square foot*.

266 Factor the expression $12t^8 - 75t^4$ completely.

267 Express in simplest form: $\sqrt[3]{\frac{a^6b^9}{-64}}$

268 Find the third term in the recursive sequence $a_{k+1} = 2a_k - 1$, where $a_1 = 3$.

269 On the unit circle shown in the diagram below, sketch an angle, in standard position, whose degree measure is 240° and find the exact value of $\sin 240^\circ$.

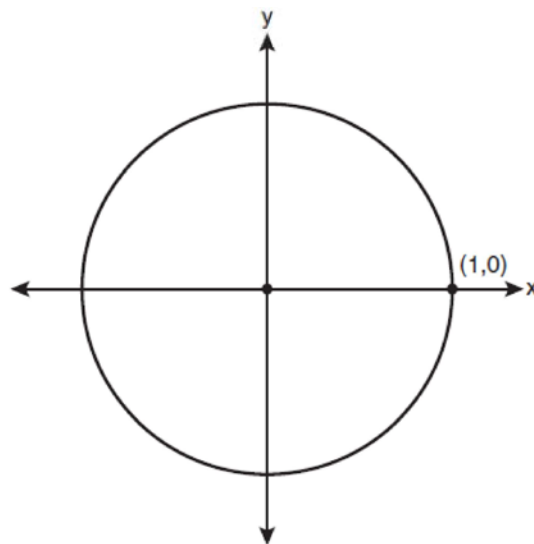

Algebra 2/Trigonometry 2 Point Regents Exam Questions

www.jmap.org

270 Solve algebraically for x : $\log_{27}(2x - 1) = \frac{4}{3}$

271 Express $\frac{\sqrt{108x^5y^8}}{\sqrt{6xy^5}}$ in simplest radical form.

272 Express $5\sqrt{3x^3} - 2\sqrt{27x^3}$ in simplest radical form.

273 On the axes below, for $-2 \leq x \leq 2$, graph $y = 2^{x+1} - 3$.

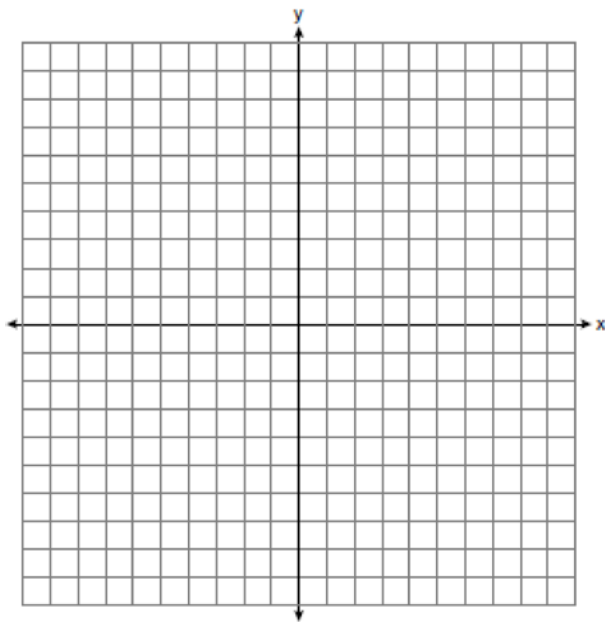

274 Convert 3 radians to degrees and express the answer to the nearest minute.

275 Express $\cos \theta (\sec \theta - \cos \theta)$, in terms of $\sin \theta$.

276 Find the first four terms of the recursive sequence defined below.

$$a_1 = -3$$

$$a_n = a_{(n-1)} - n$$

277 A circle shown in the diagram below has a center of $(-5, 3)$ and passes through point $(-1, 7)$.

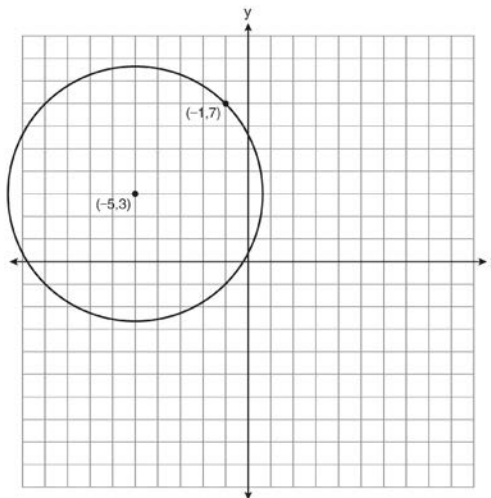

Write an equation that represents the circle.

Algebra 2/Trigonometry 2 Point Regents Exam Questions

www.jmap.org

278 Howard collected fish eggs from a pond behind his house so he could determine whether sunlight had an effect on how many of the eggs hatched. After he collected the eggs, he divided them into two tanks. He put both tanks outside near the pond, and he covered one of the tanks with a box to block out all sunlight. State whether Howard's investigation was an example of a controlled experiment, an observation, or a survey. Justify your response.

279 The heights, in inches, of 10 high school varsity basketball players are 78, 79, 79, 72, 75, 71, 74, 74, 83, and 71. Find the interquartile range of this data set.

280 Express $\frac{\cot x \sin x}{\sec x}$ as a single trigonometric function, in simplest form, for all values of x for which it is defined.

281 Solve algebraically for x : $16^{2x+3} = 64^{x+2}$

282 Express the product of $\left(\frac{1}{2}y^2 - \frac{1}{3}y\right)$ and $\left(12y + \frac{3}{5}\right)$ as a trinomial.

283 Starting with $\sin^2 A + \cos^2 A = 1$, derive the formula $\tan^2 A + 1 = \sec^2 A$.

284 Write an equation of the circle shown in the diagram below.

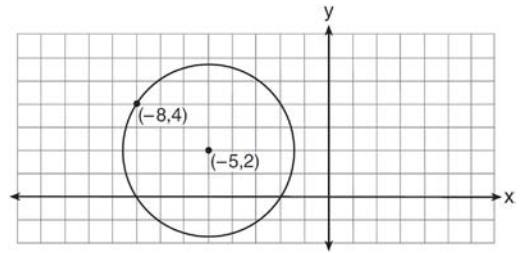

285 Factor completely: $10ax^2 - 23ax - 5a$

286 Find, to the *nearest minute*, the angle whose measure is 3.45 radians.

287 Matt places \$1,200 in an investment account earning an annual rate of 6.5%, compounded continuously. Using the formula $V = Pe^{rt}$, where V is the value of the account in t years, P is the principal initially invested, e is the base of a natural logarithm, and r is the rate of interest, determine the amount of money, to the *nearest cent*, that Matt will have in the account after 10 years.

288 Express $\frac{5}{3 - \sqrt{2}}$ with a rational denominator, in simplest radical form.

Algebra 2/Trigonometry 2 Point Regents Exam Questions

www.jmap.org

289 The two sides and included angle of a parallelogram are 18, 22, and 60° . Find its exact area in simplest form.

290 Assume that the ages of first-year college students are normally distributed with a mean of 19 years and standard deviation of 1 year. To the *nearest integer*, find the percentage of first-year college students who are between the ages of 18 years and 20 years, inclusive. To the *nearest integer*, find the percentage of first-year college students who are 20 years old or older.

291 For a given set of rectangles, the length is inversely proportional to the width. In one of these rectangles, the length is 12 and the width is 6. For this set of rectangles, calculate the width of a rectangle whose length is 9.

292 In a study of 82 video game players, the researchers found that the ages of these players were normally distributed, with a mean age of 17 years and a standard deviation of 3 years. Determine if there were 15 video game players in this study over the age of 20. Justify your answer.

293 Determine the sum of the first twenty terms of the sequence whose first five terms are 5, 14, 23, 32, 41.

294 Evaluate: $\sum_{n=1}^3 (-n^4 - n)$

295 Write an equation of the circle shown in the graph below.

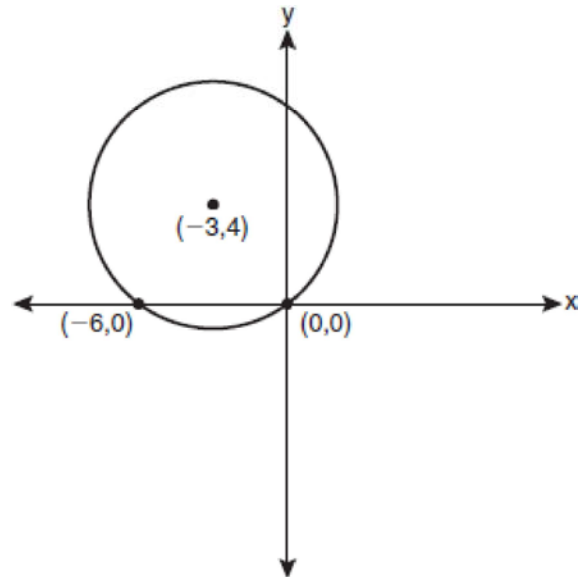

296 Write a quadratic equation such that the sum of its roots is 6 and the product of its roots is -27 .

297 Express the exact value of $\csc 60^\circ$, with a rational denominator.

298 Find the total number of different twelve-letter arrangements that can be formed using the letters in the word *PENNSYLVANIA*.

299 A blood bank needs twenty people to help with a blood drive. Twenty-five people have volunteered. Find how many different groups of twenty can be formed from the twenty-five volunteers.

300 If $f(x) = x^2 - 6$, find $f^{-1}(x)$.

301 The table below shows the number of new stores in a coffee shop chain that opened during the years 1986 through 1994.

Year	Number of New Stores
1986	14
1987	27
1988	48
1989	80
1990	110
1991	153
1992	261
1993	403
1994	681

Using $x = 1$ to represent the year 1986 and y to represent the number of new stores, write the exponential regression equation for these data. Round all values to the *nearest thousandth*.

302 The graph below represents the function $y = f(x)$.

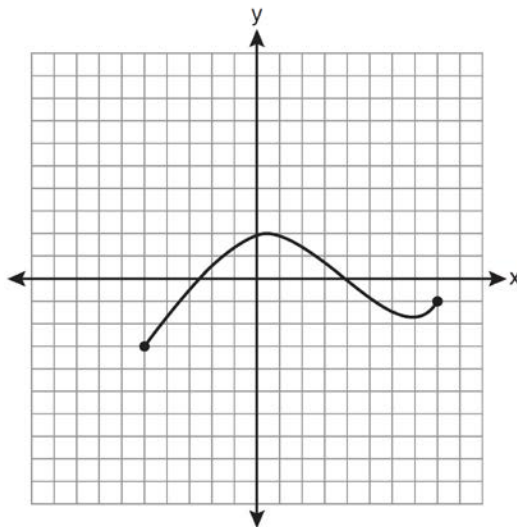

State the domain and range of this function.

303 Solve the equation $6x^2 - 2x - 3 = 0$ and express the answer in simplest radical form.

304 Find, to the *nearest tenth*, the radian measure of 216° .

305 A committee of 5 members is to be randomly selected from a group of 9 teachers and 20 students. Determine how many different committees can be formed if 2 members must be teachers and 3 members must be students.

Algebra 2/Trigonometry 2 Point Regents Exam Questions

www.jmap.org

306 If $g(x) = \left(ax\sqrt{1-x}\right)^2$, express $g(10)$ in simplest form.

307 Find, to the *nearest tenth of a degree*, the angle whose measure is 2.5 radians.

308 Find the number of possible different 10-letter arrangements using the letters of the word "STATISTICS."

309 If θ is an angle in standard position and its terminal side passes through the point $(-3, 2)$, find the exact value of $\csc \theta$.

310 Find, algebraically, the measure of the obtuse angle, to the *nearest degree*, that satisfies the equation $5 \csc \theta = 8$.

311 Solve the equation $2 \tan C - 3 = 3 \tan C - 4$ algebraically for all values of C in the interval $0^\circ \leq C < 360^\circ$.

312 Find the solution of the inequality $x^2 - 4x > 5$, algebraically.

313 Solve algebraically for x : $4 - \sqrt{2x - 5} = 1$

314 If $\sec(a + 15)^\circ = \csc(2a)^\circ$, find the smallest positive value of a , in degrees.

315 Determine the sum and the product of the roots of $3x^2 = 11x - 6$.

Algebra 2/Trigonometry 4 Point Regents Exam Questions

316 Solve algebraically for x : $\frac{1}{x+3} - \frac{2}{3-x} = \frac{4}{x^2-9}$

317 Write the binomial expansion of $(2x - 1)^5$ as a polynomial in simplest form.

318 The data collected by a biologist showing the growth of a colony of bacteria at the end of each hour are displayed in the table below.

Time, hour, (x)	Population (y)
0	250
1	330
2	580
3	800
4	1650
5	3000

Write an exponential regression equation to model these data. Round all values to the *nearest thousandth*. Assuming this trend continues, use this equation to estimate, to the nearest *ten*, the number of bacteria in the colony at the end of 7 hours.

319 A ranch in the Australian Outback is shaped like triangle ACE , with $m\angle A = 42$, $m\angle E = 103$, and $AC = 15$ miles. Find the area of the ranch, to the *nearest square mile*.

320 As shown in the diagram below, fire-tracking station A is 100 miles due west of fire-tracking station B . A forest fire is spotted at F , on a bearing 47° northeast of station A and 15° northeast of station B . Determine, to the *nearest tenth of a mile*, the distance the fire is from *both* station A and station B . [N represents due north.]

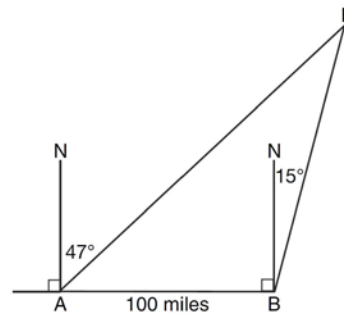

321 Graph the inequality $-3|6 - x| < -15$ for x . Graph the solution on the line below.



322 The probability that a professional baseball player will get a hit is $\frac{1}{3}$. Calculate the exact probability that he will get *at least* 3 hits in 5 attempts.

- 323 The diagram below shows the plans for a cell phone tower. A guy wire attached to the top of the tower makes an angle of 65 degrees with the ground. From a point on the ground 100 feet from the end of the guy wire, the angle of elevation to the top of the tower is 32 degrees. Find the height of the tower, to the *nearest foot*.

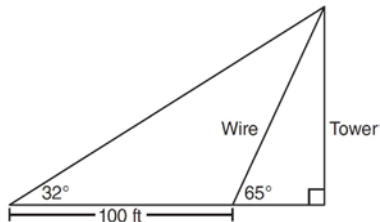

- 324 Express in simplest form: $\frac{4 - x^2}{x^2 + 7x + 12} \cdot \frac{2x - 4}{x + 3}$

- 325 The probability that the Stormville Sluggers will win a baseball game is $\frac{2}{3}$. Determine the probability, to the *nearest thousandth*, that the Stormville Sluggers will win *at least* 6 of their next 8 games.

- 326 Solve the equation below algebraically, and express the result in simplest radical form:

$$\frac{13}{x} = 10 - x$$

- 327 During a particular month, a local company surveyed all its employees to determine their travel times to work, in minutes. The data for all 15 employees are shown below.

25 55 40 65 29
45 59 35 25 37
52 30 8 40 55

Determine the number of employees whose travel time is within one standard deviation of the mean.

- 328 A study shows that 35% of the fish caught in a local lake had high levels of mercury. Suppose that 10 fish were caught from this lake. Find, to the *nearest tenth of a percent*, the probability that *at least* 8 of the 10 fish caught did *not* contain high levels of mercury.

- 329 Solve the equation $8x^3 + 4x^2 - 18x - 9 = 0$ algebraically for all values of x .

- 330 The members of a men's club have a choice of wearing black or red vests to their club meetings. A study done over a period of many years determined that the percentage of black vests worn is 60%. If there are 10 men at a club meeting on a given night, what is the probability, to the *nearest thousandth*, that *at least* 8 of the vests worn will be black?

- 331 A population of single-celled organisms was grown in a Petri dish over a period of 16 hours. The number of organisms at a given time is recorded in the table below.

Time, hrs (x)	Number of Organisms (y)
0	25
2	36
4	52
6	68
8	85
10	104
12	142
16	260

Determine the exponential regression equation model for these data, rounding all values to the *nearest ten-thousandth*. Using this equation, predict the number of single-celled organisms, to the *nearest whole number*, at the end of the 18th hour.

- 332 Solve algebraically for all values of x :
 $\log_{(x+4)}(17x-4) = 2$
- 333 Solve $2x^2 - 12x + 4 = 0$ by completing the square, expressing the result in simplest radical form.
- 334 Find all values of θ in the interval $0^\circ \leq \theta < 360^\circ$ that satisfy the equation $\sin 2\theta = \sin \theta$.

- 335 The table below shows the results of an experiment involving the growth of bacteria.

Time (x) (in minutes)	1	3	5	7	9	11
Number of Bacteria (y)	2	25	81	175	310	497

Write a power regression equation for this set of data, rounding all values to *three decimal places*. Using this equation, predict the bacteria's growth, to the *nearest integer*, after 15 minutes.

- 336 If $\log_4 x = 2.5$ and $\log_y 125 = -\frac{3}{2}$, find the numerical value of $\frac{x}{y}$, in simplest form.
- 337 In $\triangle ABC$, $m\angle A = 32$, $a = 12$, and $b = 10$. Find the measures of the missing angles and side of $\triangle ABC$. Round each measure to the *nearest tenth*.
- 338 Express as a single fraction the exact value of $\sin 75^\circ$.
- 339 The letters of any word can be rearranged. Carol believes that the number of different 9-letter arrangements of the word "TENNESSEE" is greater than the number of different 7-letter arrangements of the word "VERMONT." Is she correct? Justify your answer.

Algebra 2/Trigonometry 4 Point Regents Exam Questions

www.jmap.org

- 340 If $\tan A = \frac{2}{3}$ and $\sin B = \frac{5}{\sqrt{41}}$ and angles A and B are in Quadrant I, find the value of $\tan(A + B)$.
- 341 Ten teams competed in a cheerleading competition at a local high school. Their scores were 29, 28, 39, 37, 45, 40, 41, 38, 37, and 48. How many scores are within one population standard deviation from the mean? For these data, what is the interquartile range?
- 342 The measures of the angles between the resultant and two applied forces are 60° and 45° , and the magnitude of the resultant is 27 pounds. Find, to the *nearest pound*, the magnitude of each applied force.

Algebra 2/Trigonometry 6 Point Regents Exam Questions

343 In a triangle, two sides that measure 6 cm and 10 cm form an angle that measures 80° . Find, to the *nearest degree*, the measure of the smallest angle in the triangle.

344 Two forces of 25 newtons and 85 newtons acting on a body form an angle of 55° . Find the magnitude of the resultant force, to the *nearest hundredth of a newton*. Find the measure, to the *nearest degree*, of the angle formed between the resultant and the larger force.

345 Solve algebraically for x :
 $\sqrt{x^2 + x - 1} + 11x = 7x + 3$

346 Solve the following systems of equations algebraically: $5 = y - x$

$$4x^2 = -17x + y + 4$$

347 Solve algebraically for x : $\log_{x+3} \frac{x^3 + x - 2}{x} = 2$

348 Perform the indicated operations and simplify completely:

$$\frac{x^3 - 3x^2 + 6x - 18}{x^2 - 4x} \cdot \frac{2x - 4}{x^4 - 3x^3} \div \frac{x^2 + 2x - 8}{16 - x^2}$$

349 The temperature, T , of a given cup of hot chocolate after it has been cooling for t minutes can best be modeled by the function below, where T_0 is the temperature of the room and k is a constant.

$$\ln(T - T_0) = -kt + 4.718$$

A cup of hot chocolate is placed in a room that has a temperature of 68° . After 3 minutes, the temperature of the hot chocolate is 150° . Compute the value of k to the nearest thousandth. [Only an algebraic solution can receive full credit.] Using this value of k , find the temperature, T , of this cup of hot chocolate if it has been sitting in this room for a total of 10 minutes. Express your answer to the *nearest degree*. [Only an algebraic solution can receive full credit.]

350 Solve algebraically for all values of x :

$$81^{x^3 + 2x^2} = 27^{\frac{5x}{3}}$$

351 Solve algebraically for all values of x :

$$x^4 + 4x^3 + 4x^2 = -16x$$

Algebra 2/Trigonometry Multiple Choice Regents Exam Questions Answer Section

1 ANS: 2

Since the coefficient of t is greater than 0, $r > 0$.

PTS: 2 REF: 011303a2 STA: A2.S.8 TOP: Correlation Coefficient

2 ANS: 4 PTS: 2 REF: fall0925a2 STA: A2.S.10

TOP: Permutations

3 ANS: 4 PTS: 2 REF: 011201a2 STA: A2.S.2

TOP: Analysis of Data

4 ANS: 2

$$f^{-1}(x) = \log_4 x$$

PTS: 2 REF: fall0916a2 STA: A2.A.54 TOP: Graphing Logarithmic Functions

5 ANS: 1

$$2i^2 + 3i^3 = 2(-1) + 3(-i) = -2 - 3i$$

PTS: 2 REF: 081004a2 STA: A2.N.7 TOP: Imaginary Numbers

6 ANS: 3

$$3x^5 - 48x = 0$$

$$3x(x^4 - 16) = 0$$

$$3x(x^2 + 4)(x^2 - 4) = 0$$

$$3x(x^2 + 4)(x + 2)(x - 2) = 0$$

PTS: 2 REF: 011216a2 STA: A2.A.26 TOP: Solving Polynomial Equations

7 ANS: 3

$$\frac{3y}{2y-6} + \frac{9}{6-2y} = \frac{3y}{2y-6} - \frac{9}{2y-6} = \frac{3y-9}{2y-6} = \frac{3(y-3)}{2(y-3)} = \frac{3}{2}$$

PTS: 2 REF: 011325a2 STA: A2.A.16 TOP: Addition and Subtraction of Rationals

8 ANS: 3

$$S_8 = \frac{3(1 - (-4)^8)}{1 - (-4)} = \frac{196,605}{5} = -39,321$$

PTS: 2 REF: 061304a2 STA: A2.A.35 TOP: Summations

KEY: geometric

9 ANS: 3

$$2\pi \cdot \frac{5}{12} = \frac{10\pi}{12} = \frac{5\pi}{6}$$

PTS: 2 REF: 061125a2 STA: A2.M.1 TOP: Radian Measure

10 ANS: 3

$$a_n = 5(-2)^{n-1}$$

$$a_{15} = 5(-2)^{15-1} = 81,920$$

PTS: 2 REF: 011105a2 STA: A2.A.32 TOP: Sequences

11 ANS: 2

$$\frac{x^{-1} - 1}{x - 1} = \frac{\frac{1}{x} - 1}{x - 1} = \frac{\frac{1-x}{x}}{x-1} = \frac{-(x-1)}{x(x-1)} = -\frac{1}{x}$$

PTS: 2 REF: 081018a2 STA: A2.A.9 TOP: Negative Exponents

12 ANS: 2

$$(3 - 7i)(3 - 7i) = 9 - 21i - 21i + 49i^2 = 9 - 42i - 49 = -40 - 42i$$

PTS: 2 REF: fall0901a2 STA: A2.N.9

TOP: Multiplication and Division of Complex Numbers

13 ANS: 2 PTS: 2 REF: 061301a2 STA: A2.S.1

TOP: Analysis of Data

14 ANS: 3 PTS: 2 REF: 061306a2 STA: A2.A.72

TOP: Identifying the Equation of a Trigonometric Graph

15 ANS: 3

$$3x^3 - 5x^2 - 48x + 80$$

$$x^2(3x - 5) - 16(3x - 5)$$

$$(x^2 - 16)(3x - 5)$$

$$(x + 4)(x - 4)(3x - 5)$$

PTS: 2 REF: 011317a2 STA: A2.A.7 TOP: Factoring by Grouping

16 ANS: 1

$$5x + 29 = (x + 3)^2 \quad . \quad (-5) + 3 \text{ shows an extraneous solution.}$$

$$5x + 29 = x^2 + 6x + 9$$

$$0 = x^2 + x - 20$$

$$0 = (x + 5)(x - 4)$$

$$x = -5, 4$$

PTS: 2 REF: 061213a2 STA: A2.A.22 TOP: Solving Radicals

KEY: extraneous solutions

17 ANS: 3

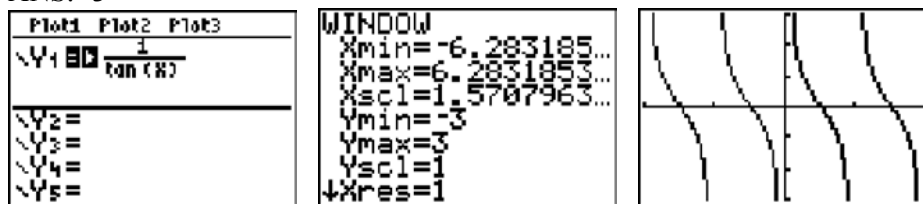

PTS: 2 REF: 011207a2 STA: A2.A.71 TOP: Graphing Trigonometric Functions

18 ANS: 4

(4) fails the horizontal line test. Not every element of the range corresponds to only one element of the domain.

PTS: 2 REF: fall0906a2 STA: A2.A.43 TOP: Defining Functions

19 ANS: 3

$${}^6C_3 \left(\frac{x}{2} \right)^3 (-2y)^3 = 20 \cdot \frac{x^3}{8} \cdot -8y^3 = -20x^3y^3$$

PTS: 2 REF: 061215a2 STA: A2.A.36 TOP: Binomial Expansions

20 ANS: 2

$${}^{15}C_8 = 6,435$$

PTS: 2 REF: 081012a2 STA: A2.S.11 TOP: Combinations

21 ANS: 2

$$x^3 + 3x^2 - 4x - 12$$

$$x^2(x + 3) - 4(x + 3)$$

$$(x^2 - 4)(x + 3)$$

$$(x + 2)(x - 2)(x + 3)$$

PTS: 2 REF: 061214a2 STA: A2.A.7 TOP: Factoring by Grouping

22 ANS: 4

$$9^{3x+1} = 27^{x+2}$$

$$(3^2)^{3x+1} = (3^3)^{x+2}$$

$$3^{6x+2} = 3^{3x+6}$$

$$6x + 2 = 3x + 6$$

$$3x = 4$$

$$x = \frac{4}{3}$$

PTS: 2 REF: 081008a2 STA: A2.A.27 TOP: Exponential Equations

KEY: common base not shown

23 ANS: 1

$$13^2 = 15^2 + 14^2 - 2(15)(14)\cos C$$

$$169 = 421 - 420\cos C$$

$$-252 = -420\cos C$$

$$\frac{252}{420} = \cos C$$

$$53 \approx C$$

PTS: 2

REF: 061110a2

STA: A2.A.73

TOP: Law of Cosines

KEY: find angle

24 ANS: 3

$$\frac{4}{-2} = -2$$

PTS: 2

REF: 011304a2

STA: A2.A.31

TOP: Sequences

25 ANS: 3

$$27r^{4-1} = 64$$

$$r^3 = \frac{64}{27}$$

$$r = \frac{4}{3}$$

PTS: 2

REF: 081025a2

STA: A2.A.31

TOP: Sequences

26 ANS: 1

$$6x - 7 \leq 5 \quad 6x - 7 \geq -5$$

$$6x \leq 12 \quad 6x \geq 2$$

$$x \leq 2 \quad x \geq \frac{1}{3}$$

PTS: 2

REF: fall0905a2

STA: A2.A.1

TOP: Absolute Value Inequalities

KEY: graph

27 ANS: 1

$$a_n = -\sqrt{5}(-\sqrt{2})^{n-1}$$

$$a_{15} = -\sqrt{5}(-\sqrt{2})^{15-1} = -\sqrt{5}(-\sqrt{2})^{14} = -\sqrt{5} \cdot 2^7 = -128\sqrt{5}$$

PTS: 2

REF: 061109a2

STA: A2.A.32

TOP: Sequences

28 ANS: 3

PTS: 2

REF: 061001a2

STA: A2.A.30

TOP: Sequences

29 ANS: 2

PTS: 2

REF: 011208a2

STA: A2.A.67

TOP: Proving Trigonometric Identities

30 ANS: 3

$$S_n = \frac{n}{2} [2a + (n-1)d] = \frac{19}{2} [2(3) + (19-1)7] = 1254$$

PTS: 2 REF: 011202a2 STA: A2.A.35 TOP: Summations
KEY: arithmetic

31 ANS: 3

$$\log 4m^2 = \log 4 + \log m^2 = \log 4 + 2 \log m$$

PTS: 2 REF: 061321a2 STA: A2.A.19 TOP: Properties of Logarithms
KEY: splitting logs

32 ANS: 1

$${}_{10}C_4 = 210$$

PTS: 2 REF: 061113a2 STA: A2.S.11 TOP: Combinations

33 ANS: 4

$$12x^4 + 10x^3 - 12x^2 = 2x^2(6x^2 + 5x - 6) = 2x^2(2x + 3)(3x - 2)$$

PTS: 2 REF: 061008a2 STA: A2.A.7 TOP: Factoring Polynomials
KEY: single variable

34 ANS: 3

$$\frac{3}{\sqrt{3a^2b}} = \frac{3}{a\sqrt{3b}} \cdot \frac{\sqrt{3b}}{\sqrt{3b}} = \frac{3\sqrt{3b}}{3ab} = \frac{\sqrt{3b}}{ab}$$

PTS: 2 REF: 081019a2 STA: A2.A.15 TOP: Rationalizing Denominators
KEY: index = 2

35 ANS: 1

$$\cos(A - B) = \left(\frac{5}{13}\right)\left(-\frac{3}{5}\right) + \left(\frac{12}{13}\right)\left(\frac{4}{5}\right) = -\frac{15}{65} + \frac{48}{65} = \frac{33}{65}$$

PTS: 2 REF: 011214a2 STA: A2.A.76 TOP: Angle Sum and Difference Identities
KEY: evaluating

36 ANS: 4

$$\frac{2\pi}{b} = 30$$

$$b = \frac{\pi}{15}$$

PTS: 2 REF: 011227a2 STA: A2.A.72
TOP: Identifying the Equation of a Trigonometric Graph

37 ANS: 2

$$\bar{x} \pm \sigma$$

$$153 \pm 22$$

$$131 - 175$$

PTS: 2 REF: 011307a2 STA: A2.S.5 TOP: Normal Distributions

KEY: interval

38 ANS: 2

$$\text{sum: } \frac{-b}{a} = \frac{4}{6} = \frac{2}{3}. \quad \text{product: } \frac{c}{a} = \frac{-12}{6} = -2$$

PTS: 2 REF: 011209a2 STA: A2.A.20 TOP: Roots of Quadratics

39 ANS: 2 PTS: 2 REF: 011315a2 STA: A2.A.55

TOP: Trigonometric Ratios

40 ANS: 1

$$\frac{9}{\sin A} = \frac{10}{\sin 70^\circ}. \quad 58^\circ + 70^\circ \text{ is possible. } 122^\circ + 70^\circ \text{ is not possible.}$$

$$A = 58$$

PTS: 2 REF: 011210a2 STA: A2.A.75 TOP: Law of Sines - The Ambiguous Case

41 ANS: 3

$$\text{period} = \frac{2\pi}{b} = \frac{2\pi}{3\pi} = \frac{2}{3}$$

PTS: 2 REF: 081026a2 STA: A2.A.70 TOP: Graphing Trigonometric Functions

KEY: recognize

42 ANS: 3

$$\frac{59.2}{\sin 74} = \frac{60.3}{\sin C} \quad 180 - 78.3 = 101.7$$

$$C \approx 78.3$$

PTS: 2 REF: 081006a2 STA: A2.A.75 TOP: Law of Sines - The Ambiguous Case

43 ANS: 3

$$\frac{4}{5 - \sqrt{13}} \cdot \frac{5 + \sqrt{13}}{5 + \sqrt{13}} = \frac{4(5 + \sqrt{13})}{25 - 13} = \frac{5 + \sqrt{13}}{3}$$

PTS: 2 REF: 061116a2 STA: A2.N.5 TOP: Rationalizing Denominators

44 ANS: 1

$$\frac{\sqrt{3} + 5}{\sqrt{3} - 5} \cdot \frac{\sqrt{3} + 5}{\sqrt{3} + 5} = \frac{3 + 5\sqrt{3} + 5\sqrt{3} + 25}{3 - 25} = \frac{28 + 10\sqrt{3}}{-22} = -\frac{14 + 5\sqrt{3}}{11}$$

PTS: 2 REF: 061012a2 STA: A2.N.5 TOP: Rationalizing Denominators

45 ANS: 1 PTS: 2 REF: 011310a2 STA: A2.S.9

TOP: Differentiating Permutations and Combinations

46 ANS: 3 PTS: 2 REF: 011119a2 STA: A2.A.52

TOP: Families of Functions

47 ANS: 2

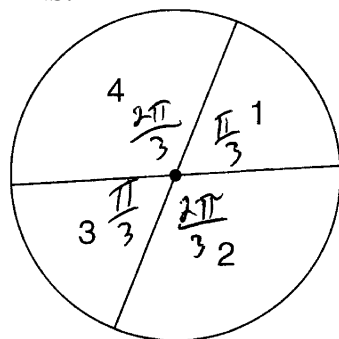

$$\frac{\frac{\pi}{3} + \frac{\pi}{3}}{2\pi} = \frac{\frac{2\pi}{3}}{2\pi} = \frac{1}{3}$$

PTS: 2 REF: 011108a2 STA: A2.S.13 TOP: Geometric Probability

48 ANS: 1 PTS: 2 REF: 011314a2 STA: A2.N.3

TOP: Operations with Polynomials

49 ANS: 2 PTS: 2 REF: 011225a2 STA: A2.A.43

TOP: Defining Functions

50 ANS: 2 PTS: 2 REF: 061108a2 STA: A2.A.52

TOP: Identifying the Equation of a Graph

51 ANS: 2

$$4^{2x+5} = 8^{3x}$$

$$\left(2^2\right)^{2x+5} = \left(2^3\right)^{3x}$$

$$2^{4x+10} = 2^{9x}$$

$$4x + 10 = 9x$$

$$10 = 5x$$

$$2 = x$$

PTS: 2 REF: 061105a2 STA: A2.A.27 TOP: Exponential Equations

KEY: common base not shown

52 ANS: 1 PTS: 2 REF: 061025a2 STA: A2.A.34

TOP: Sigma Notation

53 ANS: 4

$$7^2 = 3^2 + 5^2 - 2(3)(5)\cos A$$

$$49 = 34 - 30\cos A$$

$$15 = -30\cos A$$

$$-\frac{1}{2} = \cos A$$

$$120 = \cos A$$

PTS: 2 REF: 081017a2 STA: A2.A.73 TOP: Law of Cosines

KEY: angle, without calculator

54 ANS: 2 PTS: 2 REF: 061205a2 STA: A2.A.34
TOP: Sigma Notation

55 ANS: 3

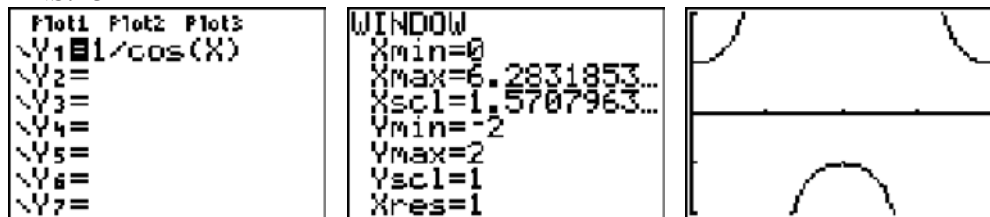

PTS: 2 REF: 061020a2 STA: A2.A.71 TOP: Graphing Trigonometric Functions

56 ANS: 2
 $\frac{8\pi}{5} \cdot \frac{180}{\pi} = 288$

PTS: 2 REF: 061302a2 STA: A2.M.2 TOP: Radian Measure
KEY: degrees

57 ANS: 3
 $6n^{-1} < 4n^{-1}$. Flip sign when multiplying each side of the inequality by n , since a negative number.

$$\frac{6}{n} < \frac{4}{n}$$

$$6 > 4$$

PTS: 2 REF: 061314a2 STA: A2.N.1 TOP: Negative and Fractional Exponents

58 ANS: 4
 $4ab\sqrt{2b} - 3a\sqrt{9b^2}\sqrt{2b} + 7ab\sqrt{6b} = 4ab\sqrt{2b} - 9ab\sqrt{2b} + 7ab\sqrt{6b} = -5ab\sqrt{2b} + 7ab\sqrt{6b}$

PTS: 2 REF: fall0918a2 STA: A2.A.14 TOP: Operations with Radicals
KEY: with variables | index = 2

59 ANS: 4
 ${}_3C_2 \left(\frac{5}{8}\right)^2 \left(\frac{3}{8}\right)^1 = \frac{225}{512}$

PTS: 2 REF: 011221a2 STA: A2.S.15 TOP: Binomial Probability
KEY: spinner

60 ANS: 2
 $\frac{2\pi}{b} = \frac{2\pi}{3}$

PTS: 2 REF: 061111a2 STA: A2.A.69 TOP: Properties of Graphs of Trigonometric Functions
KEY: period

61 ANS: 3

$$\begin{aligned}x + y &= 5 & . & \quad -5 + y = 5 \\y &= -x + 5 & & \quad y = 10\end{aligned}$$

$$(x + 3)^2 + (-x + 5 - 3)^2 = 53$$

$$x^2 + 6x + 9 + x^2 - 4x + 4 = 53$$

$$2x^2 + 2x - 40 = 0$$

$$x^2 + x - 20 = 0$$

$$(x + 5)(x - 4) = 0$$

$$x = -5, 4$$

PTS: 2 REF: 011302a2 STA: A2.A.3 TOP: Quadratic-Linear Systems
KEY: equations

62 ANS: 1 PTS: 2 REF: 061202a2 STA: A2.A.51
TOP: Domain and Range

63 ANS: 4 PTS: 2 REF: 011219a2 STA: A2.A.52
TOP: Properties of Graphs of Functions and Relations

64 ANS: 1

$$-420 \left(\frac{\pi}{180} \right) = -\frac{7\pi}{3}$$

PTS: 2 REF: 081002a2 STA: A2.M.2 TOP: Radian Measure
KEY: radians

65 ANS: 3
 ${}_8C_3 \cdot x^{8-3} \cdot (-2)^3 = 56x^5 \cdot (-8) = -448x^5$

PTS: 2 REF: 011308a2 STA: A2.A.36 TOP: Binomial Expansions
66 ANS: 3 PTS: 2 REF: 081027a2 STA: A2.A.44
TOP: Inverse of Functions KEY: equations

67 ANS: 3
 $68\% \times 50 = 34$

PTS: 2 REF: 081013a2 STA: A2.S.5 TOP: Normal Distributions
KEY: predict

68 ANS: 4 PTS: 2 REF: 011127a2 STA: A2.S.1
TOP: Analysis of Data

69 ANS: 3

$$\frac{-7 \pm \sqrt{7^2 - 4(2)(-3)}}{2(2)} = \frac{-7 \pm \sqrt{73}}{4}$$

PTS: 2 REF: 081009a2 STA: A2.A.25 TOP: Quadratic Formula
70 ANS: 3 PTS: 2 REF: 061224a2 STA: A2.A.63
TOP: Domain and Range

71 ANS: 1

$${}_9C_3 a^6 (-4b)^3 = -5376a^6 b^3$$

PTS: 2 REF: 061126a2 STA: A2.A.36 TOP: Binomial Expansions

72 ANS: 3

$$\begin{aligned} & \sqrt[3]{6a^4b^2} + \sqrt[3]{(27 \cdot 6)a^4b^2} \\ & a^3\sqrt[3]{6ab^2} + 3a^3\sqrt[3]{6ab^2} \\ & 4a^3\sqrt[3]{6ab^2} \end{aligned}$$

PTS: 2 REF: 011319a2 STA: A2.N.2 TOP: Operations with Radicals

73 ANS: 4

$$\frac{2\pi}{b} = \frac{2\pi}{\frac{1}{3}} = 6\pi$$

PTS: 2 REF: 061027a2 STA: A2.A.69
TOP: Properties of Graphs of Trigonometric Functions KEY: period

74 ANS: 2

$$\frac{x^{-1} + 1}{x + 1} = \frac{\frac{1}{x} + 1}{x + 1} = \frac{\frac{1 + x}{x}}{x + 1} = \frac{1}{x}$$

PTS: 2 REF: 011211a2 STA: A2.A.9 TOP: Negative Exponents

75 ANS: 1 PTS: 2 REF: 061210a2 STA: A2.A.9

TOP: Negative Exponents

76 ANS: 2

The binomials are conjugates, so use FL.

PTS: 2 REF: 011206a2 STA: A2.N.3 TOP: Operations with Polynomials

77 ANS: 4 PTS: 2 REF: 061120a2 STA: A2.A.19

TOP: Properties of Logarithms KEY: splitting logs

78 ANS: 3

1-Var Stats L1, L2	σx^2
	67.31102041

PTS: 2 REF: fall0924a2 STA: A2.S.4 TOP: Dispersion

KEY: range, quartiles, interquartile range, variance

79 ANS: 4

$$\sin(\theta + 90) = \sin \theta \cdot \cos 90 + \cos \theta \cdot \sin 90 = \sin \theta \cdot (0) + \cos \theta \cdot (1) = \cos \theta$$

PTS: 2

REF: 061309a2

STA: A2.A.76

TOP: Angle Sum and Difference Identities

KEY: identities

80 ANS: 3

$$b^2 - 4ac = (-10)^2 - 4(1)(25) = 100 - 100 = 0$$

PTS: 2

REF: 011102a2

STA: A2.A.2

TOP: Using the Discriminant

KEY: determine nature of roots given equation

81 ANS: 4

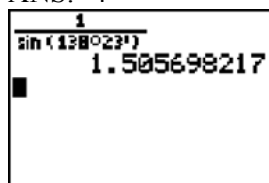

PTS: 2

REF: 061217a2

STA: A2.A.66

TOP: Determining Trigonometric Functions

82 ANS: 4

$$x = 2y. \quad y^2 - (3y)^2 + 32 = 0 \quad . \quad x = 3(-2) = -6$$

$$y^2 - 9y^2 = -32$$

$$-8y^2 = -32$$

$$y^2 = 4$$

$$y = \pm 2$$

PTS: 2

REF: 061312a2

STA: A2.A.3

TOP: Quadratic-Linear Systems

KEY: equations

83 ANS: 2

$$x^2 - x - 6 = 3x - 6$$

$$x^2 - 4x = 0$$

$$x(x - 4) = 0$$

$$x = 0, 4$$

PTS: 2

REF: 081015a2

STA: A2.A.3

TOP: Quadratic-Linear Systems

KEY: equations

84 ANS: 4

$$S_n = \frac{n}{2} [2a + (n-1)d] = \frac{21}{2} [2(18) + (21-1)2] = 798$$

PTS: 2

REF: 061103a2

STA: A2.A.35

TOP: Series

KEY: arithmetic

85 ANS: 3

PTS: 2

REF: fall0913a2

STA: A2.A.65

TOP: Graphing Trigonometric Functions

86 ANS: 1

$$2 \cdot \frac{180}{\pi} = \frac{360}{\pi}$$

PTS: 2 REF: 011220a2 STA: A2.M.2 TOP: Radian Measure
KEY: degrees

87 ANS: 3 PTS: 2 REF: 011104a2 STA: A2.A.64
TOP: Using Inverse Trigonometric Functions KEY: unit circle

88 ANS: 4 PTS: 2 REF: 061207a2 STA: A2.A.19
TOP: Properties of Logarithms KEY: antilogarithms

89 ANS: 4
 ${}_{15}C_5 = 3,003$. ${}_{25}C_5 = {}_{25}C_{20} = 53,130$. ${}_{25}C_{15} = 3,268,760$.

PTS: 2 REF: 061227a2 STA: A2.S.11 TOP: Combinations

90 ANS: 3

$$75000 = 25000e^{.0475t}$$

$$3 = e^{.0475t}$$

$$\ln 3 = \ln e^{.0475t}$$

$$\frac{\ln 3}{.0475} = \frac{.0475t \cdot \ln e}{.0475}$$

$$23.1 \approx t$$

PTS: 2 REF: 061117a2 STA: A2.A.6 TOP: Exponential Growth

91 ANS: 1

$$2x - 1 > 5 \quad 2x - 1 < -5$$

$$2x > 6 \quad 2x > -4$$

$$x > 3 \quad x < -2$$

PTS: 2 REF: 061307a2 STA: A2.A.1 TOP: Absolute Value Inequalities
KEY: graph

92 ANS: 1

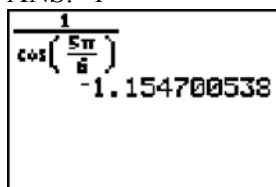

The image shows a calculator display with the expression $\frac{1}{\cos\left(\frac{5\pi}{6}\right)}$ and the numerical result -1.154700538 .

PTS: 2 REF: 011203a2 STA: A2.A.66 TOP: Determining Trigonometric Functions

93 ANS: 4 PTS: 2 REF: 061206a2 STA: A2.A.60
TOP: Unit Circle

94 ANS: 3
 $x = 5^4 = 625$

PTS: 2 REF: 061106a2 STA: A2.A.28 TOP: Logarithmic Equations
KEY: basic

95 ANS: 4 PTS: 2 REF: 061112a2 STA: A2.A.39
TOP: Domain and Range KEY: real domain

96 ANS: 4 PTS: 2 REF: 061101a2 STA: A2.S.1
TOP: Analysis of Data

97 ANS: 1
The binomials are conjugates, so use FL.

PTS: 2 REF: 061201a2 STA: A2.N.3 TOP: Operations with Polynomials

98 ANS: 2
 $\cos(-305^\circ + 360^\circ) = \cos(55^\circ)$

PTS: 2 REF: 061104a2 STA: A2.A.57 TOP: Reference Angles

99 ANS: 4
$$\cos 2A = 1 - 2\sin^2 A = 1 - 2\left(\frac{1}{3}\right)^2 = 1 - \frac{2}{9} = \frac{7}{9}$$

PTS: 2 REF: 011311a2 STA: A2.A.77 TOP: Double Angle Identities
KEY: evaluating

100 ANS: 1 PTS: 2 REF: 081022a2 STA: A2.A.46
TOP: Transformations with Functions and Relations

101 ANS: 2
 $x^2 - 2x + y^2 + 6y = -3$
 $x^2 - 2x + 1 + y^2 + 6y + 9 = -3 + 1 + 9$
 $(x - 1)^2 + (y + 3)^2 = 7$

PTS: 2 REF: 061016a2 STA: A2.A.47 TOP: Equations of Circles

102 ANS: 4
 $\frac{10}{4} = 2.5$

PTS: 2 REF: 011217a2 STA: A2.A.29 TOP: Sequences

103 ANS: 1

$$\cos K = \frac{5}{6}$$

$$K = \cos^{-1} \frac{5}{6}$$

$$K \approx 33^\circ 33'$$

PTS: 2 REF: 061023a2 STA: A2.A.55 TOP: Trigonometric Ratios

104 ANS: 1 PTS: 2 REF: 011320a2 STA: A2.A.72
TOP: Identifying the Equation of a Trigonometric Graph

105 ANS: 1

$$\sqrt{12^2 - 6^2} = \sqrt{108} = \sqrt{36} \sqrt{3} = 6\sqrt{3}. \cot J = \frac{A}{O} = \frac{6}{6\sqrt{3}} \cdot \frac{\sqrt{3}}{\sqrt{3}} = \frac{\sqrt{3}}{3}$$

PTS: 2 REF: 011120a2 STA: A2.A.55 TOP: Trigonometric Ratios
106 ANS: 4 PTS: 2 REF: 011111a2 STA: A2.N.8
TOP: Conjugates of Complex Numbers

107 ANS: 2

$$K = \frac{1}{2} (10)(18)\sin 120 = 45\sqrt{3} \approx 78$$

PTS: 2 REF: fall0907a2 STA: A2.A.74 TOP: Using Trigonometry to Find Area
KEY: basic

108 ANS: 3

$$S = \frac{-b}{a} = \frac{-(-3)}{4} = \frac{3}{4}. P = \frac{c}{a} = \frac{-8}{4} = -2$$

PTS: 2 REF: fall0912a2 STA: A2.A.21 TOP: Roots of Quadratics
KEY: basic

109 ANS: 2

$$\frac{10}{\sin 35} = \frac{13}{\sin B} \quad . \quad 35 + 48 < 180$$

$$B \approx 48, 132 \quad 35 + 132 < 180$$

PTS: 2 REF: 011113a2 STA: A2.A.75 TOP: Law of Sines - The Ambiguous Case
110 ANS: 3
 $K = (10)(18)\sin 46 \approx 129$

PTS: 2 REF: 081021a2 STA: A2.A.74 TOP: Using Trigonometry to Find Area
KEY: parallelograms

111 ANS: 2 PTS: 2 REF: 061322a2 STA: A2.A.73
TOP: Law of Sines KEY: side, without calculator

112 ANS: 3 PTS: 2 REF: 061127a2 STA: A2.S.6
TOP: Regression

113 ANS: 3

$$\frac{3^{-2}}{(-2)^{-3}} = \frac{\frac{1}{9}}{-\frac{1}{8}} = -\frac{8}{9}$$

PTS: 2 REF: 061003a2 STA: A2.N.1 TOP: Negative and Fractional Exponents
114 ANS: 4 PTS: 2 REF: 011124a2 STA: A2.A.18
TOP: Evaluating Logarithmic Expressions

115 ANS: 4

$$\frac{13}{\sin 40} = \frac{20}{\sin M} \cdot 81 + 40 < 180. (180 - 81) + 40 < 180$$

$$M \approx 81$$

PTS: 2 REF: 061327a2 STA: A2.A.75 TOP: Law of Sines - The Ambiguous Case

116 ANS: 1 PTS: 2 REF: 011112a2 STA: A2.A.64

TOP: Using Inverse Trigonometric Functions KEY: advanced

117 ANS: 4

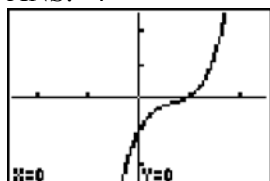

PTS: 2 REF: 061222a2 STA: A2.A.50 TOP: Solving Polynomial Equations

118 ANS: 4 PTS: 2 REF: 061124a2 STA: A2.S.3

TOP: Average Known with Missing Data

119 ANS: 1

$8 \times 8 \times 7 \times 1 = 448$. The first digit cannot be 0 or 5. The second digit cannot be 5 or the same as the first digit. The third digit cannot be 5 or the same as the first or second digit.

PTS: 2 REF: 011125a2 STA: A2.S.10 TOP: Permutations

120 ANS: 1

$$\sqrt[4]{16x^2y^7} = 16^{\frac{1}{4}} x^{\frac{2}{4}} y^{\frac{7}{4}} = 2x^{\frac{1}{2}} y^{\frac{7}{4}}$$

PTS: 2 REF: 061107a2 STA: A2.A.11 TOP: Radicals as Fractional Exponents

121 ANS: 3

(1) and (4) fail the horizontal line test and are not one-to-one. Not every element of the range corresponds to only one element of the domain. (2) fails the vertical line test and is not a function. Not every element of the domain corresponds to only one element of the range.

PTS: 2 REF: 081020a2 STA: A2.A.43 TOP: Defining Functions

122 ANS: 2 PTS: 2 REF: 061218a2 STA: A2.A.43

TOP: Defining Functions

123 ANS: 1 PTS: 2 REF: 011313a2 STA: A2.A.39

TOP: Domain and Range KEY: real domain

124 ANS: 1

$$20(-2) = x(-2x + 2)$$

$$-40 = -2x^2 + 2x$$

$$2x^2 - 2x - 40 = 0$$

$$x^2 - x - 20 = 0$$

$$(x + 4)(x - 5) = 0$$

$$x = -4, 5$$

PTS: 2

REF: 011321a2

STA: A2.A.5

TOP: Inverse Variation

125 ANS: 3

PTS: 2

REF: 061007a2

STA: A2.S.9

TOP: Differentiating Permutations and Combinations

126 ANS: 4

$$8^{3k+4} = 4^{2k-1}$$

$$(2^3)^{3k+4} = (2^2)^{2k-1}$$

$$2^{9k+12} = 2^{4k-2}$$

$$9k + 12 = 4k - 2$$

$$5k = -14$$

$$k = -\frac{14}{5}$$

PTS: 2

REF: 011309a2

STA: A2.A.27

TOP: Exponential Equations

KEY: common base not shown

127 ANS: 1

common difference is 2. $b_n = x + 2n$

$$10 = x + 2(1)$$

$$8 = x$$

PTS: 2

REF: 081014a2

STA: A2.A.29

TOP: Sequences

128 ANS: 2

$$\tan 30 = \frac{\sqrt{3}}{3}. \text{ Arc cos } \frac{\sqrt{3}}{k} = 30$$

$$\frac{\sqrt{3}}{k} = \cos 30$$

$$k = 2$$

PTS: 2

REF: 061323a2

STA: A2.A.64

TOP: Using Inverse Trigonometric Functions

KEY: advanced

129 ANS: 2

PTS: 2

REF: 061122a2

STA: A2.A.24

TOP: Completing the Square

130 ANS: 4

$$b^2 - 4ac = 3^2 - 4(9)(-4) = 9 + 144 = 153$$

PTS: 2 REF: 081016a2 STA: A2.A.2 TOP: Using the Discriminant
KEY: determine nature of roots given equation

131 ANS: 3

$$34.1\% + 19.1\% = 53.2\%$$

PTS: 2 REF: 011212a2 STA: A2.S.5 TOP: Normal Distributions
KEY: probability

132 ANS: 4

TOP: Defining Functions

PTS: 2

REF: 011101a2

STA: A2.A.38

KEY: graphs

133 ANS: 3

$$1000 = 500e^{.05t}$$

$$2 = e^{.05t}$$

$$\ln 2 = \ln e^{.05t}$$

$$\frac{\ln 2}{.05} = \frac{.05t \cdot \ln e}{.05}$$

$$13.9 \approx t$$

PTS: 2 REF: 061313a2 STA: A2.A.6 TOP: Exponential Growth

134 ANS: 4

TOP: Determining Trigonometric Functions

PTS: 1

REF: 011312a2

STA: A2.A.56

KEY: degrees, common angles

135 ANS: 3

$$f(4) = \frac{1}{2}(4) - 3 = -1. \quad g(-1) = 2(-1) + 5 = 3$$

PTS: 2 REF: fall0902a2 STA: A2.A.42 TOP: Compositions of Functions
KEY: numbers

136 ANS: 2

$$\log x^2 = \log 3a + \log 2a$$

$$2 \log x = \log 6a^2$$

$$\log x = \frac{\log 6}{2} + \frac{\log a^2}{2}$$

$$\log x = \frac{1}{2} \log 6 + \frac{2 \log a}{2}$$

$$\log x = \frac{1}{2} \log 6 + \log a$$

PTS: 2 REF: 011224a2 STA: A2.A.19 TOP: Properties of Logarithms
KEY: splitting logs

137 ANS: 2

$$x^2 + 2 = 6x$$

$$x^2 - 6x = -2$$

$$x^2 - 6x + 9 = -2 + 9$$

$$(x - 3)^2 = 7$$

PTS: 2

REF: 011116a2

STA: A2.A.24

TOP: Completing the Square

138 ANS: 2

$$\log 9 - \log 20$$

$$\log 3^2 - \log(10 \cdot 2)$$

$$2 \log 3 - (\log 10 + \log 2)$$

$$2b - (1 + a)$$

$$2b - a - 1$$

PTS: 2

REF: 011326a2

STA: A2.A.19

TOP: Properties of Logarithms

KEY: expressing logs algebraically

139 ANS: 4

$$y - 2 \sin \theta = 3$$

$$y = 2 \sin \theta + 3$$

$$f(\theta) = 2 \sin \theta + 3$$

PTS: 2

REF: fall0927a2

STA: A2.A.40

TOP: Functional Notation

140 ANS: 3

n	0	1	2	Σ
$n^2 + 2^n$	$0^2 + 2^0 = 1$	$1^2 + 2^1 = 3$	$2^2 + 2^2 = 8$	12

$$2 \times 12 = 24$$

PTS: 2

REF: fall0911a2

STA: A2.N.10

TOP: Sigma Notation

KEY: basic

141 ANS: 1

```

Plot1 Plot2 Plot3
Y1=1/sin(X)
Y2=
Y3=
Y4=
Y5=
Y6=
Y7=

```

```

WINDOW
Xmin=-3.141592
Xmax=3.1415926...
Xscl=0
Ymin=-10
Ymax=10
Yscl=1
Xres=1

```

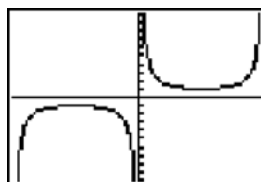

PTS: 2

REF: 011123a2

STA: A2.A.71

TOP: Graphing Trigonometric Functions

142 ANS: 3

$$-\sqrt{2} \sec x = 2$$

$$\sec x = -\frac{2}{\sqrt{2}}$$

$$\cos x = -\frac{\sqrt{2}}{2}$$

$$x = 135, 225$$

PTS: 2 REF: 011322a2 STA: A2.A.68 TOP: Trigonometric Equations
KEY: reciprocal functions

143 ANS: 2 PTS: 2 REF: 061011a2 STA: A2.A.10
TOP: Fractional Exponents as Radicals

144 ANS: 4

$$\frac{2x+4}{\sqrt{x+2}} \cdot \frac{\sqrt{x+2}}{\sqrt{x+2}} = \frac{2(x+2)\sqrt{x+2}}{x+2} = 2\sqrt{x+2}$$

PTS: 2 REF: 011122a2 STA: A2.A.15 TOP: Rationalizing Denominators
KEY: index = 2

145 ANS: 2

$$\left(\frac{w^{-5}}{w^{-9}} \right)^{\frac{1}{2}} = (w^4)^{\frac{1}{2}} = w^2$$

PTS: 2 REF: 081011a2 STA: A2.A.8 TOP: Negative and Fractional Exponents

146 ANS: 3

$$\left(\frac{2}{3} \right)^2 + \cos^2 A = 1 \quad \sin 2A = 2 \sin A \cos A$$

$$\cos^2 A = \frac{5}{9} \quad = 2 \left(\frac{2}{3} \right) \left(\frac{\sqrt{5}}{3} \right)$$

$$\cos A = +\frac{\sqrt{5}}{3}, \sin A \text{ is acute.} \quad = \frac{4\sqrt{5}}{9}$$

PTS: 2 REF: 011107a2 STA: A2.A.77 TOP: Double Angle Identities
KEY: evaluating

147 ANS: 2

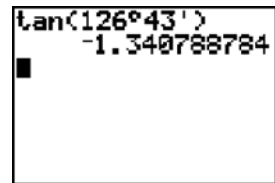

PTS: 2 REF: 061115a2 STA: A2.A.66 TOP: Determining Trigonometric Functions

- 148 ANS: 4 PTS: 2 REF: fall0908a2 STA: A2.A.38
TOP: Defining Functions KEY: graphs
- 149 ANS: 2
 $\frac{11\pi}{12} \cdot \frac{180}{\pi} = 165$
- PTS: 2 REF: 061002a2 STA: A2.M.2 TOP: Radian Measure
KEY: degrees
- 150 ANS: 1 PTS: 2 REF: 061317a2 STA: A2.S.9
TOP: Differentiating Permutations and Combinations
- 151 ANS: 2 PTS: 2 REF: 061021a2 STA: A2.S.8
TOP: Correlation Coefficient
- 152 ANS: 3
 $42 = \frac{1}{2}(a)(8)\sin 61$
 $42 \approx 3.5a$
 $12 \approx a$
- PTS: 2 REF: 011316a2 STA: A2.A.74 TOP: Using Trigonometry to Find Area
KEY: basic
- 153 ANS: 3 PTS: 2 REF: 011305a2 STA: A2.A.38
TOP: Defining Functions KEY: graphs
- 154 ANS: 4 PTS: 2 REF: 061005a2 STA: A2.A.50
TOP: Solving Polynomial Equations
- 155 ANS: 2
 $x^3 + x^2 - 2x = 0$
 $x(x^2 + x - 2) = 0$
 $x(x + 2)(x - 1) = 0$
 $x = 0, -2, 1$
- PTS: 2 REF: 011103a2 STA: A2.A.26 TOP: Solving Polynomial Equations
- 156 ANS: 1
 ${}_5C_3(3x)^2(-2)^3 = 10 \cdot 9x^2 \cdot -8 = -720x^2$
- PTS: 2 REF: fall0919a2 STA: A2.A.36 TOP: Binomial Expansions

157 ANS: 3

$$x^2 - 3x - 10 > 0 \quad \text{or}$$

$$(x - 5)(x + 2) > 0 \quad x - 5 < 0 \text{ and } x + 2 < 0$$

$$x - 5 > 0 \text{ and } x + 2 > 0 \quad x < 5 \text{ and } x < -2$$

$$x > 5 \text{ and } x > -2 \quad x < -2$$

$$x > 5$$

PTS: 2 REF: 011115a2 STA: A2.A.4 TOP: Quadratic Inequalities

KEY: one variable

158 ANS: 3 PTS: 2 REF: 061308ge STA: A2.A.51

TOP: Domain and Range

159 ANS: 1

$$\cos^2 \theta - \cos 2\theta = \cos^2 \theta - (\cos^2 \theta - \sin^2 \theta) = \sin^2 \theta$$

PTS: 2 REF: 061024a2 STA: A2.A.77 TOP: Double Angle Identities

KEY: simplifying

160 ANS: 2 PTS: 2 REF: 081010a2 STA: A2.A.55

TOP: Trigonometric Ratios

161 ANS: 1

$$10 \cdot \frac{3}{2} = \frac{3}{5} p$$

$$15 = \frac{3}{5} p$$

$$25 = p$$

PTS: 2 REF: 011226a2 STA: A2.A.5 TOP: Inverse Variation

162 ANS: 2 PTS: 2 REF: 011213a2 STA: A2.N.8

TOP: Conjugates of Complex Numbers

163 ANS: 1 PTS: 2 REF: 061211a2 STA: A2.A.54

TOP: Graphing Logarithmic Functions

164 ANS: 1

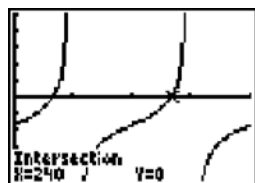

$$\tan \theta - \sqrt{3} = 0$$

$$\tan \theta = \sqrt{3}$$

$$\theta = \tan^{-1} \sqrt{3}$$

$$\theta = 60, 240$$

PTS: 2 REF: fall0903a2 STA: A2.A.68 TOP: Trigonometric Equations

KEY: basic

165 ANS: 3

$$4^{x^2+4x} = 2^{-6} \quad 2x^2 + 8x = -6$$

$$(2^2)^{x^2+4x} = 2^{-6} \quad 2x^2 + 8x + 6 = 0$$

$$2^{2x^2+8x} = 2^{-6} \quad x^2 + 4x + 3 = 0$$

$$(x+3)(x+1) = 0$$

$$x = -3 \quad x = -1$$

PTS: 2 REF: 061015a2 STA: A2.A.27 TOP: Exponential Equations
KEY: common base shown

166 ANS: 3

$$\sqrt[3]{4^3 a^{15}} = 4a^5 \sqrt[3]{a}$$

PTS: 2 REF: 061204a2 STA: A2.A.13 TOP: Simplifying Radicals
KEY: index > 2

167 ANS: 4

$$4 + 3(2-x) + 3(3-x) + 3(4-x) + 3(5-x)$$

$$4 + 6 - 3x + 9 - 3x + 12 - 3x + 15 - 3x$$

$$46 - 12x$$

PTS: 2 REF: 061315a2 STA: A2.N.10 TOP: Sigma Notation
KEY: basic

168 ANS: 1

$$\frac{1}{2}(7.4)(3.8)\sin 126 \approx 11.4$$

PTS: 2 REF: 011218a2 STA: A2.A.74 TOP: Using Trigonometry to Find Area
KEY: basic

169 ANS: 3 PTS: 2 REF: 081007a2 STA: A2.A.64
TOP: Using Inverse Trigonometric Functions KEY: basic

170 ANS: 4 PTS: 2 REF: 061318a2 STA: A2.A.49
TOP: Equations of Circles

171 ANS: 2

$$\frac{\frac{x}{4} - \frac{1}{x}}{\frac{1}{2x} + \frac{1}{4}} = \frac{\frac{x^2-4}{4x}}{\frac{2x+4}{8x}} = \frac{(x+2)(x-2)}{4x} \times \frac{8x}{2(x+2)} = x-2$$

PTS: 2 REF: fall0920a2 STA: A2.A.17 TOP: Complex Fractions

172 ANS: 4

$$6x - x^3 - x^2 = -x(x^2 + x - 6) = -x(x+3)(x-2)$$

PTS: 2 REF: fall0917a2 STA: A2.A.7 TOP: Factoring Polynomials
KEY: single variable

173 ANS: 1 PTS: 2 REF: 061019a2 STA: A2.N.7
TOP: Imaginary Numbers

174 ANS: 2

$$\sin S = \frac{8}{17}$$

$$S = \sin^{-1} \frac{8}{17}$$

$$S \approx 28^\circ 4'$$

PTS: 2 REF: 061311a2 STA: A2.A.55 TOP: Trigonometric Ratios

175 ANS: 3 PTS: 2 REF: fall0923a2 STA: A2.A.39

TOP: Domain and Range KEY: real domain

176 ANS: 2 PTS: 2 REF: 081024a2 STA: A2.N.8

TOP: Conjugates of Complex Numbers

177 ANS: 1 PTS: 2 REF: 061324a2 STA: A2.A.9

TOP: Negative Exponents

178 ANS: 1 PTS: 2 REF: 061004a2 STA: A2.A.52

TOP: Identifying the Equation of a Graph

179 ANS: 2

The roots are $-1, 2, 3$.

PTS: 2 REF: 081023a2 STA: A2.A.50 TOP: Solving Polynomial Equations

180 ANS: 1 PTS: 2 REF: 061018a2 STA: A2.A.22

TOP: Solving Radicals KEY: extraneous solutions

181 ANS: 1 PTS: 2 REF: 061316a2 STA: A2.S.8

TOP: Correlation Coefficient

182 ANS: 3

If $\csc P > 0$, $\sin P > 0$. If $\cot P < 0$ and $\sin P > 0$, $\cos P < 0$

PTS: 2 REF: 061320a2 STA: A2.A.60 TOP: Finding the Terminal Side of an Angle

183 ANS: 2 PTS: 2 REF: 011301a2 STA: A2.A.53

TOP: Graphing Exponential Functions

184 ANS: 2 PTS: 2 REF: 011222a2 STA: A2.A.39

TOP: Domain and Range KEY: real domain

185 ANS: 3 PTS: 2 REF: 061119a2 STA: A2.A.65

TOP: Graphing Trigonometric Functions

186 ANS: 2 PTS: 2 REF: 011126a2 STA: A2.A.49

TOP: Equations of Circles

187 ANS: 3 PTS: 2 REF: 061022a2 STA: A2.A.63

TOP: Domain and Range

188 ANS: 4

$$x^{-\frac{2}{5}} = \frac{1}{x^{\frac{2}{5}}} = \frac{1}{\sqrt[5]{x^2}}$$

PTS: 2 REF: 011118a2 STA: A2.A.10 TOP: Fractional Exponents as Radicals

189 ANS: 2 PTS: 2 REF: 081003a2 STA: A2.A.51

TOP: Domain and Range

190 ANS: 3

$$\sqrt{-300} = \sqrt{100} \sqrt{-1} \sqrt{3}$$

PTS: 2 REF: 061006a2 STA: A2.N.6 TOP: Square Roots of Negative Numbers

191 ANS: 4

$$g\left(\frac{1}{2}\right) = \frac{1}{\frac{1}{2}} = 2. \quad f(2) = 4(2) - 2^2 = 4$$

PTS: 2 REF: 011204a2 STA: A2.A.42 TOP: Compositions of Functions

KEY: numbers

192 ANS: 2 PTS: 2 REF: 061216a2 STA: A2.A.42

TOP: Compositions of Functions KEY: variables

193 ANS: 2

$$2^2 \cdot 3 = 12 \quad 6^2 d = 12$$

$$4^2 \cdot \frac{3}{4} = 12 \quad 36d = 12$$

$$d = \frac{1}{3}$$

PTS: 2 REF: 061310a2 STA: A2.A.5 TOP: Inverse Variation

194 ANS: 1

$$\frac{{}_6P_6}{3!2!} = \frac{720}{12} = 60$$

PTS: 2 REF: 011324a2 STA: A2.S.10 TOP: Permutations

195 ANS: 4

$$\frac{3 \pm \sqrt{(-3)^2 - 4(1)(-9)}}{2(1)} = \frac{3 \pm \sqrt{45}}{2} = \frac{3 \pm 3\sqrt{5}}{2}$$

PTS: 2 REF: 061009a2 STA: A2.A.25 TOP: Quadratic Formula

196 ANS: 4 PTS: 2 REF: 061026a2 STA: A2.A.29

TOP: Sequences

197 ANS: 2

$$\frac{-\frac{3}{32}a^3b^4}{\frac{1}{64}a^5b^3} = -\frac{6b}{a^2}$$

PTS: 2 REF: 061326a2 STA: A2.A.31 TOP: Sequences

198 ANS: 3

Cofunctions tangent and cotangent are complementary

PTS: 2 REF: 061014a2 STA: A2.A.58 TOP: Cofunction Trigonometric Relationships

199 ANS: 3

PTS: 2

REF: 061219a2

STA: A2.N.8

TOP: Conjugates of Complex Numbers

200 ANS: 1

If $\sin x = 0.8$, then $\cos x = 0.6$. $\tan \frac{1}{2}x = \sqrt{\frac{1-0.6}{1+0.6}} = \sqrt{\frac{0.4}{1.6}} = 0.5$.

PTS: 2 REF: 061220a2 STA: A2.A.77 TOP: Half Angle Identities

201 ANS: 1

$$4a + 6 = 4a - 10. \quad 4a + 6 = -4a + 10. \quad \left| 4\left(\frac{1}{2}\right) + 6 \right| - 4\left(\frac{1}{2}\right) = -10$$

$$6 \neq -10 \quad 8a = 4 \quad 8 - 2 \neq -10$$

$$a = \frac{4}{8} = \frac{1}{2}$$

PTS: 2 REF: 011106a2 STA: A2.A.1 TOP: Absolute Value Equations

202 ANS: 1

(4) shows the strongest linear relationship, but if $r < 0$, $b < 0$. The Regents announced that a correct solution was not provided for this question and all students should be awarded credit.

PTS: 2 REF: 011223a2 STA: A2.S.8 TOP: Correlation Coefficient

203 ANS: 2

$$f(10) = \frac{-10}{(-10)^2 - 16} = \frac{-10}{84} = -\frac{5}{42}$$

PTS: 2 REF: 061102a2 STA: A2.A.41 TOP: Functional Notation

204 ANS: 4

$$(x+i)^2 - (x-i)^2 = x^2 + 2xi + i^2 - (x^2 - 2xi + i^2) = 4xi$$

PTS: 2 REF: 011327a2 STA: A2.N.9

TOP: Multiplication and Division of Complex Numbers

205 ANS: 3

PTS: 2

REF: 061114a2

STA: A2.A.38

TOP: Defining Functions

KEY: graphs

206 ANS: 3

$$\frac{\sin^2 \theta + \cos^2 \theta}{1 - \sin^2 \theta} = \frac{1}{\cos^2 \theta} = \sec^2 \theta$$

PTS: 2 REF: 061123a2 STA: A2.A.58

TOP: Reciprocal Trigonometric Relationships

207 ANS: 1

n	3	4	5	Σ
$-r^2 + r$	$-3^2 + 3 = -6$	$-4^2 + 4 = -12$	$-5^2 + 5 = -20$	-38

PTS: 2 REF: 061118a2 STA: A2.N.10

TOP: Sigma Notation

KEY: basic

208 ANS: 3

$$s = \theta r = \frac{2\pi}{8} \cdot 6 = \frac{3\pi}{2}$$

PTS: 2 REF: 061212a2 STA: A2.A.61

TOP: Arc Length

KEY: arc length

209 ANS: 3

$$(3i)(2i)^2(m+i)$$

$$(3i)(4i^2)(m+i)$$

$$(3i)(-4)(m+i)$$

$$(-12i)(m+i)$$

$$-12mi - 12i^2$$

$$-12mi + 12$$

PTS: 2 REF: 061319a2 STA: A2.N.9

TOP: Multiplication and Division of Complex Numbers

210 ANS: 1

$$2 \log x - (3 \log y + \log z) = \log x^2 - \log y^3 - \log z = \log \frac{x^2}{y^3 z}$$

PTS: 2 REF: 061010a2 STA: A2.A.19

TOP: Properties of Logarithms

211 ANS: 3

$$\frac{4x-5}{3} > 1 \text{ or } \frac{4x-5}{3} < -1$$

$$4x-5 > 3 \quad 4x-5 < -3$$

$$4x > 8 \quad 4x < 2$$

$$x > 2 \quad x < \frac{1}{2}$$

PTS: 2 REF: 061209a2 STA: A2.A.1

TOP: Absolute Value Inequalities

KEY: graph

212 ANS: 1 PTS: 2 REF: 011306a2 STA: A2.A.8
 TOP: Negative and Fractional Exponents

213 ANS: 2 PTS: 2 REF: 011114a2 STA: A2.N.3
 TOP: Operations with Polynomials

214 ANS: 2
 $6(x^2 - 5) = 6x^2 - 30$

PTS: 2 REF: 011109a2 STA: A2.A.42 TOP: Compositions of Functions
 KEY: variables

215 ANS: 4
 $(3 + \sqrt{5})(3 - \sqrt{5}) = 9 - \sqrt{25} = 4$

PTS: 2 REF: 081001a2 STA: A2.N.4 TOP: Operations with Irrational Expressions
 KEY: without variables | index = 2

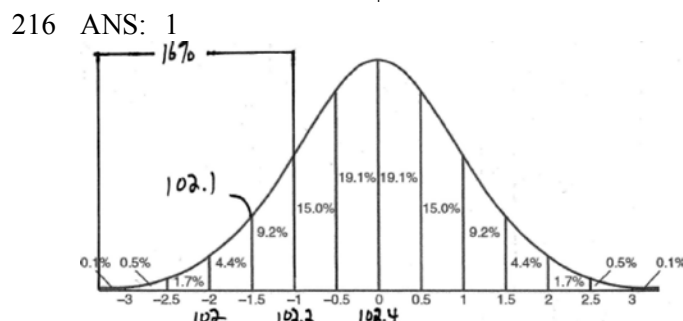

PTS: 2 REF: fall0915a2 STA: A2.S.5 TOP: Normal Distributions
 KEY: interval

217 ANS: 1
 $y \geq x^2 - x - 6$
 $y \geq (x - 3)(x + 2)$

PTS: 2 REF: 061017a2 STA: A2.A.4 TOP: Quadratic Inequalities
 KEY: two variables

218 ANS: 4

```

Plot1 Plot2 Plot3
Y1=2cos(X)-1
Y2=0
Y3=
Y4=
Y5=
Y6=
Y7=
                    
```

```

WINDOW
Xmin=0
Xmax=360
Xsc1=30
Ymin=-5
Ymax=5
Ysc1=1
Xres=1
                    
```

$2 \cos \theta = 1$
 $\cos \theta = \frac{1}{2}$
 $\theta = \cos^{-1} \frac{1}{2} = 60, 300$

PTS: 2 REF: 061203a2 STA: A2.A.68 TOP: Trigonometric Equations
 KEY: basic

219 ANS: 2

$$8^2 = 64$$

PTS: 2 REF: fall0909a2 STA: A2.A.18 TOP: Evaluating Logarithmic Expressions

220 ANS: 1

$$\frac{6}{\sin 35} = \frac{10}{\sin N}$$

$$N \approx 73$$

$$73 + 35 < 180$$

$$(180 - 73) + 35 < 180$$

PTS: 2 REF: 061226a2 STA: A2.A.75 TOP: Law of Sines - The Ambiguous Case

221 ANS: 1 PTS: 2 REF: 061013a2 STA: A2.A.38

TOP: Defining Functions

222 ANS: 4

$$s = \theta r = 2 \cdot 4 = 8$$

PTS: 2 REF: fall0922a2 STA: A2.A.61 TOP: Arc Length

KEY: arc length

223 ANS: 3

sum of the roots, $\frac{-b}{a} = \frac{-(-9)}{4} = \frac{9}{4}$. product of the roots, $\frac{c}{a} = \frac{3}{4}$

PTS: 2 REF: 061208a2 STA: A2.A.21 TOP: Roots of Quadratics

KEY: basic

224 ANS: 1 PTS: 2 REF: 061223a2 STA: A2.S.15

TOP: Binomial Probability KEY: modeling

225 ANS: 2

$$\frac{1 - \frac{4}{x}}{1 - \frac{2}{x} - \frac{8}{x^2}} \times \frac{x^2}{x^2} = \frac{x^2 - 4x}{x^2 - 2x - 8} = \frac{x(x-4)}{(x-4)(x+2)} = \frac{x}{x+2}$$

PTS: 2 REF: 061305a2 STA: A2.A.17 TOP: Complex Fractions

226 ANS: 4 PTS: 2 REF: 081005a2 STA: A2.A.60

TOP: Unit Circle

227 ANS: 3 PTS: 2 REF: fall0910a2 STA: A2.A.76

TOP: Angle Sum and Difference Identities KEY: simplifying

228 ANS: 3

$$3x + 16 = (x + 2)^2 \quad . \quad -4 \text{ is an extraneous solution.}$$

$$3x + 16 = x^2 + 4x + 4$$

$$0 = x^2 + x - 12$$

$$0 = (x + 4)(x - 3)$$

$$x = -4 \quad x = 3$$

PTS: 2 REF: 061121a2 STA: A2.A.22 TOP: Solving Radicals

KEY: extraneous solutions

229 ANS: 3 PTS: 2 REF: 011110a2 STA: A2.A.30

TOP: Sequences

230 ANS: 1 PTS: 2 REF: 011117a2 STA: A2.S.9

TOP: Differentiating Permutations and Combinations

231 ANS: 4 PTS: 2 REF: 011323a2 STA: A2.A.2

TOP: Using the Discriminant KEY: determine nature of roots given equation

232 ANS: 4

Students entering the library are more likely to spend more time studying, creating bias.

PTS: 2 REF: fall0904a2 STA: A2.S.2 TOP: Analysis of Data

233 ANS: 1

L1	L2	L3	3
20	125		
30	125		
40	125		
50	115		
L3(1)=			

LinReg
y=ax+b
a=-.6642857143
b=148.5357143
r ² =.9982686981
r=-.999133974

PTS: 2 REF: 061225a2 STA: A2.S.8 TOP: Correlation Coefficient

234 ANS: 2 PTS: 2 REF: fall0926a2 STA: A2.A.46

TOP: Transformations with Functions and Relations

235 ANS: 4

$$2 \log_4(5x) = 3$$

$$\log_4(5x) = \frac{3}{2}$$

$$5x = 4^{\frac{3}{2}}$$

$$5x = 8$$

$$x = \frac{8}{5}$$

PTS: 2 REF: fall0921a2 STA: A2.A.28 TOP: Logarithmic Equations

KEY: advanced

236 ANS: 2

$$320 = 10(2)^{\frac{t}{60}}$$

$$32 = (2)^{\frac{t}{60}}$$

$$\log 32 = \log(2)^{\frac{t}{60}}$$

$$\log 32 = \frac{t \log 2}{60}$$

$$\frac{60 \log 32}{\log 2} = t$$

$$300 = t$$

PTS: 2 REF: 011205a2 STA: A2.A.6 TOP: Exponential Growth

237 ANS: 4 PTS: 2 REF: 061303a2 STA: A2.A.43

TOP: Defining Functions

238 ANS: 3

$$\frac{-b}{a} = \frac{-6}{2} = -3. \quad \frac{c}{a} = \frac{4}{2} = 2$$

PTS: 2 REF: 011121a2 STA: A2.A.21 TOP: Roots of Quadratics

KEY: basic

239 ANS: 4

$$\frac{4 \cdot 0 + 6 \cdot 1 + 10 \cdot 2 + 0 \cdot 3 + 4k + 2 \cdot 5}{4 + 6 + 10 + 0 + k + 2} = 2$$

$$\frac{4k + 36}{k + 22} = 2$$

$$4k + 36 = 2k + 44$$

$$2k = 8$$

$$k = 4$$

PTS: 2 REF: 061221a2 STA: A2.S.3 TOP: Average Known with Missing Data

240 ANS: 4

$$\frac{x}{x - \sqrt{x}} \times \frac{x + \sqrt{x}}{x + \sqrt{x}} = \frac{x^2 + x\sqrt{x}}{x^2 - x} = \frac{x(x + \sqrt{x})}{x(x - 1)} = \frac{x + \sqrt{x}}{x - 1}$$

PTS: 2 REF: 061325a2 STA: A2.A.15 TOP: Rationalizing Denominators

KEY: index = 2

241 ANS: 1

$$\sin(180 + x) = (\sin 180)(\cos x) + (\cos 180)(\sin x) = 0 + (-\sin x) = -\sin x$$

PTS: 2 REF: 011318a2 STA: A2.A.76 TOP: Angle Sum and Difference Identities

KEY: identities

242 ANS: 1 PTS: 2 REF: fall0914a2 STA: A2.A.9
TOP: Negative and Fractional Exponents

243 ANS: 3
 ${}_3C_2(2x^4)^1(-y)^2 = 6x^4y^2$

PTS: 2 REF: 011215a2 STA: A2.A.36 TOP: Binomial Expansions

Algebra 2/Trigonometry 2 Point Regents Exam Questions Answer Section

244 ANS:

$$\frac{12x^2}{y^9} \cdot \frac{3x^{-4}y^5}{(2x^3y^{-7})^{-2}} = \frac{3y^5(2x^3y^{-7})^2}{x^4} = \frac{3y^5(4x^6y^{-14})}{x^4} = \frac{12x^6y^{-9}}{x^4} = \frac{12x^2}{y^9}$$

PTS: 2 REF: 061134a2 STA: A2.A.9 TOP: Negative Exponents

245 ANS:

$$\text{Sum } \frac{-b}{a} = -\frac{11}{5}. \text{ Product } \frac{c}{a} = -\frac{3}{5}$$

PTS: 2 REF: 061030a2 STA: A2.A.20 TOP: Roots of Quadratics

246 ANS:

$y = -3 \sin 2x$. The period of the function is π , the amplitude is 3 and it is reflected over the x -axis.

PTS: 2 REF: 061235a2 STA: A2.A.72

TOP: Identifying the Equation of a Trigonometric Graph

247 ANS:

$$\frac{\frac{1}{2} - \frac{4}{d}}{\frac{1}{d} + \frac{3}{2d}} = \frac{\frac{d-8}{2d}}{\frac{2d+3d}{2d^2}} = \frac{d-8}{2d} \times \frac{2d^2}{5d} = \frac{d-8}{5}$$

PTS: 2 REF: 061035a2 STA: A2.A.17 TOP: Complex Fractions

248 ANS:

$$e^{3 \ln 2} = e^{\ln 2^3} = e^{\ln 8} = 8$$

PTS: 2 REF: 061131a2 STA: A2.A.12 TOP: Evaluating Exponential Expressions

249 ANS:

$$230. 10 + (1^3 - 1) + (2^3 - 1) + (3^3 - 1) + (4^3 - 1) + (5^3 - 1) = 10 + 0 + 7 + 26 + 63 + 124 = 230$$

PTS: 2 REF: 011131a2 STA: A2.N.10 TOP: Sigma Notation

KEY: basic

250 ANS:

$$\frac{\sqrt{3}}{2} \times \frac{\sqrt{2}}{2} = \frac{\sqrt{6}}{4}$$

PTS: 2 REF: 061331a2 STA: A2.A.56 TOP: Determining Trigonometric Functions

KEY: degrees, common angles

251 ANS:

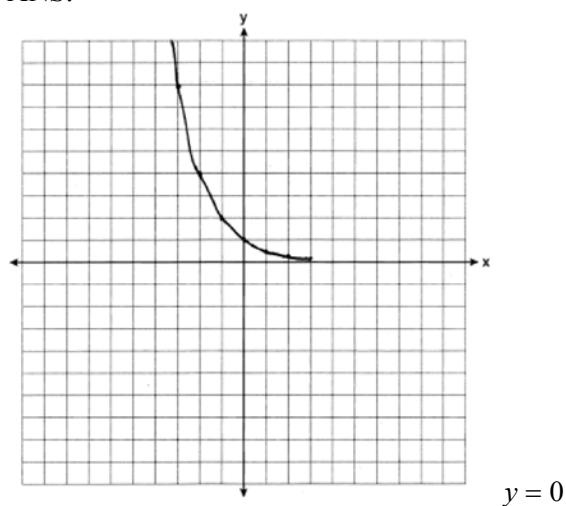

PTS: 2 REF: 061031a2 STA: A2.A.53 TOP: Graphing Exponential Functions

252 ANS:
7.4

PTS: 2 REF: 061029a2 STA: A2.S.4 TOP: Dispersion
KEY: basic, group frequency distributions

253 ANS:

$$y = 180.377(0.954)^x$$

PTS: 2 REF: 061231a2 STA: A2.S.7 TOP: Exponential Regression

254 ANS:

$$i^{13} + i^{18} + i^{31} + n = 0$$

$$i + (-1) - i + n = 0$$

$$-1 + n = 0$$

$$n = 1$$

PTS: 2 REF: 061228a2 STA: A2.N.7 TOP: Imaginary Numbers

255 ANS:

$$3 - 2x \geq 7 \quad \text{or} \quad 3 - 2x \leq -7$$

$$-2x \geq 4 \quad -2x \leq -10$$

$$x \leq -2 \quad x \geq 5$$

PTS: 2 REF: 011334a2 STA: A2.A.1 TOP: Absolute Value Inequalities
KEY: graph

256 ANS:

$$A = 750e^{(0.03)(8)} \approx 953$$

PTS: 2 REF: 061229a2 STA: A2.A.12 TOP: Evaluating Exponential Expressions

257 ANS:

$$\sum_{n=1}^{15} 7n$$

PTS: 2 REF: 081029a2 STA: A2.A.34 TOP: Sigma Notation

258 ANS:

no solution. $\frac{4x}{x-3} = 2 + \frac{12}{x-3}$

$$\frac{4x-12}{x-3} = 2$$

$$\frac{4(x-3)}{x-3} = 2$$

$$4 \neq 2$$

PTS: 2 REF: fall0930a2 STA: A2.A.23 TOP: Solving Rationals

KEY: rational solutions

259 ANS:

$$30700 = 50e^{3t}$$

$$614 = e^{3t}$$

$$\ln 614 = \ln e^{3t}$$

$$\ln 614 = 3t \ln e$$

$$\ln 614 = 3t$$

$$2.14 \approx t$$

PTS: 2 REF: 011333a2 STA: A2.A.6 TOP: Exponential Growth

260 ANS:

$$b^2 - 4ac = 0$$

$$k^2 - 4(1)(4) = 0$$

$$k^2 - 16 = 0$$

$$(k+4)(k-4) = 0$$

$$k = \pm 4$$

PTS: 2 REF: 061028a2 STA: A2.A.2 TOP: Using the Discriminant

KEY: determine equation given nature of roots

261 ANS:

$${}^7C_3 \left(\frac{1}{4}\right)^3 \left(\frac{3}{4}\right)^4 = 35 \left(\frac{1}{64}\right) \left(\frac{81}{256}\right) = \frac{2835}{16384} \approx 0.173$$

PTS: 2 REF: 061335a2 STA: A2.S.15 TOP: Binomial Probability

KEY: exactly

262 ANS:

$$\text{Sum } \frac{-b}{a} = -\frac{1}{12}. \text{ Product } \frac{c}{a} = -\frac{1}{2}$$

PTS: 2 REF: 061328a2 STA: A2.A.20 TOP: Roots of Quadratics

263 ANS:

$$\frac{4}{9}x^2 - \frac{4}{3}x + 1. \left(\frac{2}{3}x - 1\right)^2 = \left(\frac{2}{3}x - 1\right)\left(\frac{2}{3}x - 1\right) = \frac{4}{9}x^2 - \frac{2}{3}x - \frac{2}{3}x + 1 = \frac{4}{9}x^2 - \frac{4}{3}x + 1$$

PTS: 2 REF: 081034a2 STA: A2.N.3 TOP: Operations with Polynomials

264 ANS:

$$7. f(-3) = (-3)^2 - 6 = 3. g(x) = 2^3 - 1 = 7.$$

PTS: 2 REF: 061135a2 STA: A2.A.42 TOP: Compositions of Functions
KEY: numbers

265 ANS:

$$K = ab\sin C = 24 \cdot 30 \sin 57 \approx 604$$

PTS: 2 REF: 061034a2 STA: A2.A.74 TOP: Using Trigonometry to Find Area
KEY: parallelograms

266 ANS:

$$12t^8 - 75t^4 = 3t^4(4t^4 - 25) = 3t^4(2t^2 + 5)(2t^2 - 5)$$

PTS: 2 REF: 061133a2 STA: A2.A.7 TOP: Factoring the Difference of Perfect Squares
KEY: binomial

267 ANS:

$$\frac{a^2b^3}{4}$$

PTS: 2 REF: 011231a2 STA: A2.A.13 TOP: Simplifying Radicals
KEY: index > 2

268 ANS:

$$a_1 = 3. a_2 = 2(3) - 1 = 5. a_3 = 2(5) - 1 = 9.$$

PTS: 2 REF: 061233a2 STA: A2.A.33 TOP: Recursive Sequences

269 ANS:

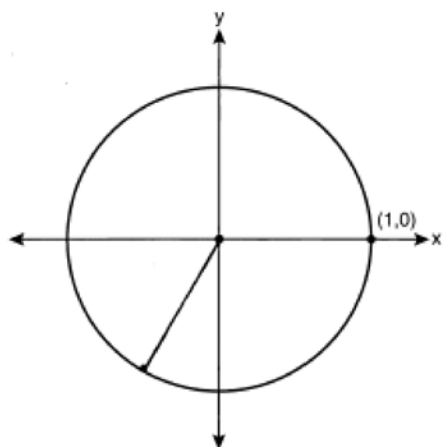

$$-\frac{\sqrt{3}}{2}$$

PTS: 2

REF: 061033a2

STA: A2.A.60

TOP: Unit Circle

270 ANS:

$$2x - 1 = 27^{\frac{4}{3}}$$

$$2x - 1 = 81$$

$$2x = 82$$

$$x = 41$$

PTS: 2

REF: 061329a2

STA: A2.A.28

TOP: Logarithmic Equations

KEY: advanced

271 ANS:

$$\frac{\sqrt{108x^5y^8}}{\sqrt{6xy^5}} = \sqrt{18x^4y^3} = 3x^2y\sqrt{2y}$$

PTS: 2

REF: 011133a2

STA: A2.A.14

TOP: Operations with Radicals

KEY: with variables | index = 2

272 ANS:

$$5\sqrt{3x^3} - 2\sqrt{27x^3} = 5\sqrt{x^2}\sqrt{3x} - 2\sqrt{9x^2}\sqrt{3x} = 5x\sqrt{3x} - 6x\sqrt{3x} = -x\sqrt{3x}$$

PTS: 2

REF: 061032a2

STA: A2.N.2

TOP: Operations with Radicals

273 ANS:

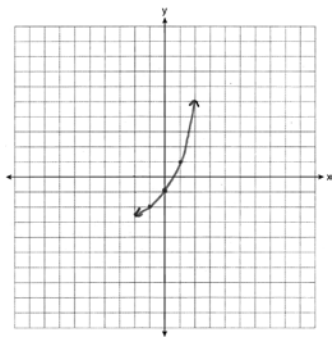

PTS: 2

REF: 011234a2

STA: A2.A.53

TOP: Graphing Exponential Functions

274 ANS:

$$\left(3 \times \frac{180}{\pi}\right) \rightarrow \text{DMS}$$

$$171^\circ 53' 14.419''$$

$$3 \times \frac{180}{\pi} \approx 171.89^\circ \approx 171^\circ 53'$$

PTS: 2

REF: 011335a2

STA: A2.M.2

TOP: Radian Measure

KEY: degrees

275 ANS:

$$\cos \theta \cdot \frac{1}{\cos \theta} - \cos^2 \theta = 1 - \cos^2 \theta = \sin^2 \theta$$

PTS: 2

REF: 061230a2

STA: A2.A.58

TOP: Reciprocal Trigonometric Relationships

276 ANS:

-3, -5, -8, -12

PTS: 2

REF: fall0934a2

STA: A2.A.33

TOP: Recursive Sequences

277 ANS:

$$(x + 5)^2 + (y - 3)^2 = 32$$

PTS: 2

REF: 081033a2

STA: A2.A.49

TOP: Writing Equations of Circles

278 ANS:

Controlled experiment because Howard is comparing the results obtained from an experimental sample against a control sample.

PTS: 2

REF: 081030a2

STA: A2.S.1

TOP: Analysis of Data

279 ANS:

Ordered, the heights are 71, 71, 72, 74, 74, 75, 78, 79, 79, 83. $Q_1 = 72$ and $Q_3 = 79$. $79 - 72 = 7$.

PTS: 2

REF: 011331a2

STA: A2.S.4

TOP: Dispersion

KEY: range, quartiles, interquartile range, variance

280 ANS:

$$\frac{\cot x \sin x}{\sec x} = \frac{\frac{\cos x}{\sin x} \sin x}{\frac{1}{\cos x}} = \cos^2 x$$

PTS: 2 REF: 061334a2 STA: A2.A.58 TOP: Reciprocal Trigonometric Relationships

281 ANS:

$$16^{2x+3} = 64^{x+2}$$

$$(4^2)^{2x+3} = (4^3)^{x+2}$$

$$4x + 6 = 3x + 6$$

$$x = 0$$

PTS: 2 REF: 011128a2 STA: A2.A.27 TOP: Exponential Equations

KEY: common base not shown

282 ANS:

$$6y^3 - \frac{37}{10}y^2 - \frac{1}{5}y \cdot \left(\frac{1}{2}y^2 - \frac{1}{3}y \right) \left(12y + \frac{3}{5} \right) = 6y^3 + \frac{3}{10}y^2 - 4y^2 - \frac{1}{5}y = 6y^3 - \frac{37}{10}y^2 - \frac{1}{5}y$$

PTS: 2 REF: 061128a2 STA: A2.N.3 TOP: Operations with Polynomials

283 ANS:

$$\frac{\sin^2 A}{\cos^2 A} + \frac{\cos^2 A}{\cos^2 A} = \frac{1}{\cos^2 A}$$

$$\tan^2 A + 1 = \sec^2 A$$

PTS: 2 REF: 011135a2 STA: A2.A.67 TOP: Proving Trigonometric Identities

284 ANS:

$$r = \sqrt{2^2 + 3^2} = \sqrt{13}. (x+5)^2 + (y-2)^2 = 13$$

PTS: 2 REF: 011234a2 STA: A2.A.49 TOP: Writing Equations of Circles

285 ANS:

$$10ax^2 - 23ax - 5a = a(10x^2 - 23x - 5) = a(5x+1)(2x-5)$$

PTS: 2 REF: 081028a2 STA: A2.A.7 TOP: Factoring Polynomials

KEY: multiple variables

286 ANS:

$$197^\circ 40'. \quad 3.45 \times \frac{180}{\pi} \approx 197^\circ 40'.$$

3.45*180/pi
197.6704393
Ans to DMS
197°40'13.582"

PTS: 2

REF: fall0931a2

STA: A2.M.2

TOP: Radian Measure

KEY: degrees

287 ANS:

2,298.65.

1200e^(.065*10)
2298.648995

PTS: 2

REF: fall0932a2

STA: A2.A.12

TOP: Evaluating Exponential Expressions

288 ANS:

$$\frac{5(3 + \sqrt{2})}{7} \cdot \frac{5}{3 - \sqrt{2}} \times \frac{3 + \sqrt{2}}{3 + \sqrt{2}} = \frac{5(3 + \sqrt{2})}{9 - 2} = \frac{5(3 + \sqrt{2})}{7}$$

PTS: 2

REF: fall0928a2

STA: A2.N.5

TOP: Rationalizing Denominators

289 ANS:

$$K = ab \sin C = 18 \cdot 22 \sin 60 = 396 \frac{\sqrt{3}}{2} = 198\sqrt{3}$$

PTS: 2

REF: 061234a2

STA: A2.A.74

TOP: Using Trigonometry to Find Area

KEY: Parallelograms

290 ANS:

68% of the students are within one standard deviation of the mean. 16% of the students are more than one standard deviation above the mean.

PTS: 2

REF: 011134a2

STA: A2.S.5

TOP: Normal Distributions

KEY: percent

291 ANS:

$$12 \cdot 6 = 9w$$

$$8 = w$$

PTS: 2

REF: 011130a2

STA: A2.A.5

TOP: Inverse Variation

292 ANS:

no. over 20 is more than 1 standard deviation above the mean. $0.159 \cdot 82 \approx 13.038$

PTS: 2

REF: 061129a2

STA: A2.S.5

TOP: Normal Distributions

KEY: predict

293 ANS:

$$a_n = 9n - 4 \quad \therefore S_n = \frac{20(5 + 176)}{2} = 1810$$

$$a_1 = 9(1) - 4 = 5$$

$$a_{20} = 9(20) - 4 = 176$$

PTS: 2 REF: 011328a2 STA: A2.A.35 TOP: Summations

KEY: arithmetic

294 ANS:



$$\sum_{k=1}^{10} (-x^k - x) = -104$$

PTS: 2 REF: 011230a2 STA: A2.N.10 TOP: Sigma Notation

KEY: basic

295 ANS:

$$(x + 3)^2 + (y - 4)^2 = 25$$

PTS: 2 REF: fall0929a2 STA: A2.A.49 TOP: Writing Equations of Circles

296 ANS:

$$x^2 - 6x - 27 = 0, \quad \frac{-b}{a} = 6, \quad \frac{c}{a} = -27. \quad \text{If } a = 1 \text{ then } b = -6 \text{ and } c = -27$$

PTS: 4 REF: 061130a2 STA: A2.A.21 TOP: Roots of Quadratics

KEY: basic

297 ANS:

$$\frac{2\sqrt{3}}{3}. \quad \text{If } \sin 60 = \frac{\sqrt{3}}{2}, \text{ then } \csc 60 = \frac{2}{\sqrt{3}} \cdot \frac{\sqrt{3}}{\sqrt{3}} = \frac{2\sqrt{3}}{3}$$

PTS: 2 REF: 011235a2 STA: A2.A.59 TOP: Reciprocal Trigonometric Relationships

298 ANS:

$$39,916,800. \quad \frac{{}_{12}P_{12}}{3! \cdot 2!} = \frac{479,001,600}{12} = 39,916,800$$

PTS: 2 REF: 081035a2 STA: A2.S.10 TOP: Permutations

299 ANS:

$${}_{25}C_{20} = 53,130$$

PTS: 2 REF: 011232a2 STA: A2.S.11 TOP: Combinations

300 ANS:

$$y = x^2 - 6. \quad f^{-1}(x) \text{ is not a function.}$$

$$x = y^2 - 6$$

$$x + 6 = y^2$$

$$\pm\sqrt{x+6} = y$$

PTS: 2 REF: 061132a2 STA: A2.A.44 TOP: Inverse of Functions
KEY: equations

301 ANS:

$$y = 10.596(1.586)^x$$

PTS: 2 REF: 081031a2 STA: A2.S.7 TOP: Exponential Regression

302 ANS:

$$D: -5 \leq x \leq 8. \quad R: -3 \leq y \leq 2$$

PTS: 2 REF: 011132a2 STA: A2.A.51 TOP: Domain and Range

303 ANS:

$$\frac{2 \pm \sqrt{(-2)^2 - 4(6)(-3)}}{2(6)} = \frac{2 \pm \sqrt{76}}{12} = \frac{2 \pm \sqrt{4} \sqrt{19}}{12} = \frac{2 \pm 2\sqrt{19}}{12} = \frac{1 \pm \sqrt{19}}{6}$$

PTS: 2 REF: 011332a2 STA: A2.A.25 TOP: Quadratics with Irrational Solutions

304 ANS:

$$216 \left(\frac{\pi}{180} \right) \approx 3.8$$

PTS: 2 REF: 061232a2 STA: A2.M.2 TOP: Radian Measure
KEY: radians

305 ANS:



41,040.

PTS: 2 REF: fall0935a2 STA: A2.S.12 TOP: Sample Space

306 ANS:

$$g(10) = \left(a(10)\sqrt{1-x} \right)^2 = 100a^2(-9) = -900a^2$$

PTS: 2 REF: 061333a2 STA: A2.A.41 TOP: Functional Notation

307 ANS:

$$2.5 \cdot \frac{180}{\pi} \approx 143.2^\circ$$

PTS: 2 REF: 011129a2 STA: A2.M.2 TOP: Radian Measure
KEY: degrees

308 ANS:

$$\frac{{}_{10}P_{10}}{3! \cdot 3! \cdot 2!} = \frac{3,628,800}{72} = 50,400$$

PTS: 2 REF: 061330a2 STA: A2.S.10 TOP: Permutations

309 ANS:

$$\frac{\sqrt{13}}{2} \cdot \sin \theta = \frac{y}{\sqrt{x^2 + y^2}} = \frac{2}{\sqrt{(-3)^2 + 2^2}} = \frac{2}{\sqrt{13}} \cdot \csc \theta = \frac{\sqrt{13}}{2}$$

PTS: 2 REF: fall0933a2 STA: A2.A.62 TOP: Determining Trigonometric Functions

310 ANS:

$$5 \csc \theta = 8$$

$$\csc \theta = \frac{8}{5}$$

$$\sin \theta = \frac{5}{8}$$

$$\theta \approx 141$$

PTS: 2 REF: 061332a2 STA: A2.A.68 TOP: Trigonometric Equations
KEY: reciprocal functions

311 ANS:

$$45,225 \quad 2 \tan C - 3 = 3 \tan C - 4$$

$$1 = \tan C$$

$$\tan^{-1} 1 = C$$

$$C = 45, 225$$

PTS: 2 REF: 081032a2 STA: A2.A.68 TOP: Trigonometric Equations
KEY: basic

312 ANS:

$$x < -1 \text{ or } x > 5. \quad x^2 - 4x - 5 > 0. \quad x - 5 > 0 \text{ and } x + 1 > 0 \text{ or } x - 5 < 0 \text{ and } x + 1 < 0$$

$$(x - 5)(x + 1) > 0 \quad x > 5 \text{ and } x > -1 \quad x < 5 \text{ and } x < -1$$

$$x > 5$$

$$x < -1$$

PTS: 2 REF: 011228a2 STA: A2.A.4 TOP: Quadratic Inequalities
KEY: one variable

313 ANS:

$$\begin{aligned}
 7. \quad & 4 - \sqrt{2x-5} = 1 \\
 & -\sqrt{2x-5} = -3 \\
 & 2x - 5 = 9 \\
 & 2x = 14 \\
 & x = 7
 \end{aligned}$$

PTS: 2

REF: 011229a2

STA: A2.A.22

TOP: Solving Radicals

KEY: basic

314 ANS:

$$\begin{aligned}
 a + 15 + 2a &= 90 \\
 3a + 15 &= 90 \\
 3a &= 75 \\
 a &= 25
 \end{aligned}$$

PTS: 2

REF: 011330a2

STA: A2.A.58

TOP: Cofunction Trigonometric Relationships

315 ANS:

$$3x^2 - 11x + 6 = 0. \text{ Sum } \frac{-b}{a} = \frac{11}{3}. \text{ Product } \frac{c}{a} = \frac{6}{3} = 2$$

PTS: 2

REF: 011329a2

STA: A2.A.20

TOP: Roots of Quadratics

Algebra 2/Trigonometry 4 Point Regents Exam Questions Answer Section

316 ANS:

$$\frac{1}{3} \cdot \frac{1}{x+3} - \frac{2}{3-x} = \frac{4}{x^2-9}$$

$$\frac{1}{x+3} + \frac{2}{x-3} = \frac{4}{x^2-9}$$

$$\frac{x-3+2(x+3)}{(x+3)(x-3)} = \frac{4}{(x+3)(x-3)}$$

$$x-3+2x+6=4$$

$$3x=1$$

$$x = \frac{1}{3}$$

PTS: 4 REF: 081036a2 STA: A2.A.23 TOP: Solving Rationals

KEY: rational solutions

317 ANS:

$$32x^5 - 80x^4 + 80x^3 - 40x^2 + 10x - 1. \quad {}_5C_0(2x)^5(-1)^0 = 32x^5. \quad {}_5C_1(2x)^4(-1)^1 = -80x^4. \quad {}_5C_2(2x)^3(-1)^2 = 80x^3. \\ {}_5C_3(2x)^2(-1)^3 = -40x^2. \quad {}_5C_4(2x)^1(-1)^4 = 10x. \quad {}_5C_5(2x)^0(-1)^5 = -1$$

PTS: 4 REF: 011136a2 STA: A2.A.36 TOP: Binomial Expansions

318 ANS:

$$y = 215.983(1.652)^x. \quad 215.983(1.652)^7 \approx 7250$$

PTS: 4 REF: 011337a2 STA: A2.S.7 TOP: Exponential Regression

319 ANS:

$$\frac{15}{\sin 103} = \frac{a}{\sin 42} \cdot \frac{1}{2} (15)(10.3)\sin 35 \approx 44$$

$$a \approx 10.3$$

PTS: 4 REF: 061337a2 STA: A2.A.74 TOP: Using Trigonometry to Find Area

KEY: advanced

320 ANS:

$$\frac{100}{\sin 32} = \frac{b}{\sin 105} \cdot \frac{100}{\sin 32} = \frac{a}{\sin 43}$$

$$b \approx 182.3$$

$$a \approx 128.7$$

PTS: 4 REF: 011338a2 STA: A2.A.73 TOP: Law of Sines

KEY: basic

321 ANS:

$$-3|6-x| < -15$$

$$|6-x| > 5$$

$$6-x > 5 \text{ or } 6-x < -5$$

$$1 > x \text{ or } 11 < x$$

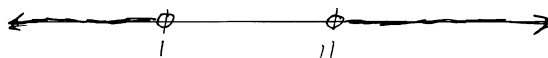

PTS: 2

REF: 061137a2

STA: A2.A.1

TOP: Absolute Value Inequalities

KEY: graph

322 ANS:

$$\frac{51}{243} \cdot {}_5C_3 \left(\frac{1}{3}\right)^3 \left(\frac{2}{3}\right)^2 = \frac{40}{243}$$

$${}_5C_4 \left(\frac{1}{3}\right)^4 \left(\frac{2}{3}\right)^1 = \frac{10}{243}$$

$${}_5C_3 \left(\frac{1}{3}\right)^5 \left(\frac{2}{3}\right)^0 = \frac{1}{243}$$

PTS: 4

REF: 061138a2

STA: A2.S.15

TOP: Binomial Probability

KEY: at least or at most

323 ANS:

$$88. \frac{100}{\sin 33} = \frac{x}{\sin 32} \cdot \sin 66 \approx \frac{T}{97.3}$$

$$x \approx 97.3 \quad t \approx 88$$

PTS: 4

REF: 011236a2

STA: A2.A.73

TOP: Law of Sines

KEY: advanced

324 ANS:

$$\frac{-(x^2-4)}{(x+4)(x+3)} \times \frac{x+3}{2(x-2)} = \frac{-(x+2)(x-2)}{x+4} \times \frac{1}{2(x-2)} = \frac{-(x+2)}{2(x+4)}$$

PTS: 4

REF: 061236a2

STA: A2.A.16

TOP: Multiplication and Division of Rationals

KEY: division

325 ANS:

$$0.468 \cdot {}_8C_6 \left(\frac{2}{3}\right)^6 \left(\frac{1}{3}\right)^2 \approx 0.27313. \quad {}_8C_7 \left(\frac{2}{3}\right)^7 \left(\frac{1}{3}\right)^1 \approx 0.15607. \quad {}_8C_8 \left(\frac{2}{3}\right)^8 \left(\frac{1}{3}\right)^0 \approx 0.03902.$$

PTS: 4

REF: 011138a2

STA: A2.S.15

TOP: Binomial Probability

KEY: at least or at most

326 ANS:

$$\frac{13}{x} = 10 - x \quad \therefore x = \frac{10 \pm \sqrt{100 - 4(1)(13)}}{2(1)} = \frac{10 \pm \sqrt{48}}{2} = \frac{10 \pm 4\sqrt{3}}{2} = 5 \pm 2\sqrt{3}$$

$$13 = 10x - x^2$$

$$x^2 - 10x + 13 = 0$$

PTS: 4 REF: 061336a2 STA: A2.A.23 TOP: Solving Rationals

KEY: irrational and complex solutions

327 ANS:

 $\sigma_x = 14.9$. $\bar{x} = 40$. There are 8 scores between 25.1 and 54.9.

PTS: 4 REF: 061237a2 STA: A2.S.4 TOP: Dispersion

KEY: advanced

328 ANS:

$$26.2\%. {}_{10}C_8 \cdot 0.65^8 \cdot 0.35^2 + {}_{10}C_9 \cdot 0.65^9 \cdot 0.35^1 + {}_{10}C_{10} \cdot 0.65^{10} \cdot 0.35^0 \approx 0.262$$

PTS: 4 REF: 081038a2 STA: A2.S.15 TOP: Binomial Probability

KEY: at least or at most

329 ANS:

$$\pm \frac{3}{2}, -\frac{1}{2}. \quad 8x^3 + 4x^2 - 18x - 9 = 0$$

$$4x^2(2x + 1) - 9(2x + 1) = 0$$

$$(4x^2 - 9)(2x + 1) = 0$$

$$4x^2 - 9 = 0 \text{ or } 2x + 1 = 0$$

$$(2x + 3)(2x - 3) = 0 \quad x = -\frac{1}{2}$$

$$x = \pm \frac{3}{2}$$

PTS: 4 REF: fall0937a2 STA: A2.A.26 TOP: Solving Polynomial Equations

330 ANS:

$$0.167. {}_{10}C_8 \cdot 0.6^8 \cdot 0.4^2 + {}_{10}C_9 \cdot 0.6^9 \cdot 0.4^1 + {}_{10}C_{10} \cdot 0.6^{10} \cdot 0.4^0 \approx 0.167$$

PTS: 4 REF: 061036a2 STA: A2.S.15 TOP: Binomial Probability

KEY: at least or at most

331 ANS:

$$y = 27.2025(1.1509)^x. \quad y = 27.2025(1.1509)^{18} \approx 341$$

PTS: 4 REF: 011238a2 STA: A2.S.7 TOP: Exponential Regression

332 ANS:

$$(x + 4)^2 = 17x - 4$$

$$x^2 + 8x + 16 = 17x - 4$$

$$x^2 - 9x + 20 = 0$$

$$(x - 4)(x - 5) = 0$$

$$x = 4, 5$$

PTS: 4

REF: 011336a2

STA: A2.A.28

TOP: Logarithmic Equations

KEY: basic

333 ANS:

$$3 \pm \sqrt{7}. \quad 2x^2 - 12x + 4 = 0$$

$$x^2 - 6x + 2 = 0$$

$$x^2 - 6x = -2$$

$$x^2 - 6x + 9 = -2 + 9$$

$$(x - 3)^2 = 7$$

$$x - 3 = \pm\sqrt{7}$$

$$x = 3 \pm \sqrt{7}$$

PTS: 4

REF: fall0936a2

STA: A2.A.24

TOP: Completing the Square

334 ANS:

0, 60, 180, 300.

$$\sin 2\theta = \sin \theta$$

$$\sin 2\theta - \sin \theta = 0$$

$$2 \sin \theta \cos \theta - \sin \theta = 0$$

$$\sin \theta (2 \cos \theta - 1) = 0$$

$$\sin \theta = 0 \quad 2 \cos \theta - 1 = 0$$

$$\theta = 0, 180 \quad \cos \theta = \frac{1}{2}$$

$$\theta = 60, 300$$

PTS: 4

REF: 061037a2

STA: A2.A.68

TOP: Trigonometric Equations

KEY: double angle identities

335 ANS:

$$y = 2.001x^{2.298}, 1,009. \quad y = 2.001(15)^{2.298} \approx 1009$$

PTS: 4

REF: fall0938a2

STA: A2.S.7

TOP: Power Regression

336 ANS:

$$800. x = 4^{2.5} = 32. y^{-\frac{3}{2}} = 125 \quad \cdot \quad \frac{x}{y} = \frac{32}{\frac{1}{25}} = 800$$

$$y = 125^{-\frac{2}{3}} = \frac{1}{25}$$

PTS: 4 REF: 011237a2 STA: A2.A.28 TOP: Logarithmic Equations

KEY: advanced

337 ANS:

$$\frac{12}{\sin 32} = \frac{10}{\sin B} \quad \cdot \quad C \approx 180 - (32 + 26.2) \approx 121.8. \quad \frac{12}{\sin 32} = \frac{c}{\sin 121.8}$$

$$B = \sin^{-1} \frac{10 \sin 32}{12} \approx 26.2 \quad c = \frac{12 \sin 121.8}{\sin 32} \approx 19.2$$

PTS: 4 REF: 011137a2 STA: A2.A.73 TOP: Law of Sines

KEY: basic

338 ANS:

$$\sin(45 + 30) = \sin 45 \cos 30 + \cos 45 \sin 30$$

$$= \frac{\sqrt{2}}{2} \cdot \frac{\sqrt{3}}{2} + \frac{\sqrt{2}}{2} \cdot \frac{1}{2} = \frac{\sqrt{6}}{4} + \frac{\sqrt{2}}{4} = \frac{\sqrt{6} + \sqrt{2}}{4}$$

PTS: 4 REF: 061136a2 STA: A2.A.76 TOP: Angle Sum and Difference Identities

KEY: evaluating

339 ANS:

$$\text{No. TENNESSEE: } \frac{{}_9P_9}{4! \cdot 2! \cdot 2!} = \frac{362,880}{96} = 3,780. \quad \text{VERMONT: } {}_7P_7 = 5,040$$

PTS: 4 REF: 061038a2 STA: A2.S.10 TOP: Permutations

340 ANS:

$$\begin{aligned} \frac{23}{2} \quad \cos^2 B + \sin^2 B &= 1 & \tan B &= \frac{\sin B}{\cos B} = \frac{\frac{5}{\sqrt{41}}}{\frac{4}{\sqrt{41}}} = \frac{5}{4} \\ \cos^2 B + \left(\frac{5}{\sqrt{41}} \right)^2 &= 1 \\ \cos^2 B + \frac{25}{41} &= \frac{41}{41} \\ \cos^2 B &= \frac{16}{41} \\ \cos B &= \frac{4}{\sqrt{41}} \\ \tan(A+B) &= \frac{\frac{2}{3} + \frac{5}{4}}{1 - \left(\frac{2}{3} \right) \left(\frac{5}{4} \right)} = \frac{\frac{8+15}{12}}{\frac{12}{12} - \frac{10}{12}} = \frac{\frac{23}{12}}{\frac{2}{12}} = \frac{23}{2} \end{aligned}$$

PTS: 4 REF: 081037a2 STA: A2.A.76 TOP: Angle Sum and Difference Identities
KEY: evaluating

341 ANS:

$\sigma_x \approx 6.2$. 6 scores are within a population standard deviation of the mean. $Q_3 - Q_1 = 41 - 37 = 4$
 $\bar{x} \approx 38.2$

PTS: 4 REF: 061338a2 STA: A2.S.4 TOP: Dispersion
KEY: advanced

342 ANS:

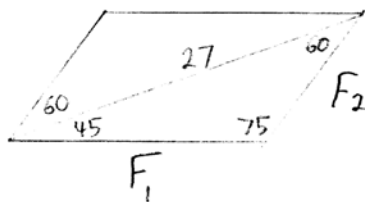

$$\begin{aligned} \frac{27}{\sin 75} &= \frac{F_1}{\sin 60} & \frac{27}{\sin 75} &= \frac{F_2}{\sin 45} \\ F_1 &\approx 24 & F_2 &\approx 20 \end{aligned}$$

PTS: 4 REF: 061238a2 STA: A2.A.73 TOP: Vectors

Algebra 2/Trigonometry 6 Point Regents Exam Questions Answer Section

343 ANS:

$$33. a = \sqrt{10^2 + 6^2 - 2(10)(6)\cos 80} \approx 10.7. \angle C \text{ is opposite the shortest side. } \frac{6}{\sin C} = \frac{10.7}{\sin 80}$$

$$C \approx 33$$

PTS: 6

REF: 061039a2

STA: A2.A.73

TOP: Law of Cosines

KEY: advanced

344 ANS:

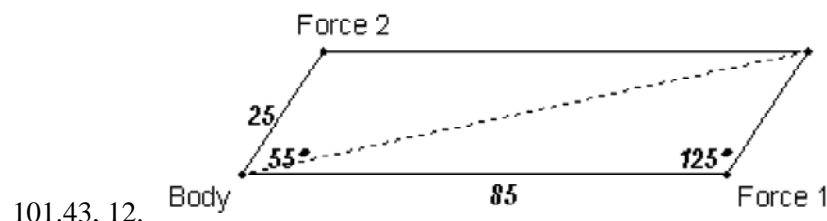

101.43, 12.

$$r^2 = 25^2 + 85^2 - 2(25)(85)\cos 125.$$

$$r^2 \approx 10287.7$$

$$r \approx 101.43$$

$$\frac{2.5}{\sin x} = \frac{101.43}{\sin 125}$$

$$x \approx 12$$

PTS: 6

REF: fall0939a2

STA: A2.A.73

TOP: Vectors

345 ANS:

$$\sqrt{x^2 + x - 1} = -4x + 3 \quad -4\left(\frac{2}{3}\right) + 3 \geq 0$$

$$x^2 + x - 1 = 16x^2 - 24x + 9 \quad \frac{1}{3} \geq 0$$

$$0 = 15x^2 - 25x + 10$$

$$0 = 3x^2 - 5x + 2 \quad -4(1) + 3 < 0$$

$$0 = (3x - 2)(x - 1) \quad 1 \text{ is extraneous}$$

$$x = \frac{2}{3}, x \neq 1$$

PTS: 6

REF: 011339a2

STA: A2.A.22

TOP: Solving Radicals

KEY: extraneous solutions

346 ANS:

$$\left(-\frac{9}{2}, \frac{1}{2}\right) \text{ and } \left(\frac{1}{2}, \frac{11}{2}\right). \quad y = x + 5 \quad . \quad 4x^2 + 17x - 4 = x + 5$$

$$y = 4x^2 + 17x - 4 \quad 4x^2 + 16x - 9 = 0$$

$$(2x + 9)(2x - 1) = 0$$

$$x = -\frac{9}{2} \text{ and } x = \frac{1}{2}$$

$$y = -\frac{9}{2} + 5 = \frac{1}{2} \text{ and } y = \frac{1}{2} + 5 = \frac{11}{2}$$

PTS: 6 REF: 061139a2 STA: A2.A.3 TOP: Quadratic-Linear Systems
 KEY: equations

347 ANS:

$$x = -\frac{1}{3}, -1 \quad \log_{x+3} \frac{x^3 + x - 2}{x} = 2$$

$$\frac{x^3 + x - 2}{x} = (x + 3)^2$$

$$\frac{x^3 + x - 2}{x} = x^2 + 6x + 9$$

$$x^3 + x - 2 = x^3 + 6x^2 + 9x$$

$$0 = 6x^2 + 8x + 2$$

$$0 = 3x^2 + 4x + 1$$

$$0 = (3x + 1)(x + 1)$$

$$x = -\frac{1}{3}, -1$$

PTS: 6 REF: 081039a2 STA: A2.A.28 TOP: Logarithmic Equations
 KEY: basic

348 ANS:

$$\frac{-2(x^2 + 6)}{x^4} \cdot \frac{x^2(x - 3) + 6(x - 3)}{x^2 - 4x} \cdot \frac{2x - 4}{x^4 - 3x^3} \div \frac{x^2 + 2x - 8}{16 - x^2}$$

$$\frac{(x^2 + 6)(x - 3)}{x(x - 4)} \cdot \frac{2(x - 2)}{x^3(x - 3)} \cdot \frac{(4 + x)(4 - x)}{(x + 4)(x - 2)}$$

$$\frac{-2(x^2 + 6)}{x^4}$$

PTS: 6 REF: 011239a2 STA: A2.A.16 TOP: Multiplication and Division of Rationals
 KEY: division

349 ANS:

$$\ln(T - T_0) = -kt + 4.718 \quad \ln(T - 68) = -0.104(10) + 4.718.$$

$$\ln(150 - 68) = -k(3) + 4.718 \quad \ln(T - 68) = 3.678$$

$$4.407 \approx -3k + 4.718 \quad T - 68 \approx 39.6$$

$$k \approx 0.104 \quad T \approx 108$$

PTS: 6 REF: 011139a2 STA: A2.A.28 TOP: Logarithmic Equations

KEY: advanced

350 ANS:

$$81^{x^3 + 2x^2} = 27^{\frac{5x}{3}}$$

$$\left(3^4\right)^{x^3 + 2x^2} = \left(3^3\right)^{\frac{5x}{3}}$$

$$3^{4x^3 + 8x^2} = 3^{5x}$$

$$4x^3 + 8x^2 - 5x = 0$$

$$x(4x^2 + 8x - 5) = 0$$

$$x(2x - 1)(2x + 5) = 0$$

$$x = 0, \frac{1}{2}, -\frac{5}{2}$$

PTS: 6 REF: 061239a2 STA: A2.A.27 TOP: Exponential Equations

KEY: common base not shown

351 ANS:

$$x^4 + 4x^3 + 4x^2 + 16x = 0$$

$$x(x^3 + 4x^2 + 4x + 16) = 0$$

$$x(x^2(x + 4) + 4(x + 4)) = 0$$

$$x(x^2 + 4)(x + 4) = 0$$

$$x = 0, \pm 2i, -4$$

PTS: 6 REF: 061339a2 STA: A2.A.26 TOP: Solving Polynomial Equations