

JEFFERSON MATH PROJECT

REGENTS BY TYPE

The NY Integrated Algebra Regents Exams
Fall 2007-August 2012

www.jmap.org

Dear Sir

I have to acknowledge the receipt of your favor of May 14. in which you mention that you have finished the 6. first books of Euclid, plane trigonometry, surveying & algebra and ask whether I think a further pursuit of that branch of science would be useful to you. there are some propositions in the latter books of Euclid, & some of Archimedes, which are useful, & I have no doubt you have been made acquainted with them. trigonometry, so far as this, is most valuable to every man, there is scarcely a day in which he will not resort to it for some of the purposes of common life. the science of calculation also is indispensable as far as the extraction of the square & cube roots; Algebra as far as the quadratic equation & the use of logarithms are often of value in ordinary cases: but all beyond these is but a luxury; a delicious luxury indeed; but not to be indulged in by one who is to have a profession to follow for his subsistence. in this light I view the conic sections, curves of the higher orders, perhaps even spherical trigonometry, Algebraical operations beyond the 2d dimension, and fluxions.

Letter from Thomas Jefferson to William G. Munford, Monticello, June 18, 1799.

Integrated Algebra Multiple Choice Regents Exam Questions

1 Which is the graph of $y = |x| + 2$?

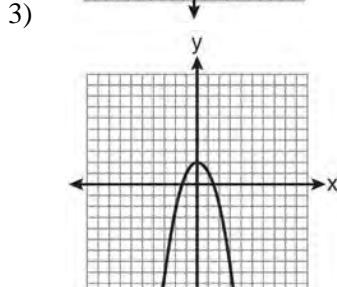
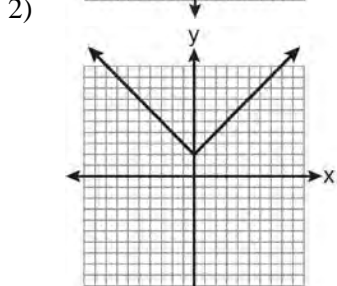
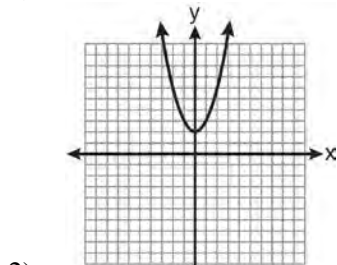
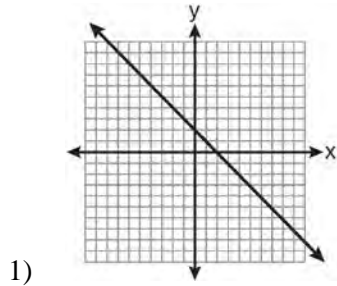

2 Which expression is equivalent to $121 - x^2$?

- 1) $(x - 11)(x - 11)$
- 2) $(x + 11)(x - 11)$
- 3) $(11 - x)(11 + x)$
- 4) $(11 - x)(11 - x)$

3 Which equation represents the line that passes through the points $(-3, 7)$ and $(3, 3)$?

- 1) $y = \frac{2}{3}x + 1$
- 2) $y = \frac{2}{3}x + 9$
- 3) $y = -\frac{2}{3}x + 5$
- 4) $y = -\frac{2}{3}x + 9$

4 Which ordered pair is in the solution set of the system of linear inequalities graphed below?

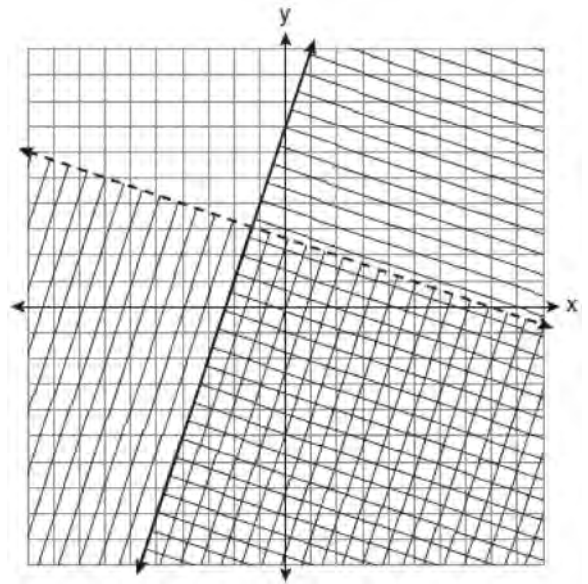

- 1) $(1, -4)$
- 2) $(-5, 7)$
- 3) $(5, 3)$
- 4) $(-7, -2)$

Integrated Algebra Multiple Choice Regents Exam Questions

www.jmap.org

- 5 In right triangle ABC shown below, $AB = 18.3$ and $BC = 11.2$.

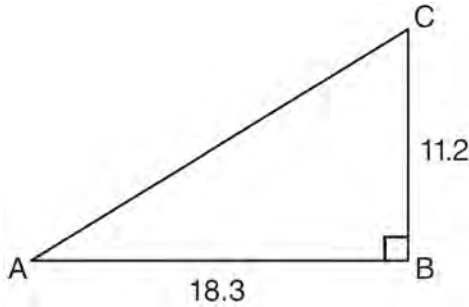

What is the measure of $\angle A$, to the nearest tenth of a degree?

- 1) 31.5
 - 2) 37.7
 - 3) 52.3
 - 4) 58.5
- 6 A formula used for calculating velocity is $v = \frac{1}{2}at^2$. What is a expressed in terms of v and t ?

- 1) $a = \frac{2v}{t}$
- 2) $a = \frac{2v}{t^2}$
- 3) $a = \frac{v}{t}$
- 4) $a = \frac{v}{2t^2}$

- 7 The maximum height and speed of various roller coasters in North America are shown in the table below.

Maximum Speed, in mph, (x)	45	50	54	60	65	70
Maximum Height, in feet, (y)	63	80	105	118	141	107

Which graph represents a correct scatter plot of the data?

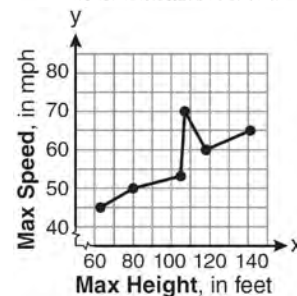
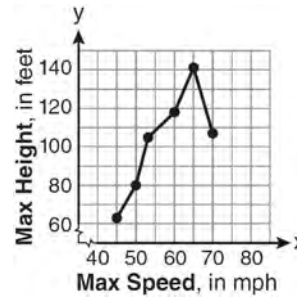
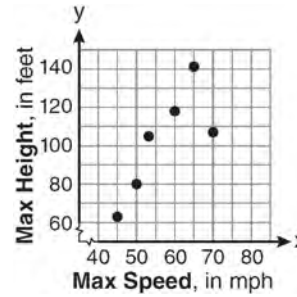
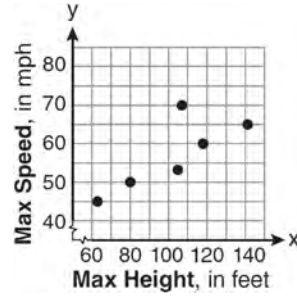

- 8 The graphs of the equations $y = 2x - 7$ and $y - kx = 7$ are parallel when k equals

- 1) -2
- 2) 2
- 3) -7
- 4) 7

Integrated Algebra Multiple Choice Regents Exam Questions

www.jmap.org

- 9 Based on the box-and-whisker plot below, which statement is *false*?

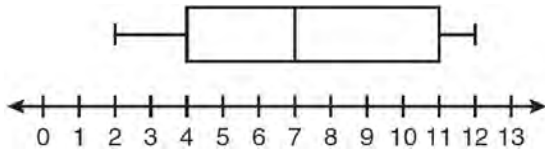

- 1) The median is 7.
- 2) The range is 12.
- 3) The first quartile is 4.
- 4) The third quartile is 11.

- 10 Given: $Q = \{0, 2, 4, 6\}$

$$W = \{0, 1, 2, 3\}$$

$$Z = \{1, 2, 3, 4\}$$

What is the intersection of sets Q , W , and Z ?

- 1) $\{2\}$
- 2) $\{0, 2\}$
- 3) $\{1, 2, 3\}$
- 4) $\{0, 1, 2, 3, 4, 6\}$

- 11 What is the quotient of $\frac{x}{x+4}$ divided by $\frac{2x}{x^2-16}$?

- 1) $\frac{2}{x-4}$
- 2) $\frac{2x^2}{x-4}$
- 3) $\frac{2x^2}{x^2-16}$
- 4) $\frac{x-4}{2}$

- 12 What is the slope of the line that passes through the points $(3, 5)$ and $(-2, 2)$?

- 1) $\frac{1}{5}$
- 2) $\frac{3}{5}$
- 3) $\frac{5}{3}$
- 4) 5

- 13 Which ratio represents $\sin x$ in the right triangle shown below?

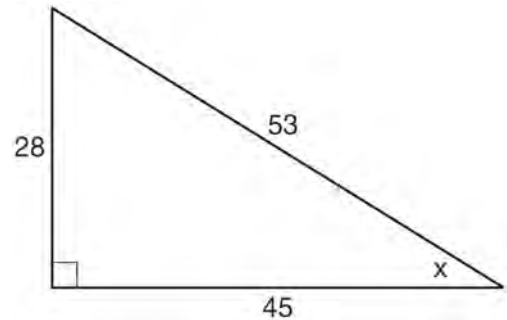

- 1) $\frac{28}{53}$
- 2) $\frac{28}{45}$
- 3) $\frac{45}{53}$
- 4) $\frac{53}{28}$

- 14 When $5x + 4y$ is subtracted from $5x - 4y$, the difference is

- 1) 0
- 2) $10x$
- 3) $8y$
- 4) $-8y$

Integrated Algebra Multiple Choice Regents Exam Questions

www.jmap.org

15 What is the value of the expression $-3x^2y + 4x$ when $x = -4$ and $y = 2$?

- 1) -112
- 2) -80
- 3) 80
- 4) 272

16 A hiker walked 12.8 miles from 9:00 a.m. to noon. He walked an additional 17.2 miles from 1:00 p.m. to 6:00 p.m. What is his average rate for the entire walk, in miles per hour?

- 1) 3.75
- 2) 3.86
- 3) 4.27
- 4) 7.71

17 The height, y , of a ball tossed into the air can be represented by the equation $y = -x^2 + 10x + 3$, where x is the elapsed time. What is the equation of the axis of symmetry of this parabola?

- 1) $y = 5$
- 2) $y = -5$
- 3) $x = 5$
- 4) $x = -5$

18 What is the sum of $\frac{3x^2}{x-2}$ and $\frac{x^2}{x-2}$?

- 1) $\frac{3x^4}{(x-2)^2}$
- 2) $\frac{3x^4}{x-2}$
- 3) $\frac{4x^2}{(x-2)^2}$
- 4) $\frac{4x^2}{x-2}$

19 What is the range of the data represented in the box-and-whisker plot shown below?

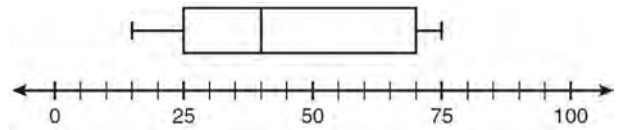

- 1) 40
- 2) 45
- 3) 60
- 4) 100

20 What is the slope of the line whose equation is $3x - 7y = 9$?

- 1) $-\frac{3}{7}$
- 2) $\frac{3}{7}$
- 3) $-\frac{7}{3}$
- 4) $\frac{7}{3}$

21 Michael is 25 years younger than his father. The sum of their ages is 53. What is Michael's age?

- 1) 14
- 2) 25
- 3) 28
- 4) 39

22 How many square inches of wrapping paper are needed to entirely cover a box that is 2 inches by 3 inches by 4 inches?

- 1) 18
- 2) 24
- 3) 26
- 4) 52

Integrated Algebra Multiple Choice Regents Exam Questions

www.jmap.org

- 23 What is the relationship between the independent and dependent variables in the scatter plot shown below?

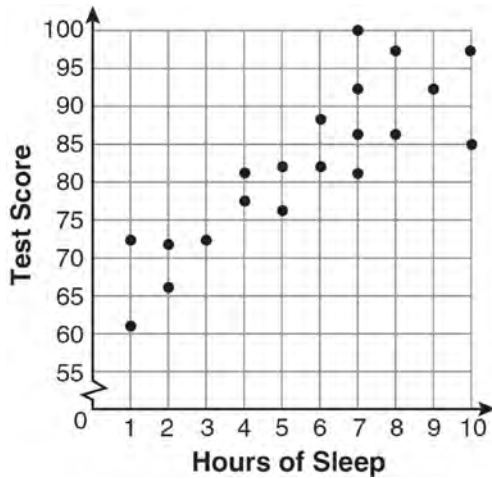

- 1) undefined correlation
 2) negative correlation
 3) positive correlation
 4) no correlation
- 24 If Ann correctly factors an expression that is the difference of two perfect squares, her factors could be
- 1) $(2x + y)(x - 2y)$
 2) $(2x + 3y)(2x - 3y)$
 3) $(x - 4)(x - 4)$
 4) $(2y - 5)(y - 5)$
- 25 Roger is having a picnic for 78 guests. He plans to serve each guest at least one hot dog. If each package, p , contains eight hot dogs, which inequality could be used to determine how many packages of hot dogs Roger will need to buy?
- 1) $p \geq 78$
 2) $8p \geq 78$
 3) $8 + p \geq 78$
 4) $78 - p \geq 8$

- 26 Ben has four more than twice as many CDs as Jake. If they have a total of 31 CDs, how many CDs does Jake have?
- 1) 9
 2) 13
 3) 14
 4) 22
- 27 In $\triangle ABC$, the measure of $\angle B = 90^\circ$, $AC = 50$, $AB = 48$, and $BC = 14$. Which ratio represents the tangent of $\angle A$?
- 1) $\frac{14}{50}$
 2) $\frac{14}{48}$
 3) $\frac{48}{50}$
 4) $\frac{48}{14}$
- 28 Tim ate four more cookies than Alice. Bob ate twice as many cookies as Tim. If x represents the number of cookies Alice ate, which expression represents the number of cookies Bob ate?
- 1) $2 + (x + 4)$
 2) $2x + 4$
 3) $2(x + 4)$
 4) $4(x + 2)$
- 29 The width of a rectangle is 3 less than twice the length, x . If the area of the rectangle is 43 square feet, which equation can be used to find the length, in feet?
- 1) $2x(x - 3) = 43$
 2) $x(3 - 2x) = 43$
 3) $2x + 2(2x - 3) = 43$
 4) $x(2x - 3) = 43$

Integrated Algebra Multiple Choice Regents Exam Questions

www.jmap.org

- 30 The dimensions of a rectangle are measured to be 12.2 inches by 11.8 inches. The actual dimensions are 12.3 inches by 11.9 inches. What is the relative error, to the *nearest ten-thousandth*, in calculating the area of the rectangle?
- 1) 0.0168
 - 2) 0.0167
 - 3) 0.0165
 - 4) 0.0164

- 32 What is the sum of $\frac{-x+7}{2x+4}$ and $\frac{2x+5}{2x+4}$?
- 1) $\frac{x+12}{2x+4}$
 - 2) $\frac{3x+12}{2x+4}$
 - 3) $\frac{x+12}{4x+8}$
 - 4) $\frac{3x+12}{4x+8}$

- 31 The scatter plot below represents the relationship between the number of peanuts a student eats and the student's bowling score.

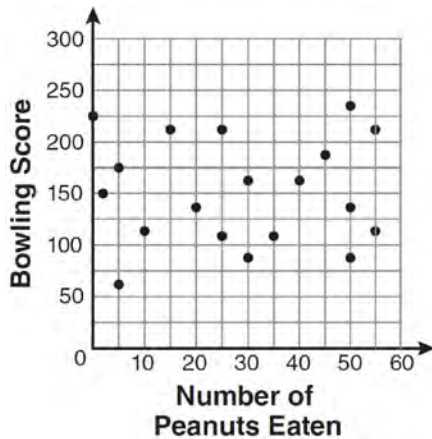

- Which conclusion about the scatter plot is valid?
- 1) There is almost no relationship between eating peanuts and bowling score.
 - 2) Students who eat more peanuts have higher bowling scores.
 - 3) Students who eat more peanuts have lower bowling scores.
 - 4) No bowlers eat peanuts.

- 33 Which ordered pair is a solution of the system of equations shown in the graph below?

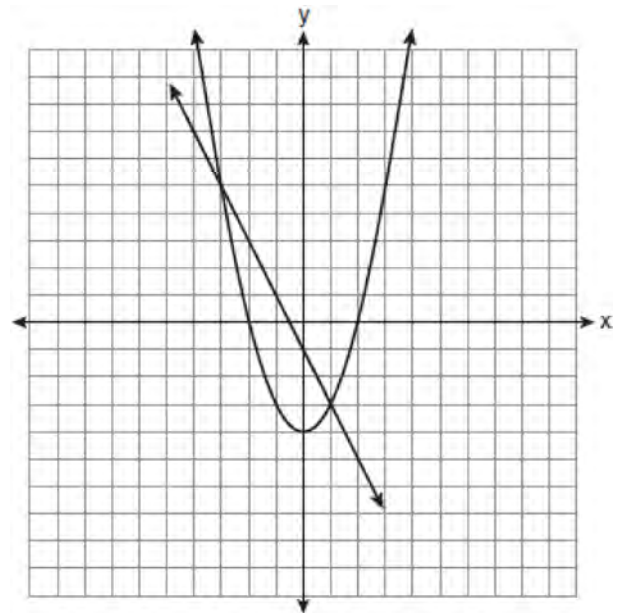

- 1) (-3, 1)
- 2) (-3, 5)
- 3) (0, -1)
- 4) (0, -4)

Integrated Algebra Multiple Choice Regents Exam Questions

www.jmap.org

- 34 Which situation does *not* describe a causal relationship?
- 1) The higher the volume on a radio, the louder the sound will be.
 - 2) The faster a student types a research paper, the more pages the paper will have.
 - 3) The shorter the distance driven, the less gasoline that will be used.
 - 4) The slower the pace of a runner, the longer it will take the runner to finish the race.
- 35 Given: $X = \{1, 2, 3, 4\}$
 $Y = \{2, 3, 4, 5\}$
 $Z = \{3, 4, 5, 6\}$
What is the intersection of sets X , Y , and Z ?
- 1) $\{3, 4\}$
 - 2) $\{2, 3, 4\}$
 - 3) $\{3, 4, 5\}$
 - 4) $\{1, 2, 3, 4, 5, 6\}$
- 36 Jack wants to replace the flooring in his rectangular kitchen. He calculates the area of the floor to be 12.8 square meters. The actual area of the floor is 13.5 square meters. What is the relative error in calculating the area of the floor, to the *nearest thousandth*?
- 1) 0.051
 - 2) 0.052
 - 3) 0.054
 - 4) 0.055
- 37 Which relation represents a function?
- 1) $\{(0, 3), (2, 4), (0, 6)\}$
 - 2) $\{(-7, 5), (-7, 1), (-10, 3), (-4, 3)\}$
 - 3) $\{(2, 0), (6, 2), (6, -2)\}$
 - 4) $\{(-6, 5), (-3, 2), (1, 2), (6, 5)\}$
- 38 Which interval notation represents the set of all real numbers greater than 2 and less than or equal to 20?
- 1) $(2, 20)$
 - 2) $(2, 20]$
 - 3) $[2, 20)$
 - 4) $[2, 20]$
- 39 The expression $\frac{12w^9y^3}{-3w^3y^3}$ is equivalent to
- 1) $-4w^6$
 - 2) $-4w^3y$
 - 3) $9w^6$
 - 4) $9w^3y$
- 40 In a recent town election, 1,860 people voted for either candidate A or candidate B for the position of supervisor. If candidate A received 55% of the votes, how many votes did candidate B receive?
- 1) 186
 - 2) 837
 - 3) 1,023
 - 4) 1,805
- 41 What is $\frac{2+x}{5x} - \frac{x-2}{5x}$ expressed in simplest form?
- 1) 0
 - 2) $\frac{2}{5}$
 - 3) $\frac{4}{5x}$
 - 4) $\frac{2x+4}{5x}$

Integrated Algebra Multiple Choice Regents Exam Questions

www.jmap.org

42 Which relation is a function?

- 1) $\left\{\left(\frac{3}{4}, 0\right), (0, 1), \left(\frac{3}{4}, 2\right)\right\}$
- 2) $\left\{(-2, 2), \left(-\frac{1}{2}, 1\right), (-2, 4)\right\}$
- 3) $\{(-1, 4), (0, 5), (0, 4)\}$
- 4) $\{(2, 1), (4, 3), (6, 5)\}$

43 Which ordered pair is a solution to the system of equations $y = x + 3$ and $y = x^2 - x$?

- 1) (6, 9)
- 2) (3, 6)
- 3) (3, -1)
- 4) (2, 5)

44 Which value of x is the solution of $\frac{x}{3} + \frac{x+1}{2} = x$?

- 1) 1
- 2) -1
- 3) 3
- 4) -3

45 Which equation represents a line parallel to the graph of $2x - 4y = 16$?

- 1) $y = \frac{1}{2}x - 5$
- 2) $y = -\frac{1}{2}x + 4$
- 3) $y = -2x + 6$
- 4) $y = 2x + 8$

46 Three high school juniors, Reese, Matthew, and Chris, are running for student council president. A survey is taken a week before the election asking 40 students which candidate they will vote for in the election. The results are shown in the table below.

Candidate's Name	Number of Students Supporting Candidate
Reese	15
Matthew	13
Chris	12

Based on the table, what is the probability that a student will vote for Reese?

- 1) $\frac{1}{3}$
- 2) $\frac{3}{5}$
- 3) $\frac{3}{8}$
- 4) $\frac{5}{8}$

47 The expression $\sqrt{72} - 3\sqrt{2}$ written in simplest radical form is

- 1) $5\sqrt{2}$
- 2) $3\sqrt{6}$
- 3) $3\sqrt{2}$
- 4) $\sqrt{6}$

Integrated Algebra Multiple Choice Regents Exam Questions

www.jmap.org

48 A bag contains eight green marbles, five white marbles, and two red marbles. What is the probability of drawing a red marble from the bag?

- 1) $\frac{1}{15}$
- 2) $\frac{2}{15}$
- 3) $\frac{2}{13}$
- 4) $\frac{13}{15}$

49 In a science fiction novel, the main character found a mysterious rock that decreased in size each day. The table below shows the part of the rock that remained at noon on successive days.

Day	Fractional Part of the Rock Remaining
1	1
2	$\frac{1}{2}$
3	$\frac{1}{4}$
4	$\frac{1}{8}$

Which fractional part of the rock will remain at noon on day 7?

- 1) $\frac{1}{128}$
- 2) $\frac{1}{64}$
- 3) $\frac{1}{14}$
- 4) $\frac{1}{12}$

50 Which expression represents $\frac{12x^3 - 6x^2 + 2x}{2x}$ in simplest form?

- 1) $6x^2 - 3x$
- 2) $10x^2 - 4x$
- 3) $6x^2 - 3x + 1$
- 4) $10x^2 - 4x + 1$

51 Which quadrant will be completely shaded in the graph of the inequality $y \leq 2x$?

- 1) Quadrant I
- 2) Quadrant II
- 3) Quadrant III
- 4) Quadrant IV

52 The current student population of the Brentwood Student Center is 2,000. The enrollment at the center increases at a rate of 4% each year. To the nearest whole number, what will the student population be closest to in 3 years?

- 1) 2,240
- 2) 2,250
- 3) 5,488
- 4) 6,240

53 What is $\frac{7}{12x} - \frac{y}{6x^2}$ expressed in simplest form?

- 1) $\frac{7-y}{6x}$
- 2) $\frac{7-y}{12x - 6x^2}$
- 3) $-\frac{7y}{12x^2}$
- 4) $\frac{7x-2y}{12x^2}$

Integrated Algebra Multiple Choice Regents Exam Questions

www.jmap.org

54 Which expression is equivalent to $-3x(x - 4) - 2x(x + 3)$?

- 1) $-x^2 - 1$
- 2) $-x^2 + 18x$
- 3) $-5x^2 - 6x$
- 4) $-5x^2 + 6x$

55 Steve ran a distance of 150 meters in $1\frac{1}{2}$ minutes.

What is his speed in meters per hour?

- 1) 6
- 2) 60
- 3) 100
- 4) 6,000

56 The freshman class held a canned food drive for 12 weeks. The results are summarized in the table below.

Canned Food Drive Results

Week	1	2	3	4	5	6	7	8	9	10	11	12
Number of Cans	20	35	32	45	58	46	28	23	31	79	65	62

Which number represents the second quartile of the number of cans of food collected?

- 1) 29.5
- 2) 30.5
- 3) 40
- 4) 60

57 What is $3\sqrt{250}$ expressed in simplest radical form?

- 1) $5\sqrt{10}$
- 2) $8\sqrt{10}$
- 3) $15\sqrt{10}$
- 4) $75\sqrt{10}$

58 What is the slope of the line passing through the points A and B, as shown on the graph below?

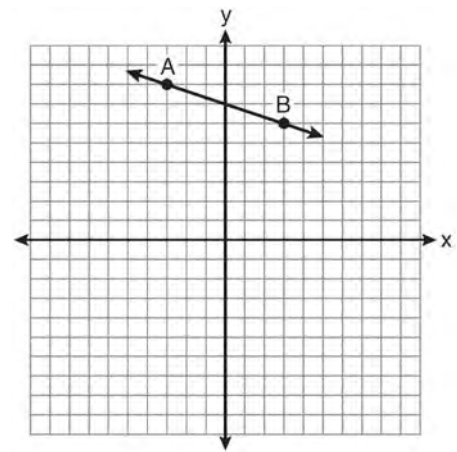

- 1) -3
- 2) $-\frac{1}{3}$
- 3) 3
- 4) $\frac{1}{3}$

59 Which verbal expression is represented by $\frac{1}{2}(n - 3)$?

- 1) one-half n decreased by 3
- 2) one-half n subtracted from 3
- 3) the difference of one-half n and 3
- 4) one-half the difference of n and 3

Integrated Algebra Multiple Choice Regents Exam Questions

www.jmap.org

- 60 A student correctly graphed the parabola shown below to solve a given quadratic equation.

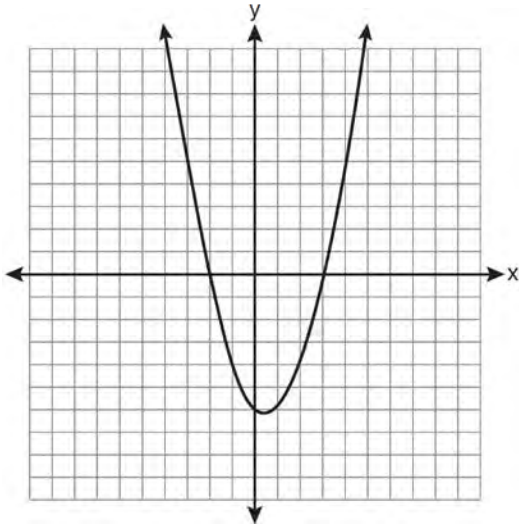

What are the roots of the quadratic equation associated with this graph?

- 1) -6 and 3
 - 2) -6 and 0
 - 3) -3 and 2
 - 4) -2 and 3
- 61 What is the result when $2x^2 + 3xy - 6$ is subtracted from $x^2 - 7xy + 2$?

- 1) $-x^2 - 10xy + 8$
- 2) $x^2 + 10xy - 8$
- 3) $-x^2 - 4xy - 4$
- 4) $x^2 - 4xy - 4$

- 62 Which equation illustrates the associative property?

- 1) $x + y + z = x + y + z$
- 2) $x(y + z) = xy + xz$
- 3) $x + y + z = z + y + x$
- 4) $(x + y) + z = x + (y + z)$

- 63 Which graph represents a function?

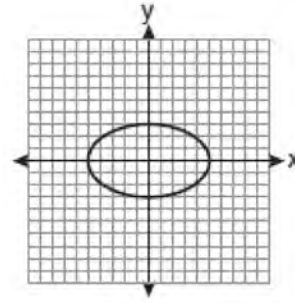

1)

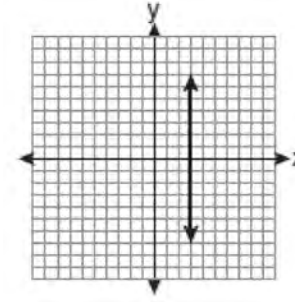

2)

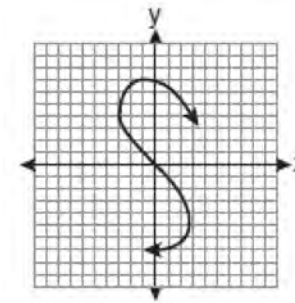

3)

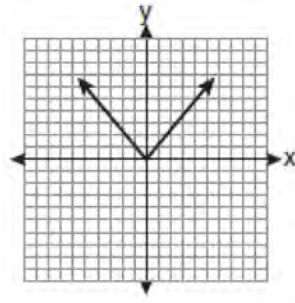

4)

Integrated Algebra Multiple Choice Regents Exam Questions

www.jmap.org

- 64 The value, y , of a \$15,000 investment over x years is represented by the equation $y = 15000(1.2)^{\frac{x}{3}}$. What is the profit (interest) on a 6-year investment?
- 1) \$6,600
 - 2) \$10,799
 - 3) \$21,600
 - 4) \$25,799

- 65 The rectangle shown below has a diagonal of 18.4 cm and a width of 7 cm.

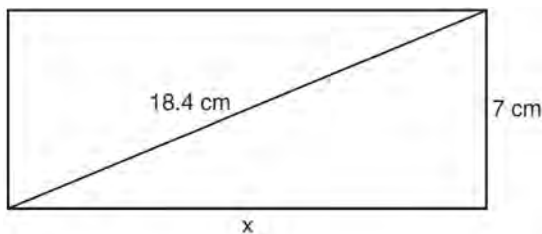

To the *nearest centimeter*, what is the length, x , of the rectangle?

- 1) 11
 - 2) 17
 - 3) 20
 - 4) 25
- 66 An example of an algebraic expression is
- 1) $y = mx + b$
 - 2) $3x + 4y - 7$
 - 3) $2x + 3y \leq 18$
 - 4) $(x + y)(x - y) = 25$
- 67 What is the solution of $3(2m - 1) \leq 4m + 7$?
- 1) $m \leq 5$
 - 2) $m \geq 5$
 - 3) $m \leq 4$
 - 4) $m \geq 4$

- 68 What is the equation of the axis of symmetry of the parabola shown in the diagram below?

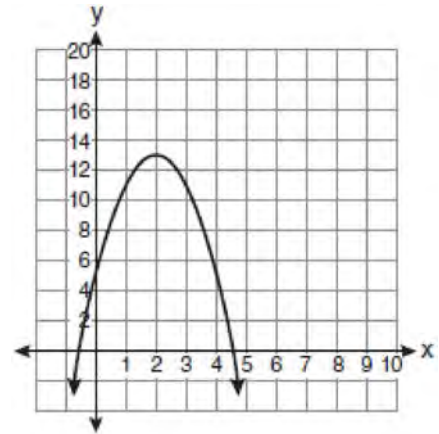

- 1) $x = -0.5$
 - 2) $x = 2$
 - 3) $x = 4.5$
 - 4) $x = 13$
- 69 How many different sandwiches consisting of one type of cheese, one condiment, and one bread choice can be prepared from five types of cheese, two condiments, and three bread choices?
- 1) 10
 - 2) 13
 - 3) 15
 - 4) 30
- 70 Given: $U = \{1, 2, 3, 4, 5, 6, 7, 8\}$
 $B = \{2, 3, 5, 6\}$
 Set B is a subset of set U . What is the complement of set B ?
- 1) $\{ \}$
 - 2) $\{2, 3, 5, 6\}$
 - 3) $\{1, 4, 7, 8\}$
 - 4) $\{1, 2, 3, 4, 5, 6, 7, 8\}$

Integrated Algebra Multiple Choice Regents Exam Questions

www.jmap.org

- 71 Which situation describes a correlation that is *not* a causal relationship?
- 1) the length of the edge of a cube and the volume of the cube
 - 2) the distance traveled and the time spent driving
 - 3) the age of a child and the number of siblings the child has
 - 4) the number of classes taught in a school and the number of teachers employed
- 72 Factored completely, the expression $3x^2 - 3x - 18$ is equivalent to
- 1) $3(x^2 - x - 6)$
 - 2) $3(x - 3)(x + 2)$
 - 3) $(3x - 9)(x + 2)$
 - 4) $(3x + 6)(x - 3)$
- 73 The expression $\frac{(10w^3)^2}{5w}$ is equivalent to
- 1) $2w^5$
 - 2) $2w^8$
 - 3) $20w^5$
 - 4) $20w^8$
- 74 The sum of $4x^3 + 6x^2 + 2x - 3$ and $3x^3 + 3x^2 - 5x - 5$ is
- 1) $7x^3 + 3x^2 - 3x - 8$
 - 2) $7x^3 + 3x^2 + 7x + 2$
 - 3) $7x^3 + 9x^2 - 3x - 8$
 - 4) $7x^6 + 9x^4 - 3x^2 - 8$
- 75 The number of calories burned while jogging varies directly with the number of minutes spent jogging. If George burns 150 calories by jogging for 20 minutes, how many calories does he burn by jogging for 30 minutes?
- 1) 100
 - 2) 180
 - 3) 200
 - 4) 225
- 76 Which ordered pair is in the solution set of the following system of linear inequalities?
- $$y < 2x + 2$$
- $$y \geq -x - 1$$
- 1) (0,3)
 - 2) (2,0)
 - 3) (-1,0)
 - 4) (-1,-4)
- 77 A study showed that a decrease in the cost of carrots led to an increase in the number of carrots sold. Which statement best describes this relationship?
- 1) positive correlation and a causal relationship
 - 2) negative correlation and a causal relationship
 - 3) positive correlation and not a causal relationship
 - 4) negative correlation and not a causal relationship
- 78 The algebraic expression $\frac{x-2}{x^2-9}$ is undefined when x is
- 1) 0
 - 2) 2
 - 3) 3
 - 4) 9

Integrated Algebra Multiple Choice Regents Exam Questions

www.jmap.org

- 79 Which graph could be used to find the solution of the system of equations $y = 2x + 6$ and $y = x^2 + 4x + 3$?

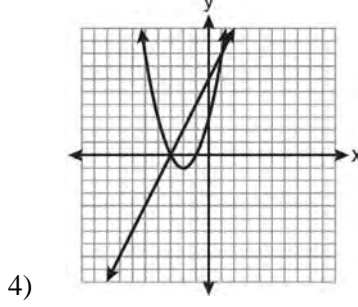
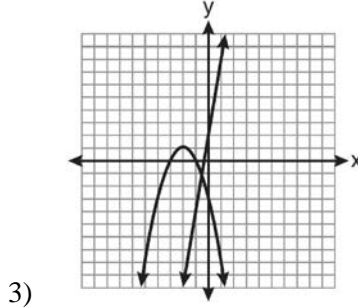
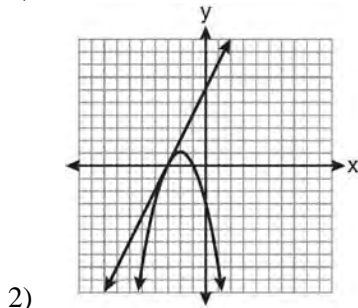
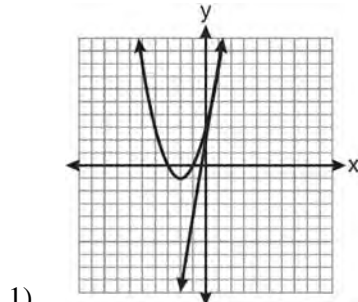

- 80 Four hundred licensed drivers participated in the math club's survey on driving habits. The table below shows the number of drivers surveyed in each age group.

Ages of People in Survey on Driving Habits

Age Group	Number of Drivers
16-25	150
26-35	129
36-45	33
46-55	57
56-65	31

Which statement best describes a conclusion based on the data in the table?

- 1) It may be biased because no one younger than 16 was surveyed.
 - 2) It would be fair because many different age groups were surveyed.
 - 3) It would be fair because the survey was conducted by the math club students.
 - 4) It may be biased because the majority of drivers surveyed were in the younger age intervals.
- 81 Which set of data can be classified as qualitative?
- 1) scores of students in an algebra class
 - 2) ages of students in a biology class
 - 3) numbers of students in history classes
 - 4) eye colors of students in an economics class
- 82 A cylinder has a diameter of 10 inches and a height of 2.3 inches. What is the volume of this cylinder, to the *nearest tenth of a cubic inch*?
- 1) 72.3
 - 2) 83.1
 - 3) 180.6
 - 4) 722.6

Integrated Algebra Multiple Choice Regents Exam Questions

www.jmap.org

83 The diagram below shows the graph of $y = -x^2 - c$.

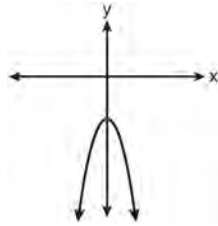

Which diagram shows the graph of $y = x^2 - c$?

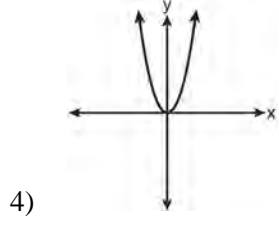
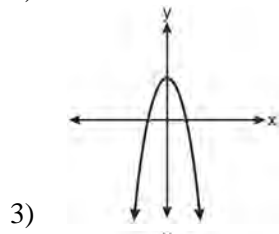
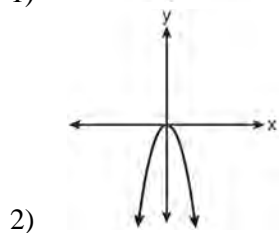
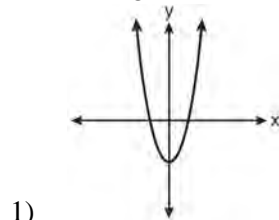

84 A garden is in the shape of an isosceles trapezoid and a semicircle, as shown in the diagram below. A fence will be put around the perimeter of the entire garden.

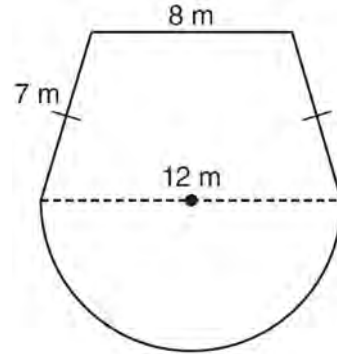

Which expression represents the length of fencing, in meters, that will be needed?

- 1) $22 + 6\pi$
- 2) $22 + 12\pi$
- 3) $15 + 6\pi$
- 4) $15 + 12\pi$

85 Debbie solved the linear equation $3(x + 4) - 2 = 16$ as follows:

[Line 1] $3(x + 4) - 2 = 16$

[Line 2] $3(x + 4) = 18$

[Line 3] $3x + 4 = 18$

[Line 4] $3x = 14$

[Line 5] $x = 4\frac{2}{3}$

She made an error between lines

- 1) 1 and 2
- 2) 2 and 3
- 3) 3 and 4
- 4) 4 and 5

Integrated Algebra Multiple Choice Regents Exam Questions

www.jmap.org

- 86 The figure shown below is composed of two rectangles and a quarter circle.

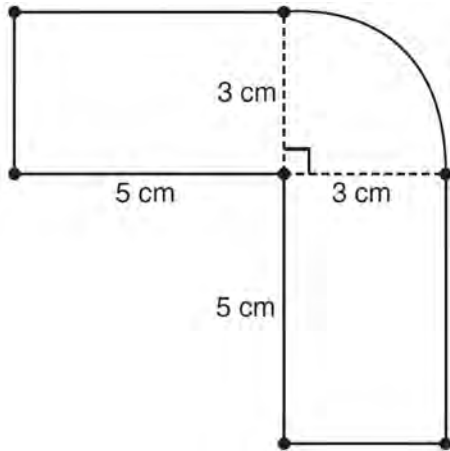

What is the area of this figure, to the nearest square centimeter?

- 1) 33
 - 2) 37
 - 3) 44
 - 4) 58
- 87 How many different ways can five books be arranged on a shelf?
- 1) 5
 - 2) 15
 - 3) 25
 - 4) 120
- 88 Which phrase best describes the relationship between the number of miles driven and the amount of gasoline used?
- 1) causal, but not correlated
 - 2) correlated, but not causal
 - 3) both correlated and causal
 - 4) neither correlated nor causal

- 89 The diagram below shows right triangle ABC .

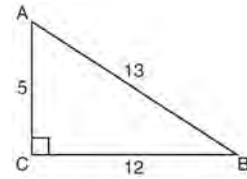

Which ratio represents the tangent of $\angle ABC$?

- 1) $\frac{5}{13}$
 - 2) $\frac{5}{12}$
 - 3) $\frac{12}{13}$
 - 4) $\frac{12}{5}$
- 90 What is an equation of the line that passes through the points $(1,3)$ and $(8,5)$?
- 1) $y + 1 = \frac{2}{7}(x + 3)$
 - 2) $y - 5 = \frac{2}{7}(x - 8)$
 - 3) $y - 1 = \frac{2}{7}(x + 3)$
 - 4) $y + 5 = \frac{2}{7}(x - 8)$
- 91 Josh and Mae work at a concession stand. They each earn \$8 per hour. Josh worked three hours more than Mae. If Josh and Mae earned a total of \$120, how many hours did Josh work?
- 1) 6
 - 2) 9
 - 3) 12
 - 4) 15

Integrated Algebra Multiple Choice Regents Exam Questions

www.jmap.org

- 92 A spinner that is equally divided into eight numbered sectors is spun 20 times. The table below shows the number of times the arrow landed in each numbered sector.

Spinner Sector	Number of Times
1	2
2	3
3	2
4	3
5	4
6	2
7	3
8	1

Based on the table, what is the empirical probability that the spinner will land on a prime number on the next spin?

- 1) $\frac{9}{20}$
 - 2) $\frac{11}{20}$
 - 3) $\frac{12}{20}$
 - 4) $\frac{14}{20}$
- 93 Corinne calculated the area of a paper plate to be 50.27 square inches. If the actual area of the plate is 55.42 square inches, what is the relative error in calculating the area, to the *nearest thousandth*?
- 1) 0.092
 - 2) 0.093
 - 3) 0.102
 - 4) 0.103

- 94 What is the value of the expression $(a^3 + b^0)^2$ when $a = -2$ and $b = 4$?
- 1) 64
 - 2) 49
 - 3) -49
 - 4) -64

- 95 An 8-foot rope is tied from the top of a pole to a stake in the ground, as shown in the diagram below.

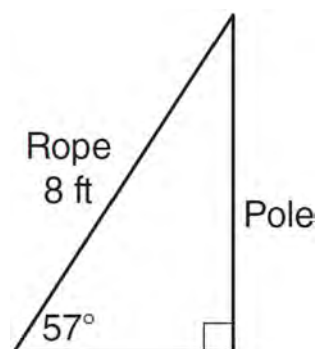

If the rope forms a 57° angle with the ground, what is the height of the pole, to the *nearest tenth of a foot*?

- 1) 4.4
 - 2) 6.7
 - 3) 9.5
 - 4) 12.3
- 96 What is the slope of the line passing through the points $(-2, 4)$ and $(3, 6)$?
- 1) $-\frac{5}{2}$
 - 2) $-\frac{2}{5}$
 - 3) $\frac{2}{5}$
 - 4) $\frac{5}{2}$

Integrated Algebra Multiple Choice Regents Exam Questions

www.jmap.org

- 97 Which ordered pair is in the solution set of the system of inequalities shown in the graph below?

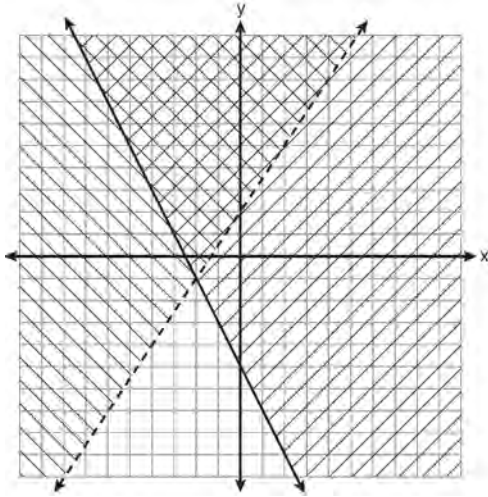

- 1) $(-2, -1)$
- 2) $(-2, 2)$
- 3) $(-2, -4)$
- 4) $(2, -2)$

- 98 Which equation shows a correct trigonometric ratio for angle A in the right triangle below?

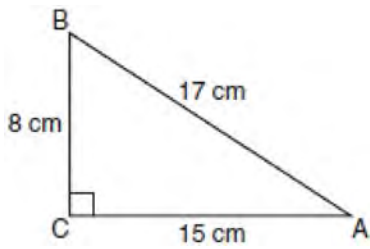

- 1) $\sin A = \frac{15}{17}$
- 2) $\tan A = \frac{8}{17}$
- 3) $\cos A = \frac{15}{17}$
- 4) $\tan A = \frac{5}{8}$

- 99 The school store did a study comparing the cost of a sweatshirt with the number of sweatshirts sold. The price was changed several times and the numbers of sweatshirts sold were recorded. The data are shown in the table below.

Cost of Sweatshirt	\$10	\$25	\$15	\$20	\$5
Number Sold	9	6	15	11	14

Which scatter plot represents the data?

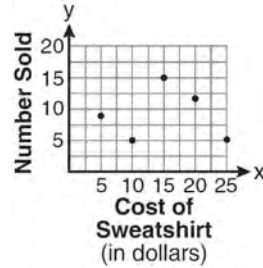

1)

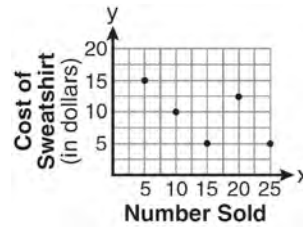

2)

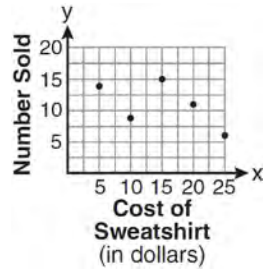

3)

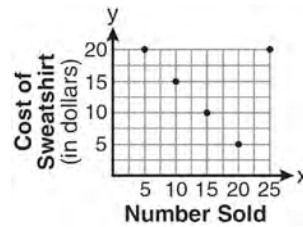

4)

Integrated Algebra Multiple Choice Regents Exam Questions

www.jmap.org

100 What are the roots of the equation $x^2 - 5x + 6 = 0$?

- 1) 1 and -6
- 2) 2 and 3
- 3) -1 and 6
- 4) -2 and -3

101 What is the product of (6×10^3) , (4.6×10^5) , and (2×10^{-2}) expressed in scientific notation?

- 1) 55.2×10^6
- 2) 5.52×10^7
- 3) 55.2×10^7
- 4) 5.52×10^{10}

102 What is the solution of the inequality $-6x - 17 \geq 8x + 25$?

- 1) $x \geq 3$
- 2) $x \leq 3$
- 3) $x \geq -3$
- 4) $x \leq -3$

103 Which expression is equivalent to $3^3 \cdot 3^4$?

- 1) 9^{12}
- 2) 9^7
- 3) 3^{12}
- 4) 3^7

104 Which notation describes $\{1, 2, 3\}$?

- 1) $\{x \mid 1 \leq x < 3, \text{ where } x \text{ is an integer}\}$
- 2) $\{x \mid 0 < x \leq 3, \text{ where } x \text{ is an integer}\}$
- 3) $\{x \mid 1 < x < 3, \text{ where } x \text{ is an integer}\}$
- 4) $\{x \mid 0 \leq x \leq 3, \text{ where } x \text{ is an integer}\}$

105 Which set represents the intersection of sets A, B, and C shown in the diagram below?

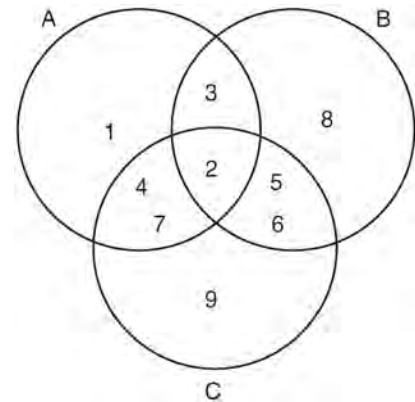

- 1) $\{3, 4, 5, 6, 7\}$
- 2) $\{2\}$
- 3) $\{2, 3, 4, 5, 6, 7\}$
- 4) $\{1, 2, 3, 4, 5, 6, 7, 8, 9\}$

106 The box-and-whisker plot below represents the math test scores of 20 students.

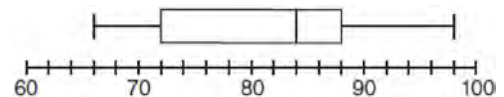

What percentage of the test scores are *less than 72*?

- 1) 25
- 2) 50
- 3) 75
- 4) 100

107 The legs of an isosceles right triangle each measure 10 inches. What is the length of the hypotenuse of this triangle, to the *nearest tenth of an inch*?

- 1) 6.3
- 2) 7.1
- 3) 14.1
- 4) 17.1

Integrated Algebra Multiple Choice Regents Exam Questions

www.jmap.org

- 108 The graph of the equation $y = |x|$ is shown in the diagram below.

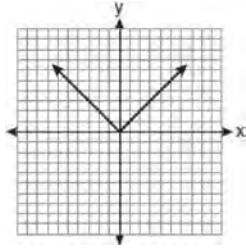

Which diagram could represent a graph of the equation $y = a|x|$ when $-1 < a < 0$?

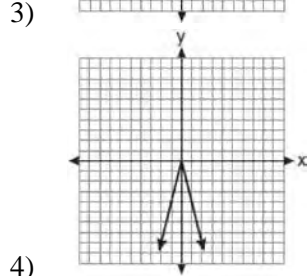
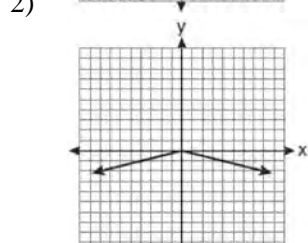
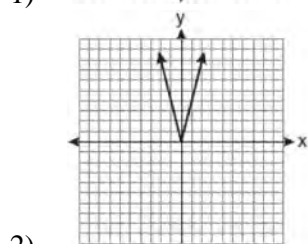
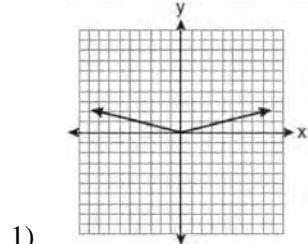

- 109 What are the factors of the expression $x^2 + x - 20$?
- 1) $(x + 5)$ and $(x + 4)$
 - 2) $(x + 5)$ and $(x - 4)$
 - 3) $(x - 5)$ and $(x + 4)$
 - 4) $(x - 5)$ and $(x - 4)$

- 110 Which linear equation represents a line containing the point $(1, 3)$?

- 1) $x + 2y = 5$
- 2) $x - 2y = 5$
- 3) $2x + y = 5$
- 4) $2x - y = 5$

- 111 An example of an algebraic expression is

- 1) $x + 2$
- 2) $y = x + 2$
- 3) $y < x + 2$
- 4) $y = x^2 + 2x$

- 112 Julia went to the movies and bought one jumbo popcorn and two chocolate chip cookies for \$5.00. Marvin went to the same movie and bought one jumbo popcorn and four chocolate chip cookies for \$6.00. How much does one chocolate chip cookie cost?

- 1) \$0.50
- 2) \$0.75
- 3) \$1.00
- 4) \$2.00

Integrated Algebra Multiple Choice Regents Exam Questions

www.jmap.org

113 What is the value of x in the equation

$$2(x - 4) = 4(2x + 1)?$$

- 1) -2
- 2) 2
- 3) $-\frac{1}{2}$
- 4) $\frac{1}{2}$

114 The data in the table below are graphed, and the slope is examined.

x	y
0.5	9.0
1	8.75
1.5	8.5
2	8.25
2.5	8.0

The rate of change represented in this table can be described as

- 1) negative
- 2) positive
- 3) undefined
- 4) zero

115 Sam's grades on eleven chemistry tests were 90, 85, 76, 63, 94, 89, 81, 76, 78, 69, and 97. Which statement is true about the measures of central tendency?

- 1) mean $>$ mode
- 2) mean $<$ median
- 3) mode $>$ median
- 4) median = mean

116 The ninth grade class at a local high school needs to purchase a park permit for \$250.00 for their upcoming class picnic. Each ninth grader attending the picnic pays \$0.75. Each guest pays \$1.25. If 200 ninth graders attend the picnic, which inequality can be used to determine the number of guests, x , needed to cover the cost of the permit?

- 1) $0.75x - (1.25)(200) \geq 250.00$
- 2) $0.75x + (1.25)(200) \geq 250.00$
- 3) $(0.75)(200) - 1.25x \geq 250.00$
- 4) $(0.75)(200) + 1.25x \geq 250.00$

117 Which table does *not* show bivariate data?

1)

Height (inches)	Weight (pounds)
39	50
48	70
60	90

2)

Gallons	Miles Driven
15	300
20	400
25	500

3)

Quiz Average	Frequency
70	12
80	15
90	6

4)

Speed (mph)	Distance (miles)
40	80
50	120
55	150

Integrated Algebra Multiple Choice Regents Exam Questions

www.jmap.org

- 118 Which type of function is represented by the graph shown below?

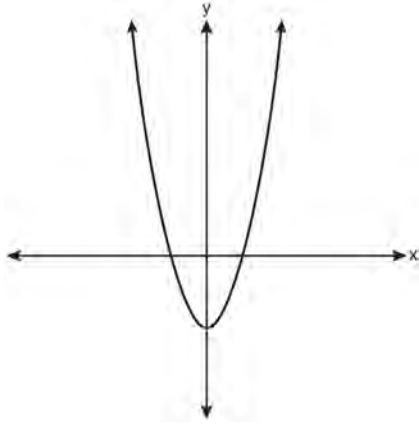

- 1) absolute value
2) exponential
3) linear
4) quadratic
- 119 Which interval notation represents the set of all numbers greater than or equal to 5 and less than 12?
- 1) $[5, 12)$
2) $(5, 12]$
3) $(5, 12)$
4) $[5, 12]$
- 120 A right triangle contains a 38° angle whose adjacent side measures 10 centimeters. What is the length of the hypotenuse, to the *nearest hundredth of a centimeter*?
- 1) 7.88
2) 12.69
3) 12.80
4) 16.24

- 121 Which point lies on the line whose equation is $2x - 3y = 9$?

- 1) $(-1, -3)$
2) $(-1, 3)$
3) $(0, 3)$
4) $(0, -3)$

- 122 Which set of ordered pairs represents a function?

- 1) $\{(0, 4), (2, 4), (2, 5)\}$
2) $\{(6, 0), (5, 0), (4, 0)\}$
3) $\{(4, 1), (6, 2), (6, 3), (5, 0)\}$
4) $\{(0, 4), (1, 4), (0, 5), (1, 5)\}$

- 123 The spinner shown in the diagram below is divided into six equal sections.

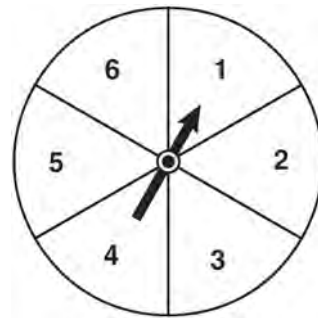

Which outcome is *least* likely to occur on a single spin?

- 1) an odd number
2) a prime number
3) a perfect square
4) a number divisible by 2

Integrated Algebra Multiple Choice Regents Exam Questions

www.jmap.org

124 What is the value of the y-coordinate of the solution to the system of equations $2x + y = 8$ and $x - 3y = -3$?

- 1) -2
- 2) 2
- 3) 3
- 4) -3

125 Which equation has roots of -3 and 5?

- 1) $x^2 + 2x - 15 = 0$
- 2) $x^2 - 2x - 15 = 0$
- 3) $x^2 + 2x + 15 = 0$
- 4) $x^2 - 2x + 15 = 0$

126 Which expression represents $\frac{-14a^2c^8}{7a^3c^2}$ in simplest form?

- 1) $-2ac^4$
- 2) $-2ac^6$
- 3) $\frac{-2c^4}{a}$
- 4) $\frac{-2c^6}{a}$

127 Which algebraic expression represents 15 less than x divided by 9?

- 1) $\frac{x}{9} - 15$
- 2) $9x - 15$
- 3) $15 - \frac{x}{9}$
- 4) $15 - 9x$

128 Which graph represents an exponential equation?

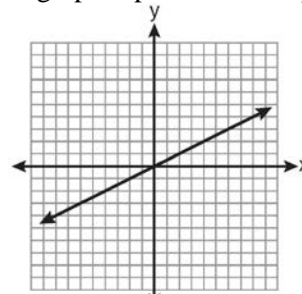

1)

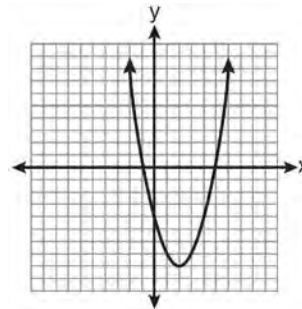

2)

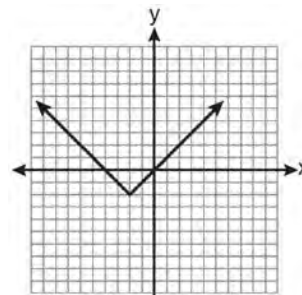

3)

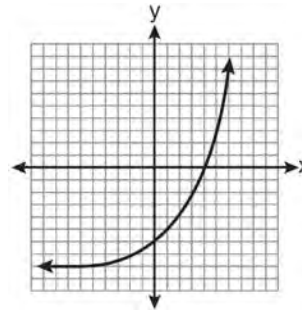

4)

Integrated Algebra Multiple Choice Regents Exam Questions

www.jmap.org

- 129 A survey is being conducted to determine which school board candidate would best serve the Yonkers community. Which group, when randomly surveyed, would likely produce the most bias?
- 1) 15 employees of the Yonkers school district
 - 2) 25 people driving past Yonkers High School
 - 3) 75 people who enter a Yonkers grocery store
 - 4) 100 people who visit the local Yonkers shopping mall
- 130 What is an equation of the axis of symmetry of the parabola represented by $y = -x^2 + 6x - 4$?
- 1) $x = 3$
 - 2) $y = 3$
 - 3) $x = 6$
 - 4) $y = 6$
- 131 The expression $6\sqrt{50} + 6\sqrt{2}$ written in simplest radical form is
- 1) $6\sqrt{52}$
 - 2) $12\sqrt{52}$
 - 3) $17\sqrt{2}$
 - 4) $36\sqrt{2}$
- 132 Which equation represents the line that passes through the point (1,5) and has a slope of -2 ?
- 1) $y = -2x + 7$
 - 2) $y = -2x + 11$
 - 3) $y = 2x - 9$
 - 4) $y = 2x + 3$
- 133 What is the sum of $\frac{3}{2x}$ and $\frac{7}{4x}$?
- 1) $\frac{21}{8x^2}$
 - 2) $\frac{13}{4x}$
 - 3) $\frac{10}{6x}$
 - 4) $\frac{13}{8x}$
- 134 The value of a car purchased for \$20,000 decreases at a rate of 12% per year. What will be the value of the car after 3 years?
- 1) \$12,800.00
 - 2) \$13,629.44
 - 3) \$17,600.00
 - 4) \$28,098.56
- 135 The expression $x^2 - 36y^2$ is equivalent to
- 1) $(x - 6y)(x - 6y)$
 - 2) $(x - 18y)(x - 18y)$
 - 3) $(x + 6y)(x - 6y)$
 - 4) $(x + 18y)(x - 18y)$
- 136 What is the perimeter of a regular pentagon with a side whose length is $x + 4$?
- 1) $x^2 + 16$
 - 2) $4x + 16$
 - 3) $5x + 4$
 - 4) $5x + 20$

Integrated Algebra Multiple Choice Regents Exam Questions

www.jmap.org

137 Which data table represents univariate data?

1)

Side Length of a Square	Area of Square
2	4
3	9
4	16
5	25

2)

Hours Worked	Pay
20	\$160
25	\$200
30	\$240
35	\$280

3)

Age Group	Frequency
20–29	9
30–39	7
40–49	10
50–59	4

4)

People	Number of Fingers
2	20
3	30
4	40
5	50

138 Which equation represents a line parallel to the y-axis?

- 1) $y = x$
- 2) $y = 3$
- 3) $x = -y$
- 4) $x = -4$

139 Which expression represents $\frac{x^2 - x - 6}{x^2 - 5x + 6}$ in simplest form?

- 1) $\frac{x+2}{x-2}$
- 2) $\frac{-x-6}{-5x+6}$
- 3) $\frac{1}{5}$
- 4) -1

140 What are the vertex and axis of symmetry of the parabola shown in the diagram below?

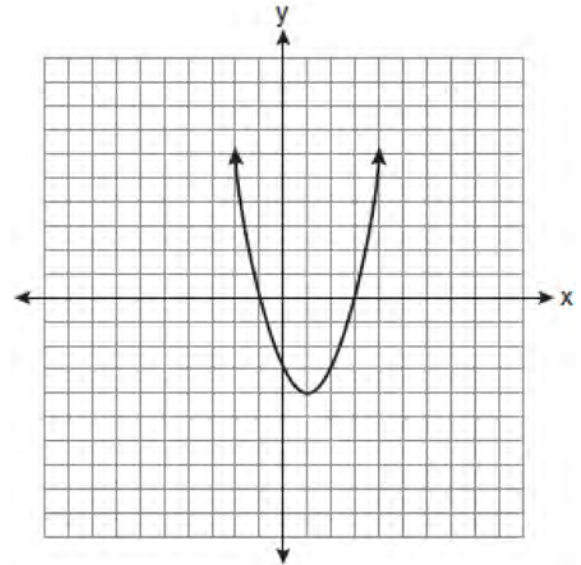

- 1) vertex: (1, -4); axis of symmetry: $x = 1$
- 2) vertex: (1, -4); axis of symmetry: $x = -4$
- 3) vertex: (-4, 1); axis of symmetry: $x = 1$
- 4) vertex: (-4, 1); axis of symmetry: $x = -4$

Integrated Algebra Multiple Choice Regents Exam Questions

www.jmap.org

- 141 The value of the expression $-|a - b|$ when $a = 7$ and $b = -3$ is
- 1) -10
 - 2) 10
 - 3) -4
 - 4) 4

- 142 For which set of values of x is the algebraic expression $\frac{x^2 - 16}{x^2 - 4x - 12}$ undefined?
- 1) $\{-6, 2\}$
 - 2) $\{-4, 3\}$
 - 3) $\{-4, 4\}$
 - 4) $\{-2, 6\}$

- 143 The end of a dog's leash is attached to the top of a 5-foot-tall fence post, as shown in the diagram below. The dog is 7 feet away from the base of the fence post.

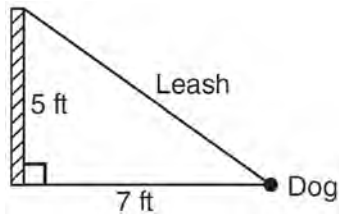

How long is the leash, to the *nearest tenth of a foot*?

- 1) 4.9
- 2) 8.6
- 3) 9.0
- 4) 12.0

- 144 Which graph can be used to find the solution of the following system of equations?

$$y = x^2 + 2x + 3$$

$$2y - 2x = 10$$

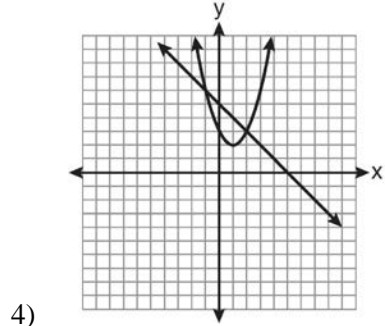
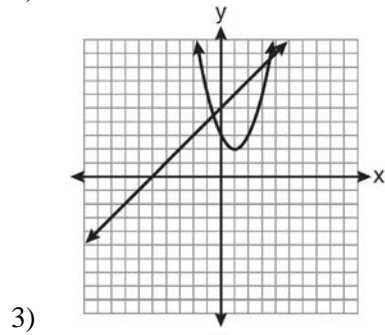
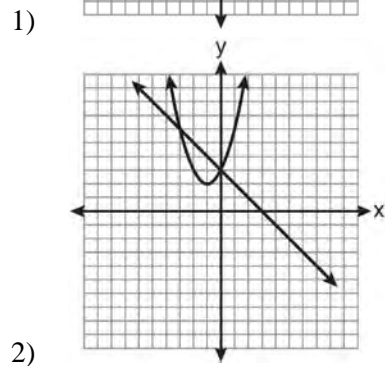
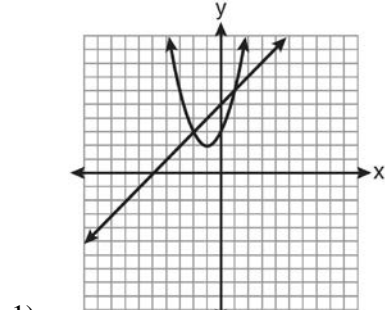

Integrated Algebra Multiple Choice Regents Exam Questions

www.jmap.org

- 145 The probability that it will snow on Sunday is $\frac{3}{5}$.
The probability that it will snow on both Sunday and Monday is $\frac{3}{10}$. What is the probability that it will snow on Monday, if it snowed on Sunday?
- 1) $\frac{9}{50}$
 - 2) 2
 - 3) $\frac{1}{2}$
 - 4) $\frac{9}{10}$
- 146 When 36 is subtracted from the square of a number, the result is five times the number. What is the positive solution?
- 1) 9
 - 2) 6
 - 3) 3
 - 4) 4
- 147 How many different three-letter arrangements can be formed using the letters in the word *ABSOLUTE* if each letter is used only once?
- 1) 56
 - 2) 112
 - 3) 168
 - 4) 336
- 148 The length of a rectangle is 3 inches more than its width. The area of the rectangle is 40 square inches. What is the length, in inches, of the rectangle?
- 1) 5
 - 2) 8
 - 3) 8.5
 - 4) 11.5
- 149 Given: Set $U = \{S, O, P, H, I, A\}$
Set $B = \{A, I, O\}$
If set B is a subset of set U , what is the complement of set B ?
- 1) $\{O, P, S\}$
 - 2) $\{I, P, S\}$
 - 3) $\{A, H, P\}$
 - 4) $\{H, P, S\}$
- 150 Which set-builder notation describes $\{-3, -2, -1, 0, 1, 2\}$?
- 1) $\{x \mid -3 \leq x < 2, \text{ where } x \text{ is an integer}\}$
 - 2) $\{x \mid -3 < x \leq 2, \text{ where } x \text{ is an integer}\}$
 - 3) $\{x \mid -3 < x < 2, \text{ where } x \text{ is an integer}\}$
 - 4) $\{x \mid -3 \leq x \leq 2, \text{ where } x \text{ is an integer}\}$
- 151 Melissa graphed the equation $y = x^2$ and Dave graphed the equation $y = -3x^2$ on the same coordinate grid. What is the relationship between the graphs that Melissa and Dave drew?
- 1) Dave's graph is wider and opens in the opposite direction from Melissa's graph.
 - 2) Dave's graph is narrower and opens in the opposite direction from Melissa's graph.
 - 3) Dave's graph is wider and is three units below Melissa's graph.
 - 4) Dave's graph is narrower and is three units to the left of Melissa's graph.
- 152 Which verbal expression can be represented by $2(x - 5)$?
- 1) 5 less than 2 times x
 - 2) 2 multiplied by x less than 5
 - 3) twice the difference of x and 5
 - 4) the product of 2 and x , decreased by 5

Integrated Algebra Multiple Choice Regents Exam Questions

www.jmap.org

- 153 This year, John played in 10 baseball games. In these games he had hit the ball 2, 3, 0, 1, 3, 2, 4, 0, 2, and 3 times. In the first 10 games he plays next year, John wants to increase his average (mean) hits per game by 0.5. What is the total number of hits John needs over the first 10 games next year to achieve his goal?
- 1) 5
 - 2) 2
 - 3) 20
 - 4) 25

- 154 Which point is on the line $4y - 2x = 0$?
- 1) $(-2, -1)$
 - 2) $(-2, 1)$
 - 3) $(-1, -2)$
 - 4) $(1, 2)$

- 155 An example of an algebraic expression is
- 1) $\frac{2x+3}{7} = \frac{13}{x}$
 - 2) $(2x+1)(x-7)$
 - 3) $4x - 1 = 4$
 - 4) $x = 2$

- 156 Given: $A = \{3, 6, 9, 12, 15\}$
 $B = \{2, 4, 6, 8, 10, 12\}$
 What is the union of sets A and B ?
- 1) $\{6\}$
 - 2) $\{6, 12\}$
 - 3) $\{2, 3, 4, 8, 9, 10, 15\}$
 - 4) $\{2, 3, 4, 6, 8, 9, 10, 12, 15\}$

- 157 Which scatter plot shows the relationship between x and y if x represents a student score on a test and y represents the number of incorrect answers a student received on the same test?

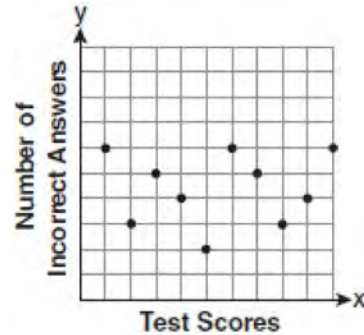

1)

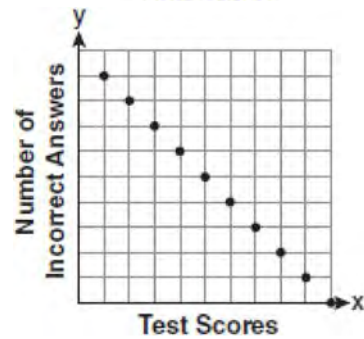

2)

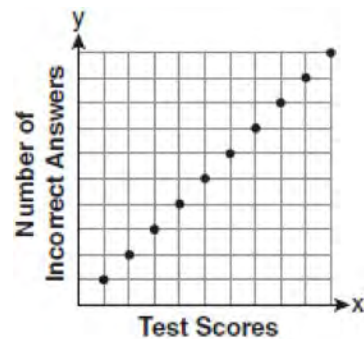

3)

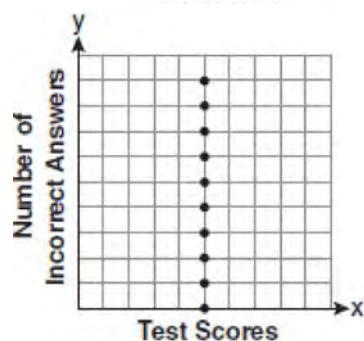

4)

Integrated Algebra Multiple Choice Regents Exam Questions

www.jmap.org

- 158 A figure is made up of a rectangle and a semicircle as shown in the diagram below.

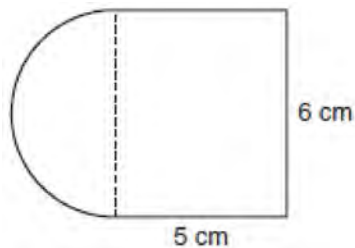

What is the area of the figure, to the *nearest tenth* of a square centimeter?

- 1) 39.4
 2) 44.1
 3) 48.8
 4) 58.3
- 159 How many different four-letter arrangements are possible with the letters G, A, R, D, E, N if each letter may be used only once?
- 1) 15
 2) 24
 3) 360
 4) 720
- 160 What is the solution of the system of equations $2x - 5y = 11$ and $-2x + 3y = -9$?
- 1) $(-3, -1)$
 2) $(-1, 3)$
 3) $(3, -1)$
 4) $(3, 1)$

- 161 Which equation represents a quadratic function?
- 1) $y = x + 2$
 2) $y = |x + 2|$
 3) $y = x^2$
 4) $y = 2^x$

- 162 What is the solution of the system of equations $c + 3d = 8$ and $c = 4d - 6$?
- 1) $c = -14, d = -2$
 2) $c = -2, d = 2$
 3) $c = 2, d = 2$
 4) $c = 14, d = -2$

- 163 Maria has a set of 10 index cards labeled with the digits 0 through 9. She puts them in a bag and selects one at random. The outcome that is most likely to occur is selecting
- 1) an odd number
 2) a prime number
 3) a number that is at most 5
 4) a number that is divisible by 3

- 164 In interval notation, the set of all real numbers greater than -6 and less than or equal to 14 is represented by
- 1) $(-6, 14)$
 2) $[-6, 14)$
 3) $(-6, 14]$
 4) $[-6, 14]$

Integrated Algebra Multiple Choice Regents Exam Questions

www.jmap.org

- 165 In the diagram below, $MATH$ is a rectangle, $GB = 4.6$, $MH = 6$, and $HT = 15$.

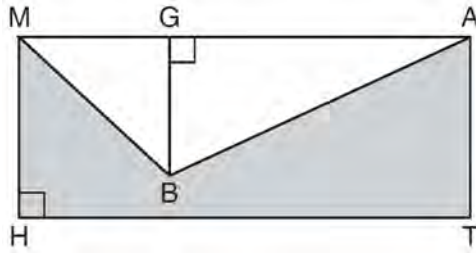

What is the area of polygon $MBATH$?

- 1) 34.5
 - 2) 55.5
 - 3) 90.0
 - 4) 124.5
- 166 What is the solution set of $\frac{x+2}{x-2} = \frac{-3}{x}$?

- 1) $\{-2, 3\}$
- 2) $\{-3, -2\}$
- 3) $\{-1, 6\}$
- 4) $\{-6, 1\}$

- 167 If $\frac{ey}{n} + k = t$, what is y in terms of e , n , k , and t ?

- 1) $y = \frac{tn+k}{e}$
- 2) $y = \frac{tn-k}{e}$
- 3) $y = \frac{n(t+k)}{e}$
- 4) $y = \frac{n(t-k)}{e}$

- 168 Which value of x is the solution of $\frac{2x-3}{x-4} = \frac{2}{3}$?

- 1) $-\frac{1}{4}$
- 2) $\frac{1}{4}$
- 3) -4
- 4) 4

- 169 Which value of x is the solution of the equation

$$\frac{2}{3}x + \frac{1}{2} = \frac{5}{6}?$$

- 1) $\frac{1}{2}$
- 2) 2
- 3) $\frac{2}{3}$
- 4) $\frac{3}{2}$

- 170 Which data set describes a situation that could be classified as quantitative?

- 1) the phone numbers in a telephone book
- 2) the addresses for students at Hopkins High School
- 3) the zip codes of residents in the city of Buffalo, New York
- 4) the time it takes each of Mr. Harper's students to complete a test

- 171 What is $3\sqrt{2} + \sqrt{8}$ expressed in simplest radical form?

- 1) $3\sqrt{10}$
- 2) $3\sqrt{16}$
- 3) $5\sqrt{2}$
- 4) $7\sqrt{2}$

Integrated Algebra Multiple Choice Regents Exam Questions

www.jmap.org

172 Which equation represents a line parallel to the y -axis?

- 1) $x = y$
- 2) $x = 4$
- 3) $y = 4$
- 4) $y = x + 4$

173 When $a^3 - 4a$ is factored completely, the result is

- 1) $(a - 2)(a + 2)$
- 2) $a(a - 2)(a + 2)$
- 3) $a^2(a - 4)$
- 4) $a(a - 2)^2$

174 The members of the senior class are planning a dance. They use the equation $r = pn$ to determine the total receipts. What is n expressed in terms of r and p ?

- 1) $n = r + p$
- 2) $n = r - p$
- 3) $n = \frac{p}{r}$
- 4) $n = \frac{r}{p}$

175 Which expression represents $36x^2 - 100y^6$ factored completely?

- 1) $2(9x + 25y^3)(9x - 25y^3)$
- 2) $4(3x + 5y^3)(3x - 5y^3)$
- 3) $(6x + 10y^3)(6x - 10y^3)$
- 4) $(18x + 50y^3)(18x - 50y^3)$

176 In the diagram below, what is the slope of the line passing through points A and B ?

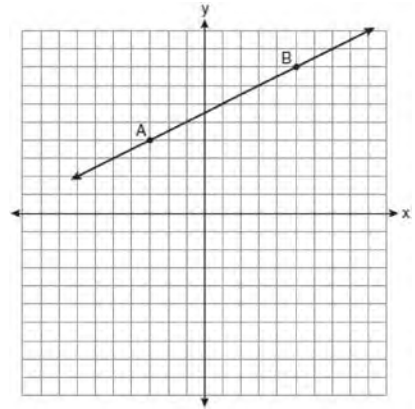

- 1) -2
- 2) 2
- 3) $-\frac{1}{2}$
- 4) $\frac{1}{2}$

177 Right triangle ABC has legs of 8 and 15 and a hypotenuse of 17, as shown in the diagram below.

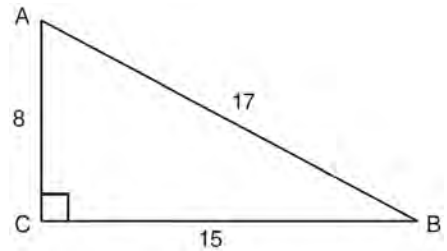

The value of the tangent of $\angle B$ is

- 1) 0.4706
- 2) 0.5333
- 3) 0.8824
- 4) 1.8750

Integrated Algebra Multiple Choice Regents Exam Questions

- 178 The actual dimensions of a rectangle are 2.6 cm by 6.9 cm. Andy measures the sides as 2.5 cm by 6.8 cm. In calculating the area, what is the relative error, to the nearest thousandth?
- 1) 0.055
 - 2) 0.052
 - 3) 0.022
 - 4) 0.021

- 182 If $s = \frac{2x+t}{r}$, then x equals
- 1) $\frac{rs-t}{2}$
 - 2) $\frac{rs+1}{2}$
 - 3) $2rs-t$
 - 4) $rs-2t$

- 179 Which expression is equivalent to $64 - x^2$?
- 1) $(8-x)(8-x)$
 - 2) $(8-x)(8+x)$
 - 3) $(x-8)(x-8)$
 - 4) $(x-8)(x+8)$

- 183 Which equation is an example of the use of the associative property of addition?
- 1) $x+7=7+x$
 - 2) $3(x+y)=3x+3y$
 - 3) $(x+y)+3=x+(y+3)$
 - 4) $3+(x+y)=(x+y)+3$

- 180 Given: $A = \{2,4,5,7,8\}$
 $B = \{3,5,8,9\}$
 What is $A \cup B$?
- 1) $\{5\}$
 - 2) $\{5,8\}$
 - 3) $\{2,3,4,7,9\}$
 - 4) $\{2,3,4,5,7,8,9\}$

- 184 The scatter plot below shows the profit, by month, for a new company for the first year of operation. Kate drew a line of best fit, as shown in the diagram.

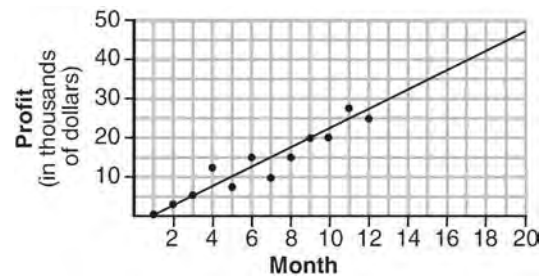

- 181 The value of y in the equation $0.06y + 200 = 0.03y + 350$ is
- 1) 500
 - 2) $1,666.\bar{6}$
 - 3) 5,000
 - 4) $18,333.\bar{3}$

- Using this line, what is the best estimate for profit in the 18th month?
- 1) \$35,000
 - 2) \$37,750
 - 3) \$42,500
 - 4) \$45,000

Integrated Algebra Multiple Choice Regents Exam Questions

www.jmap.org

- 185 Craig sees an advertisement for a car in a newspaper. Which information would *not* be classified as quantitative?
- 1) the cost of the car
 - 2) the car's mileage
 - 3) the model of the car
 - 4) the weight of the car
- 186 The length of one side of a square is 13 feet. What is the length, to the *nearest foot*, of a diagonal of the square?
- 1) 13
 - 2) 18
 - 3) 19
 - 4) 26
- 187 Which equation represents a line that has a slope of $\frac{3}{4}$ and passes through the point (2, 1)?
- 1) $3y = 4x - 5$
 - 2) $3y = 4x + 2$
 - 3) $4y = 3x - 2$
 - 4) $4y = 3x + 5$
- 188 In a baseball game, the ball traveled 350.7 feet in 4.2 seconds. What was the average speed of the ball, in feet per second?
- 1) 83.5
 - 2) 177.5
 - 3) 354.9
 - 4) 1,472.9
- 189 If $A = \{0, 1, 3, 4, 6, 7\}$, $B = \{0, 2, 3, 5, 6\}$, and $C = \{0, 1, 4, 6, 7\}$, then $A \cap B \cap C$ is
- 1) $\{0, 1, 2, 3, 4, 5, 6, 7\}$
 - 2) $\{0, 3, 6\}$
 - 3) $\{0, 6\}$
 - 4) $\{0\}$
- 190 Which situation is an example of bivariate data?
- 1) the number of pizzas Tanya eats during her years in high school
 - 2) the number of times Ezra puts air, in his bicycle tires during the summer
 - 3) the number of home runs Elias hits per game and the number of hours he practices baseball
 - 4) the number of hours Nellie studies for her mathematics tests during the first half of the school year
- 191 The sum of $3x^2 + 5x - 6$ and $-x^2 + 3x + 9$ is
- 1) $2x^2 + 8x - 15$
 - 2) $2x^2 + 8x + 3$
 - 3) $2x^4 + 8x^2 + 3$
 - 4) $4x^2 + 2x - 15$
- 192 The expression $9a^2 - 64b^2$ is equivalent to
- 1) $(9a - 8b)(a + 8b)$
 - 2) $(9a - 8b)(a - 8b)$
 - 3) $(3a - 8b)(3a + 8b)$
 - 4) $(3a - 8b)(3a - 8b)$

Integrated Algebra Multiple Choice Regents Exam Questions

www.jmap.org

- 193 The roots of the equation $3x^2 - 27x = 0$ are
- 1) 0 and 9
 - 2) 0 and -9
 - 3) 0 and 3
 - 4) 0 and -3

- 194 A cell phone can receive 120 messages per minute. At this rate, how many messages can the phone receive in 150 seconds?
- 1) 48
 - 2) 75
 - 3) 300
 - 4) 18,000

- 195 Peter walked 8,900 feet from home to school.

1 mile = 5,280 feet

How far, to the *nearest tenth of a mile*, did he walk?

- 1) 0.5
 - 2) 0.6
 - 3) 1.6
 - 4) 1.7
- 196 The length of a rectangle is 15 and its width is w . The perimeter of the rectangle is, *at most*, 50. Which inequality can be used to find the longest possible width?
- 1) $30 + 2w < 50$
 - 2) $30 + 2w \leq 50$
 - 3) $30 + 2w > 50$
 - 4) $30 + 2w \geq 50$

- 197 The probability it will rain tomorrow is $\frac{1}{2}$. The probability that our team will win tomorrow's basketball game is $\frac{3}{5}$. Which expression represents the probability that it will rain and that our team will *not* win the game?

- 1) $\frac{1}{2} + \frac{3}{5}$
- 2) $\frac{1}{2} + \frac{2}{5}$
- 3) $\frac{1}{2} \times \frac{3}{5}$
- 4) $\frac{1}{2} \times \frac{2}{5}$

- 198 What are the coordinates of the vertex and the equation of the axis of symmetry of the parabola shown in the graph below?

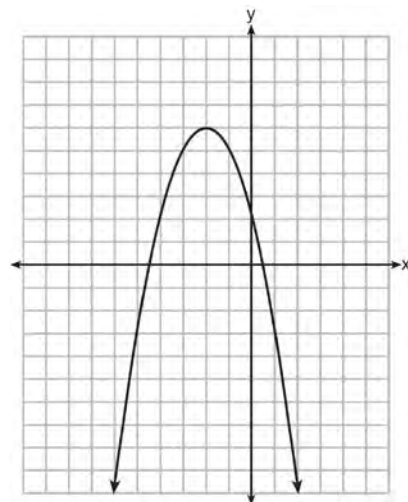

- 1) $(0, 2)$ and $y = 2$
- 2) $(0, 2)$ and $x = 2$
- 3) $(-2, 6)$ and $y = -2$
- 4) $(-2, 6)$ and $x = -2$

Integrated Algebra Multiple Choice Regents Exam Questions

www.jmap.org

- 199 Mr. Stanton asked his students to write an algebraic expression on a piece of paper. He chose four students to go to the board and write their expression.

Robert wrote: $4(2x + 5) \geq 17$

Meredith wrote: $3y - 7 + 11z$

Steven wrote: $9w + 2 = 20$

Cynthia wrote: $8 + 10 - 4 = 14$

Which student wrote an algebraic expression?

- 1) Robert
 - 2) Meredith
 - 3) Steven
 - 4) Cynthia
- 200 Marcy determined that her father's age is four less than three times her age. If x represents Marcy's age, which expression represents her father's age?
- 1) $3x - 4$
 - 2) $3(x - 4)$
 - 3) $4x - 3$
 - 4) $4 - 3x$

- 201 What is the sum of $-3x^2 - 7x + 9$ and $-5x^2 + 6x - 4$?
- 1) $-8x^2 - x + 5$
 - 2) $-8x^4 - x + 5$
 - 3) $-8x^2 - 13x + 13$
 - 4) $-8x^4 - 13x^2 + 13$

- 202 What is the solution set of the system of equations $x + y = 5$ and $y = x^2 - 25$?
- 1) $\{(0, 5), (11, -6)\}$
 - 2) $\{(5, 0), (-6, 11)\}$
 - 3) $\{(-5, 0), (6, 11)\}$
 - 4) $\{(-5, 10), (6, -1)\}$

- 203 The rectangular prism shown below has a length of 3.0 cm, a width of 2.2 cm, and a height of 7.5 cm.

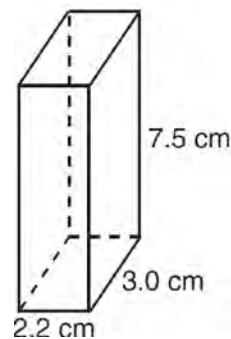

What is the surface area, in square centimeters?

- 1) 45.6
 - 2) 49.5
 - 3) 78.0
 - 4) 91.2
- 204 A correct translation of "six less than twice the value of x " is
- 1) $2x < 6$
 - 2) $2x - 6$
 - 3) $6 < 2x$
 - 4) $6 - 2x$
- 205 Which interval notation describes the set $S = \{x \mid 1 \leq x < 10\}$?
- 1) $[1, 10]$
 - 2) $(1, 10]$
 - 3) $[1, 10)$
 - 4) $(1, 10)$

Integrated Algebra Multiple Choice Regents Exam Questions

www.jmap.org

206 Which graph represents a function?

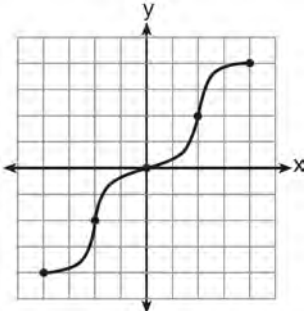

1)

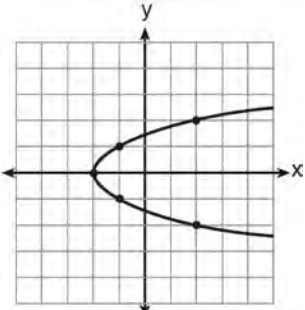

2)

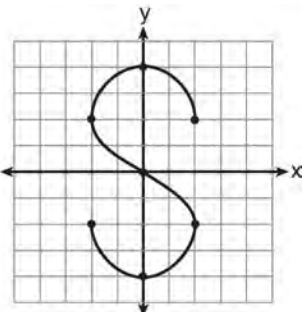

3)

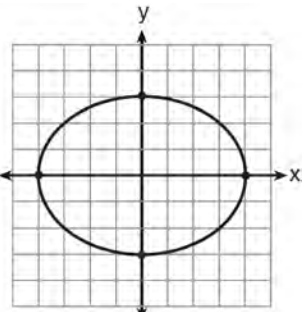

4)

207 Is the equation $A = 21000(1 - 0.12)^t$ a model of exponential growth or exponential decay, and what is the rate (percent) of change per time period?

- 1) exponential growth and 12%
- 2) exponential growth and 88%
- 3) exponential decay and 12%
- 4) exponential decay and 88%

208 The line represented by the equation $2y - 3x = 4$ has a slope of

- 1) $-\frac{3}{2}$
- 2) 2
- 3) 3
- 4) $\frac{3}{2}$

209 Which expression represents $\frac{x^2 - 3x - 10}{x^2 - 25}$ in simplest form?

- 1) $\frac{2}{5}$
- 2) $\frac{x+2}{x+5}$
- 3) $\frac{x-2}{x-5}$
- 4) $\frac{-3x-10}{-25}$

210 For which values of x is the fraction $\frac{x^2 + x - 6}{x^2 + 5x - 6}$ undefined?

- 1) 1 and -6
- 2) 2 and -3
- 3) 3 and -2
- 4) 6 and -1

Integrated Algebra Multiple Choice Regents Exam Questions

www.jmap.org

211 The expression $\frac{14+x}{x^2-4}$ is undefined when x is

- 1) -14, only
- 2) 2, only
- 3) -2 or 2
- 4) -14, -2, or 2

212 Factored completely, the expression

$3x^3 - 33x^2 + 90x$ is equivalent to

- 1) $3x(x^2 - 33x + 90)$
- 2) $3x(x^2 - 11x + 30)$
- 3) $3x(x+5)(x+6)$
- 4) $3x(x-5)(x-6)$

213 What is the slope of the line that passes through the points $(2, -3)$ and $(5, 1)$?

- 1) $-\frac{2}{3}$
- 2) $\frac{2}{3}$
- 3) $-\frac{4}{3}$
- 4) $\frac{4}{3}$

214 Which statement illustrates the additive identity property?

- 1) $6 + 0 = 6$
- 2) $-6 + 6 = 0$
- 3) $4(6 + 3) = 4(6) + 4(3)$
- 4) $(4 + 6) + 3 = 4 + (6 + 3)$

215 The diagram below shows right triangle LMP .

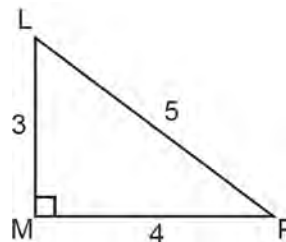

Which ratio represents the tangent of $\angle PLM$?

- 1) $\frac{3}{4}$
- 2) $\frac{3}{5}$
- 3) $\frac{4}{3}$
- 4) $\frac{5}{4}$

216 Three fair coins are tossed. What is the probability that two heads and one tail appear?

- 1) $\frac{1}{8}$
- 2) $\frac{3}{8}$
- 3) $\frac{3}{6}$
- 4) $\frac{2}{3}$

217 If five times a number is less than 55, what is the greatest possible integer value of the number?

- 1) 12
- 2) 11
- 3) 10
- 4) 9

Integrated Algebra Multiple Choice Regents Exam Questions

www.jmap.org

218 A set of data is graphed on the scatter plot below.

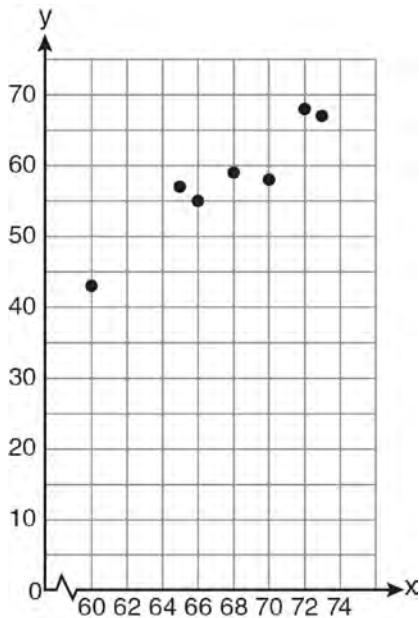

This scatter plot shows

- 1) no correlation
- 2) positive correlation
- 3) negative correlation
- 4) undefined correlation

219 The equation of the axis of symmetry of the graph of $y = 2x^2 - 3x + 7$ is

- 1) $x = \frac{3}{4}$
- 2) $y = \frac{3}{4}$
- 3) $x = \frac{3}{2}$
- 4) $y = \frac{3}{2}$

220 If n is an odd integer, which equation can be used to find three consecutive odd integers whose sum is -3 ?

- 1) $n + (n + 1) + (n + 3) = -3$
- 2) $n + (n + 1) + (n + 2) = -3$
- 3) $n + (n + 2) + (n + 4) = -3$
- 4) $n + (n + 2) + (n + 3) = -3$

221 What is the sum of $\frac{2y}{y+5}$ and $\frac{10}{y+5}$ expressed in simplest form?

- 1) 1
- 2) 2
- 3) $\frac{12y}{y+5}$
- 4) $\frac{2y+10}{y+5}$

222 A survey is being conducted to determine if a cable company should add another sports channel to their schedule. Which random survey would be the least biased?

- 1) surveying 30 men at a gym
- 2) surveying 45 people at a mall
- 3) surveying 50 fans at a football game
- 4) surveying 20 members of a high school soccer team

223 Brianna's score on a national math assessment exceeded the scores of 95,000 of the 125,000 students who took the assessment. What was her percentile rank?

- 1) 6
- 2) 24
- 3) 31
- 4) 76

Integrated Algebra Multiple Choice Regents Exam Questions

www.jmap.org

- 224 In the diagram below, circle O is inscribed in square $ABCD$. The square has an area of 36.

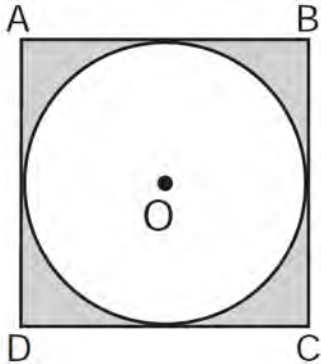

What is the area of the circle?

- 1) 9?
 2) 6?
 3) 3?
 4) 36?
- 225 What is the solution of $\frac{2}{x+1} = \frac{x+1}{2}$?
- 1) -1 and -3
 2) -1 and 3
 3) 1 and -3
 4) 1 and 3
- 226 If $k = am + 3mx$, the value of m in terms of a , k , and x can be expressed as
- 1) $\frac{k}{a + 3x}$
 2) $\frac{k - 3mx}{a}$
 3) $\frac{k - am}{3x}$
 4) $\frac{k - a}{3x}$

- 227 Which graph does *not* represent a function?

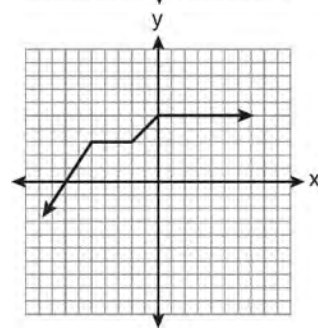
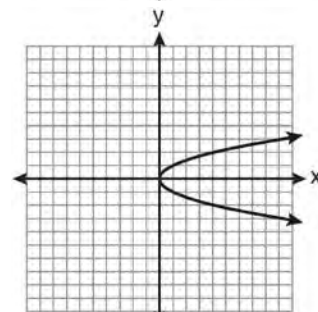
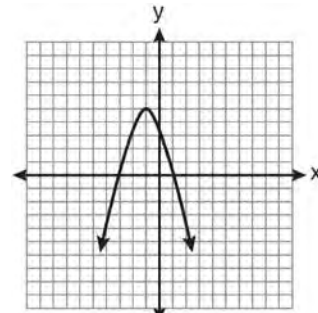
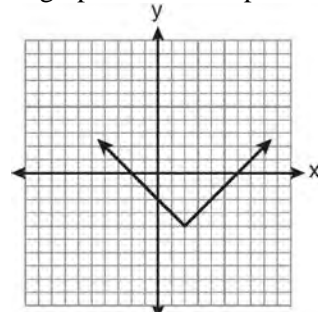

Integrated Algebra Multiple Choice Regents Exam Questions

www.jmap.org

- 228 Elizabeth is baking chocolate chip cookies. A single batch uses $\frac{3}{4}$ teaspoon of vanilla. If Elizabeth is mixing the ingredients for five batches at the same time, how many tablespoons of vanilla will she use?

$3 \text{ teaspoons} = 1 \text{ tablespoon}$
--

- 1) $1\frac{1}{4}$
 2) $1\frac{3}{4}$
 3) $3\frac{3}{4}$
 4) $5\frac{3}{4}$
- 229 What is the product of $(3x + 2)$ and $(x - 7)$?
- 1) $3x^2 - 14$
 2) $3x^2 - 5x - 14$
 3) $3x^2 - 19x - 14$
 4) $3x^2 - 23x - 14$

- 230 The quotient of $\frac{8x^5 - 2x^4 + 4x^3 - 6x^2}{2x^2}$ is
- 1) $16x^7 - 4x^6 + 8x^5 - 12x^4$
 2) $4x^7 - x^6 + 2x^5 - 3x^4$
 3) $4x^3 - x^2 + 2x - 3x$
 4) $4x^3 - x^2 + 2x - 3$

- 231 The expression $\frac{(4x^3)^2}{2x}$ is equivalent to
- 1) $4x^4$
 2) $4x^5$
 3) $8x^4$
 4) $8x^5$

- 232 What is one-third of 3^6 ?
- 1) 1^2
 2) 3^2
 3) 3^5
 4) 9^6

- 233 The cumulative frequency table below shows the length of time that 30 students spent text messaging on a weekend.

Minutes Used	Cumulative Frequency
31-40	2
31-50	5
31-60	10
31-70	19
31-80	30

- Which 10-minute interval contains the first quartile?
- 1) 31 - 40
 2) 41 - 50
 3) 51 - 60
 4) 61 - 70

Integrated Algebra Multiple Choice Regents Exam Questions

www.jmap.org

234 Which equation is represented by the graph below?

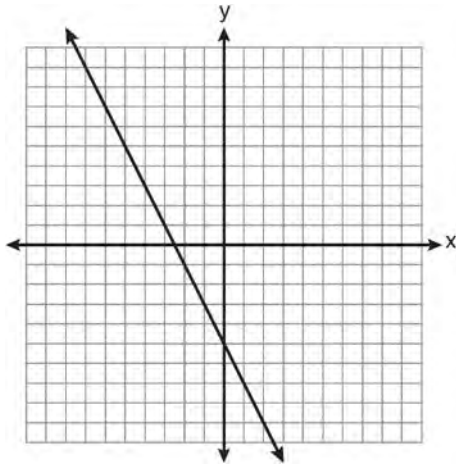

- 1) $2y + x = 10$
- 2) $y - 2x = -5$
- 3) $-2y = 10x - 4$
- 4) $2y = -4x - 10$

235 If the universal set is {pennies, nickels, dimes, quarters}, what is the complement of the set {nickels}?

- 1) { }
- 2) {pennies, quarters}
- 3) {pennies, dimes, quarters}
- 4) {pennies, nickels, dimes, quarters}

236 In $\triangle ABC$, $m\angle C = 90$. If $AB = 5$ and $AC = 4$, which statement is *not* true?

- 1) $\cos A = \frac{4}{5}$
- 2) $\tan A = \frac{3}{4}$
- 3) $\sin B = \frac{4}{5}$
- 4) $\tan B = \frac{5}{3}$

237 Two equations were graphed on the set of axes below.

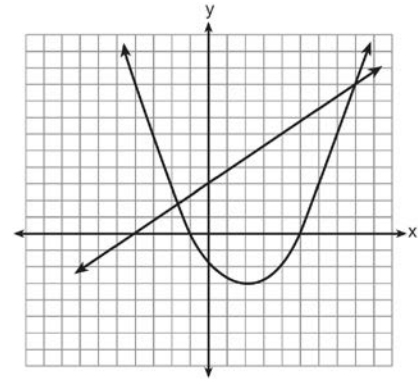

Which point is a solution of the system of equations shown on the graph?

- 1) (8,9)
- 2) (5,0)
- 3) (0,3)
- 4) (2,-3)

238 The scatter plot shown below represents a relationship between x and y .

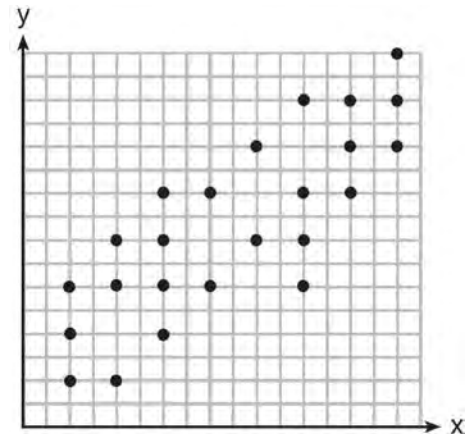

This type of relationship is

- 1) a positive correlation
- 2) a negative correlation
- 3) a zero correlation
- 4) not able to be determined

Integrated Algebra Multiple Choice Regents Exam Questions

www.jmap.org

239 A car depreciates (loses value) at a rate of 4.5% annually. Greg purchased a car for \$12,500. Which equation can be used to determine the value of the car, V , after 5 years?

- 1) $V = 12,500(0.55)^5$
- 2) $V = 12,500(0.955)^5$
- 3) $V = 12,500(1.045)^5$
- 4) $V = 12,500(1.45)^5$

240 Which coordinates represent a point in the solution set of the system of inequalities shown below?

$$y \leq \frac{1}{2}x + 13$$

$$4x + 2y > 3$$

- 1) $(-4, 1)$
- 2) $(-2, 2)$
- 3) $(1, -4)$
- 4) $(2, -2)$

241 The graph of $y = |x + 2|$ is shown below.

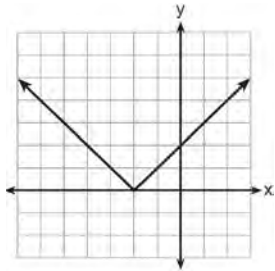

Which graph represents $y = -|x + 2|$?

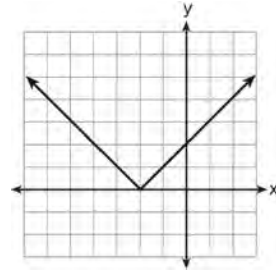

1)

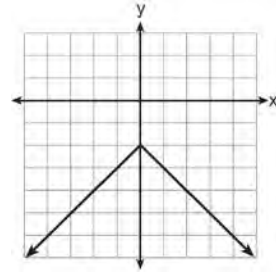

2)

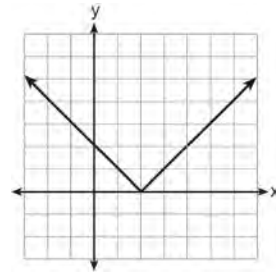

3)

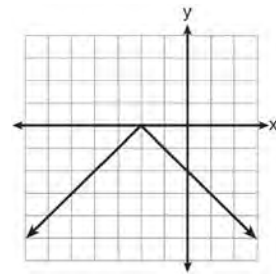

4)

242 The quotient of (9.2×10^6) and (2.3×10^2) expressed in scientific notation is

- 1) 4,000
- 2) 40,000
- 3) 4×10^3
- 4) 4×10^4

Integrated Algebra Multiple Choice Regents Exam Questions

www.jmap.org

243 What is the value of $\left| \frac{4(-6) + 18}{4!} \right|$?

- 1) $\frac{1}{4}$
- 2) $-\frac{1}{4}$
- 3) 12
- 4) -12

244 What are the vertex and the axis of symmetry of the parabola shown in the graph below?

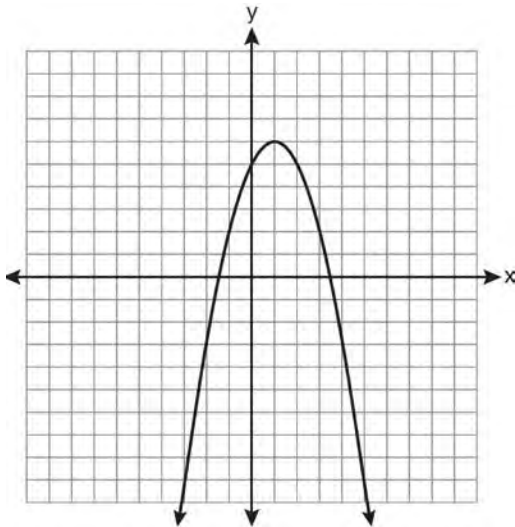

- 1) vertex: (1,6); axis of symmetry: $y = 1$
- 2) vertex: (1,6); axis of symmetry: $x = 1$
- 3) vertex: (6,1); axis of symmetry: $y = 1$
- 4) vertex: (6,1); axis of symmetry: $x = 1$

245 What is the vertex of the parabola represented by the equation $y = -2x^2 + 24x - 100$?

- 1) $x = -6$
- 2) $x = 6$
- 3) (6, -28)
- 4) (-6, -316)

246 The graph of a parabola is represented by the equation $y = ax^2$ where a is a positive integer. If a is multiplied by 2, the new parabola will become

- 1) narrower and open downward
- 2) narrower and open upward
- 3) wider and open downward
- 4) wider and open upward

247 The expression $\frac{2x + 13}{2x + 6} - \frac{3x - 6}{2x + 6}$ is equivalent to

- 1) $\frac{-x + 19}{2(x + 3)}$
- 2) $\frac{-x + 7}{2(x + 3)}$
- 3) $\frac{5x + 19}{2(x + 3)}$
- 4) $\frac{5x + 7}{4x + 12}$

248 Which set of data can be classified as quantitative?

- 1) first names of students in a chess club
- 2) ages of students in a government class
- 3) hair colors of students in a debate club
- 4) favorite sports of students in a gym class

249 In a given linear equation, the value of the independent variable decreases at a constant rate while the value of the dependent variable increases at a constant rate. The slope of this line is

- 1) positive
- 2) negative
- 3) zero
- 4) undefined

Integrated Algebra Multiple Choice Regents Exam Questions

www.jmap.org

250 What is $2\sqrt{45}$ expressed in simplest radical form?

- 1) $3\sqrt{5}$
- 2) $5\sqrt{5}$
- 3) $6\sqrt{5}$
- 4) $18\sqrt{5}$

251 Which set builder notation describes $\{-2, -1, 0, 1, 2, 3\}$?

- 1) $\{x \mid -3 \leq x \leq 3, \text{ where } x \text{ is an integer}\}$
- 2) $\{x \mid -3 < x \leq 4, \text{ where } x \text{ is an integer}\}$
- 3) $\{x \mid -2 < x < 3, \text{ where } x \text{ is an integer}\}$
- 4) $\{x \mid -2 \leq x < 4, \text{ where } x \text{ is an integer}\}$

252 Mr. Smith invested \$2,500 in a savings account that earns 3% interest compounded annually. He made no additional deposits or withdrawals. Which expression can be used to determine the number of dollars in this account at the end of 4 years?

- 1) $2500(1 + 0.03)^4$
- 2) $2500(1 + 0.3)^4$
- 3) $2500(1 + 0.04)^3$
- 4) $2500(1 + 0.4)^3$

253 Byron is 3 years older than Doug. The product of their ages is 40. How old is Doug?

- 1) 10
- 2) 8
- 3) 5
- 4) 4

254 Which set of coordinates is a solution of the equation $2x - y = 11$?

- 1) $(-6, 1)$
- 2) $(-1, 9)$
- 3) $(0, 11)$
- 4) $(2, -7)$

255 The box-and-whisker plot below represents the ages of 12 people.

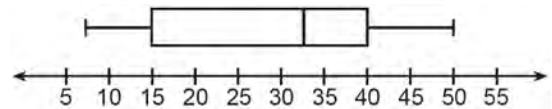

What percentage of these people are age 15 or older?

- 1) 25
- 2) 35
- 3) 75
- 4) 85

256 Given: $A = \{1, 3, 5, 7, 9\}$

$$B = \{2, 4, 6, 8, 10\}$$

$$C = \{2, 3, 5, 7\}$$

$$D = \{1, 2, 3, 4, 5, 6, 7, 8, 9, 10\}$$

What statement is *false*?

- 1) $A \cup B \cup C = D$
- 2) $A \cap B \cap C = \{ \}$
- 3) $A \cup C = \{1, 2, 3, 5, 7\}$
- 4) $A \cap C = \{3, 5, 7\}$

Integrated Algebra Multiple Choice Regents Exam Questions

www.jmap.org

257 Which graph represents the inequality $y > 3$?

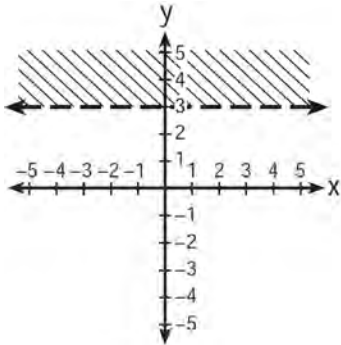

1)

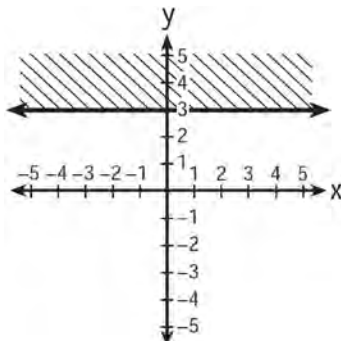

2)

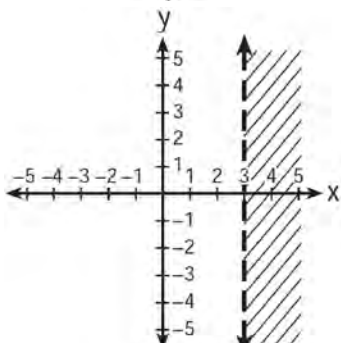

3)

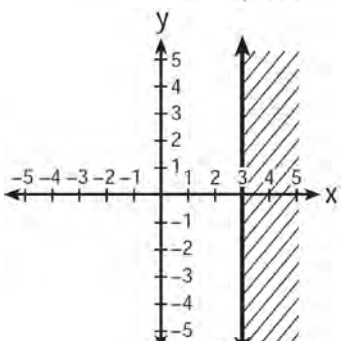

4)

258 The volume of a cylindrical can is 32π cubic inches. If the height of the can is 2 inches, what is its radius, in inches?

- 1) 8
- 2) 2
- 3) 16
- 4) 4

259 Which point lies on the graph represented by the equation $3y + 2x = 8$?

- 1) $(-2, 7)$
- 2) $(0, 4)$
- 3) $(2, 4)$
- 4) $(7, -2)$

260 Campsite A and campsite B are located directly opposite each other on the shores of Lake Omega, as shown in the diagram below. The two campsites form a right triangle with Sam's position, S . The distance from campsite B to Sam's position is 1,300 yards, and campsite A is 1,700 yards from his position.

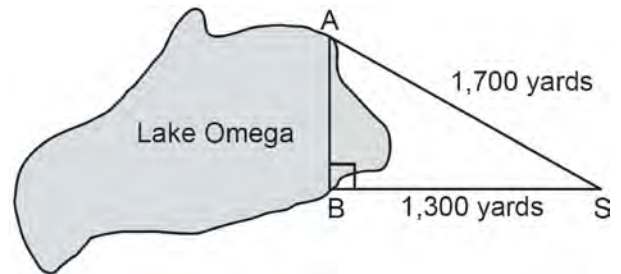

What is the distance from campsite A to campsite B , to the nearest yard?

- 1) 1,095
- 2) 1,096
- 3) 2,140
- 4) 2,141

Integrated Algebra Multiple Choice Regents Exam Questions

www.jmap.org

- 261 The bull's-eye of a dartboard has a radius of 2 inches and the entire board has a radius of 9 inches, as shown in the diagram below.

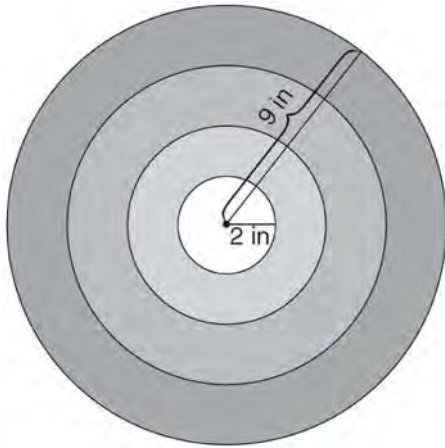

If a dart is thrown and hits the board, what is the probability that the dart will land in the bull's-eye?

- 1) $\frac{2}{9}$
 - 2) $\frac{7}{9}$
 - 3) $\frac{4}{81}$
 - 4) $\frac{49}{81}$
- 262 The total score in a football game was 72 points. The winning team scored 12 points more than the losing team. How many points did the winning team score?
- 1) 30
 - 2) 42
 - 3) 54
 - 4) 60

- 263 Timmy bought a skateboard and two helmets for a total of d dollars. If each helmet cost h dollars, the cost of the skateboard could be represented by

- 1) $2dh$
- 2) $\frac{dh}{2}$
- 3) $d - 2h$
- 4) $d - \frac{h}{2}$

- 264 A system of equations is graphed on the set of axes below.

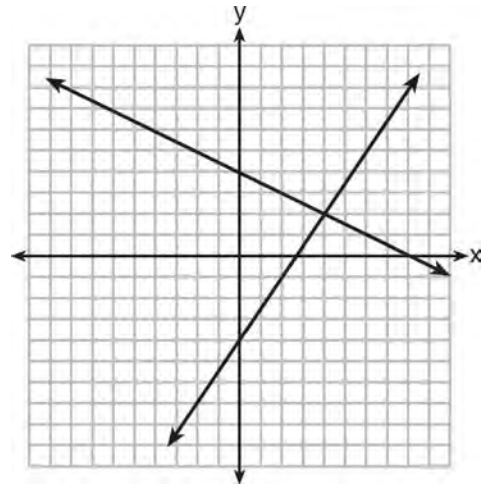

The solution of this system is

- 1) (0,4)
 - 2) (2,4)
 - 3) (4,2)
 - 4) (8,0)
- 265 When $8x^2 + 3x + 2$ is subtracted from $9x^2 - 3x - 4$, the result is
- 1) $x^2 - 2$
 - 2) $17x^2 - 2$
 - 3) $-x^2 + 6x + 6$
 - 4) $x^2 - 6x - 6$

Integrated Algebra Multiple Choice Regents Exam Questions

www.jmap.org

266 Which expression is equivalent to

$$\frac{2x^6 - 18x^4 + 2x^2}{2x^2}?$$

- 1) $x^3 - 9x^2$
- 2) $x^4 - 9x^2$
- 3) $x^3 - 9x^2 + 1$
- 4) $x^4 - 9x^2 + 1$

267 What is the perimeter of the figure shown below, which consists of an isosceles trapezoid and a semicircle?

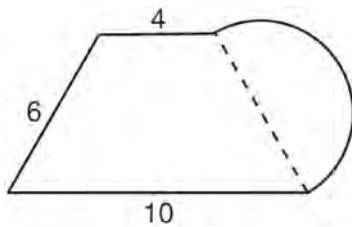

- 1) $20 + 3\pi$
- 2) $20 + 6\pi$
- 3) $26 + 3\pi$
- 4) $26 + 6\pi$

268 The formula for the volume of a pyramid is

$$V = \frac{1}{3}Bh. \text{ What is } h \text{ expressed in terms of } B \text{ and } V?$$

- 1) $h = \frac{1}{3}VB$
- 2) $h = \frac{V}{3B}$
- 3) $h = \frac{3V}{B}$
- 4) $h = 3VB$

269 Jason's part-time job pays him \$155 a week. If he has already saved \$375, what is the minimum number of weeks he needs to work in order to have enough money to buy a dirt bike for \$900?

- 1) 8
- 2) 9
- 3) 3
- 4) 4

270 A scatter plot was constructed on the graph below and a line of best fit was drawn.

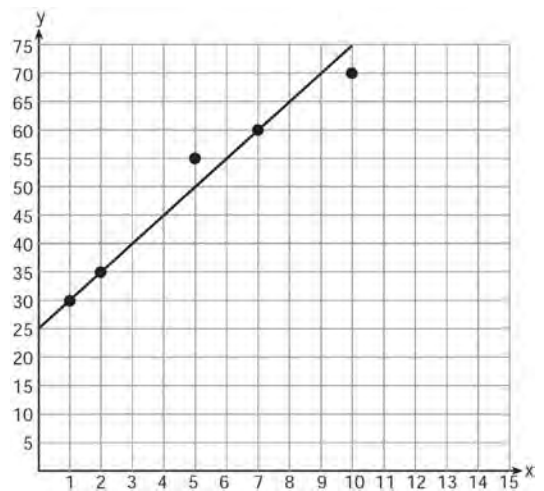

What is the equation of this line of best fit?

- 1) $y = x + 5$
- 2) $y = x + 25$
- 3) $y = 5x + 5$
- 4) $y = 5x + 25$

Integrated Algebra Multiple Choice Regents Exam Questions

- 271 Cassandra bought an antique dresser for \$500. If the value of her dresser increases 6% annually, what will be the value of Cassandra's dresser at the end of 3 years to the *nearest dollar*?
- 1) \$415
 - 2) \$590
 - 3) \$596
 - 4) \$770

- 272 A spinner is divided into eight equal regions as shown in the diagram below.

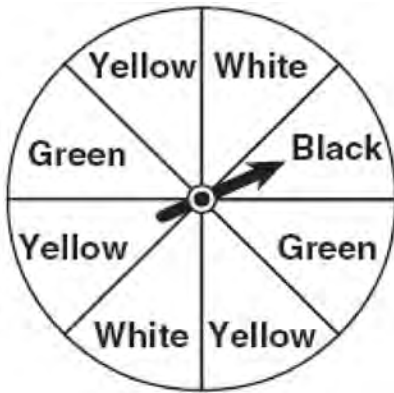

- Which event is most likely to occur in one spin?
- 1) The arrow will land in a green or white area.
 - 2) The arrow will land in a green or black area.
 - 3) The arrow will land in a yellow or black area.
 - 4) The arrow will land in a yellow or green area.

- 273 The expression $x^2 - 16$ is equivalent to
- 1) $(x + 2)(x - 8)$
 - 2) $(x - 2)(x + 8)$
 - 3) $(x + 4)(x - 4)$
 - 4) $(x + 8)(x - 8)$

- 274 The local ice cream stand offers three flavors of soft-serve ice cream: vanilla, chocolate, and strawberry; two types of cone: sugar and wafer; and three toppings: sprinkles, nuts, and cookie crumbs. If Dawn does not order vanilla ice cream, how many different choices can she make that have one flavor of ice cream, one type of cone, and one topping?
- 1) 7
 - 2) 8
 - 3) 12
 - 4) 18

- 275 The faces of a cube are numbered from 1 to 6. If the cube is tossed once, what is the probability that a prime number or a number divisible by 2 is obtained?
- 1) $\frac{6}{6}$
 - 2) $\frac{5}{6}$
 - 3) $\frac{4}{6}$
 - 4) $\frac{1}{6}$

- 276 Daniel's Print Shop purchased a new printer for \$35,000. Each year it depreciates (loses value) at a rate of 5%. What will its approximate value be at the end of the fourth year?
- 1) \$33,250.00
 - 2) \$30,008.13
 - 3) \$28,507.72
 - 4) \$27,082.33

Integrated Algebra Multiple Choice Regents Exam Questions

www.jmap.org

277 What is the value of the y-coordinate of the solution to the system of equations $x - 2y = 1$ and $x + 4y = 7$?

- 1) 1
- 2) -1
- 3) 3
- 4) 4

278 Which graph represents a function?

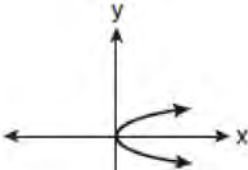

1)

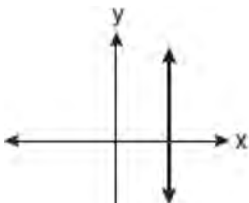

2)

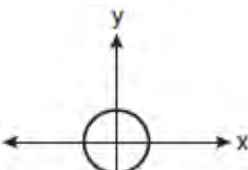

3)

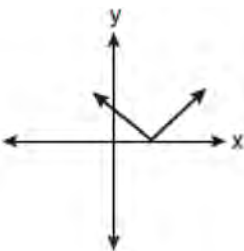

4)

279 The sum of two numbers is 47, and their difference is 15. What is the larger number?

- 1) 16
- 2) 31
- 3) 32
- 4) 36

280 Lenny made a cube in technology class. Each edge measured 1.5 cm. What is the volume of the cube in cubic centimeters?

- 1) 2.25
- 2) 3.375
- 3) 9.0
- 4) 13.5

281 What is the product of 8.4×10^8 and 4.2×10^3 written in scientific notation?

- 1) 2.0×10^5
- 2) 12.6×10^{11}
- 3) 35.28×10^{11}
- 4) 3.528×10^{12}

282 A rectangle has an area of 24 square units. The width is 5 units less than the length. What is the length, in units, of the rectangle?

- 1) 6
- 2) 8
- 3) 3
- 4) 19

Integrated Algebra Multiple Choice Regents Exam Questions

www.jmap.org

283 Which value of x is in the solution set of the inequality $-2x + 5 > 17$?

- 1) -8
- 2) -6
- 3) -4
- 4) 12

284 John is going to line up his four golf trophies on a shelf in his bedroom. How many different possible arrangements can he make?

- 1) 24
- 2) 16
- 3) 10
- 4) 4

285 The groundskeeper is replacing the turf on a football field. His measurements of the field are 130 yards by 60 yards. The actual measurements are 120 yards by 54 yards. Which expression represents the relative error in the measurement?

- 1) $\frac{(130)(60) - (120)(54)}{(120)(54)}$
- 2) $\frac{(120)(54)}{(130)(60) - (120)(54)}$
- 3) $\frac{(130)(60) - (120)(54)}{(130)(60)}$
- 4) $\frac{(130)(60)}{(130)(60) - (120)(54)}$

286 Which property is illustrated by the equation $ax + ay = a(x + y)$?

- 1) associative
- 2) commutative
- 3) distributive
- 4) identity

287 The equations $5x + 2y = 48$ and $3x + 2y = 32$ represent the money collected from school concert ticket sales during two class periods. If x represents the cost for each adult ticket and y represents the cost for each student ticket, what is the cost for each adult ticket?

- 1) \$20
- 2) \$10
- 3) \$8
- 4) \$4

288 What is the product of $-3x^2y$ and $(5xy^2 + xy)$?

- 1) $-15x^3y^3 - 3x^3y^2$
- 2) $-15x^3y^3 - 3x^3y$
- 3) $-15x^2y^2 - 3x^2y$
- 4) $-15x^3y^3 + xy$

289 In the diagram of $\triangle ABC$ shown below, $BC = 10$ and $AB = 16$.

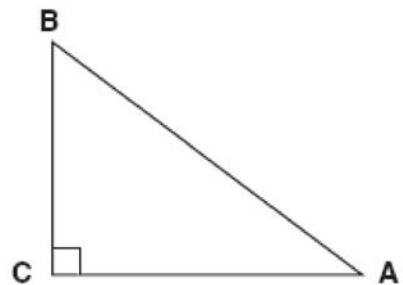

To the nearest tenth of a degree, what is the measure of the largest acute angle in the triangle?

- 1) 32.0
- 2) 38.7
- 3) 51.3
- 4) 90.0

Integrated Algebra Multiple Choice Regents Exam Questions

www.jmap.org

- 290 The set $\{11, 12\}$ is equivalent to
- 1) $\{x \mid 11 < x < 12, \text{ where } x \text{ is an integer}\}$
 - 2) $\{x \mid 11 < x \leq 12, \text{ where } x \text{ is an integer}\}$
 - 3) $\{x \mid 10 \leq x < 12, \text{ where } x \text{ is an integer}\}$
 - 4) $\{x \mid 10 < x \leq 12, \text{ where } x \text{ is an integer}\}$

- 291 Nancy's rectangular garden is represented in the diagram below.

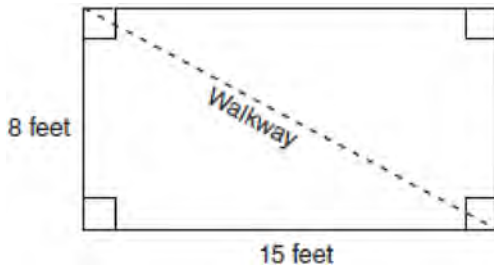

If a diagonal walkway crosses her garden, what is its length, in feet?

- 1) 17
 - 2) 22
 - 3) $\sqrt{161}$
 - 4) $\sqrt{529}$
- 292 Which value of x is in the solution set of $\frac{4}{3}x + 5 < 17$?
- 1) 8
 - 2) 9
 - 3) 12
 - 4) 16

- 293 The spinner below is divided into eight equal regions and is spun once. What is the probability of *not* getting red?

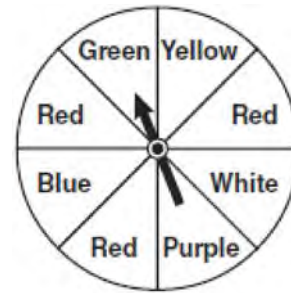

- 1) $\frac{3}{5}$
 - 2) $\frac{3}{8}$
 - 3) $\frac{5}{8}$
 - 4) $\frac{7}{8}$
- 294 Which data set describes a situation that could be classified as qualitative?
- 1) the ages of the students in Ms. Marshall's Spanish class
 - 2) the test scores of the students in Ms. Fitzgerald's class
 - 3) the favorite ice cream flavor of each of Mr. Hayden's students
 - 4) the heights of the players on the East High School basketball team

- 295 Which equation represents a line parallel to the x -axis?
- 1) $y = -5$
 - 2) $y = -5x$
 - 3) $x = 3$
 - 4) $x = 3y$

Integrated Algebra Multiple Choice Regents Exam Questions

www.jmap.org

- 296 What are the vertex and the axis of symmetry of the parabola shown in the diagram below?

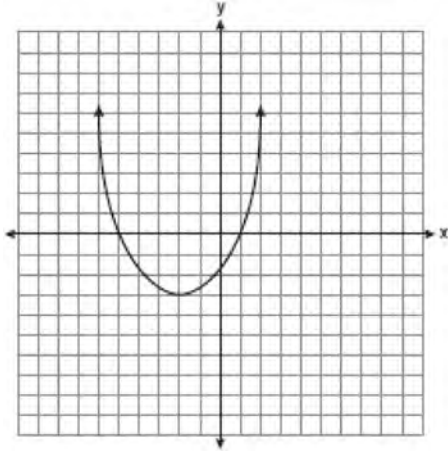

- 1) The vertex is $(-2, -3)$, and the axis of symmetry is $x = -2$.
- 2) The vertex is $(-2, -3)$, and the axis of symmetry is $y = -2$.
- 3) The vertex is $(-3, -2)$, and the axis of symmetry is $y = -2$.
- 4) The vertex is $(-3, -2)$, and the axis of symmetry is $x = -2$.

- 297 What is the value of x , in inches, in the right triangle below?

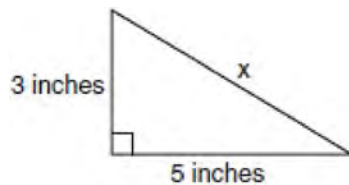

- 1) $\sqrt{15}$
- 2) 8
- 3) $\sqrt{34}$
- 4) 4

- 298 A playground in a local community consists of a rectangle and two semicircles, as shown in the diagram below.

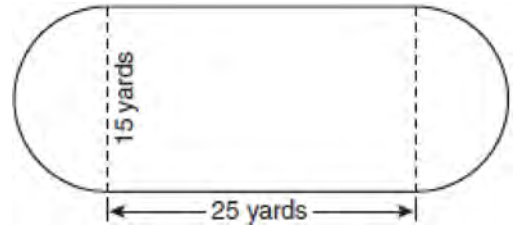

Which expression represents the amount of fencing, in yards, that would be needed to completely enclose the playground?

- 1) $15\pi + 50$
 - 2) $15\pi + 80$
 - 3) $30\pi + 50$
 - 4) $30\pi + 80$
- 299 Which interval notation represents the set of all numbers from 2 through 7, inclusive?
- 1) $(2, 7]$
 - 2) $(2, 7)$
 - 3) $[2, 7)$
 - 4) $[2, 7]$

- 300 What is the sum of $\frac{d}{2}$ and $\frac{2d}{3}$ expressed in simplest form?

- 1) $\frac{3d}{5}$
- 2) $\frac{3d}{6}$
- 3) $\frac{7d}{5}$
- 4) $\frac{7d}{6}$

Integrated Algebra Multiple Choice Regents Exam Questions

www.jmap.org

301 Which expression represents $\frac{27x^{18}y^5}{9x^6y}$ in simplest form?

- 1) $3x^{12}y^4$
- 2) $3x^3y^5$
- 3) $18x^{12}y^4$
- 4) $18x^3y^5$

302 Consider the set of integers greater than -2 and less than 6 . A subset of this set is the positive factors of 5 . What is the complement of this subset?

- 1) $\{0, 2, 3, 4\}$
- 2) $\{-1, 0, 2, 3, 4\}$
- 3) $\{-2, -1, 0, 2, 3, 4, 6\}$
- 4) $\{-2, -1, 0, 1, 2, 3, 4, 5, 6\}$

303 Which value of x is in the solution set of the inequality $-2(x - 5) < 4$?

- 1) 0
- 2) 2
- 3) 3
- 4) 5

304 Which expression is equivalent to $9x^2 - 16$?

- 1) $(3x + 4)(3x - 4)$
- 2) $(3x - 4)(3x - 4)$
- 3) $(3x + 8)(3x - 8)$
- 4) $(3x - 8)(3x - 8)$

305 Antwaan leaves a cup of hot chocolate on the counter in his kitchen. Which graph is the best representation of the change in temperature of his hot chocolate over time?

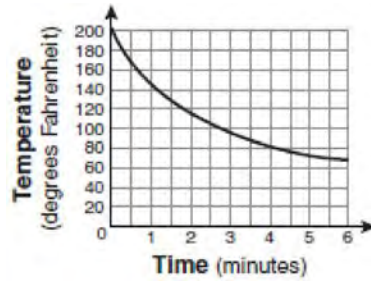

1)

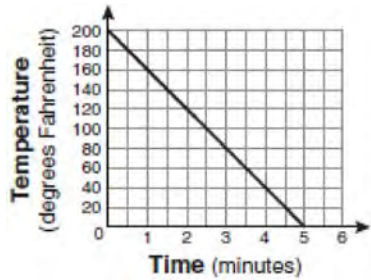

2)

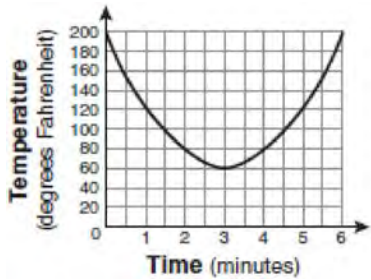

3)

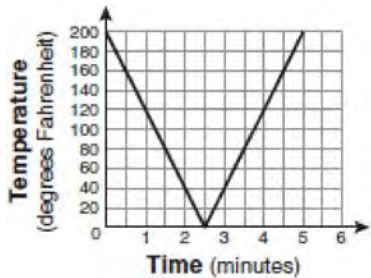

4)

Integrated Algebra Multiple Choice Regents Exam Questions

www.jmap.org

- 306 Tanya runs diagonally across a rectangular field that has a length of 40 yards and a width of 30 yards, as shown in the diagram below.

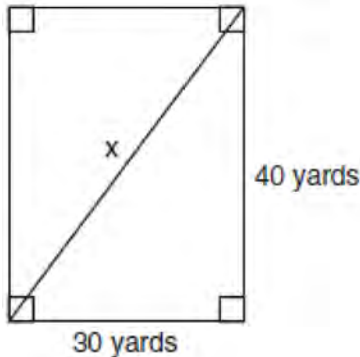

What is the length of the diagonal, in yards, that Tanya runs?

- 1) 50
2) 60
3) 70
4) 80
- 307 What is the value of the third quartile shown on the box-and-whisker plot below?

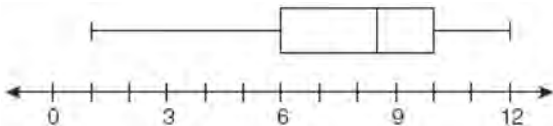

- 1) 6
2) 8.5
3) 10
4) 12
- 308 For which value of x is $\frac{x-3}{x^2-4}$ undefined?

- 1) -2
2) 0
3) 3
4) 4

- 309 The length of the hypotenuse of a right triangle is 34 inches and the length of one of its legs is 16 inches. What is the length, in inches, of the other leg of this right triangle?

- 1) 16
2) 18
3) 25
4) 30

- 310 Which ordered pair is in the solution set of the following system of inequalities?

$$y < \frac{1}{2}x + 4$$

$$y \geq -x + 1$$

- 1) (-5,3)
2) (0,4)
3) (3,-5)
4) (4,0)

- 311 The expression $9x^2 - 100$ is equivalent to

- 1) $(9x - 10)(x + 10)$
2) $(3x - 10)(3x + 10)$
3) $(3x - 100)(3x - 1)$
4) $(9x - 100)(x + 1)$

- 312 If the speed of sound is 344 meters per second, what is the approximate speed of sound, in meters per hour?

60 seconds = 1 minute
60 minutes = 1 hour

- 1) 20,640
2) 41,280
3) 123,840
4) 1,238,400

Integrated Algebra Multiple Choice Regents Exam Questions

www.jmap.org

313 The diagram below shows right triangle UPC .

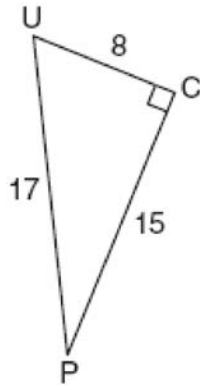

Which ratio represents the sine of $\angle U$?

- 1) $\frac{15}{8}$
- 2) $\frac{15}{17}$
- 3) $\frac{8}{15}$
- 4) $\frac{8}{17}$

314 What is the quotient of 8.05×10^6 and 3.5×10^2 ?

- 1) 2.3×10^3
- 2) 2.3×10^4
- 3) 2.3×10^8
- 4) 2.3×10^{12}

315 What is $\frac{\sqrt{32}}{4}$ expressed in simplest radical form?

- 1) $\sqrt{2}$
- 2) $4\sqrt{2}$
- 3) $\sqrt{8}$
- 4) $\frac{\sqrt{8}}{2}$

316 The ages of three brothers are consecutive even integers. Three times the age of the youngest brother exceeds the oldest brother's age by 48 years. What is the age of the youngest brother?

- 1) 14
- 2) 18
- 3) 22
- 4) 26

317 What is the value of the expression $|-5x + 12|$ when $x = 5$?

- 1) -37
- 2) -13
- 3) 13
- 4) 37

318 Which ordered pair is a solution to the system of equations $y = x$ and $y = x^2 - 2$?

- 1) $(-2, -2)$
- 2) $(-1, 1)$
- 3) $(0, 0)$
- 4) $(2, 2)$

319 Factored completely, the expression $2x^2 + 10x - 12$ is equivalent to

- 1) $2(x - 6)(x + 1)$
- 2) $2(x + 6)(x - 1)$
- 3) $2(x + 2)(x + 3)$
- 4) $2(x - 2)(x - 3)$

320 The diagram below shows the graph of $y = |x - 3|$.

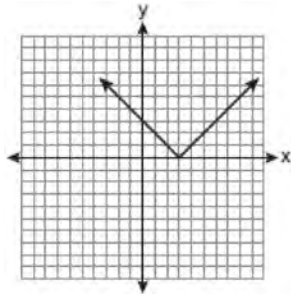

Which diagram shows the graph of $y = -|x - 3|$?

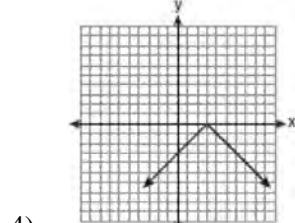
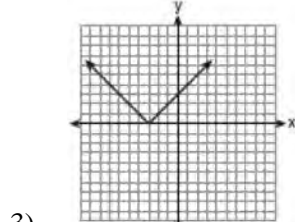
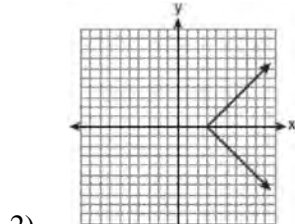
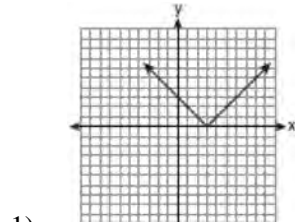

321 The gas tank in a car holds a total of 16 gallons of gas. The car travels 75 miles on 4 gallons of gas. If the gas tank is full at the beginning of a trip, which graph represents the rate of change in the amount of gas in the tank?

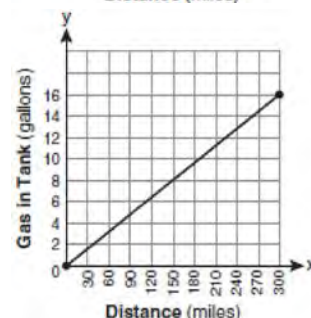
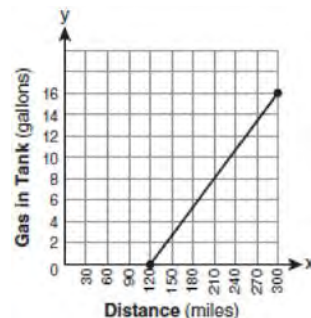
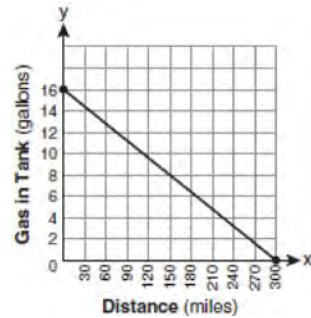
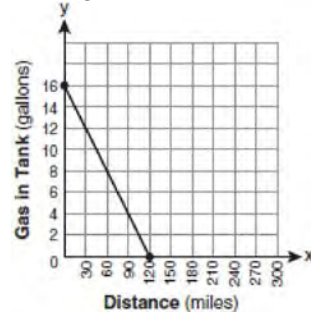

Integrated Algebra Multiple Choice Regents Exam Questions

www.jmap.org

322 The statement $2 + 0 = 2$ is an example of the use of which property of real numbers?

- 1) associative
- 2) additive identity
- 3) additive inverse
- 4) distributive

323 If $a + ar = b + r$, the value of a in terms of b and r can be expressed as

- 1) $\frac{b}{r} + 1$
- 2) $\frac{1+b}{r}$
- 3) $\frac{b+r}{1+r}$
- 4) $\frac{1+b}{r+b}$

324 Which value of x is a solution of $\frac{5}{x} = \frac{x+13}{6}$?

- 1) -2
- 2) -3
- 3) -10
- 4) -15

325 What is an equation of the line that passes through the point $(4, -6)$ and has a slope of -3 ?

- 1) $y = -3x + 6$
- 2) $y = -3x - 6$
- 3) $y = -3x + 10$
- 4) $y = -3x + 14$

326 If $3ax + b = c$, then x equals

- 1) $c - b + 3a$
- 2) $c + b - 3a$
- 3) $\frac{c - b}{3a}$
- 4) $\frac{b - c}{3a}$

327 Which graph represents a linear function?

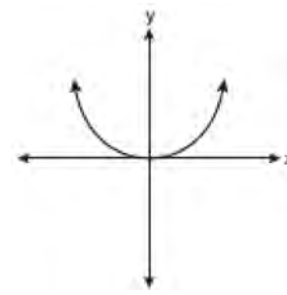
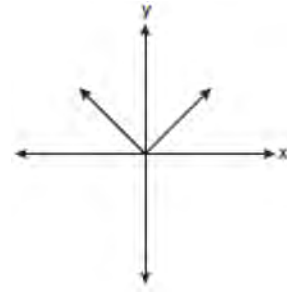
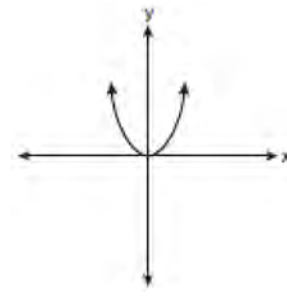
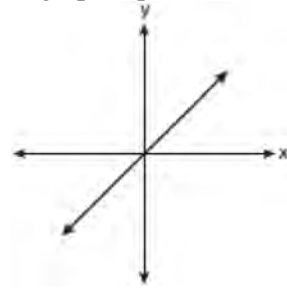

Integrated Algebra Multiple Choice Regents Exam Questions

www.jmap.org

328 Nicole's aerobics class exercises to fast-paced music. If the rate of the music is 120 beats per minute, how many beats would there be in a class that is 0.75 hour long?

- 1) 90
- 2) 160
- 3) 5,400
- 4) 7,200

329 Given:

$$\text{Set } A = \{(-2, -1), (-1, 0), (1, 8)\}$$

$$\text{Set } B = \{(-3, -4), (-2, -1), (-1, 2), (1, 8)\}$$

What is the intersection of sets A and B ?

- 1) $\{(1, 8)\}$
- 2) $\{(-2, -1)\}$
- 3) $\{(-2, -1), (1, 8)\}$
- 4) $\{(-3, -4), (-2, -1), (-1, 2), (-1, 0), (1, 8)\}$

330 In the right triangle shown in the diagram below, what is the value of x to the *nearest whole number*?

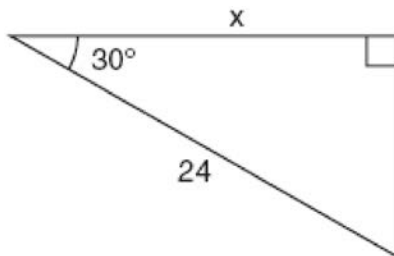

- 1) 12
- 2) 14
- 3) 21
- 4) 28

331 A swim team member performs a dive from a 14-foot-high springboard. The parabola below shows the path of her dive.

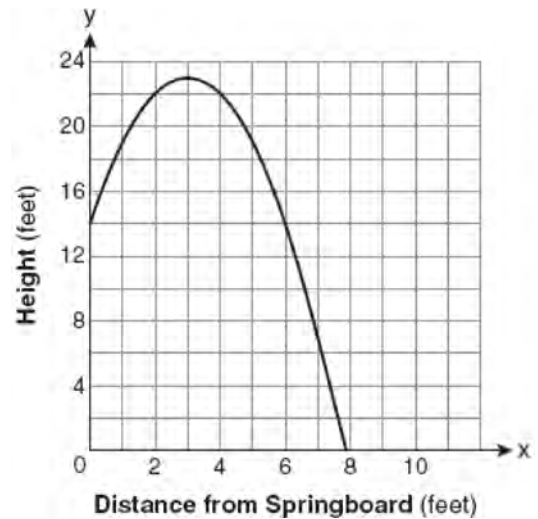

Which equation represents the axis of symmetry?

- 1) $x = 3$
- 2) $y = 3$
- 3) $x = 23$
- 4) $y = 23$

332 Ryan estimates the measurement of the volume of a popcorn container to be 282 cubic inches. The actual volume of the popcorn container is 289 cubic inches. What is the relative error of Ryan's measurement to the *nearest thousandth*?

- 1) 0.024
- 2) 0.025
- 3) 0.096
- 4) 1.025

Integrated Algebra Multiple Choice Regents Exam Questions

www.jmap.org

- 333 For 10 days, Romero kept a record of the number of hours he spent listening to music. The information is shown in the table below.

Day	1	2	3	4	5	6	7	8	9	10
Hours	9	3	2	6	8	6	10	4	5	2

Which scatter plot shows Romero's data graphically?

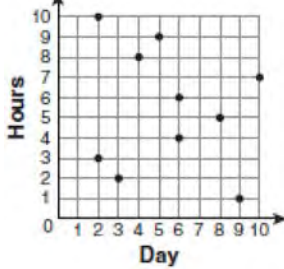

1)

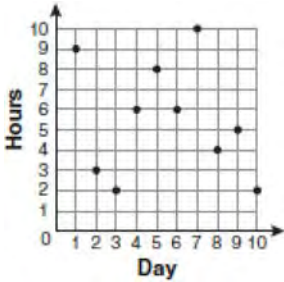

2)

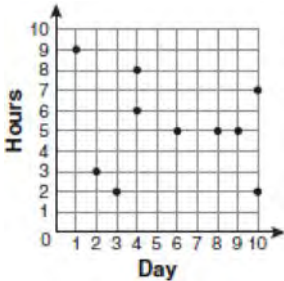

3)

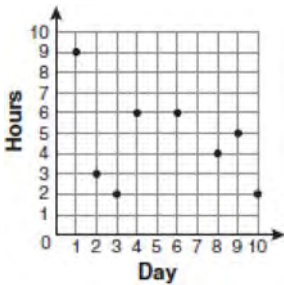

4)

- 334 When $4x^2 + 7x - 5$ is subtracted from $9x^2 - 2x + 3$, the result is

- 1) $5x^2 + 5x - 2$
- 2) $5x^2 - 9x + 8$
- 3) $-5x^2 + 5x - 2$
- 4) $-5x^2 + 9x - 8$

- 335 Which expression represents $\frac{2x^2 - 12x}{x - 6}$ in simplest form?

- 1) 0
- 2) $2x$
- 3) $4x$
- 4) $2x + 2$

- 336 The faces of a cube are numbered from 1 to 6. If the cube is rolled once, which outcome is *least* likely to occur?

- 1) rolling an odd number
- 2) rolling an even number
- 3) rolling a number less than 6
- 4) rolling a number greater than 4

- 337 Mrs. Ayer is painting the outside of her son's toy box, including the top and bottom. The toy box measures 3 feet long, 1.5 feet wide, and 2 feet high. What is the total surface area she will paint?

- 1) 9.0 ft^2
- 2) 13.5 ft^2
- 3) 22.5 ft^2
- 4) 27.0 ft^2

Integrated Algebra Multiple Choice Regents Exam Questions

www.jmap.org

338 The solution to the equation $x^2 - 6x = 0$ is

- 1) 0, only
- 2) 6, only
- 3) 0 and 6
- 4) $\pm\sqrt{6}$

339 What is the speed, in meters per second, of a paper airplane that flies 24 meters in 6 seconds?

- 1) 144
- 2) 30
- 3) 18
- 4) 4

340 The New York Volleyball Association invited 64 teams to compete in a tournament. After each round, half of the teams were eliminated. Which equation represents the number of teams, t , that remained in the tournament after r rounds?

- 1) $t = 64(r)^{0.5}$
- 2) $t = 64(-0.5)^r$
- 3) $t = 64(1.5)^r$
- 4) $t = 64(0.5)^r$

341 Given:

$A = \{\text{All even integers from 2 to 20, inclusive}\}$

$B = \{10, 12, 14, 16, 18\}$

What is the complement of set B within the universe of set A ?

- 1) $\{4, 6, 8\}$
- 2) $\{2, 4, 6, 8\}$
- 3) $\{4, 6, 8, 20\}$
- 4) $\{2, 4, 6, 8, 20\}$

342 Mrs. Smith wrote "Eight less than three times a number is greater than fifteen" on the board. If x represents the number, which inequality is a correct translation of this statement?

- 1) $3x - 8 > 15$
- 2) $3x - 8 < 15$
- 3) $8 - 3x > 15$
- 4) $8 - 3x < 15$

343 Which expression represents $(3x^2y^4)(4xy^2)$ in simplest form?

- 1) $12x^2y^8$
- 2) $12x^2y^6$
- 3) $12x^3y^8$
- 4) $12x^3y^6$

344 A tree casts a 25-foot shadow on a sunny day, as shown in the diagram below.

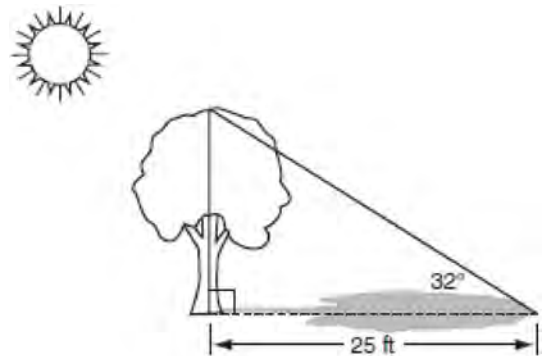

If the angle of elevation from the tip of the shadow to the top of the tree is 32° , what is the height of the tree to the nearest tenth of a foot?

- 1) 13.2
- 2) 15.6
- 3) 21.2
- 4) 40.0

Integrated Algebra Multiple Choice Regents Exam Questions

www.jmap.org

- 345 Which equation could be used to find the measure of one acute angle in the right triangle shown below?

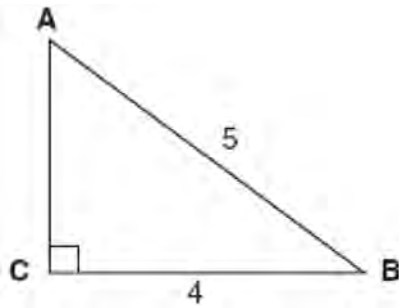

- 1) $\sin A = \frac{4}{5}$
 - 2) $\tan A = \frac{5}{4}$
 - 3) $\cos B = \frac{5}{4}$
 - 4) $\tan B = \frac{4}{5}$
- 346 The box-and-whisker plot below represents students' scores on a recent English test.

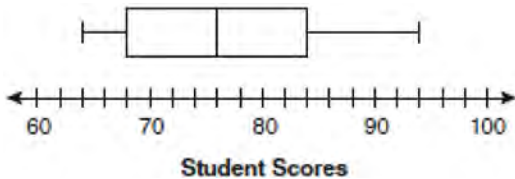

What is the value of the upper quartile?

- 1) 68
- 2) 76
- 3) 84
- 4) 94

- 347 What is the sum of $\frac{3}{2x}$ and $\frac{4}{3x}$ expressed in simplest form?

- 1) $\frac{12}{6x^2}$
- 2) $\frac{17}{6x}$
- 3) $\frac{7}{5x}$
- 4) $\frac{17}{12x}$

- 348 What is the product of $\frac{4x}{x-1}$ and $\frac{x^2-1}{3x+3}$ expressed in simplest form?

- 1) $\frac{4x}{3}$
- 2) $\frac{4x^2}{3}$
- 3) $\frac{4x^2}{3(x+1)}$
- 4) $\frac{4(x+1)}{3}$

- 349 What is the product of 12 and 4.2×10^6 expressed in scientific notation?

- 1) 50.4×10^6
- 2) 50.4×10^7
- 3) 5.04×10^6
- 4) 5.04×10^7

Integrated Algebra Multiple Choice Regents Exam Questions

www.jmap.org

350 Which expression is equivalent to $(3x^2)^3$?

- 1) $9x^5$
- 2) $9x^6$
- 3) $27x^5$
- 4) $27x^6$

351 What is an equation of the line that passes through the point $(3, -1)$ and has a slope of 2?

- 1) $y = 2x + 5$
- 2) $y = 2x - 1$
- 3) $y = 2x - 4$
- 4) $y = 2x - 7$

352 The table below shows a cumulative frequency distribution of runners' ages.

Cumulative Frequency Distribution of Runners' Ages

Age Group	Total
20-29	8
20-39	18
20-49	25
20-59	31
20-69	35

According to the table, how many runners are in their forties?

- 1) 25
- 2) 10
- 3) 7
- 4) 6

353 Which data set describes a situation that could be classified as qualitative?

- 1) the elevations of the five highest mountains in the world
- 2) the ages of presidents at the time of their inauguration
- 3) the opinions of students regarding school lunches
- 4) the shoe sizes of players on the basketball team

354 Don placed a ladder against the side of his house as shown in the diagram below.

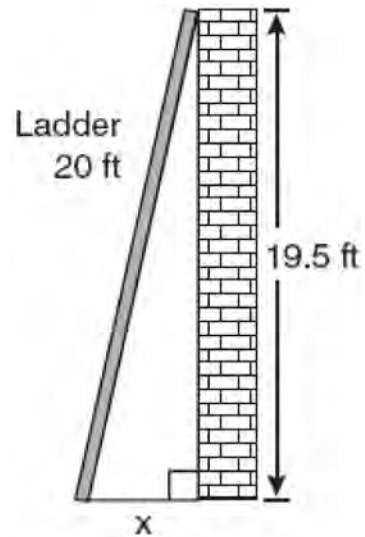

Which equation could be used to find the distance, x , from the foot of the ladder to the base of the house?

- 1) $x = 20 - 19.5$
- 2) $x = 20^2 - 19.5^2$
- 3) $x = \sqrt{20^2 - 19.5^2}$
- 4) $x = \sqrt{20^2 + 19.5^2}$

Integrated Algebra Multiple Choice Regents Exam Questions

www.jmap.org

355 Which graph represents the solution of $3y - 9 \leq 6x$?

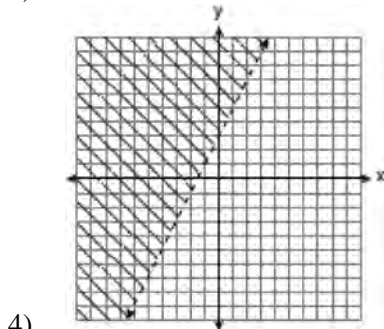
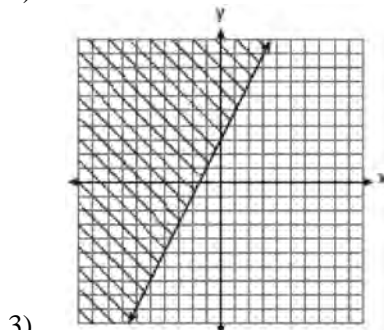
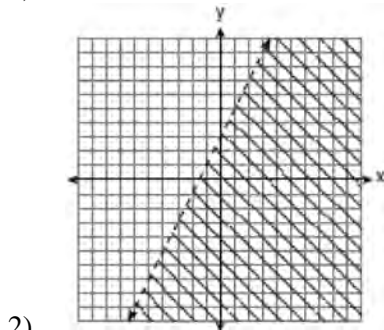
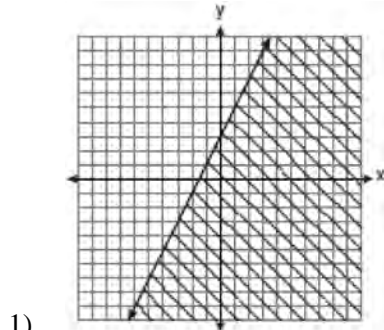

356 A school wants to add a coed soccer program. To determine student interest in the program, a survey will be taken. In order to get an unbiased sample, which group should the school survey?

- 1) every third student entering the building
- 2) every member of the varsity football team
- 3) every member in Ms. Zimmer's drama classes
- 4) every student having a second-period French class

357 Which ordered pair is a solution of the system of equations $y = x^2 - x - 20$ and $y = 3x - 15$?

- 1) $(-5, -30)$
- 2) $(-1, -18)$
- 3) $(0, 5)$
- 4) $(5, -1)$

358 What is the slope of the line that passes through the points $(-6, 1)$ and $(4, -4)$?

- 1) -2
- 2) 2
- 3) $-\frac{1}{2}$
- 4) $\frac{1}{2}$

359 Tamara has a cell phone plan that charges \$0.07 per minute plus a monthly fee of \$19.00. She budgets \$29.50 per month for total cell phone expenses without taxes. What is the maximum number of minutes Tamara could use her phone each month in order to stay within her budget?

- 1) 150
- 2) 271
- 3) 421
- 4) 692

Integrated Algebra Multiple Choice Regents Exam Questions

www.jmap.org

360 What is an equation of the line that passes through the points $(3, -3)$ and $(-3, -3)$?

- 1) $y = 3$
- 2) $x = -3$
- 3) $y = -3$
- 4) $x = y$

361 The equation $y = x^2 + 3x - 18$ is graphed on the set of axes below.

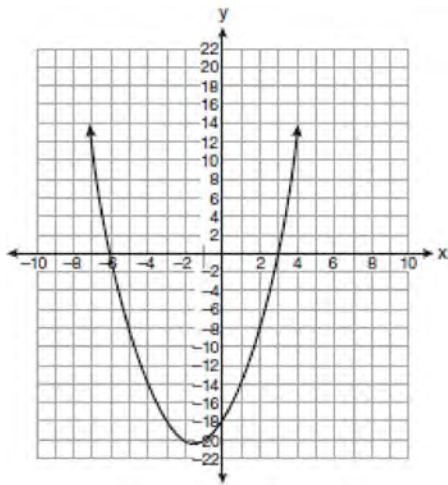

Based on this graph, what are the roots of the equation $x^2 + 3x - 18 = 0$?

- 1) -3 and 6
- 2) 0 and -18
- 3) 3 and -6
- 4) 3 and -18

362 Which equation represents a line that is parallel to the line $y = -4x + 5$?

- 1) $y = -4x + 3$
- 2) $y = -\frac{1}{4}x + 5$
- 3) $y = \frac{1}{4}x + 3$
- 4) $y = 4x + 5$

363 Throughout history, many people have contributed to the development of mathematics. These mathematicians include Pythagoras, Euclid, Hypatia, Euler, Einstein, Agnesi, Fibonacci, and Pascal. What is the probability that a mathematician's name selected at random from those listed will start with either the letter E or the letter A ?

- 1) $\frac{2}{8}$
- 2) $\frac{3}{8}$
- 3) $\frac{4}{8}$
- 4) $\frac{6}{8}$

364 Which verbal expression represents $2(n - 6)$?

- 1) two times n minus six
- 2) two times six minus n
- 3) two times the quantity n less than six
- 4) two times the quantity six less than n

365 Factored, the expression $16x^2 - 25y^2$ is equivalent to

- 1) $(4x - 5y)(4x + 5y)$
- 2) $(4x - 5y)(4x - 5y)$
- 3) $(8x - 5y)(8x + 5y)$
- 4) $(8x - 5y)(8x - 5y)$

366 The expression $\frac{9x^4 - 27x^6}{3x^3}$ is equivalent to

- 1) $3x(1 - 3x)$
- 2) $3x(1 - 3x^2)$
- 3) $3x(1 - 9x^5)$
- 4) $9x^3(1 - x)$

Integrated Algebra Multiple Choice Regents Exam Questions

www.jmap.org

- 367 Which situation should be analyzed using bivariate data?
- 1) Ms. Saleem keeps a list of the amount of time her daughter spends on her social studies homework.
 - 2) Mr. Benjamin tries to see if his students' shoe sizes are directly related to their heights.
 - 3) Mr. DeStefan records his customers' best video game scores during the summer.
 - 4) Mr. Chan keeps track of his daughter's algebra grades for the quarter.

368 In triangle MCT , the measure of $\angle T = 90^\circ$, $MC = 85$ cm, $CT = 84$ cm, and $TM = 13$ cm. Which ratio represents the sine of $\angle C$?

- 1) $\frac{13}{85}$
- 2) $\frac{84}{85}$
- 3) $\frac{13}{84}$
- 4) $\frac{84}{13}$

369 What is the value of x in the equation $\frac{2}{x} - 3 = \frac{26}{x}$?

- 1) -8
- 2) $-\frac{1}{8}$
- 3) $\frac{1}{8}$
- 4) 8

370 What is the value of the y -coordinate of the solution to the system of equations $x + 2y = 9$ and $x - y = 3$?

- 1) 6
- 2) 2
- 3) 3
- 4) 5

371 Which type of graph is shown in the diagram below?

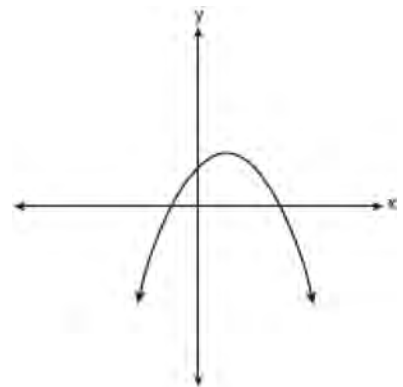

- 1) absolute value
- 2) exponential
- 3) linear
- 4) quadratic

372 What are the vertex and axis of symmetry of the parabola $y = x^2 - 16x + 63$?

- 1) vertex: $(8, -1)$; axis of symmetry: $x = 8$
- 2) vertex: $(8, 1)$; axis of symmetry: $x = 8$
- 3) vertex: $(-8, -1)$; axis of symmetry: $x = -8$
- 4) vertex: $(-8, 1)$; axis of symmetry: $x = -8$

Integrated Algebra Multiple Choice Regents Exam Questions

www.jmap.org

- 373 The center pole of a tent is 8 feet long, and a side of the tent is 12 feet long as shown in the diagram below.

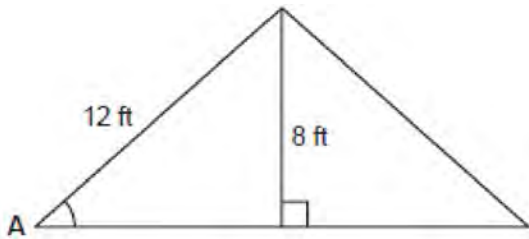

If a right angle is formed where the center pole meets the ground, what is the measure of angle A to the nearest degree?

- 1) 34
 - 2) 42
 - 3) 48
 - 4) 56
- 374 Jack bought 3 slices of cheese pizza and 4 slices of mushroom pizza for a total cost of \$12.50. Grace bought 3 slices of cheese pizza and 2 slices of mushroom pizza for a total cost of \$8.50. What is the cost of one slice of mushroom pizza?
- 1) \$1.50
 - 2) \$2.00
 - 3) \$3.00
 - 4) \$3.50

- 375 What is $\sqrt{32}$ expressed in simplest radical form?
- 1) $16\sqrt{2}$
 - 2) $4\sqrt{2}$
 - 3) $4\sqrt{8}$
 - 4) $2\sqrt{8}$

376 Solve for x: $\frac{3}{5}(x+2) = x-4$

- 1) 8
- 2) 13
- 3) 15
- 4) 23

- 377 The equation $y = -x^2 - 2x + 8$ is graphed on the set of axes below.

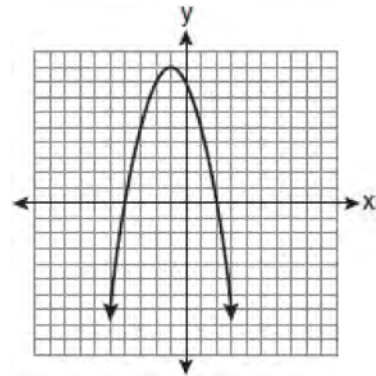

Based on this graph, what are the roots of the equation $-x^2 - 2x + 8 = 0$?

- 1) 8 and 0
- 2) 2 and -4
- 3) 9 and -1
- 4) 4 and -2

- 378 What is the slope of the line that passes through the points $(-5, 4)$ and $(15, -4)$?

- 1) $-\frac{2}{5}$
- 2) 0
- 3) $-\frac{5}{2}$
- 4) undefined

Integrated Algebra Multiple Choice Regents Exam Questions

www.jmap.org

379 What is $\frac{6}{5x} - \frac{2}{3x}$ in simplest form?

- 1) $\frac{8}{15x^2}$
- 2) $\frac{8}{15x}$
- 3) $\frac{4}{15x}$
- 4) $\frac{4}{2x}$

380 What is an equation for the line that passes through the coordinates (2,0) and (0,3)?

- 1) $y = -\frac{3}{2}x + 3$
- 2) $y = -\frac{3}{2}x - 3$
- 3) $y = -\frac{2}{3}x + 2$
- 4) $y = -\frac{2}{3}x - 2$

381 What are the roots of the equation

$$x^2 - 10x + 21 = 0?$$

- 1) 1 and 21
- 2) -5 and -5
- 3) 3 and 7
- 4) -3 and -7

382 Which value of x is in the solution set of the inequality $-4x + 2 > 10$?

- 1) -2
- 2) 2
- 3) 3
- 4) -4

383 The number of hours spent on math homework each week and the final exam grades for twelve students in Mr. Dylan's algebra class are plotted below.

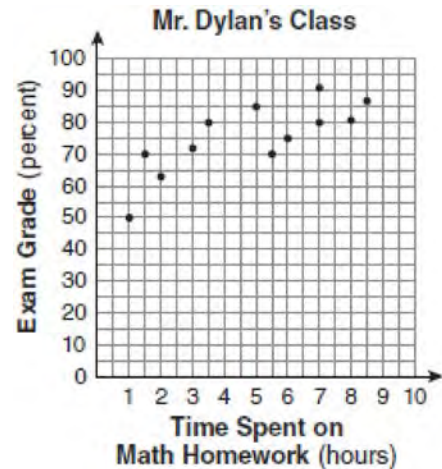

Based on a line of best fit, which exam grade is the best prediction for a student who spends about 4 hours on math homework each week?

- 1) 62
- 2) 72
- 3) 82
- 4) 92

384 Mr. Turner bought x boxes of pencils. Each box holds 25 pencils. He left 3 boxes of pencils at home and took the rest to school. Which expression represents the total number of pencils he took to school?

- 1) $22x$
- 2) $25x - 3$
- 3) $25 - 3x$
- 4) $25x - 75$

Integrated Algebra Multiple Choice Regents Exam Questions

www.jmap.org

385 Carrie bought new carpet for her living room. She calculated the area of the living room to be 174.2 square feet. The actual area was 149.6 square feet. What is the relative error of the area to the *nearest ten-thousandth*?

- 1) 0.1412
- 2) 0.1644
- 3) 1.8588
- 4) 2.1644

386 An electronics store sells DVD players and cordless telephones. The store makes a \$75 profit on the sale of each DVD player (d) and a \$30 profit on the sale of each cordless telephone (c). The store wants to make a profit of at least \$255.00 from its sales of DVD players and cordless phones. Which inequality describes this situation?

- 1) $75d + 30c < 255$
- 2) $75d + 30c \leq 255$
- 3) $75d + 30c > 255$
- 4) $75d + 30c \geq 255$

387 Which ordered pair is in the solution set of the system of equations $y = -x + 1$ and $y = x^2 + 5x + 6$?

- 1) $(-5, -1)$
- 2) $(-5, 6)$
- 3) $(5, -4)$
- 4) $(5, 2)$

388 Which situation describes a correlation that is *not* a causal relationship?

- 1) The rooster crows, and the Sun rises.
- 2) The more miles driven, the more gasoline needed
- 3) The more powerful the microwave, the faster the food cooks.
- 4) The faster the pace of a runner, the quicker the runner finishes.

389 Which equation most closely represents the line of best fit for the scatter plot below?

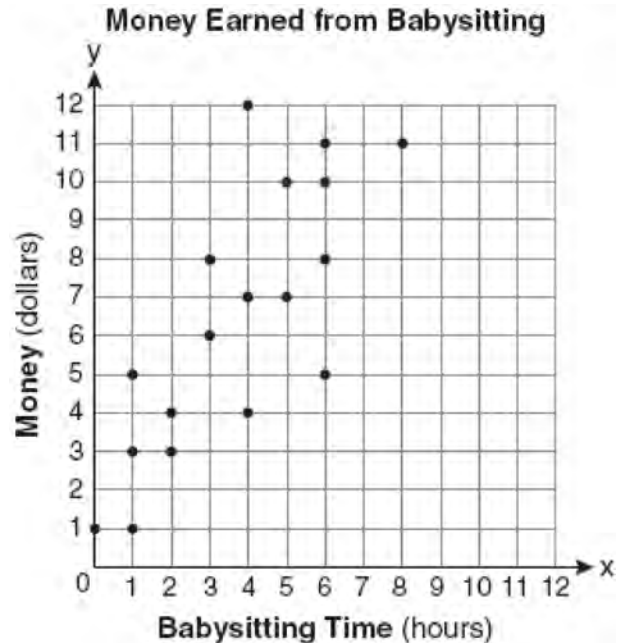

- 1) $y = x$
- 2) $y = \frac{2}{3}x + 1$
- 3) $y = \frac{3}{2}x + 4$
- 4) $y = \frac{3}{2}x + 1$

390 At Genesee High School, the sophomore class has 60 more students than the freshman class. The junior class has 50 fewer students than twice the students in the freshman class. The senior class is three times as large as the freshman class. If there are a total of 1,424 students at Genesee High School, how many students are in the freshman class?

- 1) 202
- 2) 205
- 3) 235
- 4) 236

Integrated Algebra Multiple Choice Regents Exam Questions

www.jmap.org

- 391 A cylindrical container has a diameter of 12 inches and a height of 15 inches, as illustrated in the diagram below.

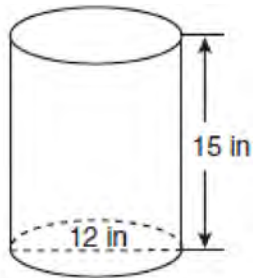

(Not drawn to scale)

What is the volume of this container to the *nearest tenth* of a cubic inch?

- 1) 6,785.8
 2) 4,241.2
 3) 2,160.0
 4) 1,696.5
- 392 Consider the graph of the equation $y = ax^2 + bx + c$, when $a \neq 0$. If a is multiplied by 3, what is true of the graph of the resulting parabola?
- 1) The vertex is 3 units above the vertex of the original parabola.
 2) The new parabola is 3 units to the right of the original parabola.
 3) The new parabola is wider than the original parabola.
 4) The new parabola is narrower than the original parabola.
- 393 What are the roots of the equation $x^2 - 7x + 6 = 0$?
- 1) 1 and 7
 2) -1 and 7
 3) -1 and -6
 4) 1 and 6

- 394 The function $y = \frac{x}{x^2 - 9}$ is undefined when the value of x is
- 1) 0 or 3
 2) 3 or -3
 3) 3, only
 4) -3, only

- 395 When $3g^2 - 4g + 2$ is subtracted from $7g^2 + 5g - 1$, the difference is
- 1) $-4g^2 - 9g + 3$
 2) $4g^2 + g + 1$
 3) $4g^2 + 9g - 3$
 4) $10g^2 + g + 1$

- 396 In a linear equation, the independent variable increases at a constant rate while the dependent variable decreases at a constant rate. The slope of this line is
- 1) zero
 2) negative
 3) positive
 4) undefined

- 397 Erica is conducting a survey about the proposed increase in the sports budget in the Hometown School District. Which survey method would likely contain the most bias?
- 1) Erica asks every third person entering the Hometown Grocery Store.
 2) Erica asks every third person leaving the Hometown Shopping Mall this weekend.
 3) Erica asks every fifth student entering Hometown High School on Monday morning.
 4) Erica asks every fifth person leaving Saturday's Hometown High School football game.

Integrated Algebra Multiple Choice Regents Exam Questions

www.jmap.org

398 Pam is playing with red and black marbles. The number of red marbles she has is three more than twice the number of black marbles she has. She has 42 marbles in all. How many red marbles does Pam have?

- 1) 13
- 2) 15
- 3) 29
- 4) 33

399 Which graph represents a function?

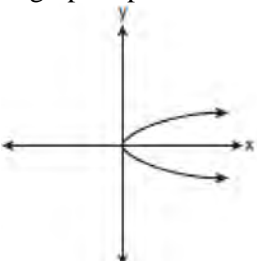
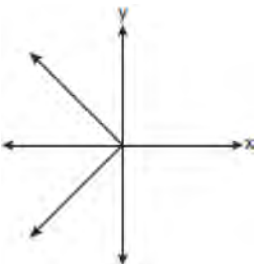
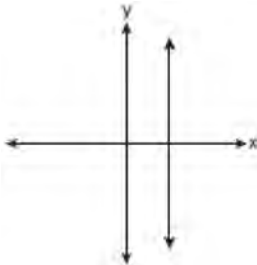
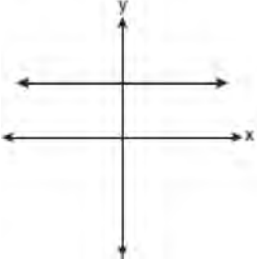
- 1) 
- 2) 
- 3) 
- 4) 

400 Which equation represents the axis of symmetry of the graph of the parabola below?

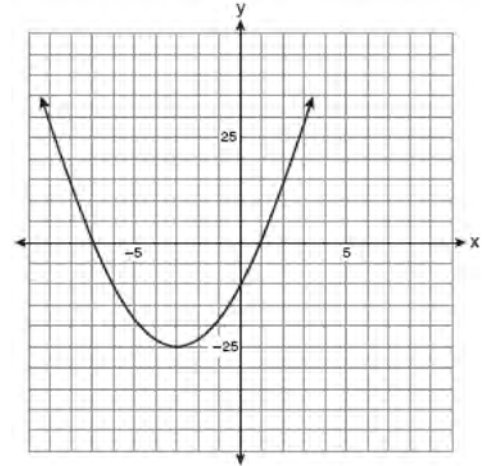

- 1) $y = -3$
- 2) $x = -3$
- 3) $y = -25$
- 4) $x = -25$

401 The sign shown below is posted in front of a roller coaster ride at the Wadsworth County Fairgrounds.

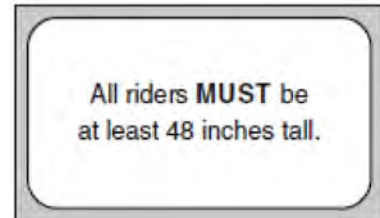

If h represents the height of a rider in inches, what is a correct translation of the statement on this sign?

- 1) $h < 48$
- 2) $h > 48$
- 3) $h \leq 48$
- 4) $h \geq 48$

Integrated Algebra Multiple Choice Regents Exam Questions

www.jmap.org

- 402 The data set 5, 6, 7, 8, 9, 9, 9, 10, 12, 14, 17, 17, 18, 19, 19 represents the number of hours spent on the Internet in a week by students in a mathematics class. Which box-and-whisker plot represents the data?

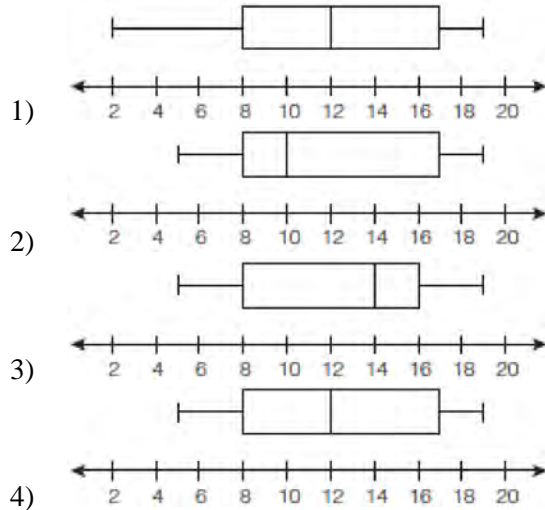

- 403 What is the product of $\frac{x^2 - 1}{x + 1}$ and $\frac{x + 3}{3x - 3}$ expressed in simplest form?
- 1) x
 - 2) $\frac{x}{3}$
 - 3) $x + 3$
 - 4) $\frac{x + 3}{3}$

- 404 What is the slope of the line containing the points (3,4) and (-6,10)?
- 1) $\frac{1}{2}$
 - 2) 2
 - 3) $-\frac{2}{3}$
 - 4) $-\frac{3}{2}$

- 405 If h represents a number, which equation is a correct translation of "Sixty more than 9 times a number is 375"?
- 1) $9h = 375$
 - 2) $9h + 60 = 375$
 - 3) $9h - 60 = 375$
 - 4) $60h + 9 = 375$

- 406 On a certain day in Toronto, Canada, the temperature was 15° Celsius (C). Using the formula $F = \frac{9}{5}C + 32$, Peter converts this temperature to degrees Fahrenheit (F). Which temperature represents 15° C in degrees Fahrenheit?
- 1) -9
 - 2) 35
 - 3) 59
 - 4) 85

- 407 The length of a rectangular room is 7 less than three times the width, w , of the room. Which expression represents the area of the room?
- 1) $3w - 4$
 - 2) $3w - 7$
 - 3) $3w^2 - 4w$
 - 4) $3w^2 - 7w$

- 408 The length of a rectangular window is 5 feet more than its width, w . The area of the window is 36 square feet. Which equation could be used to find the dimensions of the window?
- 1) $w^2 + 5w + 36 = 0$
 - 2) $w^2 - 5w - 36 = 0$
 - 3) $w^2 - 5w + 36 = 0$
 - 4) $w^2 + 5w - 36 = 0$

Integrated Algebra Multiple Choice Regents Exam Questions

www.jmap.org

- 409 A survey is being conducted to determine which types of television programs people watch. Which survey and location combination would likely contain the most bias?
- 1) surveying 10 people who work in a sporting goods store
 - 2) surveying the first 25 people who enter a grocery store
 - 3) randomly surveying 50 people during the day in a mall
 - 4) randomly surveying 75 people during the day in a clothing store

- 410 Luis is going to paint a basketball court on his driveway, as shown in the diagram below. This basketball court consists of a rectangle and a semicircle.

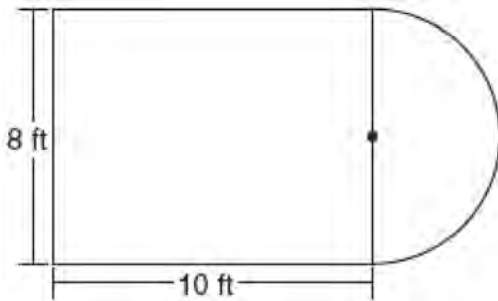

Which expression represents the area of this basketball court, in square feet?

- 1) 80
 - 2) $80 + 8\pi$
 - 3) $80 + 16\pi$
 - 4) $80 + 64\pi$
- 411 What is $\sqrt{72}$ expressed in simplest radical form?
- 1) $2\sqrt{18}$
 - 2) $3\sqrt{8}$
 - 3) $6\sqrt{2}$
 - 4) $8\sqrt{3}$

- 412 Rhonda has \$1.35 in nickels and dimes in her pocket. If she has six more dimes than nickels, which equation can be used to determine x , the number of nickels she has?

- 1) $0.05(x + 6) + 0.10x = 1.35$
- 2) $0.05x + 0.10(x + 6) = 1.35$
- 3) $0.05 + 0.10(6x) = 1.35$
- 4) $0.15(x + 6) = 1.35$

- 413 Students in Ms. Nazzeer's mathematics class tossed a six-sided number cube whose faces are numbered 1 to 6. The results are recorded in the table below.

Result	Frequency
1	3
2	6
3	4
4	6
5	4
6	7

Based on these data, what is the empirical probability of tossing a 4?

- 1) $\frac{8}{30}$
- 2) $\frac{6}{30}$
- 3) $\frac{5}{30}$
- 4) $\frac{1}{30}$

Integrated Algebra Multiple Choice Regents Exam Questions

www.jmap.org

414 What is half of 2^6 ?

- 1) 1^3
- 2) 1^6
- 3) 2^3
- 4) 2^5

415 There is a negative correlation between the number of hours a student watches television and his or her social studies test score. Which scatter plot below displays this correlation?

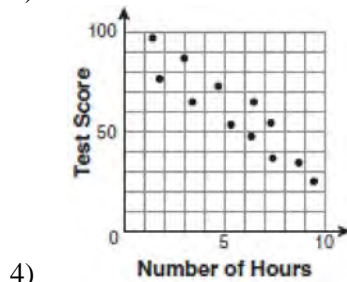
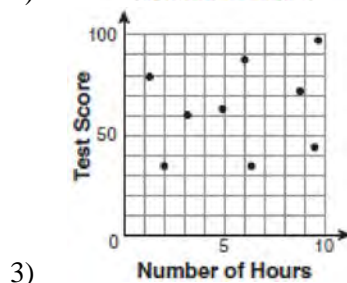
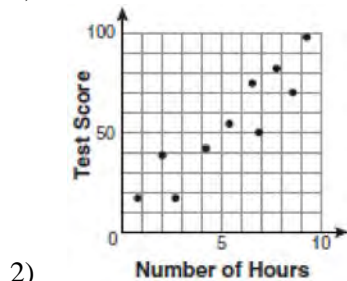
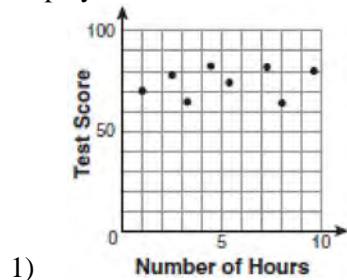

416 The bowling team at Lincoln High School must choose a president, vice president, and secretary. If the team has 10 members, which expression could be used to determine the number of ways the officers could be chosen?

- 1) ${}^3P_{10}$
- 2) 7P_3
- 3) ${}_{10}P_3$
- 4) ${}_{10}P_7$

417 An online music club has a one-time registration fee of \$13.95 and charges \$0.49 to buy each song. If Emma has \$50.00 to join the club and buy songs, what is the maximum number of songs she can buy?

- 1) 73
- 2) 74
- 3) 130
- 4) 131

418 Kathy plans to purchase a car that depreciates (loses value) at a rate of 14% per year. The initial cost of the car is \$21,000. Which equation represents the value, v , of the car after 3 years?

- 1) $v = 21,000(0.14)^3$
- 2) $v = 21,000(0.86)^3$
- 3) $v = 21,000(1.14)^3$
- 4) $v = 21,000(0.86)(3)$

419 When $5\sqrt{20}$ is written in simplest radical form, the result is $k\sqrt{5}$. What is the value of k ?

- 1) 20
- 2) 10
- 3) 7
- 4) 4

Integrated Algebra Multiple Choice Regents Exam Questions

www.jmap.org

420 What is the slope of the line that passes through the points (2,5) and (7,3)?

- 1) $-\frac{5}{2}$
- 2) $-\frac{2}{5}$
- 3) $\frac{8}{9}$
- 4) $\frac{9}{8}$

421 Which equation is represented by the graph below?

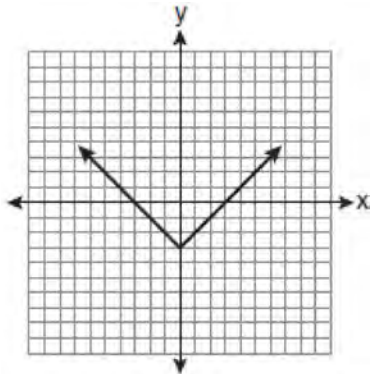

- 1) $y = x^2 - 3$
- 2) $y = (x - 3)^2$
- 3) $y = |x| - 3$
- 4) $y = |x - 3|$

422 Which value of n makes the expression $\frac{5n}{2n-1}$ undefined?

- 1) 1
- 2) 0
- 3) $-\frac{1}{2}$
- 4) $\frac{1}{2}$

423 Which relation is *not* a function?

- 1) $\{(1,5), (2,6), (3,6), (4,7)\}$
- 2) $\{(4,7), (2,1), (-3,6), (3,4)\}$
- 3) $\{(-1,6), (1,3), (2,5), (1,7)\}$
- 4) $\{(-1,2), (0,5), (5,0), (2,-1)\}$

424 Students in a ninth grade class measured their heights, h , in centimeters. The height of the shortest student was 155 cm, and the height of the tallest student was 190 cm. Which inequality represents the range of heights?

- 1) $155 < h < 190$
- 2) $155 \leq h \leq 190$
- 3) $h \geq 155$ or $h \leq 190$
- 4) $h > 155$ or $h < 190$

425 Which statement is true about the data set 3, 4, 5, 6, 7, 7, 10?

- 1) mean = mode
- 2) mean > mode
- 3) mean = median
- 4) mean < median

426 Which relationship can best be described as causal?

- 1) height and intelligence
- 2) shoe size and running speed
- 3) number of correct answers on a test and test score
- 4) number of students in a class and number of students with brown hair

Integrated Algebra Multiple Choice Regents Exam Questions

www.jmap.org

427 Which equation represents a line that is parallel to the line $y = 3 - 2x$?

- 1) $4x + 2y = 5$
- 2) $2x + 4y = 1$
- 3) $y = 3 - 4x$
- 4) $y = 4x - 2$

428 Which inequality is represented by the graph below?

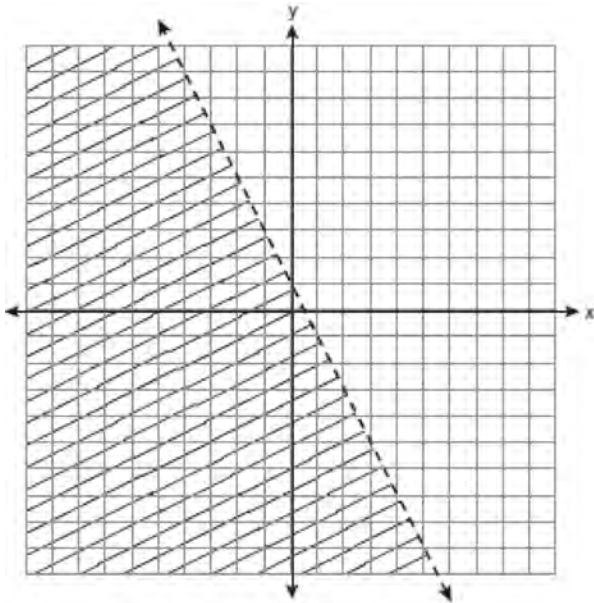

- 1) $y < 2x + 1$
- 2) $y < -2x + 1$
- 3) $y < \frac{1}{2}x + 1$
- 4) $y < -\frac{1}{2}x + 1$

429 A movie theater recorded the number of tickets sold daily for a popular movie during the month of June. The box-and-whisker plot shown below represents the data for the number of tickets sold, in hundreds.

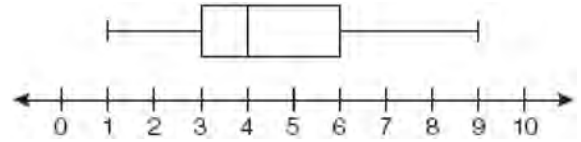

Which conclusion can be made using this plot?

- 1) The second quartile is 600.
- 2) The mean of the attendance is 400.
- 3) The range of the attendance is 300 to 600.
- 4) Twenty-five percent of the attendance is between 300 and 400.

430 It takes Tammy 45 minutes to ride her bike 5 miles. At this rate, how long will it take her to ride 8 miles?

- 1) 0.89 hour
- 2) 1.125 hours
- 3) 48 minutes
- 4) 72 minutes

431 Which expression represents $\frac{(2x^3)(8x^5)}{4x^6}$ in simplest form?

- 1) x^2
- 2) x^9
- 3) $4x^2$
- 4) $4x^9$

Integrated Algebra Multiple Choice Regents Exam Questions

www.jmap.org

- 432 The set $\{1, 2, 3, 4\}$ is equivalent to
- 1) $\{x \mid 1 < x < 4, \text{ where } x \text{ is a whole number}\}$
 - 2) $\{x \mid 0 < x < 4, \text{ where } x \text{ is a whole number}\}$
 - 3) $\{x \mid 0 < x \leq 4, \text{ where } x \text{ is a whole number}\}$
 - 4) $\{x \mid 1 < x \leq 4, \text{ where } x \text{ is a whole number}\}$

433 What is the solution of $\frac{k+4}{2} = \frac{k+9}{3}$?

- 1) 1
- 2) 5
- 3) 6
- 4) 14

434 If the formula for the perimeter of a rectangle is $P = 2l + 2w$, then w can be expressed as

- 1) $w = \frac{2l - P}{2}$
- 2) $w = \frac{P - 2l}{2}$
- 3) $w = \frac{P - l}{2}$
- 4) $w = \frac{P - 2w}{2l}$

435 Which value of x is the solution of

$$\frac{2x}{5} + \frac{1}{3} = \frac{7x - 2}{15}?$$

- 1) $\frac{3}{5}$
- 2) $\frac{31}{26}$
- 3) 3
- 4) 7

- 436 Keisha is playing a game using a wheel divided into eight equal sectors, as shown in the diagram below. Each time the spinner lands on orange, she will win a prize.

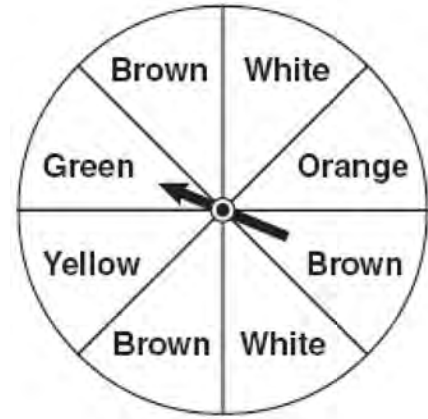

If Keisha spins this wheel twice, what is the probability she will win a prize on *both* spins?

- 1) $\frac{1}{64}$
- 2) $\frac{1}{56}$
- 3) $\frac{1}{16}$
- 4) $\frac{1}{4}$

437 Which equation represents a line parallel to the x -axis?

- 1) $x = 5$
- 2) $y = 10$
- 3) $x = \frac{1}{3}y$
- 4) $y = 5x + 17$

Integrated Algebra Multiple Choice Regents Exam Questions

www.jmap.org

438 Which value of x is the solution of the equation

$$\frac{2x}{3} + \frac{x}{6} = 5?$$

- 1) 6
- 2) 10
- 3) 15
- 4) 30

439 Alex earned scores of 60, 74, 82, 87, 87, and 94 on his first six algebra tests. What is the relationship between the measures of central tendency of these scores?

- 1) median < mode < mean
- 2) mean < mode < median
- 3) mode < median < mean
- 4) mean < median < mode

440 Which value of p is the solution of

$$5p - 1 = 2p + 20?$$

- 1) $\frac{19}{7}$
- 2) $\frac{19}{3}$
- 3) 3
- 4) 7

441 To calculate the volume of a small wooden cube, Ezra measured an edge of the cube as 2 cm. The actual length of the edge of Ezra's cube is 2.1 cm. What is the relative error in his volume calculation to the nearest hundredth?

- 1) 0.13
- 2) 0.14
- 3) 0.15
- 4) 0.16

442 Which value of x makes the expression

$$\frac{x^2 - 9}{x^2 + 7x + 10} \text{ undefined?}$$

- 1) -5
- 2) 2
- 3) 3
- 4) -3

443 What is $\frac{6}{4a} - \frac{2}{3a}$ expressed in simplest form?

- 1) $\frac{4}{a}$
- 2) $\frac{5}{6a}$
- 3) $\frac{8}{7a}$
- 4) $\frac{10}{12a}$

444 What is the additive inverse of the expression $a - b$?

- 1) $a + b$
- 2) $a - b$
- 3) $-a + b$
- 4) $-a - b$

445 Sam and Odel have been selling frozen pizzas for a class fundraiser. Sam has sold half as many pizzas as Odel. Together they have sold a total of 126 pizzas. How many pizzas did Sam sell?

- 1) 21
- 2) 42
- 3) 63
- 4) 84

Integrated Algebra Multiple Choice Regents Exam Questions

www.jmap.org

- 446 Which statement is true about the relation shown on the graph below?

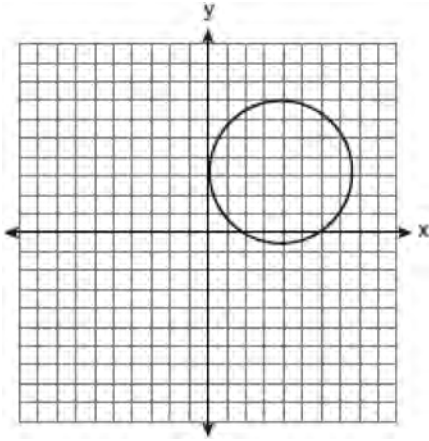

- 1) It is a function because there exists one x -coordinate for each y -coordinate.
- 2) It is a function because there exists one y -coordinate for each x -coordinate.
- 3) It is *not* a function because there are multiple y -values for a given x -value.
- 4) It is *not* a function because there are multiple x -values for a given y -value.

- 447 Which expression represents $\frac{25x - 125}{x^2 - 25}$ in simplest form?

- 1) $\frac{5}{x}$
- 2) $\frac{-5}{x}$
- 3) $\frac{25}{x-5}$
- 4) $\frac{25}{x+5}$

- 448 Which value of x makes the expression $\frac{x+4}{x-3}$ undefined?

- 1) -4
- 2) -3
- 3) 3
- 4) 0

- 449 Marie currently has a collection of 58 stamps. If she buys s stamps each week for w weeks, which expression represents the total number of stamps she will have?

- 1) $58sw$
- 2) $58 + sw$
- 3) $58s + w$
- 4) $58 + s + w$

- 450 Which expression represents $\frac{x^2 - 2x - 15}{x^2 + 3x}$ in simplest form?

- 1) -5
- 2) $\frac{x-5}{x}$
- 3) $\frac{-2x-5}{x}$
- 4) $\frac{-2x-15}{3x}$

Integrated Algebra 2 Point Regents Exam Questions

451 Simplify: $\frac{27k^5m^8}{(4k^3)(9m^2)}$

- 452 A designer created the logo shown below. The logo consists of a square and four quarter-circles of equal size.

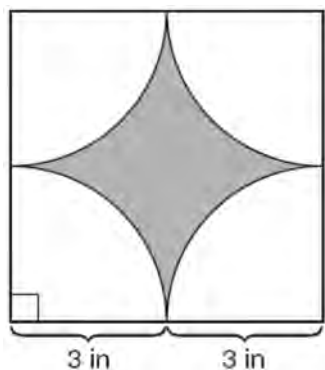

Express, in terms of π , the exact area, in square inches, of the shaded region.

453 Express in simplest form: $\frac{45a^4b^3 - 90a^3b}{15a^2b}$

- 454 Determine how many three-letter arrangements are possible with the letters $A, N, G, L,$ and E if no letter may be repeated.

455 Perform the indicated operation: $-6(a - 7)$
 State the name of the property used.

456 Solve for c in terms of a and b : $bc + ac = ab$

- 457 Maureen tracks the range of outdoor temperatures over three days. She records the following information.

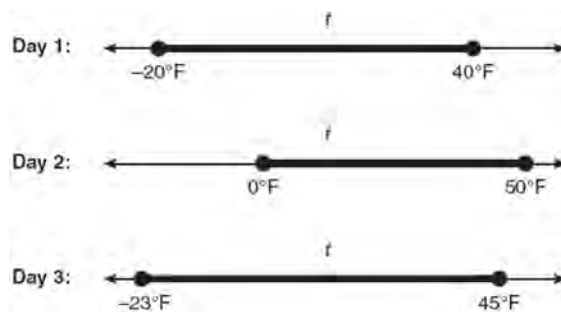

Express the intersection of the three sets as an inequality in terms of temperature, t .

- 458 Three storage bins contain colored blocks. Bin 1 contains 15 red and 14 blue blocks. Bin 2 contains 16 white and 15 blue blocks. Bin 3 contains 15 red and 15 white blocks. All of the blocks from the three bins are placed into one box. If one block is randomly selected from the box, which color block would most likely be picked? Justify your answer.

- 459 Some books are laid on a desk. Two are English, three are mathematics, one is French, and four are social studies. Theresa selects an English book and Isabelle then selects a social studies book. Both girls take their selections to the library to read. If Truman then selects a book at random, what is the probability that he selects an English book?

Integrated Algebra 2 Point Regents Exam Questions

www.jmap.org

- 460 Factor completely: $4x^3 - 36x$
- 461 Alexis calculates the surface area of a gift box as 600 square inches. The actual surface area of the gift box is 592 square inches. Find the relative error of Alexis' calculation expressed as a decimal to the *nearest thousandth*.
- 462 Casey purchased a pack of assorted flower seeds and planted them in her garden. When the first 25 flowers bloomed, 11 were white, 5 were red, 3 were blue, and the rest were yellow. Find the empirical probability that a flower that blooms will be yellow.
- 463 Joseph typed a 1,200-word essay in 25 minutes. At this rate, determine how many words he can type in 45 minutes.
- 464 In right triangle ABC , $AB = 20$, $AC = 12$, $BC = 16$, and $m\angle C = 90$. Find, to the *nearest degree*, the measure of $\angle A$.
- 465 The length and width of the base of a rectangular prism are 5.5 cm and 3 cm. The height of the prism is 6.75 cm. Find the *exact* value of the surface area of the prism, in square centimeters.

466 Solve for g : $3 + 2g = 5g - 9$

- 467 Tom drove 290 miles from his college to home and used 23.2 gallons of gasoline. His sister, Ann, drove 225 miles from her college to home and used 15 gallons of gasoline. Whose vehicle had better gas mileage? Justify your answer.
- 468 The table below represents the number of hours a student worked and the amount of money the student earned.

Number of Hours (h)	Dollars Earned (d)
8	\$50.00
15	\$93.75
19	\$118.75
30	\$187.50

Write an equation that represents the number of dollars, d , earned in terms of the number of hours, h , worked. Using this equation, determine the number of dollars the student would earn for working 40 hours.

- 469 A method for solving $5(x - 2) - 2(x - 5) = 9$ is shown below. Identify the property used to obtain each of the two indicated steps.

$$5(x - 2) - 2(x - 5) = 9$$

(1) $5x - 10 - 2x + 10 = 9$ (1) _____

(2) $5x - 2x - 10 + 10 = 9$ (2) _____

$$3x + 0 = 9$$

$$3x = 9$$

$$x = 3$$

470 Roberta needs ribbon for a craft project. The ribbon sells for \$3.75 per yard. Find the cost, in dollars, for 48 inches of the ribbon.

471 A window is made up of a single piece of glass in the shape of a semicircle and a rectangle, as shown in the diagram below. Tess is decorating for a party and wants to put a string of lights all the way around the outside edge of the window.

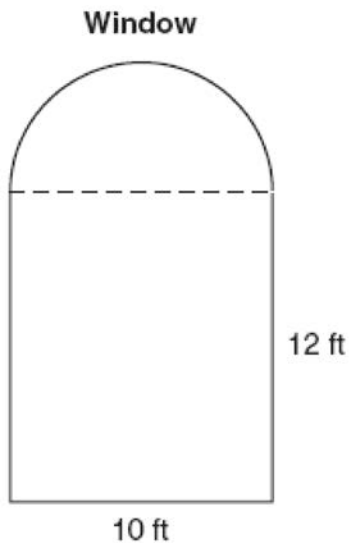

To the *nearest foot*, what is the length of the string of lights that Tess will need to decorate the window?

472 Express the product of $\frac{x+2}{2}$ and $\frac{4x+20}{x^2+6x+8}$ in simplest form.

473 Express $-3\sqrt{48}$ in simplest radical form.

474 As shown in the diagram below, a ladder 5 feet long leans against a wall and makes an angle of 65° with the ground. Find, to the *nearest tenth of a foot*, the distance from the wall to the base of the ladder.

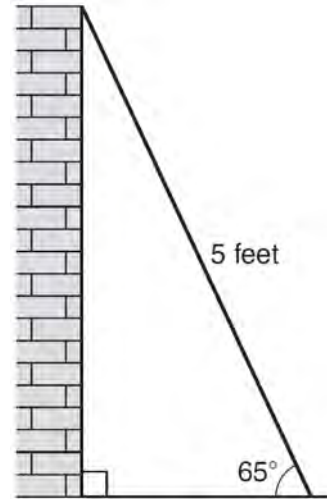

475 On the set of axes below, graph $y = 3^x$ over the interval $-1 \leq x \leq 2$.

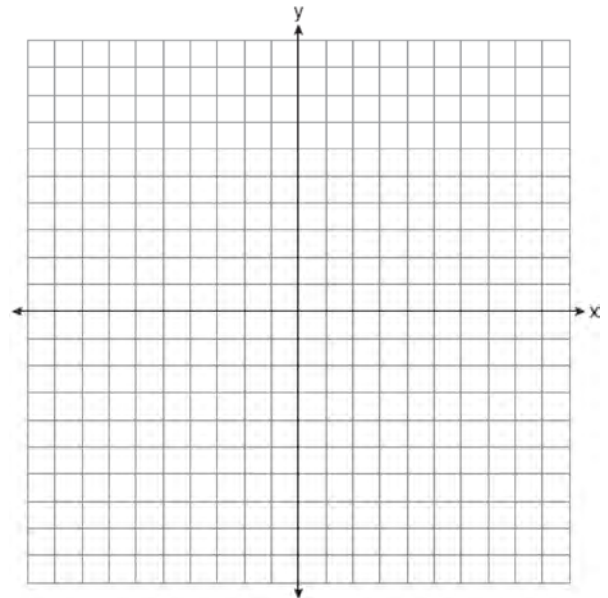

476 Jon is buying tickets for himself for two concerts. For the jazz concert, 4 tickets are available in the front row, and 32 tickets are available in the other rows. For the orchestra concert, 3 tickets are available in the front row, and 23 tickets are available in the other rows. Jon is randomly assigned one ticket for each concert. Determine the concert for which he is more likely to get a front-row ticket. Justify your answer.

477 State the equation of the axis of symmetry and the coordinates of the vertex of the parabola graphed below.

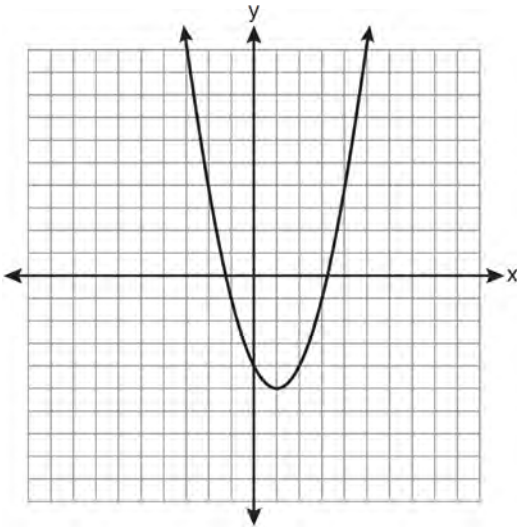

478 The area of a rectangle is represented by $x^2 - 5x - 24$. If the width of the rectangle is represented by $x - 8$, express the length of the rectangle as a binomial.

479 Express $5\sqrt{72}$ in simplest radical form.

480 In a game of ice hockey, the hockey puck took 0.8 second to travel 89 feet to the goal line. Determine the average speed of the puck in feet per second.

481 Ms. Hopkins recorded her students' final exam scores in the frequency table below.

Interval	Tally	Frequency
61–70	###	5
71–80		4
81–90	###	9
91–100	###	6

On the grid below, construct a frequency histogram based on the table.

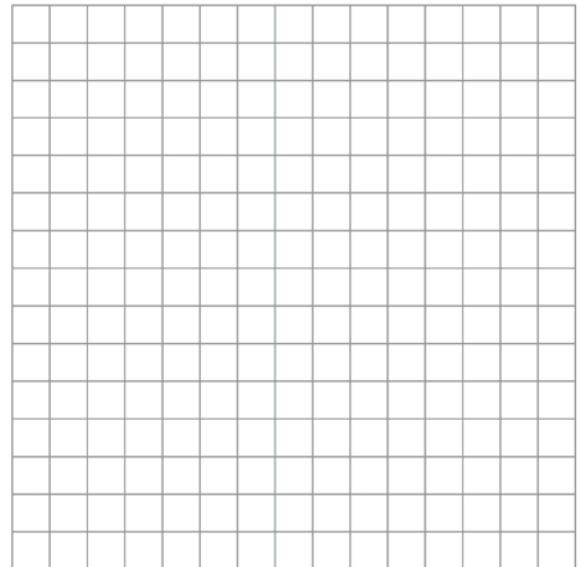

482 Students calculated the area of a playing field to be 8,100 square feet. The actual area of the field is 7,678.5 square feet. Find the relative error in the area, to the *nearest thousandth*.

- 483 The square dart board shown below has a side that measures 40 inches. The shaded portion in the center is a square whose side is 15 inches. A dart thrown at the board is equally likely to land on any point on the dartboard.

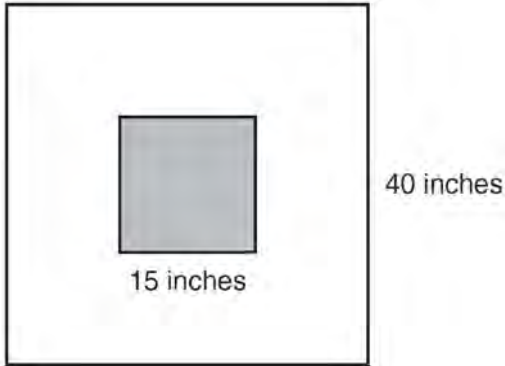

Find the probability that a dart hitting the board will *not* land in the shaded area.

- 484 Express in simplest form: $\frac{x^2 - 1}{x^2 + 3x + 2}$

- 485 Clayton has three fair coins. Find the probability that he gets two tails and one head when he flips the three coins.

- 486 Angela wants to purchase carpeting for her living room. The dimensions of her living room are 12 feet by 12 feet. If carpeting is sold by the square yard, determine how many square yards of carpeting she must purchase.

$3 \text{ feet} = 1 \text{ yard}$ $9 \text{ square feet} = 1 \text{ square yard}$

- 487 Solve the following system of equations algebraically for y :

$$2x + 2y = 9$$

$$2x - y = 3$$

- 488 State the value of the expression $\frac{(4.1 \times 10^2)(2.4 \times 10^3)}{(1.5 \times 10^7)}$ in scientific notation.

- 489 Brianna is using the two spinners shown below to play her new board game. She spins the arrow on each spinner once. Brianna uses the first spinner to determine how many spaces to move. She uses the second spinner to determine whether her move from the first spinner will be forward or backward.

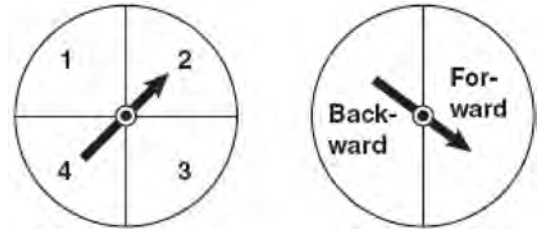

Find the probability that Brianna will move *fewer than* four spaces and *backward*.

- 490 Mrs. Chen owns two pieces of property. The areas of the properties are 77,120 square feet and 33,500 square feet.

$43,560 \text{ square feet} = 1 \text{ acre}$

Find the total number of acres Mrs. Chen owns, to the *nearest hundredth of an acre*.

- 491 Twelve players make up a high school basketball team. The team jerseys are numbered 1 through 12. The players wearing the jerseys numbered 3, 6, 7, 8, and 11 are the only players who start a game. Using set notation, list the complement of this subset.

- 492 Serena's garden is a rectangle joined with a semicircle, as shown in the diagram below. Line segment AB is the diameter of semicircle P . Serena wants to put a fence around her garden.

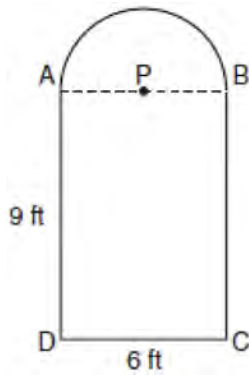

Calculate the length of fence Serena needs to the nearest tenth of a foot.

- 493 The diagram below represents Joe's two fish tanks.

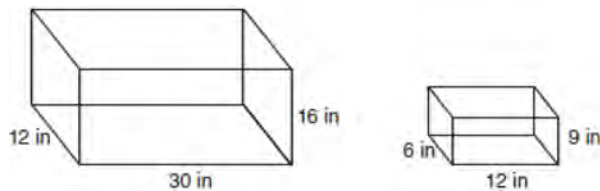

Joe's larger tank is completely filled with water. He takes water from it to completely fill the small tank. Determine how many cubic inches of water will remain in the larger tank.

- 494 Chad complained to his friend that he had five equations to solve for homework. Are all of the homework problems equations? Justify your answer.

Math Homework

1. $3x^2 \cdot 2x^4$
2. $5 - 2x = 3x$
3. $3(2x + 7)$
4. $7x^2 + 2x - 3x^2 - 9$
5. $\frac{2}{3} = \frac{x+2}{6}$

Name Chad

- 495 A communications company is building a 30-foot antenna to carry cell phone transmissions. As shown in the diagram below, a 50-foot wire from the top of the antenna to the ground is used to stabilize the antenna.

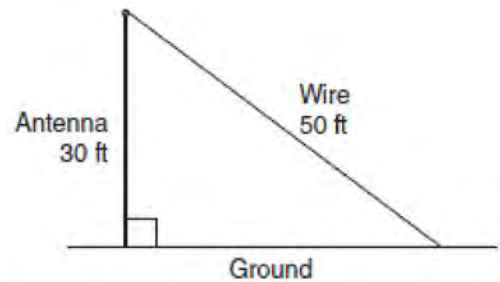

Find, to the nearest degree, the measure of the angle that the wire makes with the ground.

Integrated Algebra 3 Point Regents Exam Questions

- 496 Graph the equation $y = x^2 - 2x - 3$ on the accompanying set of axes. Using the graph, determine the roots of the equation $x^2 - 2x - 3 = 0$.

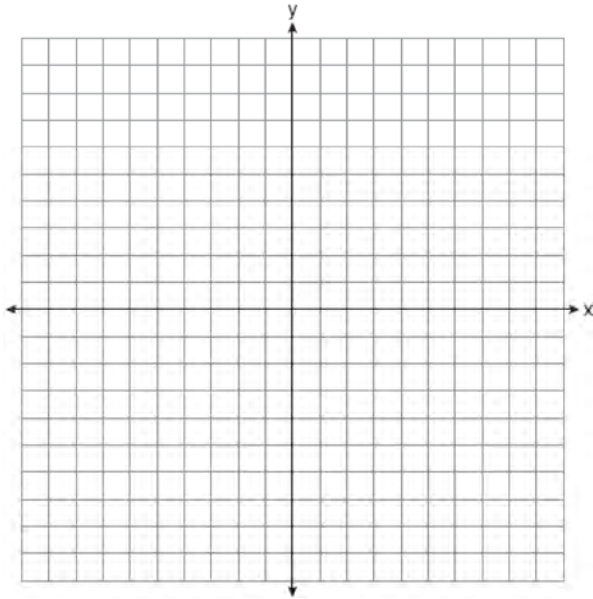

- 497 Sarah measures her rectangular bedroom window for a new shade. Her measurements are 36 inches by 42 inches. The actual measurements of the window are 36.5 inches and 42.5 inches. Using the measurements that Sarah took, determine the number of square inches in the area of the window. Determine the number of square inches in the actual area of the window. Determine the relative error in calculating the area. Express your answer as a decimal to the *nearest thousandth*.

- 498 A plastic storage box in the shape of a rectangular prism has a length of $x + 3$, a width of $x - 4$, and a height of 5. Represent the surface area of the box as a trinomial in terms of x .

- 499 The Hudson Record Store is having a going-out-of-business sale. CDs normally sell for \$18.00. During the first week of the sale, all CDs will sell for \$15.00. Written as a fraction, what is the rate of discount? What is this rate expressed as a percent? Round your answer to the *nearest hundredth of a percent*. During the second week of the sale, the same CDs will be on sale for 25% off the *original price*. What is the price of a CD during the second week of the sale?

- 500 A bank is advertising that new customers can open a savings account with a $3\frac{3}{4}\%$ interest rate compounded annually. Robert invests \$5,000 in an account at this rate. If he makes no additional deposits or withdrawals on his account, find the amount of money he will have, to the *nearest cent*, after three years.

- 501 Express $\frac{16\sqrt{21}}{2\sqrt{7}} - 5\sqrt{12}$ in simplest radical form.

- 502 The chart below compares two runners.

Runner	Distance, in miles	Time, in hours
Greg	11	2
Dave	16	3

Based on the information in this chart, state which runner has the faster rate. Justify your answer.

503 A trapezoid is shown below.

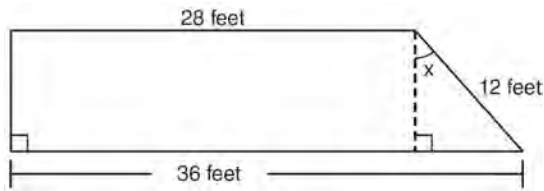

Calculate the measure of angle x , to the *nearest tenth of a degree*.

504 A prom ticket at Smith High School is \$120. Tom is going to save money for the ticket by walking his neighbor's dog for \$15 per week. If Tom already has saved \$22, what is the minimum number of weeks Tom must walk the dog to earn enough to pay for the prom ticket?

505 Ashley measured the dimensions of a rectangular prism to be 6 cm by 10 cm by 1.5 cm. The actual dimensions are 5.9 cm by 10.3 cm by 1.7 cm. Determine the relative error, to the *nearest thousandth*, in calculating the volume of the prism.

506 A 28-foot ladder is leaning against a house. The bottom of the ladder is 6 feet from the base of the house. Find the measure of the angle formed by the ladder and the ground, to the *nearest degree*.

507 Megan and Bryce opened a new store called the Donut Pit. Their goal is to reach a profit of \$20,000 in their 18th month of business. The table and scatter plot below represent the profit, P , in thousands of dollars, that they made during the first 12 months.

t (months)	P (profit, in thousands of dollars)
1	3.0
2	2.5
3	4.0
4	5.0
5	6.5
6	5.5
7	7.0
8	6.0
9	7.5
10	7.0
11	9.0
12	9.5

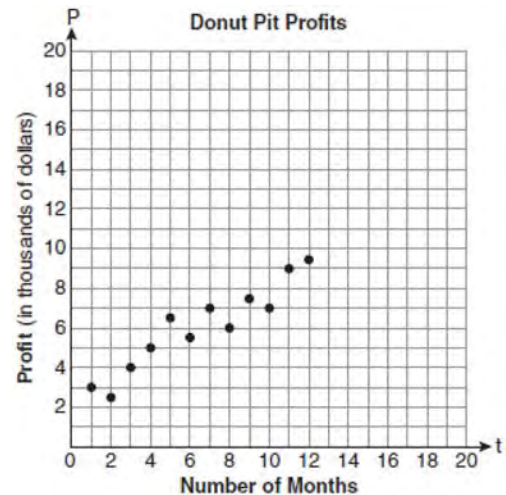

Draw a reasonable line of best fit. Using the line of best fit, predict whether Megan and Bryce will reach their goal in the 18th month of their business. Justify your answer.

508 Express $\frac{3\sqrt{75} + \sqrt{27}}{3}$ in simplest radical form.

- 509 The following cumulative frequency histogram shows the distances swimmers completed in a recent swim test.

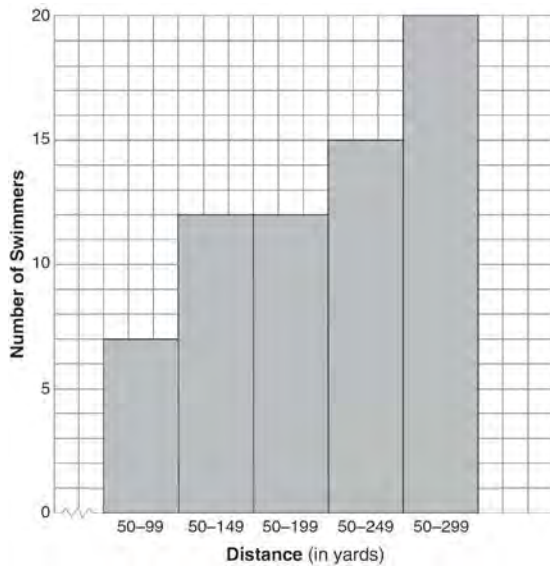

Based on the cumulative frequency histogram, determine the number of swimmers who swam between 200 and 249 yards. Determine the number of swimmers who swam between 150 and 199 yards. Determine the number of swimmers who took the swim test.

- 510 Given the following list of students' scores on a quiz:

5, 12, 7, 15, 20, 14, 7

Determine the median of these scores. Determine the mode of these scores. The teacher decides to adjust these scores by adding three points to each score. Explain the effect, if any, that this will have on the median and mode of these scores.

- 511 Find the roots of the equation $x^2 - x = 6$ algebraically.

- 512 In the diagram below, the circumference of circle O is 16π inches. The length of \overline{BC} is three-quarters of the length of diameter \overline{AD} and $CE = 4$ inches. Calculate the area, in square inches, of trapezoid $ABCD$.

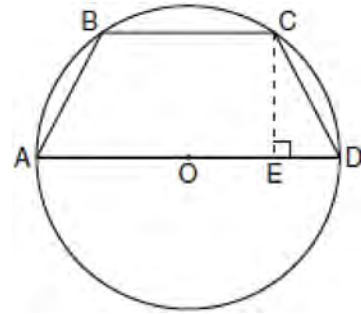

- 513 Find algebraically the equation of the axis of symmetry and the coordinates of the vertex of the parabola whose equation is $y = -2x^2 - 8x + 3$.

- 514 Solve algebraically for x : $2(x - 4) \geq \frac{1}{2}(5 - 3x)$

- 515 Solve algebraically for x : $\frac{x+2}{6} = \frac{3}{x-1}$

- 516 Perform the indicated operation and simplify:

$$\frac{3x+6}{4x+12} \div \frac{x^2-4}{x+3}$$

517 Find the roots of the equation $x^2 = 30 - 13x$ algebraically.

518 The table below shows the number of prom tickets sold over a ten-day period.

Prom Ticket Sales

Day (x)	1	2	5	7	10
Number of Prom Tickets Sold (y)	30	35	55	60	70

Plot these data points on the coordinate grid below. Use a consistent and appropriate scale. Draw a reasonable line of best fit and write its equation.

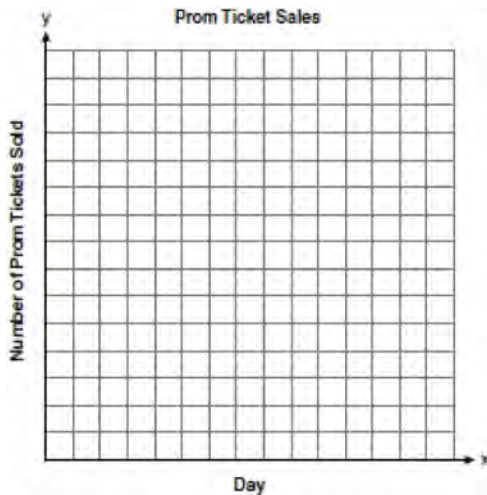

519 A soup can is in the shape of a cylinder. The can has a volume of 342 cm^3 and a diameter of 6 cm. Express the height of the can in terms of π . Determine the maximum number of soup cans that can be stacked on their base between two shelves if the distance between the shelves is exactly 36 cm. Explain your answer.

520 Mr. Laub has three children: two girls (Sue and Karen) and one boy (David). After each meal, one child is chosen at random to wash dishes. If the same child can be chosen for both lunch and dinner, construct a tree diagram or list a sample space of all the possible outcomes of who will wash dishes after lunch and dinner on Saturday. Determine the probability that one boy and one girl will wash dishes after lunch and dinner on Saturday.

521 Graph and label the following equations on the set of axes below.

$$y = |x|$$

$$y = \left| \frac{1}{2}x \right|$$

Explain how *decreasing* the coefficient of x affects the graph of the equation $y = |x|$.

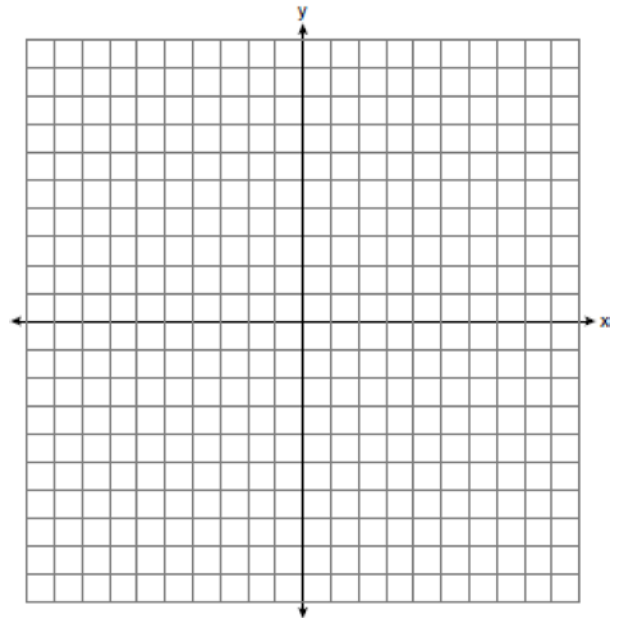

- 522 On the set of axes below, solve the following system of equations graphically. State the coordinates of the solution.

$$y = 4x - 1$$

$$2x + y = 5$$

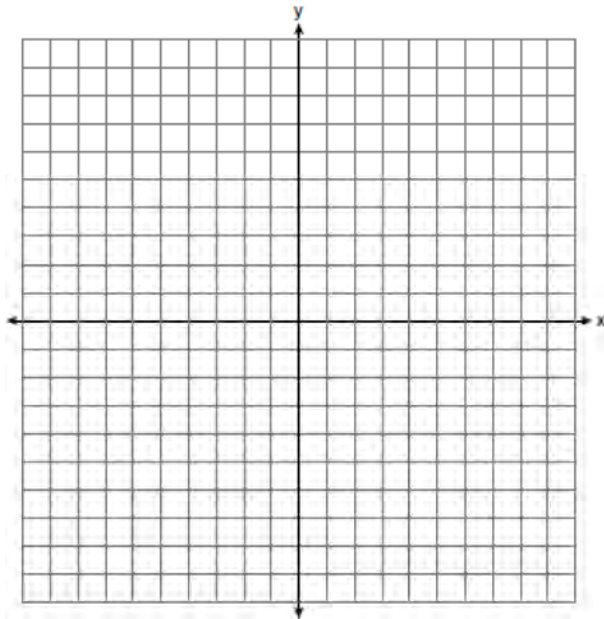

- 523 At the end of week one, a stock had increased in value from \$5.75 a share to \$7.50 a share. Find the percent of increase at the end of week one to the *nearest tenth of a percent*. At the end of week two, the same stock had decreased in value from \$7.50 to \$5.75. Is the percent of decrease at the end of week two the same as the percent of increase at the end of week one? Justify your answer.

- 524 Using his ruler, Howell measured the sides of a rectangular prism to be 5 cm by 8 cm by 4 cm. The actual measurements are 5.3 cm by 8.2 cm by 4.1 cm. Find Howell's relative error in calculating the volume of the prism, to the *nearest thousandth*.

- 525 The test scores for 18 students in Ms. Mosher's class are listed below:

86, 81, 79, 71, 58, 87, 52, 71, 87,
 87, 93, 64, 94, 81, 76, 98, 94, 68

Complete the frequency table below.

Interval	Tally	Frequency
51–60		
61–70		
71–80		
81–90		
91–100		

Draw and label a frequency histogram on the grid below.

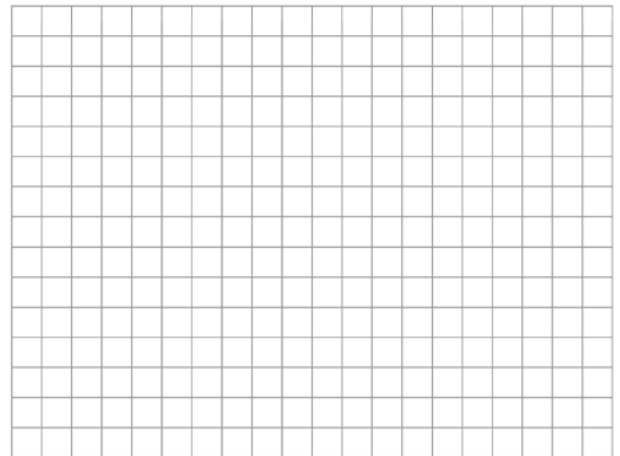

- 526 A turtle and a rabbit are in a race to see who is first to reach a point 100 feet away. The turtle travels at a constant speed of 20 feet per minute for the entire 100 feet. The rabbit travels at a constant speed of 40 feet per minute for the first 50 feet, stops for 3 minutes, and then continues at a constant speed of 40 feet per minute for the last 50 feet. Determine which animal won the race and by how much time.

- 527 On the set of axes below, graph the equation $y = x^2 + 2x - 8$. Using the graph, determine and state the roots of the equation $x^2 + 2x - 8 = 0$.

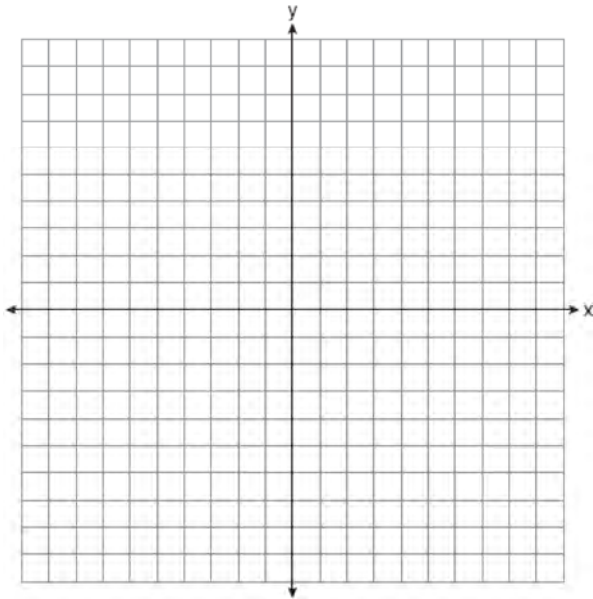

- 529 On the set of axes below, draw the graph of $y = 2^x$ over the interval $-1 \leq x \leq 3$. Will this graph ever intersect the x -axis? Justify your answer.

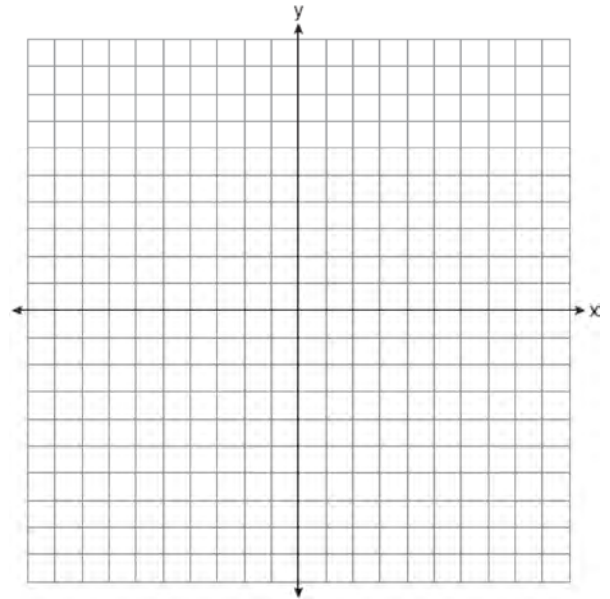

- 528 Ms. Mosher recorded the math test scores of six students in the table below.

Student	Student Score
Andrew	72
John	80
George	85
Amber	93
Betty	78
Roberto	80

Determine the mean of the student scores, to the nearest tenth. Determine the median of the student scores. Describe the effect on the mean and the median if Ms. Mosher adds 5 bonus points to each of the six students' scores.

- 530 Hannah took a trip to visit her cousin. She drove 120 miles to reach her cousin's house and the same distance back home. It took her 1.2 hours to get halfway to her cousin's house. What was her average speed, in miles per hour, for the first 1.2 hours of the trip? Hannah's average speed for the remainder of the trip to her cousin's house was 40 miles per hour. How long, in hours, did it take her to drive the remaining distance? Traveling home along the same route, Hannah drove at an average rate of 55 miles per hour. After 2 hours her car broke down. How many miles was she from home?

- 531 Given: $A = \{18, 6, -3, -12\}$
 Determine all elements of set A that are in the solution of the inequality $\frac{2}{3}x + 3 < -2x - 7$.

532 A line having a slope of $\frac{3}{4}$ passes through the point $(-8,4)$. Write the equation of this line in slope-intercept form.

533 On the set of axes below, graph and label the equations $y = |x|$ and $y = 3|x|$ for the interval $-3 \leq x \leq 3$.

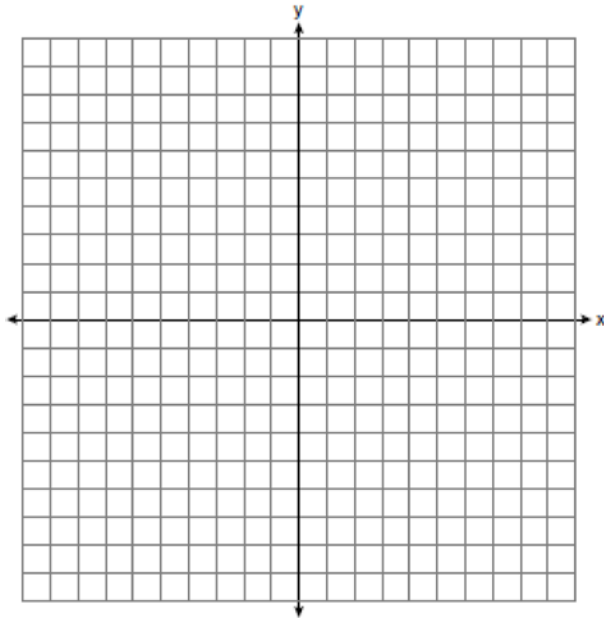

Explain how changing the coefficient of the absolute value from 1 to 3 affects the graph.

534 Peter begins his kindergarten year able to spell 10 words. He is going to learn to spell 2 new words every day. Write an inequality that can be used to determine how many days, d , it takes Peter to be able to spell *at least* 75 words. Use this inequality to determine the minimum number of whole days it will take for him to be able to spell *at least* 75 words.

535 The number of songs fifteen students have on their MP3 players is:

120, 124, 132, 145, 200, 255, 260, 292,
 308, 314, 342, 407, 421, 435, 452

State the values of the minimum, 1st quartile, median, 3rd quartile, and maximum. Using these values, construct a box-and-whisker plot using an appropriate scale on the line below.



536 Solve the following system of equations algebraically for *all* values of x and y .

$$y = x^2 + 2x - 8$$

$$y = 2x + 1$$

537 Chelsea has \$45 to spend at the fair. She spends \$20 on admission and \$15 on snacks. She wants to play a game that costs \$0.65 per game. Write an inequality to find the maximum number of times, x , Chelsea can play the game. Using this inequality, determine the maximum number of times she can play the game.

538 Find the volume, in cubic centimeters, *and* the surface area, in square centimeters, of the rectangular prism shown below.

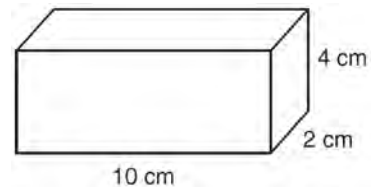

Integrated Algebra 3 Point Regents Exam Questions
www.jmap.org

539 Write an equation that represents the line that passes through the points $(5,4)$ and $(-5,0)$.

540 Express the product of $3\sqrt{20}(2\sqrt{5} - 7)$ in simplest radical form.

Integrated Algebra 4 Point Regents Exam Questions

- 541 On the set of axes below, graph the following system of inequalities and state the coordinates of a point in the solution set.

$$2x - y \geq 6$$

$$x > 2$$

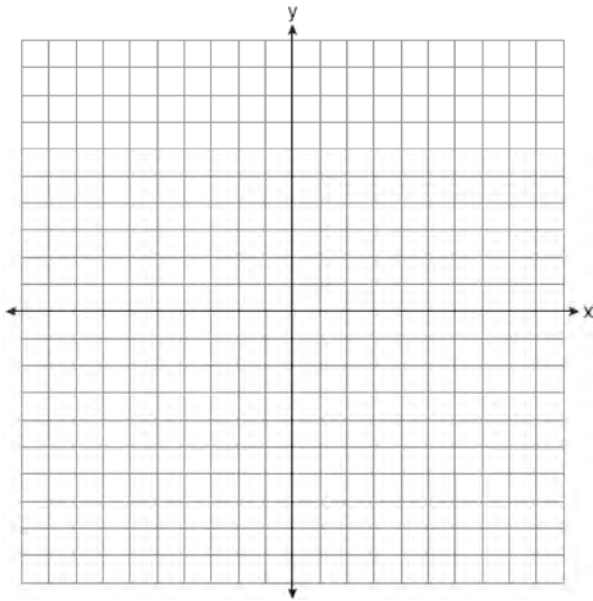

- 542 Sophie measured a piece of paper to be 21.7 cm by 28.5 cm. The piece of paper is actually 21.6 cm by 28.4 cm. Determine the number of square centimeters in the area of the piece of paper using Sophie's measurements. Determine the number of square centimeters in the actual area of the piece of paper. Determine the relative error in calculating the area. Express your answer as a decimal to the nearest thousandth. Sophie does not think there is a significant amount of error. Do you agree or disagree? Justify your answer.

- 543 Solve for m : $\frac{m}{5} + \frac{3(m-1)}{2} = 2(m-3)$

- 544 On the set of axes below, solve the following system of inequalities graphically.

$$y < 2x + 1$$

$$y \geq -\frac{1}{3}x + 4$$

State the coordinates of a point in the solution set.

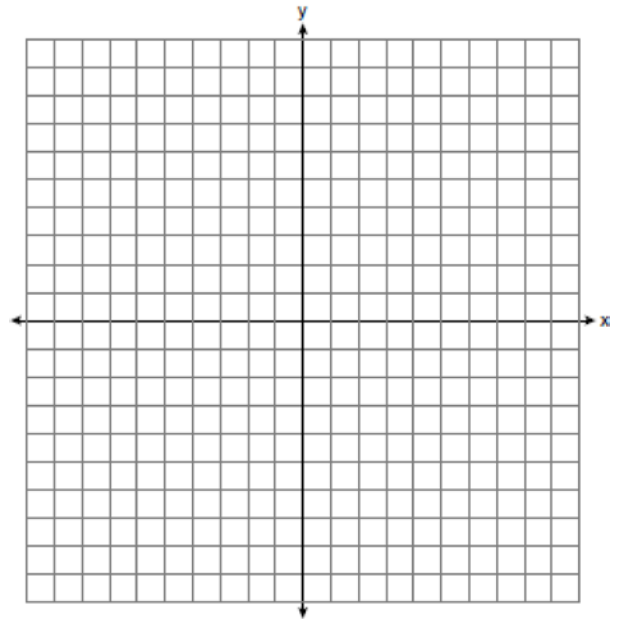

- 545 An oil company distributes oil in a metal can shaped like a cylinder that has an actual radius of 5.1 cm and a height of 15.1 cm. A worker incorrectly measured the radius as 5 cm and the height as 15 cm. Determine the relative error in calculating the surface area, to the nearest thousandth.

- 546 A stake is to be driven into the ground away from the base of a 50-foot pole, as shown in the diagram below. A wire from the stake on the ground to the top of the pole is to be installed at an angle of elevation of 52° .

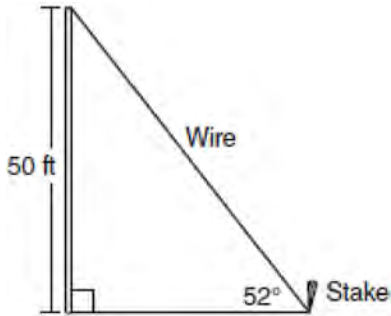

How far away from the base of the pole should the stake be driven in, to the *nearest foot*? What will be the length of the wire from the stake to the top of the pole, to the *nearest foot*?

- 547 The prices of seven race cars sold last week are listed in the table below.

Price per Race Car	Number of Race Cars
\$126,000	1
\$140,000	2
\$180,000	1
\$400,000	2
\$819,000	1

What is the mean value of these race cars, in dollars? What is the median value of these race cars, in dollars? State which of these measures of central tendency best represents the value of the seven race cars. Justify your answer.

- 548 The diagram below shows a cumulative frequency histogram of the students' test scores in Ms. Wedow's algebra class.

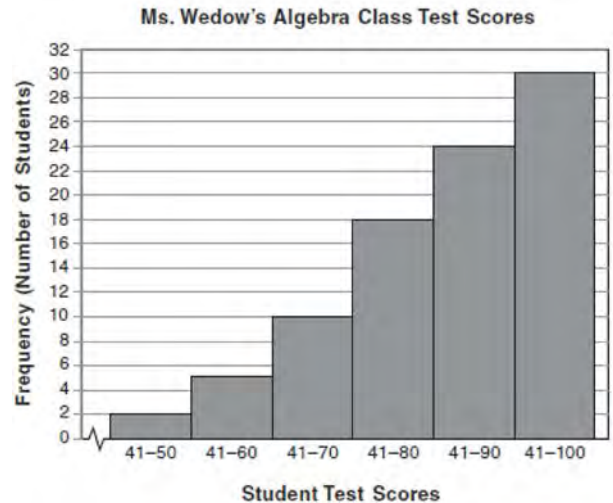

Determine the total number of students in the class. Determine how many students scored higher than 70. State which *ten-point interval* contains the median. State which *two ten-point intervals* contain the same frequency.

- 549 Solve algebraically for x :
 $3(x + 1) - 5x = 12 - (6x - 7)$

- 550 Vince buys a box of candy that consists of six chocolate pieces, four fruit-flavored pieces, and two mint pieces. He selects three pieces of candy at random, without replacement. Calculate the probability that the first piece selected will be fruit flavored and the other two will be mint. Calculate the probability that all three pieces selected will be the same type of candy.

- 551 On the set of axes below, solve the following system of equations graphically for all values of x and y .

$$y = x^2 - 6x + 1$$

$$y + 2x = 6$$

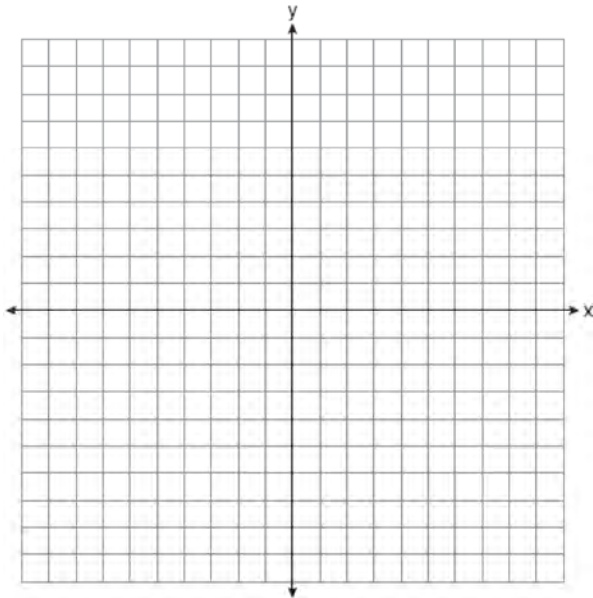

- 552 Find three consecutive positive even integers such that the product of the second and third integers is twenty more than ten times the first integer. [Only an algebraic solution can receive full credit.]

553 Solve algebraically for x : $\frac{3}{4} = \frac{-(x+11)}{4x} + \frac{1}{2x}$

- 554 The cost of 3 markers and 2 pencils is \$1.80. The cost of 4 markers and 6 pencils is \$2.90. What is the cost of *each* item? Include appropriate units in your answer.

- 555 The Fahrenheit temperature readings on 30 April mornings in Stormville, New York, are shown below.

41°, 58°, 61°, 54°, 49°, 46°, 52°, 58°, 67°, 43°,
 47°, 60°, 52°, 58°, 48°, 44°, 59°, 66°, 62°, 55°,
 44°, 49°, 62°, 61°, 59°, 54°, 57°, 58°, 63°, 60°

Using the data, complete the frequency table below.

Interval	Tally	Frequency
40–44		
45–49		
50–54		
55–59		
60–64		
65–69		

On the grid below, construct and label a frequency histogram based on the table.

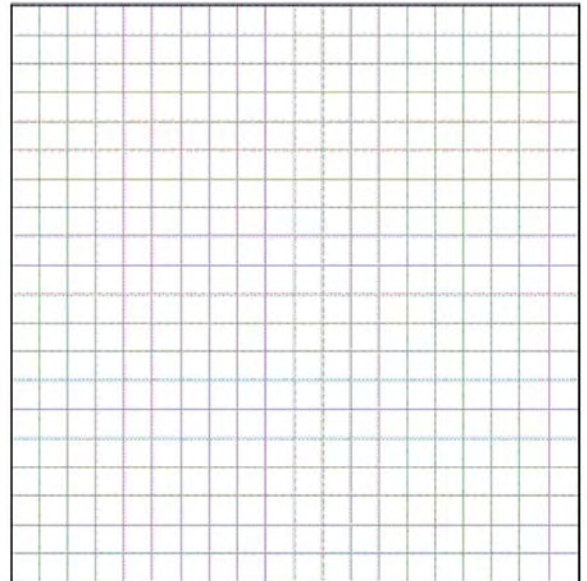

556 Express in simplest form:

$$\frac{x^2 + 9x + 14}{x^2 - 49} \div \frac{3x + 6}{x^2 + x - 56}$$

557 A sandwich consists of one type of bread, one type of meat, and one type of cheese. The possible choices are listed below.

- Bread: white, rye
- Meat: ham, turkey, beef
- Cheese: American, Swiss

Draw a tree diagram or list a sample space of all the possible different sandwiches consisting of one type of bread, one type of meat, and one type of cheese. Determine the number of sandwiches that will *not* include turkey. Determine the number of sandwiches that will include rye bread and Swiss cheese.

558 Each of the hats shown below has colored marbles placed inside. Hat A contains five green marbles and four red marbles. Hat B contains six blue marbles and five red marbles. Hat C contains five green marbles and five blue marbles.



If a student were to randomly pick one marble from each of these three hats, determine from which hat the student would most likely pick a green marble. Justify your answer. Determine the fewest number of marbles, if any, and the color of these marbles that could be added to *each* hat so that the probability of picking a green marble will be one-half in each of the three hats.

559 Graph the solution set for the inequality $4x - 3y > 9$ on the set of axes below. Determine if the point $(1, -3)$ is in the solution set. Justify your answer.

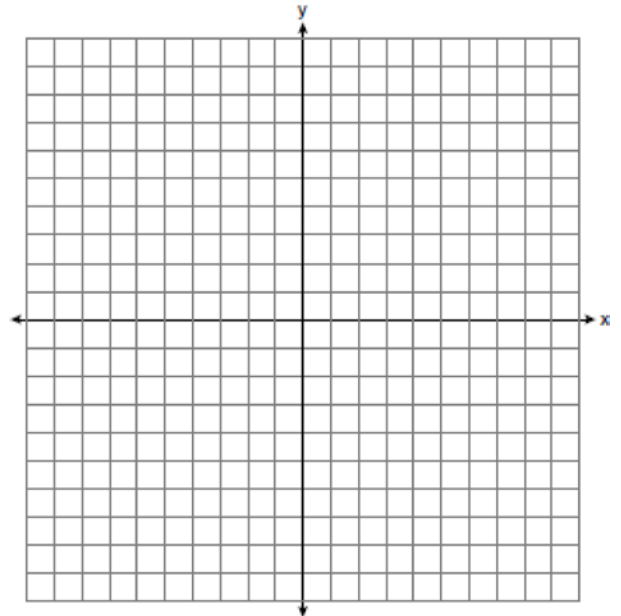

560 A restaurant sells kids' meals consisting of one main course, one side dish, and one drink, as shown in the table below.

Kids' Meal Choices

Main Course	Side Dish	Drink
hamburger	French fries	milk
chicken nuggets	applesauce	juice
turkey sandwich		soda

Draw a tree diagram or list the sample space showing all possible kids' meals. How many different kids' meals can a person order? Jose does not drink juice. Determine the number of different kids' meals that do *not* include juice. Jose's sister will eat *only* chicken nuggets for her main course. Determine the number of different kids' meals that include chicken nuggets.

Integrated Algebra 4 Point Regents Exam Questions
www.jmap.org

561 The sum of three consecutive odd integers is 18 less than five times the middle number. Find the three integers. [Only an algebraic solution can receive full credit.]

562 A contractor needs 54 square feet of brick to construct a rectangular walkway. The length of the walkway is 15 feet more than the width. Write an equation that could be used to determine the dimensions of the walkway. Solve this equation to find the length and width, in feet, of the walkway.

563 Solve the following systems of equations graphically, on the set of axes below, and state the coordinates of the point(s) in the solution set.

$$y = x^2 - 6x + 5$$

$$2x + y = 5$$

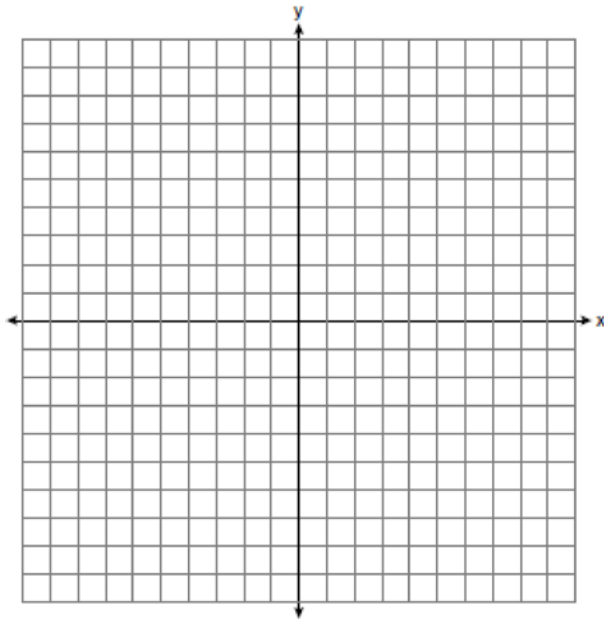

564 An outfit Jennifer wears to school consists of a top, a bottom, and shoes. Possible choices are listed below.

Tops: T-shirt, blouse, sweater

Bottoms: jeans, skirt, capris

Shoes: flip-flops, sneakers

List the sample space or draw a tree diagram to represent all possible outfits consisting of one type of top, one type of bottom, and one pair of shoes. Determine how many different outfits contain jeans and flip-flops. Determine how many different outfits do *not* include a sweater.

565 Solve the following system of equations algebraically:

$$3x + 2y = 4$$

$$4x + 3y = 7$$

[Only an algebraic solution can receive full credit.]

566 In right triangle ABC shown below, $AC = 29$ inches, $AB = 17$ inches, and $m\angle ABC = 90$. Find the number of degrees in the measure of angle BAC , to the *nearest degree*.

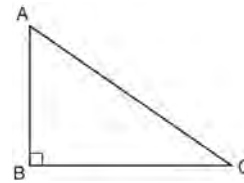

Find the length of \overline{BC} to the *nearest inch*.

567 Solve for x : $\frac{x+1}{x} = \frac{-7}{x-12}$

- 568 Graph the following systems of inequalities on the set of axes shown below and label the solution set S :

$$y > -x + 2$$

$$y \leq \frac{2}{3}x + 5$$

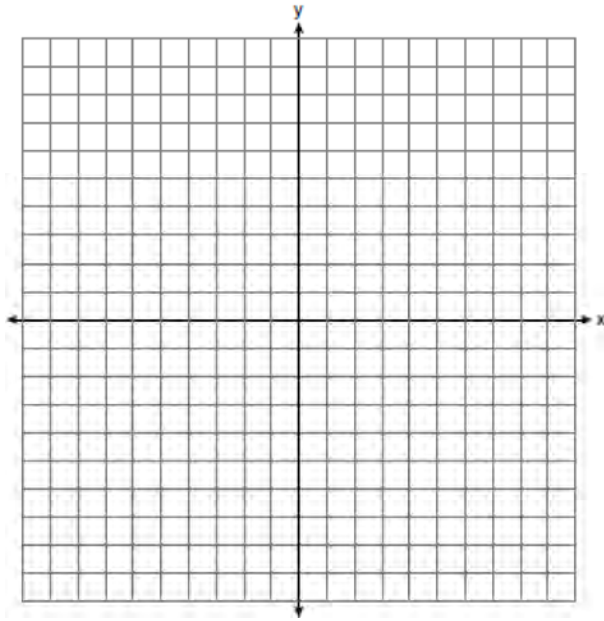

- 569 A company is running a contest and offering a first, second, and third prize. First prize is a choice of a car or \$15,000 cash. Second prize is a choice of a motorbike, a trip to New York City, or \$2,000 cash. Third prize is a choice of a television or \$500 cash. If each prize is equally likely to be selected, list the sample space or draw a tree diagram of *all* possible different outcomes of first, second, and third prizes. Determine the number of ways that *all* three prizes selected could be cash. Determine the number of ways that *none* of the three prizes selected could be cash.

570 Express in simplest form: $\frac{2x^2 - 8x - 42}{6x^2} \div \frac{x^2 - 9}{x^2 - 3x}$

- 571 A hot-air balloon is tied to the ground with two taut (straight) ropes, as shown in the diagram below. One rope is directly under the balloon and makes a right angle with the ground. The other rope forms an angle of 50° with the ground.

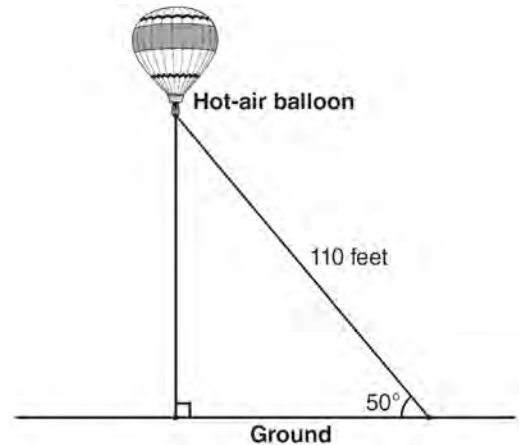

Determine the height, to the *nearest foot*, of the balloon directly above the ground. Determine the distance, to the *nearest foot*, on the ground between the two ropes.

- 572 A large company must choose between two types of passwords to log on to a computer. The first type is a four-letter password using any of the 26 letters of the alphabet, without repetition of letters. The second type is a six-digit password using the digits 0 through 9, with repetition of digits allowed. Determine the number of possible four-letter passwords. Determine the number of possible six-digit passwords. The company has 500,000 employees and needs a different password for each employee. State which type of password the company should choose. Explain your answer.

- 573 On the set of axes below, graph the following system of inequalities.

$$y + x \geq 3$$

$$5x - 2y > 10$$

State the coordinates of *one* point that satisfies $y + x \geq 3$, but does *not* satisfy $5x - 2y > 10$.

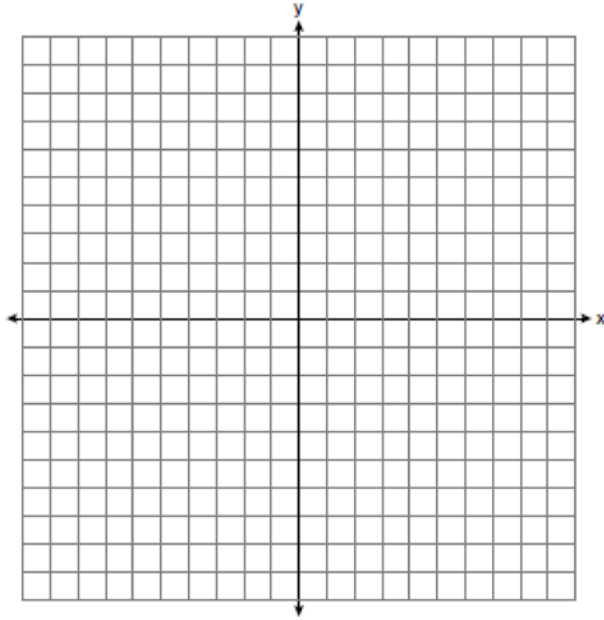

Number of Days Outside

Interval	Cumulative Frequency
0-1	
0-3	
0-5	
0-7	

On the grid below, create a cumulative frequency histogram based on the table you made.

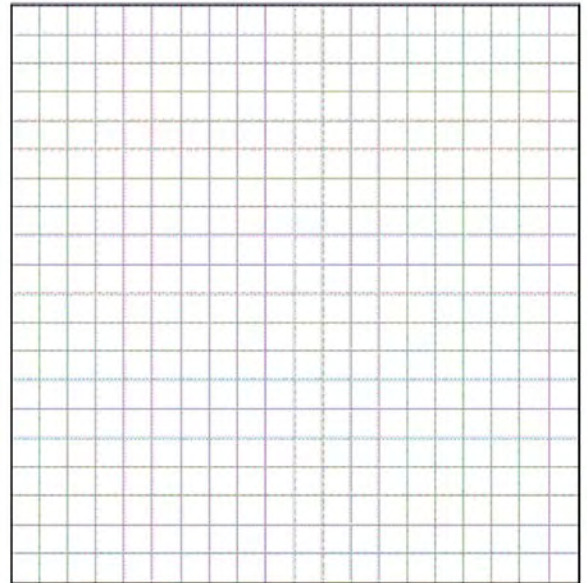

- 574 Twenty students were surveyed about the number of days they played outside in one week. The results of this survey are shown below.

{6,5,4,3,0,7,1,5,4,4,3,2,2,3,2,4,3,4,0,7}

Complete the frequency table below for these data.

Interval	Tally	Frequency
0-1		
2-3		
4-5		
6-7		

Complete the cumulative frequency table below using these data.

- 575 Shana wants to buy a new bicycle that has a retail price of \$259.99. She knows that it will be on sale next week for 30% off the retail price. If the tax rate is 7%, find the total amount, to the *nearest cent*, that she will save by waiting until next week.

Integrated Algebra 4 Point Regents Exam Questions

www.jmap.org

- 576 Solve the following system of inequalities graphically on the set of axes below.

$$3x + y < 7$$

$$y \geq \frac{2}{3}x - 4$$

State the coordinates of a point in the solution set.

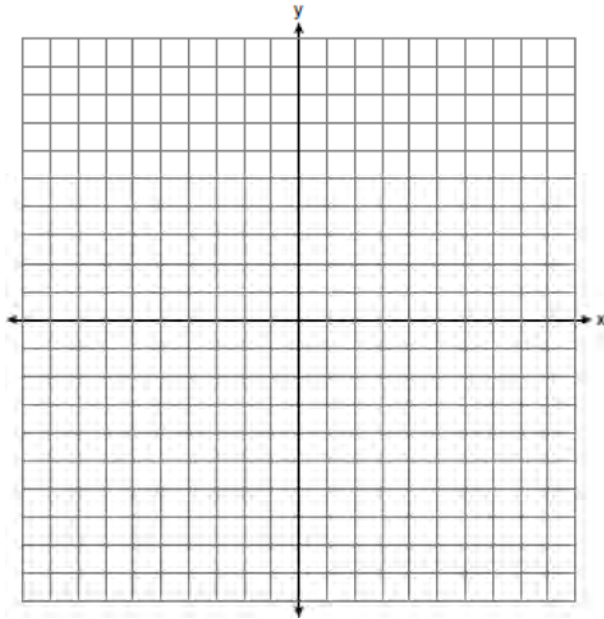

- 577 Mike buys his ice cream packed in a rectangular prism-shaped carton, while Carol buys hers in a cylindrical-shaped carton. The dimensions of the prism are 5 inches by 3.5 inches by 7 inches. The cylinder has a diameter of 5 inches and a height of 7 inches. Which container holds more ice cream? Justify your answer. Determine, to the *nearest tenth of a cubic inch*, how much more ice cream the larger container holds.

- 578 On the set of axes below, solve the following system of equations graphically and state the coordinates of *all* points in the solution set.

$$y = -x^2 + 6x - 3$$

$$x + y = 7$$

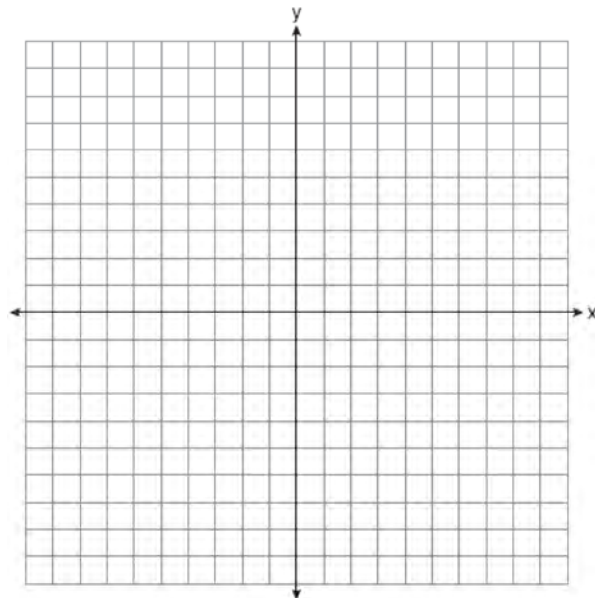

- 579 The Booster Club raised \$30,000 for a sports fund. No more money will be placed into the fund. Each year the fund will decrease by 5%. Determine the amount of money, to the *nearest cent*, that will be left in the sports fund after 4 years.

- 580 The test scores from Mrs. Gray's math class are shown below.
72, 73, 66, 71, 82, 85, 95, 85, 86, 89, 91, 92
Construct a box-and-whisker plot to display these data.

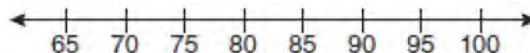

581 A password consists of three digits, 0 through 9, followed by three letters from an alphabet having 26 letters. If repetition of digits is allowed, but repetition of letters is not allowed, determine the number of different passwords that can be made. If repetition is not allowed for digits or letters, determine how many fewer different passwords can be made.

582 On the set of axes below, solve the following system of equations graphically for all values of x and y .

$$y = -x^2 - 4x + 12$$

$$y = -2x + 4$$

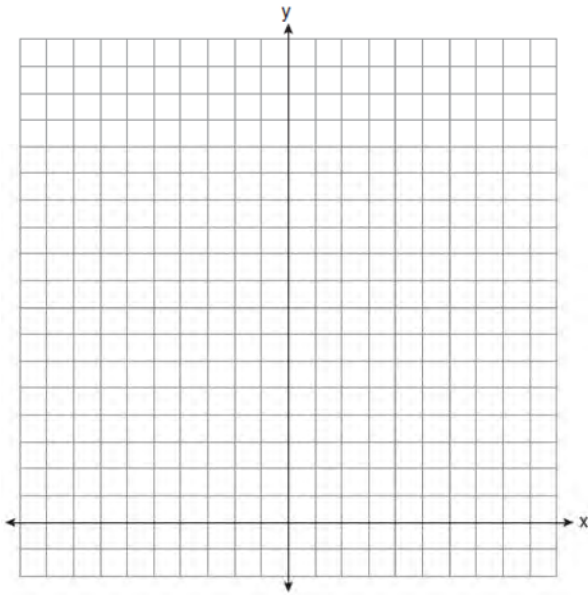

583 The values of 11 houses on Washington St. are shown in the table below.

Value per House	Number of Houses
\$100,000	1
\$175,000	5
\$200,000	4
\$700,000	1

Find the mean value of these houses in dollars.
 Find the median value of these houses in dollars.
 State which measure of central tendency, the mean or the median, *best* represents the values of these 11 houses. Justify your answer.

584 On the grid below, solve the system of equations graphically for x and y .

$$4x - 2y = 10$$

$$y = -2x - 1$$

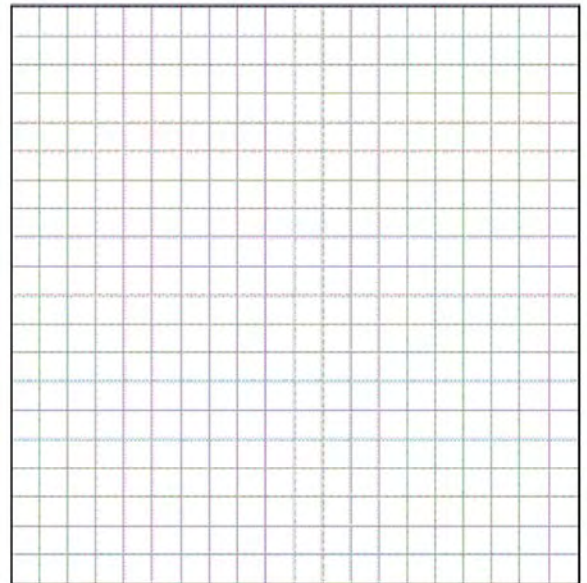

Integrated Algebra 4 Point Regents Exam Questions

www.jmap.org

- 585 On the set of axes below, solve the following system of equations graphically and state the coordinates of all points in the solution set.

$$y = x^2 + 4x - 5$$

$$y = x - 1$$

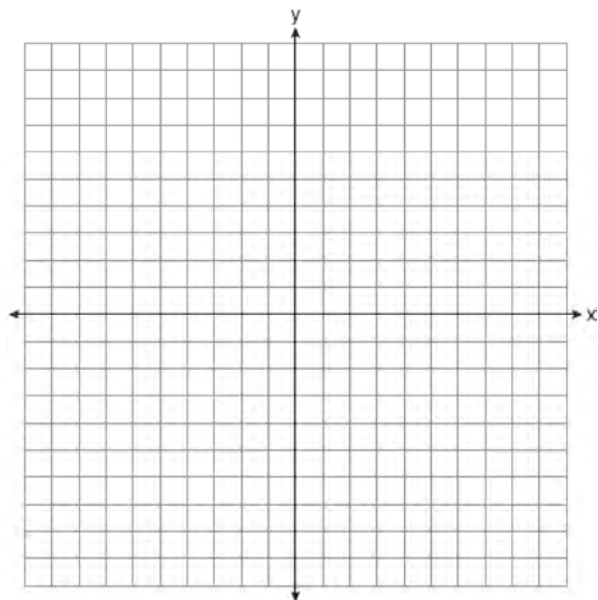

Integrated Algebra Multiple Choice Regents Exam Questions Answer Section

1 ANS: 3 REF: 011117ia STA: A.G.4 TOP: Graphing Absolute Value Functions

2 ANS: 3 REF: 081008ia STA: A.A.19
TOP: Factoring the Difference of Perfect Squares

3 ANS: 3

$$m = \frac{7-3}{-3-3} = \frac{4}{-6} = -\frac{2}{3} \quad y = mx + b$$

$$3 = -\frac{2}{3}(3) + b$$

$$3 = -2 + b$$

$$5 = b$$

REF: 011013ia STA: A.A.35 TOP: Writing Linear Equations

4 ANS: 1 REF: 061010ia STA: A.A.40 TOP: Systems of Linear Inequalities

5 ANS: 1 REF: 061114ia STA: A.A.43 TOP: Using Trigonometry to Find an Angle

6 ANS: 2 REF: 061023ia STA: A.A.23 TOP: Transforming Formulas

7 ANS: 2 REF: 061115ia STA: A.S.7 TOP: Scatter Plots

8 ANS: 2

$y - kx = 7$ may be rewritten as $y = kx + 7$

REF: 061015ia STA: A.A.38 TOP: Parallel and Perpendicular Lines

9 ANS: 2 REF: 081106ia STA: A.S.6 TOP: Box-and-Whisker Plots

10 ANS: 1 REF: 011004ia STA: A.A.31 TOP: Set Theory

11 ANS: 4

$$\frac{x}{x+4} \div \frac{2x}{x^2-16} = \frac{x}{x+4} \cdot \frac{x^2-16}{2x} = \frac{1}{x+4} \cdot \frac{(x+4)(x-4)}{2} = \frac{x-4}{2}$$

REF: 081130ia STA: A.A.18 TOP: Multiplication and Division of Rationals

KEY: division

12 ANS: 2

$$m = \frac{5-2}{3-(-2)} = \frac{3}{5}$$

REF: 061004ia STA: A.A.33 TOP: Slope

13 ANS: 1

$$\sin x = \frac{\text{opposite}}{\text{hypotenuse}} = \frac{28}{53}$$

REF: 011109ia STA: A.A.42 TOP: Trigonometric Ratios

14 ANS: 4 REF: 061130ia STA: A.A.13 TOP: Addition and Subtraction of Polynomials

KEY: subtraction

15 ANS: 1

$$-3(-4)^2(2) + 4(-4) = -96 - 16 = -112$$

REF: 081113ia STA: A.N.6 TOP: Evaluating Expressions

16 ANS: 1

$$\frac{12.8 + 17.2}{3 + 5} = 3.75$$

REF: 061117ia STA: A.M.1 TOP: Speed

17 ANS: 3

$$x = \frac{-b}{2a} = \frac{-10}{2(-1)} = 5.$$

REF: 081018ia STA: A.A.41 TOP: Identifying the Vertex of a Quadratic Given Equation

18 ANS: 4 REF: 011025ia STA: A.A.17 TOP: Addition and Subtraction of Rationals

19 ANS: 3

$$75 - 15 = 60$$

REF: 011113ia STA: A.S.6 TOP: Box-and-Whisker Plots

20 ANS: 2

$$m = \frac{-A}{B} = \frac{-3}{-7} = \frac{3}{7}$$

REF: 011122ia STA: A.A.37 TOP: Slope

21 ANS: 1

$$f + m = 53$$

$$f - m = 25$$

$$2m = 28$$

$$m = 14$$

REF: 061126ia STA: A.A.7 TOP: Writing Linear Systems

22 ANS: 4

$$SA = 2lw + 2hw + 2lh = 2(2)(3) + 2(4)(3) + 2(2)(4) = 52$$

REF: 011029ia STA: A.G.2 TOP: Surface Area

23 ANS: 3 REF: 011103ia STA: A.S.12 TOP: Scatter Plots

24 ANS: 2 REF: 011022ia STA: A.A.19

TOP: Factoring the Difference of Perfect Squares

25 ANS: 2 REF: 011005ia STA: A.A.5 TOP: Modeling Inequalities

26 ANS: 1

$$b = 2j + 4 \quad 2j + 4 = 31 - j$$

$$b + j = 31 \quad 3j = 27$$

$$b = 31 - j \quad j = 9$$

REF: 081119ia STA: A.A.7 TOP: Writing Linear Systems

27 ANS: 2

$$\tan A = \frac{\text{opposite}}{\text{adjacent}} = \frac{14}{48}$$

REF: 061009ia STA: A.A.42 TOP: Trigonometric Ratios

28 ANS: 3 REF: 011104ia STA: A.A.1 TOP: Expressions

29 ANS: 4 REF: 081011ia STA: A.A.5 TOP: Modeling Equations

30 ANS: 3

$$\frac{(12.3 \times 11.9) - (12.2 \times 11.8)}{12.3 \times 11.9} \approx 0.0165$$

REF: 061120ia STA: A.M.3 TOP: Error KEY: area

31 ANS: 1 REF: 081102ia STA: A.S.12 TOP: Scatter Plots

32 ANS: 1 REF: 061024ia STA: A.A.17 TOP: Addition and Subtraction of Rationals

33 ANS: 2 REF: 011012ia STA: A.G.9 TOP: Quadratic-Linear Systems

34 ANS: 2 REF: 081104ia STA: A.S.14 TOP: Analysis of Data

35 ANS: 1 REF: 011101ia STA: A.A.31 TOP: Set Theory

36 ANS: 2

$$\left| \frac{13.5 - 12.8}{13.5} \right| \approx 0.093$$

REF: 081123ia STA: A.M.3 TOP: Error KEY: area

37 ANS: 4

In (4), each element in the domain corresponds to a unique element in the range.

REF: 011018ia STA: A.G.3 TOP: Defining Functions

38 ANS: 2 REF: 011119ia STA: A.A.29 TOP: Set Theory

39 ANS: 1 REF: 061103ia STA: A.A.12 TOP: Division of Powers

40 ANS: 2

Candidate *B* received 45%. $45\% \times 1860 = 837$

REF: 081007ia STA: A.N.5 TOP: Percents

41 ANS: 3

$$\frac{2+x}{5x} - \frac{x-2}{5x} = \frac{2+x-x+2}{5x} = \frac{4}{5x}$$

REF: 081027ia STA: A.A.17 TOP: Addition and Subtraction of Rationals

42 ANS: 4

In (4), each element in the domain corresponds to a unique element in the range.

REF: 011105ia STA: A.G.3 TOP: Defining Functions

43 ANS: 2

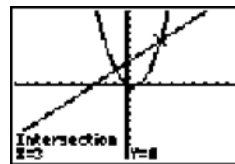

$x^2 - x = x + 3$. Since $y = x + 3$, the solutions are (3,6) and (-1,2).

$$x^2 - 2x - 3 = 0$$

$$(x - 3)(x + 1) = 0$$

$$x = 3 \text{ or } -1$$

REF: 061118ia STA: A.A.11 TOP: Quadratic-Linear Systems

44 ANS: 3

$$\frac{x}{3} + \frac{x+1}{2} = x$$

$$\frac{2x + 3(x+1)}{6} = x$$

$$5x + 3 = 6x$$

$$3 = x$$

REF: 061019ia STA: A.A.25 TOP: Solving Equations with Fractional Expressions

45 ANS: 1

The slope of $2x - 4y = 16$ is $\frac{-A}{B} = \frac{-2}{-4} = \frac{1}{2}$

REF: 011026ia STA: A.A.38 TOP: Parallel and Perpendicular Lines

46 ANS: 3

$$\frac{15}{15 + 13 + 12} = \frac{15}{40} = \frac{3}{8}$$

REF: 061006ia STA: A.S.21 TOP: Experimental Probability

47 ANS: 3

$$\sqrt{72} - 3\sqrt{2} = \sqrt{36}\sqrt{2} - 3\sqrt{2} = 6\sqrt{2} - 3\sqrt{2} = 3\sqrt{2}$$

REF: 061008ia STA: A.N.3 TOP: Operations with Radicals

KEY: subtraction

48 ANS: 2 REF: 011002ia STA: A.S.20 TOP: Theoretical Probability

49 ANS: 2

$$R = 0.5^{d-1}$$

REF: 011006ia STA: A.A.9 TOP: Exponential Functions

50 ANS: 3

$$\frac{12x^3 - 6x^2 + 2x}{2x} = \frac{2x(6x^2 - 3x + 1)}{2x} = 6x^2 - 3x + 1$$

REF: 011011ia STA: A.A.14 TOP: Division of Polynomials

51 ANS: 4 REF: 061028ia STA: A.G.6 TOP: Linear Inequalities

52 ANS: 2

$$2000(1 + 0.04)^3 \approx 2249$$

REF: 081124ia STA: A.A.9 TOP: Exponential Functions

53 ANS: 4

$$\frac{7}{12x} - \frac{y}{6x^2} = \frac{42x^2 - 12xy}{72x^3} = \frac{6x(7x - 2y)}{72x^3} = \frac{7x - 2y}{12x^2}$$

REF: 061129ia STA: A.A.17 TOP: Addition and Subtraction of Rationals

54 ANS: 4

$$-3x(x - 4) - 2x(x + 3) = -3x^2 + 12x - 2x^2 - 6x = -5x^2 + 6x$$

REF: 081114ia STA: A.A.13 TOP: Addition and Subtraction of Monomials

55 ANS: 4

$$s = \frac{d}{t} = \frac{150 \text{ m}}{1.5 \text{ min}} \cdot \frac{60 \text{ min}}{1 \text{ hr}} = 6,000 \frac{\text{m}}{\text{hr}}$$

REF: 061025ia STA: A.M.1 TOP: Speed

56 ANS: 3 REF: 061017ia STA: A.S.11 TOP: Quartiles and Percentiles

57 ANS: 3

$$3\sqrt{250} = 3\sqrt{25}\sqrt{10} = 15\sqrt{10}$$

REF: 061106ia STA: A.N.2 TOP: Simplifying Radicals

58 ANS: 2

$$A(-3,8) \text{ and } B(3,6). m = \frac{8-6}{-3-3} = \frac{2}{-6} = -\frac{1}{3}$$

REF: 081005ia STA: A.A.33 TOP: Slope

59 ANS: 4 REF: 061016ia STA: A.A.2 TOP: Expressions

60 ANS: 4 REF: 011111ia STA: A.G.8 TOP: Solving Quadratics by Graphing

61 ANS: 1 REF: 011126ia STA: A.A.13 TOP: Addition and Subtraction of Polynomials

KEY: subtraction

62 ANS: 4 REF: 011114ia STA: A.N.1 TOP: Properties of Reals

63 ANS: 4 REF: 061013ia STA: A.G.3 TOP: Defining Functions

64 ANS: 1

$$15000(1.2)^{\frac{6}{3}} = 21,600. 21,600 - 15,000 = 6,600$$

REF: 061030ia STA: A.A.9 TOP: Exponential Functions

65 ANS: 2
 $\sqrt{18.4^2 - 7^2} \approx 17$

REF: 011107ia STA: A.A.45 TOP: Pythagorean Theorem

66 ANS: 2 REF: 061121ia STA: A.A.3 TOP: Expressions

67 ANS: 1
 $3(2m - 1) \leq 4m + 7$

$$6m - 3 \leq 4m + 7$$

$$2m \leq 10$$

$$m \leq 5$$

REF: 081002ia STA: A.A.24 TOP: Solving Inequalities

68 ANS: 2 REF: 011015ia STA: A.G.10

TOP: Identifying the Vertex of a Quadratic Given Graph

69 ANS: 4
 $5 \times 2 \times 3 = 30$

REF: 061002ia STA: A.N.7 TOP: Multiplication Counting Principle

70 ANS: 3 REF: 081009ia STA: A.A.30 TOP: Set Theory

71 ANS: 3
 The age of a child does not cause the number of siblings he has, or vice versa.

REF: 011030ia STA: A.S.14 TOP: Analysis of Data

72 ANS: 2 REF: 061027ia STA: A.A.20 TOP: Factoring Polynomials

73 ANS: 3
 $\frac{(10w^3)^2}{5w} = \frac{100w^6}{5w} = 20w^5$

REF: 011124ia STA: A.A.12 TOP: Powers of Powers

74 ANS: 3 REF: 061003ia STA: A.A.13 TOP: Addition and Subtraction of Polynomials

KEY: addition

75 ANS: 4
 $\frac{150}{20} = \frac{x}{30}$

$$20x = 4500$$

$$x = 225$$

REF: 081101ia STA: A.N.5 TOP: Direct Variation

76 ANS: 2 REF: 011023ia STA: A.A.40 TOP: Systems of Linear Inequalities

77 ANS: 2 REF: 061122ia STA: A.S.14 TOP: Analysis of Data

78 ANS: 3

$$x^2 - 9 = 0$$

$$(x + 3)(x - 3) = 0$$

$$x = \pm 3$$

REF: 061014ia STA: A.A.15 TOP: Undefined Rationals

79 ANS: 4 REF: 011102ia STA: A.G.9 TOP: Quadratic-Linear Systems

80 ANS: 4 REF: 061022ia STA: A.S.3 TOP: Analysis of Data

81 ANS: 4

The other situations are quantitative.

REF: 081122ia STA: A.S.1 TOP: Analysis of Data

82 ANS: 3

$$V = \pi r^2 h = \pi \cdot 5^2 \cdot 2.3 \approx 180.6$$

REF: 081105ia STA: A.G.2 TOP: Volume

83 ANS: 1 REF: 081015ia STA: A.G.5 TOP: Graphing Quadratic Functions

84 ANS: 1

$$7 + 8 + 7 + \frac{12\pi}{2} = 22 + 6\pi$$

REF: 081128ia STA: A.G.1 TOP: Compositions of Polygons and Circles

KEY: perimeter

85 ANS: 2

Debbie failed to distribute the 3 properly.

REF: 011009ia STA: A.A.22 TOP: Solving Equations

86 ANS: 2

$$A = lw + lw + \frac{\pi r^2}{4} = 5 \cdot 3 + 5 \cdot 3 + \frac{\pi \cdot 3^2}{4} \approx 37$$

REF: 011123ia STA: A.G.1 TOP: Compositions of Polygons and Circles

KEY: area

87 ANS: 4

$${}_5P_5 = 5 \times 4 \times 3 \times 2 \times 1 = 120$$

REF: 061109ia STA: A.N.8 TOP: Permutations

88 ANS: 3 REF: 081017a STA: A.S.14 TOP: Analysis of Data

89 ANS: 2

$$\tan ABC = \frac{\text{opposite}}{\text{adjacent}} = \frac{5}{12}$$

REF: 081112ia STA: A.A.42 TOP: Trigonometric Ratios

90 ANS: 2

$$m = \frac{5-3}{8-1} = \frac{2}{7} \quad y - y_1 = m(x - x_1)$$

$$y - 5 = \frac{2}{7}(x - 8)$$

REF: 081029ia STA: A.A.35 TOP: Writing Linear Equations

91 ANS: 2

$$J - M = 3$$

$$8J + 8M = 120$$

$$8J - 8M = 24$$

$$16J = 144$$

$$J = 9$$

REF: 011115ia STA: A.A.7 TOP: Writing Linear Systems

92 ANS: 3

$$\frac{3+2+4+3}{20} = \frac{12}{20}$$

REF: 011129ia STA: A.S.21 TOP: Experimental Probability

93 ANS: 2

$$\left| \frac{55.42 - 50.27}{55.42} \right| \approx 0.093$$

REF: 081023ia STA: A.M.3 TOP: Error KEY: area

94 ANS: 2 REF: 011110ia STA: A.N.6 TOP: Evaluating Expressions

95 ANS: 2

$$\sin 57 = \frac{x}{8}$$

$$x \approx 6.7$$

REF: 061108ia STA: A.A.44 TOP: Using Trigonometry to Find a Side

96 ANS: 3

$$m = \frac{6-4}{3-(-2)} = \frac{2}{5}$$

REF: 061110ia STA: A.A.33 TOP: Slope

97 ANS: 2 REF: 081127ia STA: A.A.40 TOP: Systems of Linear Inequalities

98 ANS: 3

$$\cos A = \frac{\text{adjacent}}{\text{hypotenuse}} = \frac{15}{17}$$

REF: 011008ia STA: A.A.42 TOP: Trigonometric Ratios

99 ANS: 3 REF: 081001ia STA: A.S.7 TOP: Scatter Plots

100 ANS: 2

$$x^2 - 5x + 6 = 0$$

$$(x - 3)(x - 2) = 0$$

$$x = 3 \quad x = 2$$

REF: 081120ia

STA: A.A.28

TOP: Roots of Quadratics

101 ANS: 2

REF: 061127ia

STA: A.N.4

TOP: Operations with Scientific Notation

102 ANS: 4

$$-6x - 17 \geq 8x + 25$$

$$-42 \geq 14x$$

$$-3 \geq x$$

REF: 081121ia

STA: A.A.24

TOP: Solving Inequalities

103 ANS: 4

REF: 011020ia

STA: A.A.12

TOP: Multiplication of Powers

104 ANS: 2

REF: 061128ia

STA: A.A.29

TOP: Set Theory

105 ANS: 2

REF: 081003ia

STA: A.A.31

TOP: Set Theory

106 ANS: 1

REF: 011001ia

STA: A.S.6

TOP: Box-and-Whisker Plots

107 ANS: 3

$$10^2 + 10^2 = c^2$$

$$c^2 = 200$$

$$c \approx 14.1$$

REF: 061102ia

STA: A.A.45

TOP: Pythagorean Theorem

108 ANS: 3

REF: 011017ia

STA: A.G.5

TOP: Graphing Absolute Value Functions

109 ANS: 2

REF: 061105ia

STA: A.A.20

TOP: Factoring Polynomials

110 ANS: 3

$$2(1) + 3 = 5$$

REF: 061007ia

STA: A.A.39

TOP: Linear Equations

111 ANS: 1

REF: 081030ia

STA: A.A.3

TOP: Expressions

112 ANS: 1

$$1P + 2C = 5$$

$$1P + 4C = 6$$

$$2C = 1$$

$$C = 0.5$$

REF: 011003ia

STA: A.A.7

TOP: Writing Linear Systems

113 ANS: 1
 $2(x - 4) = 4(2x + 1)$
 $2x - 8 = 8x + 4$
 $-12 = 6x$
 $-2 = x$

REF: 011106ia STA: A.A.22 TOP: Solving Equations

114 ANS: 1 REF: 081115ia STA: A.A.32 TOP: Slope

115 ANS: 3
 mean = $81\frac{7}{11}$, median = 81 and mode = 76

REF: 011118ia STA: A.S.4 TOP: Central Tendency

116 ANS: 4 REF: 081107ia STA: A.A.5 TOP: Modeling Inequalities

117 ANS: 3 REF: 061011ia STA: A.S.2 TOP: Analysis of Data

118 ANS: 4 REF: 061111ia STA: A.G.4 TOP: Families of Functions

119 ANS: 1 REF: 061021ia STA: A.A.29 TOP: Set Theory

120 ANS: 2
 $\cos 38 = \frac{10}{x}$
 $x = \frac{10}{\cos 38} \approx 12.69$

REF: 081126ia STA: A.A.44 TOP: Using Trigonometry to Find a Side

121 ANS: 4
 $2x - 3y = 9$
 $2(0) - 3(-3) = 9$
 $0 + 9 = 9$

REF: 081016ia STA: A.A.39 TOP: Identifying Points on a Line

122 ANS: 2
 In (2), each element in the domain corresponds to a unique element in the range.

REF: 061116ia STA: A.G.3 TOP: Defining Functions

123 ANS: 3
 $P(\text{odd}) = \frac{3}{6}$, $P(\text{prime}) = \frac{3}{6}$, $P(\text{perfect square}) = \frac{2}{6}$, $P(\text{even}) = \frac{3}{6}$

REF: 061104ia STA: A.S.22 TOP: Geometric Probability

124 ANS: 2
 $2(x - 3y = -3)$
 $2x + y = 8$
 $2x - 6y = -6$
 $7y = 14$
 $y = 2$

REF: 081021ia STA: A.A.10 TOP: Solving Linear Systems

125 ANS: 2
 $x^2 - 2x - 15 = 0$
 $(x - 5)(x + 3) = 0$
 $x = 5 \quad x = -3$

REF: 011128ia STA: A.A.28 TOP: Roots of Quadratics

126 ANS: 4 REF: 061018ia STA: A.A.12 TOP: Division of Powers

127 ANS: 1 REF: 081110ia STA: A.A.1 TOP: Expressions

128 ANS: 4 REF: 081025ia STA: A.G.4 TOP: Families of Functions

129 ANS: 1
 Asking school district employees about a school board candidate produces the most bias.

REF: 061107ia STA: A.S.3 TOP: Analysis of Data

130 ANS: 1
 $x = \frac{-b}{2a} = \frac{-6}{2(-1)} = 3.$

REF: 011127ia STA: A.A.41 TOP: Identifying the Vertex of a Quadratic Given Equation

131 ANS: 4
 $6\sqrt{50} + 6\sqrt{2} = 6\sqrt{25} \sqrt{2} + 6\sqrt{2} = 30\sqrt{2} + 6\sqrt{2} = 36\sqrt{2}$

REF: 011024ia STA: A.N.3 TOP: Operations with Radicals
 KEY: addition

132 ANS: 1
 $y = mx + b$
 $5 = (-2)(1) + b$
 $b = 7$

REF: 081108ia STA: A.A.34 TOP: Writing Linear Equations

133 ANS: 2
 $\frac{3}{2x} + \frac{7}{4x} = \frac{12x + 14x}{8x^2} = \frac{26x}{8x^2} = \frac{13}{4x}$

REF: 011120ia STA: A.A.17 TOP: Addition and Subtraction of Rationals

134 ANS: 2

$$20000(.88)^3 = 13629.44$$

REF: 061124ia STA: A.A.9 TOP: Exponential Functions

135 ANS: 3 REF: 061101ia STA: A.A.19

TOP: Factoring the Difference of Perfect Squares

136 ANS: 4

$$5(x+4) = 5x+20$$

REF: 081013ia STA: A.A.1 TOP: Expressions

137 ANS: 3

Frequency is not a variable.

REF: 011014ia STA: A.S.2 TOP: Analysis of Data

138 ANS: 4 REF: 061112ia STA: A.A.36 TOP: Parallel and Perpendicular Lines

139 ANS: 1

$$\frac{x^2 - x - 6}{x^2 - 5x + 6} = \frac{(x-3)(x+2)}{(x-3)(x+2)} = \frac{x+2}{x-2}$$

REF: 011130ia STA: A.A.16 TOP: Rational Expressions

KEY: $a > 0$

140 ANS: 1 REF: 061005ia STA: A.G.10

TOP: Identifying the Vertex of a Quadratic Given Graph

141 ANS: 1

$$-|a-b| = -|7-(-3)| = -|-10| = -10$$

REF: 011010ia STA: A.N.6 TOP: Evaluating Expressions

142 ANS: 4

$$x^2 - 4x - 12 = 0$$

$$(x-6)(x+2) = 0$$

$$x = 6 \quad x = -2$$

REF: 061125ia STA: A.A.15 TOP: Undefined Rationals

143 ANS: 2

$$\sqrt{5^2 + 7^2} \approx 8.6$$

REF: 081004ia STA: A.A.45 TOP: Pythagorean Theorem

144 ANS: 1

$$2y - 2x = 10 \quad \text{axis of symmetry: } x = \frac{-b}{2a} = \frac{-2}{2(1)} = -1$$

$$2y = 2x + 10$$

$$y = x + 5$$

REF: 081010ia STA: A.G.9 TOP: Quadratic-Linear Systems

145 ANS: 3

$$P(S) \cdot P(M) = P(S \text{ and } M)$$

$$\frac{3}{5} \cdot P(M) = \frac{3}{10}$$

$$P(M) = \frac{1}{2}$$

REF: 081024ia STA: A.S.23

TOP: Theoretical Probability

KEY: independent events

146 ANS: 1

$$x^2 - 36 = 5x$$

$$x^2 - 5x - 36 = 0$$

$$(x - 9)(x + 4) = 0$$

$$x = 9$$

REF: 061020ia STA: A.A.8

TOP: Writing Quadratics

147 ANS: 4

$${}_8P_3 = 336$$

REF: 061026ia STA: A.N.8

TOP: Permutations

148 ANS: 2

$$l(l - 3) = 40$$

$$l^2 - 3l - 40 = 0$$

$$(l - 8)(l + 5) = 0$$

$$l = 8$$

REF: 081116ia STA: A.A.8

TOP: Geometric Applications of Quadratics

149 ANS: 4

REF: 061001ia

STA: A.A.30

TOP: Set Theory

150 ANS: 4

REF: 081022ia

STA: A.A.29

TOP: Set Theory

151 ANS: 2

REF: 061113ia

STA: A.G.5

TOP: Graphing Quadratic Functions

152 ANS: 3

REF: 061119ia

STA: A.A.2

TOP: Expressions

153 ANS: 4

$$\frac{2+3+0+1+3+2+4+0+2+3}{10} = \frac{20}{10} = 2 \quad \frac{x}{10} = 2 + 0.5$$

$$x = 25$$

REF: 081020ia STA: A.S.16

TOP: Average Known with Missing Data

154 ANS: 1
 $4y - 2x = 0$
 $4(-1) - 2(-2) = 0$
 $-4 + 4 = 0$

REF: 011021ia STA: A.A.39 TOP: Identifying Points on a Line

155 ANS: 2 REF: 011027ia STA: A.A.3 TOP: Expressions

156 ANS: 4 REF: 061123ia STA: A.A.31 TOP: Set Theory

157 ANS: 2 REF: 011019ia STA: A.S.12 TOP: Scatter Plots

158 ANS: 2

$$A = lw + \frac{\pi r^2}{2} = 6 \cdot 5 + \frac{\pi \cdot 3^2}{2} \approx 44.1$$

REF: 061029ia STA: A.G.1 TOP: Compositions of Polygons and Circles

KEY: area

159 ANS: 3
 ${}_6P_4 = 360$

REF: 081028ia STA: A.N.8 TOP: Permutations

160 ANS: 3
 $2x - 5y = 11$ $2x - 5(-1) = 11$
 $-2x + 3y = -9$ $2x = 6$
 $-2y = 2$ $x = 3$
 $y = -1$

REF: 081109ia STA: A.A.10 TOP: Solving Linear Systems

161 ANS: 3 REF: 081118ia STA: A.G.4 TOP: Families of Functions

162 ANS: 3
 $c + 3d = 8$ $c = 4d - 6$

$$4d - 6 + 3d = 8 \quad c = 4(2) - 6$$

$$7d = 14 \quad c = 2$$

$$d = 2$$

REF: 061012ia STA: A.A.10 TOP: Solving Linear Systems

163 ANS: 3
 $P(O) = \frac{5}{10}, P(P) = \frac{4}{10}, P(\leq 5) = \frac{6}{10}, P(3) = \frac{4}{10}$

REF: 081125ia STA: A.S.22 TOP: Theoretical Probability

164 ANS: 3 REF: 081117ia STA: A.A.29 TOP: Set Theory

165 ANS: 2

shaded = whole – unshaded

= rectangle-triangle

$$= lw - \frac{1}{2}bh$$

$$= 15 \times 6 - \frac{1}{2} \times 15 \times 4.6$$

$$= 90 - 34.5$$

$$= 55.5$$

REF: 081019ia

STA: A.G.1

TOP: Compositions of Polygons and Circles

KEY: area

166 ANS: 4

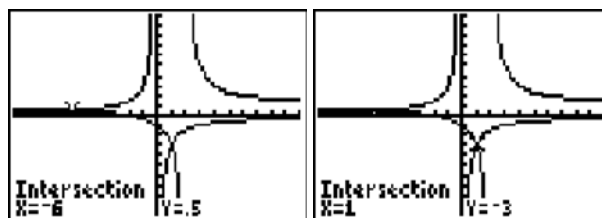

$$\frac{x+2}{x-2} = \frac{-3}{x}$$

$$x(x+2) = -3(x-2)$$

$$x^2 + 2x = -3x + 6$$

$$x^2 + 5x - 6 = 0$$

$$(x+6)(x-1) = 0$$

$$x = -6 \text{ or } 1$$

REF: 011028ia

STA: A.A.26

TOP: Solving Rationals

167 ANS: 4

$$\frac{ey}{n} + k = t$$

$$\frac{ey}{n} = t - k$$

$$y = \frac{n(t-k)}{e}$$

REF: 011125ia

STA: A.A.23

TOP: Transforming Formulas

168 ANS: 2

$$\frac{2x-3}{x-4} = \frac{2}{3}$$

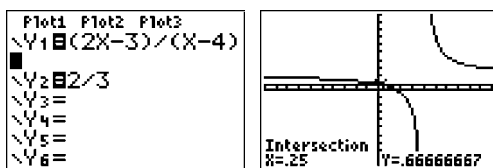

$$3(2x-3) = 2(x-4)$$

$$6x-9 = 2x-8$$

$$4x = 1$$

$$x = \frac{1}{4}$$

REF: 081012ia STA: A.A.26 TOP: Solving Rationals

169 ANS: 1

$$\frac{2x}{3} + \frac{1}{2} = \frac{5}{6}$$

$$\frac{2x}{3} = \frac{1}{3}$$

$$6x = 3$$

$$x = \frac{1}{2}$$

REF: 011112ia STA: A.A.25 TOP: Solving Equations with Fractional Expressions

170 ANS: 4

The other sets of data are qualitative.

REF: 011116ia STA: A.S.1 TOP: Analysis of Data

171 ANS: 3

$$3\sqrt{2} + \sqrt{8} = 3\sqrt{2} + \sqrt{4}\sqrt{2} = 3\sqrt{2} + 2\sqrt{2} = 5\sqrt{2}$$

REF: 011121ia STA: A.N.3 TOP: Operations with Radicals

KEY: addition

172 ANS: 2 REF: 081014ia STA: A.A.36 TOP: Parallel and Perpendicular Lines

173 ANS: 2

$$a^3 - 4a = a(a^2 - 4) = a(a-2)(a+2)$$

REF: 011108ia STA: A.A.19 TOP: Factoring the Difference of Perfect Squares

174 ANS: 4 REF: 011016ia STA: A.A.23 TOP: Transforming Formulas

175 ANS: 2

$$36x^2 - 100y^6 = 4(9x^2 - 25y^6) = 4(3x + 5y^3)(3x - 5y^3)$$

REF: 081129ia STA: A.A.19 TOP: Factoring the Difference of Perfect Squares

176 ANS: 4

$$A(-3,4) \text{ and } B(5,8). \quad m = \frac{4-8}{-3-5} = \frac{-4}{-8} = \frac{1}{2}$$

REF: 011007ia STA: A.A.33 TOP: Slope

177 ANS: 2

$$\tan B = \frac{\text{opposite}}{\text{adjacent}} = \frac{8}{15} = 0.5\bar{3}$$

REF: 081026ia STA: A.A.42 TOP: Trigonometric Ratios

Integrated Algebra Multiple Choice Regents Exam Questions Answer Section

178 ANS: 2

$$\left| \frac{(2.6 \times 6.9) - (2.5 \times 6.8)}{(2.6 \times 6.9)} \right| \approx 0.052$$

REF: 011209ia STA: A.M.3 TOP: Error KEY: area

179 ANS: 2 REF: 011201ia STA: A.A.19

TOP: Factoring the Difference of Perfect Squares

180 ANS: 4 REF: 011225ia STA: A.A.31 TOP: Set Theory

181 ANS: 3

$$0.06y + 200 = 0.03y + 350$$

$$0.03y = 150$$

$$y = 5,000$$

REF: 081203ia STA: A.A.25 TOP: Solving Equations with Decimals

182 ANS: 1

$$s = \frac{2x + t}{r}$$

$$rs = 2x + t$$

$$rs - t = 2x$$

$$\frac{rs - t}{2} = x$$

REF: 011228ia STA: A.A.23 TOP: Transforming Formulas

183 ANS: 3 REF: 011224ia STA: A.N.1 TOP: Properties of Reals

184 ANS: 3 REF: 081208ia STA: A.S.17 TOP: Scatter Plots

185 ANS: 3

The other situations are qualitative.

REF: 081213ia STA: A.S.1 TOP: Analysis of Data

186 ANS: 2

$$13^2 + 13^2 = x^2$$

$$338 = x^2$$

$$\sqrt{338} = x$$

$$18 \approx x$$

REF: 061223ia STA: A.A.45 TOP: Pythagorean Theorem

187 ANS: 3

$$y = mx + b \quad y = \frac{3}{4}x - \frac{1}{2}$$

$$1 = \left(\frac{3}{4}\right)(2) + b \quad 4y = 3x - 2$$

$$1 = \frac{3}{2} + b$$

$$b = -\frac{1}{2}$$

REF: 081219ia STA: A.A.34 TOP: Writing Linear Equations

188 ANS: 1

$$\frac{\text{distance}}{\text{time}} = \frac{350.7}{4.2} = 83.5$$

REF: 061201ia STA: A.M.1 TOP: Speed

189 ANS: 3 REF: 061208ia STA: A.A.31 TOP: Set Theory

190 ANS: 3 REF: 061206ia STA: A.S.2 TOP: Analysis of Data

191 ANS: 2 REF: 081205ia STA: A.A.13 TOP: Addition and Subtraction of Polynomials

KEY: addition

192 ANS: 3 REF: 081207ia STA: A.A.19

TOP: Factoring the Difference of Perfect Squares

193 ANS: 1

$$3x^2 - 27x = 0$$

$$3x(x - 9) = 0$$

$$x = 0, 9$$

REF: 011223ia STA: A.A.28 TOP: Roots of Quadratics

194 ANS: 3

$$\frac{120}{60} = \frac{m}{150}$$

$$m = 300$$

REF: 081202ia STA: A.M.1 TOP: Using Rate

195 ANS: 4

$$8900 \text{ ft} \times \frac{1 \text{ mi}}{5280 \text{ ft}} \approx 1.7 \text{ mi}$$

REF: 081210ia STA: A.M.2 TOP: Conversions KEY: dimensional analysis

196 ANS: 2 REF: 081212ia STA: A.A.5 TOP: Modeling Inequalities

197 ANS: 4 REF: 081229ia STA: A.S.23 TOP: Theoretical Probability

KEY: independent events

198 ANS: 4 REF: 081214ia STA: A.G.10

TOP: Identifying the Vertex of a Quadratic Given Graph

- 199 ANS: 2 REF: 011227ia STA: A.A.3 TOP: Expressions
 200 ANS: 1 REF: 061204ia STA: A.A.1 TOP: Expressions
 201 ANS: 1 REF: 011213ia STA: A.A.13 TOP: Addition and Subtraction of Polynomials
 KEY: addition
 202 ANS: 2

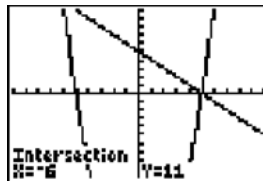

$$y = -x + 5. \quad -x + 5 = x^2 - 25 \quad . \quad y = -(-6) + 5 = 11.$$

$$0 = x^2 + x - 30 \quad y = -5 + 5 = 0$$

$$0 = (x + 6)(x - 5)$$

$$x = -6, 5$$

- REF: 061213ia STA: A.A.11 TOP: Quadratic-Linear Systems
 203 ANS: 4
 $SA = 2lw + 2hw + 2lh = 2(3)(2.2) + 2(7.5)(2.2) + 2(3)(7.5) = 91.2$

- REF: 081216ia STA: A.G.2 TOP: Surface Area
 204 ANS: 2 REF: 081215ia STA: A.A.1 TOP: Expressions
 205 ANS: 3 REF: 061217ia STA: A.A.29 TOP: Set Theory
 206 ANS: 1 REF: 061209ia STA: A.G.3 TOP: Defining Functions
 207 ANS: 3 REF: 081211ia STA: A.A.9 TOP: Exponential Functions
 208 ANS: 4

$$m = \frac{-A}{B} = \frac{-(-3)}{2} = \frac{3}{2}$$

- REF: 061212ia STA: A.A.37 TOP: Slope
 209 ANS: 2

$$\frac{x^2 - 3x - 10}{x^2 - 25} = \frac{(x - 5)(x + 2)}{(x + 5)(x - 5)} = \frac{x + 2}{x + 5}$$

- REF: 061216ia STA: A.A.16 TOP: Rational Expressions
 KEY: $a > 0$
 210 ANS: 1
 $x^2 + 5x - 6 = 0$
 $(x + 6)(x - 1) = 0$
 $x = -6, 1$

- REF: 011214ia STA: A.A.15 TOP: Undefined Rationals

211 ANS: 3

$$x^2 - 4 = 0$$

$$(x + 2)(x - 2) = 0$$

$$x = \pm 2$$

REF: 081225ia STA: A.A.15 TOP: Undefined Rationals

212 ANS: 4

$$3x^3 - 33x^2 + 90x = 3x(x^2 - 11x + 30) = 3x(x - 5)(x - 6)$$

REF: 061227ia STA: A.A.20 TOP: Factoring Polynomials

213 ANS: 4

$$m = \frac{-3 - 1}{2 - 5} = \frac{-4}{-3} = \frac{4}{3}$$

REF: 011215ia STA: A.A.33 TOP: Slope

214 ANS: 1 REF: 081209ia STA: A.N.1 TOP: Properties of Reals

215 ANS: 3

$$\tan PLM = \frac{\text{opposite}}{\text{adjacent}} = \frac{4}{3}$$

REF: 011226ia STA: A.A.42 TOP: Trigonometric Ratios

216 ANS: 2 REF: 011212ia STA: A.S.23 TOP: Theoretical Probability

KEY: independent events

217 ANS: 3

$$5x < 55$$

$$x < 11$$

REF: 061211ia STA: A.A.6 TOP: Modeling Inequalities

218 ANS: 2 REF: 061205ia STA: A.S.12 TOP: Scatter Plots

219 ANS: 1

$$x = \frac{-b}{2a} = \frac{-(-3)}{2(2)} = \frac{3}{4}$$

REF: 011219ia STA: A.A.41 TOP: Identifying the Vertex of a Quadratic Given Equation

220 ANS: 3 REF: 061225ia STA: A.A.5 TOP: Modeling Equations

221 ANS: 2

$$\frac{2y}{y+5} + \frac{10}{y+5} = \frac{2y+10}{y+5} = \frac{2(y+5)}{y+5} = 2$$

REF: 011230ia STA: A.A.17 TOP: Addition and Subtraction of Rationals

222 ANS: 2

People at a gym or football game and members of a soccer team are more biased towards sports.

REF: 061202ia STA: A.S.3 TOP: Analysis of Data

223 ANS: 4

$$\frac{95000}{125000} = .76$$

REF: 061207ia STA: A.S.11 TOP: Quartiles and Percentiles

224 ANS: 1

If the area of the square is 36, a side is 6, the diameter of the circle is 6, and its radius is 3. $A = \pi r^2 = 3^2 \pi = 9\pi$

REF: 011217ia STA: A.G.1 TOP: Compositions of Polygons and Circles

KEY: area

225 ANS: 3

$$\frac{2}{x+1} = \frac{x+1}{2}$$

$$x^2 + 2x + 1 = 4$$

$$x^2 + 2x - 3 = 0$$

$$(x+3)(x-1) = 3$$

$$x = -3, 1$$

REF: 081226ia STA: A.A.26 TOP: Solving Rationals

226 ANS: 1

$$k = am + 3mx$$

$$k = m(a + 3x)$$

$$\frac{k}{a + 3x} = m$$

REF: 061215ia STA: A.A.23 TOP: Transforming Formulas

227 ANS: 3 REF: 011204ia STA: A.G.3 TOP: Defining Functions

228 ANS: 1

$$\frac{3}{4} \times 5 = \frac{15}{4} \text{ teaspoons} \times \frac{1 \text{ tablespoon}}{3 \text{ teaspoons}} = \frac{5}{4} = 1 \frac{1}{4} \text{ tablespoon}$$

REF: 061228ia STA: A.M.2 TOP: Conversions KEY: dimensional analysis

229 ANS: 3

$$(3x+2)(x-7) = 3x^2 - 21x + 2x - 14 = 3x^2 - 19x - 14$$

REF: 061210ia STA: A.A.13 TOP: Multiplication of Polynomials

230 ANS: 4 REF: 061203ia STA: A.A.14 TOP: Division of Polynomials

231 ANS: 4

$$\frac{(4x^3)^2}{2x} = \frac{16x^6}{2x} = 8x^5$$

REF: 011216ia STA: A.A.12 TOP: Powers of Powers

232 ANS: 3

$$\frac{3^6}{3^1} = 3^5$$

REF: 061219ia STA: A.A.12 TOP: Division of Powers

233 ANS: 3 REF: 061230ia STA: A.S.9

TOP: Frequency Histograms, Bar Graphs and Tables

234 ANS: 4 REF: 061221ia STA: A.G.4 TOP: Identifying the Equation of a Graph

235 ANS: 3 REF: 081103ia STA: A.A.30 TOP: Set Theory

236 ANS: 4

If $m\angle C = 90$, then \overline{AB} is the hypotenuse, and the triangle is a 3-4-5 triangle.

REF: 061224ia STA: A.A.42 TOP: Trigonometric Ratios

237 ANS: 1 REF: 011207ia STA: A.G.9 TOP: Quadratic-Linear Systems

238 ANS: 1 REF: 081204ia STA: A.S.12 TOP: Scatter Plots

239 ANS: 2 REF: 061229ia STA: A.A.9 TOP: Exponential Functions

240 ANS: 4 REF: 061222ia STA: A.A.40 TOP: Systems of Linear Inequalities

241 ANS: 4

The transformation is a reflection in the x -axis.

REF: 011206ia STA: A.G.5 TOP: Graphing Absolute Value Functions

242 ANS: 4

$$\frac{9.2 \times 10^6}{2.3 \times 10^2} = 4 \times 10^4$$

REF: 081006ia STA: A.N.4 TOP: Operations with Scientific Notation

243 ANS: 1

$$\left| \frac{4(-6) + 18}{4!} \right| = \left| \frac{-6}{24} \right| = \frac{1}{4}$$

REF: 081220ia STA: A.N.6 TOP: Evaluating Expressions

244 ANS: 2 REF: 081111ia STA: A.G.10

TOP: Identifying the Vertex of a Quadratic Given Graph

245 ANS: 3

$$x = \frac{-b}{2a} = \frac{-24}{2(-2)} = 6. \quad y = -2(6)^2 + 24(6) - 100 = -28$$

REF: 061214ia STA: A.A.41 TOP: Identifying the Vertex of a Quadratic Given Equation

246 ANS: 2 REF: 081218ia STA: A.G.5 TOP: Graphing Quadratic Functions

247 ANS: 1 REF: 061220ia STA: A.A.17 TOP: Addition and Subtraction of Rationals

248 ANS: 2

The other sets of data are qualitative.

REF: 011211ia STA: A.S.1 TOP: Analysis of Data

249 ANS: 2 REF: 081223ia STA: A.A.32 TOP: Slope

250 ANS: 3

$$2\sqrt{45} = 2\sqrt{9}\sqrt{5} = 6\sqrt{5}$$

REF: 011203ia STA: A.N.2 TOP: Simplifying Radicals

251 ANS: 4 REF: 011222ia STA: A.A.29 TOP: Set Theory

252 ANS: 1 REF: 011202ia STA: A.A.9 TOP: Exponential Functions

253 ANS: 3

$$b = 3 + d \quad (3 + d)d = 40$$

$$bd = 40 \quad d^2 + 3d - 40 = 0$$

$$(d + 8)(d - 5) = 0$$

$$d = 5$$

REF: 011208ia STA: A.A.8 TOP: Writing Quadratics

254 ANS: 4

$$2(2) - (-7) = 11$$

REF: 081217ia STA: A.A.39 TOP: Identifying Points on a Line

255 ANS: 3 REF: 011220ia STA: A.S.6 TOP: Box-and-Whisker Plots

256 ANS: 3

$$A \cup C = \{1, 2, 3, 5, 7, 9\}$$

REF: 081221ia STA: A.A.31 TOP: Set Theory

257 ANS: 1 REF: 011210ia STA: A.G.6 TOP: Linear Inequalities

258 ANS: 4

$$V = \pi r^2 h$$

$$32\pi = \pi r^2(2)$$

$$16 = r^2$$

$$4 = r$$

REF: 081224ia STA: A.G.2 TOP: Volume

259 ANS: 4

$$3y + 2x = 8$$

$$3(-2) + 2(7) = 8$$

$$-6 + 14 = 8$$

REF: 011218ia STA: A.A.39 TOP: Identifying Points on a Line

260 ANS: 1

$$\sqrt{1700^2 - 1300^2} \approx 1095$$

REF: 011221ia STA: A.A.45 TOP: Pythagorean Theorem

261 ANS: 3 REF: 061218ia STA: A.S.20 TOP: Geometric Probability

262 ANS: 2
 $W + L = 72$
 $W - L = 12$
 $2W = 84$
 $W = 42$

REF: 081227ia STA: A.A.7 TOP: Writing Linear Systems

263 ANS: 3 REF: 011205ia STA: A.A.1 TOP: Expressions

264 ANS: 3 REF: 081201ia STA: A.G.7 TOP: Solving Linear Systems

265 ANS: 4 REF: 061226ia STA: A.A.13 TOP: Addition and Subtraction of Polynomials

KEY: subtraction

266 ANS: 4

$$\frac{2x^2(x^4 - 9x^2 + 1)}{2x^2}$$

REF: 081222ia STA: A.A.16 TOP: Rational Expressions

KEY: $a > 0$

267 ANS: 1
 $4 + 6 + 10 + \frac{6\pi}{2} = 20 + 3\pi$

REF: 081228ia STA: A.G.1 TOP: Compositions of Polygons and Circles

KEY: perimeter

268 ANS: 3 REF: 081230ia STA: A.A.23 TOP: Transforming Formulas

269 ANS: 4
 $375 + 155w \geq 900$
 $155w \geq 525$
 $w \geq 3.4$

REF: 081206ia STA: A.A.6 TOP: Modeling Inequalities

270 ANS: 4 REF: 011229ia STA: A.S.8 TOP: Scatter Plots

Integrated Algebra Multiple Choice Regents Exam Questions Answer Section

271 ANS: 3

$$500(1 + 0.06)^3 \approx 596$$

REF: 080929ia STA: A.A.9 TOP: Exponential Functions

272 ANS: 4

$$P(G \text{ or } W) = \frac{4}{8}, P(G \text{ or } B) = \frac{3}{8}, P(Y \text{ or } B) = \frac{4}{8}, P(Y \text{ or } G) = \frac{5}{8}$$

REF: 060802ia STA: A.S.22 TOP: Geometric Probability

273 ANS: 3 REF: fall0706ia STA: A.A.19

TOP: Factoring the Difference of Perfect Squares

274 ANS: 3

$$(3 - 1) \times 2 \times 3 = 12$$

REF: 080905ia STA: A.N.7 TOP: Conditional Probability

275 ANS: 2

The events are not mutually exclusive: $P(\text{prime}) = \frac{3}{6}$, $P(\text{even}) = \frac{3}{6}$, $P(\text{prime AND even}) = \frac{1}{6}$

$$P(\text{prime OR even}) = \frac{3}{6} + \frac{3}{6} - \frac{1}{6} = \frac{5}{6}$$

REF: 080830ia STA: A.S.23 TOP: Theoretical Probability

KEY: not mutually exclusive events

276 ANS: 3

$$35000(1 - 0.05)^4 \approx 28507.72$$

REF: fall0719ia STA: A.A.9 TOP: Exponential Functions

277 ANS: 1

$$x - 2y = 1$$

$$x + 4y = 7$$

$$-6y = -6$$

$$y = 1$$

REF: 080920ia STA: A.A.10 TOP: Solving Linear Systems

278 ANS: 4 REF: 010930ia STA: A.G.3 TOP: Defining Functions

279 ANS: 2
 $L + S = 47$
 $L - S = 15$
 $2L = 62$
 $L = 31$

REF: 060912ia STA: A.A.7 TOP: Writing Linear Systems

280 ANS: 2
 $1.5^3 = 3.375$

REF: 060809ia STA: A.G.2 TOP: Volume

281 ANS: 4 REF: 010927ia STA: A.N.4 TOP: Operations with Scientific Notation

282 ANS: 2
 $l(l - 5) = 24$
 $l^2 - 5l - 24 = 0$
 $(l - 8)(l + 3) = 0$
 $l = 8$

REF: 080817ia STA: A.A.8 TOP: Geometric Applications of Quadratics

283 ANS: 1
 $-2x + 5 > 17$
 $-2x > 12$
 $x < -6$

REF: fall0724ia STA: A.A.21 TOP: Interpreting Solutions

284 ANS: 1
 ${}_4P_4 = 4 \times 3 \times 2 \times 1 = 24$

REF: 080816ia STA: A.N.8 TOP: Permutations

285 ANS: 1 REF: fall0723ia STA: A.M.3 TOP: Error
 KEY: area

286 ANS: 3 REF: fall0705ia STA: A.N.1 TOP: Identifying Properties

287 ANS: 3
 $5x + 2y = 48$
 $3x + 2y = 32$
 $2x = 16$
 $x = 8$

REF: fall0708ia STA: A.A.10 TOP: Solving Linear Systems

288 ANS: 1 REF: 060807ia STA: A.A.13 TOP: Multiplication of Polynomials

289 ANS: 3

$$\sin A = \frac{10}{16} \quad B = 180 - (90 + 38.7) = 51.3. \quad \text{A } 90^\circ \text{ angle is not acute.}$$

$$A \approx 38.7$$

REF: 080829ia STA: A.A.43 TOP: Using Trigonometry to Find an Angle

290 ANS: 4 REF: 060930ia STA: A.A.29 TOP: Set Theory

291 ANS: 1

$$8^2 + 15^2 = c^2$$

$$c^2 = 289$$

$$c = 17$$

REF: 080906ia STA: A.A.45 TOP: Pythagorean Theorem

292 ANS: 1

$$\frac{4}{3}x + 5 < 17$$

$$\frac{4}{3}x < 12$$

$$4x < 36$$

$$x < 9$$

REF: 060914ia STA: A.A.21 TOP: Interpreting Solutions

293 ANS: 3 REF: 080907ia STA: A.S.20 TOP: Geometric Probability

294 ANS: 3

The other situations are quantitative.

REF: 060905ia STA: A.S.1 TOP: Analysis of Data

295 ANS: 1 REF: 080911ia STA: A.A.36 TOP: Parallel and Perpendicular Lines

296 ANS: 1 REF: 060811ia STA: A.G.10

TOP: Identifying the Vertex of a Quadratic Given Graph

297 ANS: 3

$$3^2 + 5^2 = x^2$$

$$34 = x^2$$

$$\sqrt{34} = x$$

REF: 060909ia STA: A.A.45 TOP: Pythagorean Theorem

298 ANS: 1 REF: 080924ia STA: A.G.1 TOP: Compositions of Polygons and Circles

KEY: perimeter

299 ANS: 4 REF: fall0704ia STA: A.A.29 TOP: Set Theory

300 ANS: 4

$$\frac{(d \times 3) + (2 \times 2d)}{2 \times 3} = \frac{3d + 4d}{6} = \frac{7d}{6}$$

REF: fall0727ia STA: A.A.17 TOP: Addition and Subtraction of Rationals

301 ANS: 1 REF: 060903ia STA: A.A.12 TOP: Division of Powers

302 ANS: 2

The set of integers greater than -2 and less than 6 is $\{-1, 0, 1, 2, 3, 4, 5\}$. The subset of this set that is the positive factors of 5 is $\{1, 5\}$. The complement of this subset is $\{-1, 0, 2, 3, 4\}$.

REF: 060818ia STA: A.A.30 TOP: Set Theory

303 ANS: 4

$$-2(x - 5) < 4$$

$$-2x + 10 < 4$$

$$-2x < -6$$

$$x > 3$$

REF: 080913ia STA: A.A.21 TOP: Interpreting Solutions

304 ANS: 1 REF: 080902ia STA: A.A.19

TOP: Factoring the Difference of Perfect Squares

305 ANS: 1 REF: 010905ia STA: A.G.4 TOP: Families of Functions

306 ANS: 1

$30^2 + 40^2 = c^2$. 30, 40, 50 is a multiple of 3, 4, 5.

$$2500 = c^2$$

$$50 = c$$

REF: fall0711ia STA: A.A.45 TOP: Pythagorean Theorem

307 ANS: 3

The value of the third quartile is the last vertical line of the box.

REF: 080818ia STA: A.S.6 TOP: Box-and-Whisker Plots

308 ANS: 1 REF: fall0728ia STA: A.A.15 TOP: Undefined Rationals

309 ANS: 4

$$16^2 + b^2 = 34^2$$

$$b^2 = 900$$

$$b = 30$$

REF: 080809ia STA: A.A.45 TOP: Pythagorean Theorem

310 ANS: 4 REF: 080825ia STA: A.A.40 TOP: Systems of Linear Inequalities

311 ANS: 2 REF: 010909ia STA: A.A.19

TOP: Factoring the Difference of Perfect Squares

312 ANS: 4

$$\frac{344 \text{ m}}{\text{sec}} \times \frac{60 \text{ sec}}{1 \text{ min}} \times \frac{60 \text{ min}}{1 \text{ hr}} = 1,238,400 \frac{\text{m}}{\text{hr}}$$

REF: 060911ia STA: A.M.2 TOP: Conversions KEY: dimensional analysis

313 ANS: 2

$$\sin U = \frac{\text{opposite}}{\text{hypotenuse}} = \frac{15}{17}$$

REF: 010919ia STA: A.A.42 TOP: Trigonometric Ratios

314 ANS: 2 REF: fall0725ia STA: A.N.4 TOP: Operations with Scientific Notation

315 ANS: 1

$$\frac{\sqrt{32}}{4} = \frac{\sqrt{16}\sqrt{2}}{4} = \sqrt{2}$$

REF: 060828ia STA: A.N.2 TOP: Simplifying Radicals

316 ANS: 4

Let x = youngest brother and $x + 4$ = oldest brother. $3x - (x + 4) = 48$.

$$2x - 4 = 48$$

$$x = 26$$

REF: 080928ia STA: A.A.6 TOP: Modeling Equations

317 ANS: 3

$$|-5(5) + 12| = |-13| = 13$$

REF: 080923ia STA: A.N.6 TOP: Evaluating Expressions

318 ANS: 4

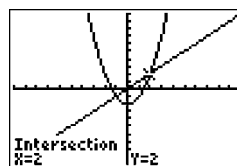

$$x^2 - 2 = x \quad \text{Since } y = x, \text{ the solutions are } (2, 2) \text{ and } (-1, -1).$$

$$x^2 - x - 2 = 0$$

$$(x - 2)(x + 1) = 0$$

$$x = 2 \text{ or } -1$$

REF: 060810ia STA: A.A.11 TOP: Quadratic-Linear Systems

319 ANS: 2

$$2x^2 + 10x - 12 = 2(x^2 + 5x - 6) = 2(x + 6)(x - 1)$$

REF: 080806ia STA: A.A.20 TOP: Factoring Polynomials

320 ANS: 4

The transformation is a reflection in the x -axis.

REF: fall0722ia STA: A.G.5 TOP: Graphing Absolute Value Functions

321 ANS: 2

If the car can travel 75 miles on 4 gallons, it can travel 300 miles on 16 gallons. $\frac{75}{4} = \frac{x}{16}$.

$$x = 300$$

REF: 080807ia STA: A.G.4 TOP: Graphing Linear Functions

322 ANS: 2

REF: 080802ia

STA: A.N.1

TOP: Identifying Properties

323 ANS: 3

$$a + ar = b + r$$

$$a(1 + r) = b + r$$

$$a = \frac{b + r}{1 + r}$$

REF: 060913ia

STA: A.A.23

TOP: Transforming Formulas

324 ANS: 4

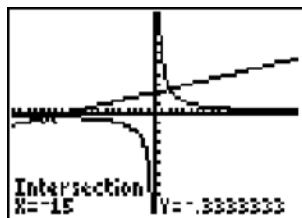

$$\frac{5}{x} = \frac{x + 13}{6}$$

$$x^2 + 13x = 30$$

$$x^2 + 13x - 30 = 0$$

$$(x + 15)(x - 2) = 0$$

$$x = -15 \text{ or } 2$$

REF: 060826ia

STA: A.A.26

TOP: Solving Rationals

325 ANS: 1

$$y = mx + b$$

$$-6 = (-3)(4) + b$$

$$b = 6$$

REF: 060922ia

STA: A.A.34

TOP: Writing Linear Equations

326 ANS: 3

$$3ax + b = c$$

$$3ax = c - b$$

$$x = \frac{c - b}{3a}$$

REF: 080808ia STA: A.A.23 TOP: Transforming Formulas

327 ANS: 1 REF: 060801ia STA: A.G.4 TOP: Families of Functions

328 ANS: 3

$$0.75 \text{ hours} = 45 \text{ minutes. } \frac{120}{1} = \frac{x}{45}$$

$$x = 5400$$

REF: 080814ia STA: A.M.1 TOP: Using Rate

329 ANS: 3 REF: fall0710ia STA: A.A.31 TOP: Set Theory

330 ANS: 3

$$\cos 30 = \frac{x}{24}$$

$$x \approx 21$$

REF: 010912ia STA: A.A.44 TOP: Using Trigonometry to Find a Side

331 ANS: 1 REF: 080813ia STA: A.G.10

TOP: Identifying the Vertex of a Quadratic Given Graph

332 ANS: 1

$$\left| \frac{289 - 282}{289} \right| \approx 0.024$$

REF: 080828ia STA: A.M.3 TOP: Error KEY: volume and surface area

333 ANS: 2 REF: fall0701ia STA: A.S.7 TOP: Scatter Plots

334 ANS: 2 REF: 060923ia STA: A.A.13 TOP: Addition and Subtraction of Polynomials

KEY: subtraction

335 ANS: 2

$$\frac{2x^2 - 12x}{x - 6} = \frac{2x(x - 6)}{x - 6} = 2x$$

REF: 060824ia STA: A.A.16 TOP: Rational Expressions

KEY: $a > 0$

336 ANS: 4

$$P(O) = \frac{3}{6}, P(E) = \frac{3}{6}, P(< 6) = \frac{5}{6}, P(> 4) = \frac{2}{6}$$

REF: 010903ia STA: A.S.22 TOP: Theoretical Probability

- 337 ANS: 4
 $SA = 2lw + 2hw + 2lh = 2(3)(1.5) + 2(2)(1.5) + 2(3)(2) = 27$
- REF: 060827ia STA: A.G.2 TOP: Surface Area
- 338 ANS: 3
 $x^2 - 6x = 0$
 $x(x - 6) = 0$
 $x = 0$ $x = 6$
- REF: 080921ia STA: A.A.27 TOP: Solving Quadratics by Factoring
- 339 ANS: 4
 $\frac{\text{distance}}{\text{time}} = \frac{24}{6} = 4$
- REF: 010902ia STA: A.M.1 TOP: Speed
- 340 ANS: 4 REF: 010908ia STA: A.A.9 TOP: Exponential Functions
- 341 ANS: 4
 $A = \{2, 4, 6, 8, 10, 12, 14, 16, 18, 20\}$
- REF: 080912ia STA: A.A.30 TOP: Set Theory
- 342 ANS: 1 REF: 080803ia STA: A.A.4 TOP: Modeling Inequalities
- 343 ANS: 4 REF: 080903ia STA: A.A.12 TOP: Multiplication of Powers
- 344 ANS: 2
 $\tan 32 = \frac{x}{25}$
 $x \approx 15.6$
- REF: 080914ia STA: A.A.44 TOP: Using Trigonometry to Find a Side
- 345 ANS: 1 REF: 080824ia STA: A.A.43 TOP: Using Trigonometry to Find an Angle
- 346 ANS: 3
The value of the upper quartile is the last vertical line of the box.
- REF: 060915ia STA: A.S.6 TOP: Box-and-Whisker Plots
- 347 ANS: 2
 $\frac{3}{2x} + \frac{4}{3x} = \frac{9x + 8x}{6x^2} = \frac{17x}{6x^2} = \frac{17}{6x}$
- REF: 080917ia STA: A.A.17 TOP: Addition and Subtraction of Rationals
- 348 ANS: 1
 $\frac{4x}{x-1} \cdot \frac{x^2-1}{3x+3} = \frac{4x}{x-1} \cdot \frac{(x+1)(x-1)}{3(x+1)} = \frac{4x}{3}$
- REF: 080826ia STA: A.A.18 TOP: Multiplication and Division of Rationals
KEY: multiplication
- 349 ANS: 4 REF: 060927ia STA: A.N.4 TOP: Operations with Scientific Notation

350 ANS: 4 REF: 080827ia STA: A.A.12 TOP: Powers of Powers

351 ANS: 4

$$y = mx + b$$

$$-1 = (2)(3) + b$$

$$b = -7$$

REF: 080927ia STA: A.A.34 TOP: Writing Linear Equations

352 ANS: 3

$$25 - 18 = 7$$

REF: 060822ia STA: A.S.9 TOP: Frequency Histograms, Bar Graphs and Tables

353 ANS: 3

The other situations are quantitative.

REF: 060819ia STA: A.S.1 TOP: Analysis of Data

354 ANS: 3 REF: 060825ia STA: A.A.45 TOP: Pythagorean Theorem

355 ANS: 1 REF: 060920ia STA: A.G.6 TOP: Linear Inequalities

356 ANS: 1

To determine student interest, survey the widest range of students.

REF: 060803ia STA: A.S.3 TOP: Analysis of Data

357 ANS: 2

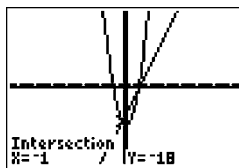

$$x^2 - x - 20 = 3x - 15 \quad y = 3x - 15$$

$$x^2 - 4x - 6 = 0 \quad = 3(-1) - 15$$

$$(x - 5)(x + 1) = 0 \quad = -18$$

$$x = 5 \text{ or } -1$$

REF: 010922ia STA: A.A.11 TOP: Quadratic-Linear Systems

358 ANS: 3

$$m = \frac{1 - (-4)}{-6 - 4} = -\frac{1}{2}$$

REF: 060820ia STA: A.A.33 TOP: Slope

359 ANS: 1

$$0.07m + 19 \leq 29.50$$

$$0.07m \leq 10.50$$

$$m \leq 150$$

REF: 010904ia STA: A.A.6 TOP: Modeling Inequalities

360 ANS: 3 REF: 010910ia STA: A.A.35 TOP: Writing Linear Equations

361 ANS: 3 REF: 060924ia STA: A.G.8 TOP: Solving Quadratics by Graphing

362 ANS: 1
The slope of both is -4 .

REF: 060814ia STA: A.A.38 TOP: Parallel and Perpendicular Lines

363 ANS: 3 REF: fall0702ia STA: A.S.23 TOP: Theoretical Probability

KEY: mutually exclusive events

364 ANS: 4 REF: fall0729ia STA: A.A.2 TOP: Expressions

365 ANS: 1 REF: 060804ia STA: A.A.19

TOP: Factoring the Difference of Perfect Squares

366 ANS: 2

$$\frac{9x^4 - 27x^6}{3x^3} = \frac{9x^4(1 - 3x^2)}{3x^3} = 3x(1 - 3x^2)$$

REF: fall0718ia STA: A.A.16 TOP: Rational Expressions

KEY: $a > 0$

367 ANS: 2

The two values are shoe size and height.

REF: fall0714ia STA: A.S.2 TOP: Analysis of Data

368 ANS: 1

$$\sin C = \frac{\text{opposite}}{\text{hypotenuse}} = \frac{13}{85}$$

REF: fall0721ia STA: A.A.42 TOP: Trigonometric Ratios

369 ANS: 1

$$\frac{2}{x} - 3 = \frac{26}{x}$$

$$-3 = \frac{24}{x}$$

$$x = -8$$

REF: 010918ia STA: A.A.26 TOP: Solving Rationals

370 ANS: 2

$$x + 2y = 9$$

$$x - y = 3$$

$$3y = 6$$

$$y = 2$$

REF: 060925ia STA: A.A.10 TOP: Solving Linear Systems

371 ANS: 4 REF: fall0717ia STA: A.G.4 TOP: Families of Functions

372 ANS: 1

$$x = \frac{-b}{2a} = \frac{-(-16)}{2(1)} = 8. \quad y = (8)^2 - 16(8) + 63 = -1$$

REF: 060918ia STA: A.A.41 TOP: Identifying the Vertex of a Quadratic Given Equation

373 ANS: 2

$$\sin A = \frac{8}{12}$$

$$A \approx 42$$

REF: 060816ia STA: A.A.43 TOP: Using Trigonometry to Find an Angle

374 ANS: 2

$$3c + 4m = 12.50$$

$$3c + 2m = 8.50$$

$$2m = 4.00$$

$$m = 2.00$$

REF: 060806ia STA: A.A.7 TOP: Writing Linear Systems

375 ANS: 2

$$\sqrt{32} = \sqrt{16} \sqrt{2} = 4\sqrt{2}$$

REF: 060910ia STA: A.N.2 TOP: Simplifying Radicals

376 ANS: 2

$$\frac{3}{5}(x + 2) = x - 4$$

$$3(x + 2) = 5(x - 4)$$

$$3x + 6 = 5x - 20$$

$$26 = 2x$$

$$x = 13$$

REF: 080909ia STA: A.A.25 TOP: Solving Equations with Fractional Expressions

377 ANS: 2

REF: 080916ia STA: A.G.8 TOP: Solving Quadratics by Graphing

378 ANS: 1

$$m = \frac{4 - (-4)}{-5 - 15} = -\frac{2}{5}$$

REF: 080915ia STA: A.A.33 TOP: Slope

379 ANS: 2

$$\frac{6}{5x} - \frac{2}{3x} = \frac{18x - 10x}{15x^2} = \frac{8x}{15x^2} = \frac{8}{15x}$$

REF: 010921ia STA: A.A.17 TOP: Addition and Subtraction of Rationals

380 ANS: 1

$$m = \frac{3-0}{0-2} = -\frac{3}{2}. \text{ Using the given y-intercept } (0,3) \text{ to write the equation of the line } y = -\frac{3}{2}x + 3.$$

REF: fall0713ia STA: A.A.35 TOP: Writing Linear Equations

381 ANS: 3

$$x^2 - 10x + 21 = 0$$

$$(x-7)(x-3) = 0$$

$$x = 7 \quad x = 3$$

REF: 010914ia STA: A.A.28 TOP: Roots of Quadratics

382 ANS: 4

$$-4x + 2 > 10$$

$$-4x > 8$$

$$x < -2$$

REF: 080805ia STA: A.A.21 TOP: Interpreting Solutions

383 ANS: 2

REF: 080930ia STA: A.S.17 TOP: Scatter Plots

384 ANS: 4

$$25(x-3) = 25x - 75$$

REF: 060823ia STA: A.A.1 TOP: Expressions

385 ANS: 2

$$\left| \frac{149.6 - 174.2}{149.6} \right| \approx 0.1644$$

REF: 080926ia STA: A.M.3 TOP: Error KEY: area

386 ANS: 4

REF: fall0715ia STA: A.A.5 TOP: Modeling Inequalities

387 ANS: 2

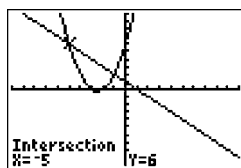

$$x^2 + 5x + 6 = -x + 1. \quad y = -x + 1$$

$$x^2 + 6x + 5 = 0 \quad = -(-5) + 1$$

$$(x+5)(x+1) = 0 \quad = 6$$

$$x = -5 \text{ or } -1$$

REF: 080812ia STA: A.A.11 TOP: Quadratic-Linear Systems

388 ANS: 1

A rooster crows before sunrise, not because of the sun.

REF: fall0707ia STA: A.S.14 TOP: Analysis of Data

389 ANS: 4



REF: 080822ia STA: A.S.8 TOP: Scatter Plots

390 ANS: 1

$$so = f + 60 \quad j = 2f - 50 \quad se = 3f. \quad f + (f + 60) + (2f - 50) + 3f = 1424$$

$$7f + 10 = 1424$$

$$f = 202$$

REF: 060917ia STA: A.A.7 TOP: Writing Linear Systems

391 ANS: 4

$$V = \pi r^2 h = \pi \cdot 6^2 \cdot 15 \approx 1696.5$$

REF: fall0712ia STA: A.G.2 TOP: Volume

392 ANS: 4 REF: 060829ia STA: A.G.5 TOP: Graphing Quadratic Functions

393 ANS: 4

$$x^2 - 7x + 6 = 0$$

$$(x - 6)(x - 1) = 0$$

$$x = 6 \quad x = 1$$

REF: 060902ia STA: A.A.28 TOP: Roots of Quadratics

394 ANS: 2 REF: 010925ia STA: A.A.15 TOP: Undefined Rationals

395 ANS: 3 REF: 080819ia STA: A.A.13 TOP: Addition and Subtraction of Polynomials

KEY: subtraction

396 ANS: 2 REF: 080823ia STA: A.A.32 TOP: Slope

397 ANS: 4

Surveying persons leaving a football game about a sports budget contains the most bias.

REF: 080910ia STA: A.S.3 TOP: Analysis of Data

398 ANS: 3

$$b = 42 - r \quad r = 2b + 3$$

$$r = 2b + 3 \quad r = 2(42 - r) + 3$$

$$r = 84 - 2r + 3$$

$$3r = 87$$

$$r = 29$$

REF: 060812ia STA: A.A.7 TOP: Writing Linear Systems

399 ANS: 4 REF: fall0730ia STA: A.G.3 TOP: Defining Functions

400 ANS: 2 REF: 010916ia STA: A.G.10
TOP: Identifying the Vertex of a Quadratic Given Graph

401 ANS: 4 REF: 060906ia STA: A.A.4 TOP: Modeling Inequalities

402 ANS: 2
The median score, 10, is the vertical line in the center of the box.

REF: fall0709ia STA: A.S.5 TOP: Box-and-Whisker Plots

403 ANS: 4
$$\frac{x^2 - 1}{x + 1} \cdot \frac{x + 3}{3x - 3} = \frac{(x + 1)(x - 1)}{x + 1} \cdot \frac{x + 3}{3(x - 1)} = \frac{x + 3}{3}$$

REF: 060815ia STA: A.A.18 TOP: Multiplication and Division of Rationals
KEY: multiplication

404 ANS: 3
$$m = \frac{4 - 10}{3 - (-6)} = -\frac{2}{3}$$

REF: fall0716ia STA: A.A.33 TOP: Slope
405 ANS: 2 REF: 080901ia STA: A.A.4 TOP: Modeling Equations

406 ANS: 3
$$F = \frac{9}{5}C + 32 = \frac{9}{5}(15) + 32 = 59$$

REF: 010901ia STA: A.M.2 TOP: Conversions KEY: formula
407 ANS: 4

$$A = lw = (3w - 7)(w) = 3w^2 - 7w$$

REF: 010924ia STA: A.A.1 TOP: Expressions
408 ANS: 4

$$w(w + 5) = 36$$

$$w^2 + 5w - 36 = 0$$

REF: fall0726ia STA: A.A.5 TOP: Modeling Equations
409 ANS: 1

Everyone eats, can shop in malls and wear clothes. People who work in a sporting goods store probably watch more sports television than most.

REF: 010923ia STA: A.S.3 TOP: Analysis of Data
410 ANS: 2 REF: 080815ia STA: A.G.1 TOP: Compositions of Polygons and Circles
KEY: area

411 ANS: 3
$$\sqrt{72} = \sqrt{36} \sqrt{2} = 6\sqrt{2}$$

REF: 010920ia STA: A.N.2 TOP: Simplifying Radicals
412 ANS: 2 REF: 010915ia STA: A.A.5 TOP: Modeling Equations

413 ANS: 2 REF: 060908ia STA: A.S.21 TOP: Empirical Probability

414 ANS: 4

$$\frac{2^6}{2^1} = 2^5$$

REF: 060813ia STA: A.A.12 TOP: Division of Powers

415 ANS: 4 REF: 060805ia STA: A.S.12 TOP: Scatter Plots

416 ANS: 3 REF: 060808ia STA: A.N.8 TOP: Permutations

417 ANS: 1

$$13.95 + 0.49s \leq 50.00$$

$$0.49s \leq 36.05$$

$$s \leq 73.57$$

REF: 080904ia STA: A.A.6 TOP: Modeling Inequalities

418 ANS: 2 REF: 060830ia STA: A.A.9 TOP: Exponential Functions

419 ANS: 2

$$5\sqrt{20} = 5\sqrt{4}\sqrt{5} = 10\sqrt{5}$$

REF: 080922ia STA: A.N.2 TOP: Simplifying Radicals

420 ANS: 2

$$m = \frac{5-3}{2-7} = -\frac{2}{5}$$

REF: 010913ia STA: A.A.33 TOP: Slope

421 ANS: 3 REF: 080925ia STA: A.G.4 TOP: Identifying the Equation of a Graph

422 ANS: 4 REF: 060916ia STA: A.A.15 TOP: Undefined Rationals

423 ANS: 3

An element of the domain, 1, is paired with two different elements of the range, 3 and 7.

REF: 080919ia STA: A.G.3 TOP: Defining Functions

424 ANS: 2 REF: 060821ia STA: A.A.5 TOP: Modeling Inequalities

425 ANS: 3

mean = 6, median = 6 and mode = 7

REF: 080804ia STA: A.S.4 TOP: Central Tendency

426 ANS: 3

The number of correct answers on a test causes the test score.

REF: 080908ia STA: A.S.13 TOP: Analysis of Data

427 ANS: 1

The slope of $y = 3 - 2x$ is -2 . Using $m = -\frac{A}{B}$, the slope of $4x + 2y = 5$ is $-\frac{4}{2} = -2$.

REF: 010926ia STA: A.A.38 TOP: Parallel and Perpendicular Lines

428 ANS: 2

The slope of the inequality is $-\frac{1}{2}$.

REF: fall0720ia STA: A.G.6 TOP: Linear Inequalities

429 ANS: 4 REF: 010929ia STA: A.S.6 TOP: Box-and-Whisker Plots

430 ANS: 4

$$\frac{5}{45} = \frac{8}{x}$$

$$5x = 360$$

$$x = 72$$

REF: 060901ia STA: A.M.1 TOP: Speed

431 ANS: 3

$$\frac{(2x^3)(8x^5)}{4x^6} = \frac{16x^8}{4x^6} = 4x^2$$

REF: fall0703ia STA: A.A.12 TOP: Division of Powers

432 ANS: 3 REF: 010917ia STA: A.A.29 TOP: Set Theory

433 ANS: 3

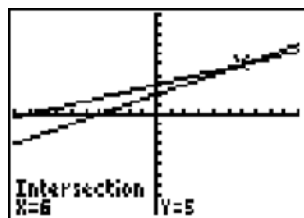

$$\frac{k+4}{2} = \frac{k+9}{3}$$

$$3(k+4) = 2(k+9)$$

$$3k + 12 = 2k + 18$$

$$k = 6$$

REF: 010906ia STA: A.A.26 TOP: Solving Rationals

434 ANS: 2

$$P = 2l + 2w$$

$$P - 2l = 2w$$

$$\frac{P - 2l}{2} = w$$

REF: 010911ia STA: A.A.23 TOP: Transforming Formulas

435 ANS: 4

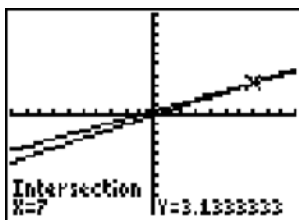

$$\frac{2x}{5} + \frac{1}{3} = \frac{7x-2}{15}$$

$$\frac{(2x \times 3) + (5 \times 1)}{5 \times 3} = \frac{7x-2}{15}$$

$$\frac{6x+5}{15} = \frac{7x-2}{15}$$

$$6x+5 = 7x-2$$

$$x = 7$$

REF: 080820ia STA: A.A.25 TOP: Solving Equations with Fractional Expressions

436 ANS: 1

$$\frac{1}{8} \times \frac{1}{8} = \frac{1}{64}$$

REF: 010928ia STA: A.S.23 TOP: Geometric Probability

437 ANS: 2 REF: 080810ia STA: A.A.36 TOP: Parallel and Perpendicular Lines

438 ANS: 1

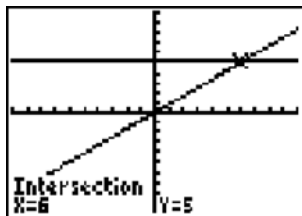

$$\frac{(2x \times 6) + (3 \times x)}{3 \times 6} = 5$$

$$\frac{12x+3x}{18} = 5$$

$$15x = 90$$

$$x = 6$$

REF: 060907ia STA: A.A.25 TOP: Solving Equations with Fractional Expressions

439 ANS: 4

The mean is $80.\bar{6}$, the median is 84.5 and the mode is 87.

REF: 010907ia STA: A.S.4 TOP: Central Tendency

440 ANS: 4

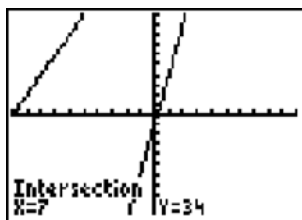

$$5p - 1 = 2p + 20$$

$$3p = 21$$

$$p = 7$$

REF: 080801ia STA: A.A.22 TOP: Solving Equations

441 ANS: 2

The volume of the cube using Ezra's measurements is 8 (2^3). The actual volume is 9.261 (2.1^3). The relative error

$$\text{is } \left| \frac{9.261 - 8}{9.261} \right| \approx 0.14.$$

REF: 060928ia STA: A.M.3 TOP: Error KEY: volume and surface area

442 ANS: 1

$$x^2 + 7x + 10 = 0$$

$$(x + 5)(x + 2) = 0$$

$$x = -5 \text{ or } -2$$

REF: 080918ia STA: A.A.15 TOP: Undefined Rationals

443 ANS: 2

$$\frac{6}{4a} - \frac{2}{3a} = \frac{18a - 8a}{12a^2} = \frac{10a}{12a^2} = \frac{5}{6a}$$

REF: 060929ia STA: A.A.17 TOP: Addition and Subtraction of Rationals

444 ANS: 3 REF: 060926ia STA: A.N.1 TOP: Properties of Reals

445 ANS: 2

$$s + o = 126. \quad s + 2s = 126$$

$$o = 2s \quad s = 42$$

REF: 080811ia STA: A.A.7 TOP: Writing Linear Systems

446 ANS: 3 REF: 060919ia STA: A.G.3 TOP: Defining Functions

447 ANS: 4

$$\frac{25x - 125}{x^2 - 25} = \frac{25(x - 5)}{(x + 5)(x - 5)} = \frac{25}{x + 5}$$

REF: 080821ia STA: A.A.16 TOP: Rational Expressions

KEY: $a > 0$

448 ANS: 3 REF: 060817ia STA: A.A.15 TOP: Undefined Rationals

449 ANS: 2 REF: 060904ia STA: A.A.1 TOP: Expressions

450 ANS: 2

$$\frac{x^2 - 2x - 15}{x^2 + 3x} = \frac{(x-5)(x+3)}{x(x+3)} = \frac{x-5}{x}$$

REF: 060921ia STA: A.A.16

TOP: Rational Expressions

KEY: $a > 0$

Integrated Algebra 2 Point Regents Exam Questions Answer Section

451 ANS:

$$\frac{3k^2m^6}{4}$$

PTS: 2 REF: 010932ia STA: A.A.12 TOP: Division of Powers

452 ANS:

$36 - 9\pi$. 15.6. Area of square—area of 4 quarter circles. $(3 + 3)^2 - 3^2\pi = 36 - 9\pi$

PTS: 2 REF: 060832ia STA: A.G.1 TOP: Compositions of Polygons and Circles
KEY: area

453 ANS:

$$3a^2b^2 - 6a \cdot \frac{45a^4b^3 - 90a^3b}{15a^2b} = \frac{45a^4b^3}{15a^2b} - \frac{90a^3b}{15a^2b} = 3a^2b^2 - 6a$$

PTS: 2 REF: 081031ia STA: A.A.14 TOP: Division of Polynomials

454 ANS:

$$60. {}_5P_3 = 60$$

PTS: 2 REF: 060931ia STA: A.N.8 TOP: Permutations

455 ANS:

$-6a + 42$. distributive

PTS: 2 REF: 061032ia STA: A.N.1 TOP: Properties of Reals

456 ANS:

$$bc + ac = ab$$

$$c(b + a) = ab$$

$$c = \frac{ab}{b + a}$$

PTS: 2 REF: 081131ia STA: A.A.23 TOP: Transforming Formulas

457 ANS:

$$0 \leq t \leq 40$$

PTS: 2 REF: 060833ia STA: A.A.31 TOP: Set Theory

458 ANS:

White. There are 31 white blocks, 30 red blocks and 29 blue blocks.

PTS: 2 REF: 061232ia STA: A.S.22 TOP: Theoretical Probability

459 ANS:

$\frac{1}{8}$. After the English and social studies books are taken, 8 books are left and 1 is an English book.

PTS: 2 REF: 060933ia STA: A.S.18 TOP: Conditional Probability

460 ANS:

$$4x(x+3)(x-3). \quad 4x^3 - 36x = 4x(x^2 - 9) = 4x(x+3)(x-3)$$

PTS: 2 REF: 060932ia STA: A.A.19
TOP: Factoring the Difference of Perfect Squares

461 ANS:

$$\frac{600 - 592}{592} \approx 0.014$$

PTS: 2 REF: 061031ia STA: A.M.3 TOP: Error
KEY: volume and surface area

462 ANS:

$$\frac{6}{25} \cdot \frac{25 - (11 + 5 + 3)}{25}$$

PTS: 2 REF: 011232ia STA: A.S.21 TOP: Experimental Probability

463 ANS:

$$2,160 \frac{1,200}{25} = \frac{x}{45}$$

$$25x = 54,000$$

$$x = 2,160$$

PTS: 2 REF: 081032ia STA: A.M.1 TOP: Using Rate

464 ANS:

$$53. \sin A = \frac{16}{20}$$

$$A \approx 53$$

PTS: 2 REF: 011032ia STA: A.A.43 TOP: Using Trigonometry to Find an Angle

465 ANS:

$$147.75 \quad 2 \times 5.5 \times 3 + 2 \times 6.75 \times 3 + 2 \times 5.5 \times 6.75 = 147.75$$

PTS: 2 REF: 011231ia STA: A.G.2 TOP: Surface Area

466 ANS:

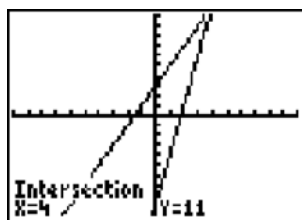

$$4. \quad 3 + 2g = 5g - 9$$

$$12 = 3g$$

$$g = 4$$

PTS: 2 REF: fall0732ia STA: A.A.22 TOP: Solving Equations

467 ANS:

Ann's. $\frac{225}{15} = 15$ mpg is greater than $\frac{290}{23.2} = 12.5$ mpg

PTS: 2 REF: 060831ia STA: A.M.1 TOP: Using Rate

468 ANS:

$d = 6.25h$, 250. $d = 6.25(40) = 250$

PTS: 2 REF: 010933ia STA: A.N.5 TOP: Direct Variation

469 ANS:

(1) Distributive; (2) Commutative

PTS: 2 REF: 061132ia STA: A.N.1 TOP: Identifying Properties

470 ANS:

5. $48 \text{ inches} \times \frac{1 \text{ yard}}{36 \text{ inches}} = \frac{4}{3} \text{ yards} \times \$3.75 = \$5.00$

PTS: 2 REF: 011131ia STA: A.M.2 TOP: Conversions
KEY: dimensional analysis

471 ANS:

50. $12 + 10 + 12 + \frac{1}{2}(10\pi) \approx 50$

PTS: 2 REF: 010931ia STA: A.G.1 TOP: Compositions of Polygons and Circles
KEY: perimeter

472 ANS:

$\frac{x+2}{2} \times \frac{4(x+5)}{(x+4)(x+2)} = \frac{2(x+5)}{x+4}$

PTS: 2 REF: 081232ia STA: A.A.18 TOP: Multiplication and Division of Rationals
KEY: multiplication

473 ANS:

$-3\sqrt{48} = -3\sqrt{16}\sqrt{3} = -12\sqrt{3}$

PTS: 2 REF: 081033ia STA: A.N.2 TOP: Simplifying Radicals

474 ANS:

2.1. $\cos 65 = \frac{x}{5}$

$x \approx 2.1$

PTS: 2 REF: 011133ia STA: A.A.44 TOP: Using Trigonometry to Find a Side

475 ANS:

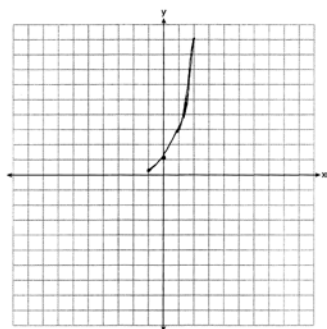

PTS: 2

REF: 081233ia

STA: A.G.4

TOP: Graphing Exponential Functions

476 ANS:

$$\text{orchestra: } \frac{3}{26} > \frac{4}{36}$$

PTS: 2

REF: 011033ia

STA: A.S.22

TOP: Theoretical Probability

477 ANS:

$$x = 1; (1, -5)$$

PTS: 2

REF: 061133ia

STA: A.G.10

TOP: Identifying the Vertex of a Quadratic Given Graph

478 ANS:

$$\frac{x^2 - 5x - 24}{x - 8} = \frac{(x - 8)(x + 3)}{x - 8} = x + 3$$

PTS: 2

REF: 061131ia

STA: A.A.16

TOP: Rational Expressions

KEY: $a > 0$

479 ANS:

$$30\sqrt{2}. \quad 5\sqrt{72} = 5\sqrt{36}\sqrt{2} = 30\sqrt{2}$$

PTS: 2

REF: fall0731ia

STA: A.N.2

TOP: Simplifying Radicals

480 ANS:

$$111.25. \quad \frac{\text{distance}}{\text{time}} = \frac{89}{0.8} = 111.25$$

PTS: 2

REF: 080831ia

STA: A.M.1

TOP: Speed

481 ANS:

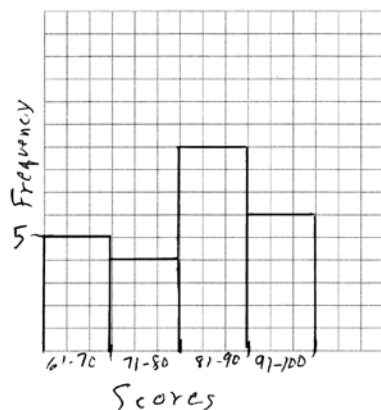

PTS: 2 REF: 081132ia STA: A.S.5

TOP: Frequency Histograms, Bar Graphs and Tables

KEY: frequency histograms

482 ANS:

$$\frac{8100 - 7678.5}{7678.5} \approx 0.055$$

PTS: 2 REF: 061233ia STA: A.M.3

TOP: Error

KEY: area

483 ANS:

$$\frac{1375}{1600} \cdot \frac{40^2 - 15^2}{40^2} = \frac{1375}{1600}$$

PTS: 2 REF: 011132ia STA: A.S.20

TOP: Geometric Probability

484 ANS:

$$\frac{x-1}{x+2} \cdot \frac{x^2-1}{x^2+3x+2} = \frac{(x+1)(x-1)}{(x+2)(x+1)}$$

PTS: 2 REF: 011233ia STA: A.A.16

TOP: Rational Expressions

KEY: $a > 0$

485 ANS:

$$\frac{3}{8} \cdot (H,H,H), (H,H,T), (H,T,H), (\mathbf{H,T,T}), (T,H,H), (\mathbf{T,H,T}), (\mathbf{T,T,H}), (T,T,T)$$

PTS: 2 REF: 080933ia STA: A.S.19

TOP: Sample Space

486 ANS:

16. 12 feet equals 4 yards. $4 \times 4 = 16$.

PTS: 2 REF: 011031ia STA: A.M.2

TOP: Conversions

KEY: dimensional analysis

487 ANS:

2. Subtracting the equations: $3y = 6$

$$y = 2$$

PTS: 2

REF: 061231ia

STA: A.A.10

TOP: Solving Linear Systems

488 ANS:

$$6.56 \times 10^{-2}$$

PTS: 2

REF: 081231ia

STA: A.N.4

TOP: Operations with Scientific Notation

489 ANS:

$$\frac{3}{8} \cdot P(s_1 < 4) \times P(s_2 = \text{back}) = \frac{3}{4} \times \frac{1}{2} = \frac{3}{8}$$

PTS: 2

REF: 080832ia

STA: A.S.23

TOP: Geometric Probability

490 ANS:

$$77120 + 33500 = 110620 \text{ sq. ft.} \times \frac{1 \text{ acre}}{43560 \text{ sq. ft.}} \approx 2.54 \text{ acres}$$

PTS: 2

REF: 081133ia

STA: A.M.2

TOP: Conversions

KEY: dimensional analysis

491 ANS:

{1,2,4,5,9,10,12}

PTS: 2

REF: 080833ia

STA: A.A.30

TOP: Set Theory

492 ANS:

33.4. Serena needs 24 ($9 + 6 + 9$) feet of fencing to surround the rectangular portion of the garden. The length of the fencing needed for the semicircular portion of the garden is $\frac{1}{2} \pi d = 3\pi \approx 9.4$ feet.

PTS: 2

REF: fall0733ia

STA: A.G.1

TOP: Compositions of Polygons and Circles

KEY: perimeter

493 ANS:

$$5,112. (12 \times 30 \times 16) - (6 \times 12 \times 9) = 5112$$

PTS: 2

REF: 080932ia

STA: A.G.2

TOP: Volume

494 ANS:

Not all of the homework problems are equations. The first problem is an expression.

PTS: 2

REF: 080931ia

STA: A.A.3

TOP: Expressions

495 ANS:

$$\sin x = \frac{30}{50}$$

$$x = \sin^{-1} \frac{3}{5}$$

$$x \approx 37$$

PTS: 2

REF: 061033ia

STA: A.A.43

TOP: Using Trigonometry to Find an Angle

Integrated Algebra 3 Point Regents Exam Questions Answer Section

496 ANS:

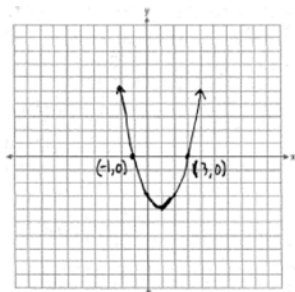

PTS: 3 REF: 060836ia STA: A.G.8 TOP: Solving Quadratics by Graphing

497 ANS:

$$1,512, 1,551.25, 0.025. \quad 36 \times 42 = 1512. \quad 36.5 \times 42.5 = 1551.25. \quad RE = \left| \frac{1512 - 1551.25}{1551.25} \right| \approx 0.025.$$

PTS: 3 REF: 010934ia STA: A.M.3 TOP: Error

KEY: area

498 ANS:

$$2(x+3)(x-4) + 2(5)(x-4) + 2(x+3)(5)$$

$$2(x^2 - 4x + 3x - 12) + 10(x-4) + 10(x+3)$$

$$2x^2 - 2x - 24 + 10x - 40 + 10x + 30$$

$$2x^2 + 18x - 34$$

PTS: 3 REF: 061136ia STA: A.G.2 TOP: Surface Area

499 ANS:

$$\frac{1}{6}, 16.67\%, \$13.50. \quad \frac{18-15}{18} = \frac{1}{6}. \quad 18 \times 0.75 = 13.5$$

PTS: 3 REF: 060835ia STA: A.N.5 TOP: Percents

500 ANS:

$$5,583.86. \quad A = P(1+R)^t = 5000(1+0.0375)^3 \approx 5583.86$$

PTS: 3 REF: 060935ia STA: A.A.9 TOP: Exponential Functions

501 ANS:

$$-2\sqrt{3} \frac{16\sqrt{21}}{2\sqrt{7}} - 5\sqrt{12} = 8\sqrt{3} - 5\sqrt{4}\sqrt{3} = 8\sqrt{3} - 10\sqrt{3} = -2\sqrt{3}$$

PTS: 3 REF: 081136ia STA: A.N.3 TOP: Operations with Radicals

502 ANS:

Greg's rate of 5.5 is faster than Dave's rate of 5.3. $\frac{\text{distance}}{\text{time}} = \frac{11}{2} = 5.5$. $\frac{16}{3} = 5.\bar{3}$

PTS: 3

REF: 080936ia

STA: A.M.1

TOP: Speed

503 ANS:

$$41.8. \sin x = \frac{8}{12}$$

$$A \approx 41.8$$

PTS: 3

REF: 081135ia

STA: A.A.43

TOP: Using Trigonometry to Find an Angle

504 ANS:

$$7. 15x + 22 \geq 120$$

$$x \geq 6.\bar{53}$$

PTS: 3

REF: fall0735ia

STA: A.A.6

TOP: Modeling Inequalities

505 ANS:

$$\frac{(5.9 \times 10.3 \times 1.7) - (6 \times 10 \times 1.5)}{5.9 \times 10.3 \times 1.7} \approx 0.129$$

PTS: 3

REF: 081235ia

STA: A.M.3

TOP: Error

KEY: volume and surface area

506 ANS:

$$78. \cos x = \frac{6}{28}$$

$$x \approx 78$$

PTS: 3

REF: 061235ia

STA: A.A.43

TOP: Using Trigonometry to Find an Angle

507 ANS:

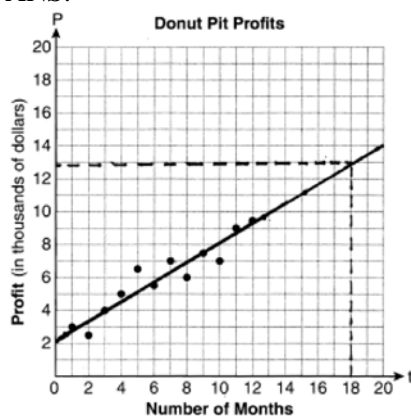

They will not reach their goal in 18 months.

PTS: 3

REF: 061036ia

STA: A.S.17

TOP: Scatter Plots

508 ANS:

$$6\sqrt{3} \frac{3\sqrt{75} + \sqrt{27}}{3} = \frac{3\sqrt{25}\sqrt{3} + \sqrt{9}\sqrt{3}}{3} = \frac{15\sqrt{3} + 3\sqrt{3}}{3} = \frac{18\sqrt{3}}{3} = 6\sqrt{3}$$

PTS: 3 REF: 061236ia STA: A.N.3 TOP: Operations with Radicals

509 ANS:

3, 0, 20. $15 - 12 = 3$. $12 - 12 = 0$

PTS: 3 REF: 081234ia STA: A.S.9 TOP: Analysis of Data

510 ANS:

12, 7. Both the median and the mode will increase.

PTS: 3 REF: 061134ia STA: A.S.16 TOP: Central Tendency

511 ANS:

$$-2, 3. \quad x^2 - x = 6$$

$$x^2 - x - 6 = 0$$

$$(x - 3)(x + 2) = 0$$

$$x = 3 \text{ or } -2$$

PTS: 3 REF: 011034ia STA: A.A.28 TOP: Roots of Quadratics

512 ANS:

56. If the circumference of circle O is 16π inches, the diameter, \overline{AD} , is 16 inches and the length of \overline{BC} is 12 inches $\frac{3}{4} \times 16$. The area of trapezoid $ABCD$ is $\frac{1}{2} \times 4(12 + 16) = 56$.

PTS: 3 REF: 060934ia STA: A.G.1 TOP: Compositions of Polygons and Circles
KEY: area

513 ANS:

$$(-2, 11). \quad x = \frac{-b}{2a} = \frac{-(-8)}{2(-2)} = -2$$

$$y = -2(-2)^2 - 8(-2) + 3 = 11$$

PTS: 3 REF: 080934ia STA: A.A.41
TOP: Identifying the Vertex of a Quadratic Given Equation

514 ANS:

$$2(x - 4) \geq \frac{1}{2}(5 - 3x)$$

$$4(x - 4) \geq 5 - 3x$$

$$4x - 16 \geq 5 - 3x$$

$$7x \geq 21$$

$$x \geq 3$$

PTS: 3 REF: 011234ia STA: A.A.24 TOP: Solving Inequalities

515 ANS:

$$4, -5. \quad \frac{x+2}{6} = \frac{3}{x-1}$$

$$(x+2)(x-1) = 18$$

$$x^2 - x + 2x - 2 = 18$$

$$x^2 + x - 20 = 0$$

$$(x+5)(x-4) = 0$$

$$x = -5 \text{ or } 4$$

PTS: 3

REF: 011136ia

STA: A.A.26

TOP: Solving Rationals

516 ANS:

$$\frac{3}{4x-8} \cdot \frac{3x+6}{4x+12} \div \frac{x^2-4}{x+3} = \frac{3(x+2)}{4(x+3)} \cdot \frac{x+3}{(x+2)(x-2)} = \frac{3}{4(x-2)}$$

PTS: 3

REF: 010935ia

STA: A.A.18

TOP: Multiplication and Division of Rationals

KEY: division

517 ANS:

$$-15, 2 \quad x^2 + 13x - 30 = 0$$

$$(x+15)(x-2) = 0$$

$$x = -15, 2$$

PTS: 3

REF: 081036ia

STA: A.A.28

TOP: Roots of Quadratics

518 ANS:

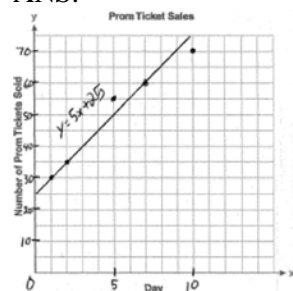

PTS: 3

REF: 060936ia

STA: A.S.8

TOP: Scatter Plots

519 ANS:

$\frac{38}{\pi}, 2.$ $V = \pi r^2 h$. $\frac{36}{\left(\frac{38}{\pi}\right)} \approx 2.97$. Three cans will not fit. The maximum number is 2.

$$342 = \pi \left(\frac{6}{2}\right)^2 h$$

$$\frac{342}{9\pi} = h$$

$$\frac{38}{\pi} = h$$

PTS: 3 REF: 010936ia STA: A.G.2 TOP: Volume

520 ANS:

(S,S), (S,K), (**S,D**), (K,S), (K,K), (**K,D**), (**D,S**), (**D,K**), (D,D), $\frac{4}{9}$

PTS: 3 REF: fall0736ia STA: A.S.19 TOP: Sample Space

521 ANS:

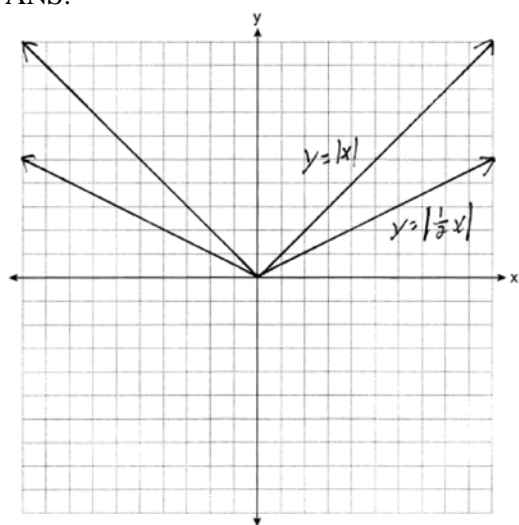

. Graph becomes wider as the coefficient approaches 0.

PTS: 3 REF: 061035ia STA: A.G.5 TOP: Graphing Absolute Value Functions

522 ANS:

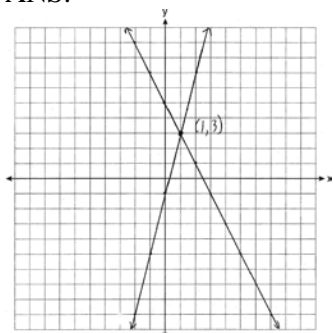

PTS: 3 REF: 011235ia STA: A.G.7 TOP: Solving Linear Systems

523 ANS:

30.4%; no, 23.3%. $\frac{7.50 - 5.75}{5.75} = 30.4\%$. $\frac{7.50 - 5.75}{7.50} = 23.3\%$

PTS: 3 REF: 080935ia STA: A.N.5 TOP: Percents

524 ANS:

0.102. $\frac{(5.3 \times 8.2 \times 4.1) - (5 \times 8 \times 4)}{5.3 \times 8.2 \times 4.1} = \frac{178.16 - 160}{178.16} = 0.102$

PTS: 3 REF: 011036ia STA: A.M.3 TOP: Error
KEY: volume and surface area

525 ANS:

Interval	Tally	Frequency
51-60		2
61-70		2
71-80		4
81-90		6
91-100		4

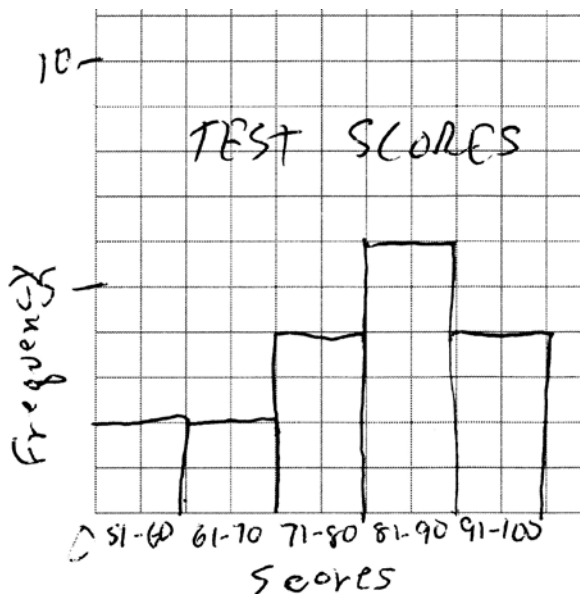

PTS: 3 REF: 011135ia STA: A.S.5
TOP: Frequency Histograms, Bar Graphs and Tables KEY: frequency histograms

526 ANS:

The turtle won by .5 minutes. Turtle: $\frac{d}{s} = \frac{100}{20} = 5$. Rabbit: $\frac{d}{s} = \frac{100}{40} = 2.5 + 3 = 5.5$

PTS: 3 REF: 011236ia STA: A.M.1 TOP: Speed

527 ANS:

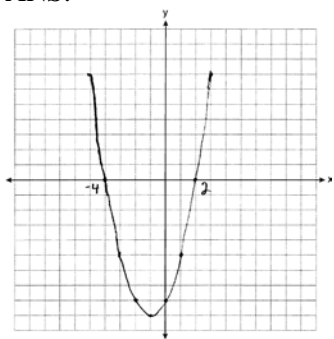

PTS: 3 REF: 061234ia STA: A.G.8 TOP: Solving Quadratics by Graphing

528 ANS:

81.3, 80, both increase

PTS: 3 REF: 011035ia STA: A.S.16 TOP: Central Tendency

529 ANS:

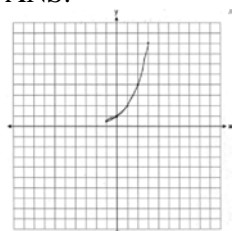
. The graph will never intersect the x -axis as $2^x > 0$ for all values of x .

PTS: 3 REF: 080835ia STA: A.G.4 TOP: Graphing Exponential Functions

530 ANS:

50, 1.5, 10. $\frac{\text{distance}}{\text{time}} = \frac{60}{1.2} = 50$. $\frac{\text{distance}}{\text{time}} = \frac{60}{40} = 1.5$. speed \times time = $55 \times 2 = 110$. $120 - 110 = 10$

PTS: 3 REF: fall0734ia STA: A.M.1 TOP: Speed

531 ANS:

$$-12. 3\left(\frac{2}{3}x + 3 < -2x - 7\right)$$

$$x + 9 < -6x - 21$$

$$7x < -30$$

$$x < \frac{-30}{7}$$

PTS: 3 REF: 061034ia STA: A.A.21 TOP: Interpreting Solutions

532 ANS:

$$y = \frac{3}{4}x + 10. \quad y = mx + b$$

$$4 = \frac{3}{4}(-8) + b$$

$$4 = -6 + b$$

$$10 = b$$

PTS: 3

REF: 011134ia

STA: A.A.34

TOP: Writing Linear Equations

533 ANS:

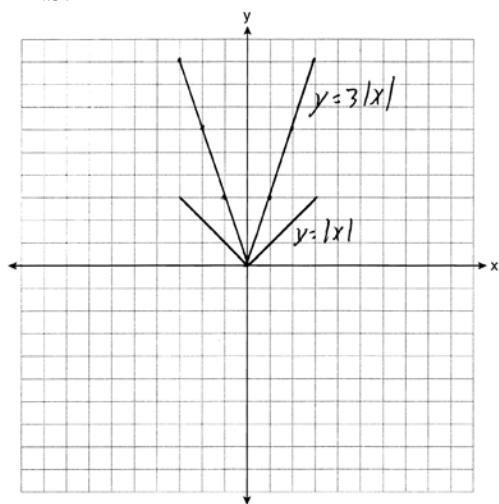

The graph becomes steeper.

PTS: 3

REF: 081134ia

STA: A.G.5

TOP: Graphing Absolute Value Functions

534 ANS:

$$10 + 2d \geq 75, 33. \quad 10 + 2d \geq 75$$

$$d \geq 32.5$$

PTS: 3

REF: 060834ia

STA: A.A.6

TOP: Modeling Inequalities

535 ANS:

minimum is 120, 1st quartile is 145, median is 292, 3rd quartile is 407, and maximum is 452

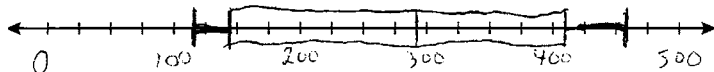

PTS: 3

REF: 081034ia

STA: A.S.5

TOP: Box-and-Whisker Plots

536 ANS:

$$(-3, -5), (3, 7). \quad x^2 + 2x - 8 = 2x + 1. \quad y = 2(3) + 1 = 7$$

$$x^2 - 9 = 0 \quad y = 2(-3) + 1 = -5$$

$$x = \pm 3$$

PTS: 3

REF: 081236ia

STA: A.A.11

TOP: Quadratic-Linear Systems

537 ANS:
 $0.65x + 35 \leq 45$
 $0.65x \leq 10$
 $x \leq 15$

PTS: 3 REF: 061135ia STA: A.A.6 TOP: Modeling Inequalities

538 ANS:
 80, 136 $V = lwh = 10 \cdot 2 \cdot 4 = 80$ $SA = 2lw + 2hw + 2lh = 2 \cdot 10 \cdot 2 + 2 \cdot 4 \cdot 2 + 2 \cdot 10 \cdot 4 = 136$

PTS: 3 REF: 081035ia STA: A.G.2 TOP: Surface Area

539 ANS:
 $y = \frac{2}{5}x + 2$. $m = \frac{4-0}{5-(-5)} = \frac{2}{5}$. $y = mx + b$.
 $4 = \frac{2}{5}(5) + b$
 $b = 2$

PTS: 3 REF: 080836ia STA: A.A.35 TOP: Writing Linear Equations

540 ANS:
 $60 - 42\sqrt{5}$. $3\sqrt{20}(2\sqrt{5} - 7) = 6\sqrt{100} - 21\sqrt{20} = 60 - 21\sqrt{4}\sqrt{5} = 60 - 42\sqrt{5}$

PTS: 3 REF: 080834ia STA: A.N.3 TOP: Operations with Radicals
 KEY: multiplication

**Integrated Algebra 4 Point Regents Exam Questions
Answer Section**

541 ANS:

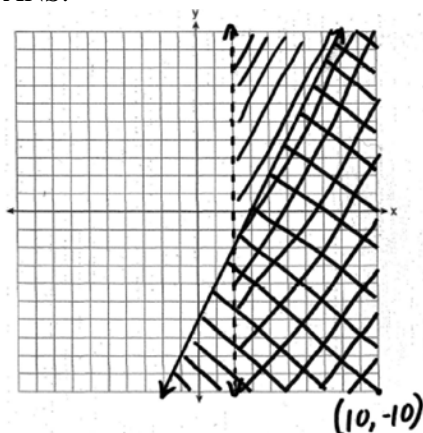

PTS: 4

REF: 010938ia

STA: A.G.7

TOP: Systems of Linear Inequalities

542 ANS:

618.45, 613.44, 0.008. $21.7 \times 28.5 = 618.45$. $21.6 \times 28.4 = 613.44$. $\left| \frac{618.45 - 613.44}{613.44} \right| \approx 0.008$. An error of less than 1% would seem to be insignificant.

PTS: 4

REF: 060838ia

STA: A.M.3

TOP: Error

KEY: area

543 ANS:

$$\frac{m}{5} + \frac{3(m-1)}{2} = 2(m-3)$$

$$\frac{2m}{10} + \frac{15(m-1)}{10} = 2m - 6$$

$$\frac{17m - 15}{10} = 2m - 6$$

$$17m - 15 = 20m - 60$$

$$45 = 3m$$

$$15 = m$$

PTS: 4

REF: 081139ia

STA: A.A.25

TOP: Solving Equations with Fractional Expressions

544 ANS:

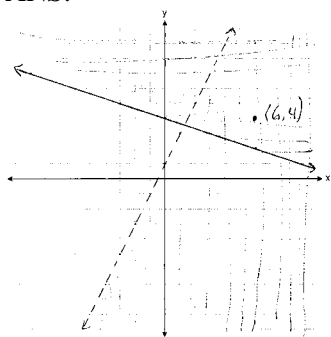

PTS: 4 REF: 081037ia STA: A.G.7 TOP: Systems of Linear Inequalities

545 ANS:

$$0.029 \cdot \frac{[2\pi(5.1)^2 + 2\pi(5.1)(15.1)] - [2\pi(5)^2 + 2\pi(5)(15)]}{2\pi(5.1)^2 + 2\pi(5.1)(15.1)} \approx \frac{647.294 - 628.319}{647.294} \approx 0.029$$

PTS: 4 REF: 011137ia STA: A.M.3 TOP: Error

KEY: volume and surface area

546 ANS:

$$39, 63. \tan 52 = \frac{50}{x}, \sin 52 = \frac{50}{x}$$

$$x \approx 39 \quad x \approx 63$$

PTS: 4 REF: 060937ia STA: A.A.44 TOP: Using Trigonometry to Find a Side

547 ANS:

315,000, 180,000, the median better represents value since it is closer to more prices than the mean.

PTS: 4 REF: 060839ia STA: A.S.4

TOP: Frequency Histograms, Bar Graphs and Tables

548 ANS:

30, 20, 71-80, 81-90 and 91-100

PTS: 4 REF: 061038ia STA: A.S.9

TOP: Frequency Histograms, Bar Graphs and Tables

549 ANS:

$$4. 3(x + 1) - 5x = 12 - (6x - 7)$$

$$3x + 3 - 5x = 12 - 6x + 7$$

$$-2x + 3 = -6x + 19$$

$$4x = 16$$

$$x = 4$$

PTS: 4 REF: 061238ia STA: A.A.22 TOP: Solving Equations

550 ANS:

$$\frac{4}{12} \times \frac{2}{11} \times \frac{1}{10} = \frac{8}{1320} \quad \frac{6}{12} \times \frac{5}{11} \times \frac{4}{10} + \frac{4}{12} \times \frac{3}{11} \times \frac{2}{10} = \frac{120}{1320} + \frac{24}{1320} = \frac{144}{1320}$$

PTS: 4

REF: 081137ia

STA: A.S.23

TOP: Theoretical Probability

KEY: dependent events

551 ANS:

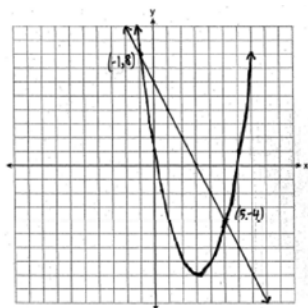

PTS: 4

REF: 060939ia

STA: A.G.9

TOP: Quadratic-Linear Systems

552 ANS:

6, 8, 10. Three consecutive even integers are x , $x + 2$ and $x + 4$. $(x + 2)(x + 4) = 10x + 20$

$$x^2 + 6x + 8 = 10x + 20$$

$$x^2 - 4x - 12 = 0$$

$$(x - 6)(x + 2) = 0$$

$$x = 6$$

PTS: 4

REF: 011039ia

STA: A.A.8

TOP: Writing Quadratics

553 ANS:

$$-\frac{9}{4} \cdot \frac{3}{4} = \frac{-(x+11)}{4x} + \frac{1}{2x}$$

$$\frac{3}{4} = \frac{-x-11}{4x} + \frac{2}{4x}$$

$$\frac{3}{4} = \frac{-x-9}{4x}$$

$$12x = -4x - 36$$

$$16x = -36$$

$$x = -\frac{9}{4}$$

PTS: 4

REF: 061137ia

STA: A.A.26

TOP: Solving Rationals

554 ANS:

$$m = 50¢, p = 15¢. \quad 3m + 2p = 1.80. \quad 9m + 6p = 5.40. \quad 4(.50) + 6p = 2.90$$

$$4m + 6p = 2.90 \quad 4m + 6p = 2.90 \quad 6p = .90$$

$$5m = 2.50 \quad p = \$0.15$$

$$m = \$0.50$$

PTS: 4

REF: 080837ia

STA: A.A.7

TOP: Writing Linear Systems

555 ANS:

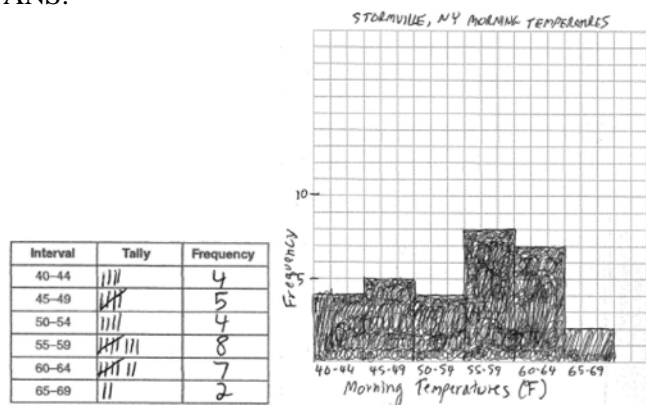

PTS: 4

REF: 060938ia

STA: A.S.5

TOP: Frequency Histograms, Bar Graphs and Tables

KEY: frequency histograms

556 ANS:

$$\frac{x^2 + 9x + 14}{x^2 - 49} \div \frac{3x + 6}{x^2 + x - 56} = \frac{(x+7)(x+2)}{(x+7)(x-7)} \cdot \frac{(x+8)(x-7)}{3(x+2)} = \frac{x+8}{3}$$

PTS: 4

REF: 061037ia

STA: A.A.18

TOP: Multiplication and Division of Rationals

KEY: division

557 ANS:

(W,H,A), (W,H,S), (W,T,A), (W,T,S), (W,B,A), (W,B,S), (R,H,A), (R,H,S), (R,T,A), (R,T,S), (R,B,A), (R,B,S).

8, 3

PTS: 4

REF: 011238ia

STA: A.S.19

TOP: Sample Space

558 ANS:

Hat A, add 1 not green to Hat A, add 11 green to Hat B, and add none to Hat C.

PTS: 4

REF: 081038ia

STA: A.S.22

TOP: Theoretical Probability

559 ANS:

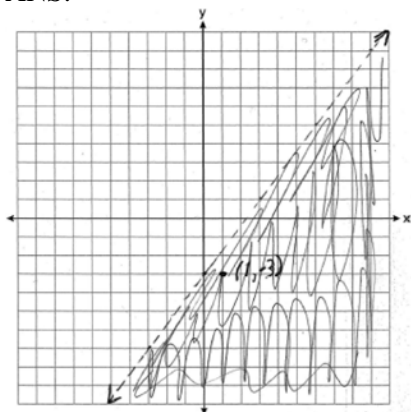

$(1, -3)$ is in the solution set. $4(1) - 3(-3) > 9$

$$4 + 9 > 9$$

PTS: 4 REF: 011038ia STA: A.G.6 TOP: Linear Inequalities

560 ANS:

(H,F,M), (H,F,J), (H,F,S), (H,A,M), (H,A,J), (H,A,S), (C,F,M), (C,F,J), (C,F,S), (C,A,M), (C,A,J), (C,A,S), (T,F,M), (T,F,J), (T,F,S), (T,A,M), (T,A,J), (T,A,S). There are 18 different kids' meals, 12 do not include juice and 6 include chicken nuggets.

PTS: 4 REF: 010939ia STA: A.S.19 TOP: Sample Space

561 ANS:

$$7, 9, 11. \quad x + (x + 2) + (x + 4) = 5(x + 2) - 18$$

$$3x + 6 = 5x - 8$$

$$14 = 2x$$

$$7 = x$$

PTS: 4 REF: 011237ia STA: A.A.6 TOP: Modeling Equations

562 ANS:

$$w(w + 15) = 54, 3, 18. \quad w(w + 15) = 54$$

$$w^2 + 15w - 54 = 0$$

$$(w + 18)(w - 3) = 0$$

$$w = 3$$

PTS: 4 REF: 060837ia STA: A.A.8 TOP: Geometric Applications of Quadratics

563 ANS:

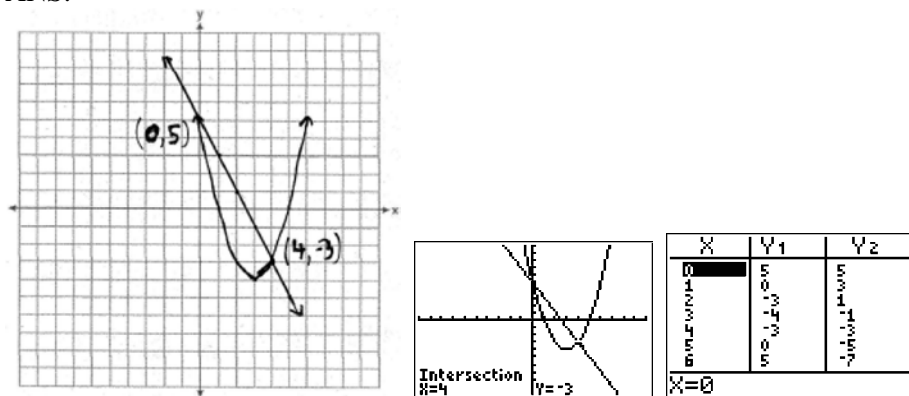

PTS: 4 REF: fall0738ia STA: A.G.9 TOP: Quadratic-Linear Systems

564 ANS:

(T,J,F), (T,J,N), (T,K,F), (T,K,N), (T,C,F), (T,C,N), (B,J,F), (B,J,N), (B,K,F), (B,K,N), (B,C,F), (B,C,N), (S,J,F), (S,J,N), (S,K,F), (S,K,N), (S,C,F), (S,C,N). 3, 12.

PTS: 4 REF: 061138ia STA: A.S.19 TOP: Sample Space

565 ANS:

$$(-2, 5). \quad 3x + 2y = 4 \quad 12x + 8y = 16. \quad 3x + 2y = 4$$

$$4x + 3y = 7 \quad 12x + 9y = 21 \quad 3x + 2(5) = 4$$

$$y = 5 \quad 3x = -6$$

$$x = -2$$

PTS: 4 REF: 010937ia STA: A.A.10 TOP: Solving Linear Systems

566 ANS:

$$54, 23. \quad \cos A = \frac{17}{29}. \quad \sqrt{29^2 - 17^2} \approx 23$$

$$x \approx 54$$

PTS: 4 REF: 081238ia STA: A.A.43 TOP: Using Trigonometry to Find an Angle

567 ANS:

$$6, -2. \quad \frac{x+1}{x} = \frac{-7}{x-12}$$

$$(x+1)(x-12) = -7x$$

$$x^2 - 11x - 12 = -7x$$

$$x^2 - 4x - 12 = 0$$

$$(x-6)(x+2) = 0$$

$$x = 6 \text{ or } -2$$

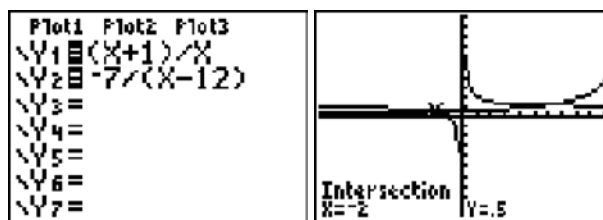

PTS: 4

REF: fall0739ia

STA: A.A.26

TOP: Solving Rationals

568 ANS:

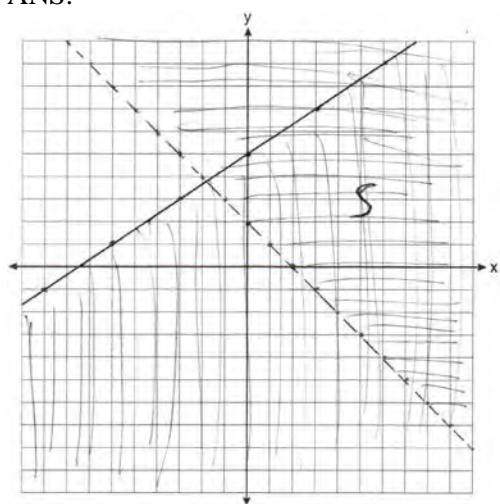

PTS: 4

REF: 011139ia

STA: A.G.7

TOP: Systems of Linear Inequalities

569 ANS:

(C,B,T), (C,B,5), (C,N,T), (C,N,5), (C,2,T), (C,2,5), (F,B,T), (F,B,5), (F,N,T), (F,N,5), (F,2,T), (F,2,5). 1, 2.

PTS: 4

REF: 081237ia

STA: A.S.19

TOP: Sample Space

570 ANS:

$$\frac{x-7}{3x} \cdot \frac{2x^2-8x-42}{6x^2} \div \frac{x^2-9}{x^2-3x} = \frac{2(x^2-4x-21)}{6x^2} \cdot \frac{x(x-3)}{(x+3)(x-3)} = \frac{(x-7)(x+3)}{3x} \cdot \frac{1}{x+3} = \frac{x-7}{3x}$$

PTS: 4

REF: 080937ia

STA: A.A.18

TOP: Multiplication and Division of Rationals

KEY: division

571 ANS:

$$84, 71 \quad \sin 50 = \frac{x}{110} \quad \cos 50 = \frac{y}{110}$$

$$x \approx 84 \quad y \approx 71$$

PTS: 4 REF: 081039ia STA: A.A.44 TOP: Using Trigonometry to Find a Side

572 ANS:

$26 \times 25 \times 24 \times 23 = 358,800$. $10^6 = 1,000,000$. Use the numeric password since there are over 500,000 employees

PTS: 4 REF: 061239ia STA: A.N.8 TOP: Permutations

573 ANS:

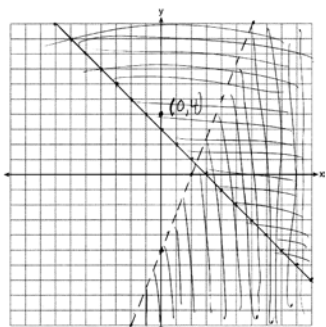

PTS: 4 REF: 081239ia STA: A.G.7 TOP: Systems of Linear Inequalities

574 ANS:

Number of Days Outside			Number of Days Outside	
Interval	Tally	Frequency	Interval	Cumulative Frequency
0-1		3	0-1	3
2-3		7	0-3	10
4-5		7	0-5	17
6-7		3	0-7	20

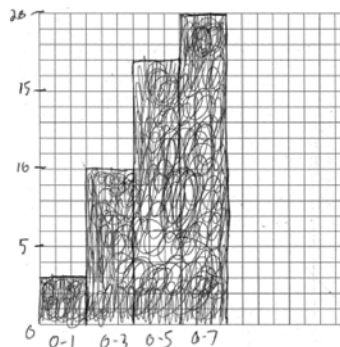

PTS: 4 REF: 080838ia STA: A.S.5
TOP: Frequency Histograms, Bar Graphs and Tables

KEY: cumulative frequency histograms

575 ANS:

$$259.99 \times 1.07 - 259.99(1 - 0.3) \times 1.07 = 83.46$$

PTS: 4 REF: 011239ia STA: A.N.5 TOP: Percents

576 ANS:

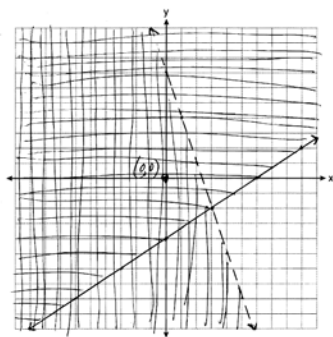

PTS: 4 REF: 061139ia STA: A.G.7 TOP: Systems of Linear Inequalities

577 ANS:

Carol's, by 14.9. $V_M = 5 \times 3.5 \times 7 = 122.5$. $V_C = \pi \times 2.5^2 \times 7 \approx 137.4$. $137.4 - 122.5 = 14.9$

PTS: 4 REF: 061237ia STA: A.G.2 TOP: Volume

578 ANS:

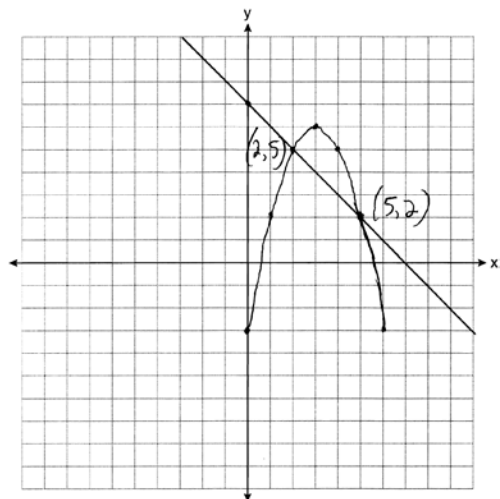

PTS: 4 REF: 081138ia STA: A.G.9 TOP: Quadratic-Linear Systems

579 ANS:

24,435.19. $30000(.95)^4 \approx 24435.19$

PTS: 4 REF: 011138ia STA: A.A.9 TOP: Exponential Functions

580 ANS:

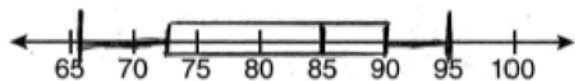

PTS: 4 REF: 080939ia STA: A.S.5 TOP: Box-and-Whisker Plots

581 ANS:

15,600,000, 4,368,000. $10 \times 10 \times 10 \times 26 \times 25 \times 24 = 15,600,000$. $10 \times 9 \times 8 \times 26 \times 25 \times 24 = 11,232,000$.
 $15,600,000 - 11,232,000 = 4,368,000$.

PTS: 4

REF: 011037ia

STA: A.N.8

TOP: Permutations

582 ANS:

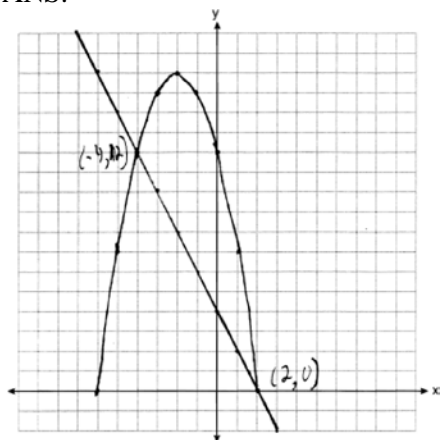

PTS: 4

REF: 061039ia

STA: A.G.9

TOP: Quadratic-Linear Systems

583 ANS:

225000, 175000, the median better represents the value since it is closer to more values than the mean.

PTS: 4

REF: fall0737ia

STA: A.S.4

TOP: Frequency Histograms, Bar Graphs and Tables

584 ANS:

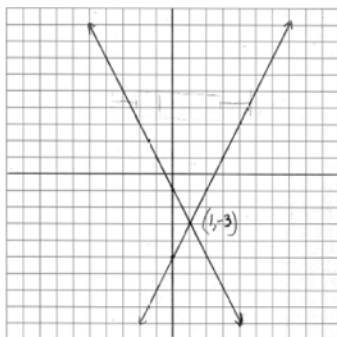

PTS: 4

REF: 080938ia

STA: A.G.7

TOP: Solving Linear Systems

585 ANS:

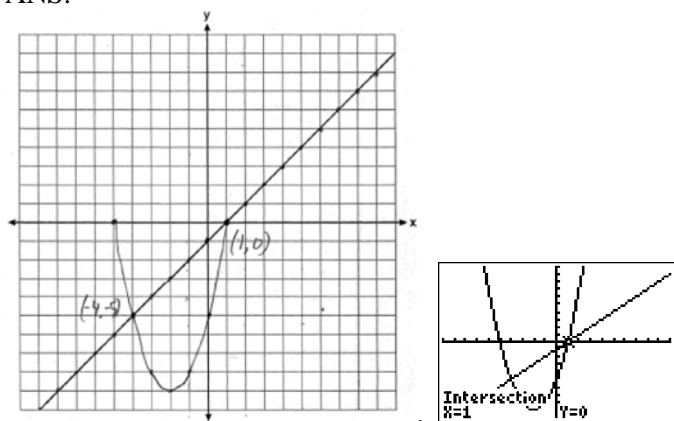

PTS: 4

REF: 080839ia

STA: A.G.9

TOP: Quadratic-Linear Systems