

JEFFERSON MATH PROJECT REGENTS BY PERFORMANCE INDICATOR: TOPIC

NY Integrated Algebra Regents Exam Questions
from Fall 2007 to January 2012 Sorted by PI: Topic

www.jmap.org

Dear Sir

I have to acknowledge the receipt of your favor of May 14. in which you mention that you have finished the 6. first books of Euclid, plane trigonometry, surveying & algebra and ask whether I think a further pursuit of that branch of science would be useful to you. there are some propositions in the latter books of Euclid, & some of Archimedes, which are useful, & I have no doubt you have been made acquainted with them. trigonometry, so far as this, is most valuable to every man, there is scarcely a day in which he will not resort to it for some of the purposes of common life. the science of calculation also is indispensable as far as the extraction of the square & cube roots; Algebra as far as the quadratic equation & the use of logarithms are often of value in ordinary cases: but all beyond these is but a luxury; a delicious luxury indeed; but not to be indulged in by one who is to have a profession to follow for his subsistence. in this light I view the conic sections, curves of the higher orders, perhaps even spherical trigonometry, Algebraical operations beyond the 2d dimension, and fluxions.

Letter from Thomas Jefferson to William G. Munford, Monticello, June 18, 1799.

TABLE OF CONTENTS

<u>TOPIC</u>	<u>PI: SUBTOPIC</u>	<u>QUESTION NUMBER</u>
NUMBERS, OPERATIONS AND PROPERTIES	A.N.6: Evaluating Expressions	1-4
	A.N.1: Identifying Properties	5-7
	A.N.1: Properties of Reals	8-11
	A.A.29-31: Set Theory	12-33
GRAPHS AND STATISTICS	A.S.5, 9: Frequency Histograms, Bar Graphs and Tables	34-39
	A.S.5, 6: Box-and-Whisker Plots	40-49
	A.S.11: Quartiles and Percentiles	50
	A.S.7-8, 12, 17: Scatter Plots	51-62
	A.S.4, 16: Central Tendency	63-69
	A.S.16: Average Known with Missing Data	70
	A.S.1-3, 13-14: Analysis of Data	71-89
A.M.3: Error	90-102	
PROBABILITY	A.S.19: Sample Space	103-107
	A.S.21: Experimental Probability	108-111
	A.S.20, 22, 23: Theoretical Probability	112-121
	A.S.20, 22, 23: Geometric Probability	122-127
	A.S.18: Conditional Probability	128
	A.N.7: Multiplication Counting Principle	129-130
	A.N.8: Permutations	131-137
EXPRESSIONS AND EQUATIONS	A.A.1-3: Expressions	138-152
	A.A.22: Solving Equations	153-156
	A.A.25: Solving Equations with Fractional Expressions	157-162
	A.A.4-6: Modeling Equations	163-168
	A.A.22: Transforming Formulas	169-176
RATE	A.M.1: Using Rate	177-179
	A.M.1: Speed	180-187
	A.M.2: Conversions	188-192
	A.N.5: Percents	193-196
	A.N.5: Direct Variation	197-198
LINEAR EQUATIONS	A.A.32-33, 37: Slope	199-210
	A.G.4: Graphing Linear Functions	211
	A.A.34-35: Writing Linear Equations	212-220
	A.A.39: Identifying Points on a Line	221-224
	A.A.36, 38: Parallel and Perpendicular Lines	225-232
INEQUALITIES	A.A.24: Solving Inequalities	233-235
	A.A.21: Interpreting Solutions	236-240
	A.A.4-6: Modeling Inequalities	241-251
	A.G.6: Linear Inequalities	252-256
ABSOLUTE VALUE	A.G.4-5: Graphing Absolute Value Functions	257-262

QUADRATICS	A.A.20: Factoring Polynomials	263-265
	A.A.19: Factoring the Difference of Perfect Squares	266-276
	A.A.27: Solving Quadratics by Factoring	277
	A.A.28: Roots of Quadratics	278-284
	A.G.5: Graphing Quadratic Functions	285-287
	A.G.8: Solving Quadratics by Graphing	288-291
	A.A.8: Writing Quadratics	292-294
	A.A.8: Geometric Applications of Quadratics	295-297
	A.G.10: Identifying the Vertex of a Quadratic Given Graph	298-304
	A.A.41: Identifying the Vertex of a Quadratic Given Equation	305-309
SYSTEMS	A.A.10, G.7: Solving Linear Systems	310-318
	A.A.7: Writing Linear Systems	319-328
	A.A.40, G.7: Systems of Linear Inequalities	329-336
	A.A.11, G.9: Quadratic-Linear Systems	337-349
POWERS	A.A.13: Addition and Subtraction of Monomials	350
	A.A.13: Addition and Subtraction of Polynomials	351-356
	A.A.13: Multiplication of Polynomials	357
	A.A.14: Division of Polynomials	358-359
	A.A.12: Multiplication of Powers	360-361
	A.A.12: Division of Powers	362-367
	A.A.12: Powers of Powers	368-370
	A.N.4: Operations with Scientific Notation	371-375
	A.A.9: Exponential Functions	376-386
A.G.4: Graphing Exponential Functions	387	
RADICALS	A.N.2: Simplifying Radicals	388-395
	A.N.3: Operations with Radicals	396-400
RATIONALS	A.A.16: Rational Expressions	401-407
	A.A.15: Undefined Rationals	408-415
	A.A.18: Multiplication and Division of Rationals	416-421
	A.A.18: Addition and Subtraction of Rationals	422-431
	A.A.26: Solving Rationals	432-439
FUNCTIONS	A.G.4: Families of Functions	440-445
	A.G.4: Identifying the Equation of a Graph	446
	A.G.8: Defining Functions	447-455
TRIANGLES	A.A.45: Pythagorean Theorem	456-464
TRIGONOMETRY	A.A.42: Trigonometric Ratios	465-472
	A.A.44: Using Trigonometry to Find a Side	473-479
	A.A.44: Using Trigonometry to Find an Angle	480-486
MEASURING IN THE PLANE AND SPACE	A.G.1: Compositions of Polygons and Circles	487-497
	A.G.2: Volume	498-502
	A.G.2: Surface Area	503-507

Integrated Algebra Regents Exam Questions by Performance Indicator: Topic

**NUMBERS, OPERATIONS
AND PROPERTIES**

A.N.6: EVALUATING EXPRESSIONS

- 1 What is the value of the expression $|-5x + 12|$ when $x = 5$?
 - 1 -37
 - 2 -13
 - 3 13
 - 4 37

- 2 The value of the expression $-|a - b|$ when $a = 7$ and $b = -3$ is
 - 1 -10
 - 2 10
 - 3 -4
 - 4 4

- 3 What is the value of the expression $(a^3 + b^0)^2$ when $a = -2$ and $b = 4$?
 - 1 64
 - 2 49
 - 3 -49
 - 4 -64

- 4 What is the value of the expression $-3x^2y + 4x$ when $x = -4$ and $y = 2$?
 - 1 -112
 - 2 -80
 - 3 80
 - 4 272

A.N.1: IDENTIFYING PROPERTIES

- 5 Which property is illustrated by the equation $ax + ay = a(x + y)$?
 - 1 associative
 - 2 commutative
 - 3 distributive
 - 4 identity

- 6 The statement $2 + 0 = 2$ is an example of the use of which property of real numbers?
 - 1 associative
 - 2 additive identity
 - 3 additive inverse
 - 4 distributive

- 7 A method for solving $5(x - 2) - 2(x - 5) = 9$ is shown below. Identify the property used to obtain each of the two indicated steps.

$$5(x - 2) - 2(x - 5) = 9$$

(1) $5x - 10 - 2x + 10 = 9$	(1) _____
(2) $5x - 2x - 10 + 10 = 9$	(2) _____
$3x + 0 = 9$	
$3x = 9$	
$x = 3$	

A.N.1: PROPERTIES OF REALS

- 8 What is the additive inverse of the expression $a - b$?
 - 1 $a + b$
 - 2 $a - b$
 - 3 $-a + b$
 - 4 $-a - b$

- 9 Which equation illustrates the associative property?
 - 1 $x + y + z = x + y + z$
 - 2 $x(y + z) = xy + xz$
 - 3 $x + y + z = z + y + x$
 - 4 $(x + y) + z = x + (y + z)$

- 10 Which equation is an example of the use of the associative property of addition?
 - 1 $x + 7 = 7 + x$
 - 2 $3(x + y) = 3x + 3y$
 - 3 $(x + y) + 3 = x + (y + 3)$
 - 4 $3 + (x + y) = (x + y) + 3$

Integrated Algebra Regents Exam Questions by Performance Indicator: Topic

www.jmap.org

- 11 Perform the indicated operation: $-6(a - 7)$
State the name of the property used.

A.A.29: SET THEORY

- 12 The set $\{1, 2, 3, 4\}$ is equivalent to
 1 $\{x \mid 1 < x < 4, \text{ where } x \text{ is a whole number}\}$
 2 $\{x \mid 0 < x < 4, \text{ where } x \text{ is a whole number}\}$
 3 $\{x \mid 0 < x \leq 4, \text{ where } x \text{ is a whole number}\}$
 4 $\{x \mid 1 < x \leq 4, \text{ where } x \text{ is a whole number}\}$
- 13 The set $\{11, 12\}$ is equivalent to
 1 $\{x \mid 11 < x < 12, \text{ where } x \text{ is an integer}\}$
 2 $\{x \mid 11 < x \leq 12, \text{ where } x \text{ is an integer}\}$
 3 $\{x \mid 10 \leq x < 12, \text{ where } x \text{ is an integer}\}$
 4 $\{x \mid 10 < x \leq 12, \text{ where } x \text{ is an integer}\}$
- 14 Which set-builder notation describes $\{-3, -2, -1, 0, 1, 2\}$?
 1 $\{x \mid -3 \leq x < 2, \text{ where } x \text{ is an integer}\}$
 2 $\{x \mid -3 < x \leq 2, \text{ where } x \text{ is an integer}\}$
 3 $\{x \mid -3 < x < 2, \text{ where } x \text{ is an integer}\}$
 4 $\{x \mid -3 \leq x \leq 2, \text{ where } x \text{ is an integer}\}$
- 15 Which notation describes $\{1, 2, 3\}$?
 1 $\{x \mid 1 \leq x < 3, \text{ where } x \text{ is an integer}\}$
 2 $\{x \mid 0 < x \leq 3, \text{ where } x \text{ is an integer}\}$
 3 $\{x \mid 1 < x < 3, \text{ where } x \text{ is an integer}\}$
 4 $\{x \mid 0 \leq x \leq 3, \text{ where } x \text{ is an integer}\}$
- 16 Which set builder notation describes $\{-2, -1, 0, 1, 2, 3\}$?
 1 $\{x \mid -3 \leq x \leq 3, \text{ where } x \text{ is an integer}\}$
 2 $\{x \mid -3 < x \leq 4, \text{ where } x \text{ is an integer}\}$
 3 $\{x \mid -2 < x < 3, \text{ where } x \text{ is an integer}\}$
 4 $\{x \mid -2 \leq x < 4, \text{ where } x \text{ is an integer}\}$
- 17 Which interval notation represents the set of all numbers from 2 through 7, inclusive?
 1 $(2, 7)$
 2 $(2, 7]$
 3 $[2, 7)$
 4 $[2, 7]$

- 18 Which interval notation represents the set of all numbers greater than or equal to 5 and less than 12?

- 1 $[5, 12)$
 2 $(5, 12]$
 3 $(5, 12)$
 4 $[5, 12]$

- 19 Which interval notation represents the set of all real numbers greater than 2 and less than or equal to 20?

- 1 $(2, 20)$
 2 $(2, 20]$
 3 $[2, 20)$
 4 $[2, 20]$

- 20 In interval notation, the set of all real numbers greater than -6 and less than or equal to 14 is represented by

- 1 $(-6, 14)$
 2 $[-6, 14)$
 3 $(-6, 14]$
 4 $[-6, 14]$

A.A.30: SET THEORY

- 21 Consider the set of integers greater than -2 and less than 6 . A subset of this set is the positive factors of 5 . What is the complement of this subset?

- 1 $\{0, 2, 3, 4\}$
 2 $\{-1, 0, 2, 3, 4\}$
 3 $\{-2, -1, 0, 2, 3, 4, 6\}$
 4 $\{-2, -1, 0, 1, 2, 3, 4, 5, 6\}$

- 22 Given:

$A = \{\text{All even integers from } 2 \text{ to } 20, \text{ inclusive}\}$

$B = \{10, 12, 14, 16, 18\}$

What is the complement of set B within the universe of set A ?

- 1 $\{4, 6, 8\}$
 2 $\{2, 4, 6, 8\}$
 3 $\{4, 6, 8, 20\}$
 4 $\{2, 4, 6, 8, 20\}$

23 Given: Set $U = \{S, O, P, H, I, A\}$

Set $B = \{A, I, O\}$

If set B is a subset of set U , what is the complement of set B ?

- 1 $\{O, P, S\}$
- 2 $\{I, P, S\}$
- 3 $\{A, H, P\}$
- 4 $\{H, P, S\}$

24 Given: $U = \{1, 2, 3, 4, 5, 6, 7, 8\}$

$B = \{2, 3, 5, 6\}$

Set B is a subset of set U . What is the complement of set B ?

- 1 $\{ \}$
- 2 $\{2, 3, 5, 6\}$
- 3 $\{1, 4, 7, 8\}$
- 4 $\{1, 2, 3, 4, 5, 6, 7, 8\}$

25 If the universal set is {pennies, nickels, dimes, quarters}, what is the complement of the set {nickels}?

- 1 $\{ \}$
- 2 {pennies, quarters}
- 3 {pennies, dimes, quarters}
- 4 {pennies, nickels, dimes, quarters}

26 Twelve players make up a high school basketball team. The team jerseys are numbered 1 through 12. The players wearing the jerseys numbered 3, 6, 7, 8, and 11 are the only players who start a game. Using set notation, list the complement of this subset.

27 Which set represents the intersection of sets A , B , and C shown in the diagram below?

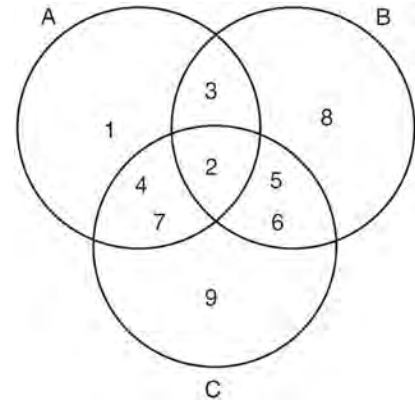

- 1 $\{3, 4, 5, 6, 7\}$
- 2 $\{2\}$
- 3 $\{2, 3, 4, 5, 6, 7\}$
- 4 $\{1, 2, 3, 4, 5, 6, 7, 8, 9\}$

28 Given: $Q = \{0, 2, 4, 6\}$

$W = \{0, 1, 2, 3\}$

$Z = \{1, 2, 3, 4\}$

What is the intersection of sets Q , W , and Z ?

- 1 $\{2\}$
- 2 $\{0, 2\}$
- 3 $\{1, 2, 3\}$
- 4 $\{0, 1, 2, 3, 4, 6\}$

29 Given: $X = \{1, 2, 3, 4\}$

$Y = \{2, 3, 4, 5\}$

$Z = \{3, 4, 5, 6\}$

What is the intersection of sets X , Y , and Z ?

- 1 $\{3, 4\}$
- 2 $\{2, 3, 4\}$
- 3 $\{3, 4, 5\}$
- 4 $\{1, 2, 3, 4, 5, 6\}$

30 Given:

$$\text{Set } A = \{(-2, -1), (-1, 0), (1, 8)\}$$

$$\text{Set } B = \{(-3, -4), (-2, -1), (-1, 2), (1, 8)\}$$

What is the intersection of sets A and B ?

- 1 $\{(1, 8)\}$
- 2 $\{(-2, -1)\}$
- 3 $\{(-2, -1), (1, 8)\}$
- 4 $\{(-3, -4), (-2, -1), (-1, 2), (-1, 0), (1, 8)\}$

31 Maureen tracks the range of outdoor temperatures over three days. She records the following information.

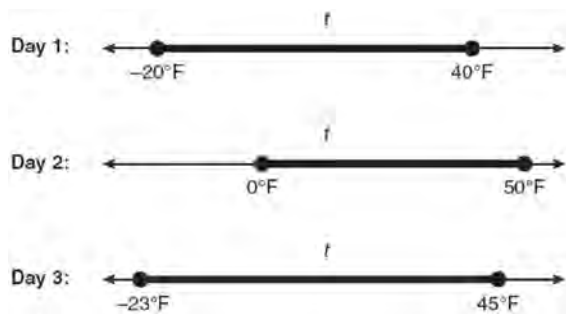

Express the intersection of the three sets as an inequality in terms of temperature, t .

32 Given: $A = \{3, 6, 9, 12, 15\}$

$$B = \{2, 4, 6, 8, 10, 12\}$$

What is the union of sets A and B ?

- 1 $\{6\}$
- 2 $\{6, 12\}$
- 3 $\{2, 3, 4, 8, 9, 10, 15\}$
- 4 $\{2, 3, 4, 6, 8, 9, 10, 12, 15\}$

33 Given: $A = \{2, 4, 5, 7, 8\}$

$$B = \{3, 5, 8, 9\}$$

What is $A \cup B$?

- 1 $\{5\}$
- 2 $\{5, 8\}$
- 3 $\{2, 3, 4, 7, 9\}$
- 4 $\{2, 3, 4, 5, 7, 8, 9\}$

GRAPHS AND STATISTICS

A.S.5: FREQUENCY HISTOGRAMS, BAR GRAPHS AND TABLES

34 Ms. Hopkins recorded her students' final exam scores in the frequency table below.

Interval	Tally	Frequency
61–70	###	5
71–80		4
81–90	###	9
91–100	###	6

On the grid below, construct a frequency histogram based on the table.

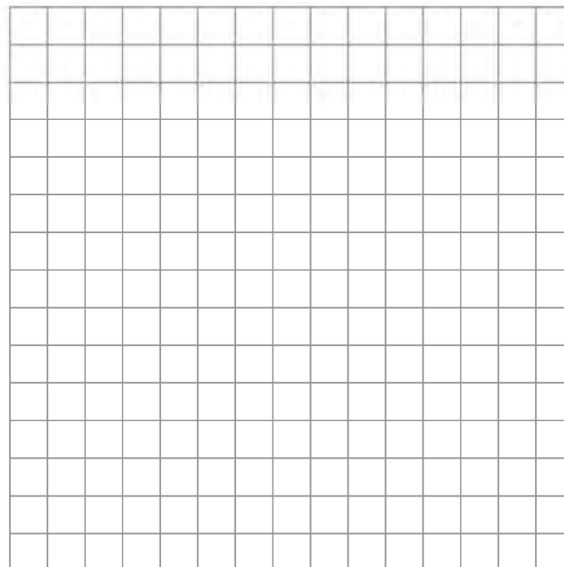

Integrated Algebra Regents Exam Questions by Performance Indicator: Topic

www.jmap.org

- 35 The Fahrenheit temperature readings on 30 April mornings in Stormville, New York, are shown below.

41°, 58°, 61°, 54°, 49°, 46°, 52°, 58°, 67°, 43°,
 47°, 60°, 52°, 58°, 48°, 44°, 59°, 66°, 62°, 55°,
 44°, 49°, 62°, 61°, 59°, 54°, 57°, 58°, 63°, 60°

Using the data, complete the frequency table below.

Interval	Tally	Frequency
40–44		
45–49		
50–54		
55–59		
60–64		
65–69		

On the grid below, construct and label a frequency histogram based on the table.

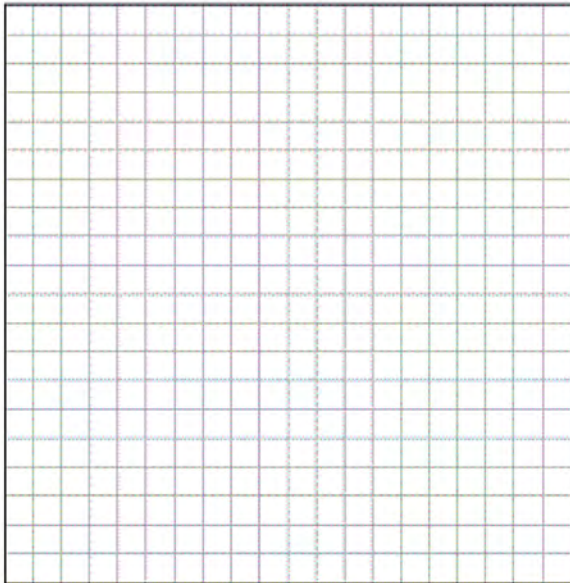

- 36 The test scores for 18 students in Ms. Mosher’s class are listed below:

86, 81, 79, 71, 58, 87, 52, 71, 87,
 87, 93, 64, 94, 81, 76, 98, 94, 68

Complete the frequency table below.

Interval	Tally	Frequency
51–60		
61–70		
71–80		
81–90		
91–100		

Draw and label a frequency histogram on the grid below.

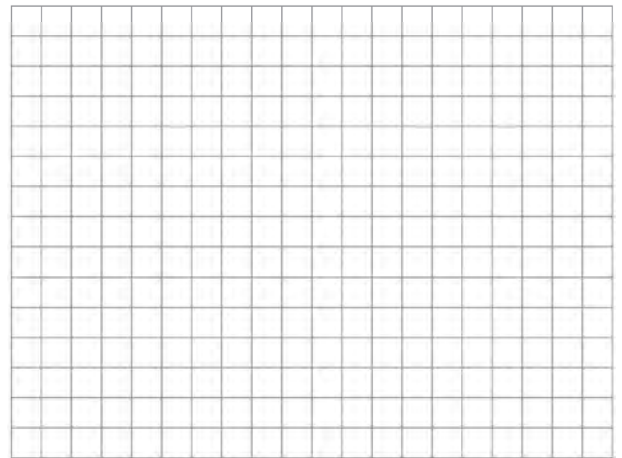

- 37 Twenty students were surveyed about the number of days they played outside in one week. The results of this survey are shown below.

{6,5,4,3,0,7,1,5,4,4,3,2,2,3,2,4,3,4,0,7}

Complete the frequency table below for these data.

Interval	Tally	Frequency
0–1		
2–3		
4–5		
6–7		

Complete the cumulative frequency table below using these data.

Number of Days Outside

Interval	Cumulative Frequency
0-1	
0-3	
0-5	
0-7	

On the grid below, create a cumulative frequency histogram based on the table you made.

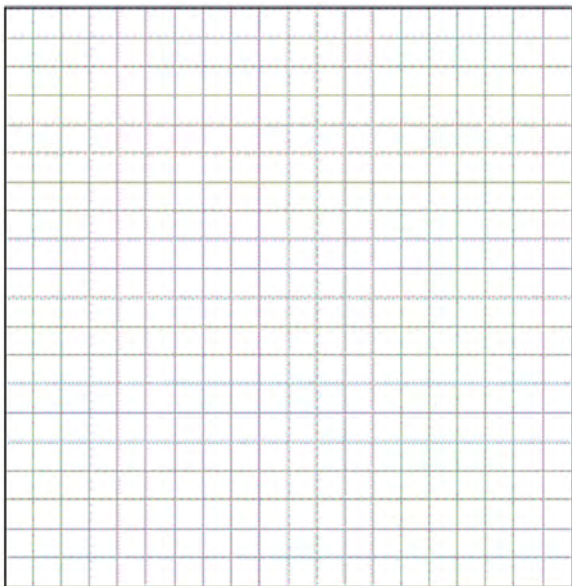

A.S.9: FREQUENCY HISTOGRAMS, BAR GRAPHS AND TABLES

38 The table below shows a cumulative frequency distribution of runners' ages.

Cumulative Frequency Distribution of Runners' Ages

Age Group	Total
20-29	8
20-39	18
20-49	25
20-59	31
20-69	35

According to the table, how many runners are in their forties?

- 1 25
- 2 10
- 3 7
- 4 6

39 The diagram below shows a cumulative frequency histogram of the students' test scores in Ms. Wedow's algebra class.

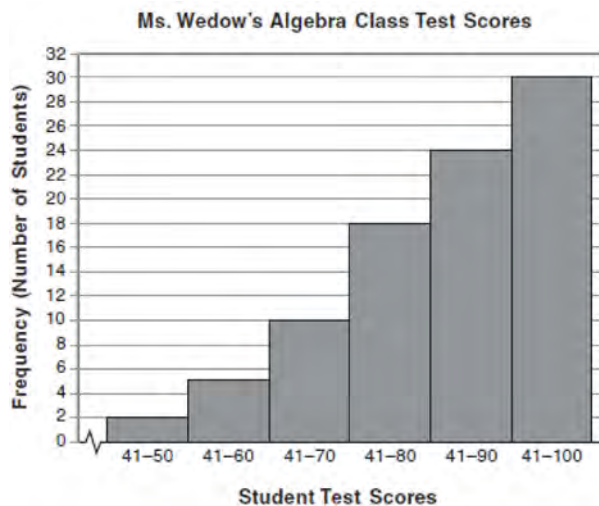

Determine the total number of students in the class. Determine how many students scored higher than 70. State which *ten-point interval* contains the median. State which *two ten-point intervals* contain the same frequency.

A.S.5: BOX-AND-WHISKER PLOTS

- 40 The data set 5, 6, 7, 8, 9, 9, 9, 10, 12, 14, 17, 17, 18, 19, 19 represents the number of hours spent on the Internet in a week by students in a mathematics class. Which box-and-whisker plot represents the data?

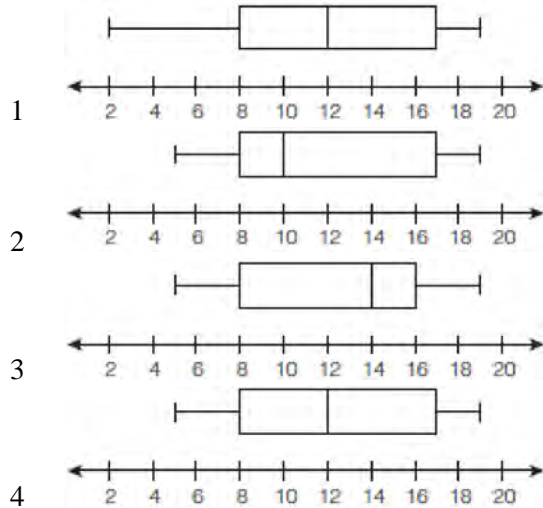

- 41 The test scores from Mrs. Gray's math class are shown below.
72, 73, 66, 71, 82, 85, 95, 85, 86, 89, 91, 92
Construct a box-and-whisker plot to display these data.

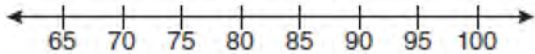

- 42 The number of songs fifteen students have on their MP3 players is:
120, 124, 132, 145, 200, 255, 260, 292,
308, 314, 342, 407, 421, 435, 452
State the values of the minimum, 1st quartile, median, 3rd quartile, and maximum. Using these values, construct a box-and-whisker plot using an appropriate scale on the line below.

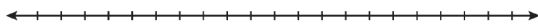

A.S.6: BOX-AND-WHISKER PLOTS

- 43 What is the value of the third quartile shown on the box-and-whisker plot below?

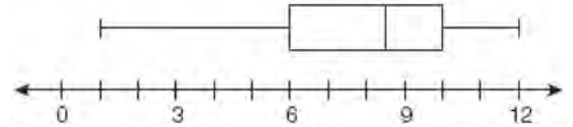

- 1 6
2 8.5
3 10
4 12
- 44 The box-and-whisker plot below represents students' scores on a recent English test.

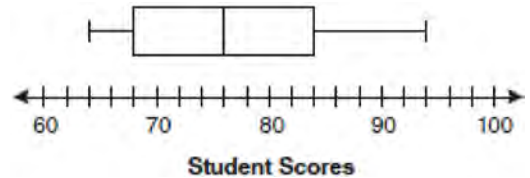

What is the value of the upper quartile?

- 1 68
2 76
3 84
4 94
- 45 The box-and-whisker plot below represents the math test scores of 20 students.

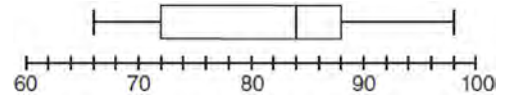

What percentage of the test scores are *less than* 72?

- 1 25
2 50
3 75
4 100

- 46 The box-and-whisker plot below represents the ages of 12 people.

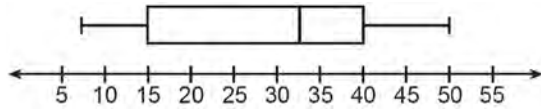

What percentage of these people are age 15 or older?

- 1 25
 - 2 35
 - 3 75
 - 4 85
- 47 What is the range of the data represented in the box-and-whisker plot shown below?

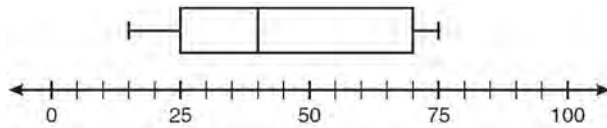

- 1 40
 - 2 45
 - 3 60
 - 4 100
- 48 Based on the box-and-whisker plot below, which statement is *false*?

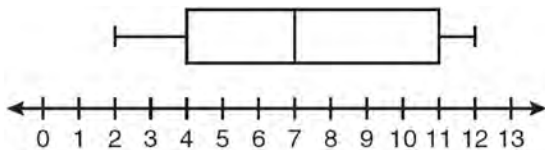

- 1 The median is 7.
- 2 The range is 12.
- 3 The first quartile is 4.
- 4 The third quartile is 11.

- 49 A movie theater recorded the number of tickets sold daily for a popular movie during the month of June. The box-and-whisker plot shown below represents the data for the number of tickets sold, in hundreds.

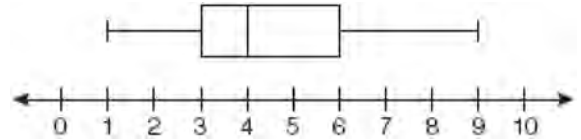

Which conclusion can be made using this plot?

- 1 The second quartile is 600.
- 2 The mean of the attendance is 400.
- 3 The range of the attendance is 300 to 600.
- 4 Twenty-five percent of the attendance is between 300 and 400.

A.S.11: QUARTILES AND PERCENTILES

- 50 The freshman class held a canned food drive for 12 weeks. The results are summarized in the table below.

Canned Food Drive Results

Week	1	2	3	4	5	6	7	8	9	10	11	12
Number of Cans	20	35	32	45	58	46	28	23	31	79	65	62

Which number represents the second quartile of the number of cans of food collected?

- 1 29.5
- 2 30.5
- 3 40
- 4 60

A.S.7: SCATTER PLOTS

- 51 For 10 days, Romero kept a record of the number of hours he spent listening to music. The information is shown in the table below.

Day	1	2	3	4	5	6	7	8	9	10
Hours	9	3	2	6	8	6	10	4	5	2

Which scatter plot shows Romero's data graphically?

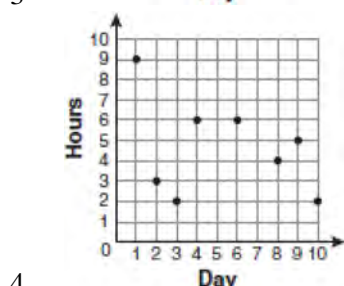
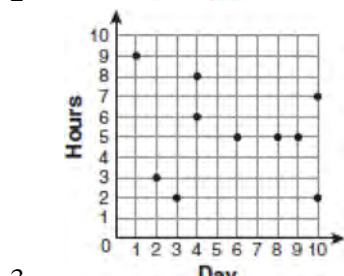
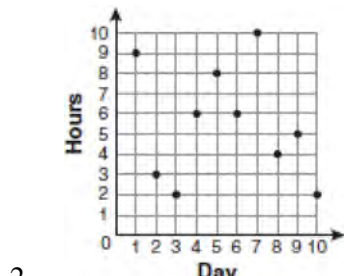
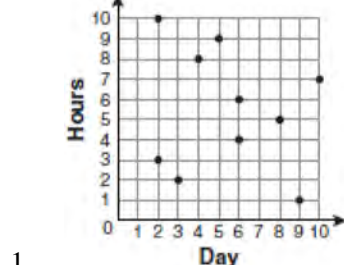

- 52 The school store did a study comparing the cost of a sweatshirt with the number of sweatshirts sold. The price was changed several times and the numbers of sweatshirts sold were recorded. The data are shown in the table below.

Cost of Sweatshirt	\$10	\$25	\$15	\$20	\$5
Number Sold	9	6	15	11	14

Which scatter plot represents the data?

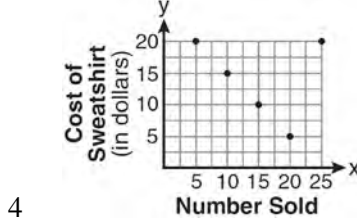
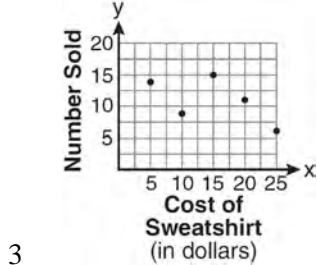
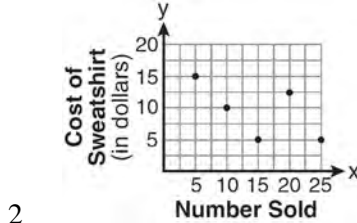
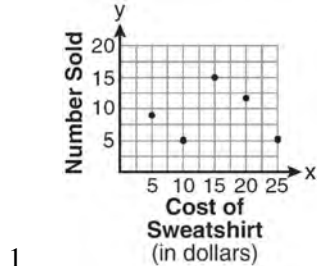

- 53 The maximum height and speed of various roller coasters in North America are shown in the table below.

Maximum Speed, in mph, (x)	45	50	54	60	65	70
Maximum Height, in feet, (y)	63	80	105	118	141	107

Which graph represents a correct scatter plot of the data?

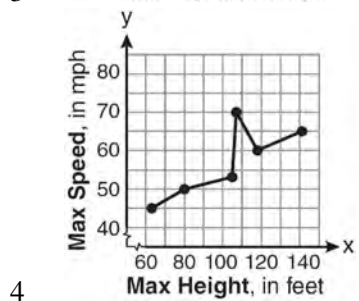
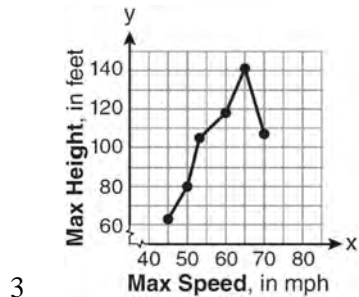
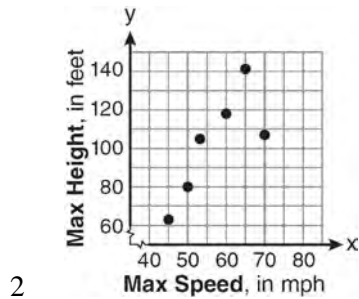
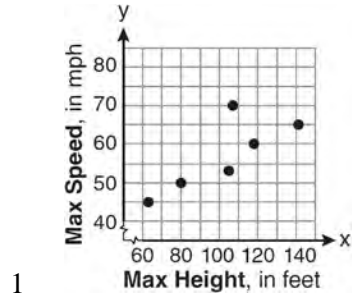

A.S.8: SCATTER PLOTS

- 54 A scatter plot was constructed on the graph below and a line of best fit was drawn.

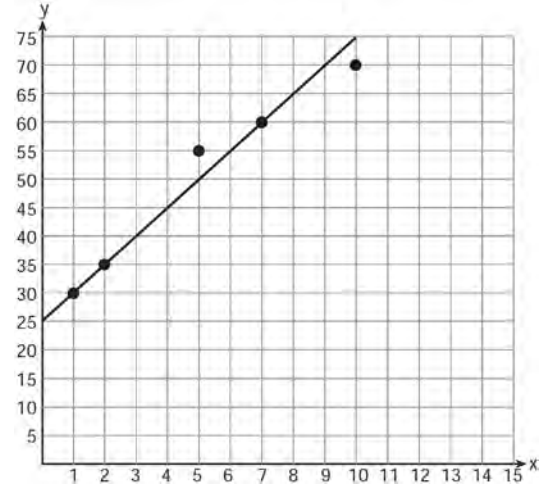

What is the equation of this line of best fit?

- 1 $y = x + 5$
- 2 $y = x + 25$
- 3 $y = 5x + 5$
- 4 $y = 5x + 25$

55 Which equation most closely represents the line of best fit for the scatter plot below?

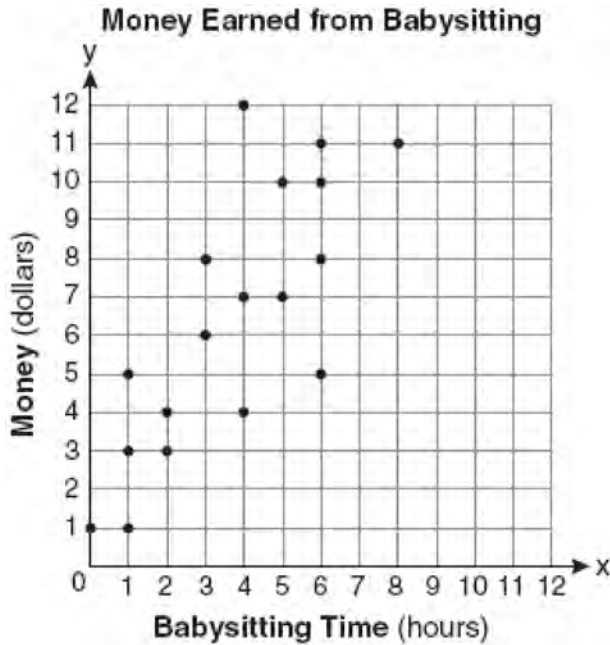

- 1 $y = x$
- 2 $y = \frac{2}{3}x + 1$
- 3 $y = \frac{3}{2}x + 4$
- 4 $y = \frac{3}{2}x + 1$

56 The table below shows the number of prom tickets sold over a ten-day period.

Prom Ticket Sales

Day (x)	1	2	5	7	10
Number of Prom Tickets Sold (y)	30	35	55	60	70

Plot these data points on the coordinate grid below. Use a consistent and appropriate scale. Draw a reasonable line of best fit and write its equation.

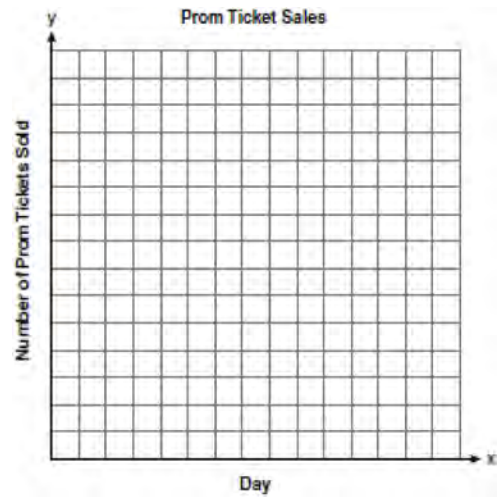

A.S.12: SCATTER PLOTS

57 There is a negative correlation between the number of hours a student watches television and his or her social studies test score. Which scatter plot below displays this correlation?

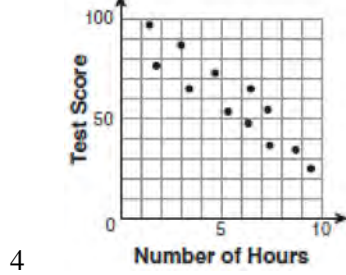
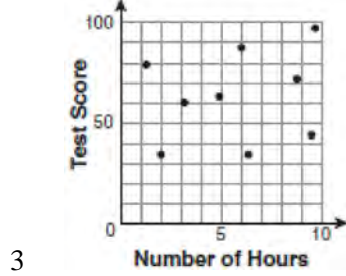
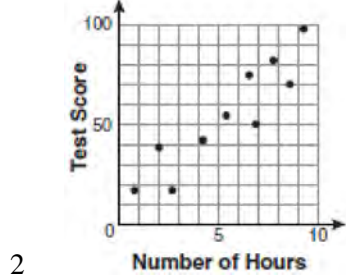
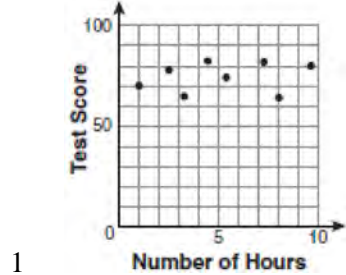

58 Which scatter plot shows the relationship between x and y if x represents a student score on a test and y represents the number of incorrect answers a student received on the same test?

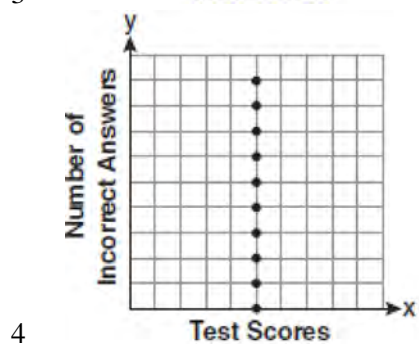
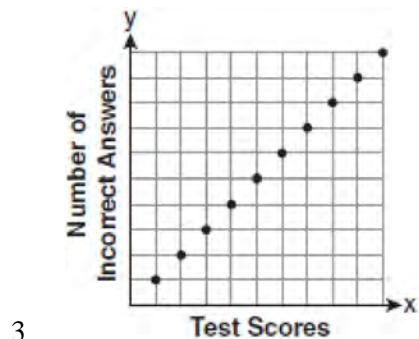
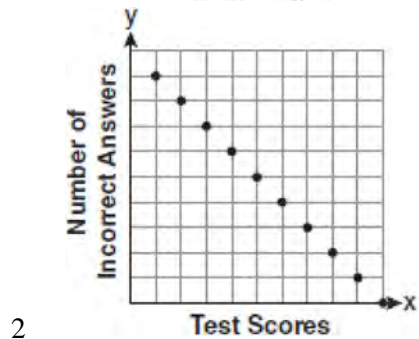
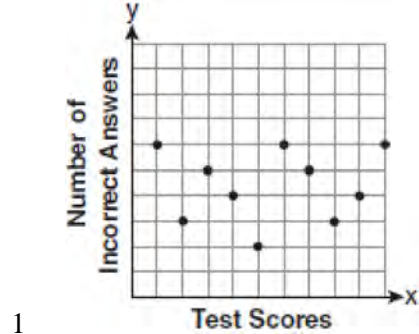

59 What is the relationship between the independent and dependent variables in the scatter plot shown below?

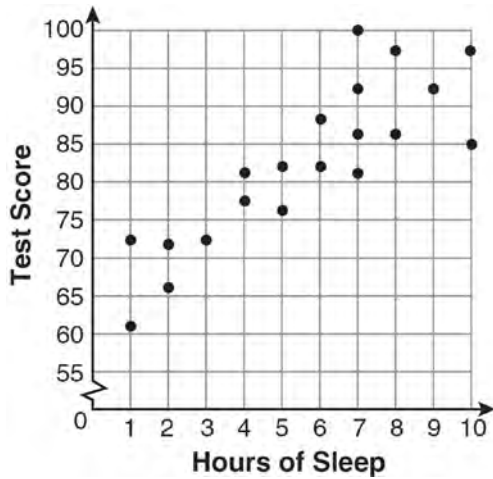

- 1 undefined correlation
- 2 negative correlation
- 3 positive correlation
- 4 no correlation

60 The scatter plot below represents the relationship between the number of peanuts a student eats and the student's bowling score.

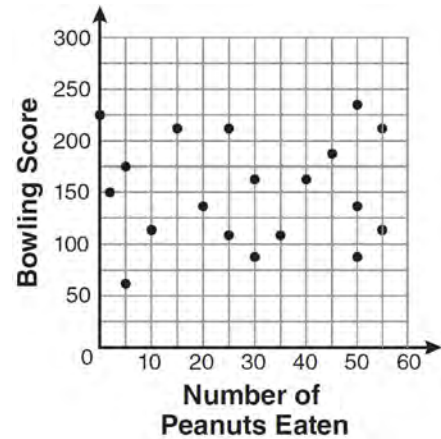

Which conclusion about the scatter plot is valid?

- 1 There is almost no relationship between eating peanuts and bowling score.
- 2 Students who eat more peanuts have higher bowling scores.
- 3 Students who eat more peanuts have lower bowling scores.
- 4 No bowlers eat peanuts.

A.S.17: SCATTER PLOTS

- 61 The number of hours spent on math homework each week and the final exam grades for twelve students in Mr. Dylan's algebra class are plotted below.

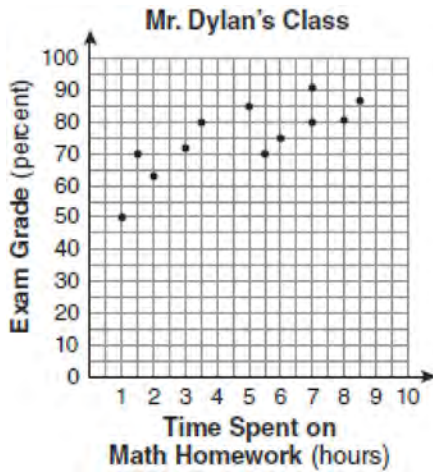

Based on a line of best fit, which exam grade is the best prediction for a student who spends about 4 hours on math homework each week?

- 1 62
- 2 72
- 3 82
- 4 92

- 62 Megan and Bryce opened a new store called the Donut Pit. Their goal is to reach a profit of \$20,000 in their 18th month of business. The table and scatter plot below represent the profit, P , in thousands of dollars, that they made during the first 12 months.

t (months)	P (profit, in thousands of dollars)
1	3.0
2	2.5
3	4.0
4	5.0
5	6.5
6	5.5
7	7.0
8	6.0
9	7.5
10	7.0
11	9.0
12	9.5

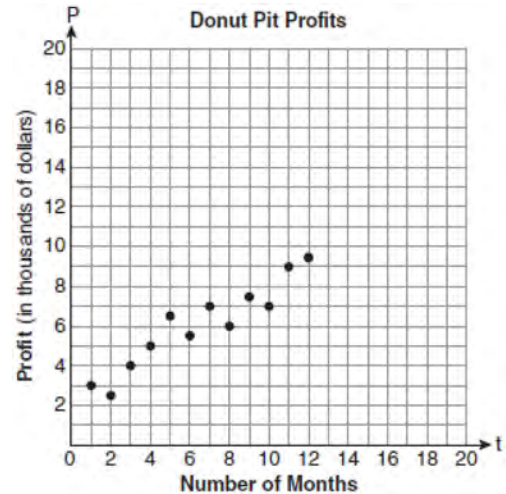

Draw a reasonable line of best fit. Using the line of best fit, predict whether Megan and Bryce will reach their goal in the 18th month of their business. Justify your answer.

A.S.4: CENTRAL TENDENCY

- 63 Which statement is true about the data set 3, 4, 5, 6, 7, 7, 10?
- 1 mean = mode
 - 2 mean > mode
 - 3 mean = median
 - 4 mean < median
- 64 Alex earned scores of 60, 74, 82, 87, 87, and 94 on his first six algebra tests. What is the relationship between the measures of central tendency of these scores?
- 1 median < mode < mean
 - 2 mean < mode < median
 - 3 mode < median < mean
 - 4 mean < median < mode
- 65 Sam's grades on eleven chemistry tests were 90, 85, 76, 63, 94, 89, 81, 76, 78, 69, and 97. Which statement is true about the measures of central tendency?
- 1 mean > mode
 - 2 mean < median
 - 3 mode > median
 - 4 median = mean
- 66 The values of 11 houses on Washington St. are shown in the table below.

Value per House	Number of Houses
\$100,000	1
\$175,000	5
\$200,000	4
\$700,000	1

Find the mean value of these houses in dollars.
 Find the median value of these houses in dollars.
 State which measure of central tendency, the mean or the median, *best* represents the values of these 11 houses. Justify your answer.

- 67 The prices of seven race cars sold last week are listed in the table below.

Price per Race Car	Number of Race Cars
\$126,000	1
\$140,000	2
\$180,000	1
\$400,000	2
\$819,000	1

What is the mean value of these race cars, in dollars? What is the median value of these race cars, in dollars? State which of these measures of central tendency best represents the value of the seven race cars. Justify your answer.

A.S.16: CENTRAL TENDENCY

- 68 Ms. Mosher recorded the math test scores of six students in the table below.

Student	Student Score
Andrew	72
John	80
George	85
Amber	93
Betty	78
Roberto	80

Determine the mean of the student scores, to the *nearest tenth*. Determine the median of the student scores. Describe the effect on the mean and the median if Ms. Mosher adds 5 bonus points to each of the six students' scores.

77 Which data table represents univariate data?

1

Side Length of a Square	Area of Square
2	4
3	9
4	16
5	25

2

Hours Worked	Pay
20	\$160
25	\$200
30	\$240
35	\$280

3

Age Group	Frequency
20–29	9
30–39	7
40–49	10
50–59	4

4

People	Number of Fingers
2	20
3	30
4	40
5	50

78 Which table does *not* show bivariate data?

1

Height (inches)	Weight (pounds)
39	50
48	70
60	90

2

Gallons	Miles Driven
15	300
20	400
25	500

3

Quiz Average	Frequency
70	12
80	15
90	6

4

Speed (mph)	Distance (miles)
40	80
50	120
55	150

A.S.3: ANALYSIS OF DATA

79 A school wants to add a coed soccer program. To determine student interest in the program, a survey will be taken. In order to get an unbiased sample, which group should the school survey?

- 1 every third student entering the building
- 2 every member of the varsity football team
- 3 every member in Ms. Zimmer’s drama classes
- 4 every student having a second-period French class

- 80 A survey is being conducted to determine which types of television programs people watch. Which survey and location combination would likely contain the most bias?
- 1 surveying 10 people who work in a sporting goods store
 - 2 surveying the first 25 people who enter a grocery store
 - 3 randomly surveying 50 people during the day in a mall
 - 4 randomly surveying 75 people during the day in a clothing store

- 81 Erica is conducting a survey about the proposed increase in the sports budget in the Hometown School District. Which survey method would likely contain the most bias?
- 1 Erica asks every third person entering the Hometown Grocery Store.
 - 2 Erica asks every third person leaving the Hometown Shopping Mall this weekend.
 - 3 Erica asks every fifth student entering Hometown High School on Monday morning.
 - 4 Erica asks every fifth person leaving Saturday's Hometown High School football game.

- 82 Four hundred licensed drivers participated in the math club's survey on driving habits. The table below shows the number of drivers surveyed in each age group.

Ages of People in Survey on Driving Habits

Age Group	Number of Drivers
16-25	150
26-35	129
36-45	33
46-55	57
56-65	31

Which statement best describes a conclusion based on the data in the table?

- 1 It may be biased because no one younger than 16 was surveyed.
 - 2 It would be fair because many different age groups were surveyed.
 - 3 It would be fair because the survey was conducted by the math club students.
 - 4 It may be biased because the majority of drivers surveyed were in the younger age intervals.
- 83 A survey is being conducted to determine which school board candidate would best serve the Yonkers community. Which group, when randomly surveyed, would likely produce the most bias?
- 1 15 employees of the Yonkers school district
 - 2 25 people driving past Yonkers High School
 - 3 75 people who enter a Yonkers grocery store
 - 4 100 people who visit the local Yonkers shopping mall

A.S.13: ANALYSIS OF DATA

- 84 Which relationship can best be described as causal?
- 1 height and intelligence
 - 2 shoe size and running speed
 - 3 number of correct answers on a test and test score
 - 4 number of students in a class and number of students with brown hair

A.S.14: ANALYSIS OF DATA

- 85 Which situation describes a correlation that is *not* a causal relationship?
- 1 The rooster crows, and the Sun rises.
 - 2 The more miles driven, the more gasoline needed
 - 3 The more powerful the microwave, the faster the food cooks.
 - 4 The faster the pace of a runner, the quicker the runner finishes.
- 86 Which situation describes a correlation that is *not* a causal relationship?
- 1 the length of the edge of a cube and the volume of the cube
 - 2 the distance traveled and the time spent driving
 - 3 the age of a child and the number of siblings the child has
 - 4 the number of classes taught in a school and the number of teachers employed
- 87 Which phrase best describes the relationship between the number of miles driven and the amount of gasoline used?
- 1 causal, but not correlated
 - 2 correlated, but not causal
 - 3 both correlated and causal
 - 4 neither correlated nor causal
- 88 A study showed that a decrease in the cost of carrots led to an increase in the number of carrots sold. Which statement best describes this relationship?
- 1 positive correlation and a causal relationship
 - 2 negative correlation and a causal relationship
 - 3 positive correlation and not a causal relationship
 - 4 negative correlation and not a causal relationship

- 89 Which situation does *not* describe a causal relationship?
- 1 The higher the volume on a radio, the louder the sound will be.
 - 2 The faster a student types a research paper, the more pages the paper will have.
 - 3 The shorter the distance driven, the less gasoline that will be used.
 - 4 The slower the pace of a runner, the longer it will take the runner to finish the race.

A.M.3: ERROR

- 90 The groundskeeper is replacing the turf on a football field. His measurements of the field are 130 yards by 60 yards. The actual measurements are 120 yards by 54 yards. Which expression represents the relative error in the measurement?
- 1 $\frac{(130)(60) - (120)(54)}{(120)(54)}$
 - 2 $\frac{(130)(60) - (120)(54)}{(120)(54)}$
 - 3 $\frac{(130)(60) - (120)(54)}{(130)(60)}$
 - 4 $\frac{(130)(60) - (120)(54)}{(130)(60)}$
- 91 Carrie bought new carpet for her living room. She calculated the area of the living room to be 174.2 square feet. The actual area was 149.6 square feet. What is the relative error of the area to the *nearest ten-thousandth*?
- 1 0.1412
 - 2 0.1644
 - 3 1.8588
 - 4 2.1644
- 92 Corinne calculated the area of a paper plate to be 50.27 square inches. If the actual area of the plate is 55.42 square inches, what is the relative error in calculating the area, to the *nearest thousandth*?
- 1 0.092
 - 2 0.093
 - 3 0.102
 - 4 0.103

Integrated Algebra Regents Exam Questions by Performance Indicator: Topic

www.jmap.org

- 93 The dimensions of a rectangle are measured to be 12.2 inches by 11.8 inches. The actual dimensions are 12.3 inches by 11.9 inches. What is the relative error, to the *nearest ten-thousandth*, in calculating the area of the rectangle?
- 1 0.0168
 - 2 0.0167
 - 3 0.0165
 - 4 0.0164
- 94 Jack wants to replace the flooring in his rectangular kitchen. He calculates the area of the floor to be 12.8 square meters. The actual area of the floor is 13.5 square meters. What is the relative error in calculating the area of the floor, to the *nearest thousandth*?
- 1 0.051
 - 2 0.052
 - 3 0.054
 - 4 0.055
- 95 The actual dimensions of a rectangle are 2.6 cm by 6.9 cm. Andy measures the sides as 2.5 cm by 6.8 cm. In calculating the area, what is the relative error, to the *nearest thousandth*?
- 1 0.055
 - 2 0.052
 - 3 0.022
 - 4 0.021
- 96 Ryan estimates the measurement of the volume of a popcorn container to be 282 cubic inches. The actual volume of the popcorn container is 289 cubic inches. What is the relative error of Ryan's measurement to the *nearest thousandth*?
- 1 0.024
 - 2 0.025
 - 3 0.096
 - 4 1.025
- 97 To calculate the volume of a small wooden cube, Ezra measured an edge of the cube as 2 cm. The actual length of the edge of Ezra's cube is 2.1 cm. What is the relative error in his volume calculation to the *nearest hundredth*?
- 1 0.13
 - 2 0.14
 - 3 0.15
 - 4 0.16
- 98 Sarah measures her rectangular bedroom window for a new shade. Her measurements are 36 inches by 42 inches. The actual measurements of the window are 36.5 inches and 42.5 inches. Using the measurements that Sarah took, determine the number of square inches in the area of the window. Determine the number of square inches in the actual area of the window. Determine the relative error in calculating the area. Express your answer as a decimal to the *nearest thousandth*.
- 99 Sophie measured a piece of paper to be 21.7 cm by 28.5 cm. The piece of paper is actually 21.6 cm by 28.4 cm. Determine the number of square centimeters in the area of the piece of paper using Sophie's measurements. Determine the number of square centimeters in the actual area of the piece of paper. Determine the relative error in calculating the area. Express your answer as a decimal to the *nearest thousandth*. Sophie does not think there is a significant amount of error. Do you agree or disagree? Justify your answer.
- 100 Alexis calculates the surface area of a gift box as 600 square inches. The actual surface area of the gift box is 592 square inches. Find the relative error of Alexis' calculation expressed as a decimal to the *nearest thousandth*.
- 101 Using his ruler, Howell measured the sides of a rectangular prism to be 5 cm by 8 cm by 4 cm. The actual measurements are 5.3 cm by 8.2 cm by 4.1 cm. Find Howell's relative error in calculating the volume of the prism, to the *nearest thousandth*.

- 102 An oil company distributes oil in a metal can shaped like a cylinder that has an actual radius of 5.1 cm and a height of 15.1 cm. A worker incorrectly measured the radius as 5 cm and the height as 15 cm. Determine the relative error in calculating the surface area, to the *nearest thousandth*.

PROBABILITY

A.S.19: SAMPLE SPACE

- 103 A restaurant sells kids' meals consisting of one main course, one side dish, and one drink, as shown in the table below.

Kids' Meal Choices

Main Course	Side Dish	Drink
hamburger	French fries	milk
chicken nuggets	applesauce	juice
turkey sandwich		soda

Draw a tree diagram or list the sample space showing all possible kids' meals. How many different kids' meals can a person order? Jose does not drink juice. Determine the number of different kids' meals that do *not* include juice. Jose's sister will eat *only* chicken nuggets for her main course. Determine the number of different kids' meals that include chicken nuggets.

- 104 An outfit Jennifer wears to school consists of a top, a bottom, and shoes. Possible choices are listed below.

Tops: T-shirt, blouse, sweater

Bottoms: jeans, skirt, capris

Shoes: flip-flops, sneakers

List the sample space or draw a tree diagram to represent all possible outfits consisting of one type of top, one type of bottom, and one pair of shoes. Determine how many different outfits contain jeans and flip-flops. Determine how many different outfits do *not* include a sweater.

- 105 A sandwich consists of one type of bread, one type of meat, and one type of cheese. The possible choices are listed below.

Bread: white, rye

Meat: ham, turkey, beef

Cheese: American, Swiss

Draw a tree diagram or list a sample space of all the possible different sandwiches consisting of one type of bread, one type of meat, and one type of cheese. Determine the number of sandwiches that will *not* include turkey. Determine the number of sandwiches that will include rye bread and Swiss cheese.

- 106 Clayton has three fair coins. Find the probability that he gets two tails and one head when he flips the three coins.

- 107 Mr. Laub has three children: two girls (Sue and Karen) and one boy (David). After each meal, one child is chosen at random to wash dishes. If the same child can be chosen for both lunch and dinner, construct a tree diagram or list a sample space of all the possible outcomes of who will wash dishes after lunch and dinner on Saturday. Determine the probability that one boy and one girl will wash dishes after lunch and dinner on Saturday.

A.S.21: EXPERIMENTAL PROBABILITY

108 Students in Ms. Nazzeer's mathematics class tossed a six-sided number cube whose faces are numbered 1 to 6. The results are recorded in the table below.

Result	Frequency
1	3
2	6
3	4
4	6
5	4
6	7

Based on these data, what is the empirical probability of tossing a 4?

- 1 $\frac{8}{30}$
- 2 $\frac{6}{30}$
- 3 $\frac{5}{30}$
- 4 $\frac{1}{30}$

109 Three high school juniors, Reese, Matthew, and Chris, are running for student council president. A survey is taken a week before the election asking 40 students which candidate they will vote for in the election. The results are shown in the table below.

Candidate's Name	Number of Students Supporting Candidate
Reese	15
Matthew	13
Chris	12

Based on the table, what is the probability that a student will vote for Reese?

- 1 $\frac{1}{3}$
- 2 $\frac{3}{5}$
- 3 $\frac{3}{8}$
- 4 $\frac{5}{8}$

- 110 A spinner that is equally divided into eight numbered sectors is spun 20 times. The table below shows the number of times the arrow landed in each numbered sector.

Spinner Sector	Number of Times
1	2
2	3
3	2
4	3
5	4
6	2
7	3
8	1

Based on the table, what is the empirical probability that the spinner will land on a prime number on the next spin?

- 1 $\frac{9}{20}$
 - 2 $\frac{11}{20}$
 - 3 $\frac{12}{20}$
 - 4 $\frac{14}{20}$
- 111 Casey purchased a pack of assorted flower seeds and planted them in her garden. When the first 25 flowers bloomed, 11 were white, 5 were red, 3 were blue, and the rest were yellow. Find the empirical probability that a flower that blooms will be yellow.

A.S.20: THEORETICAL PROBABILITY

- 112 A bag contains eight green marbles, five white marbles, and two red marbles. What is the probability of drawing a red marble from the bag?

- 1 $\frac{1}{15}$
- 2 $\frac{2}{15}$
- 3 $\frac{2}{13}$
- 4 $\frac{13}{15}$

A.S.22: THEORETICAL PROBABILITY

- 113 The faces of a cube are numbered from 1 to 6. If the cube is rolled once, which outcome is *least* likely to occur?

- 1 rolling an odd number
- 2 rolling an even number
- 3 rolling a number less than 6
- 4 rolling a number greater than 4

- 114 Maria has a set of 10 index cards labeled with the digits 0 through 9. She puts them in a bag and selects one at random. The outcome that is most likely to occur is selecting

- 1 an odd number
- 2 a prime number
- 3 a number that is at most 5
- 4 a number that is divisible by 3

- 115 Jon is buying tickets for himself for two concerts. For the jazz concert, 4 tickets are available in the front row, and 32 tickets are available in the other rows. For the orchestra concert, 3 tickets are available in the front row, and 23 tickets are available in the other rows. Jon is randomly assigned one ticket for each concert. Determine the concert for which he is more likely to get a front-row ticket. Justify your answer.

- 116 Each of the hats shown below has colored marbles placed inside. Hat A contains five green marbles and four red marbles. Hat B contains six blue marbles and five red marbles. Hat C contains five green marbles and five blue marbles.



If a student were to randomly pick one marble from each of these three hats, determine from which hat the student would most likely pick a green marble. Justify your answer. Determine the fewest number of marbles, if any, and the color of these marbles that could be added to *each* hat so that the probability of picking a green marble will be one-half in each of the three hats.

A.S.23: THEORETICAL PROBABILITY

- 117 Throughout history, many people have contributed to the development of mathematics. These mathematicians include Pythagoras, Euclid, Hypatia, Euler, Einstein, Agnesi, Fibonacci, and Pascal. What is the probability that a mathematician's name selected at random from those listed will start with either the letter *E* or the letter *A*?

- 1 $\frac{2}{8}$
- 2 $\frac{3}{8}$
- 3 $\frac{4}{8}$
- 4 $\frac{6}{8}$

- 118 The faces of a cube are numbered from 1 to 6. If the cube is tossed once, what is the probability that a prime number or a number divisible by 2 is obtained?

- 1 $\frac{6}{6}$
- 2 $\frac{5}{6}$
- 3 $\frac{4}{6}$
- 4 $\frac{1}{6}$

- 119 The probability that it will snow on Sunday is $\frac{3}{5}$. The probability that it will snow on both Sunday and Monday is $\frac{3}{10}$. What is the probability that it will snow on Monday, if it snowed on Sunday?

- 1 $\frac{9}{50}$
- 2 $\frac{2}{2}$
- 3 $\frac{1}{2}$
- 4 $\frac{9}{10}$

- 120 Vince buys a box of candy that consists of six chocolate pieces, four fruit-flavored pieces, and two mint pieces. He selects three pieces of candy at random, without replacement. Calculate the probability that the first piece selected will be fruit flavored and the other two will be mint. Calculate the probability that all three pieces selected will be the same type of candy.

- 121 Three fair coins are tossed. What is the probability that two heads and one tail appear?

- 1 $\frac{1}{8}$
- 2 $\frac{3}{8}$
- 3 $\frac{3}{6}$
- 4 $\frac{2}{3}$

A.S.20: GEOMETRIC PROBABILITY

- 122 The spinner below is divided into eight equal regions and is spun once. What is the probability of *not* getting red?

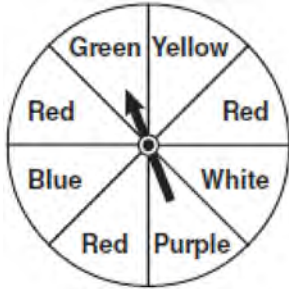

- 1 $\frac{3}{5}$
- 2 $\frac{3}{8}$
- 3 $\frac{5}{8}$
- 4 $\frac{7}{8}$

- 123 The square dart board shown below has a side that measures 40 inches. The shaded portion in the center is a square whose side is 15 inches. A dart thrown at the board is equally likely to land on any point on the dartboard.

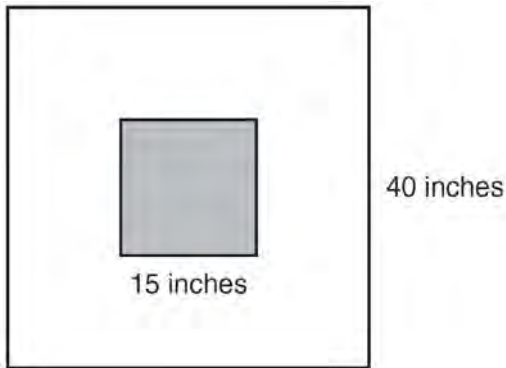

Find the probability that a dart hitting the board will *not* land in the shaded area.

A.S.22: GEOMETRIC PROBABILITY

- 124 A spinner is divided into eight equal regions as shown in the diagram below.

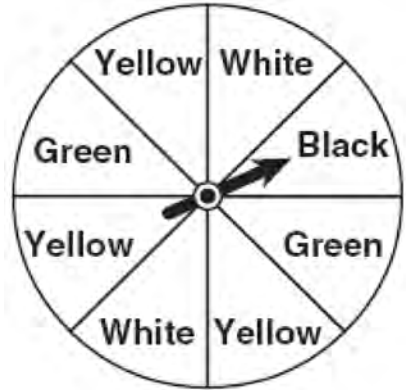

Which event is most likely to occur in one spin?

- 1 The arrow will land in a green or white area.
 - 2 The arrow will land in a green or black area.
 - 3 The arrow will land in a yellow or black area.
 - 4 The arrow will land in a yellow or green area.
- 125 The spinner shown in the diagram below is divided into six equal sections.

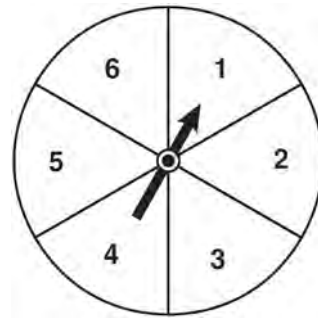

Which outcome is *least* likely to occur on a single spin?

- 1 an odd number
- 2 a prime number
- 3 a perfect square
- 4 a number divisible by 2

A.S.23: GEOMETRIC PROBABILITY

- 126 Keisha is playing a game using a wheel divided into eight equal sectors, as shown in the diagram below. Each time the spinner lands on orange, she will win a prize.

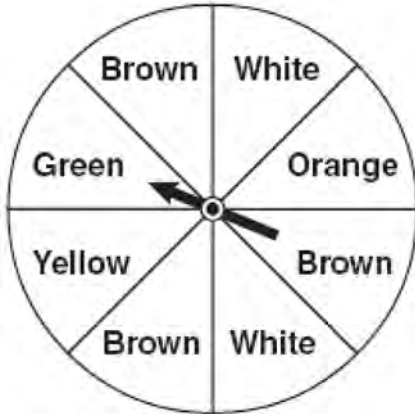

If Keisha spins this wheel twice, what is the probability she will win a prize on *both* spins?

- 1 $\frac{1}{64}$
- 2 $\frac{1}{56}$
- 3 $\frac{1}{16}$
- 4 $\frac{1}{4}$

- 127 Brianna is using the two spinners shown below to play her new board game. She spins the arrow on each spinner once. Brianna uses the first spinner to determine how many spaces to move. She uses the second spinner to determine whether her move from the first spinner will be forward or backward.



Find the probability that Brianna will move *fewer than* four spaces and *backward*.

A.S.18: CONDITIONAL PROBABILITY

- 128 Some books are laid on a desk. Two are English, three are mathematics, one is French, and four are social studies. Theresa selects an English book and Isabelle then selects a social studies book. Both girls take their selections to the library to read. If Truman then selects a book at random, what is the probability that he selects an English book?

A.N.7: MULTIPLICATION COUNTING PRINCIPLE

- 129 How many different sandwiches consisting of one type of cheese, one condiment, and one bread choice can be prepared from five types of cheese, two condiments, and three bread choices?
- 1 10
 - 2 13
 - 3 15
 - 4 30

- 130 The local ice cream stand offers three flavors of soft-serve ice cream: vanilla, chocolate, and strawberry; two types of cone: sugar and wafer; and three toppings: sprinkles, nuts, and cookie crumbs. If Dawn does not order vanilla ice cream, how many different choices can she make that have one flavor of ice cream, one type of cone, and one topping?
- 1 7
 - 2 8
 - 3 12
 - 4 18

A.N.8: PERMUTATIONS

- 131 The bowling team at Lincoln High School must choose a president, vice president, and secretary. If the team has 10 members, which expression could be used to determine the number of ways the officers could be chosen?
- 1 ${}_3P_{10}$
 - 2 ${}_7P_3$
 - 3 ${}_{10}P_3$
 - 4 ${}_{10}P_7$

- 132 How many different ways can five books be arranged on a shelf?
- 1 5
 - 2 15
 - 3 25
 - 4 120

- 133 John is going to line up his four golf trophies on a shelf in his bedroom. How many different possible arrangements can he make?
- 1 24
 - 2 16
 - 3 10
 - 4 4

- 134 How many different three-letter arrangements can be formed using the letters in the word *ABSOLUTE* if each letter is used only once?
- 1 56
 - 2 112
 - 3 168
 - 4 336

- 135 How many different four-letter arrangements are possible with the letters *G, A, R, D, E, N* if each letter may be used only once?
- 1 15
 - 2 24
 - 3 360
 - 4 720

- 136 Determine how many three-letter arrangements are possible with the letters *A, N, G, L, and E* if no letter may be repeated.

- 137 A password consists of three digits, 0 through 9, followed by three letters from an alphabet having 26 letters. If repetition of digits is allowed, but repetition of letters is not allowed, determine the number of different passwords that can be made. If repetition is not allowed for digits or letters, determine how many fewer different passwords can be made.

EXPRESSIONS AND EQUATIONS

A.A.1: EXPRESSIONS

- 138 Mr. Turner bought x boxes of pencils. Each box holds 25 pencils. He left 3 boxes of pencils at home and took the rest to school. Which expression represents the total number of pencils he took to school?
- 1 $22x$
 - 2 $25x - 3$
 - 3 $25 - 3x$
 - 4 $25x - 75$

Integrated Algebra Regents Exam Questions by Performance Indicator: Topic

www.jmap.org

- 139 Marie currently has a collection of 58 stamps. If she buys s stamps each week for w weeks, which expression represents the total number of stamps she will have?

- 1 $58sw$
- 2 $58 + sw$
- 3 $58s + w$
- 4 $58 + s + w$

- 140 Tim ate four more cookies than Alice. Bob ate twice as many cookies as Tim. If x represents the number of cookies Alice ate, which expression represents the number of cookies Bob ate?

- 1 $2 + (x + 4)$
- 2 $2x + 4$
- 3 $2(x + 4)$
- 4 $4(x + 2)$

- 141 Which algebraic expression represents 15 less than x divided by 9?

- 1 $\frac{x}{9} - 15$
- 2 $9x - 15$
- 3 $15 - \frac{x}{9}$
- 4 $15 - 9x$

- 142 Timmy bought a skateboard and two helmets for a total of d dollars. If each helmet cost h dollars, the cost of the skateboard could be represented by

- 1 $2dh$
- 2 $\frac{dh}{2}$
- 3 $d - 2h$
- 4 $d - \frac{h}{2}$

- 143 What is the perimeter of a regular pentagon with a side whose length is $x + 4$?

- 1 $x^2 + 16$
- 2 $4x + 16$
- 3 $5x + 4$
- 4 $5x + 20$

- 144 The length of a rectangular room is 7 less than three times the width, w , of the room. Which expression represents the area of the room?

- 1 $3w - 4$
- 2 $3w - 7$
- 3 $3w^2 - 4w$
- 4 $3w^2 - 7w$

A.A.2: EXPRESSIONS

- 145 Which verbal expression represents $2(n - 6)$?

- 1 two times n minus six
- 2 two times six minus n
- 3 two times the quantity n less than six
- 4 two times the quantity six less than n

- 146 Which verbal expression can be represented by $2(x - 5)$?

- 1 5 less than 2 times x
- 2 2 multiplied by x less than 5
- 3 twice the difference of x and 5
- 4 the product of 2 and x , decreased by 5

- 147 Which verbal expression is represented by $\frac{1}{2}(n - 3)$?

- 1 one-half n decreased by 3
- 2 one-half n subtracted from 3
- 3 the difference of one-half n and 3
- 4 one-half the difference of n and 3

A.A.3: EXPRESSIONS

- 148 An example of an algebraic expression is

- 1 $\frac{2x + 3}{7} = \frac{13}{x}$
- 2 $(2x + 1)(x - 7)$
- 3 $4x - 1 = 4$
- 4 $x = 2$

- 149 An example of an algebraic expression is

- 1 $x + 2$
- 2 $y = x + 2$
- 3 $y < x + 2$
- 4 $y = x^2 + 2x$

150 An example of an algebraic expression is

- 1 $y = mx + b$
- 2 $3x + 4y - 7$
- 3 $2x + 3y \leq 18$
- 4 $(x + y)(x - y) = 25$

151 Mr. Stanton asked his students to write an algebraic expression on a piece of paper. He chose four students to go to the board and write their expression.

Robert wrote: $4(2x + 5) \geq 17$

Meredith wrote: $3y - 7 + 11z$

Steven wrote: $9w + 2 = 20$

Cynthia wrote: $8 + 10 - 4 = 14$

Which student wrote an algebraic expression?

- 1 Robert
- 2 Meredith
- 3 Steven
- 4 Cynthia

152 Chad complained to his friend that he had five equations to solve for homework. Are all of the homework problems equations? Justify your answer.

Math Homework

1. $3x^2 \cdot 2x^4$
2. $5 - 2x = 3x$
3. $3(2x + 7)$
4. $7x^2 + 2x - 3x^2 - 9$
5. $\frac{2}{3} = \frac{x+2}{6}$

Name Chad

A.A.22: SOLVING EQUATIONS

153 Which value of p is the solution of $5p - 1 = 2p + 20$?

- 1 $\frac{19}{7}$
- 2 $\frac{19}{3}$
- 3 3
- 4 7

154 What is the value of x in the equation $2(x - 4) = 4(2x + 1)$?

- 1 -2
- 2 2
- 3 $-\frac{1}{2}$
- 4 $\frac{1}{2}$

155 Debbie solved the linear equation $3(x + 4) - 2 = 16$ as follows:

[Line 1] $3(x + 4) - 2 = 16$

[Line 2] $3(x + 4) = 18$

[Line 3] $3x + 4 = 18$

[Line 4] $3x = 14$

[Line 5] $x = 4\frac{2}{3}$

She made an error between lines

- 1 1 and 2
- 2 2 and 3
- 3 3 and 4
- 4 4 and 5

156 Solve for g : $3 + 2g = 5g - 9$

A.A.25: SOLVING EQUATIONS WITH FRACTIONAL EXPRESSIONS

157 Which value of x is the solution of the equation

$$\frac{2x}{3} + \frac{x}{6} = 5?$$

- 1 6
- 2 10
- 3 15
- 4 30

158 Which value of x is the solution of the equation

$$\frac{2}{3}x + \frac{1}{2} = \frac{5}{6}?$$

- 1 $\frac{1}{2}$
- 2 2
- 3 $\frac{2}{3}$
- 4 $\frac{3}{2}$

159 Solve for x : $\frac{3}{5}(x+2) = x-4$

- 1 8
- 2 13
- 3 15
- 4 23

160 Which value of x is the solution of $\frac{x}{3} + \frac{x+1}{2} = x$?

- 1 1
- 2 -1
- 3 3
- 4 -3

161 Which value of x is the solution of

$$\frac{2x}{5} + \frac{1}{3} = \frac{7x-2}{15}?$$

- 1 $\frac{3}{5}$
- 2 $\frac{31}{26}$
- 3 3
- 4 7

162 Solve for m : $\frac{m}{5} + \frac{3(m-1)}{2} = 2(m-3)$

A.A.4: MODELING EQUATIONS

163 If h represents a number, which equation is a correct translation of "Sixty more than 9 times a number is 375"?

- 1 $9h = 375$
- 2 $9h + 60 = 375$
- 3 $9h - 60 = 375$
- 4 $60h + 9 = 375$

A.A.5: MODELING EQUATIONS

164 Rhonda has \$1.35 in nickels and dimes in her pocket. If she has six more dimes than nickels, which equation can be used to determine x , the number of nickels she has?

- 1 $0.05(x+6) + 0.10x = 1.35$
- 2 $0.05x + 0.10(x+6) = 1.35$
- 3 $0.05 + 0.10(6x) = 1.35$
- 4 $0.15(x+6) = 1.35$

165 The width of a rectangle is 3 less than twice the length, x . If the area of the rectangle is 43 square feet, which equation can be used to find the length, in feet?

- 1 $2x(x-3) = 43$
- 2 $x(3-2x) = 43$
- 3 $2x + 2(2x-3) = 43$
- 4 $x(2x-3) = 43$

166 The length of a rectangular window is 5 feet more than its width, w . The area of the window is 36 square feet. Which equation could be used to find the dimensions of the window?

- 1 $w^2 + 5w + 36 = 0$
- 2 $w^2 - 5w - 36 = 0$
- 3 $w^2 - 5w + 36 = 0$
- 4 $w^2 + 5w - 36 = 0$

A.A.6: MODELING EQUATIONS

167 The ages of three brothers are consecutive even integers. Three times the age of the youngest brother exceeds the oldest brother's age by 48 years. What is the age of the youngest brother?

- 1 14
- 2 18
- 3 22
- 4 26

168 The sum of three consecutive odd integers is 18 less than five times the middle number. Find the three integers. [Only an algebraic solution can receive full credit.]

169 If $3ax + b = c$, then x equals

- 1 $c - b + 3a$
- 2 $c + b - 3a$
- 3 $\frac{c - b}{3a}$
- 4 $\frac{b - c}{3a}$

170 If the formula for the perimeter of a rectangle is $P = 2l + 2w$, then w can be expressed as

- 1 $w = \frac{2l - P}{2}$
- 2 $w = \frac{P - 2l}{2}$
- 3 $w = \frac{P - l}{2}$
- 4 $w = \frac{P - 2w}{2l}$

171 The members of the senior class are planning a dance. They use the equation $r = pn$ to determine the total receipts. What is n expressed in terms of r and p ?

- 1 $n = r + p$
- 2 $n = r - p$
- 3 $n = \frac{p}{r}$
- 4 $n = \frac{r}{p}$

172 A formula used for calculating velocity is

$$v = \frac{1}{2}at^2. \text{ What is } a \text{ expressed in terms of } v \text{ and } t?$$

- 1 $a = \frac{2v}{t}$
- 2 $a = \frac{2v}{t^2}$
- 3 $a = \frac{v}{t}$
- 4 $a = \frac{v}{2t^2}$

173 If $s = \frac{2x + t}{r}$, then x equals

- 1 $\frac{rs - t}{2}$
- 2 $\frac{rs + 1}{2}$
- 3 $2rs - t$
- 4 $rs - 2t$

174 If $\frac{ey}{n} + k = t$, what is y in terms of e , n , k , and t ?

- 1 $y = \frac{tn + k}{e}$
- 2 $y = \frac{tn - k}{e}$
- 3 $y = \frac{n(t + k)}{e}$
- 4 $y = \frac{n(t - k)}{e}$

175 If $a + ar = b + r$, the value of a in terms of b and r can be expressed as

- 1 $\frac{b}{r} + 1$
- 2 $\frac{1 + b}{r}$
- 3 $\frac{b + r}{1 + r}$
- 4 $\frac{1 + b}{r + b}$

176 Solve for c in terms of a and b : $bc + ac = ab$

Integrated Algebra Regents Exam Questions by Performance Indicator: Topic

RATE

A.M.1: USING RATE

- 177 Nicole's aerobics class exercises to fast-paced music. If the rate of the music is 120 beats per minute, how many beats would there be in a class that is 0.75 hour long?
- 1 90
 - 2 160
 - 3 5,400
 - 4 7,200
- 178 Joseph typed a 1,200-word essay in 25 minutes. At this rate, determine how many words he can type in 45 minutes.
- 179 Tom drove 290 miles from his college to home and used 23.2 gallons of gasoline. His sister, Ann, drove 225 miles from her college to home and used 15 gallons of gasoline. Whose vehicle had better gas mileage? Justify your answer.

A.M.1: SPEED

- 180 What is the speed, in meters per second, of a paper airplane that flies 24 meters in 6 seconds?
- 1 144
 - 2 30
 - 3 18
 - 4 4
- 181 Steve ran a distance of 150 meters in $1\frac{1}{2}$ minutes. What is his speed in meters per hour?
- 1 6
 - 2 60
 - 3 100
 - 4 6,000

- 182 A hiker walked 12.8 miles from 9:00 a.m. to noon. He walked an additional 17.2 miles from 1:00 p.m. to 6:00 p.m. What is his average rate for the entire walk, in miles per hour?
- 1 3.75
 - 2 3.86
 - 3 4.27
 - 4 7.71
- 183 It takes Tammy 45 minutes to ride her bike 5 miles. At this rate, how long will it take her to ride 8 miles?
- 1 0.89 hour
 - 2 1.125 hours
 - 3 48 minutes
 - 4 72 minutes

- 184 In a game of ice hockey, the hockey puck took 0.8 second to travel 89 feet to the goal line. Determine the average speed of the puck in feet per second.

- 185 The chart below compares two runners.

Runner	Distance, in miles	Time, in hours
Greg	11	2
Dave	16	3

Based on the information in this chart, state which runner has the faster rate. Justify your answer.

- 186 A turtle and a rabbit are in a race to see who is first to reach a point 100 feet away. The turtle travels at a constant speed of 20 feet per minute for the entire 100 feet. The rabbit travels at a constant speed of 40 feet per minute for the first 50 feet, stops for 3 minutes, and then continues at a constant speed of 40 feet per minute for the last 50 feet. Determine which animal won the race and by how much time.

- 187 Hannah took a trip to visit her cousin. She drove 120 miles to reach her cousin's house and the same distance back home. It took her 1.2 hours to get halfway to her cousin's house. What was her average speed, in miles per hour, for the first 1.2 hours of the trip? Hannah's average speed for the remainder of the trip to her cousin's house was 40 miles per hour. How long, in hours, did it take her to drive the remaining distance? Traveling home along the same route, Hannah drove at an average rate of 55 miles per hour. After 2 hours her car broke down. How many miles was she from home?

A.M.2: CONVERSIONS

- 188 On a certain day in Toronto, Canada, the temperature was 15° Celsius (C). Using the formula $F = \frac{9}{5}C + 32$, Peter converts this temperature to degrees Fahrenheit (F). Which temperature represents 15°C in degrees Fahrenheit?
- 1 -9
 - 2 35
 - 3 59
 - 4 85

- 189 If the speed of sound is 344 meters per second, what is the approximate speed of sound, in meters per hour?

60 seconds = 1 minute
60 minutes = 1 hour

- 1 20,640
- 2 41,280
- 3 123,840
- 4 1,238,400

- 190 Angela wants to purchase carpeting for her living room. The dimensions of her living room are 12 feet by 12 feet. If carpeting is sold by the square yard, determine how many square yards of carpeting she must purchase.

3 feet = 1 yard
9 square feet = 1 square yard

- 191 Mrs. Chen owns two pieces of property. The areas of the properties are 77,120 square feet and 33,500 square feet.

43,560 square feet = 1 acre

Find the total number of acres Mrs. Chen owns, to the *nearest hundredth of an acre*.

- 192 Roberta needs ribbon for a craft project. The ribbon sells for \$3.75 per yard. Find the cost, in dollars, for 48 inches of the ribbon.

A.N.5: PERCENTS

- 193 In a recent town election, 1,860 people voted for either candidate A or candidate B for the position of supervisor. If candidate A received 55% of the votes, how many votes did candidate B receive?

- 1 186
- 2 837
- 3 1,023
- 4 1,805

- 194 The Hudson Record Store is having a going-out-of-business sale. CDs normally sell for \$18.00. During the first week of the sale, all CDs will sell for \$15.00. Written as a fraction, what is the rate of discount? What is this rate expressed as a percent? Round your answer to the *nearest hundredth of a percent*. During the second week of the sale, the same CDs will be on sale for 25% off the *original price*. What is the price of a CD during the second week of the sale?

195 At the end of week one, a stock had increased in value from \$5.75 a share to \$7.50 a share. Find the percent of increase at the end of week one to the *nearest tenth of a percent*. At the end of week two, the same stock had decreased in value from \$7.50 to \$5.75. Is the percent of decrease at the end of week two the same as the percent of increase at the end of week one? Justify your answer.

196 Shana wants to buy a new bicycle that has a retail price of \$259.99. She knows that it will be on sale next week for 30% off the retail price. If the tax rate is 7%, find the total amount, to the *nearest cent*, that she will save by waiting until next week.

A.N.5: DIRECT VARIATION

197 The number of calories burned while jogging varies directly with the number of minutes spent jogging. If George burns 150 calories by jogging for 20 minutes, how many calories does he burn by jogging for 30 minutes?

- 1 100
- 2 180
- 3 200
- 4 225

198 The table below represents the number of hours a student worked and the amount of money the student earned.

Number of Hours (h)	Dollars Earned (d)
8	\$50.00
15	\$93.75
19	\$118.75
30	\$187.50

Write an equation that represents the number of dollars, d , earned in terms of the number of hours, h , worked. Using this equation, determine the number of dollars the student would earn for working 40 hours.

LINEAR EQUATIONS

A.A.32: SLOPE

199 In a linear equation, the independent variable increases at a constant rate while the dependent variable decreases at a constant rate. The slope of this line is

- 1 zero
- 2 negative
- 3 positive
- 4 undefined

- 200 The data in the table below are graphed, and the slope is examined.

x	y
0.5	9.0
1	8.75
1.5	8.5
2	8.25
2.5	8.0

The rate of change represented in this table can be described as

- 1 negative
- 2 positive
- 3 undefined
- 4 zero

A.A.33: SLOPE

- 201 In the diagram below, what is the slope of the line passing through points *A* and *B*?

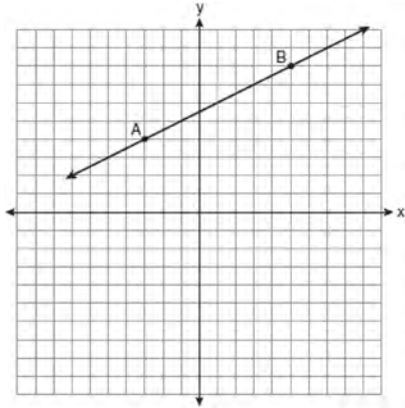

- 1 -2
- 2 2
- 3 $-\frac{1}{2}$
- 4 $\frac{1}{2}$

- 202 What is the slope of the line passing through the points *A* and *B*, as shown on the graph below?

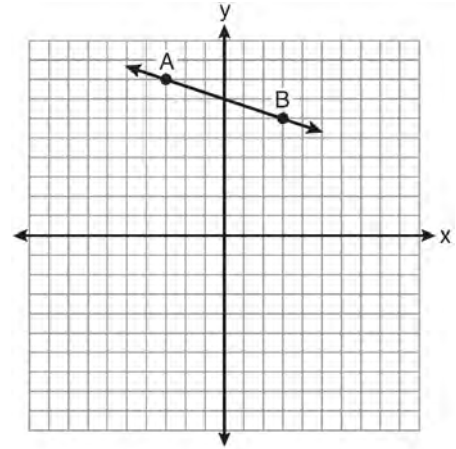

- 1 -3
- 2 $-\frac{1}{3}$
- 3 3
- 4 $\frac{1}{3}$

- 203 What is the slope of the line containing the points (3,4) and (-6,10)?

- 1 $\frac{1}{2}$
- 2 2
- 3 $-\frac{2}{3}$
- 4 $-\frac{3}{2}$

- 204 What is the slope of the line that passes through the points (-6,1) and (4,-4)?

- 1 -2
- 2 2
- 3 $-\frac{1}{2}$
- 4 $\frac{1}{2}$

205 What is the slope of the line that passes through the points (2,5) and (7,3)?

- 1 $-\frac{5}{2}$
- 2 $-\frac{2}{5}$
- 3 $\frac{8}{9}$
- 4 $\frac{9}{8}$

206 What is the slope of the line that passes through the points (-5,4) and (15,-4)?

- 1 $-\frac{2}{5}$
- 2 0
- 3 $-\frac{5}{2}$
- 4 undefined

207 What is the slope of the line that passes through the points (3,5) and (-2,2)?

- 1 $\frac{1}{5}$
- 2 $\frac{3}{5}$
- 3 $\frac{5}{3}$
- 4 5

208 What is the slope of the line passing through the points (-2,4) and (3,6)?

- 1 $-\frac{5}{2}$
- 2 $-\frac{2}{5}$
- 3 $\frac{2}{5}$
- 4 $\frac{5}{2}$

209 What is the slope of the line that passes through the points (2,-3) and (5,1)?

- 1 $-\frac{2}{3}$
- 2 $\frac{2}{3}$
- 3 $-\frac{4}{3}$
- 4 $\frac{4}{3}$

A.A.37: SLOPE

210 What is the slope of the line whose equation is $3x - 7y = 9$?

- 1 $-\frac{3}{7}$
- 2 $\frac{3}{7}$
- 3 $-\frac{7}{3}$
- 4 $\frac{7}{3}$

A.G.4: GRAPHING LINEAR FUNCTIONS

- 211 The gas tank in a car holds a total of 16 gallons of gas. The car travels 75 miles on 4 gallons of gas. If the gas tank is full at the beginning of a trip, which graph represents the rate of change in the amount of gas in the tank?

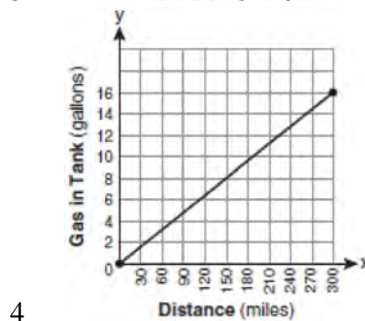
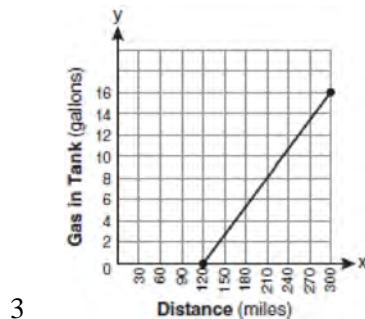
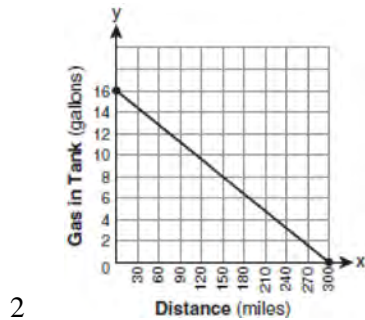
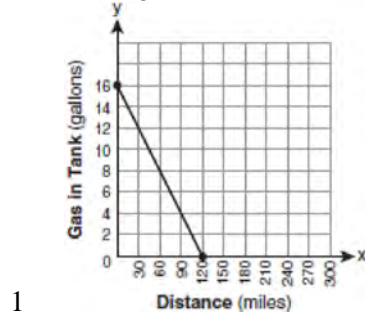

A.A.34: WRITING LINEAR EQUATIONS

- 212 What is an equation of the line that passes through the point $(4, -6)$ and has a slope of -3 ?
- 1 $y = -3x + 6$
 - 2 $y = -3x - 6$
 - 3 $y = -3x + 10$
 - 4 $y = -3x + 14$
- 213 What is an equation of the line that passes through the point $(3, -1)$ and has a slope of 2 ?
- 1 $y = 2x + 5$
 - 2 $y = 2x - 1$
 - 3 $y = 2x - 4$
 - 4 $y = 2x - 7$
- 214 Which equation represents the line that passes through the point $(1, 5)$ and has a slope of -2 ?
- 1 $y = -2x + 7$
 - 2 $y = -2x + 11$
 - 3 $y = 2x - 9$
 - 4 $y = 2x + 3$
- 215 A line having a slope of $\frac{3}{4}$ passes through the point $(-8, 4)$. Write the equation of this line in slope-intercept form.

A.A.35: WRITING LINEAR EQUATIONS

- 216 What is an equation of the line that passes through the points $(3, -3)$ and $(-3, -3)$?
- 1 $y = 3$
 - 2 $x = -3$
 - 3 $y = -3$
 - 4 $x = y$

Integrated Algebra Regents Exam Questions by Performance Indicator: Topic

www.jmap.org

217 What is an equation for the line that passes through the coordinates (2,0) and (0,3)?

1 $y = -\frac{3}{2}x + 3$

2 $y = -\frac{3}{2}x - 3$

3 $y = -\frac{2}{3}x + 2$

4 $y = -\frac{2}{3}x - 2$

218 Which equation represents the line that passes through the points (-3,7) and (3,3)?

1 $y = \frac{2}{3}x + 1$

2 $y = \frac{2}{3}x + 9$

3 $y = -\frac{2}{3}x + 5$

4 $y = -\frac{2}{3}x + 9$

219 What is an equation of the line that passes through the points (1,3) and (8,5)?

1 $y + 1 = \frac{2}{7}(x + 3)$

2 $y - 5 = \frac{2}{7}(x - 8)$

3 $y - 1 = \frac{2}{7}(x + 3)$

4 $y + 5 = \frac{2}{7}(x - 8)$

220 Write an equation that represents the line that passes through the points (5,4) and (-5,0).

A.A.39: IDENTIFYING POINTS ON A LINE

221 Which point is on the line $4y - 2x = 0$?

1 (-2,-1)

2 (-2,1)

3 (-1,-2)

4 (1,2)

222 Which point lies on the line whose equation is $2x - 3y = 9$?

1 (-1,-3)

2 (-1,3)

3 (0,3)

4 (0,-3)

223 Which point lies on the graph represented by the equation $3y + 2x = 8$?

1 (-2,7)

2 (0,4)

3 (2,4)

4 (7,-2)

224 Which linear equation represents a line containing the point (1,3)?

1 $x + 2y = 5$

2 $x - 2y = 5$

3 $2x + y = 5$

4 $2x - y = 5$

A.A.36: PARALLEL AND PERPENDICULAR LINES

225 Which equation represents a line parallel to the x -axis?

1 $x = 5$

2 $y = 10$

3 $x = \frac{1}{3}y$

4 $y = 5x + 17$

226 Which equation represents a line parallel to the x -axis?

1 $y = -5$

2 $y = -5x$

3 $x = 3$

4 $x = 3y$

227 Which equation represents a line parallel to the y -axis?

- 1 $x = y$
- 2 $x = 4$
- 3 $y = 4$
- 4 $y = x + 4$

228 Which equation represents a line parallel to the y -axis?

- 1 $y = x$
- 2 $y = 3$
- 3 $x = -y$
- 4 $x = -4$

A.A.38: PARALLEL AND PERPENDICULAR LINES

229 Which equation represents a line that is parallel to the line $y = -4x + 5$?

- 1 $y = -4x + 3$
- 2 $y = -\frac{1}{4}x + 5$
- 3 $y = \frac{1}{4}x + 3$
- 4 $y = 4x + 5$

230 Which equation represents a line that is parallel to the line $y = 3 - 2x$?

- 1 $4x + 2y = 5$
- 2 $2x + 4y = 1$
- 3 $y = 3 - 4x$
- 4 $y = 4x - 2$

231 Which equation represents a line parallel to the graph of $2x - 4y = 16$?

- 1 $y = \frac{1}{2}x - 5$
- 2 $y = -\frac{1}{2}x + 4$
- 3 $y = -2x + 6$
- 4 $y = 2x + 8$

232 The graphs of the equations $y = 2x - 7$ and $y - kx = 7$ are parallel when k equals

- 1 -2
- 2 2
- 3 -7
- 4 7

INEQUALITIES

A.A.24: SOLVING INEQUALITIES

233 What is the solution of the inequality $-6x - 17 \geq 8x + 25$?

- 1 $x \geq 3$
- 2 $x \leq 3$
- 3 $x \geq -3$
- 4 $x \leq -3$

234 What is the solution of $3(2m - 1) \leq 4m + 7$?

- 1 $m \leq 5$
- 2 $m \geq 5$
- 3 $m \leq 4$
- 4 $m \geq 4$

235 Solve algebraically for x : $2(x - 4) \geq \frac{1}{2}(5 - 3x)$

A.A.21: INTERPRETING SOLUTIONS

236 Which value of x is in the solution set of the inequality $-2x + 5 > 17$?

- 1 -8
- 2 -6
- 3 -4
- 4 12

237 Which value of x is in the solution set of the inequality $-4x + 2 > 10$?

- 1 -2
- 2 2
- 3 3
- 4 -4

- 238 Which value of x is in the solution set of

$$\frac{4}{3}x + 5 < 17?$$

- 1 8
- 2 9
- 3 12
- 4 16

- 239 Which value of x is in the solution set of the inequality $-2(x - 5) < 4$?

- 1 0
- 2 2
- 3 3
- 4 5

- 240 Given: $A = \{18, 6, -3, -12\}$
Determine all elements of set A that are in the solution of the inequality $\frac{2}{3}x + 3 < -2x - 7$.

A.A.4: MODELING INEQUALITIES

- 241 Mrs. Smith wrote "Eight less than three times a number is greater than fifteen" on the board. If x represents the number, which inequality is a correct translation of this statement?

- 1 $3x - 8 > 15$
- 2 $3x - 8 < 15$
- 3 $8 - 3x > 15$
- 4 $8 - 3x < 15$

- 242 The sign shown below is posted in front of a roller coaster ride at the Wadsworth County Fairgrounds.

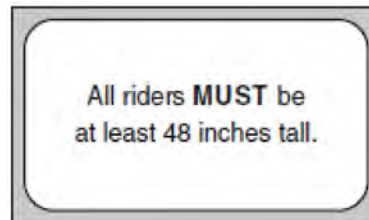

If h represents the height of a rider in inches, what is a correct translation of the statement on this sign?

- 1 $h < 48$
- 2 $h > 48$
- 3 $h \leq 48$
- 4 $h \geq 48$

A.A.5: MODELING INEQUALITIES

- 243 Students in a ninth grade class measured their heights, h , in centimeters. The height of the shortest student was 155 cm, and the height of the tallest student was 190 cm. Which inequality represents the range of heights?

- 1 $155 < h < 190$
- 2 $155 \leq h \leq 190$
- 3 $h \geq 155$ or $h \leq 190$
- 4 $h > 155$ or $h < 190$

- 244 Roger is having a picnic for 78 guests. He plans to serve each guest at least one hot dog. If each package, p , contains eight hot dogs, which inequality could be used to determine how many packages of hot dogs Roger will need to buy?

- 1 $p \geq 78$
- 2 $8p \geq 78$
- 3 $8 + p \geq 78$
- 4 $78 - p \geq 8$

- 245 An electronics store sells DVD players and cordless telephones. The store makes a \$75 profit on the sale of each DVD player (d) and a \$30 profit on the sale of each cordless telephone (c). The store wants to make a profit of at least \$255.00 from its sales of DVD players and cordless phones. Which inequality describes this situation?
- 1 $75d + 30c < 255$
 - 2 $75d + 30c \leq 255$
 - 3 $75d + 30c > 255$
 - 4 $75d + 30c \geq 255$
- 246 The ninth grade class at a local high school needs to purchase a park permit for \$250.00 for their upcoming class picnic. Each ninth grader attending the picnic pays \$0.75. Each guest pays \$1.25. If 200 ninth graders attend the picnic, which inequality can be used to determine the number of guests, x , needed to cover the cost of the permit?
- 1 $0.75x - (1.25)(200) \geq 250.00$
 - 2 $0.75x + (1.25)(200) \geq 250.00$
 - 3 $(0.75)(200) - 1.25x \geq 250.00$
 - 4 $(0.75)(200) + 1.25x \geq 250.00$
- 249 A prom ticket at Smith High School is \$120. Tom is going to save money for the ticket by walking his neighbor's dog for \$15 per week. If Tom already has saved \$22, what is the minimum number of weeks Tom must walk the dog to earn enough to pay for the prom ticket?
- 250 Peter begins his kindergarten year able to spell 10 words. He is going to learn to spell 2 new words every day. Write an inequality that can be used to determine how many days, d , it takes Peter to be able to spell *at least* 75 words. Use this inequality to determine the minimum number of whole days it will take for him to be able to spell *at least* 75 words.
- 251 Chelsea has \$45 to spend at the fair. She spends \$20 on admission and \$15 on snacks. She wants to play a game that costs \$0.65 per game. Write an inequality to find the maximum number of times, x , Chelsea can play the game. Using this inequality, determine the maximum number of times she can play the game.

A.A.6: MODELING INEQUALITIES

- 247 Tamara has a cell phone plan that charges \$0.07 per minute plus a monthly fee of \$19.00. She budgets \$29.50 per month for total cell phone expenses without taxes. What is the maximum number of minutes Tamara could use her phone each month in order to stay within her budget?
- 1 150
 - 2 271
 - 3 421
 - 4 692
- 248 An online music club has a one-time registration fee of \$13.95 and charges \$0.49 to buy each song. If Emma has \$50.00 to join the club and buy songs, what is the maximum number of songs she can buy?
- 1 73
 - 2 74
 - 3 130
 - 4 131

A.G.6: LINEAR INEQUALITIES

- 252 Which quadrant will be completely shaded in the graph of the inequality $y \leq 2x$?
- 1 Quadrant I
 - 2 Quadrant II
 - 3 Quadrant III
 - 4 Quadrant IV

253 Which graph represents the inequality $y > 3$?

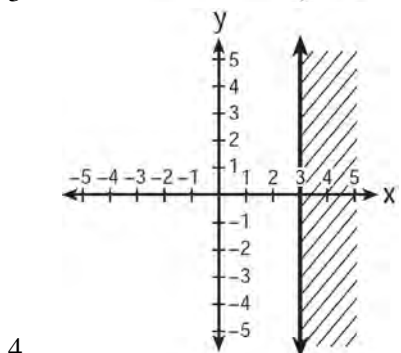
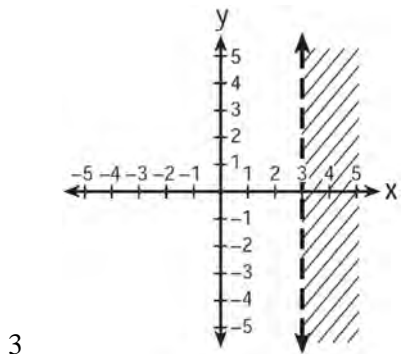
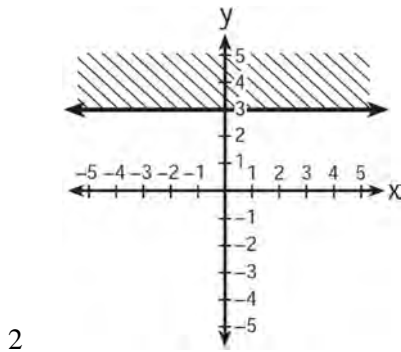
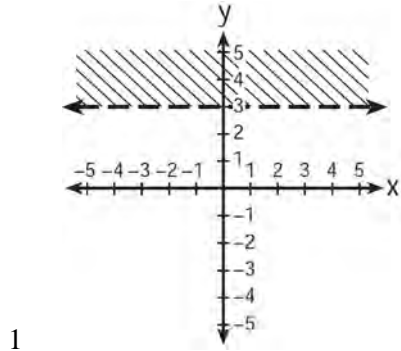

254 Which graph represents the solution of $3y - 9 \leq 6x$?

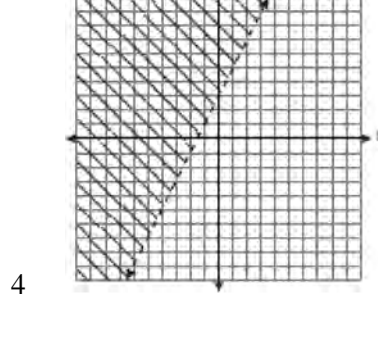
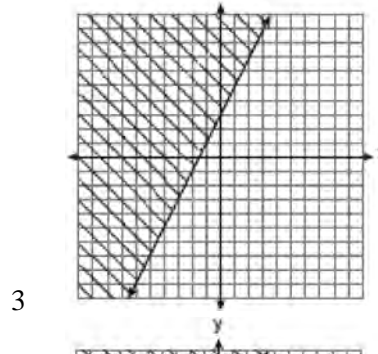
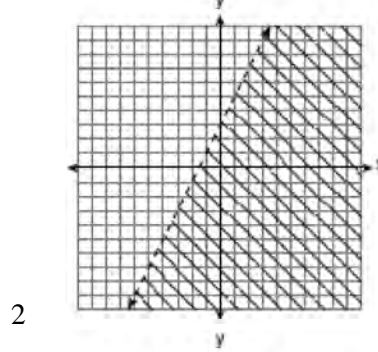
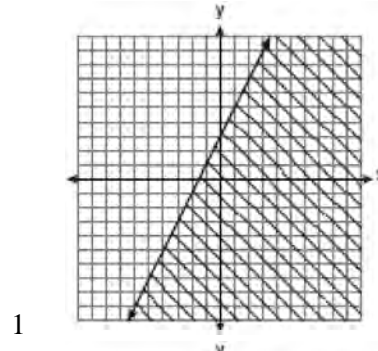

255 Which inequality is represented by the graph below?

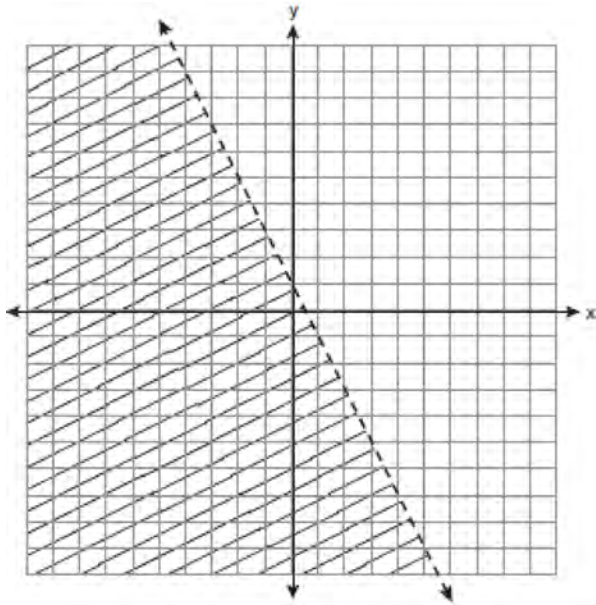

- 1 $y < 2x + 1$
- 2 $y < -2x + 1$
- 3 $y < \frac{1}{2}x + 1$
- 4 $y < -\frac{1}{2}x + 1$

256 Graph the solution set for the inequality $4x - 3y > 9$ on the set of axes below. Determine if the point $(1, -3)$ is in the solution set. Justify your answer.

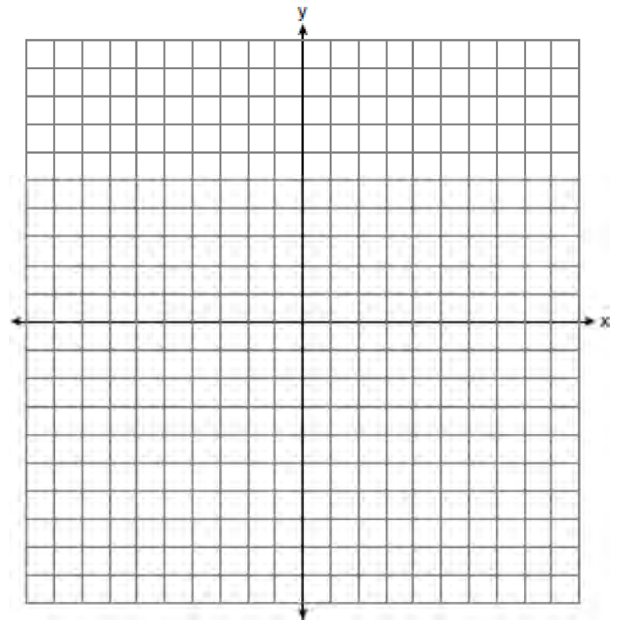

ABSOLUTE VALUE

A.G.4: GRAPHING ABSOLUTE VALUE FUNCTIONS

257 Which is the graph of $y = |x| + 2$?

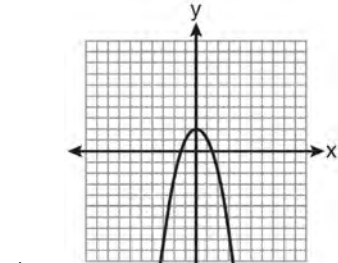
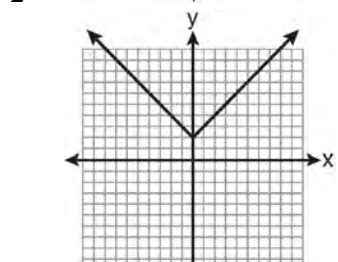
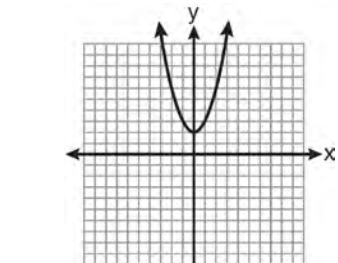
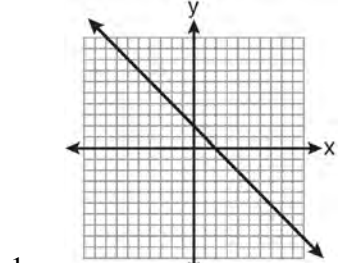

A.G.5: GRAPHING ABSOLUTE VALUE FUNCTIONS

258 The graph of $y = |x + 2|$ is shown below.

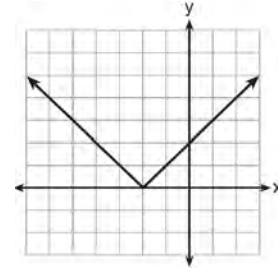

Which graph represents $y = -|x + 2|$?

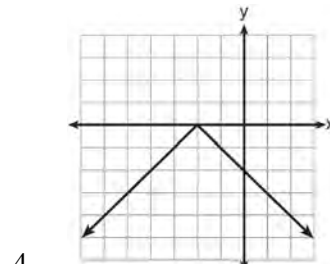
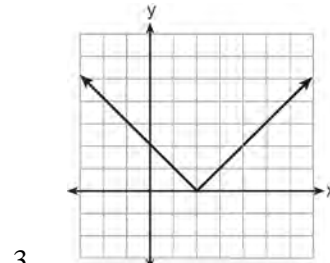
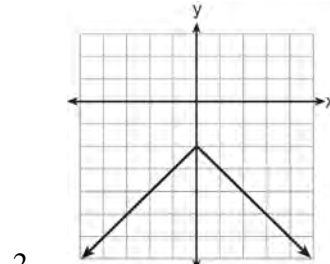
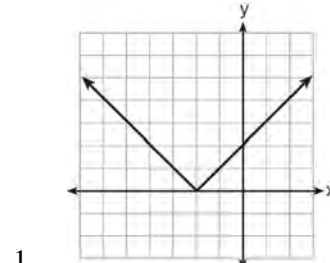

259 The diagram below shows the graph of $y = |x - 3|$.

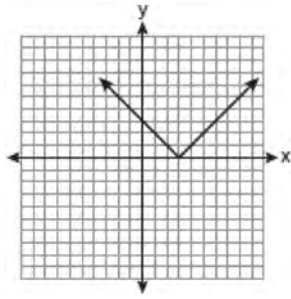

260 The graph of the equation $y = |x|$ is shown in the diagram below.

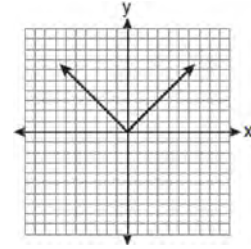

Which diagram shows the graph of $y = -|x - 3|$?

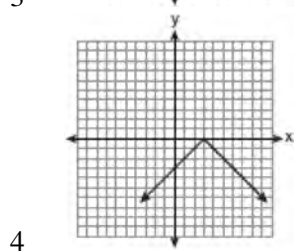
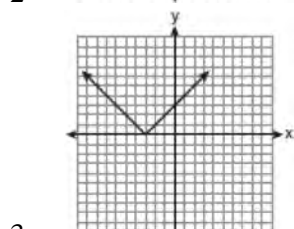
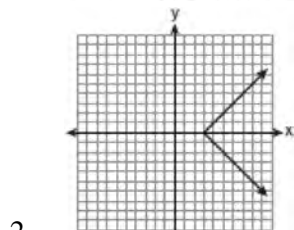
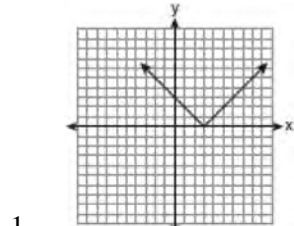

Which diagram could represent a graph of the equation $y = a|x|$ when $-1 < a < 0$?

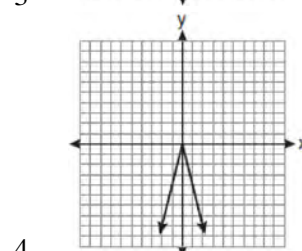
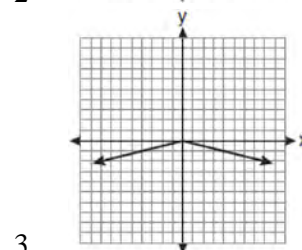
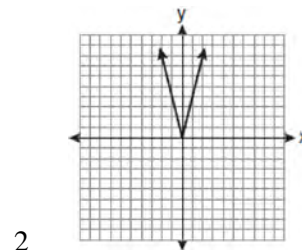
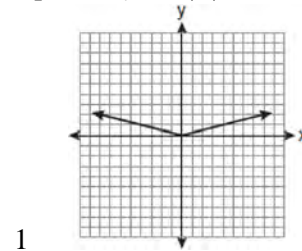

- 261 Graph and label the following equations on the set of axes below.

$$y = |x|$$

$$y = \left| \frac{1}{2}x \right|$$

Explain how *decreasing* the coefficient of x affects the graph of the equation $y = |x|$.

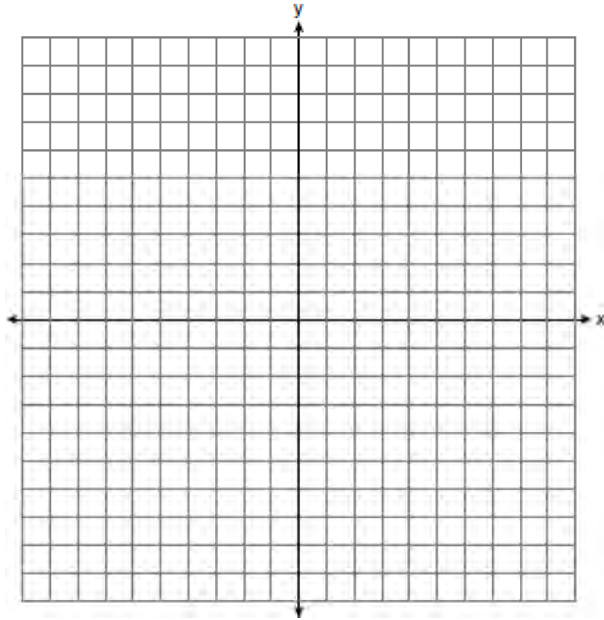

- 262 On the set of axes below, graph and label the equations $y = |x|$ and $y = 3|x|$ for the interval $-3 \leq x \leq 3$.

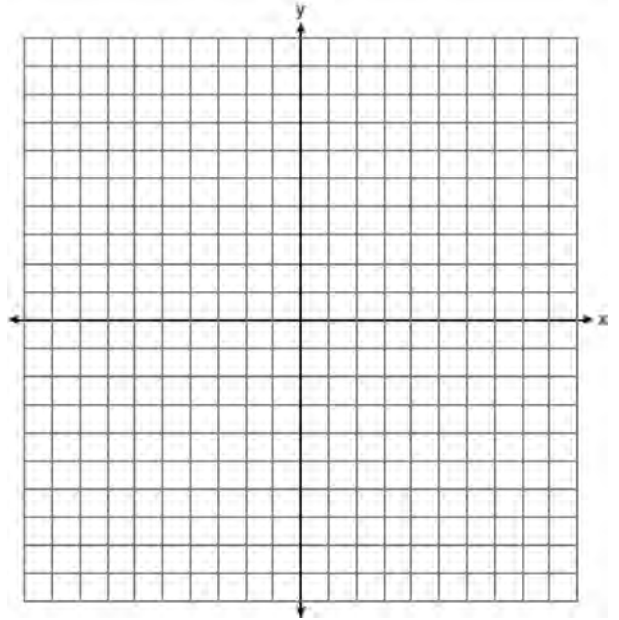

Explain how changing the coefficient of the absolute value from 1 to 3 affects the graph.

QUADRATICS

A.A.20: FACTORING POLYNOMIALS

- 263 What are the factors of the expression $x^2 + x - 20$?
- 1 $(x + 5)$ and $(x + 4)$
 - 2 $(x + 5)$ and $(x - 4)$
 - 3 $(x - 5)$ and $(x + 4)$
 - 4 $(x - 5)$ and $(x - 4)$
- 264 Factored completely, the expression $2x^2 + 10x - 12$ is equivalent to
- 1 $2(x - 6)(x + 1)$
 - 2 $2(x + 6)(x - 1)$
 - 3 $2(x + 2)(x + 3)$
 - 4 $2(x - 2)(x - 3)$

- 265 Factored completely, the expression $3x^2 - 3x - 18$ is equivalent to
- 1 $3(x^2 - x - 6)$
 - 2 $3(x - 3)(x + 2)$
 - 3 $(3x - 9)(x + 2)$
 - 4 $(3x + 6)(x - 3)$

A.A.19: FACTORING THE DIFFERENCE OF PERFECT SQUARES

- 266 The expression $x^2 - 16$ is equivalent to
- 1 $(x + 2)(x - 8)$
 - 2 $(x - 2)(x + 8)$
 - 3 $(x + 4)(x - 4)$
 - 4 $(x + 8)(x - 8)$
- 267 Which expression is equivalent to $64 - x^2$?
- 1 $(8 - x)(8 - x)$
 - 2 $(8 - x)(8 + x)$
 - 3 $(x - 8)(x - 8)$
 - 4 $(x - 8)(x + 8)$
- 268 Which expression is equivalent to $121 - x^2$?
- 1 $(x - 11)(x - 11)$
 - 2 $(x + 11)(x - 11)$
 - 3 $(11 - x)(11 + x)$
 - 4 $(11 - x)(11 - x)$
- 269 Factored, the expression $16x^2 - 25y^2$ is equivalent to
- 1 $(4x - 5y)(4x + 5y)$
 - 2 $(4x - 5y)(4x - 5y)$
 - 3 $(8x - 5y)(8x + 5y)$
 - 4 $(8x - 5y)(8x - 5y)$
- 270 The expression $9x^2 - 100$ is equivalent to
- 1 $(9x - 10)(x + 10)$
 - 2 $(3x - 10)(3x + 10)$
 - 3 $(3x - 100)(3x - 1)$
 - 4 $(9x - 100)(x + 1)$

- 271 Which expression is equivalent to $9x^2 - 16$?
- 1 $(3x + 4)(3x - 4)$
 - 2 $(3x - 4)(3x - 4)$
 - 3 $(3x + 8)(3x - 8)$
 - 4 $(3x - 8)(3x - 8)$

- 272 The expression $x^2 - 36y^2$ is equivalent to
- 1 $(x - 6y)(x - 6y)$
 - 2 $(x - 18y)(x - 18y)$
 - 3 $(x + 6y)(x - 6y)$
 - 4 $(x + 18y)(x - 18y)$

- 273 When $a^3 - 4a$ is factored completely, the result is
- 1 $(a - 2)(a + 2)$
 - 2 $a(a - 2)(a + 2)$
 - 3 $a^2(a - 4)$
 - 4 $a(a - 2)^2$

- 274 Which expression represents $36x^2 - 100y^6$ factored completely?
- 1 $2(9x + 25y^3)(9x - 25y^3)$
 - 2 $4(3x + 5y^3)(3x - 5y^3)$
 - 3 $(6x + 10y^3)(6x - 10y^3)$
 - 4 $(18x + 50y^3)(18x - 50y^3)$

- 275 If Ann correctly factors an expression that is the difference of two perfect squares, her factors could be
- 1 $(2x + y)(x - 2y)$
 - 2 $(2x + 3y)(2x - 3y)$
 - 3 $(x - 4)(x - 4)$
 - 4 $(2y - 5)(y - 5)$

- 276 Factor completely: $4x^3 - 36x$

A.A.27: SOLVING QUADRATICS BY FACTORING

- 277 The solution to the equation $x^2 - 6x = 0$ is
- 1 0, only
 - 2 6, only
 - 3 0 and 6
 - 4 $\pm\sqrt{6}$

A.A.28: ROOTS OF QUADRATICS

- 278 What are the roots of the equation $x^2 - 10x + 21 = 0$?
- 1 1 and 21
 - 2 -5 and -5
 - 3 3 and 7
 - 4 -3 and -7
- 279 What are the roots of the equation $x^2 - 7x + 6 = 0$?
- 1 1 and 7
 - 2 -1 and 7
 - 3 -1 and -6
 - 4 1 and 6
- 280 What are the roots of the equation $x^2 - 5x + 6 = 0$?
- 1 1 and -6
 - 2 2 and 3
 - 3 -1 and 6
 - 4 -2 and -3
- 281 The roots of the equation $3x^2 - 27x = 0$ are
- 1 0 and 9
 - 2 0 and -9
 - 3 0 and 3
 - 4 0 and -3

282 Find the roots of the equation $x^2 - x = 6$ algebraically.

283 Find the roots of the equation $x^2 = 30 - 13x$ algebraically.

284 Which equation has roots of -3 and 5?

- 1 $x^2 + 2x - 15 = 0$
- 2 $x^2 - 2x - 15 = 0$
- 3 $x^2 + 2x + 15 = 0$
- 4 $x^2 - 2x + 15 = 0$

A.G.5: GRAPHING QUADRATIC FUNCTIONS

285 Consider the graph of the equation $y = ax^2 + bx + c$, when $a \neq 0$. If a is multiplied by 3, what is true of the graph of the resulting parabola?

- 1 The vertex is 3 units above the vertex of the original parabola.
- 2 The new parabola is 3 units to the right of the original parabola.
- 3 The new parabola is wider than the original parabola.
- 4 The new parabola is narrower than the original parabola.

286 Melissa graphed the equation $y = x^2$ and Dave graphed the equation $y = -3x^2$ on the same coordinate grid. What is the relationship between the graphs that Melissa and Dave drew?

- 1 Dave's graph is wider and opens in the opposite direction from Melissa's graph.
- 2 Dave's graph is narrower and opens in the opposite direction from Melissa's graph.
- 3 Dave's graph is wider and is three units below Melissa's graph.
- 4 Dave's graph is narrower and is three units to the left of Melissa's graph.

287 The diagram below shows the graph of $y = -x^2 - c$.

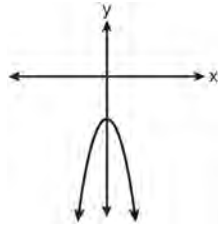

Which diagram shows the graph of $y = x^2 - c$?

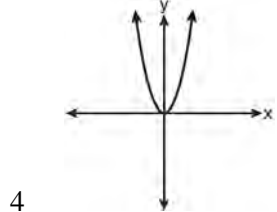
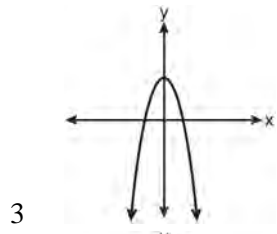
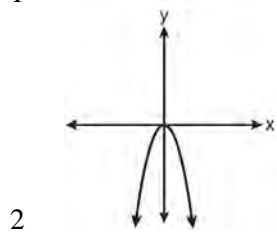
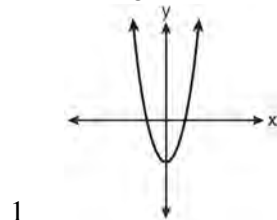

A.G.8: SOLVING QUADRATICS BY GRAPHING

288 The equation $y = x^2 + 3x - 18$ is graphed on the set of axes below.

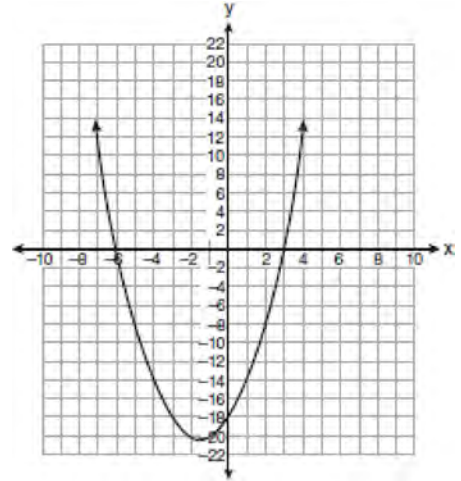

Based on this graph, what are the roots of the equation $x^2 + 3x - 18 = 0$?

- 1 -3 and 6
- 2 0 and -18
- 3 3 and -6
- 4 3 and -18

- 289 The equation $y = -x^2 - 2x + 8$ is graphed on the set of axes below.

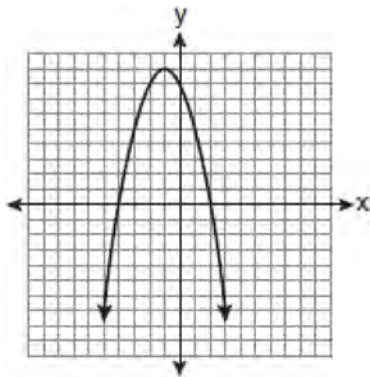

Based on this graph, what are the roots of the equation $-x^2 - 2x + 8 = 0$?

- 1 8 and 0
 - 2 2 and -4
 - 3 9 and -1
 - 4 4 and -2
- 290 A student correctly graphed the parabola shown below to solve a given quadratic equation.

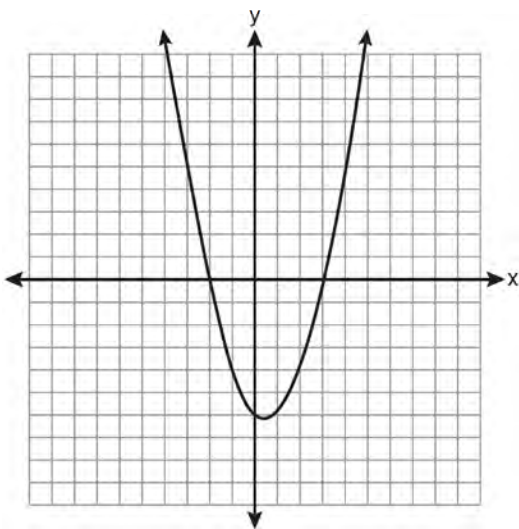

What are the roots of the quadratic equation associated with this graph?

- 1 -6 and 3
- 2 -6 and 0
- 3 -3 and 2
- 4 -2 and 3

- 291 Graph the equation $y = x^2 - 2x - 3$ on the accompanying set of axes. Using the graph, determine the roots of the equation $x^2 - 2x - 3 = 0$.

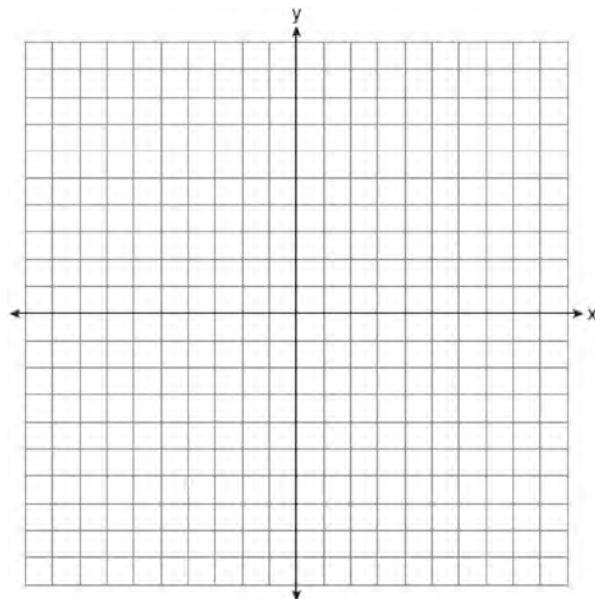

A.A.8: WRITING QUADRATICS

- 292 When 36 is subtracted from the square of a number, the result is five times the number. What is the positive solution?
- 1 9
 - 2 6
 - 3 3
 - 4 4
- 293 Byron is 3 years older than Doug. The product of their ages is 40. How old is Doug?
- 1 10
 - 2 8
 - 3 5
 - 4 4
- 294 Find three consecutive positive even integers such that the product of the second and third integers is twenty more than ten times the first integer. [Only an algebraic solution can receive full credit.]

A.A.8: GEOMETRIC APPLICATIONS OF QUADRATICS

- 295 A rectangle has an area of 24 square units. The width is 5 units less than the length. What is the length, in units, of the rectangle?
- 1 6
 - 2 8
 - 3 3
 - 4 19
- 296 The length of a rectangle is 3 inches more than its width. The area of the rectangle is 40 square inches. What is the length, in inches, of the rectangle?
- 1 5
 - 2 8
 - 3 8.5
 - 4 11.5
- 297 A contractor needs 54 square feet of brick to construct a rectangular walkway. The length of the walkway is 15 feet more than the width. Write an equation that could be used to determine the dimensions of the walkway. Solve this equation to find the length and width, in feet, of the walkway.

A.G.10: IDENTIFYING THE VERTEX OF A QUADRATIC GIVEN GRAPH

- 298 What are the vertex and the axis of symmetry of the parabola shown in the diagram below?

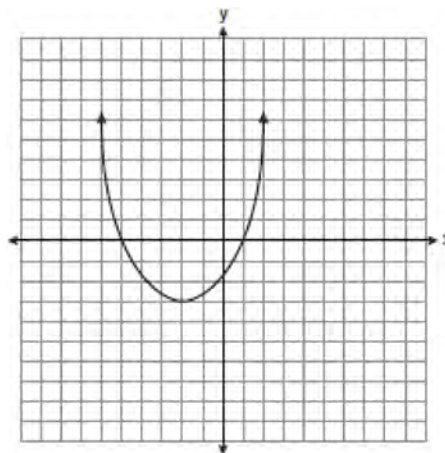

- 1 The vertex is $(-2, -3)$, and the axis of symmetry is $x = -2$.
- 2 The vertex is $(-2, -3)$, and the axis of symmetry is $y = -2$.
- 3 The vertex is $(-3, -2)$, and the axis of symmetry is $y = -2$.
- 4 The vertex is $(-3, -2)$, and the axis of symmetry is $x = -2$.

- 299 A swim team member performs a dive from a 14-foot-high springboard. The parabola below shows the path of her dive.

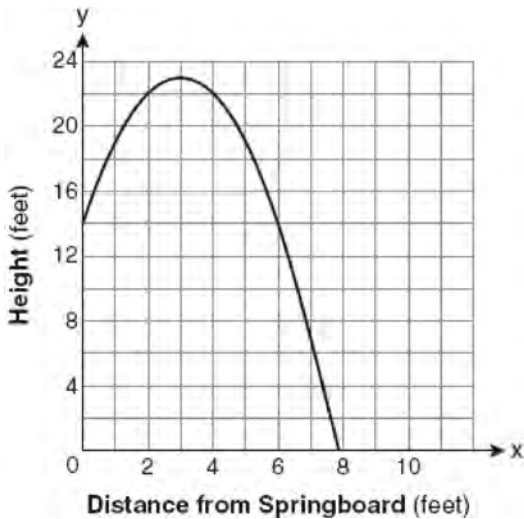

Which equation represents the axis of symmetry?

- 1 $x = 3$
 - 2 $y = 3$
 - 3 $x = 23$
 - 4 $y = 23$
- 300 Which equation represents the axis of symmetry of the graph of the parabola below?

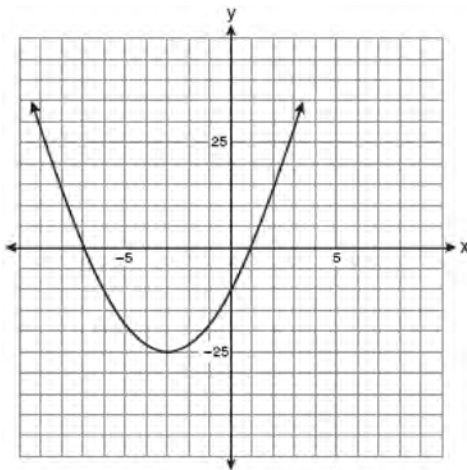

- 1 $y = -3$
- 2 $x = -3$
- 3 $y = -25$
- 4 $x = -25$

- 301 What is the equation of the axis of symmetry of the parabola shown in the diagram below?

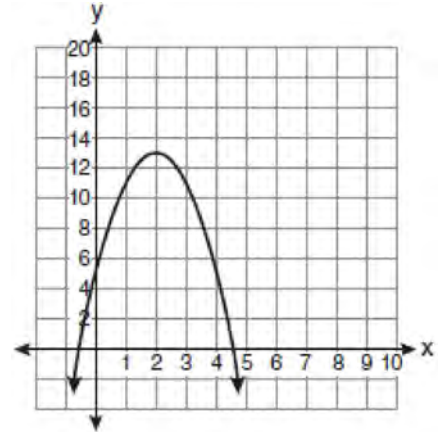

- 1 $x = -0.5$
- 2 $x = 2$
- 3 $x = 4.5$
- 4 $x = 13$

- 302 What are the vertex and axis of symmetry of the parabola shown in the diagram below?

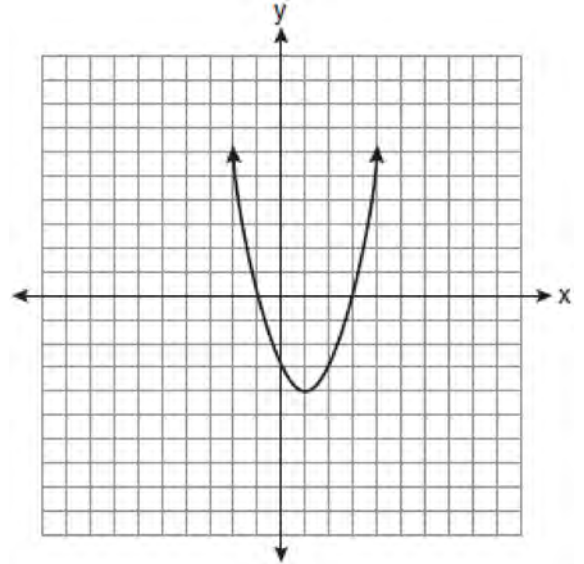

- 1 vertex: $(1, -4)$; axis of symmetry: $x = 1$
- 2 vertex: $(1, -4)$; axis of symmetry: $x = -4$
- 3 vertex: $(-4, 1)$; axis of symmetry: $x = 1$
- 4 vertex: $(-4, 1)$; axis of symmetry: $x = -4$

- 303 State the equation of the axis of symmetry and the coordinates of the vertex of the parabola graphed below.

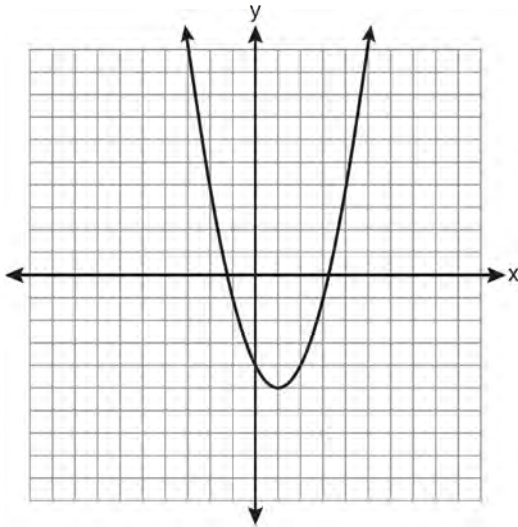

- 304 What are the vertex and the axis of symmetry of the parabola shown in the graph below?

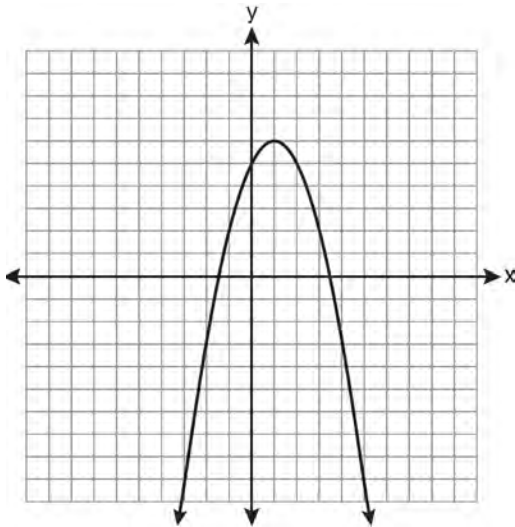

- 1 vertex: (1, 6); axis of symmetry: $y = 1$
- 2 vertex: (1, 6); axis of symmetry: $x = 1$
- 3 vertex: (6, 1); axis of symmetry: $y = 1$
- 4 vertex: (6, 1); axis of symmetry: $x = 1$

A.A.41: IDENTIFYING THE VERTEX OF A QUADRATIC GIVEN EQUATION

- 305 What is an equation of the axis of symmetry of the parabola represented by $y = -x^2 + 6x - 4$?

- 1 $x = 3$
- 2 $y = 3$
- 3 $x = 6$
- 4 $y = 6$

- 306 The equation of the axis of symmetry of the graph of $y = 2x^2 - 3x + 7$ is

- 1 $x = \frac{3}{4}$
- 2 $y = \frac{3}{4}$
- 3 $x = \frac{3}{2}$
- 4 $y = \frac{3}{2}$

- 307 The height, y , of a ball tossed into the air can be represented by the equation $y = -x^2 + 10x + 3$, where x is the elapsed time. What is the equation of the axis of symmetry of this parabola?

- 1 $y = 5$
- 2 $y = -5$
- 3 $x = 5$
- 4 $x = -5$

- 308 What are the vertex and axis of symmetry of the parabola $y = x^2 - 16x + 63$?

- 1 vertex: (8, -1); axis of symmetry: $x = 8$
- 2 vertex: (8, 1); axis of symmetry: $x = 8$
- 3 vertex: (-8, -1); axis of symmetry: $x = -8$
- 4 vertex: (-8, 1); axis of symmetry: $x = -8$

- 309 Find algebraically the equation of the axis of symmetry and the coordinates of the vertex of the parabola whose equation is $y = -2x^2 - 8x + 3$.

SYSTEMS

A.A.10: SOLVING LINEAR SYSTEMS

- 310 What is the value of the y -coordinate of the solution to the system of equations $x + 2y = 9$ and $x - y = 3$?

- 1 6
- 2 2
- 3 3
- 4 5

- 311 What is the value of the y -coordinate of the solution to the system of equations $x - 2y = 1$ and $x + 4y = 7$?

- 1 1
- 2 -1
- 3 3
- 4 4

- 312 What is the value of the y -coordinate of the solution to the system of equations $2x + y = 8$ and $x - 3y = -3$?

- 1 -2
- 2 2
- 3 3
- 4 -3

- 313 The equations $5x + 2y = 48$ and $3x + 2y = 32$ represent the money collected from school concert ticket sales during two class periods. If x represents the cost for each adult ticket and y represents the cost for each student ticket, what is the cost for each adult ticket?

- 1 \$20
- 2 \$10
- 3 \$8
- 4 \$4

- 314 What is the solution of the system of equations $2x - 5y = 11$ and $-2x + 3y = -9$?

- 1 $(-3, -1)$
- 2 $(-1, 3)$
- 3 $(3, -1)$
- 4 $(3, 1)$

- 315 What is the solution of the system of equations $c + 3d = 8$ and $c = 4d - 6$?

- 1 $c = -14, d = -2$
- 2 $c = -2, d = 2$
- 3 $c = 2, d = 2$
- 4 $c = 14, d = -2$

- 316 Solve the following system of equations algebraically:

$$3x + 2y = 4$$

$$4x + 3y = 7$$

[Only an algebraic solution can receive full credit.]

A.G.7: SOLVING LINEAR SYSTEMS

- 317 On the grid below, solve the system of equations graphically for x and y .

$$4x - 2y = 10$$

$$y = -2x - 1$$

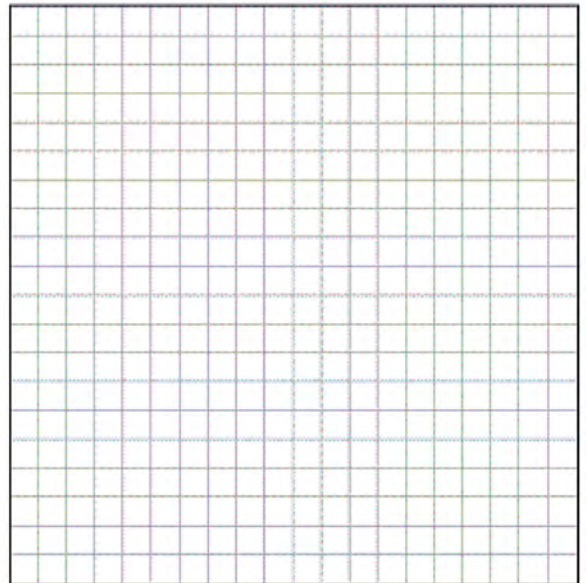

- 318 On the set of axes below, solve the following system of equations graphically. State the coordinates of the solution.

$$y = 4x - 1$$

$$2x + y = 5$$

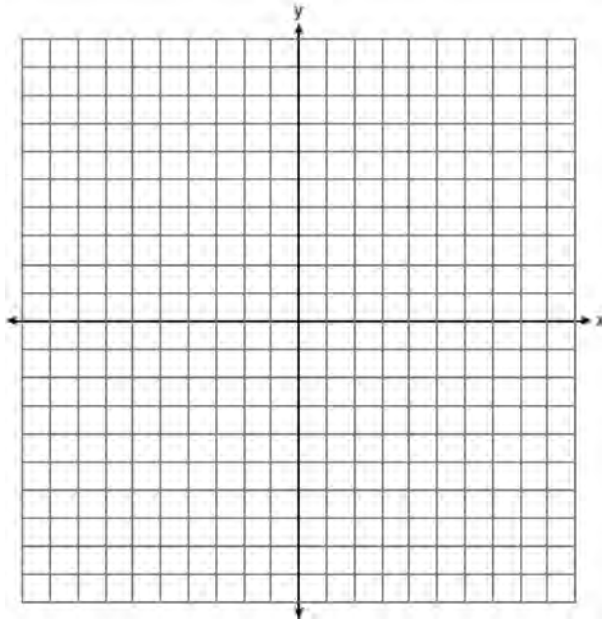

A.A.7: WRITING LINEAR SYSTEMS

- 319 The sum of two numbers is 47, and their difference is 15. What is the larger number?
- 1 16
 - 2 31
 - 3 32
 - 4 36
- 320 Michael is 25 years younger than his father. The sum of their ages is 53. What is Michael's age?
- 1 14
 - 2 25
 - 3 28
 - 4 39
- 321 Pam is playing with red and black marbles. The number of red marbles she has is three more than twice the number of black marbles she has. She has 42 marbles in all. How many red marbles does Pam have?
- 1 13
 - 2 15
 - 3 29
 - 4 33
- 322 Ben has four more than twice as many CDs as Jake. If they have a total of 31 CDs, how many CDs does Jake have?
- 1 9
 - 2 13
 - 3 14
 - 4 22
- 323 Sam and Odel have been selling frozen pizzas for a class fundraiser. Sam has sold half as many pizzas as Odel. Together they have sold a total of 126 pizzas. How many pizzas did Sam sell?
- 1 21
 - 2 42
 - 3 63
 - 4 84
- 324 Julia went to the movies and bought one jumbo popcorn and two chocolate chip cookies for \$5.00. Marvin went to the same movie and bought one jumbo popcorn and four chocolate chip cookies for \$6.00. How much does one chocolate chip cookie cost?
- 1 \$0.50
 - 2 \$0.75
 - 3 \$1.00
 - 4 \$2.00
- 325 Jack bought 3 slices of cheese pizza and 4 slices of mushroom pizza for a total cost of \$12.50. Grace bought 3 slices of cheese pizza and 2 slices of mushroom pizza for a total cost of \$8.50. What is the cost of one slice of mushroom pizza?
- 1 \$1.50
 - 2 \$2.00
 - 3 \$3.00
 - 4 \$3.50

326 Josh and Mae work at a concession stand. They each earn \$8 per hour. Josh worked three hours more than Mae. If Josh and Mae earned a total of \$120, how many hours did Josh work?

- 1 6
- 2 9
- 3 12
- 4 15

327 At Genesee High School, the sophomore class has 60 more students than the freshman class. The junior class has 50 fewer students than twice the students in the freshman class. The senior class is three times as large as the freshman class. If there are a total of 1,424 students at Genesee High School, how many students are in the freshman class?

- 1 202
- 2 205
- 3 235
- 4 236

328 The cost of 3 markers and 2 pencils is \$1.80. The cost of 4 markers and 6 pencils is \$2.90. What is the cost of *each* item? Include appropriate units in your answer.

A.A.40: SYSTEMS OF LINEAR INEQUALITIES

329 Which ordered pair is in the solution set of the system of linear inequalities graphed below?

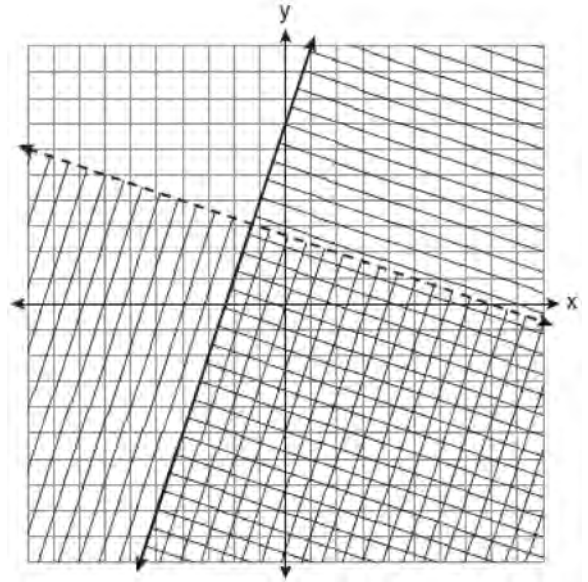

- 1 (1, -4)
- 2 (-5, 7)
- 3 (5, 3)
- 4 (-7, -2)

- 330 Which ordered pair is in the solution set of the system of inequalities shown in the graph below?

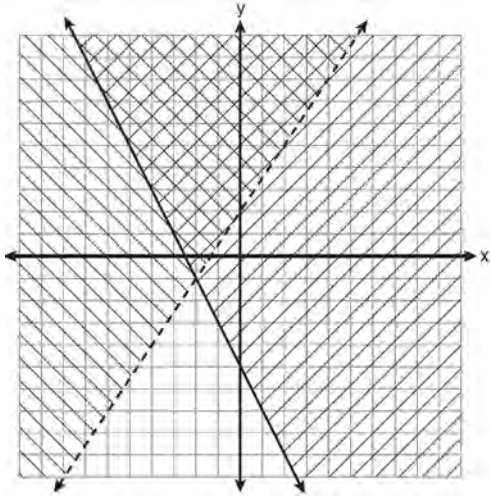

- 1 $(-2, -1)$
 - 2 $(-2, 2)$
 - 3 $(-2, -4)$
 - 4 $(2, -2)$
- 331 Which ordered pair is in the solution set of the following system of inequalities?

$$y < \frac{1}{2}x + 4$$

$$y \geq -x + 1$$

- 1 $(-5, 3)$
 - 2 $(0, 4)$
 - 3 $(3, -5)$
 - 4 $(4, 0)$
- 332 Which ordered pair is in the solution set of the following system of linear inequalities?

$$y < 2x + 2$$

$$y \geq -x - 1$$

- 1 $(0, 3)$
- 2 $(2, 0)$
- 3 $(-1, 0)$
- 4 $(-1, -4)$

A.G.7: SYSTEMS OF LINEAR INEQUALITIES

- 333 On the set of axes below, solve the following system of inequalities graphically.

$$y < 2x + 1$$

$$y \geq -\frac{1}{3}x + 4$$

State the coordinates of a point in the solution set.

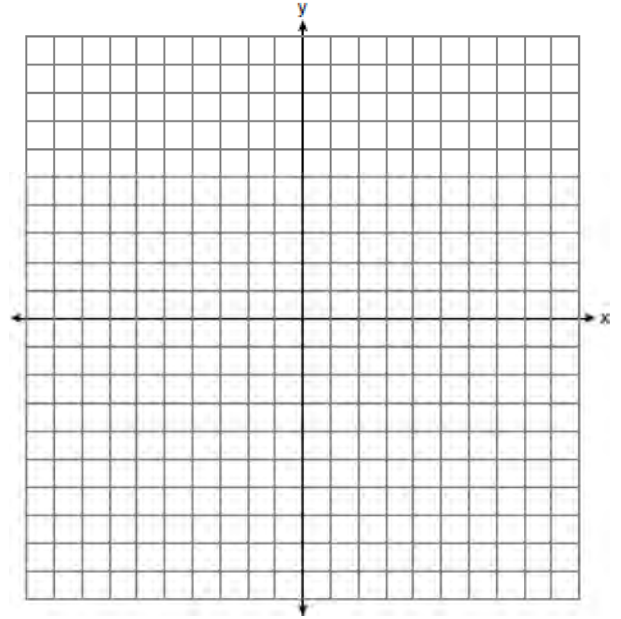

- 334 Graph the following systems of inequalities on the set of axes shown below and label the solution set S :

$$y > -x + 2$$

$$y \leq \frac{2}{3}x + 5$$

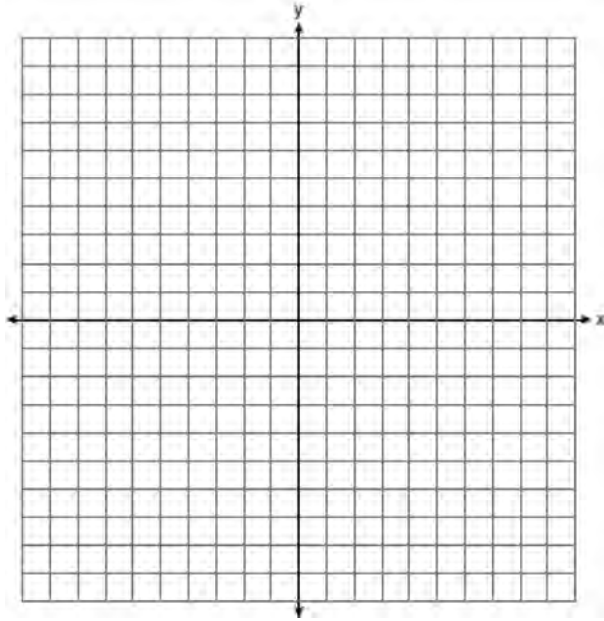

- 335 On the set of axes below, graph the following system of inequalities and state the coordinates of a point in the solution set.

$$2x - y \geq 6$$

$$x > 2$$

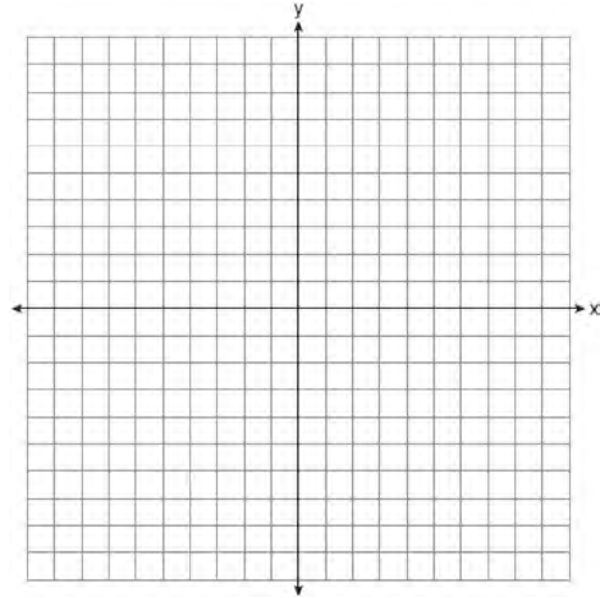

- 336 Solve the following system of inequalities graphically on the set of axes below.

$$3x + y < 7$$

$$y \geq \frac{2}{3}x - 4$$

State the coordinates of a point in the solution set.

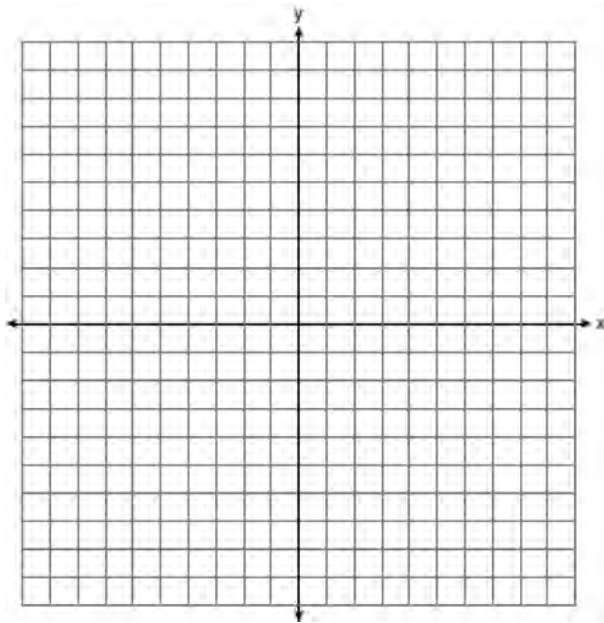

A.A.11: QUADRATIC-LINEAR SYSTEMS

- 337 Which ordered pair is a solution to the system of equations $y = x$ and $y = x^2 - 2$?
- 1 $(-2, -2)$
 - 2 $(-1, 1)$
 - 3 $(0, 0)$
 - 4 $(2, 2)$
- 338 Which ordered pair is in the solution set of the system of equations $y = -x + 1$ and $y = x^2 + 5x + 6$?
- 1 $(-5, -1)$
 - 2 $(-5, 6)$
 - 3 $(5, -4)$
 - 4 $(5, 2)$

- 339 Which ordered pair is a solution of the system of equations $y = x^2 - x - 20$ and $y = 3x - 15$?

- 1 $(-5, -30)$
- 2 $(-1, -18)$
- 3 $(0, 5)$
- 4 $(5, -1)$

- 340 Which ordered pair is a solution to the system of equations $y = x + 3$ and $y = x^2 - x$?

- 1 $(6, 9)$
- 2 $(3, 6)$
- 3 $(3, -1)$
- 4 $(2, 5)$

A.G.9: QUADRATIC-LINEAR SYSTEMS

- 341 Which ordered pair is a solution of the system of equations shown in the graph below?

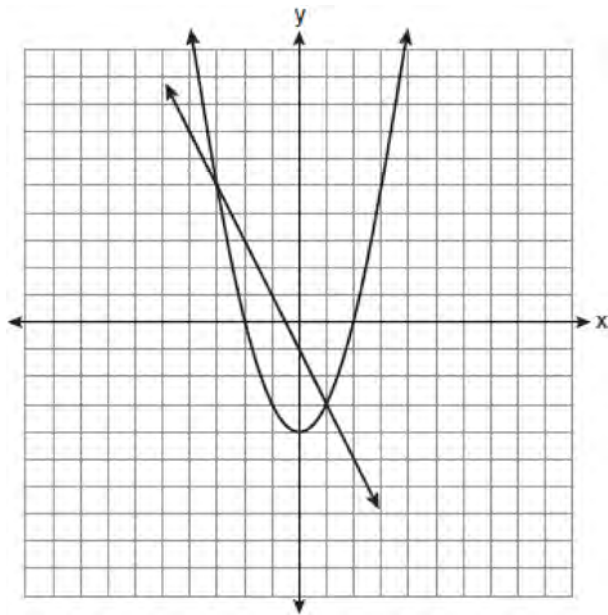

- 1 $(-3, 1)$
- 2 $(-3, 5)$
- 3 $(0, -1)$
- 4 $(0, -4)$

Integrated Algebra Regents Exam Questions by Performance Indicator: Topic

www.jmap.org

342 Two equations were graphed on the set of axes below.

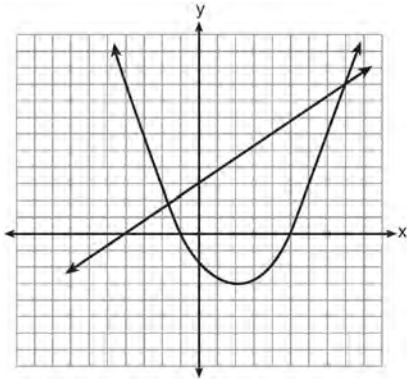

Which point is a solution of the system of equations shown on the graph?

- 1 (8, 9)
- 2 (5, 0)
- 3 (0, 3)
- 4 (2, -3)

343 Which graph can be used to find the solution of the following system of equations?

$$y = x^2 + 2x + 3$$

$$2y - 2x = 10$$

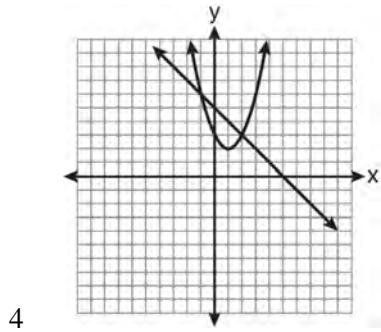
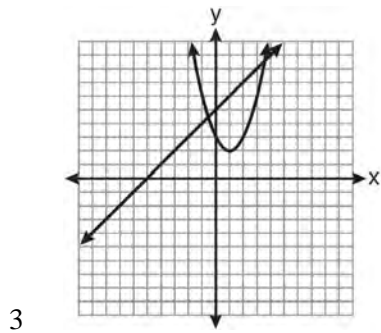
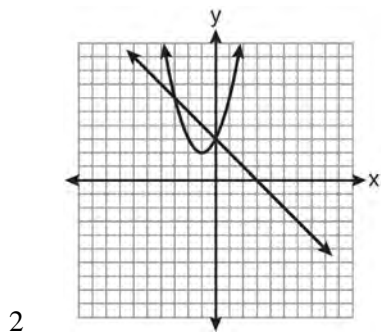
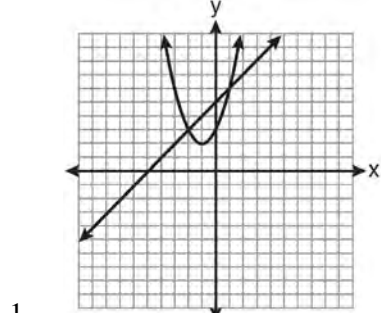

344 Which graph could be used to find the solution of the system of equations $y = 2x + 6$ and $y = x^2 + 4x + 3$?

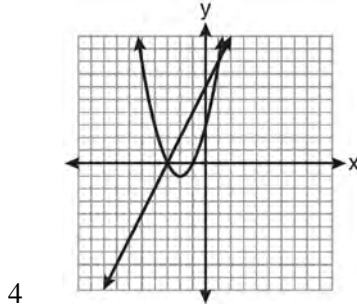
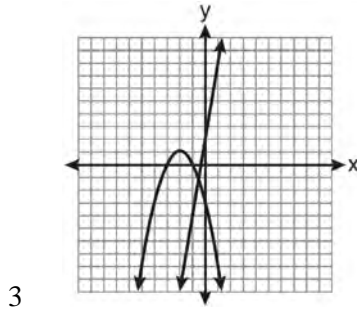
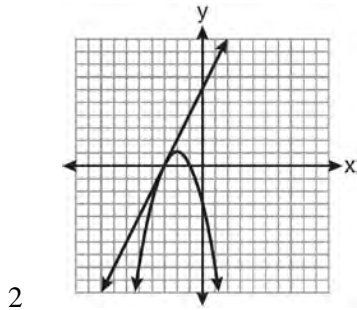
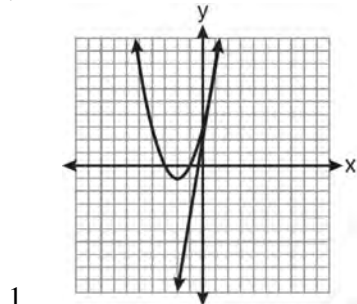

345 On the set of axes below, solve the following system of equations graphically and state the coordinates of all points in the solution set.

$$y = x^2 + 4x - 5$$

$$y = x - 1$$

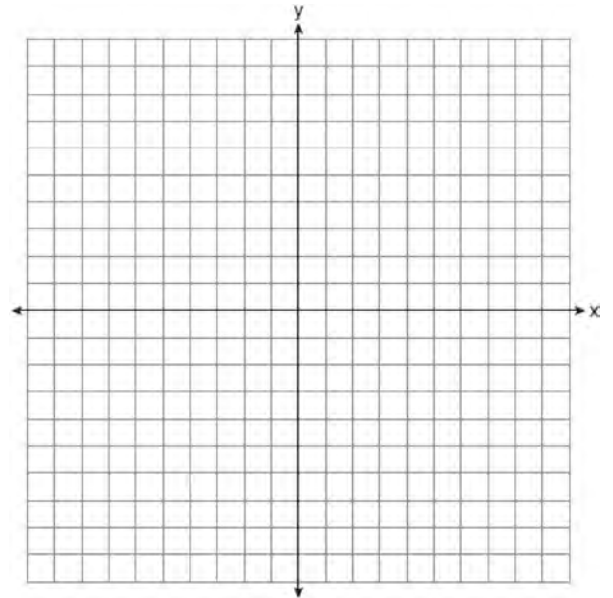

- 346 On the set of axes below, solve the following system of equations graphically for all values of x and y .

$$y = -x^2 - 4x + 12$$

$$y = -2x + 4$$

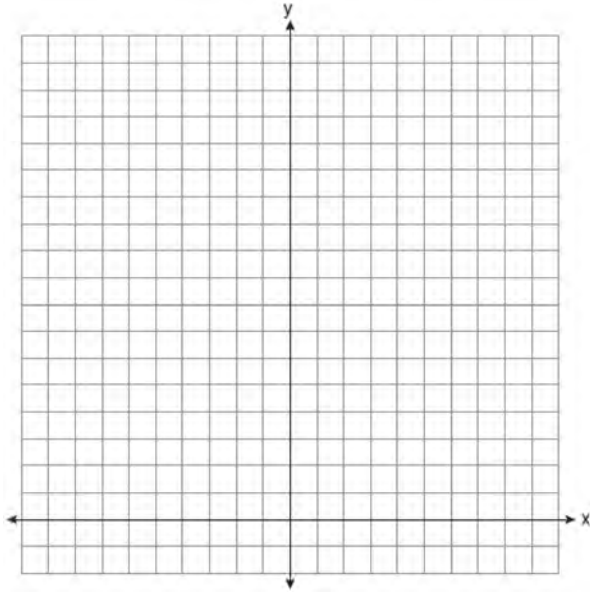

- 347 Solve the following systems of equations graphically, on the set of axes below, and state the coordinates of the point(s) in the solution set.

$$y = x^2 - 6x + 5$$

$$2x + y = 5$$

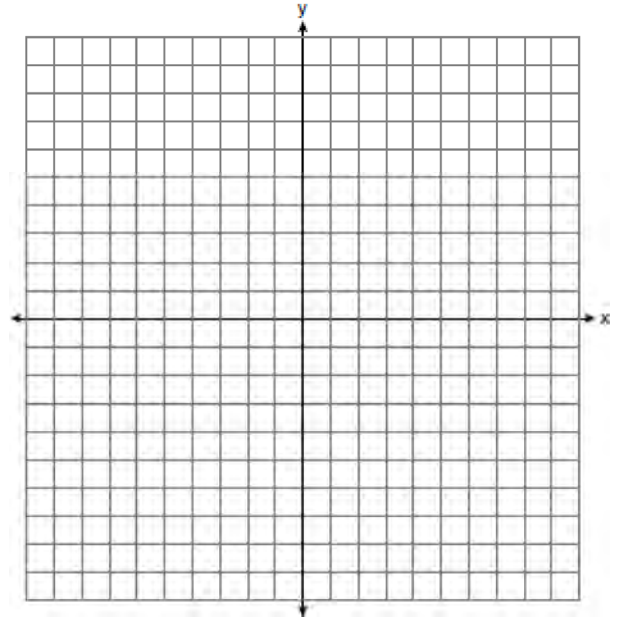

- 348 On the set of axes below, solve the following system of equations graphically for all values of x and y .

$$y = x^2 - 6x + 1$$

$$y + 2x = 6$$

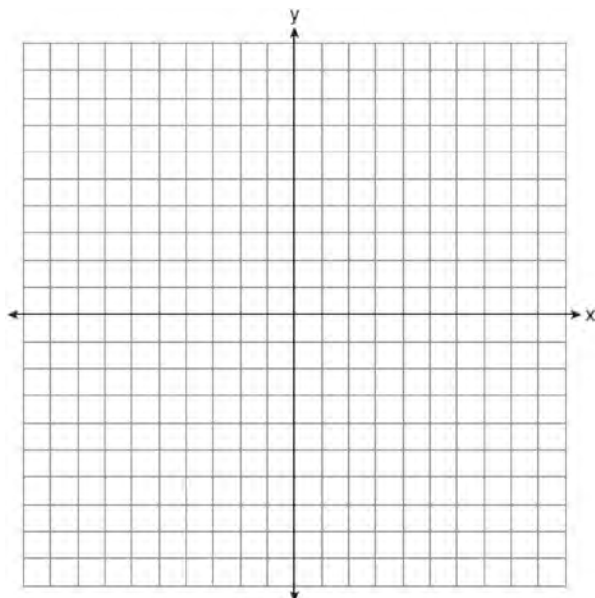

- 349 On the set of axes below, solve the following system of equations graphically and state the coordinates of *all* points in the solution set.

$$y = -x^2 + 6x - 3$$

$$x + y = 7$$

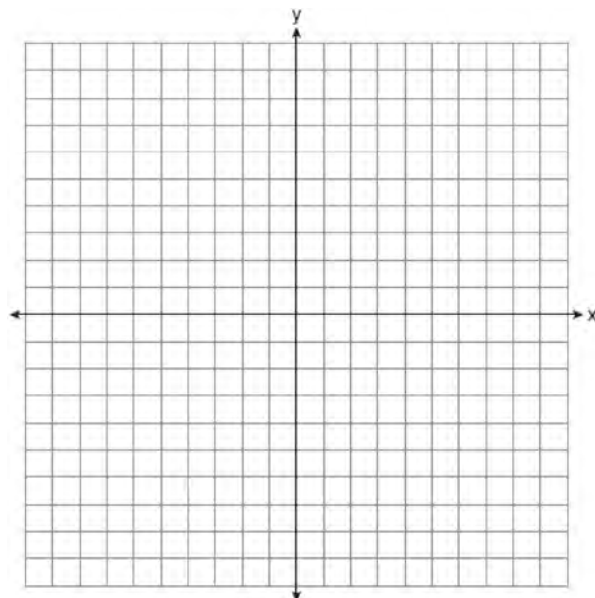

POWERS

A.A.13: ADDITION AND SUBTRACTION OF MONOMIALS

- 350 Which expression is equivalent to $-3x(x - 4) - 2x(x + 3)$?

- 1 $-x^2 - 1$
- 2 $-x^2 + 18x$
- 3 $-5x^2 - 6x$
- 4 $-5x^2 + 6x$

A.A.13: ADDITION AND SUBTRACTION OF POLYNOMIALS

- 351 The sum of $4x^3 + 6x^2 + 2x - 3$ and $3x^3 + 3x^2 - 5x - 5$ is
- 1 $7x^3 + 3x^2 - 3x - 8$
 - 2 $7x^3 + 3x^2 + 7x + 2$
 - 3 $7x^3 + 9x^2 - 3x - 8$
 - 4 $7x^6 + 9x^4 - 3x^2 - 8$
- 352 What is the sum of $-3x^2 - 7x + 9$ and $-5x^2 + 6x - 4$?
- 1 $-8x^2 - x + 5$
 - 2 $-8x^4 - x + 5$
 - 3 $-8x^2 - 13x + 13$
 - 4 $-8x^4 - 13x^2 + 13$
- 353 When $3g^2 - 4g + 2$ is subtracted from $7g^2 + 5g - 1$, the difference is
- 1 $-4g^2 - 9g + 3$
 - 2 $4g^2 + g + 1$
 - 3 $4g^2 + 9g - 3$
 - 4 $10g^2 + g + 1$
- 354 When $4x^2 + 7x - 5$ is subtracted from $9x^2 - 2x + 3$, the result is
- 1 $5x^2 + 5x - 2$
 - 2 $5x^2 - 9x + 8$
 - 3 $-5x^2 + 5x - 2$
 - 4 $-5x^2 + 9x - 8$
- 355 What is the result when $2x^2 + 3xy - 6$ is subtracted from $x^2 - 7xy + 2$?
- 1 $-x^2 - 10xy + 8$
 - 2 $x^2 + 10xy - 8$
 - 3 $-x^2 - 4xy - 4$
 - 4 $x^2 - 4xy - 4$

- 356 When $5x + 4y$ is subtracted from $5x - 4y$, the difference is
- 1 0
 - 2 $10x$
 - 3 $8y$
 - 4 $-8y$

A.A.13: MULTIPLICATION OF POLYNOMIALS

- 357 What is the product of $-3x^2y$ and $(5xy^2 + xy)$?
- 1 $-15x^3y^3 - 3x^3y^2$
 - 2 $-15x^3y^3 - 3x^3y$
 - 3 $-15x^2y^2 - 3x^2y$
 - 4 $-15x^3y^3 + xy$

A.A.14: DIVISION OF POLYNOMIALS

- 358 Which expression represents $\frac{12x^3 - 6x^2 + 2x}{2x}$ in simplest form?
- 1 $6x^2 - 3x$
 - 2 $10x^2 - 4x$
 - 3 $6x^2 - 3x + 1$
 - 4 $10x^2 - 4x + 1$

- 359 Express in simplest form: $\frac{45a^4b^3 - 90a^3b}{15a^2b}$

A.A.12: MULTIPLICATION OF POWERS

- 360 Which expression is equivalent to $3^3 \cdot 3^4$?
- 1 9^{12}
 - 2 9^7
 - 3 3^{12}
 - 4 3^7

361 Which expression represents $(3x^2y^4)(4xy^2)$ in simplest form?

- 1 $12x^2y^8$
- 2 $12x^2y^6$
- 3 $12x^3y^8$
- 4 $12x^3y^6$

A.A.12: DIVISION OF POWERS

362 What is half of 2^6 ?

- 1 1^3
- 2 1^6
- 3 2^3
- 4 2^5

363 Which expression represents $\frac{27x^{18}y^5}{9x^6y}$ in simplest form?

- 1 $3x^{12}y^4$
- 2 $3x^3y^5$
- 3 $18x^{12}y^4$
- 4 $18x^3y^5$

364 Which expression represents $\frac{-14a^2c^8}{7a^3c^2}$ in simplest form?

- 1 $-2ac^4$
- 2 $-2ac^6$
- 3 $\frac{-2c^4}{a}$
- 4 $\frac{-2c^6}{a}$

365 The expression $\frac{12w^9y^3}{-3w^3y^3}$ is equivalent to

- 1 $-4w^6$
- 2 $-4w^3y$
- 3 $9w^6$
- 4 $9w^3y$

366 Which expression represents $\frac{(2x^3)(8x^5)}{4x^6}$ in simplest form?

- 1 x^2
- 2 x^9
- 3 $4x^2$
- 4 $4x^9$

367 Simplify: $\frac{27k^5m^8}{(4k^3)(9m^2)}$

A.A.12: POWERS OF POWERS

368 Which expression is equivalent to $(3x^2)^3$?

- 1 $9x^5$
- 2 $9x^6$
- 3 $27x^5$
- 4 $27x^6$

369 The expression $\frac{(10w^3)^2}{5w}$ is equivalent to

- 1 $2w^5$
- 2 $2w^8$
- 3 $20w^5$
- 4 $20w^8$

370 The expression $\frac{(4x^3)^2}{2x}$ is equivalent to

- 1 $4x^4$
- 2 $4x^5$
- 3 $8x^4$
- 4 $8x^5$

A.N.4: OPERATIONS WITH SCIENTIFIC NOTATION

- 371 What is the product of 8.4×10^8 and 4.2×10^3 written in scientific notation?
- 1 2.0×10^5
 - 2 12.6×10^{11}
 - 3 35.28×10^{11}
 - 4 3.528×10^{12}
- 372 What is the product of 12 and 4.2×10^6 expressed in scientific notation?
- 1 50.4×10^6
 - 2 50.4×10^7
 - 3 5.04×10^6
 - 4 5.04×10^7
- 373 What is the product of (6×10^3) , (4.6×10^5) , and (2×10^{-2}) expressed in scientific notation?
- 1 55.2×10^6
 - 2 5.52×10^7
 - 3 55.2×10^7
 - 4 5.52×10^{10}
- 374 What is the quotient of 8.05×10^6 and 3.5×10^2 ?
- 1 2.3×10^3
 - 2 2.3×10^4
 - 3 2.3×10^8
 - 4 2.3×10^{12}
- 375 The quotient of (9.2×10^6) and (2.3×10^2) expressed in scientific notation is
- 1 4,000
 - 2 40,000
 - 3 4×10^3
 - 4 4×10^4

A.A.9: EXPONENTIAL FUNCTIONS

- 376 Mr. Smith invested \$2,500 in a savings account that earns 3% interest compounded annually. He made no additional deposits or withdrawals. Which expression can be used to determine the number of dollars in this account at the end of 4 years?
- 1 $2500(1 + 0.03)^4$
 - 2 $2500(1 + 0.3)^4$
 - 3 $2500(1 + 0.04)^3$
 - 4 $2500(1 + 0.4)^3$
- 377 Kathy plans to purchase a car that depreciates (loses value) at a rate of 14% per year. The initial cost of the car is \$21,000. Which equation represents the value, v , of the car after 3 years?
- 1 $v = 21,000(0.14)^3$
 - 2 $v = 21,000(0.86)^3$
 - 3 $v = 21,000(1.14)^3$
 - 4 $v = 21,000(0.86)(3)$
- 378 The New York Volleyball Association invited 64 teams to compete in a tournament. After each round, half of the teams were eliminated. Which equation represents the number of teams, t , that remained in the tournament after r rounds?
- 1 $t = 64(r)^{0.5}$
 - 2 $t = 64(-0.5)^r$
 - 3 $t = 64(1.5)^r$
 - 4 $t = 64(0.5)^r$

- 379 In a science fiction novel, the main character found a mysterious rock that decreased in size each day. The table below shows the part of the rock that remained at noon on successive days.

Day	Fractional Part of the Rock Remaining
1	1
2	$\frac{1}{2}$
3	$\frac{1}{4}$
4	$\frac{1}{8}$

Which fractional part of the rock will remain at noon on day 7?

- 1 $\frac{1}{128}$
 - 2 $\frac{1}{64}$
 - 3 $\frac{1}{14}$
 - 4 $\frac{1}{12}$
- 380 Cassandra bought an antique dresser for \$500. If the value of her dresser increases 6% annually, what will be the value of Cassandra's dresser at the end of 3 years to the *nearest dollar*?
- 1 \$415
 - 2 \$590
 - 3 \$596
 - 4 \$770
- 381 The current student population of the Brentwood Student Center is 2,000. The enrollment at the center increases at a rate of 4% each year. To the *nearest whole number*, what will the student population be closest to in 3 years'?
- 1 2,240
 - 2 2,250
 - 3 5,488
 - 4 6,240
- 382 The value, y , of a \$15,000 investment over x years is represented by the equation $y = 15000(1.2)^{\frac{x}{3}}$. What is the profit (interest) on a 6-year investment?
- 1 \$6,600
 - 2 \$10,799
 - 3 \$21,600
 - 4 \$25,799
- 383 Daniel's Print Shop purchased a new printer for \$35,000. Each year it depreciates (loses value) at a rate of 5%. What will its approximate value be at the end of the fourth year?
- 1 \$33,250.00
 - 2 \$30,008.13
 - 3 \$28,507.72
 - 4 \$27,082.33
- 384 The value of a car purchased for \$20,000 decreases at a rate of 12% per year. What will be the value of the car after 3 years?
- 1 \$12,800.00
 - 2 \$13,629.44
 - 3 \$17,600.00
 - 4 \$28,098.56
- 385 The Booster Club raised \$30,000 for a sports fund. No more money will be placed into the fund. Each year the fund will decrease by 5%. Determine the amount of money, to the *nearest cent*, that will be left in the sports fund after 4 years.
- 386 A bank is advertising that new customers can open a savings account with a $3\frac{3}{4}\%$ interest rate compounded annually. Robert invests \$5,000 in an account at this rate. If he makes no additional deposits or withdrawals on his account, find the amount of money he will have, to the *nearest cent*, after three years.

A.G.4: GRAPHING EXPONENTIAL FUNCTIONS

- 387 On the set of axes below, draw the graph of $y = 2^x$ over the interval $-1 \leq x \leq 3$. Will this graph ever intersect the x -axis? Justify your answer.

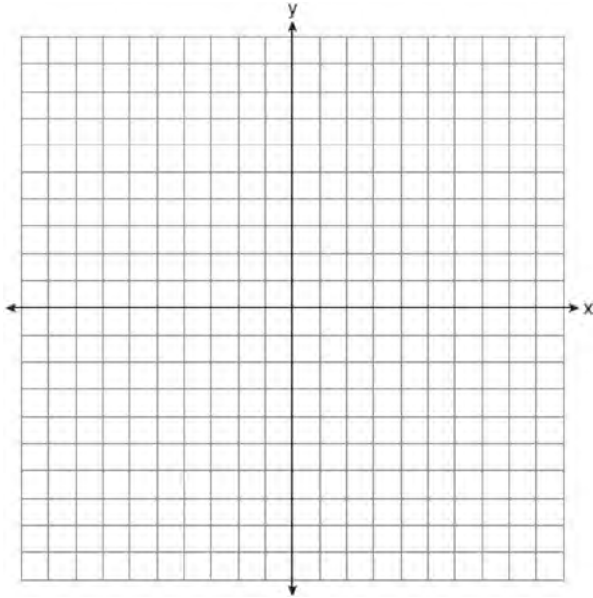

RADICALS

A.N.2: SIMPLIFYING RADICALS

- 388 What is $\sqrt{32}$ expressed in simplest radical form?
 1 $16\sqrt{2}$
 2 $4\sqrt{2}$
 3 $4\sqrt{8}$
 4 $2\sqrt{8}$
- 389 What is $\sqrt{72}$ expressed in simplest radical form?
 1 $2\sqrt{18}$
 2 $3\sqrt{8}$
 3 $6\sqrt{2}$
 4 $8\sqrt{3}$

- 390 What is $2\sqrt{45}$ expressed in simplest radical form?
 1 $3\sqrt{5}$
 2 $5\sqrt{5}$
 3 $6\sqrt{5}$
 4 $18\sqrt{5}$

- 391 What is $3\sqrt{250}$ expressed in simplest radical form?
 1 $5\sqrt{10}$
 2 $8\sqrt{10}$
 3 $15\sqrt{10}$
 4 $75\sqrt{10}$

- 392 What is $\frac{\sqrt{32}}{4}$ expressed in simplest radical form?
 1 $\sqrt{2}$
 2 $4\sqrt{2}$
 3 $\sqrt{8}$
 4 $\frac{\sqrt{8}}{2}$

- 393 When $5\sqrt{20}$ is written in simplest radical form, the result is $k\sqrt{5}$. What is the value of k ?
 1 20
 2 10
 3 7
 4 4

- 394 Express $5\sqrt{72}$ in simplest radical form.

- 395 Express $-3\sqrt{48}$ in simplest radical form.

Integrated Algebra Regents Exam Questions by Performance Indicator: Topic

A.N.3: OPERATIONS WITH RADICALS

396 What is $3\sqrt{2} + \sqrt{8}$ expressed in simplest radical form?

- 1 $3\sqrt{10}$
- 2 $3\sqrt{16}$
- 3 $5\sqrt{2}$
- 4 $7\sqrt{2}$

397 The expression $\sqrt{72} - 3\sqrt{2}$ written in simplest radical form is

- 1 $5\sqrt{2}$
- 2 $3\sqrt{6}$
- 3 $3\sqrt{2}$
- 4 $\sqrt{6}$

398 The expression $6\sqrt{50} + 6\sqrt{2}$ written in simplest radical form is

- 1 $6\sqrt{52}$
- 2 $12\sqrt{52}$
- 3 $17\sqrt{2}$
- 4 $36\sqrt{2}$

399 Express $\frac{16\sqrt{21}}{2\sqrt{7}} - 5\sqrt{12}$ in simplest radical form.

400 Express the product of $3\sqrt{20}(2\sqrt{5} - 7)$ in simplest radical form.

RATIONALS

A.A.16: RATIONAL EXPRESSIONS

401 The expression $\frac{9x^4 - 27x^6}{3x^3}$ is equivalent to

- 1 $3x(1 - 3x)$
- 2 $3x(1 - 3x^2)$
- 3 $3x(1 - 9x^5)$
- 4 $9x^3(1 - x)$

402 Which expression represents $\frac{2x^2 - 12x}{x - 6}$ in simplest form?

- 1 0
- 2 $2x$
- 3 $4x$
- 4 $2x + 2$

403 Which expression represents $\frac{25x - 125}{x^2 - 25}$ in simplest form?

- 1 $\frac{5}{x}$
- 2 $\frac{-5}{x}$
- 3 $\frac{25}{x - 5}$
- 4 $\frac{25}{x + 5}$

404 Which expression represents $\frac{x^2 - 2x - 15}{x^2 + 3x}$ in simplest form?

- 1 -5
- 2 $\frac{x - 5}{x}$
- 3 $\frac{-2x - 5}{x}$
- 4 $\frac{-2x - 15}{3x}$

405 Which expression represents $\frac{x^2 - x - 6}{x^2 - 5x + 6}$ in

simplest form?

- 1 $\frac{x+2}{x-2}$
- 2 $\frac{-x-6}{-5x+6}$
- 3 $\frac{1}{5}$
- 4 -1

406 Express in simplest form: $\frac{x^2 - 1}{x^2 + 3x + 2}$

407 The area of a rectangle is represented by $x^2 - 5x - 24$. If the width of the rectangle is represented by $x - 8$, express the length of the rectangle as a binomial.

A.A.15: UNDEFINED RATIONALS

408 Which value of x makes the expression $\frac{x+4}{x-3}$ undefined?

- 1 -4
- 2 -3
- 3 3
- 4 0

409 Which value of n makes the expression $\frac{5n}{2n-1}$ undefined?

- 1 1
- 2 0
- 3 $-\frac{1}{2}$
- 4 $\frac{1}{2}$

410 For which value of x is $\frac{x-3}{x^2-4}$ undefined?

- 1 -2
- 2 0
- 3 3
- 4 4

411 The function $y = \frac{x}{x^2 - 9}$ is undefined when the value of x is

- 1 0 or 3
- 2 3 or -3
- 3 3 , only
- 4 -3 , only

412 The algebraic expression $\frac{x-2}{x^2-9}$ is undefined when x is

- 1 0
- 2 2
- 3 3
- 4 9

413 Which value of x makes the expression $\frac{x^2-9}{x^2+7x+10}$ undefined?

- 1 -5
- 2 2
- 3 3
- 4 -3

414 For which set of values of x is the algebraic expression $\frac{x^2-16}{x^2-4x-12}$ undefined?

- 1 $\{-6, 2\}$
- 2 $\{-4, 3\}$
- 3 $\{-4, 4\}$
- 4 $\{-2, 6\}$

415 For which values of x is the fraction $\frac{x^2 + x - 6}{x^2 + 5x - 6}$

undefined?

- 1 1 and -6
- 2 2 and -3
- 3 3 and -2
- 4 6 and -1

A.A.18: MULTIPLICATION AND DIVISION OF RATIONALS

416 What is the product of $\frac{x^2 - 1}{x + 1}$ and $\frac{x + 3}{3x - 3}$ expressed

in simplest form?

- 1 x
- 2 $\frac{x}{3}$
- 3 $x + 3$
- 4 $\frac{x + 3}{3}$

417 What is the product of $\frac{4x}{x - 1}$ and $\frac{x^2 - 1}{3x + 3}$ expressed

in simplest form?

- 1 $\frac{4x}{3}$
- 2 $\frac{4x^2}{3}$
- 3 $\frac{4x^2}{3(x + 1)}$
- 4 $\frac{4(x + 1)}{3}$

418 What is the quotient of $\frac{x}{x + 4}$ divided by $\frac{2x}{x^2 - 16}$?

- 1 $\frac{2}{x - 4}$
- 2 $\frac{2x^2}{x - 4}$
- 3 $\frac{2x^2}{x^2 - 16}$
- 4 $\frac{x - 4}{2}$

419 Perform the indicated operation and simplify:

$$\frac{3x + 6}{4x + 12} \div \frac{x^2 - 4}{x + 3}$$

420 Express in simplest form: $\frac{2x^2 - 8x - 42}{6x^2} \div \frac{x^2 - 9}{x^2 - 3x}$

421 Express in simplest form:

$$\frac{x^2 + 9x + 14}{x^2 - 49} \div \frac{3x + 6}{x^2 + x - 56}$$

A.A.17: ADDITION AND SUBTRACTION OF RATIONALS

422 What is $\frac{2 + x}{5x} - \frac{x - 2}{5x}$ expressed in simplest form?

- 1 0
- 2 $\frac{2}{5}$
- 3 $\frac{4}{5x}$
- 4 $\frac{2x + 4}{5x}$

423 What is the sum of $\frac{d}{2}$ and $\frac{2d}{3}$ expressed in simplest form?

- 1 $\frac{3d}{5}$
- 2 $\frac{3d}{6}$
- 3 $\frac{7d}{5}$
- 4 $\frac{7d}{6}$

424 What is $\frac{6}{5x} - \frac{2}{3x}$ in simplest form?

- 1 $\frac{8}{15x^2}$
- 2 $\frac{8}{15x}$
- 3 $\frac{4}{15x}$
- 4 $\frac{4}{2x}$

425 What is $\frac{6}{4a} - \frac{2}{3a}$ expressed in simplest form?

- 1 $\frac{4}{a}$
- 2 $\frac{5}{6a}$
- 3 $\frac{8}{7a}$
- 4 $\frac{10}{12a}$

426 What is the sum of $\frac{3}{2x}$ and $\frac{4}{3x}$ expressed in simplest form?

- 1 $\frac{12}{6x^2}$
- 2 $\frac{17}{6x}$
- 3 $\frac{7}{5x}$
- 4 $\frac{17}{12x}$

427 What is the sum of $\frac{3}{2x}$ and $\frac{7}{4x}$?

- 1 $\frac{21}{8x^2}$
- 2 $\frac{13}{4x}$
- 3 $\frac{10}{6x}$
- 4 $\frac{13}{8x}$

428 What is $\frac{7}{12x} - \frac{y}{6x^2}$ expressed in simplest form?

- 1 $\frac{7-y}{6x}$
- 2 $\frac{7-y}{12x-6x^2}$
- 3 $-\frac{7y}{12x^2}$
- 4 $\frac{7x-2y}{12x^2}$

429 What is the sum of $\frac{3x^2}{x-2}$ and $\frac{x^2}{x-2}$?

- 1 $\frac{3x^4}{(x-2)^2}$
- 2 $\frac{3x^4}{x-2}$
- 3 $\frac{4x^2}{(x-2)^2}$
- 4 $\frac{4x^2}{x-2}$

430 What is the sum of $\frac{-x+7}{2x+4}$ and $\frac{2x+5}{2x+4}$?

- 1 $\frac{x+12}{2x+4}$
- 2 $\frac{3x+12}{2x+4}$
- 3 $\frac{x+12}{4x+8}$
- 4 $\frac{3x+12}{4x+8}$

- 431 What is the sum of $\frac{2y}{y+5}$ and $\frac{10}{y+5}$ expressed in simplest form?
- 1 1
 - 2 2
 - 3 $\frac{12y}{y+5}$
 - 4 $\frac{2y+10}{y+5}$

A.A.26: SOLVING RATIONALS

- 432 What is the solution of $\frac{k+4}{2} = \frac{k+9}{3}$?
- 1 1
 - 2 5
 - 3 6
 - 4 14
- 433 Which value of x is the solution of $\frac{2x-3}{x-4} = \frac{2}{3}$?
- 1 $-\frac{1}{4}$
 - 2 $\frac{1}{4}$
 - 3 -4
 - 4 4

- 434 Which value of x is a solution of $\frac{5}{x} = \frac{x+13}{6}$?
- 1 -2
 - 2 -3
 - 3 -10
 - 4 -15

- 435 What is the solution set of $\frac{x+2}{x-2} = \frac{-3}{x}$?
- 1 $\{-2, 3\}$
 - 2 $\{-3, -2\}$
 - 3 $\{-1, 6\}$
 - 4 $\{-6, 1\}$

- 436 What is the value of x in the equation $\frac{2}{x} - 3 = \frac{26}{x}$?
- 1 -8
 - 2 $-\frac{1}{8}$
 - 3 $\frac{1}{8}$
 - 4 8

- 437 Solve algebraically for x : $\frac{x+2}{6} = \frac{3}{x-1}$

- 438 Solve for x : $\frac{x+1}{x} = \frac{-7}{x-12}$

- 439 Solve algebraically for x : $\frac{3}{4} = \frac{-(x+11)}{4x} + \frac{1}{2x}$

FUNCTIONS

A.G.4: FAMILIES OF FUNCTIONS

- 440 Which type of graph is shown in the diagram below?

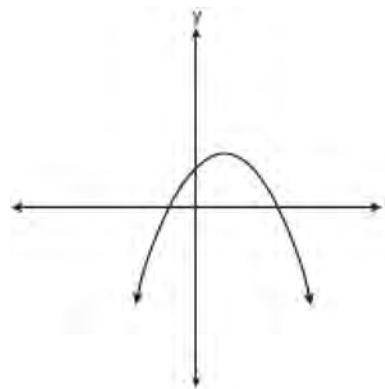

- 1 absolute value
- 2 exponential
- 3 linear
- 4 quadratic

441 Which graph represents a linear function?

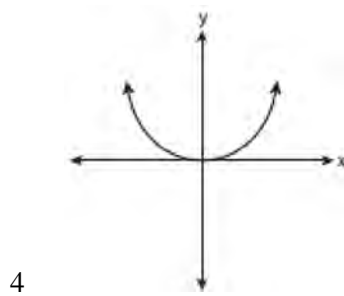
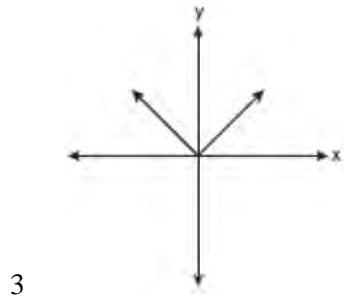
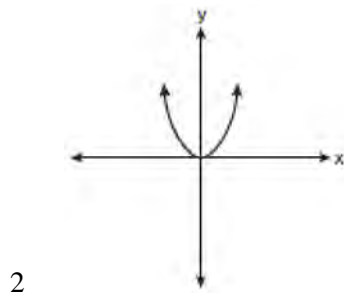
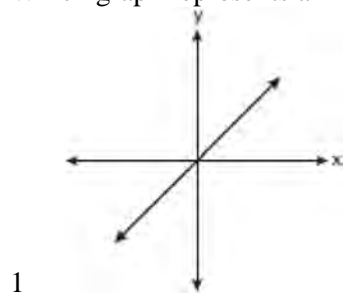

442 Which graph represents an exponential equation?

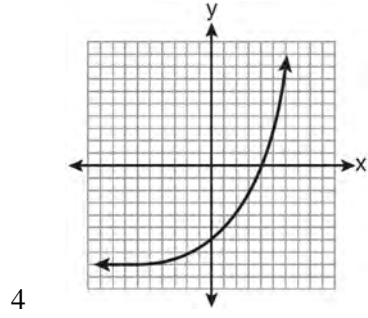
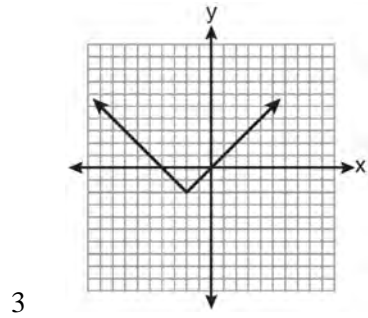
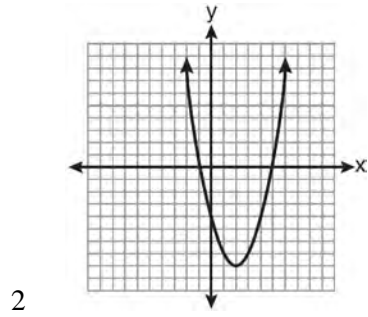
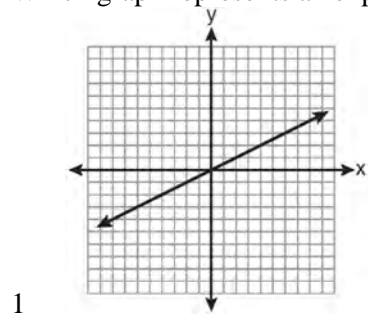

443 Which type of function is represented by the graph shown below?

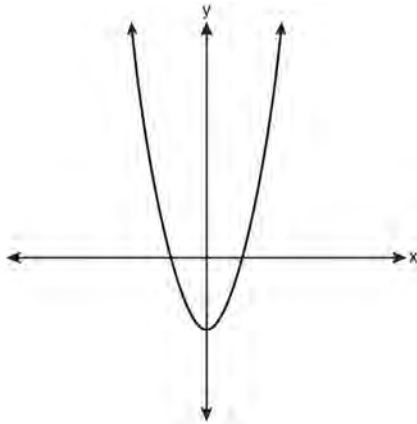

- 1 absolute value
- 2 exponential
- 3 linear
- 4 quadratic

444 Antwaan leaves a cup of hot chocolate on the counter in his kitchen. Which graph is the best representation of the change in temperature of his hot chocolate over time?

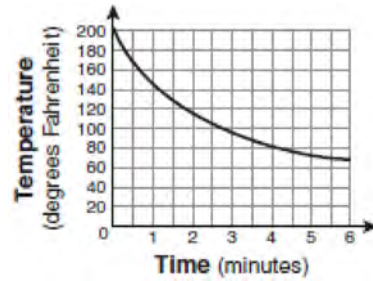

1

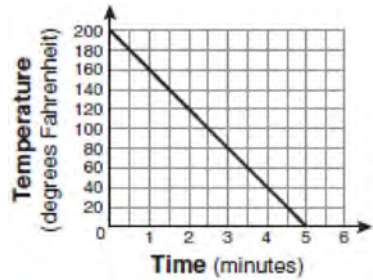

2

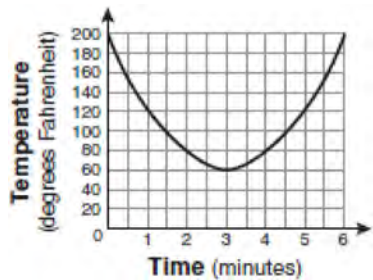

3

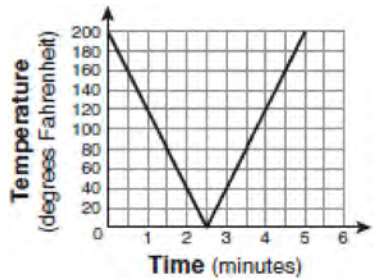

4

445 Which equation represents a quadratic function?

- 1 $y = x + 2$
- 2 $y = |x + 2|$
- 3 $y = x^2$
- 4 $y = 2^x$

A.G.4: IDENTIFYING THE EQUATION OF A GRAPH

446 Which equation is represented by the graph below?

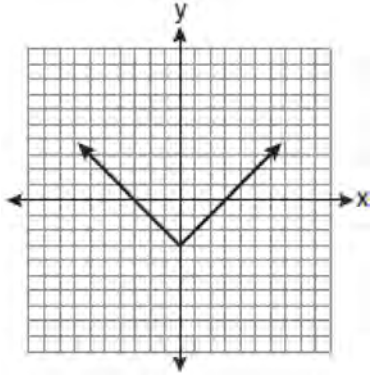

- 1 $y = x^2 - 3$
- 2 $y = (x - 3)^2$
- 3 $y = |x| - 3$
- 4 $y = |x - 3|$

A.G.3: DEFINING FUNCTIONS

447 Which graph represents a function?

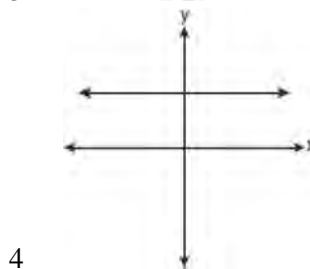
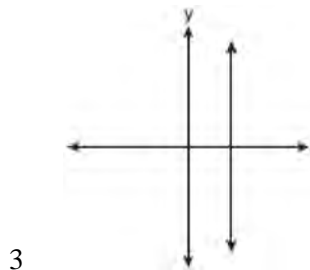
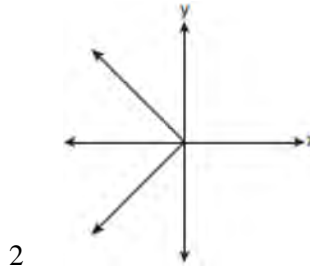
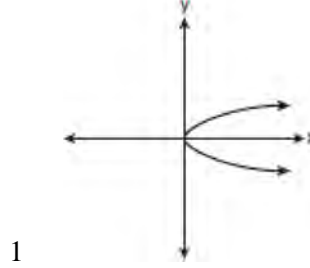

448 Which graph represents a function?

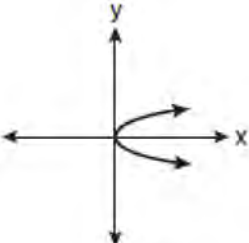
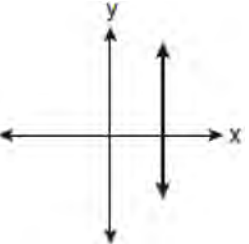
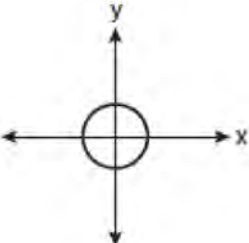
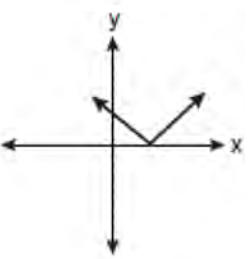
- 1 
- 2 
- 3 
- 4 

449 Which graph represents a function?

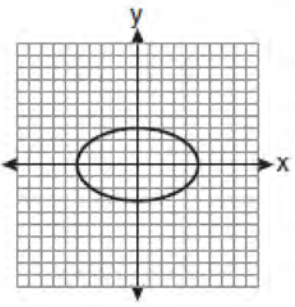
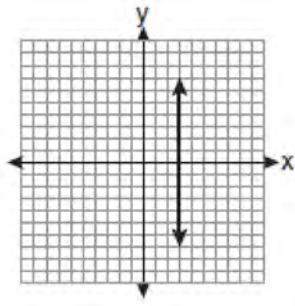
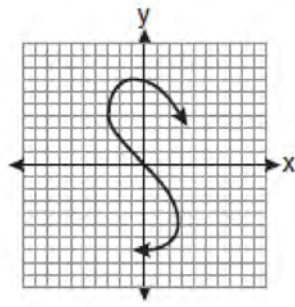
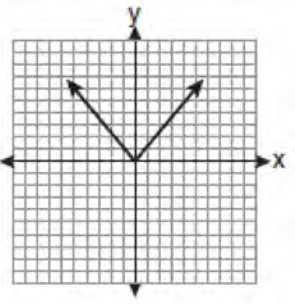
- 1 
- 2 
- 3 
- 4 

450 Which graph does *not* represent a function?

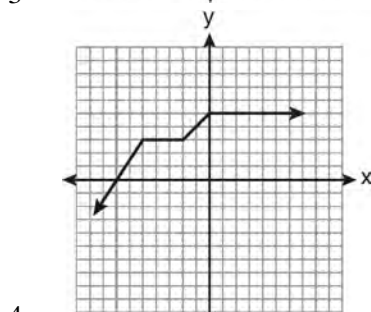
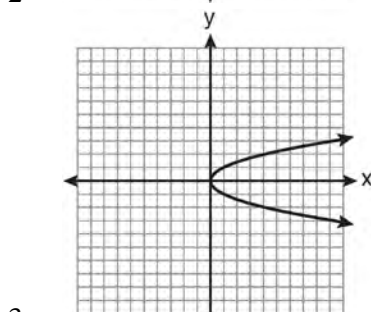
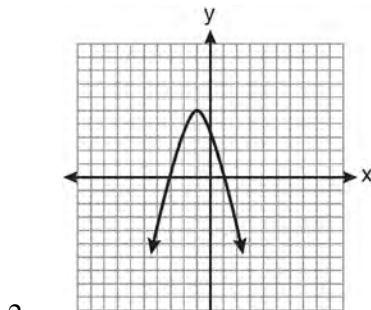
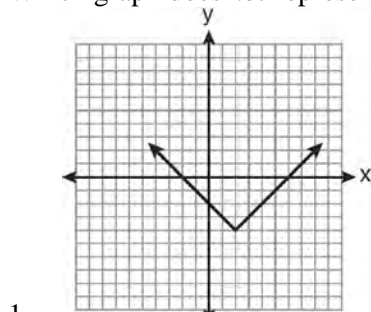

451 Which statement is true about the relation shown on the graph below?

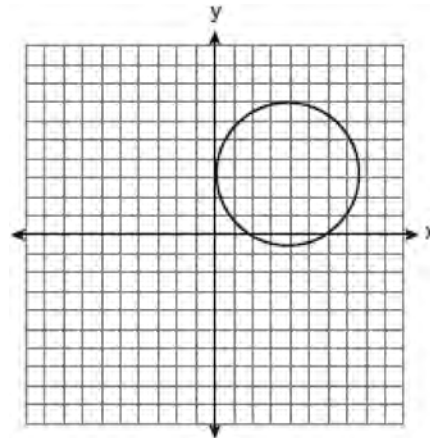

- 1 It is a function because there exists one x -coordinate for each y -coordinate.
- 2 It is a function because there exists one y -coordinate for each x -coordinate.
- 3 It is *not* a function because there are multiple y -values for a given x -value.
- 4 It is *not* a function because there are multiple x -values for a given y -value.

452 Which relation is *not* a function?

- 1 $\{(1, 5), (2, 6), (3, 6), (4, 7)\}$
- 2 $\{(4, 7), (2, 1), (-3, 6), (3, 4)\}$
- 3 $\{(-1, 6), (1, 3), (2, 5), (1, 7)\}$
- 4 $\{(-1, 2), (0, 5), (5, 0), (2, -1)\}$

453 Which relation represents a function?

- 1 $\{(0, 3), (2, 4), (0, 6)\}$
- 2 $\{(-7, 5), (-7, 1), (-10, 3), (-4, 3)\}$
- 3 $\{(2, 0), (6, 2), (6, -2)\}$
- 4 $\{(-6, 5), (-3, 2), (1, 2), (6, 5)\}$

454 Which relation is a function?

- 1 $\left\{\left(\frac{3}{4}, 0\right), (0, 1), \left(\frac{3}{4}, 2\right)\right\}$
- 2 $\left\{(-2, 2), \left(-\frac{1}{2}, 1\right), (-2, 4)\right\}$
- 3 $\{(-1, 4), (0, 5), (0, 4)\}$
- 4 $\{(2, 1), (4, 3), (6, 5)\}$

- 455 Which set of ordered pairs represents a function?
- 1 $\{(0,4), (2,4), (2,5)\}$
 - 2 $\{(6,0), (5,0), (4,0)\}$
 - 3 $\{(4,1), (6,2), (6,3), (5,0)\}$
 - 4 $\{(0,4), (1,4), (0,5), (1,5)\}$

TRIANGLES

A.A.45: PYTHAGOREAN THEOREM

- 456 Don placed a ladder against the side of his house as shown in the diagram below.

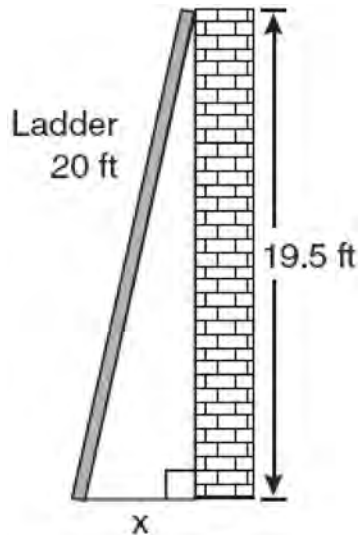

Which equation could be used to find the distance, x , from the foot of the ladder to the base of the house?

- 1 $x = 20 - 19.5$
- 2 $x = 20^2 - 19.5^2$
- 3 $x = \sqrt{20^2 - 19.5^2}$
- 4 $x = \sqrt{20^2 + 19.5^2}$

- 457 Tanya runs diagonally across a rectangular field that has a length of 40 yards and a width of 30 yards, as shown in the diagram below.

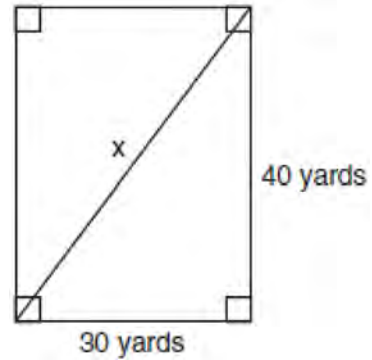

What is the length of the diagonal, in yards, that Tanya runs?

- 1 50
- 2 60
- 3 70
- 4 80

- 458 Nancy's rectangular garden is represented in the diagram below.

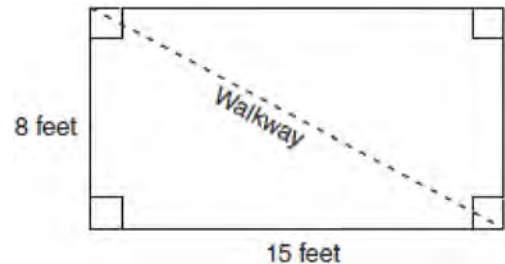

If a diagonal walkway crosses her garden, what is its length, in feet?

- 1 17
- 2 22
- 3 $\sqrt{161}$
- 4 $\sqrt{529}$

- 459 What is the value of x , in inches, in the right triangle below?

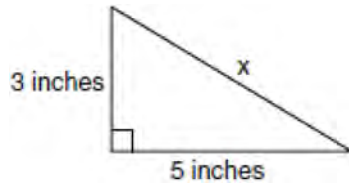

- 1 $\sqrt{15}$
 - 2 8
 - 3 $\sqrt{34}$
 - 4 4
- 460 The end of a dog's leash is attached to the top of a 5-foot-tall fence post, as shown in the diagram below. The dog is 7 feet away from the base of the fence post.

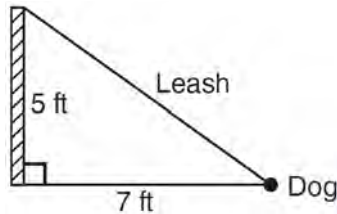

How long is the leash, to the *nearest tenth of a foot*?

- 1 4.9
 - 2 8.6
 - 3 9.0
 - 4 12.0
- 461 The legs of an isosceles right triangle each measure 10 inches. What is the length of the hypotenuse of this triangle, to the *nearest tenth of an inch*?
- 1 6.3
 - 2 7.1
 - 3 14.1
 - 4 17.1

- 462 The rectangle shown below has a diagonal of 18.4 cm and a width of 7 cm.

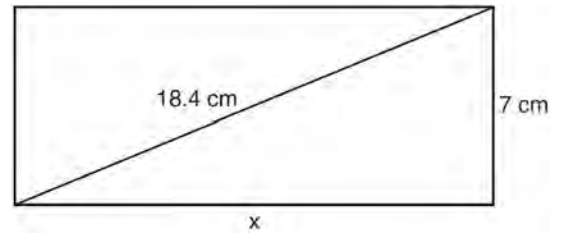

To the *nearest centimeter*, what is the length, x , of the rectangle?

- 1 11
 - 2 17
 - 3 20
 - 4 25
- 463 Campsite A and campsite B are located directly opposite each other on the shores of Lake Omega, as shown in the diagram below. The two campsites form a right triangle with Sam's position, S . The distance from campsite B to Sam's position is 1,300 yards, and campsite A is 1,700 yards from his position.

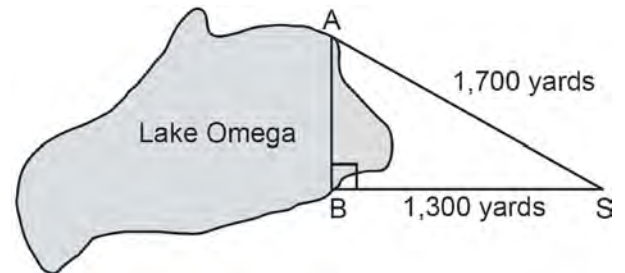

What is the distance from campsite A to campsite B , to the *nearest yard*?

- 1 1,095
- 2 1,096
- 3 2,140
- 4 2,141

- 464 The length of the hypotenuse of a right triangle is 34 inches and the length of one of its legs is 16 inches. What is the length, in inches, of the other leg of this right triangle?
- 16
 - 18
 - 25
 - 30

TRIGONOMETRY

A.A.42: TRIGONOMETRIC RATIOS

- 465 The diagram below shows right triangle UPC .

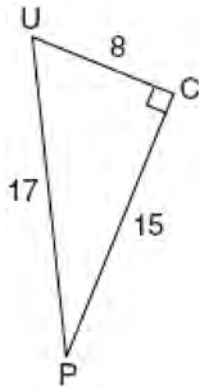

Which ratio represents the sine of $\angle U$?

- $\frac{15}{8}$
- $\frac{15}{17}$
- $\frac{8}{15}$
- $\frac{8}{17}$

- 466 Which ratio represents $\sin x$ in the right triangle shown below?

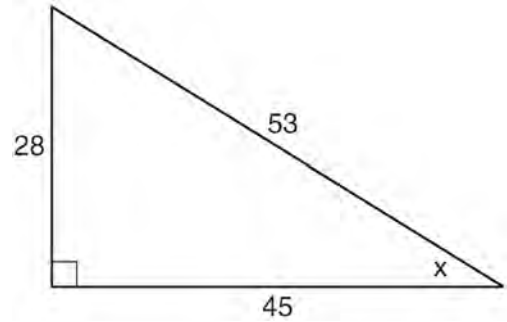

- $\frac{28}{53}$
- $\frac{28}{45}$
- $\frac{45}{53}$
- $\frac{53}{28}$

- 467 The diagram below shows right triangle ABC .

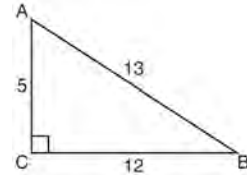

Which ratio represents the tangent of $\angle ABC$?

- $\frac{5}{13}$
- $\frac{5}{12}$
- $\frac{12}{13}$
- $\frac{12}{5}$

468 The diagram below shows right triangle LMP .

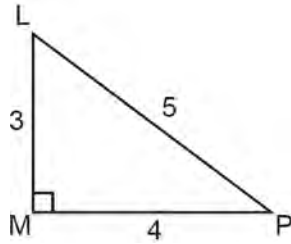

Which ratio represents the tangent of $\angle PLM$?

- 1 $\frac{3}{4}$
- 2 $\frac{3}{5}$
- 3 $\frac{4}{3}$
- 4 $\frac{5}{4}$

469 Right triangle ABC has legs of 8 and 15 and a hypotenuse of 17, as shown in the diagram below.

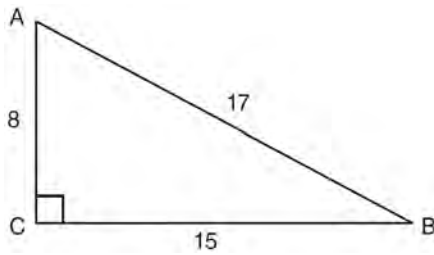

The value of the tangent of $\angle B$ is

- 1 0.4706
- 2 0.5333
- 3 0.8824
- 4 1.8750

470 Which equation shows a correct trigonometric ratio for angle A in the right triangle below?

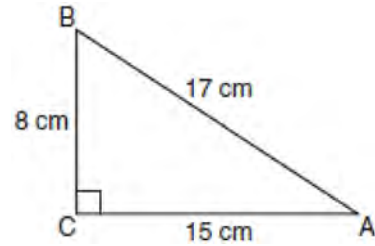

- 1 $\sin A = \frac{15}{17}$
- 2 $\tan A = \frac{8}{17}$
- 3 $\cos A = \frac{15}{17}$
- 4 $\tan A = \frac{5}{8}$

471 In triangle MCT , the measure of $\angle T = 90^\circ$, $MC = 85$ cm, $CT = 84$ cm, and $TM = 13$ cm. Which ratio represents the sine of $\angle C$?

- 1 $\frac{13}{85}$
- 2 $\frac{84}{85}$
- 3 $\frac{13}{84}$
- 4 $\frac{84}{13}$

472 In $\triangle ABC$, the measure of $\angle B = 90^\circ$, $AC = 50$, $AB = 48$, and $BC = 14$. Which ratio represents the tangent of $\angle A$?

- 1 $\frac{14}{50}$
- 2 $\frac{14}{48}$
- 3 $\frac{48}{50}$
- 4 $\frac{48}{14}$

A.A.44: USING TRIGONOMETRY TO FIND A SIDE

473 In the right triangle shown in the diagram below, what is the value of x to the *nearest whole number*?

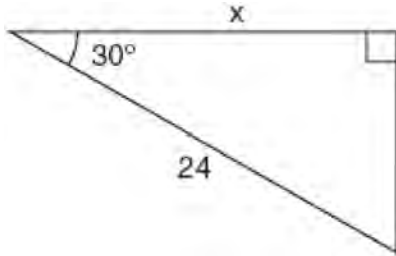

- 1 12
- 2 14
- 3 21
- 4 28

474 A tree casts a 25-foot shadow on a sunny day, as shown in the diagram below.

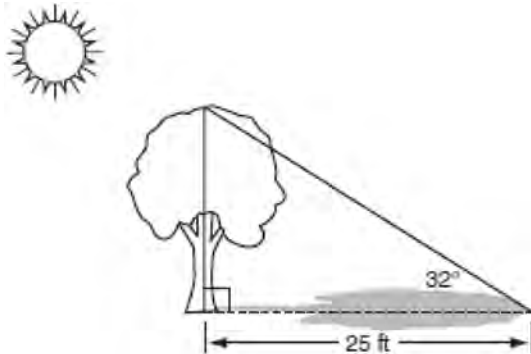

If the angle of elevation from the tip of the shadow to the top of the tree is 32° , what is the height of the tree to the *nearest tenth of a foot*?

- 1 13.2
- 2 15.6
- 3 21.2
- 4 40.0

475 An 8-foot rope is tied from the top of a pole to a stake in the ground, as shown in the diagram below.

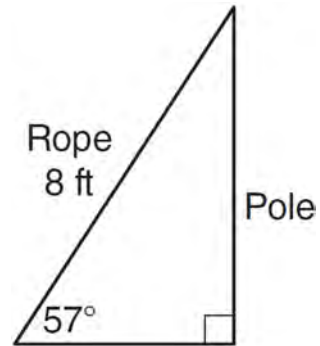

If the rope forms a 57° angle with the ground, what is the height of the pole, to the *nearest tenth of a foot*?

- 1 4.4
- 2 6.7
- 3 9.5
- 4 12.3

476 A right triangle contains a 38° angle whose adjacent side measures 10 centimeters. What is the length of the hypotenuse, to the *nearest hundredth of a centimeter*?

- 1 7.88
- 2 12.69
- 3 12.80
- 4 16.24

- 477 As shown in the diagram below, a ladder 5 feet long leans against a wall and makes an angle of 65° with the ground. Find, to the *nearest tenth of a foot*, the distance from the wall to the base of the ladder.

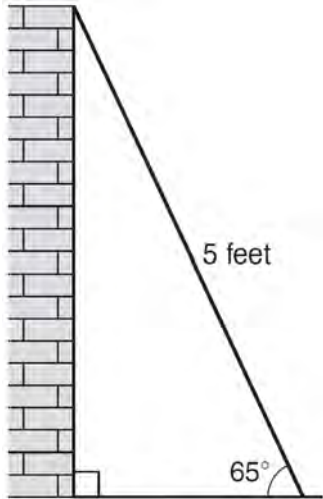

- 478 A stake is to be driven into the ground away from the base of a 50-foot pole, as shown in the diagram below. A wire from the stake on the ground to the top of the pole is to be installed at an angle of elevation of 52° .

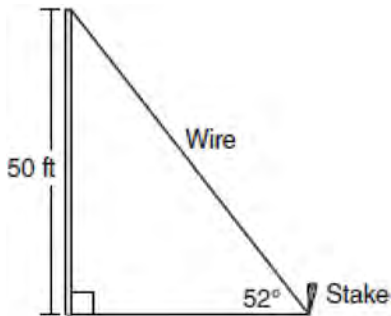

How far away from the base of the pole should the stake be driven in, to the *nearest foot*? What will be the length of the wire from the stake to the top of the pole, to the *nearest foot*?

- 479 A hot-air balloon is tied to the ground with two taut (straight) ropes, as shown in the diagram below. One rope is directly under the balloon and makes a right angle with the ground. The other rope forms an angle of 50° with the ground.

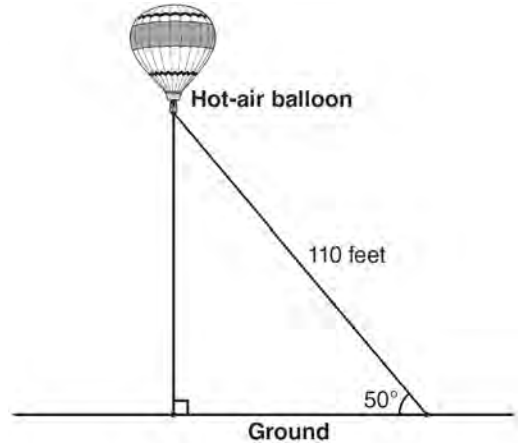

Determine the height, to the *nearest foot*, of the balloon directly above the ground. Determine the distance, to the *nearest foot*, on the ground between the two ropes.

A.A.43: USING TRIGONOMETRY TO FIND AN ANGLE

480 Which equation could be used to find the measure of one acute angle in the right triangle shown below?

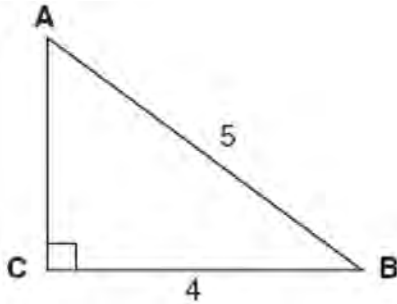

- 1 $\sin A = \frac{4}{5}$
- 2 $\tan A = \frac{5}{4}$
- 3 $\cos B = \frac{5}{4}$
- 4 $\tan B = \frac{4}{5}$

481 In the diagram of $\triangle ABC$ shown below, $BC = 10$ and $AB = 16$.

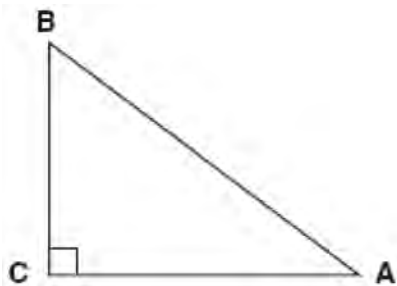

To the *nearest tenth of a degree*, what is the measure of the largest acute angle in the triangle?

- 1 32.0
- 2 38.7
- 3 51.3
- 4 90.0

482 In right triangle ABC shown below, $AB = 18.3$ and $BC = 11.2$.

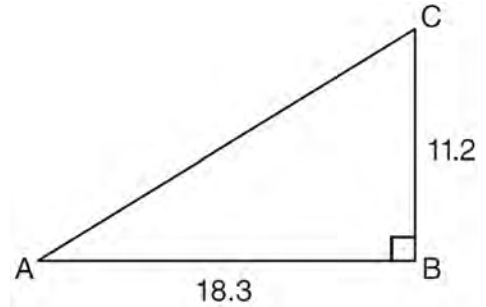

What is the measure of $\angle A$, to the *nearest tenth of a degree*?

- 1 31.5
- 2 37.7
- 3 52.3
- 4 58.5

483 The center pole of a tent is 8 feet long, and a side of the tent is 12 feet long as shown in the diagram below.

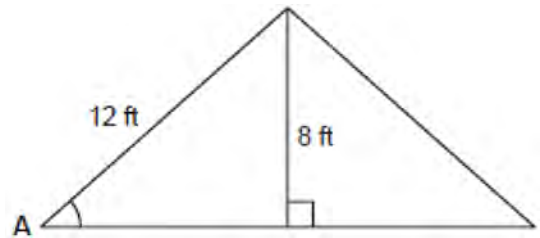

If a right angle is formed where the center pole meets the ground, what is the measure of angle A to the *nearest degree*?

- 1 34
- 2 42
- 3 48
- 4 56

- 484 A communications company is building a 30-foot antenna to carry cell phone transmissions. As shown in the diagram below, a 50-foot wire from the top of the antenna to the ground is used to stabilize the antenna.

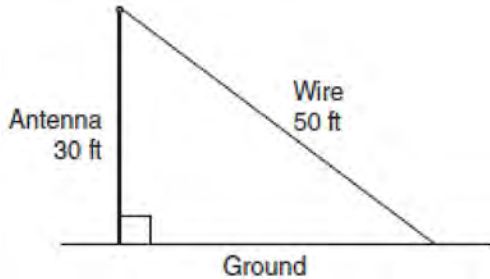

Find, to the *nearest degree*, the measure of the angle that the wire makes with the ground.

- 485 A trapezoid is shown below.

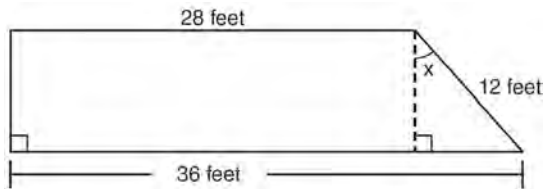

Calculate the measure of angle x , to the *nearest tenth of a degree*.

- 486 In right triangle ABC , $AB = 20$, $AC = 12$, $BC = 16$, and $m\angle C = 90$. Find, to the *nearest degree*, the measure of $\angle A$.

MEASURING IN THE PLANE AND SPACE

A.G.1: COMPOSITIONS OF POLYGONS AND CIRCLES

- 487 A playground in a local community consists of a rectangle and two semicircles, as shown in the diagram below.

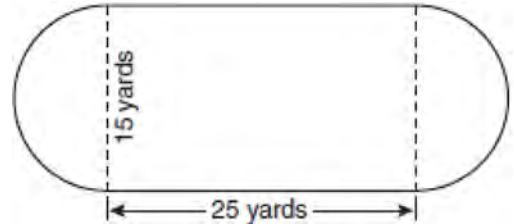

Which expression represents the amount of fencing, in yards, that would be needed to completely enclose the playground?

- 1 $15\pi + 50$
 - 2 $15\pi + 80$
 - 3 $30\pi + 50$
 - 4 $30\pi + 80$
- 488 Luis is going to paint a basketball court on his driveway, as shown in the diagram below. This basketball court consists of a rectangle and a semicircle.

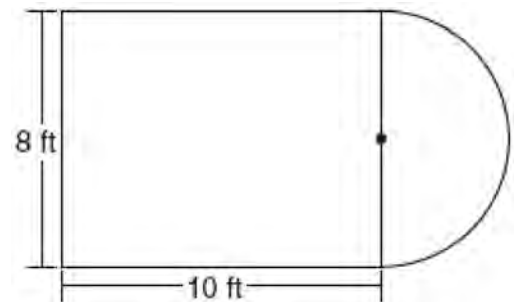

Which expression represents the area of this basketball court, in square feet?

- 1 80
- 2 $80 + 8\pi$
- 3 $80 + 16\pi$
- 4 $80 + 64\pi$

- 489 A figure is made up of a rectangle and a semicircle as shown in the diagram below.

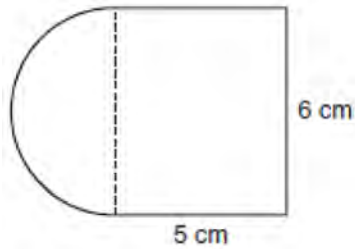

What is the area of the figure, to the *nearest tenth of a square centimeter*?

- 1 39.4
 - 2 44.1
 - 3 48.8
 - 4 58.3
- 490 The figure shown below is composed of two rectangles and a quarter circle.

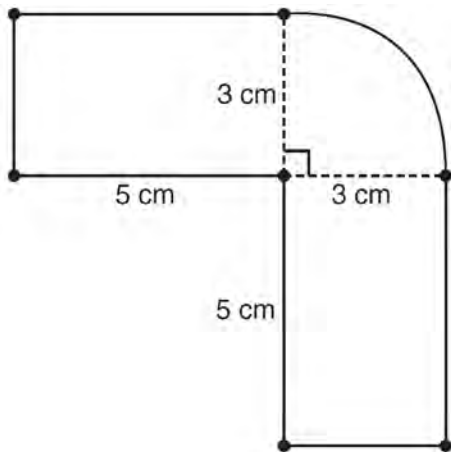

What is the area of this figure, to the *nearest square centimeter*?

- 1 33
- 2 37
- 3 44
- 4 58

- 491 In the diagram below, $MATH$ is a rectangle, $GB = 4.6$, $MH = 6$, and $HT = 15$.

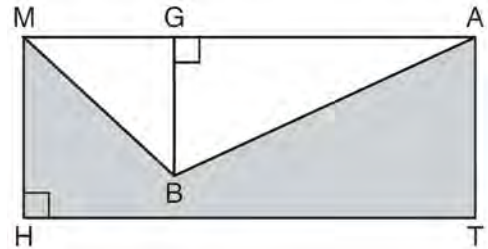

What is the area of polygon $MBATH$?

- 1 34.5
 - 2 55.5
 - 3 90.0
 - 4 124.5
- 492 A garden is in the shape of an isosceles trapezoid and a semicircle, as shown in the diagram below. A fence will be put around the perimeter of the entire garden.

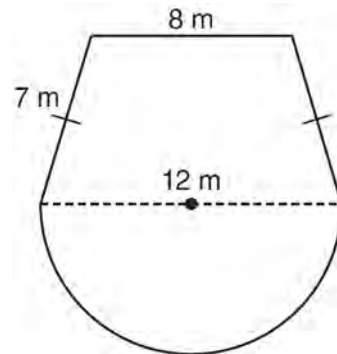

Which expression represents the length of fencing, in meters, that will be needed?

- 1 $22 + 6\pi$
- 2 $22 + 12\pi$
- 3 $15 + 6\pi$
- 4 $15 + 12\pi$

- 493 In the diagram below, circle O is inscribed in square $ABCD$. The square has an area of 36.

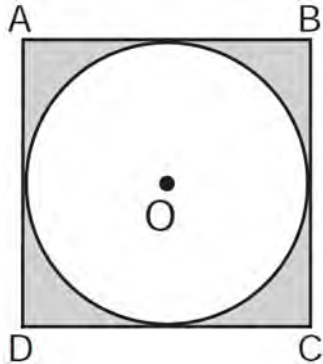

What is the area of the circle?

- 1 9π
 - 2 6π
 - 3 3π
 - 4 36π
- 494 Serena's garden is a rectangle joined with a semicircle, as shown in the diagram below. Line segment AB is the diameter of semicircle P . Serena wants to put a fence around her garden.

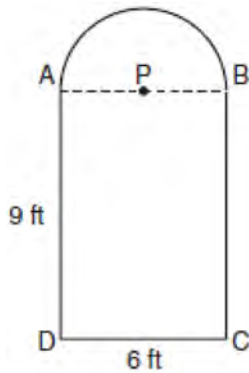

Calculate the length of fence Serena needs to the nearest tenth of a foot.

- 495 A window is made up of a single piece of glass in the shape of a semicircle and a rectangle, as shown in the diagram below. Tess is decorating for a party and wants to put a string of lights all the way around the outside edge of the window.

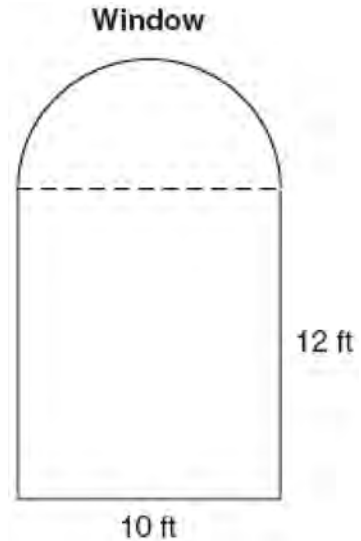

To the nearest foot, what is the length of the string of lights that Tess will need to decorate the window?

- 496 A designer created the logo shown below. The logo consists of a square and four quarter-circles of equal size.

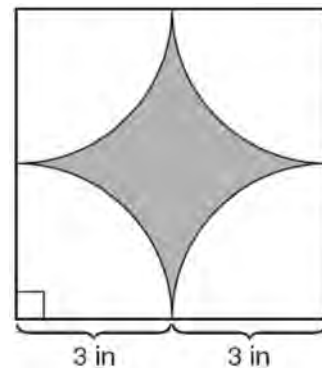

Express, in terms of π , the exact area, in square inches, of the shaded region.

- 497 In the diagram below, the circumference of circle O is 16π inches. The length of \overline{BC} is three-quarters of the length of diameter \overline{AD} and $CE = 4$ inches. Calculate the area, in square inches, of trapezoid $ABCD$.

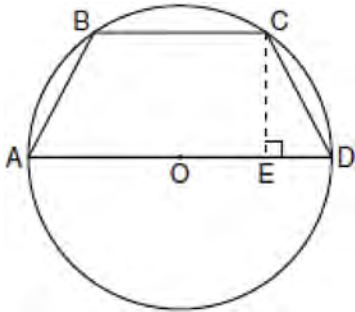

A.G.2: VOLUME

- 498 Lenny made a cube in technology class. Each edge measured 1.5 cm. What is the volume of the cube in cubic centimeters?
- 1 2.25
 - 2 3.375
 - 3 9.0
 - 4 13.5

- 499 A cylindrical container has a diameter of 12 inches and a height of 15 inches, as illustrated in the diagram below.

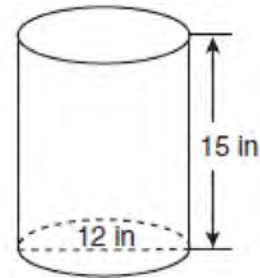

(Not drawn to scale)

- What is the volume of this container to the *nearest tenth* of a cubic inch?
- 1 6,785.8
 - 2 4,241.2
 - 3 2,160.0
 - 4 1,696.5
- 500 A cylinder has a diameter of 10 inches and a height of 2.3 inches. What is the volume of this cylinder, to the *nearest tenth of a cubic inch*?
- 1 72.3
 - 2 83.1
 - 3 180.6
 - 4 722.6
- 501 A soup can is in the shape of a cylinder. The can has a volume of 342 cm^3 and a diameter of 6 cm. Express the height of the can in terms of π . Determine the maximum number of soup cans that can be stacked on their base between two shelves if the distance between the shelves is exactly 36 cm. Explain your answer.

- 502 The diagram below represents Joe's two fish tanks.

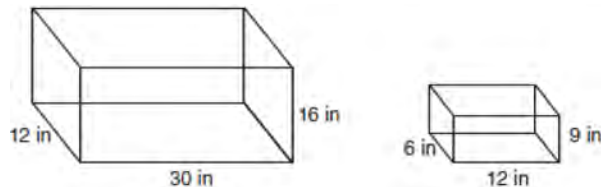

Joe's larger tank is completely filled with water. He takes water from it to completely fill the small tank. Determine how many cubic inches of water will remain in the larger tank.

- 506 The length and width of the base of a rectangular prism are 5.5 cm and 3 cm. The height of the prism is 6.75 cm. Find the *exact* value of the surface area of the prism, in square centimeters.

- 507 A plastic storage box in the shape of a rectangular prism has a length of $x + 3$, a width of $x - 4$, and a height of 5. Represent the surface area of the box as a trinomial in terms of x .

A.G.2: SURFACE AREA

- 503 How many square inches of wrapping paper are needed to entirely cover a box that is 2 inches by 3 inches by 4 inches?

- 1 18
- 2 24
- 3 26
- 4 52

- 504 Mrs. Ayer is painting the outside of her son's toy box, including the top and bottom. The toy box measures 3 feet long, 1.5 feet wide, and 2 feet high. What is the total surface area she will paint?

- 1 9.0 ft^2
- 2 13.5 ft^2
- 3 22.5 ft^2
- 4 27.0 ft^2

- 505 Find the volume, in cubic centimeters, *and* the surface area, in square centimeters, of the rectangular prism shown below.

