

# JEFFERSON MATH PROJECT

## REGENTS BY DATE

The NY Geometry Regents Exams  
Fall, 2008-August, 2011

[www.jmap.org](http://www.jmap.org)

Dear Sir

I have to acknowledge the receipt of your favor of May 14. in which you mention that you have finished the 6. first books of Euclid, plane trigonometry, surveying & algebra and ask whether I think a further pursuit of that branch of science would be useful to you. there are some propositions in the latter books of Euclid, & some of Archimedes, which are useful, & I have no doubt you have been made acquainted with them. trigonometry, so far as this, is most valuable to every man, there is scarcely a day in which he will not resort to it for some of the purposes of common life. the science of calculation also is indispensable as far as the extraction of the square & cube roots; Algebra as far as the quadratic equation & the use of logarithms are often of value in ordinary cases: but all beyond these is but a luxury; a delicious luxury indeed; but not to be indulged in by one who is to have a profession to follow for his subsistence. in this light I view the conic sections, curves of the higher orders, perhaps even spherical trigonometry, Algebraical operations beyond the 2d dimension, and fluxions.

**Letter from Thomas Jefferson to William G. Munford, Monticello, June 18, 1799.**

**fall08ge**

- 1 Isosceles trapezoid  $ABCD$  has diagonals  $\overline{AC}$  and  $\overline{BD}$ . If  $AC = 5x + 13$  and  $BD = 11x - 5$ , what is the value of  $x$ ?
  - 1) 28
  - 2)  $10\frac{3}{4}$
  - 3) 3
  - 4)  $\frac{1}{2}$
  
- 2 What is the negation of the statement “The Sun is shining”?
  - 1) It is cloudy.
  - 2) It is daytime.
  - 3) It is not raining.
  - 4) The Sun is not shining.
  
- 3 Triangle  $ABC$  has vertices  $A(1,3)$ ,  $B(0,1)$ , and  $C(4,0)$ . Under a translation,  $A'$ , the image point of  $A$ , is located at  $(4,4)$ . Under this same translation, point  $C'$  is located at
  - 1)  $(7,1)$
  - 2)  $(5,3)$
  - 3)  $(3,2)$
  - 4)  $(1,-1)$

- 4 The diagram below shows the construction of the perpendicular bisector of  $\overline{AB}$ .

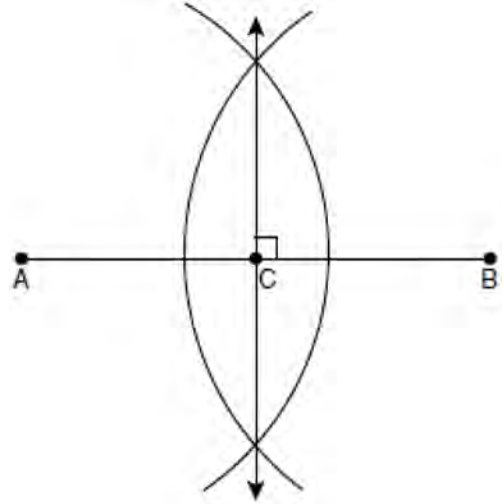

Which statement is *not* true?

- 1)  $AC = CB$
- 2)  $CB = \frac{1}{2}AB$
- 3)  $AC = 2AB$
- 4)  $AC + CB = AB$

- 5 Which graph could be used to find the solution to the following system of equations?

$$y = -x + 2$$

$$y = x^2$$

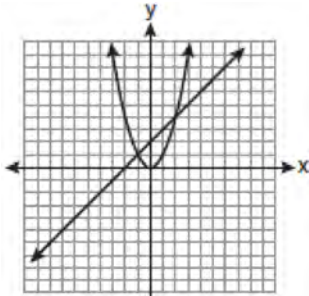

1)

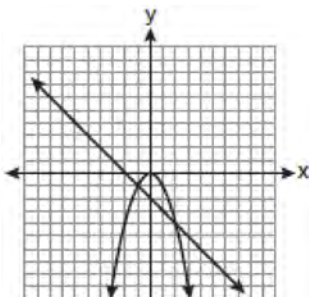

2)

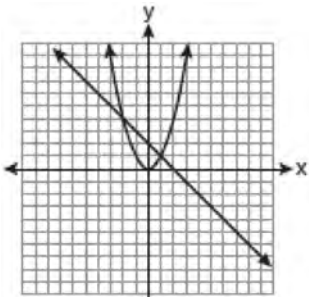

3)

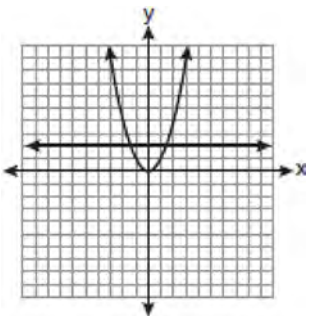

4)

- 6 Line  $k$  is drawn so that it is perpendicular to two distinct planes,  $P$  and  $R$ . What must be true about planes  $P$  and  $R$ ?

- 1) Planes  $P$  and  $R$  are skew.
- 2) Planes  $P$  and  $R$  are parallel.
- 3) Planes  $P$  and  $R$  are perpendicular.
- 4) Plane  $P$  intersects plane  $R$  but is not perpendicular to plane  $R$ .

- 7 The diagram below illustrates the construction of  $\overleftrightarrow{PS}$  parallel to  $\overleftrightarrow{RQ}$  through point  $P$ .

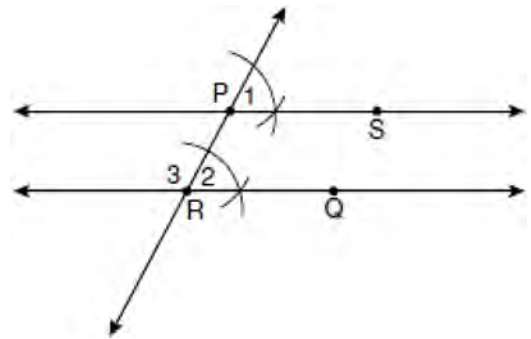

Which statement justifies this construction?

- 1)  $m\angle 1 = m\angle 2$
- 2)  $m\angle 1 = m\angle 3$
- 3)  $\overline{PR} \cong \overline{RQ}$
- 4)  $\overline{PS} \cong \overline{RQ}$

- 8 The figure in the diagram below is a triangular prism.

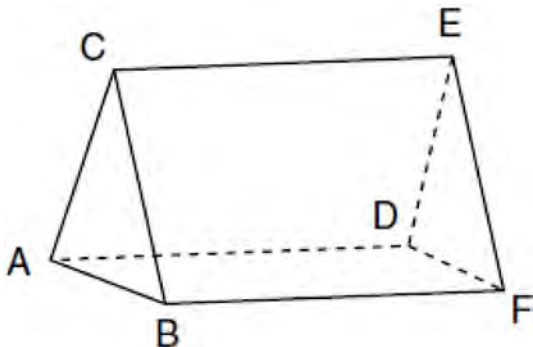

Which statement must be true?

- 1)  $\overline{DE} \cong \overline{AB}$
- 2)  $\overline{AD} \cong \overline{BC}$
- 3)  $\overline{AD} \parallel \overline{CE}$
- 4)  $\overline{DE} \parallel \overline{BC}$

- 9 The vertices of  $\triangle ABC$  are  $A(-1,-2)$ ,  $B(-1,2)$  and  $C(6,0)$ . Which conclusion can be made about the angles of  $\triangle ABC$ ?
- 1)  $m\angle A = m\angle B$
  - 2)  $m\angle A = m\angle C$
  - 3)  $m\angle ACB = 90$
  - 4)  $m\angle ABC = 60$

- 10 Given  $\triangle ABC$  with base  $\overline{AFEDC}$ , median  $\overline{BF}$ , altitude  $\overline{BD}$ , and  $\overline{BE}$  bisects  $\angle ABC$ , which conclusion is valid?

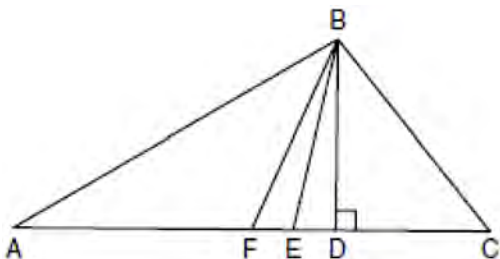

- 1)  $\angle FAB \cong \angle ABF$
- 2)  $\angle ABF \cong \angle CBD$
- 3)  $\overline{CE} \cong \overline{EA}$
- 4)  $\overline{CF} \cong \overline{FA}$

- 11 In the diagram below, circle  $O$  has a radius of 5, and  $\overline{CE} = 2$ . Diameter  $\overline{AC}$  is perpendicular to chord  $\overline{BD}$  at  $E$ .

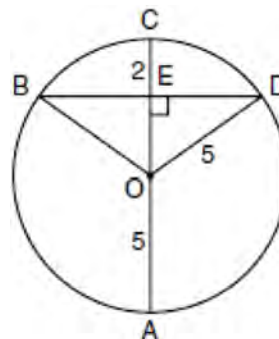

What is the length of  $\overline{BD}$ ?

- 1) 12
  - 2) 10
  - 3) 8
  - 4) 4
- 12 What is the equation of a line that passes through the point  $(-3,-11)$  and is parallel to the line whose equation is  $2x - y = 4$ ?
- 1)  $y = 2x + 5$
  - 2)  $y = 2x - 5$
  - 3)  $y = \frac{1}{2}x + \frac{25}{2}$
  - 4)  $y = -\frac{1}{2}x - \frac{25}{2}$
- 13 Line segment  $\overline{AB}$  has endpoints  $A(2,-3)$  and  $B(-4,6)$ . What are the coordinates of the midpoint of  $\overline{AB}$ ?
- 1)  $(-2,3)$
  - 2)  $(-1, 1\frac{1}{2})$
  - 3)  $(-1,3)$
  - 4)  $(3, 4\frac{1}{2})$

- 14 What are the center and radius of a circle whose equation is  $(x - A)^2 + (y - B)^2 = C$ ?
- 1) center =  $(A, B)$ ; radius =  $C$
  - 2) center =  $(-A, -B)$ ; radius =  $C$
  - 3) center =  $(A, B)$ ; radius =  $\sqrt{C}$
  - 4) center =  $(-A, -B)$ ; radius =  $\sqrt{C}$

- 15 A rectangular prism has a volume of  $3x^2 + 18x + 24$ . Its base has a length of  $x + 2$  and a width of 3. Which expression represents the height of the prism?
- 1)  $x + 4$
  - 2)  $x + 2$
  - 3) 3
  - 4)  $x^2 + 6x + 8$

- 16 Lines  $k_1$  and  $k_2$  intersect at point  $E$ . Line  $m$  is perpendicular to lines  $k_1$  and  $k_2$  at point  $E$ .

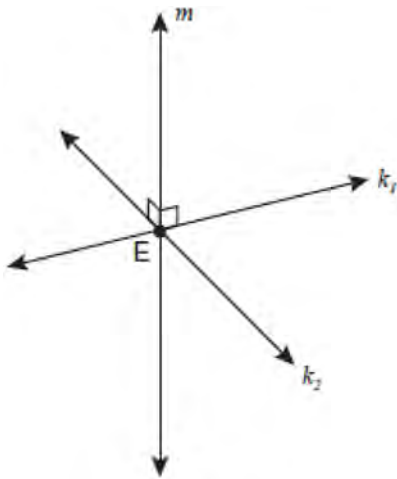

Which statement is always true?

- 1) Lines  $k_1$  and  $k_2$  are perpendicular.
- 2) Line  $m$  is parallel to the plane determined by lines  $k_1$  and  $k_2$ .
- 3) Line  $m$  is perpendicular to the plane determined by lines  $k_1$  and  $k_2$ .
- 4) Line  $m$  is coplanar with lines  $k_1$  and  $k_2$ .

- 17 In the diagram below,  $\overline{PS}$  is a tangent to circle  $O$  at point  $S$ ,  $\overline{PQR}$  is a secant,  $PS = x$ ,  $PQ = 3$ , and  $PR = x + 18$ .

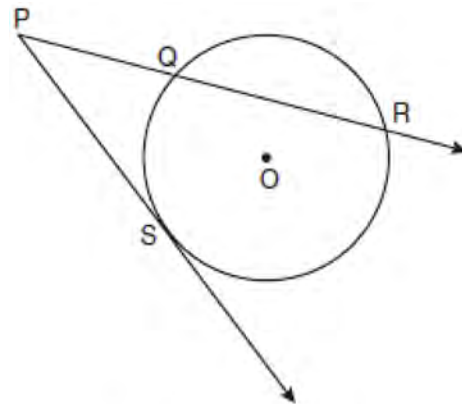

(Not drawn to scale)

What is the length of  $\overline{PS}$ ?

- 1) 6
  - 2) 9
  - 3) 3
  - 4) 27
- 18 A polygon is transformed according to the rule:  $(x, y) \rightarrow (x + 2, y)$ . Every point of the polygon moves two units in which direction?
- 1) up
  - 2) down
  - 3) left
  - 4) right

- 19 In the diagram below of  $\triangle ABC$ ,  $D$  is a point on  $\overline{AB}$ ,  $AC = 7$ ,  $AD = 6$ , and  $BC = 18$ .

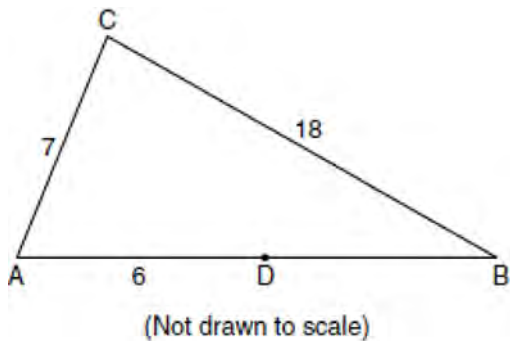

The length of  $\overline{DB}$  could be

- 1) 5
  - 2) 12
  - 3) 19
  - 4) 25
- 20 The diameter of a circle has endpoints at  $(-2,3)$  and  $(6,3)$ . What is an equation of the circle?
- 1)  $(x-2)^2 + (y-3)^2 = 16$
  - 2)  $(x-2)^2 + (y-3)^2 = 4$
  - 3)  $(x+2)^2 + (y+3)^2 = 16$
  - 4)  $(x+2)^2 + (y+3)^2 = 4$

- 21 In the diagram below of  $\triangle PRT$ ,  $Q$  is a point on  $\overline{PR}$ ,  $S$  is a point on  $\overline{TR}$ ,  $\overline{QS}$  is drawn, and  $\angle RPT \cong \angle RSQ$ .

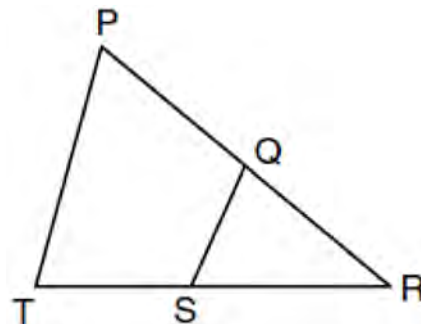

Which reason justifies the conclusion that  $\triangle PRT \sim \triangle SRQ$ ?

- 1) AA
  - 2) ASA
  - 3) SAS
  - 4) SSS
- 22 The lines  $3y + 1 = 6x + 4$  and  $2y + 1 = x - 9$  are
- 1) parallel
  - 2) perpendicular
  - 3) the same line
  - 4) neither parallel nor perpendicular
- 23 The endpoints of  $\overline{AB}$  are  $A(3,2)$  and  $B(7,1)$ . If  $\overline{A''B''}$  is the result of the transformation of  $\overline{AB}$  under  $D_2 \circ T_{-4,3}$  what are the coordinates of  $A''$  and  $B''$ ?
- 1)  $A''(-2,10)$  and  $B''(6,8)$
  - 2)  $A''(-1,5)$  and  $B''(3,4)$
  - 3)  $A''(2,7)$  and  $B''(10,5)$
  - 4)  $A''(14,-2)$  and  $B''(22,-4)$

- 24 In the diagram below, circle  $A$  and circle  $B$  are shown.

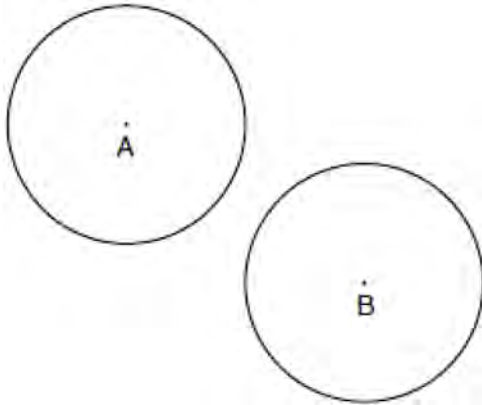

What is the total number of lines of tangency that are common to circle  $A$  and circle  $B$ ?

- 1) 1
  - 2) 2
  - 3) 3
  - 4) 4
- 25 In which triangle do the three altitudes intersect outside the triangle?
- 1) a right triangle
  - 2) an acute triangle
  - 3) an obtuse triangle
  - 4) an equilateral triangle
- 26 Two triangles are similar, and the ratio of each pair of corresponding sides is 2:1. Which statement regarding the two triangles is *not* true?
- 1) Their areas have a ratio of 4:1.
  - 2) Their altitudes have a ratio of 2:1.
  - 3) Their perimeters have a ratio of 2:1.
  - 4) Their corresponding angles have a ratio of 2:1.
- 27 What is the measure of an interior angle of a regular octagon?
- 1)  $45^\circ$
  - 2)  $60^\circ$
  - 3)  $120^\circ$
  - 4)  $135^\circ$

- 28 What is the slope of a line perpendicular to the line whose equation is  $5x + 3y = 8$ ?

- 1)  $\frac{5}{3}$
- 2)  $\frac{3}{5}$
- 3)  $-\frac{3}{5}$
- 4)  $-\frac{5}{3}$

- 29 In the diagram below of right triangle  $ACB$ , altitude  $\overline{CD}$  intersects  $\overline{AB}$  at  $D$ . If  $AD = 3$  and  $DB = 4$ , find the length of  $CD$  in simplest radical form.

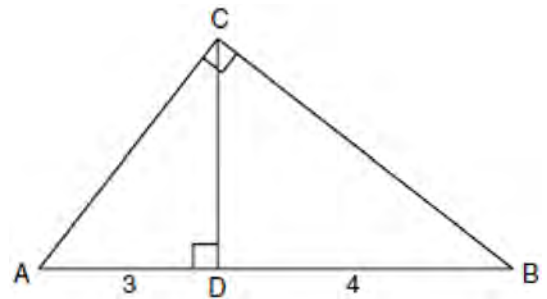

- 30 The vertices of  $\triangle ABC$  are  $A(3,2)$ ,  $B(6,1)$ , and  $C(4,6)$ . Identify and graph a transformation of  $\triangle ABC$  such that its image,  $\triangle A'B'C'$ , results in  $\overline{AB} \parallel \overline{A'B'}$ .

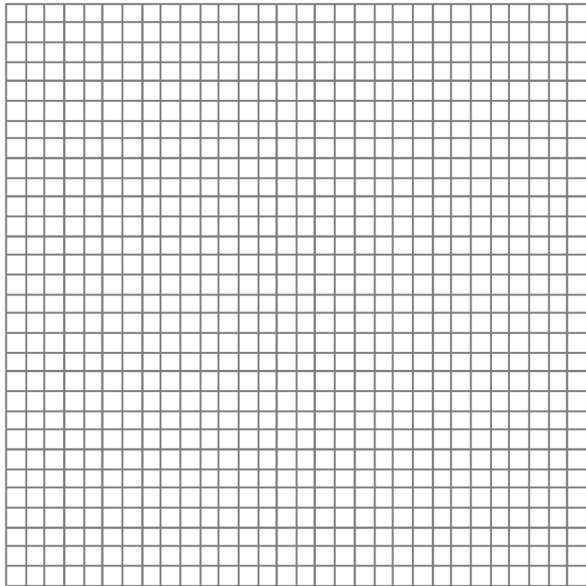

- 31 The endpoints of  $\overline{PQ}$  are  $P(-3,1)$  and  $Q(4,25)$ . Find the length of  $\overline{PQ}$ .

- 32 Using a compass and straightedge, construct the bisector of the angle shown below. [Leave all construction marks.]

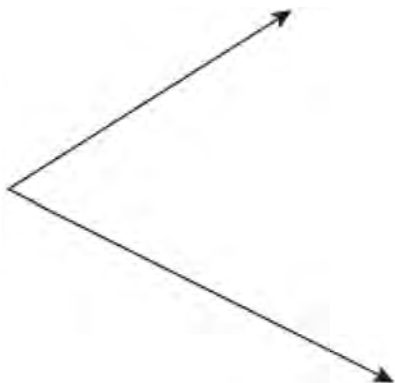

- 33 The volume of a cylinder is  $12,566.4 \text{ cm}^3$ . The height of the cylinder is 8 cm. Find the radius of the cylinder to the nearest tenth of a centimeter.
- 34 Write a statement that is logically equivalent to the statement “If two sides of a triangle are congruent, the angles opposite those sides are congruent.” Identify the new statement as the converse, inverse, or contrapositive of the original statement.
- 35 On the set of axes below, graph and label  $\triangle DEF$  with vertices at  $D(-4,-4)$ ,  $E(-2,2)$ , and  $F(8,-2)$ . If  $G$  is the midpoint of  $\overline{EF}$  and  $H$  is the midpoint of  $\overline{DF}$ , state the coordinates of  $G$  and  $H$  and label each point on your graph. Explain why  $\overline{GH} \parallel \overline{DE}$ .

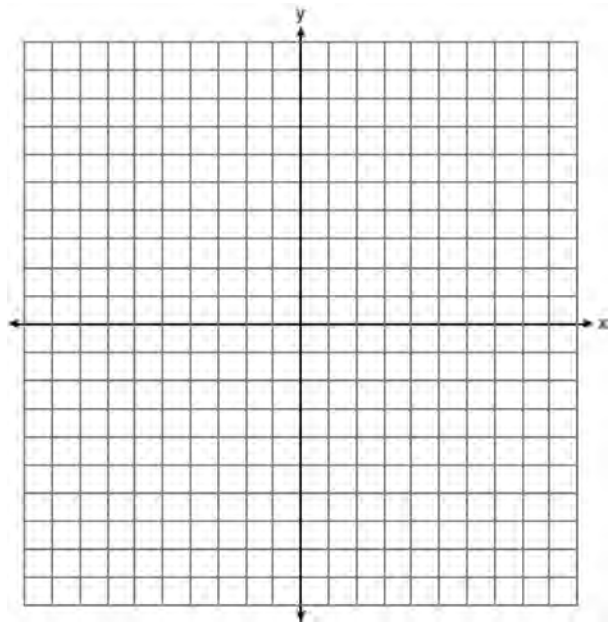



- 36 In the diagram below of circle  $O$ , chords  $\overline{DF}$ ,  $\overline{DE}$ ,  $\overline{FG}$ , and  $\overline{EG}$  are drawn such that  $m\widehat{DF} : m\widehat{FE} : m\widehat{EG} : m\widehat{GD} = 5 : 2 : 1 : 7$ . Identify one pair of inscribed angles that are congruent to each other and give their measure.

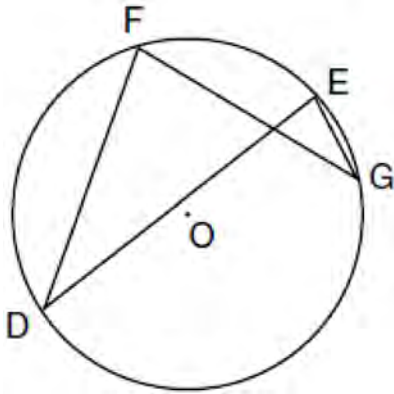

- 37 A city is planning to build a new park. The park must be equidistant from school  $A$  at  $(3,3)$  and school  $B$  at  $(3,-5)$ . The park also must be exactly 5 miles from the center of town, which is located at the origin on the coordinate graph. Each unit on the graph represents 1 mile. On the set of axes below, sketch the compound loci and label with an **X** all possible locations for the new park.

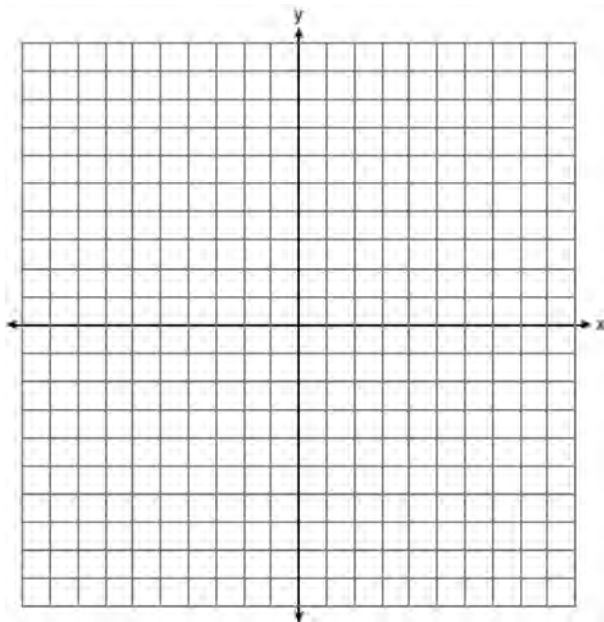

- 38 In the diagram below, quadrilateral  $ABCD$  is inscribed in circle  $O$ ,  $\overline{AB} \parallel \overline{DC}$ , and diagonals  $\overline{AC}$  and  $\overline{BD}$  are drawn. Prove that  $\triangle ACD \cong \triangle BDC$ .

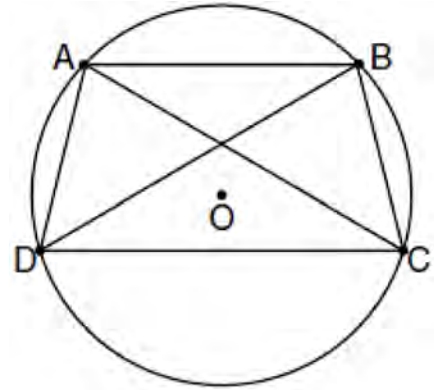

0609ge

- 1 Juliann plans on drawing  $\triangle ABC$ , where the measure of  $\angle A$  can range from  $50^\circ$  to  $60^\circ$  and the measure of  $\angle B$  can range from  $90^\circ$  to  $100^\circ$ . Given these conditions, what is the correct range of measures possible for  $\angle C$ ?
- 1)  $20^\circ$  to  $40^\circ$
  - 2)  $30^\circ$  to  $50^\circ$
  - 3)  $80^\circ$  to  $90^\circ$
  - 4)  $120^\circ$  to  $130^\circ$

- 2 In the diagram of  $\triangle ABC$  and  $\triangle DEF$  below,  $\overline{AB} \cong \overline{DE}$ ,  $\angle A \cong \angle D$ , and  $\angle B \cong \angle E$ .

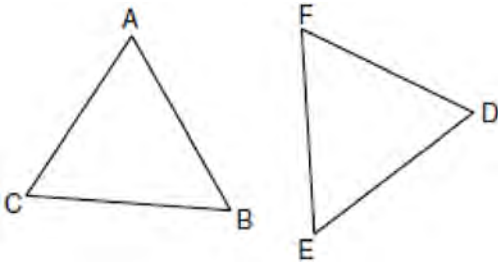

Which method can be used to prove  $\triangle ABC \cong \triangle DEF$ ?

- 1) SSS
- 2) SAS
- 3) ASA
- 4) HL

- 3 In the diagram below, under which transformation will  $\triangle A'B'C'$  be the image of  $\triangle ABC$ ?

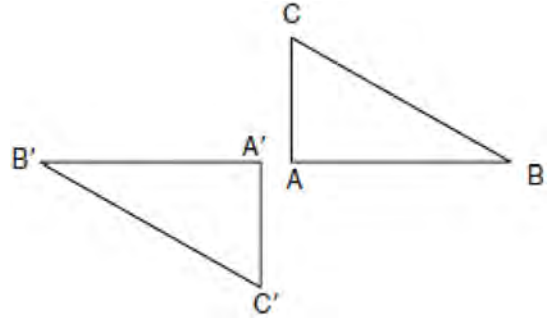

- 1) rotation
  - 2) dilation
  - 3) translation
  - 4) glide reflection
- 4 The lateral faces of a regular pyramid are composed of
- 1) squares
  - 2) rectangles
  - 3) congruent right triangles
  - 4) congruent isosceles triangles
- 5 Point A is located at  $(4, -7)$ . The point is reflected in the  $x$ -axis. Its image is located at
- 1)  $(-4, 7)$
  - 2)  $(-4, -7)$
  - 3)  $(4, 7)$
  - 4)  $(7, -4)$

- 6 In the diagram of circle  $O$  below, chords  $\overline{AB}$  and  $\overline{CD}$  are parallel, and  $\overline{BD}$  is a diameter of the circle.

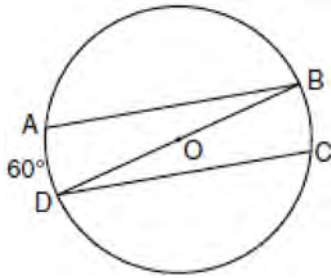

If  $m\widehat{AD} = 60$ , what is  $m\angle CDB$ ?

- 1) 20
  - 2) 30
  - 3) 60
  - 4) 120
- 7 What is an equation of the line that passes through the point  $(-2,5)$  and is perpendicular to the line whose equation is  $y = \frac{1}{2}x + 5$ ?
- 1)  $y = 2x + 1$
  - 2)  $y = -2x + 1$
  - 3)  $y = 2x + 9$
  - 4)  $y = -2x - 9$

- 8 After a composition of transformations, the coordinates  $A(4,2)$ ,  $B(4,6)$ , and  $C(2,6)$  become  $A''(-2,-1)$ ,  $B''(-2,-3)$ , and  $C''(-1,-3)$ , as shown on the set of axes below.

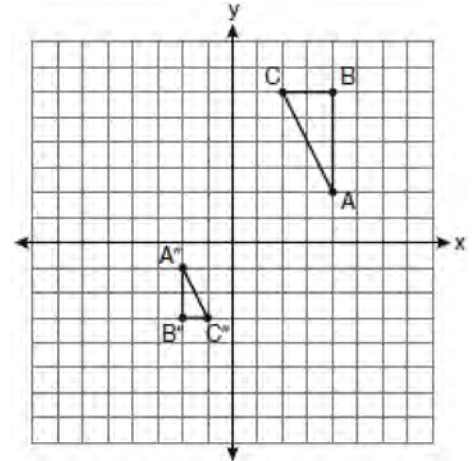

Which composition of transformations was used?

- 1)  $R_{180^\circ} \circ D_2$
  - 2)  $R_{90^\circ} \circ D_2$
  - 3)  $D_{\frac{1}{2}} \circ R_{180^\circ}$
  - 4)  $D_{\frac{1}{2}} \circ R_{90^\circ}$
- 9 In an equilateral triangle, what is the difference between the sum of the exterior angles and the sum of the interior angles?
- 1)  $180^\circ$
  - 2)  $120^\circ$
  - 3)  $90^\circ$
  - 4)  $60^\circ$
- 10 What is an equation of a circle with its center at  $(-3,5)$  and a radius of 4?
- 1)  $(x-3)^2 + (y+5)^2 = 16$
  - 2)  $(x+3)^2 + (y-5)^2 = 16$
  - 3)  $(x-3)^2 + (y+5)^2 = 4$
  - 4)  $(x+3)^2 + (y-5)^2 = 4$

- 11 In  $\triangle ABC$ ,  $m\angle A = 95$ ,  $m\angle B = 50$ , and  $m\angle C = 35$ . Which expression correctly relates the lengths of the sides of this triangle?
- 1)  $AB < BC < CA$
  - 2)  $AB < AC < BC$
  - 3)  $AC < BC < AB$
  - 4)  $BC < AC < AB$

- 12 In a coordinate plane, how many points are both 5 units from the origin and 2 units from the  $x$ -axis?
- 1) 1
  - 2) 2
  - 3) 3
  - 4) 4

- 13 What is the contrapositive of the statement, "If I am tall, then I will bump my head"?
- 1) If I bump my head, then I am tall.
  - 2) If I do not bump my head, then I am tall.
  - 3) If I am tall, then I will not bump my head.
  - 4) If I do not bump my head, then I am not tall.

- 14 In the diagram of  $\triangle ABC$  below, Jose found centroid  $P$  by constructing the three medians. He measured  $CF$  and found it to be 6 inches.

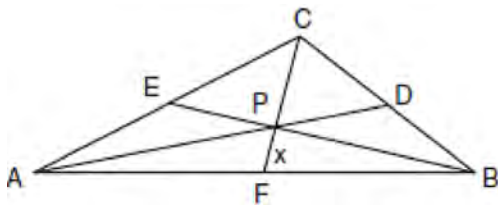

If  $PF = x$ , which equation can be used to find  $x$ ?

- 1)  $x + x = 6$
- 2)  $2x + x = 6$
- 3)  $3x + 2x = 6$
- 4)  $x + \frac{2}{3}x = 6$

- 15 In the diagram below, the length of the legs  $\overline{AC}$  and  $\overline{BC}$  of right triangle  $ABC$  are 6 cm and 8 cm, respectively. Altitude  $\overline{CD}$  is drawn to the hypotenuse of  $\triangle ABC$ .

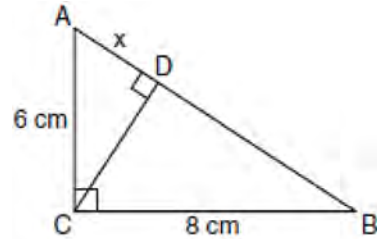

What is the length of  $\overline{AD}$  to the nearest tenth of a centimeter?

- 1) 3.6
- 2) 6.0
- 3) 6.4
- 4) 4.0

- 16 In the diagram below, tangent  $\overline{AB}$  and secant  $\overline{ACD}$  are drawn to circle  $O$  from an external point  $A$ ,  $AB = 8$ , and  $AC = 4$ .

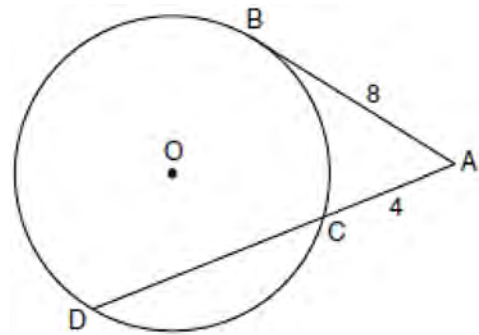

What is the length of  $\overline{CD}$ ?

- 1) 16
- 2) 13
- 3) 12
- 4) 10

- 17 In the diagram of  $\triangle ABC$  and  $\triangle EDC$  below,  $\overline{AE}$  and  $\overline{BD}$  intersect at  $C$ , and  $\angle CAB \cong \angle CED$ .

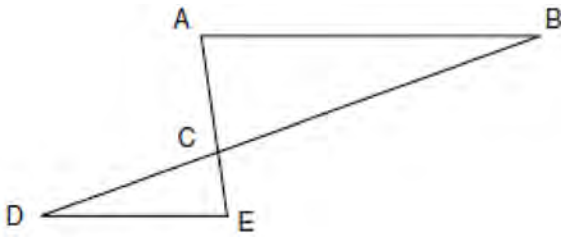

Which method can be used to show that  $\triangle ABC$  must be similar to  $\triangle EDC$ ?

- 1) SAS
  - 2) AA
  - 3) SSS
  - 4) HL
- 18 Point  $P$  is on line  $m$ . What is the total number of planes that are perpendicular to line  $m$  and pass through point  $P$ ?
- 1) 1
  - 2) 2
  - 3) 0
  - 4) infinite

- 19 Square  $LMNO$  is shown in the diagram below.

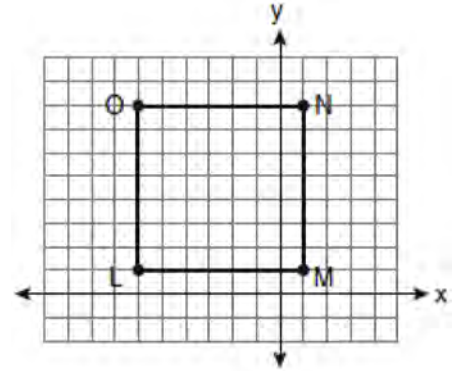

What are the coordinates of the midpoint of diagonal  $\overline{LN}$ ?

- 1)  $\left(4\frac{1}{2}, -2\frac{1}{2}\right)$
- 2)  $\left(-3\frac{1}{2}, 3\frac{1}{2}\right)$
- 3)  $\left(-2\frac{1}{2}, 3\frac{1}{2}\right)$
- 4)  $\left(-2\frac{1}{2}, 4\frac{1}{2}\right)$

- 20 Which graph represents a circle with the equation  $(x-5)^2 + (y+1)^2 = 9$ ?

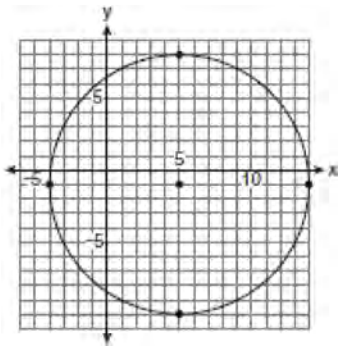
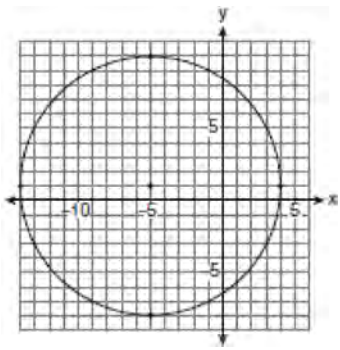
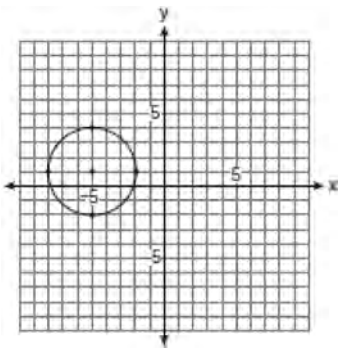
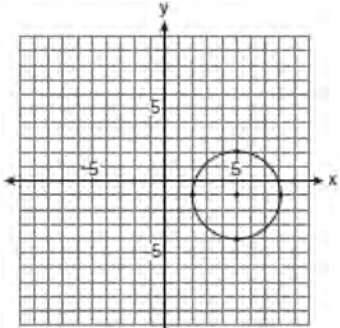

- 21 In the diagram below, a right circular cone has a diameter of 8 inches and a height of 12 inches.

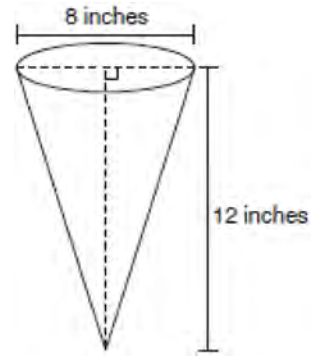

What is the volume of the cone to the *nearest cubic inch*?

- 1) 201  
 2) 481  
 3) 603  
 4) 804
- 22 A circle is represented by the equation  $x^2 + (y+3)^2 = 13$ . What are the coordinates of the center of the circle and the length of the radius?
- 1) (0,3) and 13  
 2) (0,3) and  $\sqrt{13}$   
 3) (0,-3) and 13  
 4) (0,-3) and  $\sqrt{13}$
- 23 Given the system of equations:  $y = x^2 - 4x$   
 $x = 4$

The number of points of intersection is

- 1) 1  
 2) 2  
 3) 3  
 4) 0

- 24 Side  $\overline{PQ}$  of  $\triangle PQR$  is extended through  $Q$  to point  $T$ . Which statement is *not* always true?
- 1)  $m\angle RQT > m\angle R$
  - 2)  $m\angle RQT > m\angle P$
  - 3)  $m\angle RQT = m\angle P + m\angle R$
  - 4)  $m\angle RQT > m\angle PQR$

- 25 Which illustration shows the correct construction of an angle bisector?

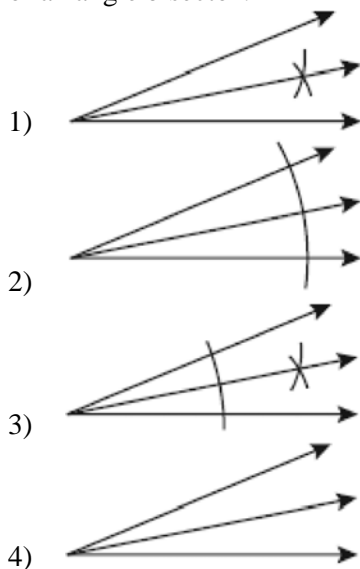

- 26 Which equation represents a line perpendicular to the line whose equation is  $2x + 3y = 12$ ?
- 1)  $6y = -4x + 12$
  - 2)  $2y = 3x + 6$
  - 3)  $2y = -3x + 6$
  - 4)  $3y = -2x + 12$

- 27 In  $\triangle ABC$ , point  $D$  is on  $\overline{AB}$ , and point  $E$  is on  $\overline{BC}$  such that  $\overline{DE} \parallel \overline{AC}$ . If  $DB = 2$ ,  $DA = 7$ , and  $DE = 3$ , what is the length of  $\overline{AC}$ ?
- 1) 8
  - 2) 9
  - 3) 10.5
  - 4) 13.5

- 28 In three-dimensional space, two planes are parallel and a third plane intersects both of the parallel planes. The intersection of the planes is a
- 1) plane
  - 2) point
  - 3) pair of parallel lines
  - 4) pair of intersecting lines

- 29 In the diagram of  $\triangle ABC$  below,  $AB = 10$ ,  $BC = 14$ , and  $AC = 16$ . Find the perimeter of the triangle formed by connecting the midpoints of the sides of  $\triangle ABC$ .

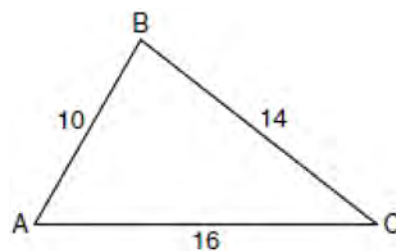

- 30 Using a compass and straightedge, construct a line that passes through point  $P$  and is perpendicular to line  $m$ . [Leave all construction marks.]



- 31 Find an equation of the line passing through the point  $(5, 4)$  and parallel to the line whose equation is  $2x + y = 3$ .

- 32 The length of  $\overline{AB}$  is 3 inches. On the diagram below, sketch the points that are equidistant from  $A$  and  $B$  and sketch the points that are 2 inches from  $A$ . Label with an **X** all points that satisfy both conditions.



- 33 Given: Two is an even integer or three is an even integer.  
Determine the truth value of this disjunction.  
Justify your answer.

- 35 In the diagram below, circles  $X$  and  $Y$  have two tangents drawn to them from external point  $T$ . The points of tangency are  $C$ ,  $A$ ,  $S$ , and  $E$ . The ratio of  $\overline{TA}$  to  $\overline{AC}$  is  $1:3$ . If  $TS = 24$ , find the length of  $\overline{SE}$ .

- 34 In the diagram below,  $\triangle ABC \sim \triangle EFG$ ,  $m\angle C = 4x + 30$ , and  $m\angle G = 5x + 10$ . Determine the value of  $x$ .

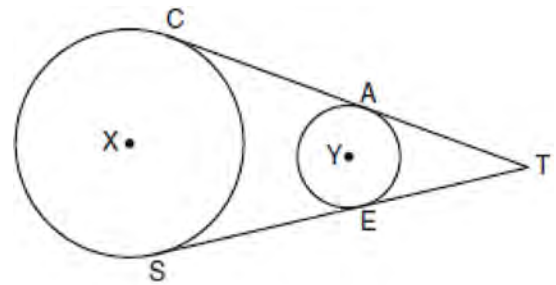
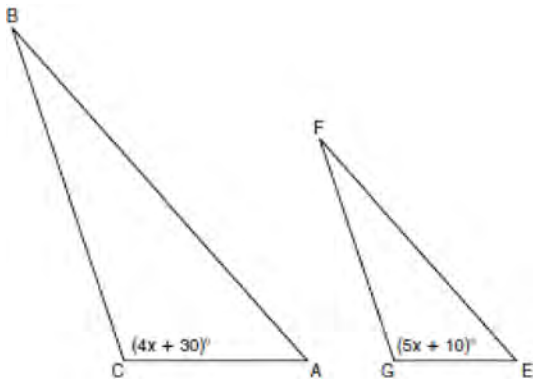

(Not drawn to scale)



- 36 Triangle  $ABC$  has coordinates  $A(-6,2)$ ,  $B(-3,6)$ , and  $C(5,0)$ . Find the perimeter of the triangle. Express your answer in simplest radical form. [The use of the grid below is optional.]

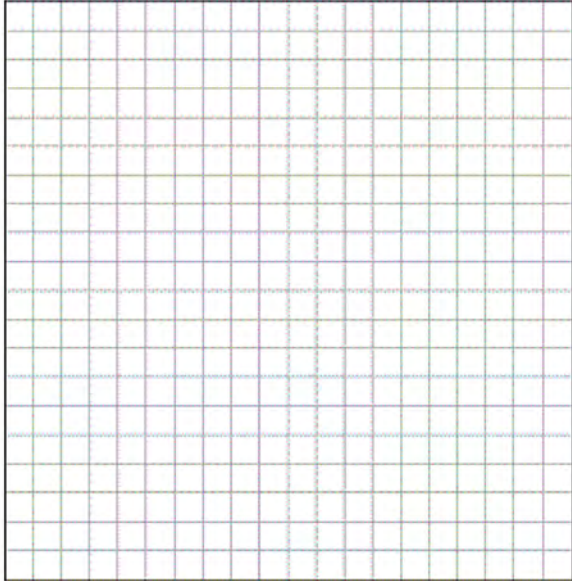

- 37 The coordinates of the vertices of parallelogram  $ABCD$  are  $A(-2,2)$ ,  $B(3,5)$ ,  $C(4,2)$ , and  $D(-1,-1)$ . State the coordinates of the vertices of parallelogram  $A''B''C''D''$  that result from the transformation  $r_{y\text{-axis}} \circ T_{2,-3}$ . [The use of the set of axes below is optional.]

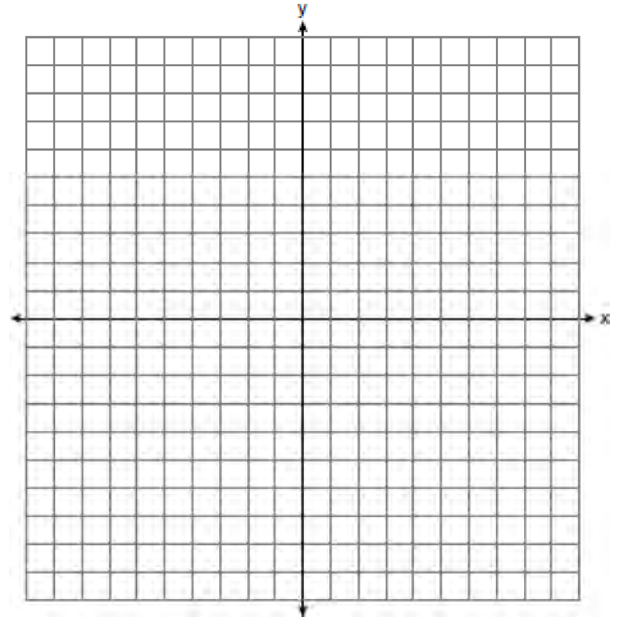

- 38 Given:  $\triangle ABC$  and  $\triangle EDC$ ,  $C$  is the midpoint of  $\overline{BD}$  and  $\overline{AE}$   
 Prove:  $\overline{AB} \parallel \overline{DE}$

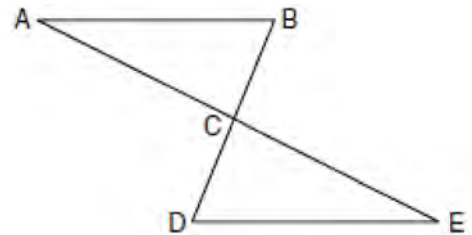

0809ge

- 1 Based on the diagram below, which statement is true?

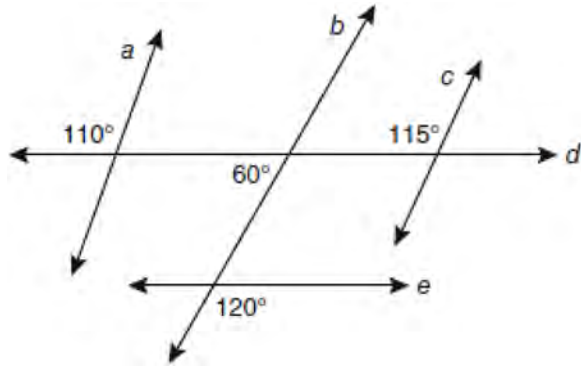

- 1)  $a \parallel b$
- 2)  $a \parallel c$
- 3)  $b \parallel c$
- 4)  $d \parallel e$

- 2 The diagram below shows the construction of the bisector of  $\angle ABC$ .

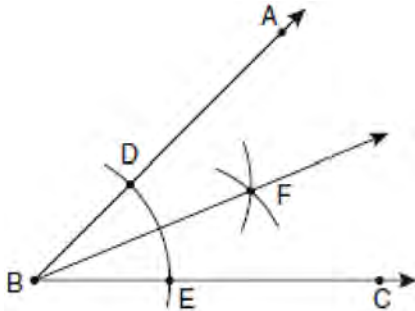

Which statement is *not* true?

- 1)  $m\angle EBF = \frac{1}{2} m\angle ABC$
- 2)  $m\angle DBF = \frac{1}{2} m\angle ABC$
- 3)  $m\angle EBF = m\angle ABC$
- 4)  $m\angle DBF = m\angle EBF$

- 3 In the diagram of  $\triangle ABC$  below,  $\overline{AB} \cong \overline{AC}$ . The measure of  $\angle B$  is  $40^\circ$ .

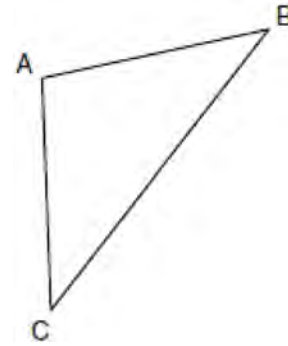

What is the measure of  $\angle A$ ?

- 1)  $40^\circ$
- 2)  $50^\circ$
- 3)  $70^\circ$
- 4)  $100^\circ$

- 4 In the diagram of circle  $O$  below, chord  $\overline{CD}$  is parallel to diameter  $\overline{AOB}$  and  $m\widehat{AC} = 30$ .

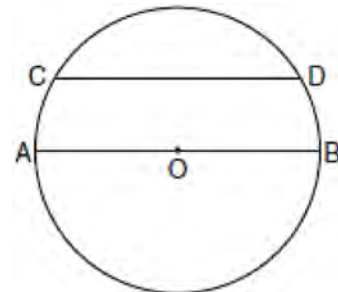

What is  $m\widehat{CD}$ ?

- 1) 150
- 2) 120
- 3) 100
- 4) 60

- 5 In the diagram of trapezoid  $ABCD$  below, diagonals  $\overline{AC}$  and  $\overline{BD}$  intersect at  $E$  and  $\triangle ABC \cong \triangle DCB$ .

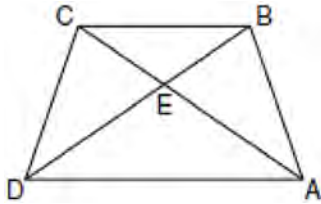

Which statement is true based on the given information?

- 1)  $\overline{AC} \cong \overline{BC}$
  - 2)  $\overline{CD} \cong \overline{AD}$
  - 3)  $\angle CDE \cong \angle BAD$
  - 4)  $\angle CDB \cong \angle BAC$
- 6 Which transformation produces a figure similar but not congruent to the original figure?
- 1)  $T_{1,3}$
  - 2)  $D_{\frac{1}{2}}$
  - 3)  $R_{90^\circ}$
  - 4)  $r_{y=x}$

- 7 In the diagram below of parallelogram  $ABCD$  with diagonals  $\overline{AC}$  and  $\overline{BD}$ ,  $m\angle 1 = 45$  and  $m\angle DCB = 120$ .

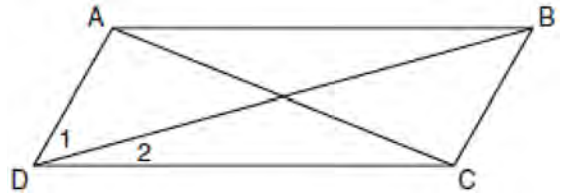

What is the measure of  $\angle 2$ ?

- 1)  $15^\circ$
  - 2)  $30^\circ$
  - 3)  $45^\circ$
  - 4)  $60^\circ$
- 8 On the set of axes below, Geoff drew rectangle  $ABCD$ . He will transform the rectangle by using the translation  $(x,y) \rightarrow (x+2,y+1)$  and then will reflect the translated rectangle over the  $x$ -axis.

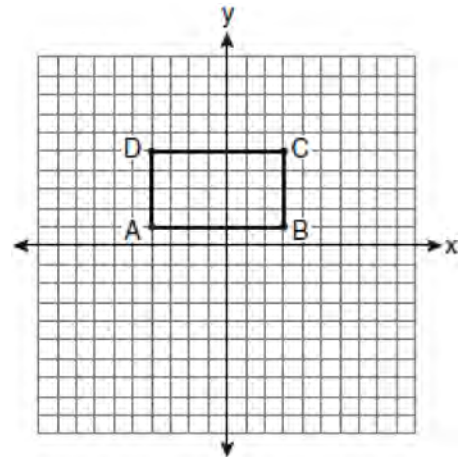

What will be the area of the rectangle after these transformations?

- 1) exactly 28 square units
- 2) less than 28 square units
- 3) greater than 28 square units
- 4) It cannot be determined from the information given.

9 What is the equation of a line that is parallel to the line whose equation is  $y = x + 2$ ?

- 1)  $x + y = 5$
- 2)  $2x + y = -2$
- 3)  $y - x = -1$
- 4)  $y - 2x = 3$

10 The endpoints of  $\overline{CD}$  are  $C(-2, -4)$  and  $D(6, 2)$ .  
What are the coordinates of the midpoint of  $\overline{CD}$ ?

- 1)  $(2, 3)$
- 2)  $(2, -1)$
- 3)  $(4, -2)$
- 4)  $(4, 3)$

11 What are the center and the radius of the circle whose equation is  $(x - 3)^2 + (y + 3)^2 = 36$ ?

- 1) center =  $(3, -3)$ ; radius = 6
- 2) center =  $(-3, 3)$ ; radius = 6
- 3) center =  $(3, -3)$ ; radius = 36
- 4) center =  $(-3, 3)$ ; radius = 36

12 Given the equations:  $y = x^2 - 6x + 10$

$$y + x = 4$$

What is the solution to the given system of equations?

- 1)  $(2, 3)$
- 2)  $(3, 2)$
- 3)  $(2, 2)$  and  $(1, 3)$
- 4)  $(2, 2)$  and  $(3, 1)$

13 The diagonal  $\overline{AC}$  is drawn in parallelogram  $ABCD$ .  
Which method can *not* be used to prove that  $\triangle ABC \cong \triangle CDA$ ?

- 1) SSS
- 2) SAS
- 3) SSA
- 4) ASA

14 In the diagram below, line  $k$  is perpendicular to plane  $\mathcal{P}$  at point  $T$ .

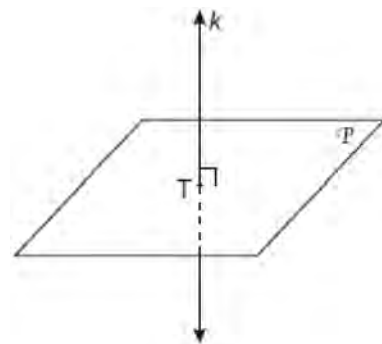

Which statement is true?

- 1) Any point in plane  $\mathcal{P}$  also will be on line  $k$ .
- 2) Only one line in plane  $\mathcal{P}$  will intersect line  $k$ .
- 3) All planes that intersect plane  $\mathcal{P}$  will pass through  $T$ .
- 4) Any plane containing line  $k$  is perpendicular to plane  $\mathcal{P}$ .

- 15 In the diagram below, which transformation was used to map  $\triangle ABC$  to  $\triangle A'B'C'$ ?

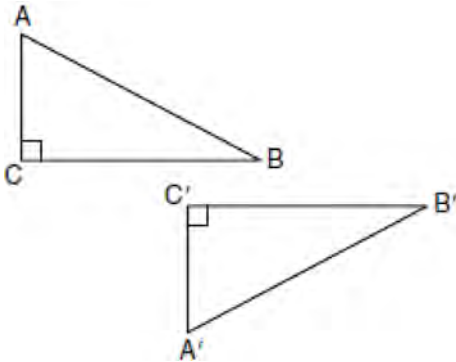

- 1) dilation  
 2) rotation  
 3) reflection  
 4) glide reflection
- 16 Which set of numbers represents the lengths of the sides of a triangle?
- 1) {5, 18, 13}  
 2) {6, 17, 22}  
 3) {16, 24, 7}  
 4) {26, 8, 15}
- 17 What is the slope of a line perpendicular to the line whose equation is  $y = -\frac{2}{3}x - 5$ ?

- 1)  $-\frac{3}{2}$   
 2)  $-\frac{2}{3}$   
 3)  $\frac{2}{3}$   
 4)  $\frac{3}{2}$

- 18 A quadrilateral whose diagonals bisect each other and are perpendicular is a
- 1) rhombus  
 2) rectangle  
 3) trapezoid  
 4) parallelogram

- 19 If the endpoints of  $\overline{AB}$  are  $A(-4, 5)$  and  $B(2, -5)$ , what is the length of  $\overline{AB}$ ?
- 1)  $2\sqrt{34}$   
 2) 2  
 3)  $\sqrt{61}$   
 4) 8

- 20 In the diagram below of  $\triangle ACT$ ,  $D$  is the midpoint of  $\overline{AC}$ ,  $O$  is the midpoint of  $\overline{AT}$ , and  $G$  is the midpoint of  $\overline{CT}$ .

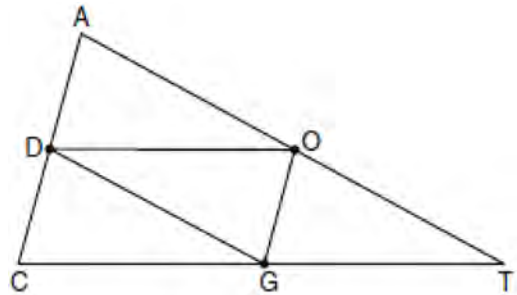

If  $AC = 10$ ,  $AT = 18$ , and  $CT = 22$ , what is the perimeter of parallelogram  $CDOG$ ?

- 1) 21  
 2) 25  
 3) 32  
 4) 40

- 21 Which equation represents circle  $K$  shown in the graph below?

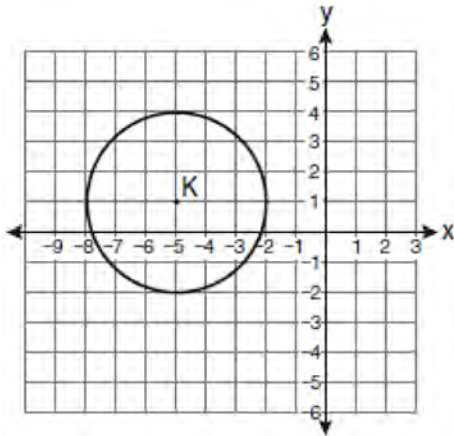

- 1)  $(x+5)^2 + (y-1)^2 = 3$
- 2)  $(x+5)^2 + (y-1)^2 = 9$
- 3)  $(x-5)^2 + (y+1)^2 = 3$
- 4)  $(x-5)^2 + (y+1)^2 = 9$

- 22 In the diagram below of right triangle  $ACB$ , altitude  $CD$  is drawn to hypotenuse  $AB$ .

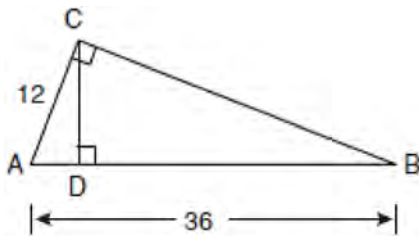

If  $AB = 36$  and  $AC = 12$ , what is the length of  $\overline{AD}$ ?

- 1) 32
- 2) 6
- 3) 3
- 4) 4

- 23 In the diagram of circle  $O$  below, chord  $\overline{AB}$  intersects chord  $\overline{CD}$  at  $E$ ,  $DE = 2x + 8$ ,  $EC = 3$ ,  $AE = 4x - 3$ , and  $EB = 4$ .

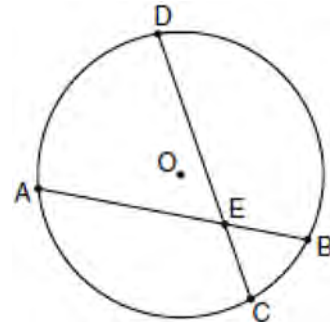

What is the value of  $x$ ?

- 1) 1
- 2) 3.6
- 3) 5
- 4) 10.25

- 24 What is the negation of the statement “Squares are parallelograms”?

- 1) Parallelograms are squares.
- 2) Parallelograms are not squares.
- 3) It is not the case that squares are parallelograms.
- 4) It is not the case that parallelograms are squares.

- 25 The diagram below shows the construction of the center of the circle circumscribed about  $\triangle ABC$ .

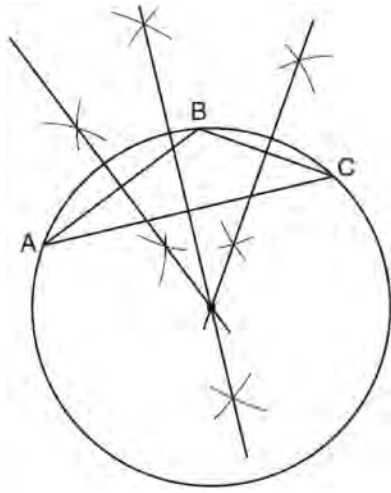

This construction represents how to find the intersection of

- 1) the angle bisectors of  $\triangle ABC$
  - 2) the medians to the sides of  $\triangle ABC$
  - 3) the altitudes to the sides of  $\triangle ABC$
  - 4) the perpendicular bisectors of the sides of  $\triangle ABC$
- 26 A right circular cylinder has a volume of 1,000 cubic inches and a height of 8 inches. What is the radius of the cylinder to the nearest tenth of an inch?
- 1) 6.3
  - 2) 11.2
  - 3) 19.8
  - 4) 39.8
- 27 If two different lines are perpendicular to the same plane, they are
- 1) collinear
  - 2) coplanar
  - 3) congruent
  - 4) consecutive

- 28 How many common tangent lines can be drawn to the two externally tangent circles shown below?

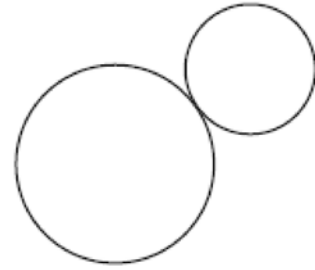

- 1) 1
  - 2) 2
  - 3) 3
  - 4) 4
- 29 In the diagram below of isosceles trapezoid  $DEFG$ ,  $\overline{DE} \parallel \overline{GF}$ ,  $DE = 4x - 2$ ,  $EF = 3x + 2$ ,  $FG = 5x - 3$ , and  $GD = 2x + 5$ . Find the value of  $x$ .

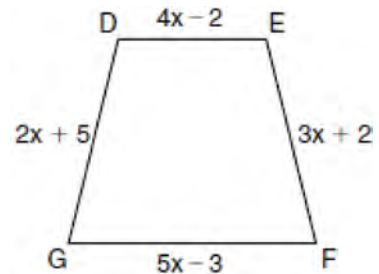

- 30 A regular pyramid with a square base is shown in the diagram below.

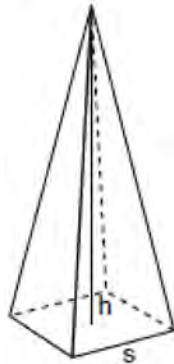

A side,  $s$ , of the base of the pyramid is 12 meters, and the height,  $h$ , is 42 meters. What is the volume of the pyramid in cubic meters?

- 31 Write an equation of the line that passes through the point  $(6, -5)$  and is parallel to the line whose equation is  $2x - 3y = 11$ .

- 32 Using a compass and straightedge, construct the angle bisector of  $\angle ABC$  shown below. [Leave all construction marks.]

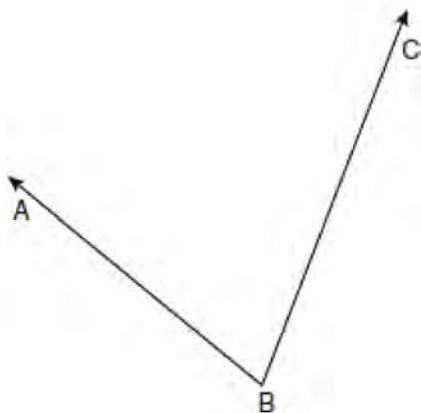

- 33 The degree measures of the angles of  $\triangle ABC$  are represented by  $x$ ,  $3x$ , and  $5x - 54$ . Find the value of  $x$ .

- 34 In the diagram below of  $\triangle ABC$  with side  $\overline{AC}$  extended through  $D$ ,  $m\angle A = 37$  and  $m\angle BCD = 117$ . Which side of  $\triangle ABC$  is the longest side? Justify your answer.

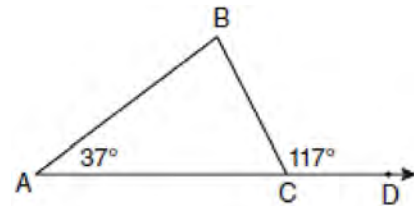

(Not drawn to scale)

- 35 Write an equation of the perpendicular bisector of the line segment whose endpoints are  $(-1, 1)$  and  $(7, -5)$ . [The use of the grid below is optional]

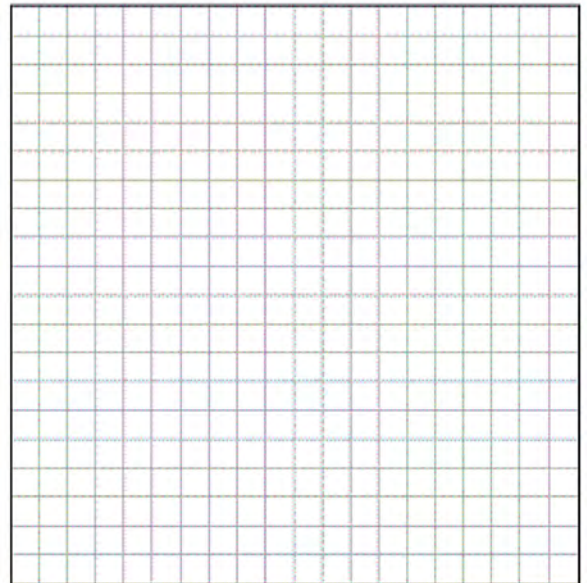



- 36 On the set of axes below, sketch the points that are 5 units from the origin and sketch the points that are 2 units from the line  $y = 3$ . Label with an **X** all points that satisfy both conditions.

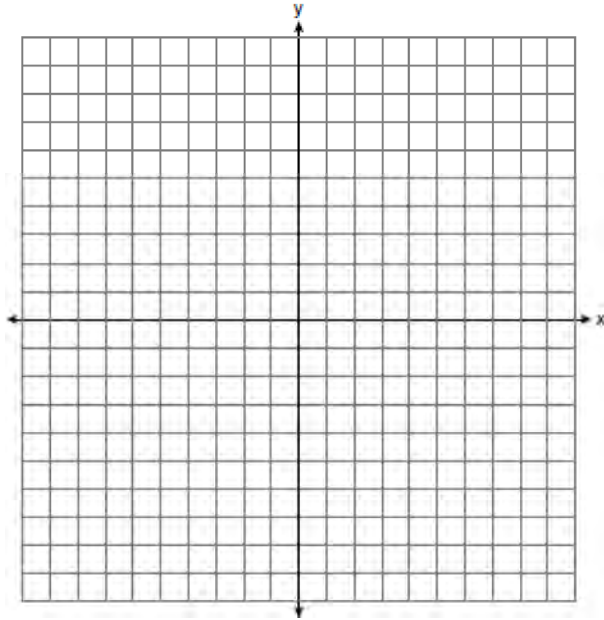

- 37 Triangle  $DEG$  has the coordinates  $D(1,1)$ ,  $E(5,1)$ , and  $G(5,4)$ . Triangle  $DEG$  is rotated  $90^\circ$  about the origin to form  $\triangle D'E'G'$ . On the grid below, graph and label  $\triangle DEG$  and  $\triangle D'E'G'$ . State the coordinates of the vertices  $D'$ ,  $E'$ , and  $G'$ . Justify that this transformation preserves distance.

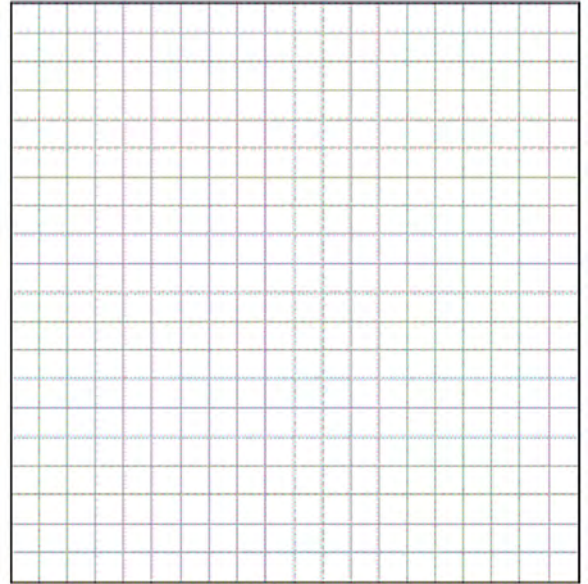

- 38 Given: Quadrilateral  $ABCD$ , diagonal  $\overline{AFEC}$ ,  $\overline{AE} \cong \overline{FC}$ ,  $\overline{BF} \perp \overline{AC}$ ,  $\overline{DE} \perp \overline{AC}$ ,  $\angle 1 \cong \angle 2$   
 Prove:  $ABCD$  is a parallelogram.

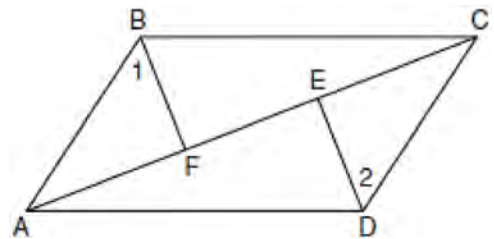

**0110ge**

- 1 In the diagram below of trapezoid  $RSUT$ ,  $\overline{RS} \parallel \overline{TU}$ ,  $X$  is the midpoint of  $\overline{RT}$ , and  $V$  is the midpoint of  $\overline{SU}$ .

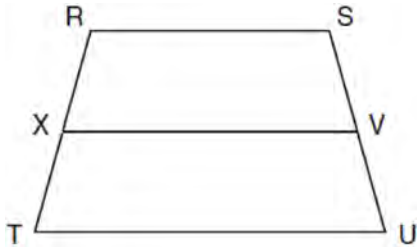

If  $RS = 30$  and  $XV = 44$ , what is the length of  $\overline{TU}$ ?

- 1) 37
  - 2) 58
  - 3) 74
  - 4) 118
- 2 In  $\triangle ABC$ ,  $m\angle A = x$ ,  $m\angle B = 2x + 2$ , and  $m\angle C = 3x + 4$ . What is the value of  $x$ ?
- 1) 29
  - 2) 31
  - 3) 59
  - 4) 61

- 3 Which expression best describes the transformation shown in the diagram below?

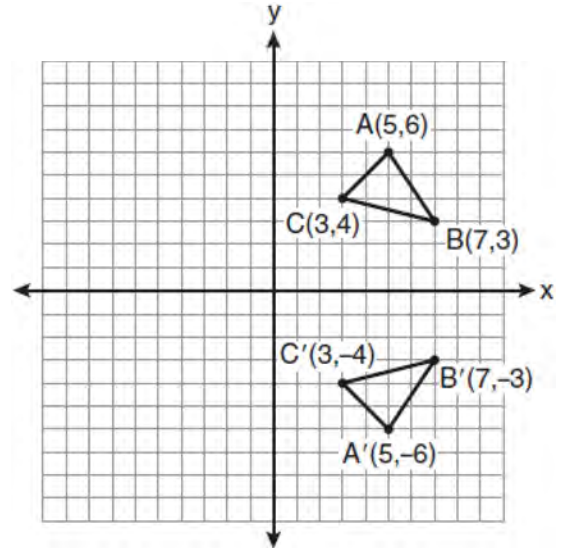

- 1) same orientation; reflection
- 2) opposite orientation; reflection
- 3) same orientation; translation
- 4) opposite orientation; translation

- 4 Based on the construction below, which statement must be true?

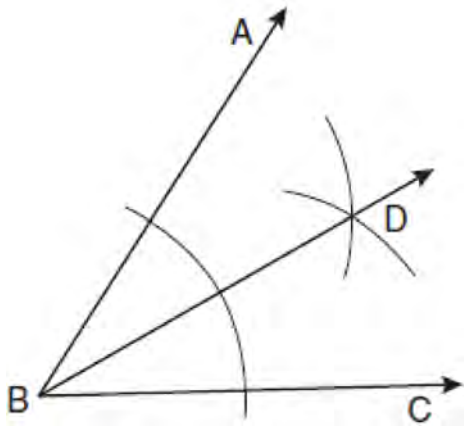

- 1)  $m\angle ABD = \frac{1}{2} m\angle CBD$
- 2)  $m\angle ABD = m\angle CBD$
- 3)  $m\angle ABD = m\angle ABC$
- 4)  $m\angle CBD = \frac{1}{2} m\angle ABD$

- 5 In the diagram below,  $\triangle ABC$  is inscribed in circle  $P$ . The distances from the center of circle  $P$  to each side of the triangle are shown.

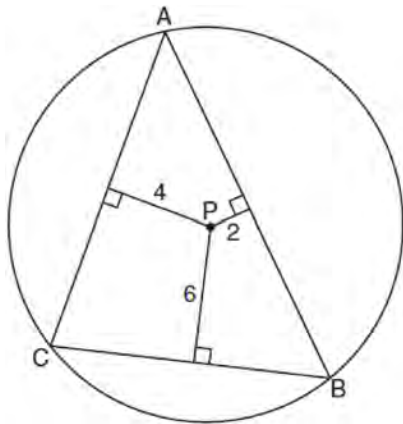

Which statement about the sides of the triangle is true?

- 1)  $AB > AC > BC$
- 2)  $AB < AC$  and  $AC > BC$
- 3)  $AC > AB > BC$
- 4)  $AC = AB$  and  $AB > BC$

- 6 Which transformation is *not* always an isometry?
- 1) rotation
  - 2) dilation
  - 3) reflection
  - 4) translation

- 7 In  $\triangle ABC$ ,  $\overline{AB} \cong \overline{BC}$ . An altitude is drawn from  $B$  to  $\overline{AC}$  and intersects  $\overline{AC}$  at  $D$ . Which conclusion is *not* always true?

- 1)  $\angle ABD \cong \angle CBD$
- 2)  $\angle BDA \cong \angle BDC$
- 3)  $\overline{AD} \cong \overline{BD}$
- 4)  $\overline{AD} \cong \overline{DC}$

- 8 In the diagram below, tangent  $\overline{PA}$  and secant  $\overline{PBC}$  are drawn to circle  $O$  from external point  $P$ .

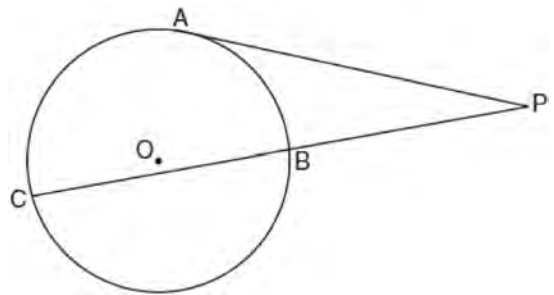

If  $PB = 4$  and  $BC = 5$ , what is the length of  $\overline{PA}$ ?

- 1) 20
- 2) 9
- 3) 8
- 4) 6

- 9 Which geometric principle is used to justify the construction below?

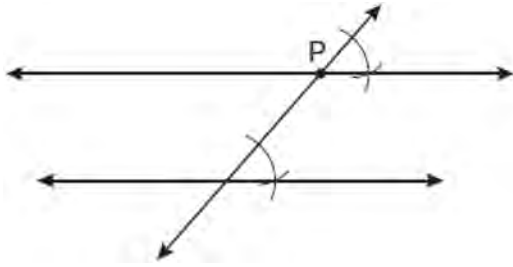

- 1) A line perpendicular to one of two parallel lines is perpendicular to the other.
  - 2) Two lines are perpendicular if they intersect to form congruent adjacent angles.
  - 3) When two lines are intersected by a transversal and alternate interior angles are congruent, the lines are parallel.
  - 4) When two lines are intersected by a transversal and the corresponding angles are congruent, the lines are parallel.
- 10 Which equation represents the circle whose center is  $(-2, 3)$  and whose radius is 5?
- 1)  $(x - 2)^2 + (y + 3)^2 = 5$
  - 2)  $(x + 2)^2 + (y - 3)^2 = 5$
  - 3)  $(x + 2)^2 + (y - 3)^2 = 25$
  - 4)  $(x - 2)^2 + (y + 3)^2 = 25$
- 11 Towns  $A$  and  $B$  are 16 miles apart. How many points are 10 miles from town  $A$  and 12 miles from town  $B$ ?
- 1) 1
  - 2) 2
  - 3) 3
  - 4) 0

- 12 Lines  $j$  and  $k$  intersect at point  $P$ . Line  $m$  is drawn so that it is perpendicular to lines  $j$  and  $k$  at point  $P$ . Which statement is correct?
- 1) Lines  $j$  and  $k$  are in perpendicular planes.
  - 2) Line  $m$  is in the same plane as lines  $j$  and  $k$ .
  - 3) Line  $m$  is parallel to the plane containing lines  $j$  and  $k$ .
  - 4) Line  $m$  is perpendicular to the plane containing lines  $j$  and  $k$ .

- 13 In the diagram below of parallelogram  $STUV$ ,  $SV = x + 3$ ,  $VU = 2x - 1$ , and  $TU = 4x - 3$ .

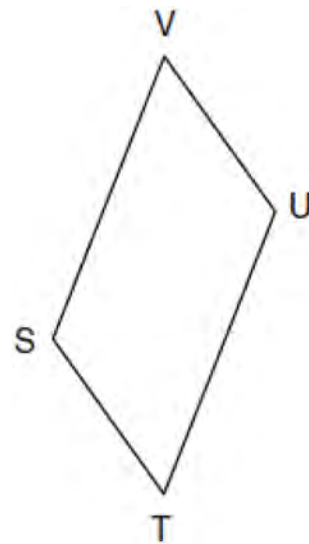

What is the length of  $\overline{SV}$ ?

- 1) 5
  - 2) 2
  - 3) 7
  - 4) 4
- 14 Which equation represents a line parallel to the line whose equation is  $2y - 5x = 10$ ?
- 1)  $5y - 2x = 25$
  - 2)  $5y + 2x = 10$
  - 3)  $4y - 10x = 12$
  - 4)  $2y + 10x = 8$

- 15 In the diagram below of circle  $O$ , chords  $\overline{AD}$  and  $\overline{BC}$  intersect at  $E$ ,  $m\widehat{AC} = 87$ , and  $m\widehat{BD} = 35$ .

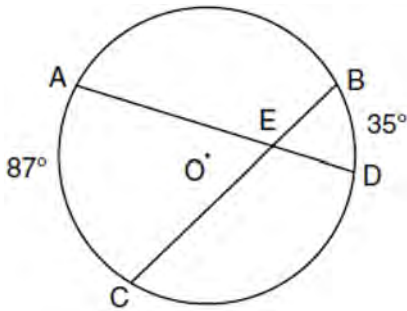

What is the degree measure of  $\angle CEA$ ?

- 1) 87
  - 2) 61
  - 3) 43.5
  - 4) 26
- 16 In the diagram below of  $\triangle ADB$ ,  $m\angle BDA = 90$ ,  $AD = 5\sqrt{2}$ , and  $AB = 2\sqrt{15}$ .

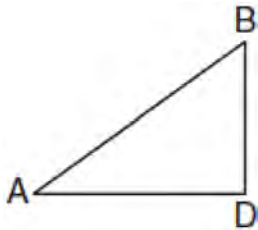

What is the length of  $\overline{BD}$ ?

- 1)  $\sqrt{10}$
  - 2)  $\sqrt{20}$
  - 3)  $\sqrt{50}$
  - 4)  $\sqrt{110}$
- 17 What is the distance between the points  $(-3,2)$  and  $(1,0)$ ?
- 1)  $2\sqrt{2}$
  - 2)  $2\sqrt{3}$
  - 3)  $5\sqrt{2}$
  - 4)  $2\sqrt{5}$

- 18 What is an equation of the line that contains the point  $(3,-1)$  and is perpendicular to the line whose equation is  $y = -3x + 2$ ?

- 1)  $y = -3x + 8$
- 2)  $y = -3x$
- 3)  $y = \frac{1}{3}x$
- 4)  $y = \frac{1}{3}x - 2$

- 19 In the diagram below,  $\overline{SQ}$  and  $\overline{PR}$  intersect at  $T$ ,  $\overline{PQ}$  is drawn, and  $\overline{PS} \parallel \overline{QR}$ .

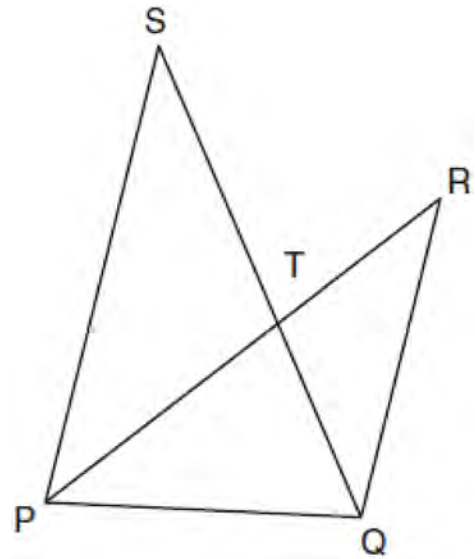

What technique can be used to prove that  $\triangle PST \sim \triangle RQT$ ?

- 1) SAS
- 2) SSS
- 3) ASA
- 4) AA

- 20 The equation of a circle is  $(x - 2)^2 + (y + 4)^2 = 4$ . Which diagram is the graph of the circle?

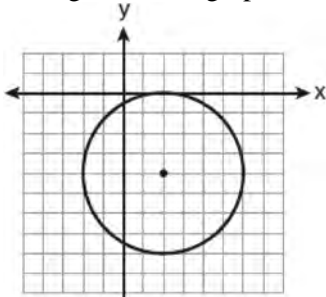

1)

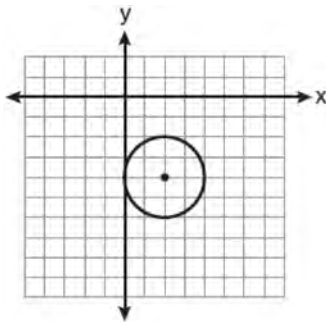

2)

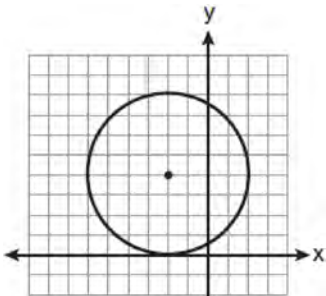

3)

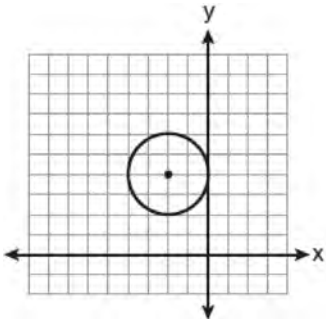

4)

- 21 In the diagram below,  $\triangle ABC$  is shown with  $\overline{AC}$  extended through point  $D$ .

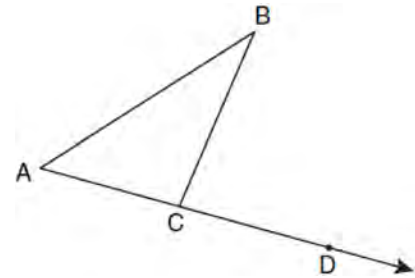

If  $m\angle BCD = 6x + 2$ ,  $m\angle BAC = 3x + 15$ , and  $m\angle ABC = 2x - 1$ , what is the value of  $x$ ?

- 1) 12
  - 2)  $14\frac{10}{11}$
  - 3) 16
  - 4)  $18\frac{1}{9}$
- 22 Given  $\triangle ABC \sim \triangle DEF$  such that  $\frac{AB}{DE} = \frac{3}{2}$ . Which statement is *not* true?
- 1)  $\frac{BC}{EF} = \frac{3}{2}$
  - 2)  $\frac{m\angle A}{m\angle D} = \frac{3}{2}$
  - 3)  $\frac{\text{area of } \triangle ABC}{\text{area of } \triangle DEF} = \frac{9}{4}$
  - 4)  $\frac{\text{perimeter of } \triangle ABC}{\text{perimeter of } \triangle DEF} = \frac{3}{2}$

- 23 The pentagon in the diagram below is formed by five rays.

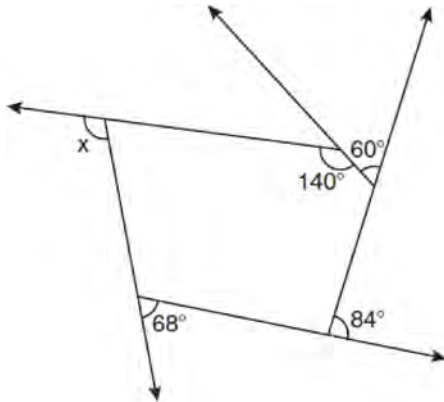

What is the degree measure of angle  $x$ ?

- 1) 72
  - 2) 96
  - 3) 108
  - 4) 112
- 24 Through a given point,  $P$ , on a plane, how many lines can be drawn that are perpendicular to that plane?
- 1) 1
  - 2) 2
  - 3) more than 2
  - 4) none
- 25 What is the slope of a line that is perpendicular to the line whose equation is  $3x + 4y = 12$ ?
- 1)  $\frac{3}{4}$
  - 2)  $-\frac{3}{4}$
  - 3)  $\frac{4}{3}$
  - 4)  $-\frac{4}{3}$

- 26 What is the image of point  $A(4,2)$  after the composition of transformations defined by  $R_{90^\circ} \circ r_{y=x}$ ?

- 1)  $(-4,2)$
- 2)  $(4,-2)$
- 3)  $(-4,-2)$
- 4)  $(2,-4)$

- 27 Which expression represents the volume, in cubic centimeters, of the cylinder represented in the diagram below?

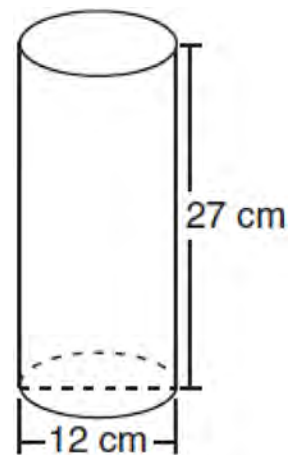

- 1)  $162\pi$
  - 2)  $324\pi$
  - 3)  $972\pi$
  - 4)  $3,888\pi$
- 28 What is the inverse of the statement “If two triangles are not similar, their corresponding angles are not congruent”?
- 1) If two triangles are similar, their corresponding angles are not congruent.
  - 2) If corresponding angles of two triangles are not congruent, the triangles are not similar.
  - 3) If two triangles are similar, their corresponding angles are congruent.
  - 4) If corresponding angles of two triangles are congruent, the triangles are similar.

29 In  $\triangle RST$ ,  $m\angle RST = 46$  and  $\overline{RS} \cong \overline{ST}$ . Find  $m\angle STR$ .

30 Tim has a rectangular prism with a length of 10 centimeters, a width of 2 centimeters, and an unknown height. He needs to build another rectangular prism with a length of 5 centimeters and the same height as the original prism. The volume of the two prisms will be the same. Find the width, in centimeters, of the new prism.

31 In the diagram below of circle  $C$ ,  $\overline{QR}$  is a diameter, and  $Q(1,8)$  and  $C(3.5,2)$  are points on a coordinate plane. Find and state the coordinates of point  $R$ .

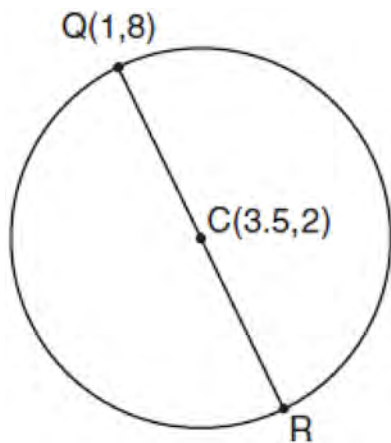

32 Using a compass and straightedge, and  $\overline{AB}$  below, construct an equilateral triangle with all sides congruent to  $\overline{AB}$ . [Leave all construction marks.]



33 In the diagram below of  $\triangle ACD$ ,  $E$  is a point on  $\overline{AD}$  and  $B$  is a point on  $\overline{AC}$ , such that  $\overline{EB} \parallel \overline{DC}$ . If  $\overline{AE} = 3$ ,  $\overline{ED} = 6$ , and  $\overline{DC} = 15$ , find the length of  $\overline{EB}$ .

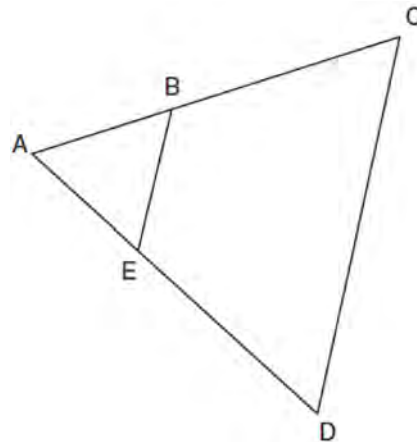

34 In the diagram below of  $\triangle TEM$ , medians  $\overline{TB}$ ,  $\overline{EC}$ , and  $\overline{MA}$  intersect at  $D$ , and  $\overline{TB} = 9$ . Find the length of  $\overline{TD}$ .

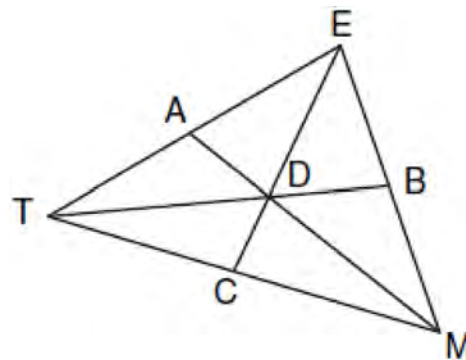

35 In  $\triangle KLM$ ,  $m\angle K = 36$  and  $\overline{KM} = 5$ . The transformation  $D_2$  is performed on  $\triangle KLM$  to form  $\triangle K'L'M'$ . Find  $m\angle K'$ . Justify your answer. Find the length of  $\overline{K'M'}$ . Justify your answer.



36 Given:  $\overline{JKLM}$  is a parallelogram.

$$\overline{JM} \cong \overline{LN}$$

$$\angle LMN \cong \angle LNM$$

Prove:  $\overline{JKLM}$  is a rhombus.

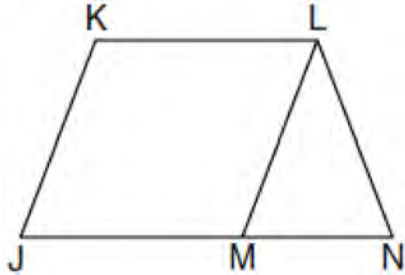

37 On the grid below, graph the points that are equidistant from both the  $x$  and  $y$  axes and the points that are 5 units from the origin. Label with an **X** all points that satisfy both conditions.

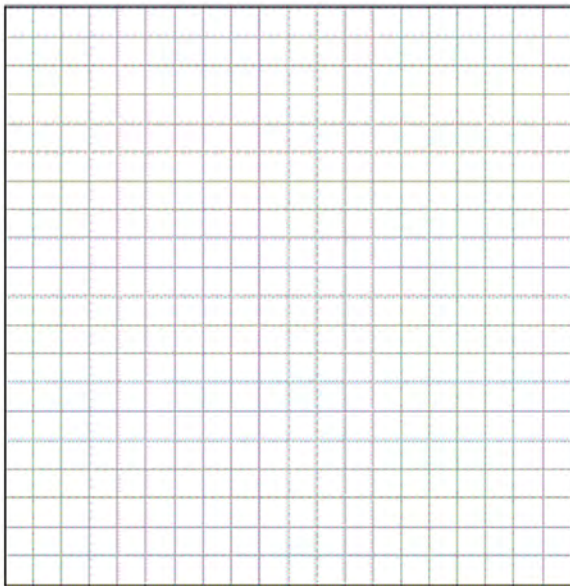

38 On the set of axes below, solve the following system of equations graphically for all values of  $x$  and  $y$ .

$$y = (x - 2)^2 + 4$$

$$4x + 2y = 14$$

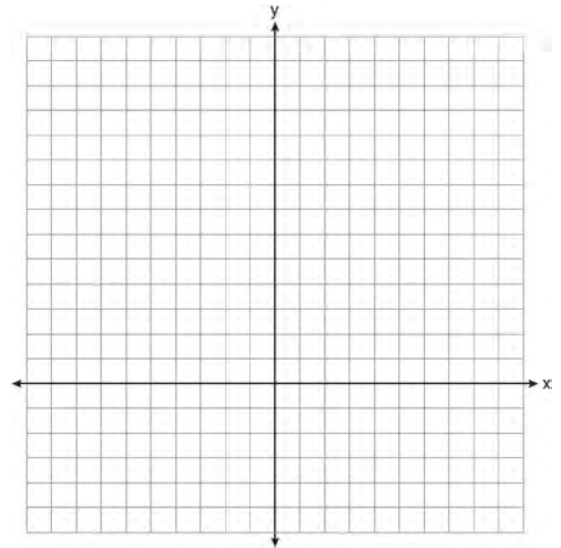

0610ge

- 1 In the diagram below of circle  $O$ , chord  $\overline{AB} \parallel$  chord  $\overline{CD}$ , and chord  $\overline{CD} \parallel$  chord  $\overline{EF}$ .

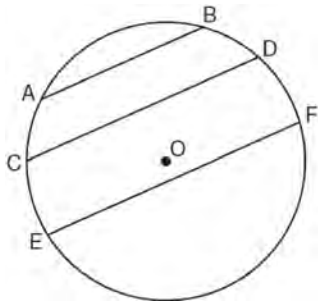

Which statement must be true?

- 1)  $\widehat{CE} \cong \widehat{DF}$
  - 2)  $\widehat{AC} \cong \widehat{DF}$
  - 3)  $\widehat{AC} \cong \widehat{CE}$
  - 4)  $\widehat{EF} \cong \widehat{CD}$
- 2 What is the negation of the statement “I am not going to eat ice cream”?
- 1) I like ice cream.
  - 2) I am going to eat ice cream.
  - 3) If I eat ice cream, then I like ice cream.
  - 4) If I don’t like ice cream, then I don’t eat ice cream.

- 3 The diagram below shows a right pentagonal prism.

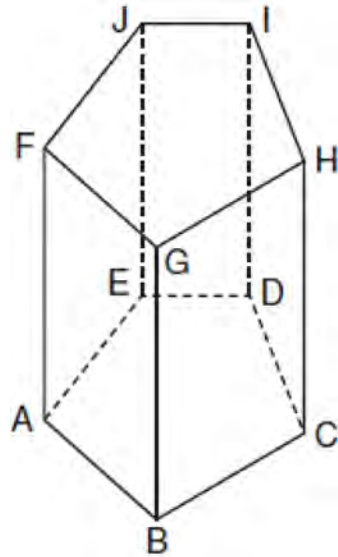

Which statement is always true?

- 1)  $\overline{BC} \parallel \overline{ED}$
  - 2)  $\overline{FG} \parallel \overline{CD}$
  - 3)  $\overline{FJ} \parallel \overline{IH}$
  - 4)  $\overline{GB} \parallel \overline{HC}$
- 4 In isosceles triangle  $ABC$ ,  $AB = BC$ . Which statement will always be true?
- 1)  $m\angle B = m\angle A$
  - 2)  $m\angle A > m\angle B$
  - 3)  $m\angle A = m\angle C$
  - 4)  $m\angle C < m\angle B$

- 5 The rectangle  $ABCD$  shown in the diagram below will be reflected across the  $x$ -axis.

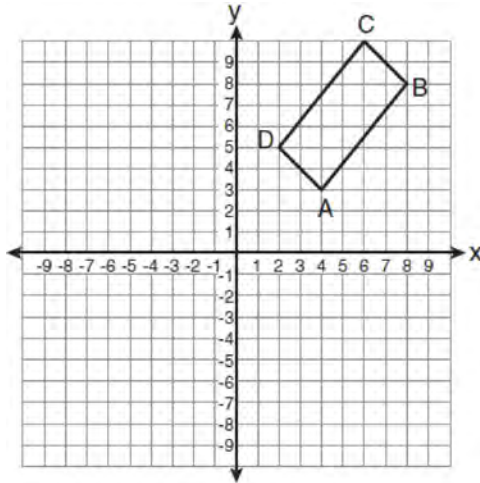

What will *not* be preserved?

- 1) slope of  $\overline{AB}$
  - 2) parallelism of  $\overline{AB}$  and  $\overline{CD}$
  - 3) length of  $\overline{AB}$
  - 4) measure of  $\angle A$
- 6 A right circular cylinder has an altitude of 11 feet and a radius of 5 feet. What is the lateral area, in square feet, of the cylinder, to the *nearest tenth*?
- 1) 172.7
  - 2) 172.8
  - 3) 345.4
  - 4) 345.6
- 7 A transversal intersects two lines. Which condition would always make the two lines parallel?
- 1) Vertical angles are congruent.
  - 2) Alternate interior angles are congruent.
  - 3) Corresponding angles are supplementary.
  - 4) Same-side interior angles are complementary.

- 8 If the diagonals of a quadrilateral do *not* bisect each other, then the quadrilateral could be a
- 1) rectangle
  - 2) rhombus
  - 3) square
  - 4) trapezoid
- 9 What is the converse of the statement "If Bob does his homework, then George gets candy"?
- 1) If George gets candy, then Bob does his homework.
  - 2) Bob does his homework if and only if George gets candy.
  - 3) If George does not get candy, then Bob does not do his homework.
  - 4) If Bob does not do his homework, then George does not get candy.
- 10 In  $\triangle PQR$ ,  $PQ = 8$ ,  $QR = 12$ , and  $RP = 13$ . Which statement about the angles of  $\triangle PQR$  must be true?
- 1)  $m\angle Q > m\angle P > m\angle R$
  - 2)  $m\angle Q > m\angle R > m\angle P$
  - 3)  $m\angle R > m\angle P > m\angle Q$
  - 4)  $m\angle P > m\angle R > m\angle Q$

11 Given:  $y = \frac{1}{4}x - 3$

$$y = x^2 + 8x + 12$$

In which quadrant will the graphs of the given equations intersect?

- 1) I
- 2) II
- 3) III
- 4) IV

- 12 Which diagram shows the construction of an equilateral triangle?

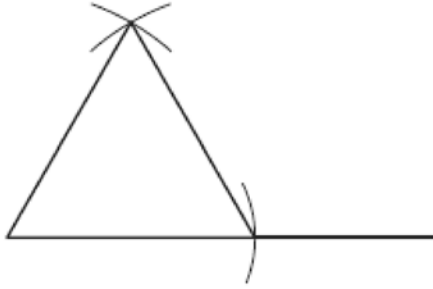

1)

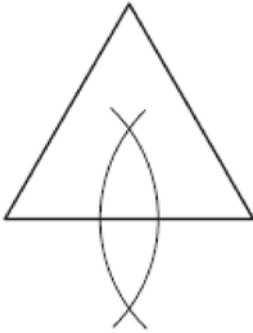

2)

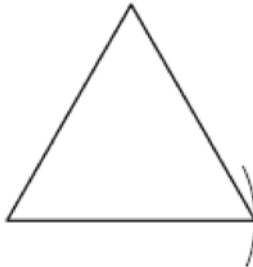

3)

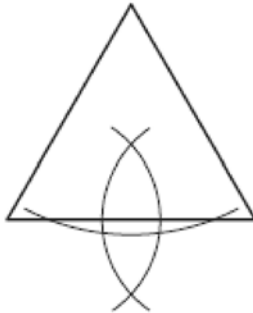

4)

- 13 Line segment  $AB$  is tangent to circle  $O$  at  $A$ . Which type of triangle is always formed when points  $A$ ,  $B$ , and  $O$  are connected?

- 1) right
- 2) obtuse
- 3) scalene
- 4) isosceles

- 14 What is an equation for the circle shown in the graph below?

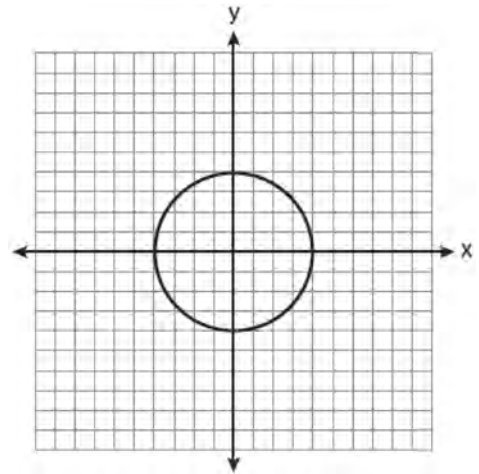

- 1)  $x^2 + y^2 = 2$
- 2)  $x^2 + y^2 = 4$
- 3)  $x^2 + y^2 = 8$
- 4)  $x^2 + y^2 = 16$

- 15 Which transformation can map the letter **S** onto itself?

- 1) glide reflection
- 2) translation
- 3) line reflection
- 4) rotation

16 In isosceles trapezoid  $ABCD$ ,  $\overline{AB} \cong \overline{CD}$ . If  $BC = 20$ ,  $AD = 36$ , and  $AB = 17$ , what is the length of the altitude of the trapezoid?

- 1) 10
- 2) 12
- 3) 15
- 4) 16

17 In plane  $\mathcal{P}$ , lines  $m$  and  $n$  intersect at point  $A$ . If line  $k$  is perpendicular to line  $m$  and line  $n$  at point  $A$ , then line  $k$  is

- 1) contained in plane  $\mathcal{P}$
- 2) parallel to plane  $\mathcal{P}$
- 3) perpendicular to plane  $\mathcal{P}$
- 4) skew to plane  $\mathcal{P}$

18 The diagram below shows  $\overline{AB}$  and  $\overline{DE}$ .

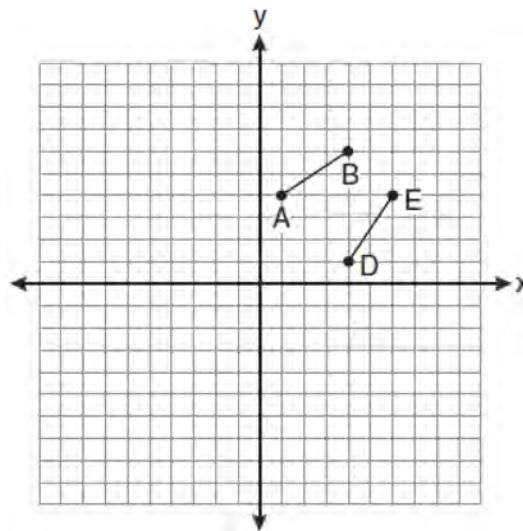

Which transformation will move  $\overline{AB}$  onto  $\overline{DE}$  such that point  $D$  is the image of point  $A$  and point  $E$  is the image of point  $B$ ?

- 1)  $T_{3,-3}$
- 2)  $D_{\frac{1}{2}}$
- 3)  $R_{90^\circ}$
- 4)  $r_{y=x}$

- 19 In the diagram below of circle  $O$ , chords  $\overline{AE}$  and  $\overline{DC}$  intersect at point  $B$ , such that  $m\widehat{AC} = 36$  and  $m\widehat{DE} = 20$ .

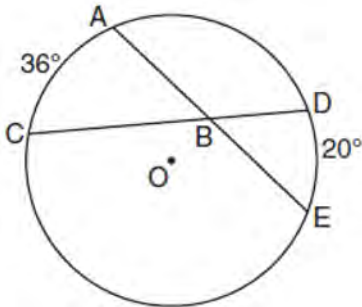

What is  $m\angle ABC$ ?

- 1) 56
- 2) 36
- 3) 28
- 4) 8

- 20 The diagram below shows the construction of a line through point  $P$  perpendicular to line  $m$ .

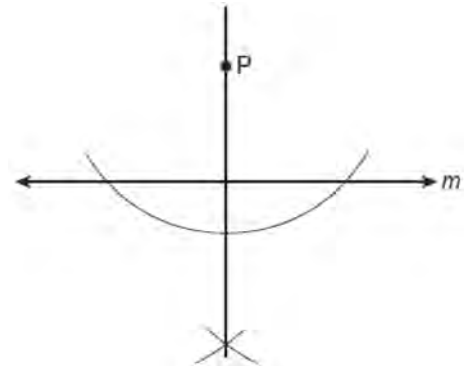

Which statement is demonstrated by this construction?

- 1) If a line is parallel to a line that is perpendicular to a third line, then the line is also perpendicular to the third line.
  - 2) The set of points equidistant from the endpoints of a line segment is the perpendicular bisector of the segment.
  - 3) Two lines are perpendicular if they are equidistant from a given point.
  - 4) Two lines are perpendicular if they intersect to form a vertical line.
- 21 What is the length, to the *nearest tenth*, of the line segment joining the points  $(-4, 2)$  and  $(146, 52)$ ?
- 1) 141.4
  - 2) 150.5
  - 3) 151.9
  - 4) 158.1
- 22 What is the slope of a line perpendicular to the line whose equation is  $y = 3x + 4$ ?
- 1)  $\frac{1}{3}$
  - 2)  $-\frac{1}{3}$
  - 3) 3
  - 4) -3

- 23 In the diagram below of circle  $O$ , secant  $\overline{AB}$  intersects circle  $O$  at  $D$ , secant  $\overline{AOC}$  intersects circle  $O$  at  $E$ ,  $AE = 4$ ,  $AB = 12$ , and  $DB = 6$ .

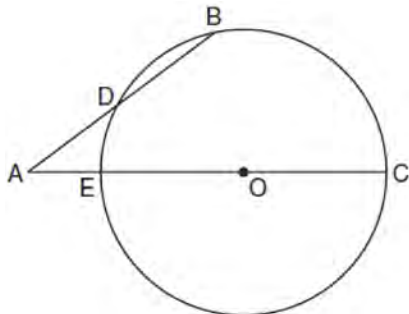

(Not drawn to scale)

What is the length of  $\overline{OC}$ ?

- 1) 4.5
  - 2) 7
  - 3) 9
  - 4) 14
- 24 The diagram below shows a pennant in the shape of an isosceles triangle. The equal sides each measure 13, the altitude is  $x + 7$ , and the base is  $2x$ .

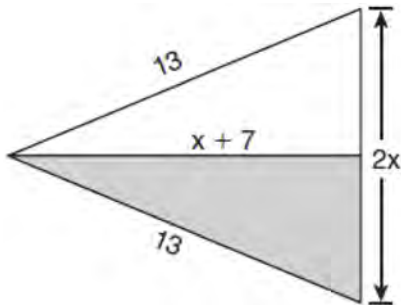

What is the length of the base?

- 1) 5
- 2) 10
- 3) 12
- 4) 24

- 25 In the diagram below of  $\triangle ABC$ ,  $\overline{CD}$  is the bisector of  $\angle BCA$ ,  $\overline{AE}$  is the bisector of  $\angle CAB$ , and  $\overline{BG}$  is drawn.

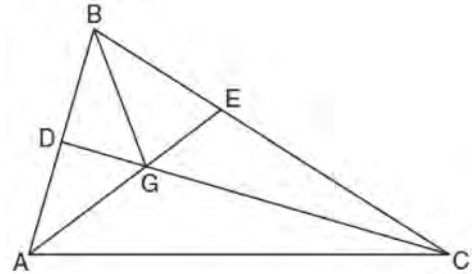

Which statement must be true?

- 1)  $DG = EG$
  - 2)  $AG = BG$
  - 3)  $\angle AEB \cong \angle AEC$
  - 4)  $\angle DBG \cong \angle EBG$
- 26 In the diagram below of circle  $O$ , chords  $\overline{AD}$  and  $\overline{BC}$  intersect at  $E$ .

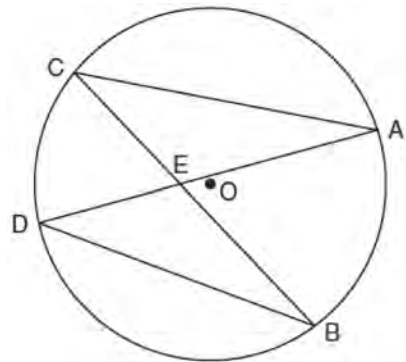

Which relationship must be true?

- 1)  $\triangle CAE \cong \triangle DBE$
- 2)  $\triangle AEC \sim \triangle BED$
- 3)  $\angle ACB \cong \angle CBD$
- 4)  $\widehat{CA} \cong \widehat{DB}$

- 27 Two lines are represented by the equations  $-\frac{1}{2}y = 6x + 10$  and  $y = mx$ . For which value of  $m$  will the lines be parallel?
- 1)  $-12$
  - 2)  $-3$
  - 3)  $3$
  - 4)  $12$

- 28 The coordinates of the vertices of parallelogram  $ABCD$  are  $A(-3,2)$ ,  $B(-2,-1)$ ,  $C(4,1)$ , and  $D(3,4)$ . The slopes of which line segments could be calculated to show that  $ABCD$  is a rectangle?
- 1)  $\overline{AB}$  and  $\overline{DC}$
  - 2)  $\overline{AB}$  and  $\overline{BC}$
  - 3)  $\overline{AD}$  and  $\overline{BC}$
  - 4)  $\overline{AC}$  and  $\overline{BD}$

- 29 Tim is going to paint a wooden sphere that has a diameter of 12 inches. Find the surface area of the sphere, to the nearest square inch.

- 30 In the diagram below of  $\triangle ABC$ ,  $\overline{DE}$  is a midsegment of  $\triangle ABC$ ,  $DE = 7$ ,  $AB = 10$ , and  $BC = 13$ . Find the perimeter of  $\triangle ABC$ .

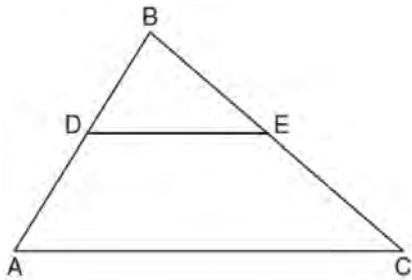

- 31 In right  $\triangle DEF$ ,  $m\angle D = 90$  and  $m\angle F$  is 12 degrees less than twice  $m\angle E$ . Find  $m\angle E$ .

- 32 Triangle  $XYZ$ , shown in the diagram below, is reflected over the line  $x = 2$ . State the coordinates of  $\triangle X'Y'Z'$ , the image of  $\triangle XYZ$ .

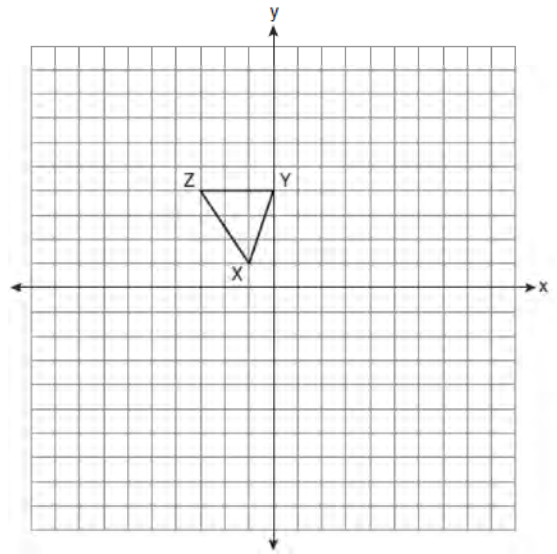

- 33 Two lines,  $\overleftrightarrow{AB}$  and  $\overleftrightarrow{CRD}$ , are parallel and 10 inches apart. Sketch the locus of all points that are equidistant from  $\overleftrightarrow{AB}$  and  $\overleftrightarrow{CRD}$  and 7 inches from point  $R$ . Label with an  $X$  each point that satisfies both conditions.

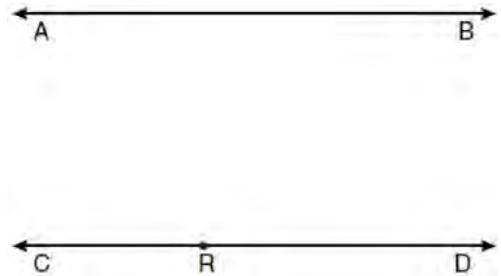



34 The base of a pyramid is a rectangle with a width of 6 cm and a length of 8 cm. Find, in centimeters, the height of the pyramid if the volume is  $288 \text{ cm}^3$ .

35 Given: Quadrilateral  $ABCD$  with  $\overline{AB} \cong \overline{CD}$ ,  $\overline{AD} \cong \overline{BC}$ , and diagonal  $\overline{BD}$  is drawn  
 Prove:  $\angle BDC \cong \angle ABD$

36 Find an equation of the line passing through the point  $(6,5)$  and perpendicular to the line whose equation is  $2y + 3x = 6$ .

37 Write an equation of the circle whose diameter  $\overline{AB}$  has endpoints  $A(-4,2)$  and  $B(4,-4)$ . [The use of the grid below is optional.]

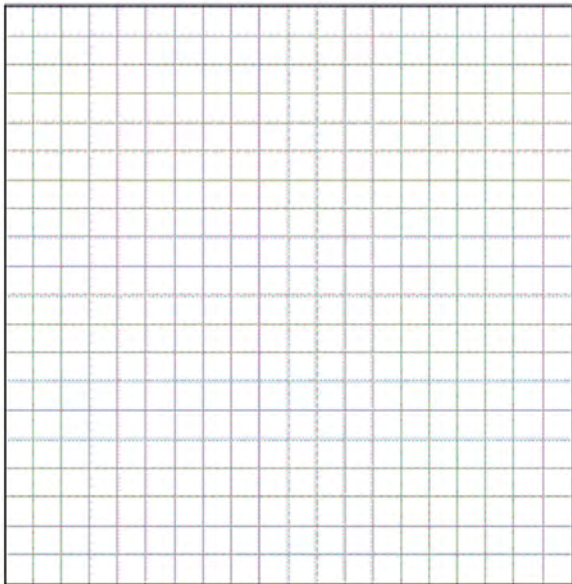

38 In the diagram below, quadrilateral  $STAR$  is a rhombus with diagonals  $\overline{SA}$  and  $\overline{TR}$  intersecting at  $E$ .  $ST = 3x + 30$ ,  $SR = 8x - 5$ ,  $SE = 3z$ ,  $TE = 5z + 5$ ,  $AE = 4z - 8$ ,  $m\angle RTA = 5y - 2$ , and  $m\angle TAS = 9y + 8$ . Find  $SR$ ,  $RT$ , and  $m\angle TAS$ .

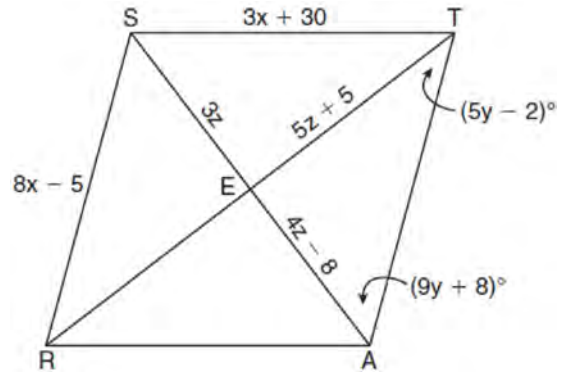

0810ge

- 1 In the diagram below,  $\triangle ABC \cong \triangle XYZ$ .

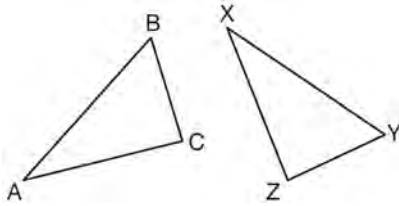

Which two statements identify corresponding congruent parts for these triangles?

- 1)  $\overline{AB} \cong \overline{XY}$  and  $\angle C \cong \angle Y$
  - 2)  $\overline{AB} \cong \overline{YZ}$  and  $\angle C \cong \angle X$
  - 3)  $\overline{BC} \cong \overline{XY}$  and  $\angle A \cong \angle Y$
  - 4)  $\overline{BC} \cong \overline{YZ}$  and  $\angle A \cong \angle X$
- 2 A support beam between the floor and ceiling of a house forms a  $90^\circ$  angle with the floor. The builder wants to make sure that the floor and ceiling are parallel. Which angle should the support beam form with the ceiling?
- 1)  $45^\circ$
  - 2)  $60^\circ$
  - 3)  $90^\circ$
  - 4)  $180^\circ$

- 3 In the diagram below, the vertices of  $\triangle DEF$  are the midpoints of the sides of equilateral triangle  $ABC$ , and the perimeter of  $\triangle ABC$  is 36 cm.

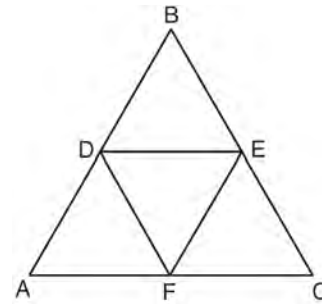

What is the length, in centimeters, of  $\overline{EF}$ ?

- 1) 6
  - 2) 12
  - 3) 18
  - 4) 4
- 4 What is the solution of the following system of equations?
- $$y = (x + 3)^2 - 4$$
- $$y = 2x + 5$$
- 1)  $(0, -4)$
  - 2)  $(-4, 0)$
  - 3)  $(-4, -3)$  and  $(0, 5)$
  - 4)  $(-3, -4)$  and  $(5, 0)$

- 5 One step in a construction uses the endpoints of  $\overline{AB}$  to create arcs with the same radii. The arcs intersect above and below the segment. What is the relationship of  $\overline{AB}$  and the line connecting the points of intersection of these arcs?
- 1) collinear
  - 2) congruent
  - 3) parallel
  - 4) perpendicular

- 6 If  $\triangle ABC \sim \triangle ZXY$ ,  $m\angle A = 50$ , and  $m\angle C = 30$ , what is  $m\angle X$ ?
- 1) 30
  - 2) 50
  - 3) 80
  - 4) 100

- 7 In the diagram below of  $\triangle AGE$  and  $\triangle OLD$ ,  $\angle GAE \cong \angle LOD$ , and  $\overline{AE} \cong \overline{OD}$ .

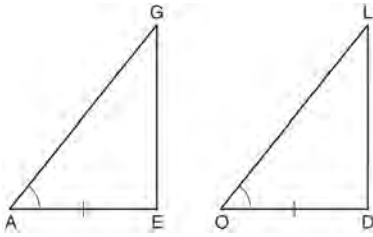

To prove that  $\triangle AGE$  and  $\triangle OLD$  are congruent by SAS, what other information is needed?

- 1)  $\overline{GE} \cong \overline{LD}$
  - 2)  $\overline{AG} \cong \overline{OL}$
  - 3)  $\angle AGE \cong \angle OLD$
  - 4)  $\angle AEG \cong \angle ODL$
- 8 Point  $A$  is not contained in plane  $B$ . How many lines can be drawn through point  $A$  that will be perpendicular to plane  $B$ ?
- 1) one
  - 2) two
  - 3) zero
  - 4) infinite
- 9 The equation of a circle is  $x^2 + (y - 7)^2 = 16$ . What are the center and radius of the circle?
- 1) center =  $(0, 7)$ ; radius = 4
  - 2) center =  $(0, 7)$ ; radius = 16
  - 3) center =  $(0, -7)$ ; radius = 4
  - 4) center =  $(0, -7)$ ; radius = 16

- 10 What is an equation of the line that passes through the point  $(7, 3)$  and is parallel to the line  $4x + 2y = 10$ ?

- 1)  $y = \frac{1}{2}x - \frac{1}{2}$
  - 2)  $y = -\frac{1}{2}x + \frac{13}{2}$
  - 3)  $y = 2x - 11$
  - 4)  $y = -2x + 17$
- 11 In  $\triangle ABC$ ,  $AB = 7$ ,  $BC = 8$ , and  $AC = 9$ . Which list has the angles of  $\triangle ABC$  in order from smallest to largest?
- 1)  $\angle A, \angle B, \angle C$
  - 2)  $\angle B, \angle A, \angle C$
  - 3)  $\angle C, \angle B, \angle A$
  - 4)  $\angle C, \angle A, \angle B$

- 12 Tangents  $\overline{PA}$  and  $\overline{PB}$  are drawn to circle  $O$  from an external point,  $P$ , and radii  $\overline{OA}$  and  $\overline{OB}$  are drawn. If  $m\angle APB = 40$ , what is the measure of  $\angle AOB$ ?
- 1)  $140^\circ$
  - 2)  $100^\circ$
  - 3)  $70^\circ$
  - 4)  $50^\circ$

- 13 What is the length of the line segment with endpoints  $(-6, 4)$  and  $(2, -5)$ ?
- 1)  $\sqrt{13}$
  - 2)  $\sqrt{17}$
  - 3)  $\sqrt{72}$
  - 4)  $\sqrt{145}$

- 14 The lines represented by the equations  $y + \frac{1}{2}x = 4$  and  $3x + 6y = 12$  are
- 1) the same line
  - 2) parallel
  - 3) perpendicular
  - 4) neither parallel nor perpendicular

- 15 A transformation of a polygon that always preserves both length and orientation is
- 1) dilation
  - 2) translation
  - 3) line reflection
  - 4) glide reflection

- 16 In which polygon does the sum of the measures of the interior angles equal the sum of the measures of the exterior angles?
- 1) triangle
  - 2) hexagon
  - 3) octagon
  - 4) quadrilateral

- 17 In the diagram below of circle  $O$ , chords  $\overline{AB}$  and  $\overline{CD}$  intersect at  $E$ .

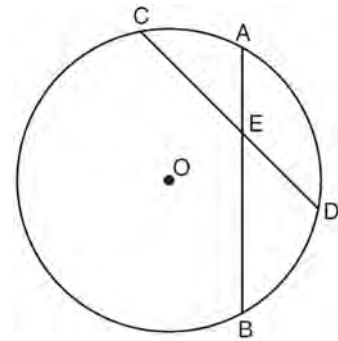

If  $\overline{CE} = 10$ ,  $\overline{ED} = 6$ , and  $\overline{AE} = 4$ , what is the length of  $\overline{EB}$ ?

- 1) 15
  - 2) 12
  - 3) 6.7
  - 4) 2.4
- 18 In the diagram below of  $\triangle ABC$ , medians  $\overline{AD}$ ,  $\overline{BE}$ , and  $\overline{CF}$  intersect at  $G$ .

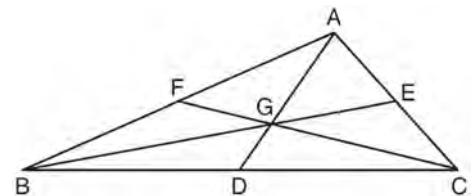

If  $\overline{CF} = 24$ , what is the length of  $\overline{FG}$ ?

- 1) 8
- 2) 10
- 3) 12
- 4) 16

- 19 If a line segment has endpoints  $A(3x + 5, 3y)$  and  $B(x - 1, -y)$ , what are the coordinates of the midpoint of  $\overline{AB}$ ?
- 1)  $(x + 3, 2y)$
  - 2)  $(2x + 2, y)$
  - 3)  $(2x + 3, y)$
  - 4)  $(4x + 4, 2y)$
- 20 If the surface area of a sphere is represented by  $144\pi$ , what is the volume in terms of  $\pi$ ?
- 1)  $36\pi$
  - 2)  $48\pi$
  - 3)  $216\pi$
  - 4)  $288\pi$
- 21 Which transformation of the line  $x = 3$  results in an image that is perpendicular to the given line?
- 1)  $r_{x\text{-axis}}$
  - 2)  $r_{y\text{-axis}}$
  - 3)  $r_{y=x}$
  - 4)  $r_{x=1}$

- 22 In the diagram below of regular pentagon  $ABCDE$ ,  $\overline{EB}$  is drawn.

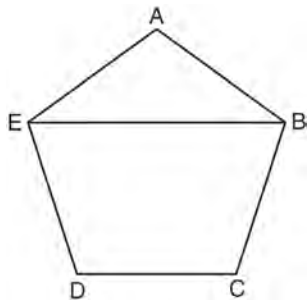

What is the measure of  $\angle AEB$ ?

- 1)  $36^\circ$
- 2)  $54^\circ$
- 3)  $72^\circ$
- 4)  $108^\circ$

- 23  $\triangle ABC$  is similar to  $\triangle DEF$ . The ratio of the length of  $\overline{AB}$  to the length of  $\overline{DE}$  is 3:1. Which ratio is also equal to 3:1?
- 1)  $\frac{m\angle A}{m\angle D}$
  - 2)  $\frac{m\angle B}{m\angle F}$
  - 3)  $\frac{\text{area of } \triangle ABC}{\text{area of } \triangle DEF}$
  - 4)  $\frac{\text{perimeter of } \triangle ABC}{\text{perimeter of } \triangle DEF}$

- 24 What is the slope of a line perpendicular to the line whose equation is  $2y = -6x + 8$ ?
- 1)  $-3$
  - 2)  $\frac{1}{6}$
  - 3)  $\frac{1}{3}$
  - 4)  $-6$

- 25 In the diagram below of circle  $C$ ,  $m\widehat{QT} = 140$ , and  $m\angle P = 40$ .

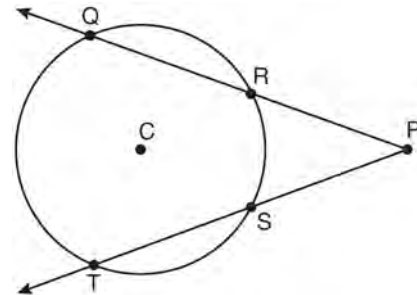

What is  $m\widehat{RS}$ ?

- 1) 50
- 2) 60
- 3) 90
- 4) 110

- 26 Which statement is logically equivalent to "If it is warm, then I go swimming"
- 1) If I go swimming, then it is warm.
  - 2) If it is warm, then I do not go swimming.
  - 3) If I do not go swimming, then it is not warm.
  - 4) If it is not warm, then I do not go swimming.

- 27 In the diagram below of  $\triangle ACT$ ,  $\overleftrightarrow{BE} \parallel \overleftrightarrow{AT}$ .

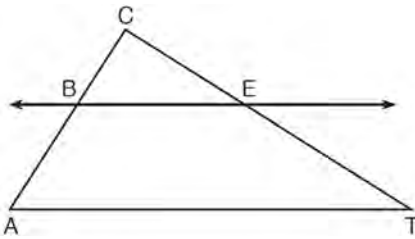

If  $CB = 3$ ,  $CA = 10$ , and  $CE = 6$ , what is the length of  $\overline{ET}$ ?

- 1) 5
- 2) 14
- 3) 20
- 4) 26

- 28 Which geometric principle is used in the construction shown below?

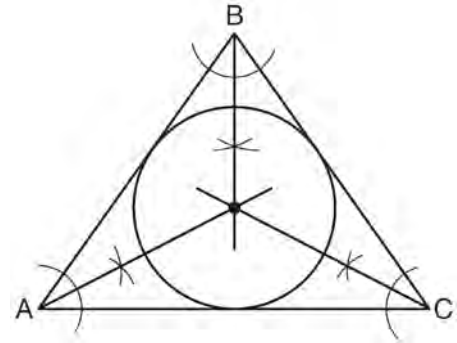

- 1) The intersection of the angle bisectors of a triangle is the center of the inscribed circle.
- 2) The intersection of the angle bisectors of a triangle is the center of the circumscribed circle.
- 3) The intersection of the perpendicular bisectors of the sides of a triangle is the center of the inscribed circle.
- 4) The intersection of the perpendicular bisectors of the sides of a triangle is the center of the circumscribed circle.

- 29 The diagram below shows isosceles trapezoid  $ABCD$  with  $\overline{AB} \parallel \overline{DC}$  and  $\overline{AD} \cong \overline{BC}$ . If  $m\angle BAD = 2x$  and  $m\angle BCD = 3x + 5$ , find  $m\angle BAD$ .

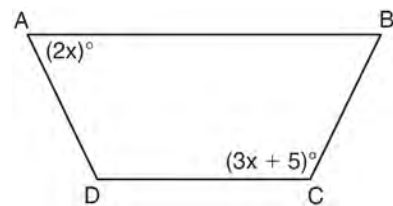

- 30 A right circular cone has a base with a radius of 15 cm, a vertical height of 20 cm, and a slant height of 25 cm. Find, in terms of  $\pi$ , the number of square centimeters in the lateral area of the cone.

- 31 In the diagram below of  $\triangle HQP$ , side  $\overline{HP}$  is extended through  $P$  to  $T$ ,  $m\angle QPT = 6x + 20$ ,  $m\angle HQP = x + 40$ , and  $m\angle PHQ = 4x - 5$ . Find  $m\angle QPT$ .

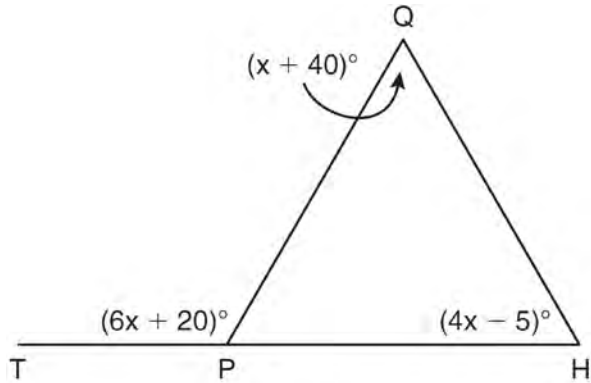

(Not drawn to scale)

- 32 On the line segment below, use a compass and straightedge to construct equilateral triangle  $ABC$ . [Leave all construction marks.]



- 33 In the diagram below, car A is parked 7 miles from car B. Sketch the points that are 4 miles from car A and sketch the points that are 4 miles from car B. Label with an **X** all points that satisfy both conditions.

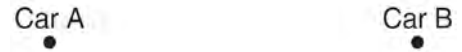

- 34 Write an equation for circle  $O$  shown on the graph below.

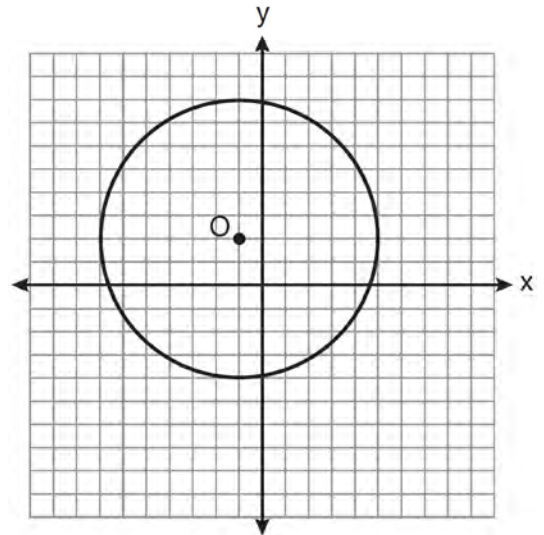

- 35 In the diagram below of quadrilateral  $ABCD$  with diagonal  $\overline{BD}$ ,  $m\angle A = 93$ ,  $m\angle ADB = 43$ ,  $m\angle C = 3x + 5$ ,  $m\angle BDC = x + 19$ , and  $m\angle DBC = 2x + 6$ . Determine if  $\overline{AB}$  is parallel to  $\overline{DC}$ . Explain your reasoning.

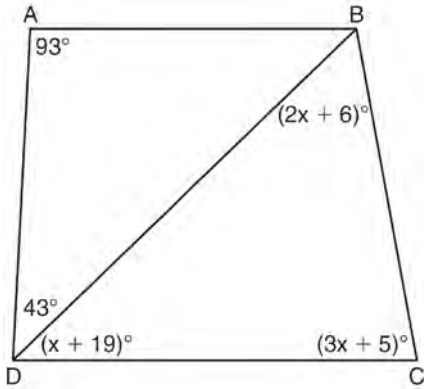

- 36 The coordinates of the vertices of  $\triangle ABC$  are  $A(1,3)$ ,  $B(-2,2)$  and  $C(0,-2)$ . On the grid below, graph and label  $\triangle A''B''C''$ , the result of the composite transformation  $D_2 \circ T_{3,-2}$ . State the coordinates of  $A''$ ,  $B''$ , and  $C''$ .

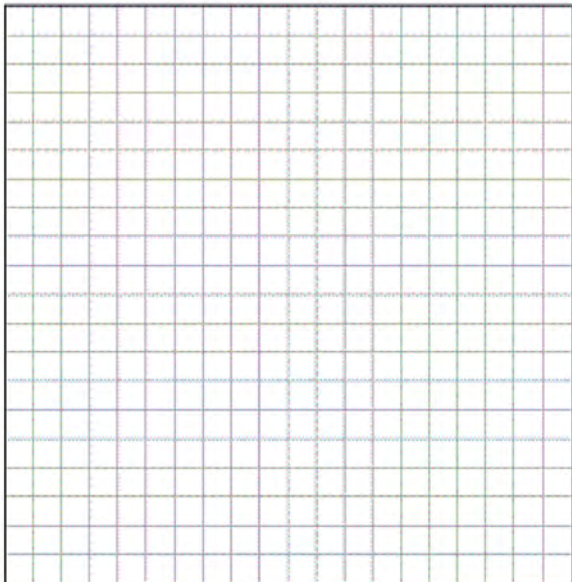

- 37 In the diagram below,  $\triangle RST$  is a 3-4-5 right triangle. The altitude,  $h$ , to the hypotenuse has been drawn. Determine the length of  $h$ .

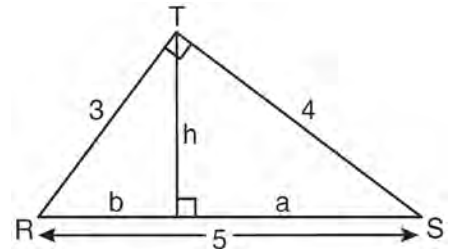

- 38 Given: Quadrilateral  $ABCD$  has vertices  $A(-5,6)$ ,  $B(6,6)$ ,  $C(8,-3)$ , and  $D(-3,-3)$ . Prove: Quadrilateral  $ABCD$  is a parallelogram but is neither a rhombus nor a rectangle. [The use of the grid below is optional.]

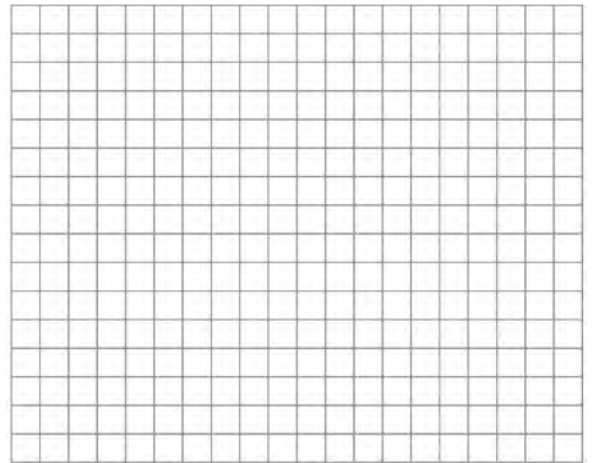



0111ge

- 1 In the diagram below,  $\overline{AB}$ ,  $\overline{BC}$ , and  $\overline{AC}$  are tangents to circle  $O$  at points  $F$ ,  $E$ , and  $D$ , respectively,  $AF = 6$ ,  $CD = 5$ , and  $BE = 4$ .

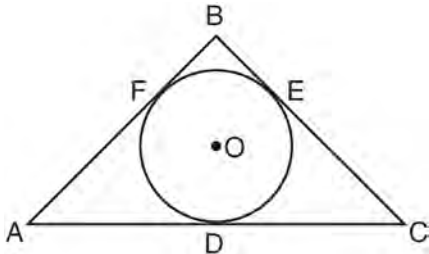

What is the perimeter of  $\triangle ABC$ ?

- 1) 15
  - 2) 25
  - 3) 30
  - 4) 60
- 2 Quadrilateral  $MNOP$  is a trapezoid with  $\overline{MN} \parallel \overline{OP}$ . If  $M'N'O'P'$  is the image of  $MNOP$  after a reflection over the  $x$ -axis, which two sides of quadrilateral  $M'N'O'P'$  are parallel?
- 1)  $\overline{M'N'}$  and  $\overline{O'P'}$
  - 2)  $\overline{M'N'}$  and  $\overline{N'O'}$
  - 3)  $\overline{P'M'}$  and  $\overline{O'P'}$
  - 4)  $\overline{P'M'}$  and  $\overline{N'O'}$

- 3 In the diagram below of  $\triangle ABC$ ,  $D$  is the midpoint of  $\overline{AB}$ , and  $E$  is the midpoint of  $\overline{BC}$ .

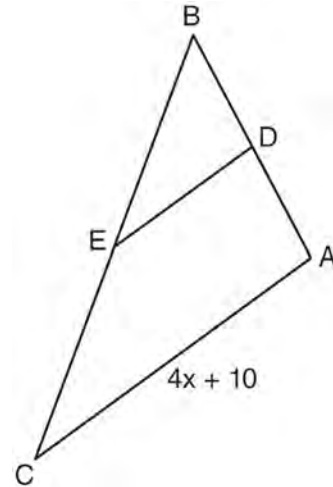

If  $AC = 4x + 10$ , which expression represents  $DE$ ?

- 1)  $x + 2.5$
  - 2)  $2x + 5$
  - 3)  $2x + 10$
  - 4)  $8x + 20$
- 4 Which statement is true about every parallelogram?
- 1) All four sides are congruent.
  - 2) The interior angles are all congruent.
  - 3) Two pairs of opposite sides are congruent.
  - 4) The diagonals are perpendicular to each other.

- 5 The diagram below shows a rectangular prism.

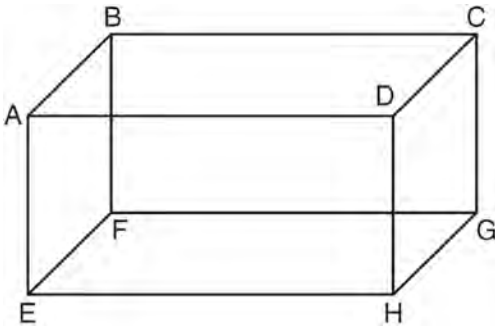

Which pair of edges are segments of lines that are coplanar?

- 1)  $\overline{AB}$  and  $\overline{DH}$
  - 2)  $\overline{AE}$  and  $\overline{DC}$
  - 3)  $\overline{BC}$  and  $\overline{EH}$
  - 4)  $\overline{CG}$  and  $\overline{EF}$
- 6 A line segment has endpoints  $A(7, -1)$  and  $B(-3, 3)$ . What are the coordinates of the midpoint of  $\overline{AB}$ ?
- 1) (1, 2)
  - 2) (2, 1)
  - 3) (-5, 2)
  - 4) (5, -2)
- 7 What is the image of the point  $(-5, 2)$  under the translation  $T_{3, -4}$ ?
- 1) (-9, 5)
  - 2) (-8, 6)
  - 3) (-2, -2)
  - 4) (-15, -8)
- 8 When writing a geometric proof, which angle relationship could be used alone to justify that two angles are congruent?
- 1) supplementary angles
  - 2) linear pair of angles
  - 3) adjacent angles
  - 4) vertical angles

- 9 Plane  $\mathcal{R}$  is perpendicular to line  $k$  and plane  $\mathcal{D}$  is perpendicular to line  $k$ . Which statement is correct?
- 1) Plane  $\mathcal{R}$  is perpendicular to plane  $\mathcal{D}$ .
  - 2) Plane  $\mathcal{R}$  is parallel to plane  $\mathcal{D}$ .
  - 3) Plane  $\mathcal{R}$  intersects plane  $\mathcal{D}$ .
  - 4) Plane  $\mathcal{R}$  bisects plane  $\mathcal{D}$ .
- 10 The vertices of the triangle in the diagram below are  $A(7, 9)$ ,  $B(3, 3)$ , and  $C(11, 3)$ .

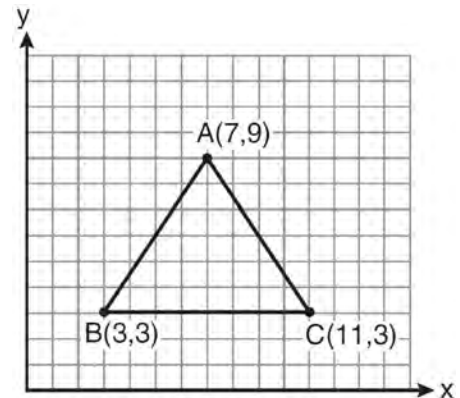

What are the coordinates of the centroid of  $\triangle ABC$ ?

- 1) (5, 6)
  - 2) (7, 3)
  - 3) (7, 5)
  - 4) (9, 6)
- 11 Which set of numbers does *not* represent the sides of a right triangle?
- 1) {6, 8, 10}
  - 2) {8, 15, 17}
  - 3) {8, 24, 25}
  - 4) {15, 36, 39}

- 12 In the diagram below of rhombus  $ABCD$ ,  $m\angle C = 100$ .

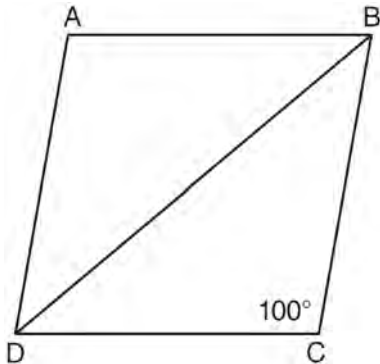

What is  $m\angle DBC$ ?

- 1) 40
  - 2) 45
  - 3) 50
  - 4) 80
- 13 In the diagram below of circle  $O$ , radius  $\overline{OC}$  is 5 cm. Chord  $\overline{AB}$  is 8 cm and is perpendicular to  $\overline{OC}$  at point  $P$ .

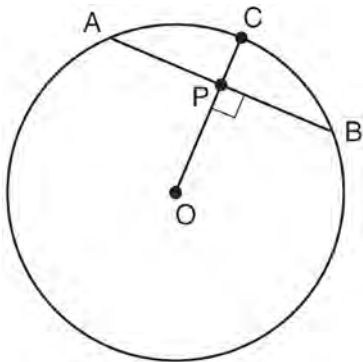

What is the length of  $\overline{OP}$ , in centimeters?

- 14 What is an equation of the line that passes through the point  $(-2, 3)$  and is parallel to the line whose equation is  $y = \frac{3}{2}x - 4$ ?

- 1)  $y = \frac{-2}{3}x$
  - 2)  $y = \frac{-2}{3}x + \frac{5}{3}$
  - 3)  $y = \frac{3}{2}x$
  - 4)  $y = \frac{3}{2}x + 6$
- 15 In scalene triangle  $ABC$ ,  $m\angle B = 45$  and  $m\angle C = 55$ . What is the order of the sides in length, from longest to shortest?
- 1)  $\overline{AB}, \overline{BC}, \overline{AC}$
  - 2)  $\overline{BC}, \overline{AC}, \overline{AB}$
  - 3)  $\overline{AC}, \overline{BC}, \overline{AB}$
  - 4)  $\overline{BC}, \overline{AB}, \overline{AC}$

- 16 What is an equation of a circle with center  $(7, -3)$  and radius 4?

- 1)  $(x - 7)^2 + (y + 3)^2 = 4$
  - 2)  $(x + 7)^2 + (y - 3)^2 = 4$
  - 3)  $(x - 7)^2 + (y + 3)^2 = 16$
  - 4)  $(x + 7)^2 + (y - 3)^2 = 16$
- 17 What is the volume, in cubic centimeters, of a cylinder that has a height of 15 cm and a diameter of 12 cm?
- 1)  $180\pi$
  - 2)  $540\pi$
  - 3)  $675\pi$
  - 4)  $2,160\pi$

- 18 Which compound statement is true?
- 1) A triangle has three sides and a quadrilateral has five sides.
  - 2) A triangle has three sides if and only if a quadrilateral has five sides.
  - 3) If a triangle has three sides, then a quadrilateral has five sides.
  - 4) A triangle has three sides or a quadrilateral has five sides.

- 19 The two lines represented by the equations below are graphed on a coordinate plane.

$$x + 6y = 12$$

$$3(x - 2) = -y - 4$$

Which statement best describes the two lines?

- 1) The lines are parallel.
- 2) The lines are the same line.
- 3) The lines are perpendicular.
- 4) The lines intersect at an angle other than  $90^\circ$ .

- 20 Which diagram shows the construction of the perpendicular bisector of  $\overline{AB}$ ?

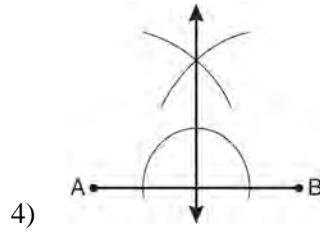
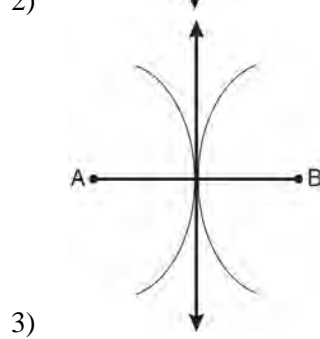
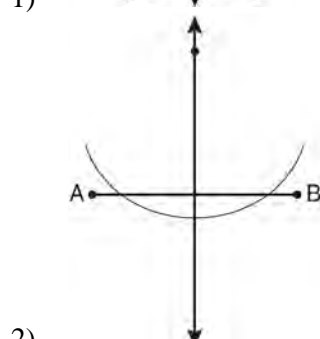
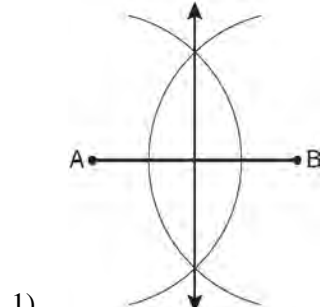

- 21 In circle  $O$ , a diameter has endpoints  $(-5, 4)$  and  $(3, -6)$ . What is the length of the diameter?

- 1)  $\sqrt{2}$
- 2)  $2\sqrt{2}$
- 3)  $\sqrt{10}$
- 4)  $2\sqrt{41}$

- 22 In the diagram of quadrilateral  $ABCD$ ,  $\overline{AB} \parallel \overline{CD}$ ,  $\angle ABC \cong \angle CDA$ , and diagonal  $\overline{AC}$  is drawn.

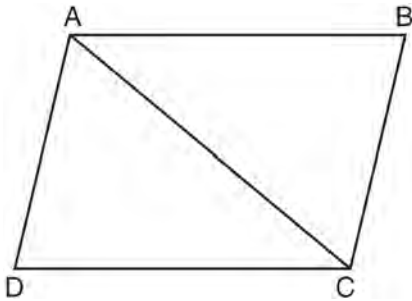

Which method can be used to prove  $\triangle ABC$  is congruent to  $\triangle CDA$ ?

- 1) AAS
  - 2) SSA
  - 3) SAS
  - 4) SSS
- 23 In the diagram below of right triangle  $ABC$ ,  $\overline{CD}$  is the altitude to hypotenuse  $\overline{AB}$ ,  $CB = 6$ , and  $AD = 5$ .

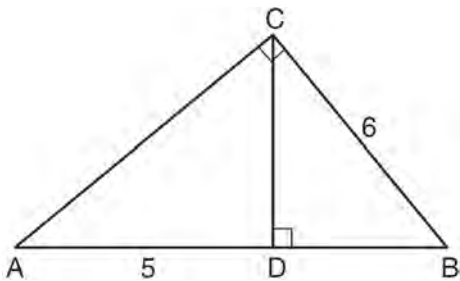

What is the length of  $\overline{BD}$ ?

- 1) 5
- 2) 9
- 3) 3
- 4) 4

- 24 In the diagram below, quadrilateral  $JUMP$  is inscribed in a circle..

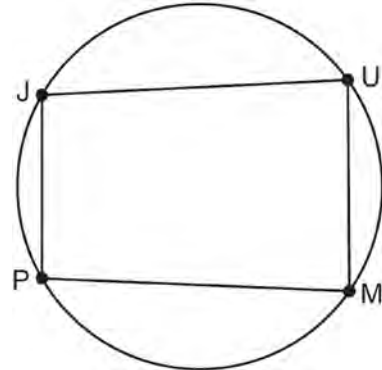

Opposite angles  $J$  and  $M$  must be

- 1) right
- 2) complementary
- 3) congruent
- 4) supplementary

- 25 Which graph represents a circle with the equation  $(x - 3)^2 + (y + 1)^2 = 4$ ?

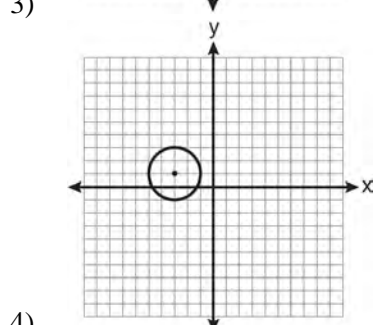
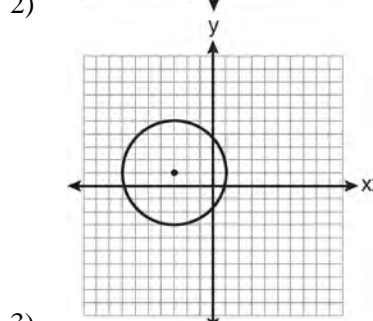
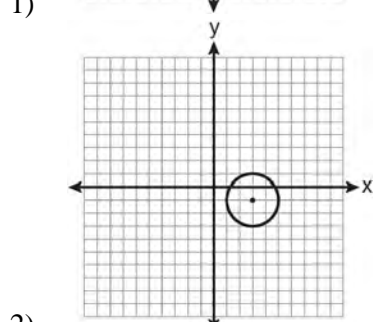
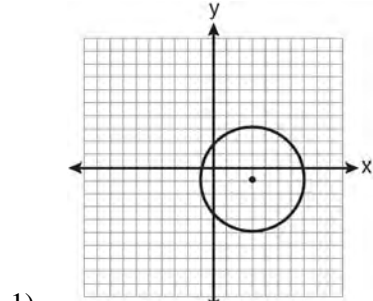

- 26 The point  $(3, -2)$  is rotated  $90^\circ$  about the origin and then dilated by a scale factor of 4. What are the coordinates of the resulting image?
- 1)  $(-12, 8)$
  - 2)  $(12, -8)$
  - 3)  $(8, 12)$
  - 4)  $(-8, -12)$

- 27 In the diagram below of  $\triangle ABC$ , side  $\overline{BC}$  is extended to point  $D$ ,  $m\angle A = x$ ,  $m\angle B = 2x + 15$ , and  $m\angle ACD = 5x + 5$ .

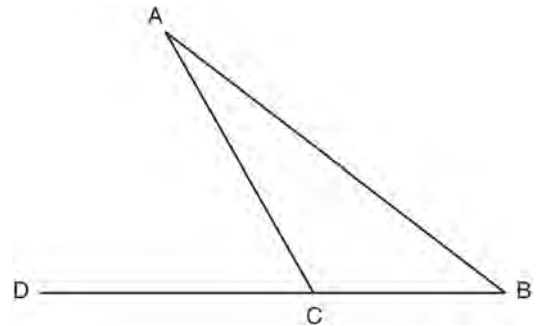

What is  $m\angle B$ ?

- 1) 5
  - 2) 20
  - 3) 25
  - 4) 55
- 28 Point  $P$  lies on line  $m$ . Point  $P$  is also included in distinct planes  $Q$ ,  $R$ ,  $S$ , and  $T$ . At most, how many of these planes could be perpendicular to line  $m$ ?
- 1) 1
  - 2) 2
  - 3) 3
  - 4) 4

- 29 In the diagram below of  $\triangle ACD$ ,  $B$  is a point on  $\overline{AC}$  such that  $\triangle ADB$  is an equilateral triangle, and  $\triangle DBC$  is an isosceles triangle with  $\overline{DB} \cong \overline{BC}$ . Find  $m\angle C$ .

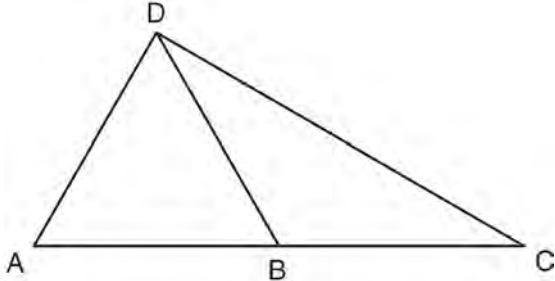

- 30 Triangle  $ABC$  has vertices  $A(-2,2)$ ,  $B(-1,-3)$ , and  $C(4,0)$ . Find the coordinates of the vertices of  $\triangle A'B'C'$ , the image of  $\triangle ABC$  after the transformation  $r_{x\text{-axis}}$ . [The use of the grid is optional.]

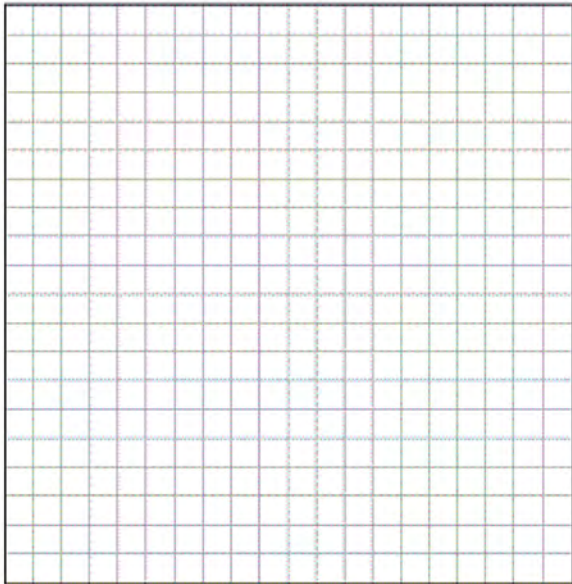

- 31 Find, in degrees, the measures of both an interior angle and an exterior angle of a regular pentagon.

- 32 In the diagram below of circle  $O$ , chord  $\overline{AB}$  bisects chord  $\overline{CD}$  at  $E$ . If  $AE = 8$  and  $BE = 9$ , find the length of  $\overline{CE}$  in simplest radical form.

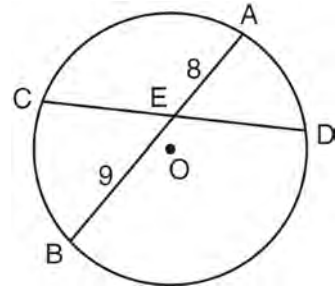

- 33 On the diagram below, use a compass and straightedge to construct the bisector of  $\angle ABC$ . [Leave all construction marks.]

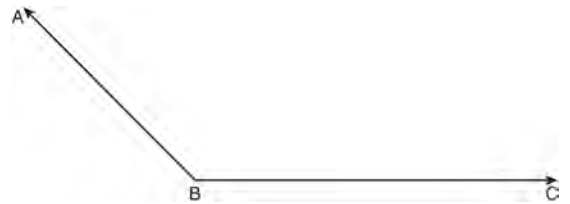

- 34 Find the slope of a line perpendicular to the line whose equation is  $2y - 6x = 4$ .

- 35 On the set of axes below, graph the locus of points that are four units from the point  $(2, 1)$ . On the same set of axes, graph the locus of points that are two units from the line  $x = 4$ . State the coordinates of all points that satisfy both conditions.

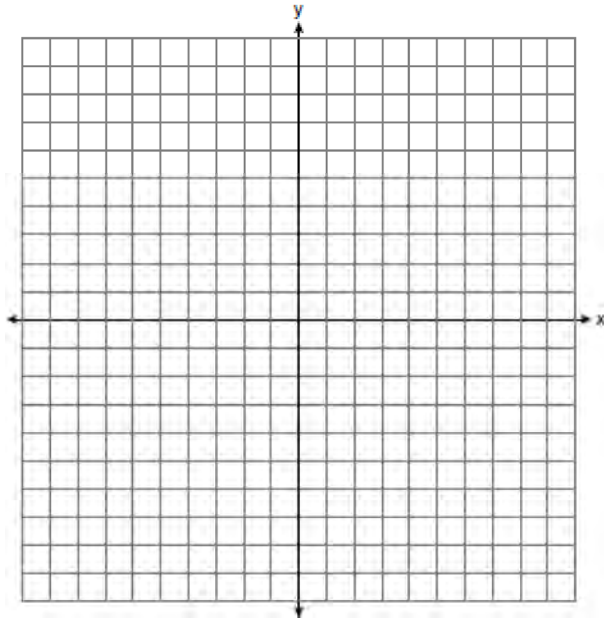

- 36 In the diagram below,  $\overline{BFCE}$ ,  $\overline{AB} \perp \overline{BE}$ ,  $\overline{DE} \perp \overline{BE}$ , and  $\angle BFD \cong \angle ECA$ . Prove that  $\triangle ABC \sim \triangle DEF$ .

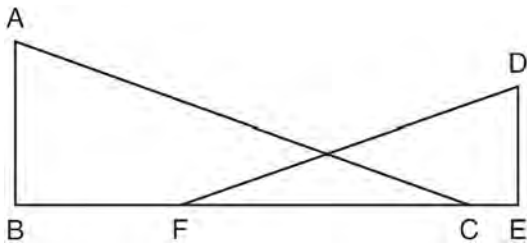

- 37 In the diagram below of  $\triangle ADE$ ,  $B$  is a point on  $\overline{AE}$  and  $C$  is a point on  $\overline{AD}$  such that  $\overline{BC} \parallel \overline{ED}$ ,  $AC = x - 3$ ,  $BE = 20$ ,  $AB = 16$ , and  $AD = 2x + 2$ . Find the length of  $\overline{AC}$ .

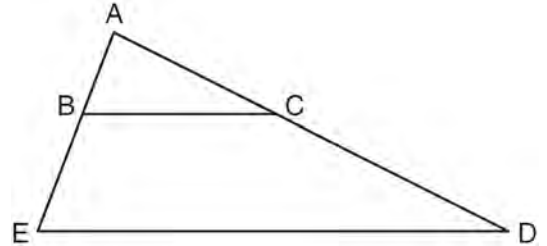

- 38 Quadrilateral  $MATH$  has coordinates  $M(1, 1)$ ,  $A(-2, 5)$ ,  $T(3, 5)$ , and  $H(6, 1)$ . Prove that quadrilateral  $MATH$  is a rhombus and prove that it is *not* a square. [The use of the grid is optional.]

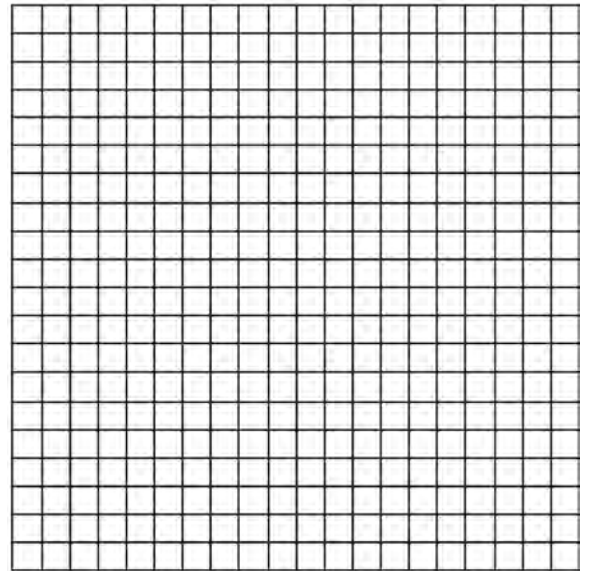



0611ge

- 1 Line segment  $AB$  is shown in the diagram below.

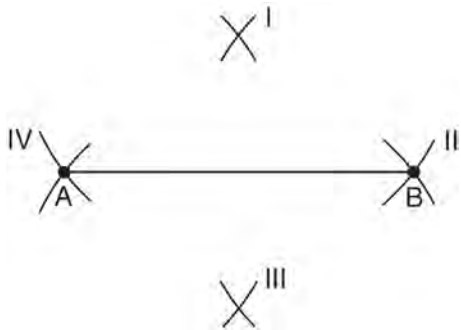

Which two sets of construction marks, labeled I, II, III, and IV, are part of the construction of the perpendicular bisector of line segment  $AB$ ?

- 1) I and II
  - 2) I and III
  - 3) II and III
  - 4) II and IV
- 2 If  $\triangle JKL \cong \triangle MNO$ , which statement is always true?
- 1)  $\angle K LJ \cong \angle NMO$
  - 2)  $\angle KJL \cong \angle MON$
  - 3)  $\overline{JL} \cong \overline{MO}$
  - 4)  $\overline{JK} \cong \overline{ON}$

- 3 In the diagram below,  $\triangle A'B'C'$  is a transformation of  $\triangle ABC$ , and  $\triangle A''B''C''$  is a transformation of  $\triangle A'B'C'$ .

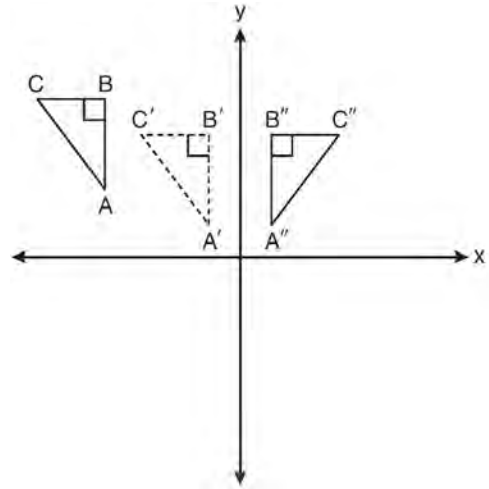

The composite transformation of  $\triangle ABC$  to  $\triangle A''B''C''$  is an example of a

- 1) reflection followed by a rotation
- 2) reflection followed by a translation
- 3) translation followed by a rotation
- 4) translation followed by a reflection

- 4 In the diagram below of  $\triangle ACE$ , medians  $\overline{AD}$ ,  $\overline{EB}$ , and  $\overline{CF}$  intersect at  $G$ . The length of  $\overline{FG}$  is 12 cm.

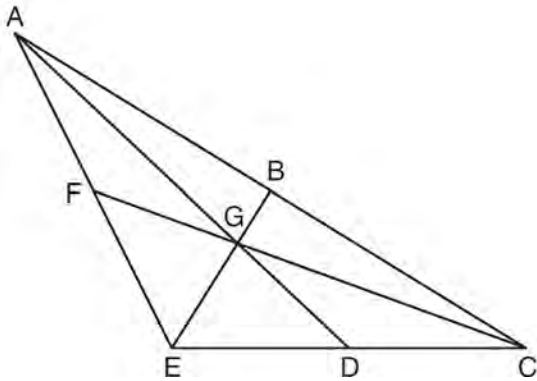

What is the length, in centimeters, of  $\overline{GC}$ ?

- 1) 24
  - 2) 12
  - 3) 6
  - 4) 4
- 5 In the diagram below of circle  $O$ , chord  $\overline{AB}$  is parallel to chord  $\overline{CD}$ .

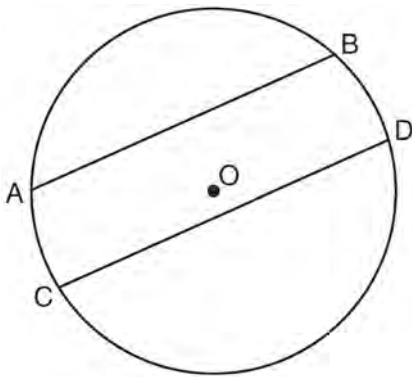

Which statement must be true?

- 1)  $\widehat{AC} \cong \widehat{BD}$
- 2)  $\widehat{AB} \cong \widehat{CD}$
- 3)  $\overline{AB} \cong \overline{CD}$
- 4)  $\widehat{ABD} \cong \widehat{CDB}$

- 6 In the diagram below, line  $p$  intersects line  $m$  and line  $n$ .

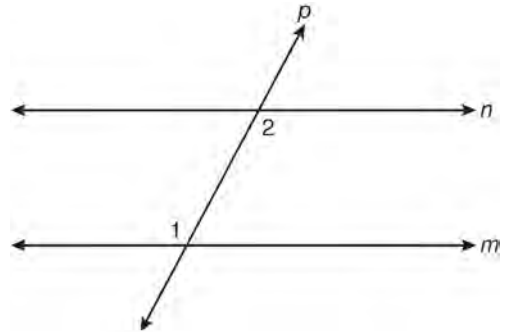

If  $m\angle 1 = 7x$  and  $m\angle 2 = 5x + 30$ , lines  $m$  and  $n$  are parallel when  $x$  equals

- 1) 12.5
  - 2) 15
  - 3) 87.5
  - 4) 105
- 7 In the diagram of  $\triangle KLM$  below,  $m\angle L = 70$ ,  $m\angle M = 50$ , and  $\overline{MK}$  is extended through  $N$ .

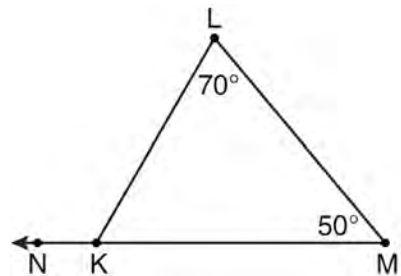

What is the measure of  $\angle LKN$ ?

- 1)  $60^\circ$
- 2)  $120^\circ$
- 3)  $180^\circ$
- 4)  $300^\circ$

8 If two distinct planes,  $\mathcal{A}$  and  $\mathcal{B}$ , are perpendicular to line  $c$ , then which statement is true?

- 1) Planes  $\mathcal{A}$  and  $\mathcal{B}$  are parallel to each other.
- 2) Planes  $\mathcal{A}$  and  $\mathcal{B}$  are perpendicular to each other.
- 3) The intersection of planes  $\mathcal{A}$  and  $\mathcal{B}$  is a line parallel to line  $c$ .
- 4) The intersection of planes  $\mathcal{A}$  and  $\mathcal{B}$  is a line perpendicular to line  $c$ .

9 What is the length of the line segment whose endpoints are  $A(-1,9)$  and  $B(7,4)$ ?

- 1)  $\sqrt{61}$
- 2)  $\sqrt{89}$
- 3)  $\sqrt{205}$
- 4)  $\sqrt{233}$

10 What is an equation of circle  $O$  shown in the graph below?

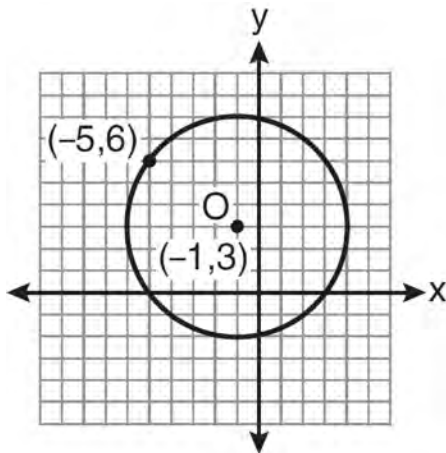

- 1)  $(x + 1)^2 + (y - 3)^2 = 25$
- 2)  $(x - 1)^2 + (y + 3)^2 = 25$
- 3)  $(x - 5)^2 + (y + 6)^2 = 25$
- 4)  $(x + 5)^2 + (y - 6)^2 = 25$

11 In the diagram below, parallelogram  $ABCD$  has diagonals  $\overline{AC}$  and  $\overline{BD}$  that intersect at point  $E$ .

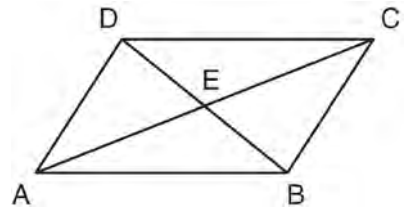

Which expression is *not* always true?

- 1)  $\angle DAE \cong \angle BCE$
- 2)  $\angle DEC \cong \angle BEA$
- 3)  $\overline{AC} \cong \overline{DB}$
- 4)  $\overline{DE} \cong \overline{EB}$

12 The volume, in cubic centimeters, of a sphere whose diameter is 6 centimeters is

- 1)  $12\pi$
- 2)  $36\pi$
- 3)  $48\pi$
- 4)  $288\pi$

13 The equation of line  $k$  is  $y = \frac{1}{3}x - 2$ . The equation of line  $m$  is  $-2x + 6y = 18$ . Lines  $k$  and  $m$  are

- 1) parallel
- 2) perpendicular
- 3) the same line
- 4) neither parallel nor perpendicular

14 What are the center and the radius of the circle whose equation is  $(x - 5)^2 + (y + 3)^2 = 16$ ?

- 1)  $(-5, 3)$  and 16
- 2)  $(5, -3)$  and 16
- 3)  $(-5, 3)$  and 4
- 4)  $(5, -3)$  and 4

15 Triangle  $ABC$  has vertices  $A(0,0)$ ,  $B(3,2)$ , and  $C(0,4)$ . The triangle may be classified as

- 1) equilateral
- 2) isosceles
- 3) right
- 4) scalene

- 16 In rhombus  $ABCD$ , the diagonals  $\overline{AC}$  and  $\overline{BD}$  intersect at  $E$ . If  $AE = 5$  and  $BE = 12$ , what is the length of  $\overline{AB}$ ?
- 1) 7
  - 2) 10
  - 3) 13
  - 4) 17

- 17 In the diagram below of circle  $O$ ,  $\overline{PA}$  is tangent to circle  $O$  at  $A$ , and  $\overline{PBC}$  is a secant with points  $B$  and  $C$  on the circle.

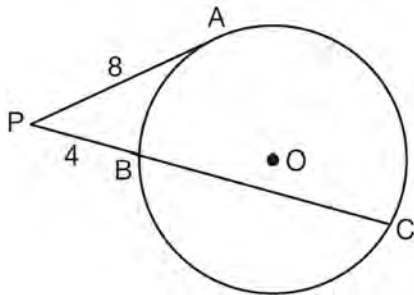

If  $PA = 8$  and  $PB = 4$ , what is the length of  $\overline{BC}$ ?

- 1) 20
  - 2) 16
  - 3) 15
  - 4) 12
- 18 Lines  $m$  and  $n$  intersect at point  $A$ . Line  $k$  is perpendicular to both lines  $m$  and  $n$  at point  $A$ . Which statement *must* be true?
- 1) Lines  $m$ ,  $n$ , and  $k$  are in the same plane.
  - 2) Lines  $m$  and  $n$  are in two different planes.
  - 3) Lines  $m$  and  $n$  are perpendicular to each other.
  - 4) Line  $k$  is perpendicular to the plane containing lines  $m$  and  $n$ .
- 19 In  $\triangle DEF$ ,  $m\angle D = 3x + 5$ ,  $m\angle E = 4x - 15$ , and  $m\angle F = 2x + 10$ . Which statement is true?
- 1)  $DF = FE$
  - 2)  $DE = FE$
  - 3)  $m\angle E = m\angle F$
  - 4)  $m\angle D = m\angle F$

- 20 As shown in the diagram below,  $\triangle ABC \sim \triangle DEF$ ,  $AB = 7x$ ,  $BC = 4$ ,  $DE = 7$ , and  $EF = x$ .

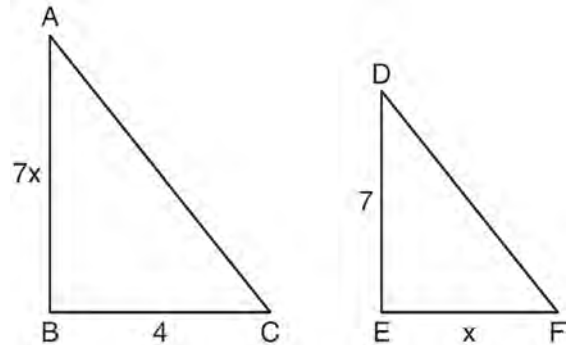

What is the length of  $\overline{AB}$ ?

- 1) 28
  - 2) 2
  - 3) 14
  - 4) 4
- 21 A man wants to place a new bird bath in his yard so that it is 30 feet from a fence,  $f$ , and also 10 feet from a light pole,  $P$ . As shown in the diagram below, the light pole is 35 feet away from the fence.

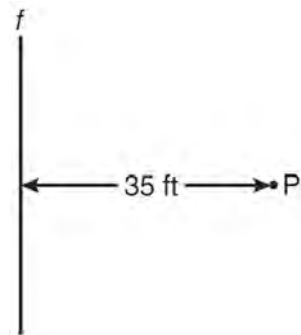

How many locations are possible for the bird bath?

- 1) 1
- 2) 2
- 3) 3
- 4) 0

- 22 As shown on the graph below,  $\triangle R'S'T'$  is the image of  $\triangle RST$  under a single transformation.

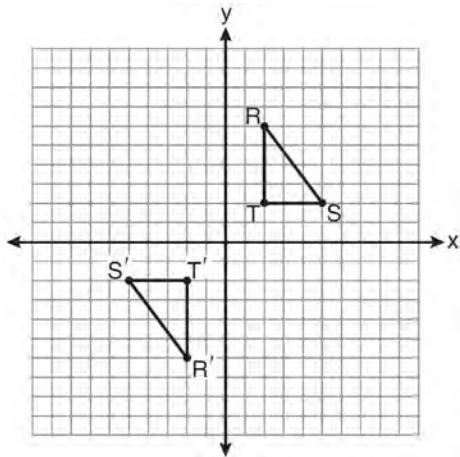

Which transformation does this graph represent?

- 1) glide reflection
  - 2) line reflection
  - 3) rotation
  - 4) translation
- 23 Which lines is parallel to the line whose equation is  $4x + 3y = 7$  and also passes through the point  $(-5, 2)$ ?
- 1)  $4x + 3y = -26$
  - 2)  $4x + 3y = -14$
  - 3)  $3x + 4y = -7$
  - 4)  $3x + 4y = 14$
- 24 If the vertex angles of two isosceles triangles are congruent, then the triangles must be
- 1) acute
  - 2) congruent
  - 3) right
  - 4) similar
- 25 Which quadrilateral has diagonals that always bisect its angles and also bisect each other?
- 1) rhombus
  - 2) rectangle
  - 3) parallelogram
  - 4) isosceles trapezoid

- 26 When  $\triangle ABC$  is dilated by a scale factor of 2, its image is  $\triangle A'B'C'$ . Which statement is true?
- 1)  $\overline{AC} \cong \overline{A'C'}$
  - 2)  $\angle A \cong \angle A'$
  - 3) perimeter of  $\triangle ABC =$  perimeter of  $\triangle A'B'C'$
  - 4)  $2(\text{area of } \triangle ABC) = \text{area of } \triangle A'B'C'$

- 27 What is the slope of a line that is perpendicular to the line whose equation is  $3x + 5y = 4$ ?
- 1)  $-\frac{3}{5}$
  - 2)  $\frac{3}{5}$
  - 3)  $-\frac{5}{3}$
  - 4)  $\frac{5}{3}$

- 28 In the diagram below of right triangle  $ABC$ , altitude  $\overline{BD}$  is drawn to hypotenuse  $\overline{AC}$ ,  $AC = 16$ , and  $CD = 7$ .

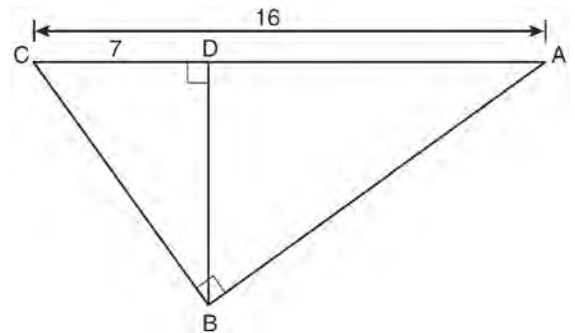

What is the length of  $\overline{BD}$ ?

- 1)  $3\sqrt{7}$
  - 2)  $4\sqrt{7}$
  - 3)  $7\sqrt{3}$
  - 4) 12
- 29 Given the true statement, "The medians of a triangle are concurrent," write the negation of the statement and give the truth value for the negation.

- 30 Using a compass and straightedge, on the diagram below of  $\overleftrightarrow{RS}$ , construct an equilateral triangle with  $\overline{RS}$  as one side. [Leave all construction marks.]



- 31 The Parkside Packing Company needs a rectangular shipping box. The box must have a length of 11 inches and a width of 8 inches. Find, to the nearest tenth of an inch, the minimum height of the box such that the volume is at least 800 cubic inches.

- 32 A pentagon is drawn on the set of axes below. If the pentagon is reflected over the  $y$ -axis, determine if this transformation is an isometry. Justify your answer. [The use of the set of axes is optional.]

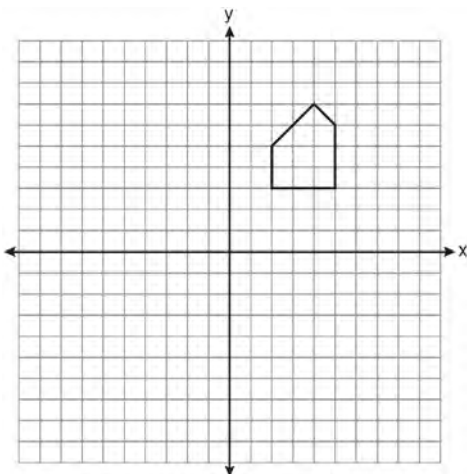

- 33 In the diagram below of  $\triangle ABC$ ,  $D$  is a point on  $\overline{AB}$ ,  $E$  is a point on  $\overline{BC}$ ,  $\overline{AC} \parallel \overline{DE}$ ,  $CE = 25$  inches,  $AD = 18$  inches, and  $DB = 12$  inches. Find, to the nearest tenth of an inch, the length of  $\overline{EB}$ .

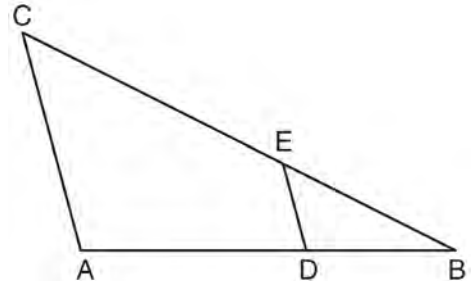

- 34 In circle  $O$ , diameter  $\overline{RS}$  has endpoints  $R(3a, 2b - 1)$  and  $S(a - 6, 4b + 5)$ . Find the coordinates of point  $O$ , in terms of  $a$  and  $b$ . Express your answer in simplest form.
- 35 On the set of coordinate axes below, graph the locus of points that are equidistant from the lines  $y = 6$  and  $y = 2$  and also graph the locus of points that are 3 units from the  $y$ -axis. State the coordinates of all points that satisfy both conditions.

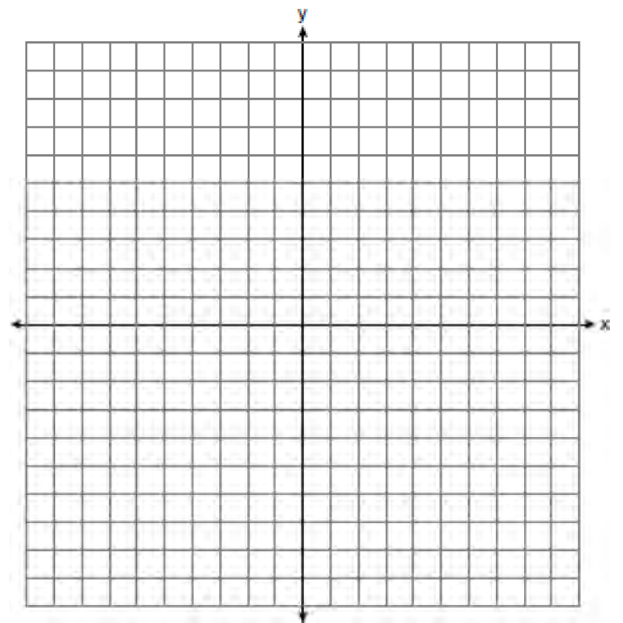

- 36 In the diagram below, tangent  $\overline{ML}$  and secant  $\overline{MNK}$  are drawn to circle  $O$ . The ratio  $m\widehat{LN} : m\widehat{NK} : m\widehat{KL}$  is 3:4:5. Find  $m\angle LMK$ .

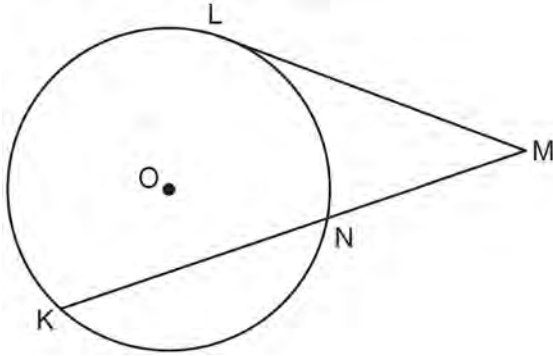

- 38 In the diagram below,  $\overline{PA}$  and  $\overline{PB}$  are tangent to circle  $O$ ,  $\overline{OA}$  and  $\overline{OB}$  are radii, and  $\overline{OP}$  intersects the circle at  $C$ . Prove:  $\angle AOP \cong \angle BOP$

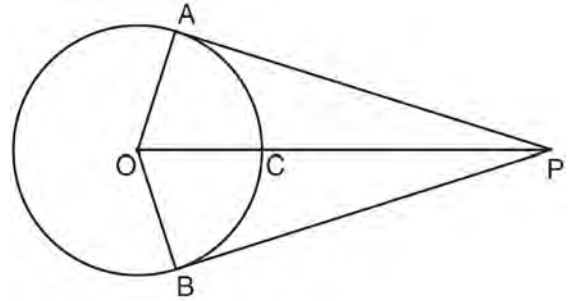

- 37 Solve the following system of equations graphically.

$$2x^2 - 4x = y + 1$$

$$x + y = 1$$

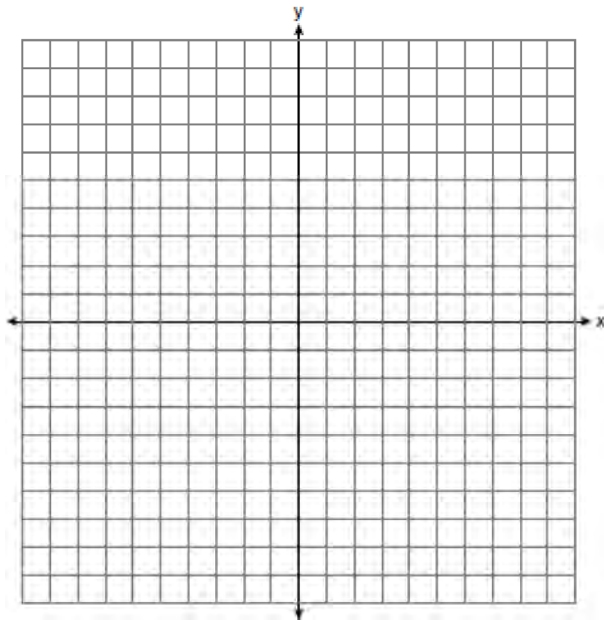

0811ge

1 The statement " $x$  is a multiple of 3, and  $x$  is an even integer" is true when  $x$  is equal to

- 1) 9
- 2) 8
- 3) 3
- 4) 6

2 In the diagram below,  $\triangle ABC \cong \triangle XYZ$ .

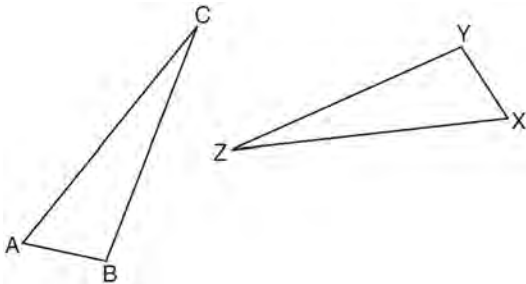

Which statement must be true?

- 1)  $\angle C \cong \angle Y$
- 2)  $\angle A \cong \angle X$
- 3)  $\overline{AC} \cong \overline{YZ}$
- 4)  $\overline{CB} \cong \overline{XZ}$

3 In the diagram below of  $\triangle ABC$ ,  $\overleftrightarrow{TV} \parallel \overline{BC}$ ,  $AT = 5$ ,  $TB = 7$ , and  $AV = 10$ .

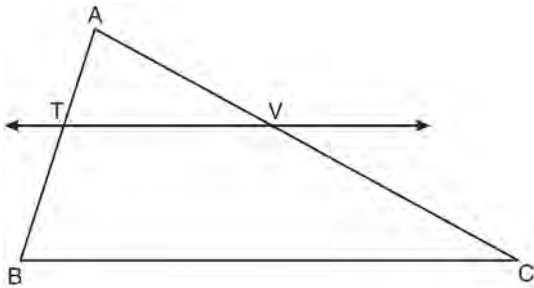

What is the length of  $\overline{VC}$ ?

- 1)  $3\frac{1}{2}$
- 2)  $7\frac{1}{7}$
- 3) 14
- 4) 24

4 Pentagon  $PQRST$  has  $\overline{PQ}$  parallel to  $\overline{TS}$ . After a translation of  $T_{2,-5}$ , which line segment is parallel to  $\overline{P'Q'}$ ?

- 1)  $\overline{R'Q'}$
- 2)  $\overline{R'S'}$
- 3)  $\overline{T'S'}$
- 4)  $\overline{T'P'}$

5 In the diagram below of  $\triangle PAO$ ,  $\overline{AP}$  is tangent to circle  $O$  at point  $A$ ,  $OB = 7$ , and  $BP = 18$ .

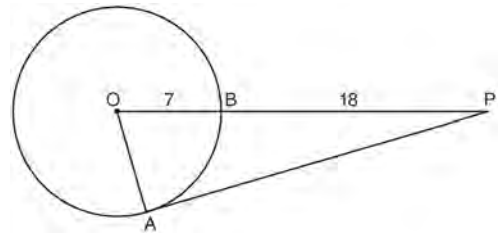

What is the length of  $\overline{AP}$ ?

- 1) 10
- 2) 12
- 3) 17
- 4) 24



- 6 .A straightedge and compass were used to create the construction below. Arc  $EF$  was drawn from point  $B$ , and arcs with equal radii were drawn from  $E$  and  $F$ .

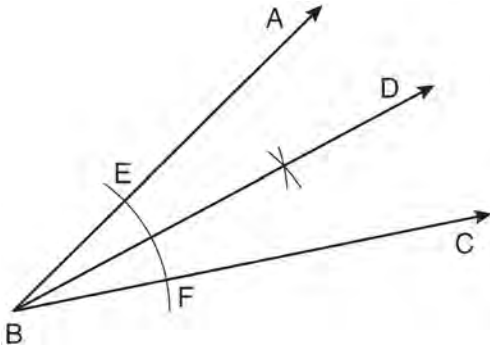

Which statement is *false*?

- 1)  $m\angle ABD = m\angle DBC$
  - 2)  $\frac{1}{2}(m\angle ABC) = m\angle ABD$
  - 3)  $2(m\angle DBC) = m\angle ABC$
  - 4)  $2(m\angle ABC) = m\angle CBD$
- 7 What is the length of the line segment whose endpoints are  $(1, -4)$  and  $(9, 2)$ ?
- 1) 5
  - 2)  $2\sqrt{17}$
  - 3) 10
  - 4)  $2\sqrt{26}$
- 8 What is the image of the point  $(2, -3)$  after the transformation  $r_{y\text{-axis}}$ ?
- 1)  $(2, 3)$
  - 2)  $(-2, -3)$
  - 3)  $(-2, 3)$
  - 4)  $(-3, 2)$

- 9 In the diagram below, lines  $n$  and  $m$  are cut by transversals  $p$  and  $q$ .

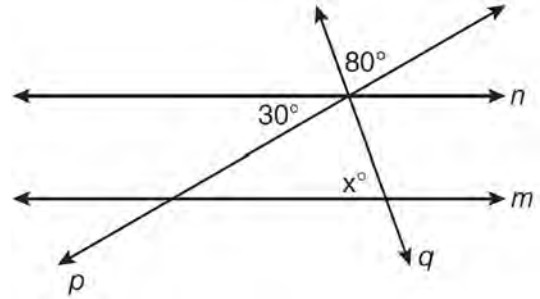

What value of  $x$  would make lines  $n$  and  $m$  parallel?

- 1) 110
  - 2) 80
  - 3) 70
  - 4) 50
- 10 What is an equation of the circle with a radius of 5 and center at  $(1, -4)$ ?
- 1)  $(x + 1)^2 + (y - 4)^2 = 5$
  - 2)  $(x - 1)^2 + (y + 4)^2 = 5$
  - 3)  $(x + 1)^2 + (y - 4)^2 = 25$
  - 4)  $(x - 1)^2 + (y + 4)^2 = 25$
- 11 In the diagram below of  $\triangle BCD$ , side  $\overline{DB}$  is extended to point  $A$ .

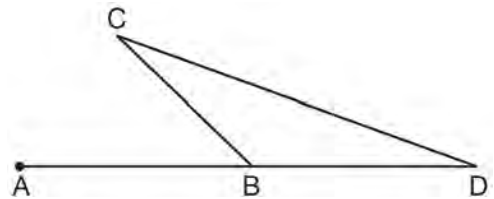

Which statement must be true?

- 1)  $m\angle C > m\angle D$
- 2)  $m\angle ABC < m\angle D$
- 3)  $m\angle ABC > m\angle C$
- 4)  $m\angle ABC > m\angle C + m\angle D$

12 Which equation represents the line parallel to the line whose equation is  $4x + 2y = 14$  and passing through the point  $(2,2)$ ?

- 1)  $y = -2x$
- 2)  $y = -2x + 6$
- 3)  $y = \frac{1}{2}x$
- 4)  $y = \frac{1}{2}x + 1$

13 The coordinates of point  $A$  are  $(-3a, 4b)$ . If point  $A'$  is the image of point  $A$  reflected over the line  $y = x$ , the coordinates of  $A'$  are

- 1)  $(4b, -3a)$
- 2)  $(3a, 4b)$
- 3)  $(-3a, -4b)$
- 4)  $(-4b, -3a)$

14 As shown in the diagram below,  $\overline{AC}$  bisects  $\angle BAD$  and  $\angle B \cong \angle D$ .

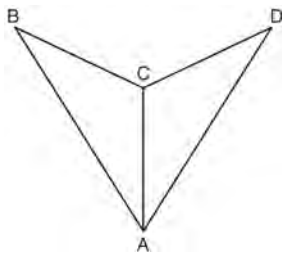

Which method could be used to prove  $\triangle ABC \cong \triangle ADC$ ?

- 1) SSS
- 2) AAA
- 3) SAS
- 4) AAS

15 Segment  $AB$  is the diameter of circle  $M$ . The coordinates of  $A$  are  $(-4, 3)$ . The coordinates of  $M$  are  $(1, 5)$ . What are the coordinates of  $B$ ?

- 1)  $(6, 7)$
- 2)  $(5, 8)$
- 3)  $(-3, 8)$
- 4)  $(-5, 2)$

16 In the diagram below,  $\overleftrightarrow{AB}$  is perpendicular to plane  $AEFG$ .

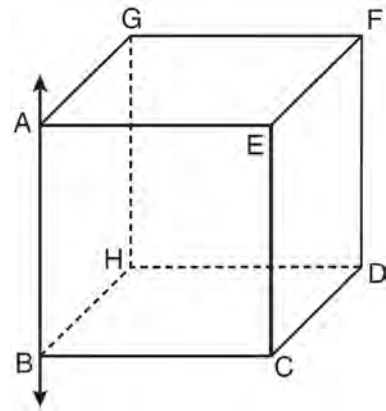

Which plane must be perpendicular to plane  $AEFG$ ?

- 1)  $ABCE$
- 2)  $BCDH$
- 3)  $CDFE$
- 4)  $HDFG$

17 How many points are both 4 units from the origin and also 2 units from the line  $y = 4$ ?

- 1) 1
- 2) 2
- 3) 3
- 4) 4

18 When solved graphically, what is the solution to the following system of equations?

$$y = x^2 - 4x + 6$$

$$y = x + 2$$

- 1)  $(1, 4)$
- 2)  $(4, 6)$
- 3)  $(1, 3)$  and  $(4, 6)$
- 4)  $(3, 1)$  and  $(6, 4)$

19 Triangle  $PQR$  has angles in the ratio of  $2:3:5$ . Which type of triangle is  $\triangle PQR$ ?

- 1) acute
- 2) isosceles
- 3) obtuse
- 4) right

- 20 Plane  $\mathcal{A}$  is parallel to plane  $\mathcal{B}$ . Plane  $\mathcal{C}$  intersects plane  $\mathcal{A}$  in line  $m$  and intersects plane  $\mathcal{B}$  in line  $n$ .

Lines  $m$  and  $n$  are

- 1) intersecting
  - 2) parallel
  - 3) perpendicular
  - 4) skew
- 21 The diagonals of a quadrilateral are congruent but do not bisect each other. This quadrilateral is
- 1) an isosceles trapezoid
  - 2) a parallelogram
  - 3) a rectangle
  - 4) a rhombus

- 22 What is the slope of a line that is perpendicular to the line represented by the equation  $x + 2y = 3$ ?

- 1)  $-2$
- 2)  $2$
- 3)  $-\frac{1}{2}$
- 4)  $\frac{1}{2}$

- 23 A packing carton in the shape of a triangular prism is shown in the diagram below.

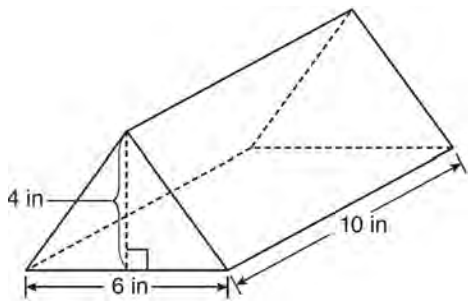

What is the volume, in cubic inches, of this carton?

- 1) 20
- 2) 60
- 3) 120
- 4) 240

- 24 In the diagram below of circle  $O$ , diameter  $\overline{AOB}$  is perpendicular to chord  $\overline{CD}$  at point  $E$ ,  $OA = 6$ , and  $OE = 2$ .

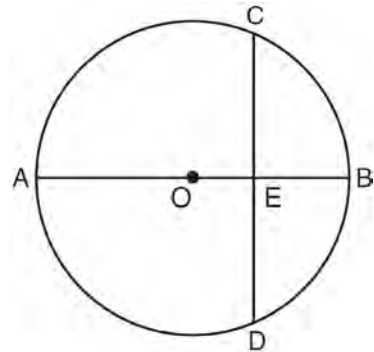

What is the length of  $\overline{CE}$ ?

- 1)  $4\sqrt{3}$
  - 2)  $2\sqrt{3}$
  - 3)  $8\sqrt{2}$
  - 4)  $4\sqrt{2}$
- 25 What is the measure of each interior angle of a regular hexagon?
- 1)  $60^\circ$
  - 2)  $120^\circ$
  - 3)  $135^\circ$
  - 4)  $270^\circ$
- 26 Which equation represents the perpendicular bisector of  $\overline{AB}$  whose endpoints are  $A(8,2)$  and  $B(0,6)$ ?

- 1)  $y = 2x - 4$
- 2)  $y = -\frac{1}{2}x + 2$
- 3)  $y = -\frac{1}{2}x + 6$
- 4)  $y = 2x - 12$

- 27 As shown in the diagram below, a kite needs a vertical and a horizontal support bar attached at opposite corners. The upper edges of the kite are 7 inches, the side edges are  $x$  inches, and the vertical support bar is  $(x + 1)$  inches.

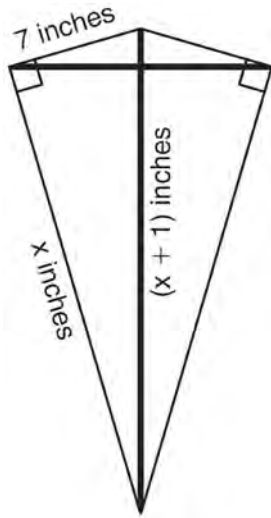

What is the measure, in inches, of the vertical support bar?

- 1) 23
  - 2) 24
  - 3) 25
  - 4) 26
- 28 Given three distinct quadrilaterals, a square, a rectangle, and a rhombus, which quadrilaterals must have perpendicular diagonals?
- 1) the rhombus, only
  - 2) the rectangle and the square
  - 3) the rhombus and the square
  - 4) the rectangle, the rhombus, and the square

- 29 In the diagram below, trapezoid  $ABCD$ , with bases  $\overline{AB}$  and  $\overline{DC}$ , is inscribed in circle  $O$ , with diameter  $\overline{DC}$ . If  $m\widehat{AB}=80$ , find  $m\widehat{BC}$ .

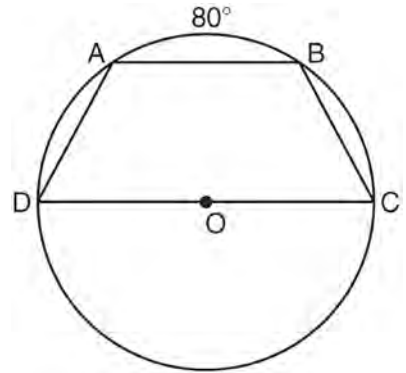

- 30 On the diagram of  $\triangle ABC$  shown below, use a compass and straightedge to construct the perpendicular bisector of  $\overline{AC}$ . [Leave all construction marks.]

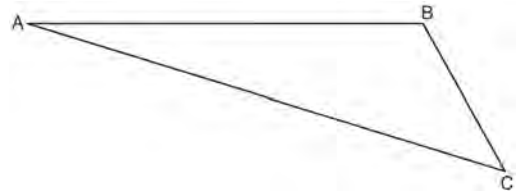

- 31 A sphere has a diameter of 18 meters. Find the volume of the sphere, in cubic meters, in terms of  $\pi$ .

- 32 Write an equation of the circle graphed in the diagram below.

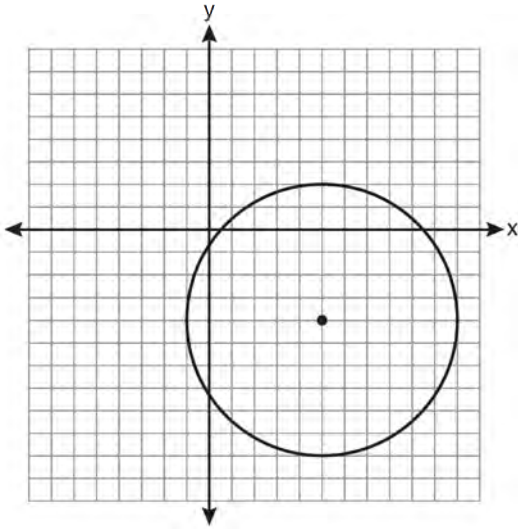

- 33 The diagram below shows  $\triangle ABC$ , with  $\overline{AEB}$ ,  $\overline{ADC}$ , and  $\angle ACB \cong \angle AED$ . Prove that  $\triangle ABC$  is similar to  $\triangle ADE$ .

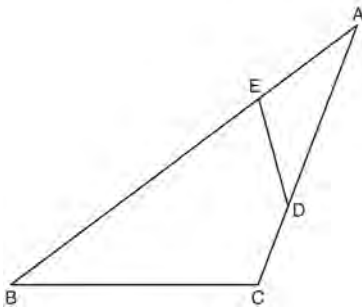

- 34 Triangle  $ABC$  has vertices  $A(3,3)$ ,  $B(7,9)$ , and  $C(11,3)$ . Determine the point of intersection of the medians, and state its coordinates. [The use of the set of axes below is optional.]

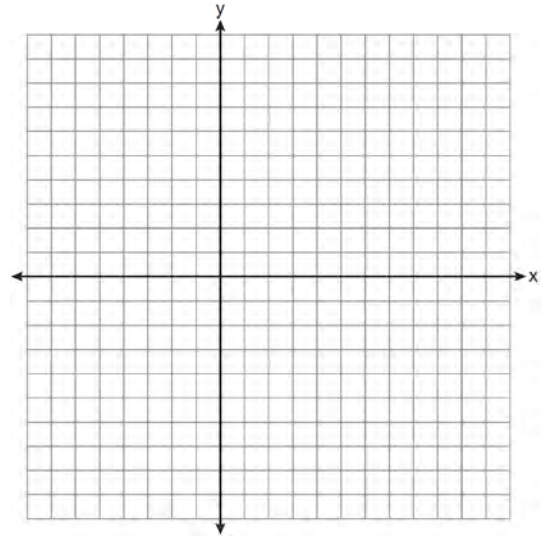

- 35 In the diagram below of  $\triangle GJK$ ,  $H$  is a point on  $\overline{GJ}$ ,  $\overline{HJ} \cong \overline{JK}$ ,  $m\angle G = 28$ , and  $m\angle GJK = 70$ . Determine whether  $\triangle GHK$  is an isosceles triangle and justify your answer.

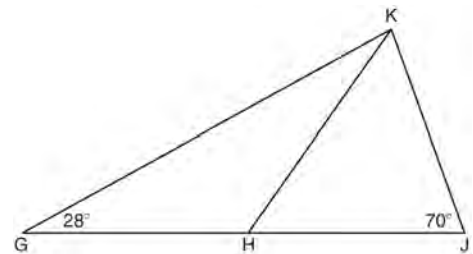

- 36 As shown on the set of axes below,  $\triangle GHS$  has vertices  $G(3,1)$ ,  $H(5,3)$ , and  $S(1,4)$ . Graph and state the coordinates of  $\triangle G''H''S''$ , the image of  $\triangle GHS$  after the transformation  $T_{-3,1} \circ D_2$ .

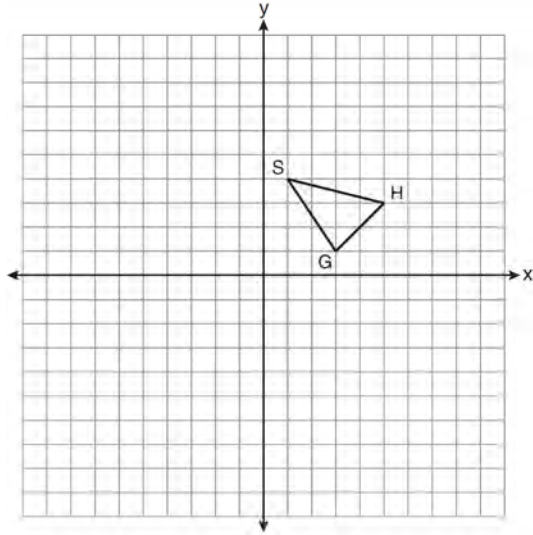

- 38 Given:  $\triangle ABC$  with vertices  $A(-6,-2)$ ,  $B(2,8)$ , and  $C(6,-2)$ .  $\overline{AB}$  has midpoint  $D$ ,  $\overline{BC}$  has midpoint  $E$ , and  $\overline{AC}$  has midpoint  $F$ .

Prove:  $ADEF$  is a parallelogram

$ADEF$  is *not* a rhombus

[The use of the grid is optional.]

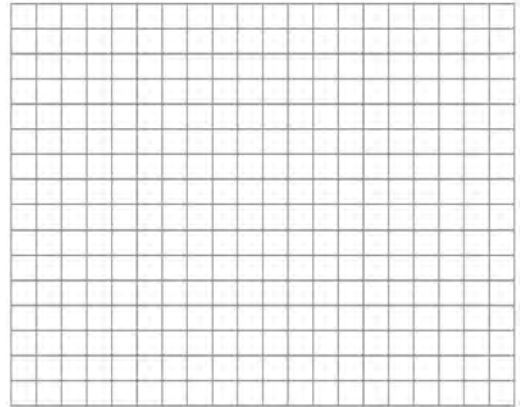

- 37 In the diagram below,  $\triangle ABC \sim \triangle DEF$ ,  $DE = 4$ ,  $AB = x$ ,  $AC = x + 2$ , and  $DF = x + 6$ . Determine the length of  $\overline{AB}$ . [Only an algebraic solution can receive full credit.]

