

JEFFERSON MATH PROJECT REGENTS AT RANDOM

The NY Geometry Regents Exams
Fall 2008-August 2011

www.jmap.org

Dear Sir

I have to acknowledge the receipt of your favor of May 14. in which you mention that you have finished the 6. first books of Euclid, plane trigonometry, surveying & algebra and ask whether I think a further pursuit of that branch of science would be useful to you. there are some propositions in the latter books of Euclid, & some of Archimedes, which are useful, & I have no doubt you have been made acquainted with them. trigonometry, so far as this, is most valuable to every man, there is scarcely a day in which he will not resort to it for some of the purposes of common life. the science of calculation also is indispensable as far as the extraction of the square & cube roots; Algebra as far as the quadratic equation & the use of logarithms are often of value in ordinary cases: but all beyond these is but a luxury; a delicious luxury indeed; but not to be indulged in by one who is to have a profession to follow for his subsistence. in this light I view the conic sections, curves of the higher orders, perhaps even spherical trigonometry, Algebraical operations beyond the 2d dimension, and fluxions.

Letter from Thomas Jefferson to William G. Munford, Monticello, June 18, 1799.

Geometry Regents at Random

- 1 Using a compass and straightedge, construct a line that passes through point P and is perpendicular to line m . [Leave all construction marks.]

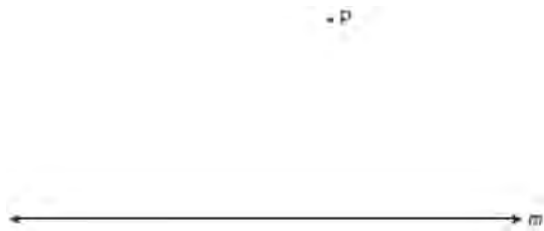

- 2 Which quadrilateral has diagonals that always bisect its angles and also bisect each other?
- 1) rhombus
 - 2) rectangle
 - 3) parallelogram
 - 4) isosceles trapezoid
- 3 What is the negation of the statement “I am not going to eat ice cream”?
- 1) I like ice cream.
 - 2) I am going to eat ice cream.
 - 3) If I eat ice cream, then I like ice cream.
 - 4) If I don't like ice cream, then I don't eat ice cream.

- 4 When $\triangle ABC$ is dilated by a scale factor of 2, its image is $\triangle A'B'C'$. Which statement is true?
- 1) $\overline{AC} \cong \overline{A'C'}$
 - 2) $\angle A \cong \angle A'$
 - 3) perimeter of $\triangle ABC =$ perimeter of $\triangle A'B'C'$
 - 4) $2(\text{area of } \triangle ABC) = \text{area of } \triangle A'B'C'$

- 5 In $\triangle ABC$, $m\angle A = x$, $m\angle B = 2x + 2$, and $m\angle C = 3x + 4$. What is the value of x ?
- 1) 29
 - 2) 31
 - 3) 59
 - 4) 61

- 6 In the diagram below, quadrilateral $JUMP$ is inscribed in a circle..

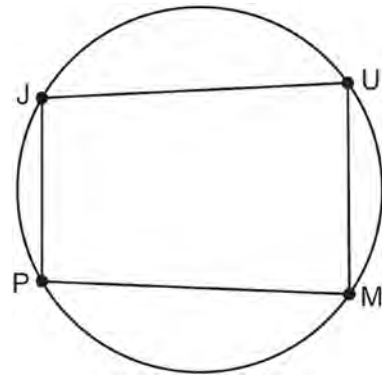

- Opposite angles J and M must be
- 1) right
 - 2) complementary
 - 3) congruent
 - 4) supplementary

- 7 Tim has a rectangular prism with a length of 10 centimeters, a width of 2 centimeters, and an unknown height. He needs to build another rectangular prism with a length of 5 centimeters and the same height as the original prism. The volume of the two prisms will be the same. Find the width, in centimeters, of the new prism.

- 8 What is the distance between the points $(-3,2)$ and $(1,0)$?

- 1) $2\sqrt{2}$
- 2) $2\sqrt{3}$
- 3) $5\sqrt{2}$
- 4) $2\sqrt{5}$

- 9 In the diagram below of circle O , radius \overline{OC} is 5 cm. Chord \overline{AB} is 8 cm and is perpendicular to \overline{OC} at point P .

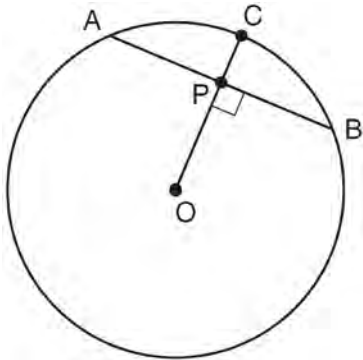

What is the length of \overline{OP} , in centimeters?

- 1) 8
- 2) 2
- 3) 3
- 4) 4

- 10 In the diagram below of $\triangle ABC$, \overline{CD} is the bisector of $\angle BCA$, \overline{AE} is the bisector of $\angle CAB$, and \overline{BG} is drawn.

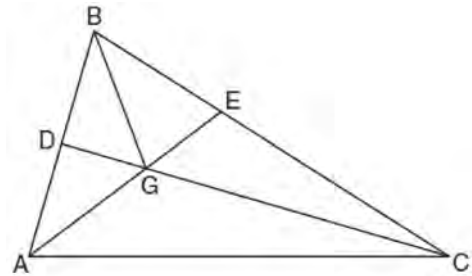

Which statement must be true?

- 1) $DG = EG$
- 2) $AG = BG$
- 3) $\angle AEB \cong \angle AEC$
- 4) $\angle DBG \cong \angle EBG$

- 11 Which equation represents the circle whose center is $(-2,3)$ and whose radius is 5?

- 1) $(x-2)^2 + (y+3)^2 = 5$
- 2) $(x+2)^2 + (y-3)^2 = 5$
- 3) $(x+2)^2 + (y-3)^2 = 25$
- 4) $(x-2)^2 + (y+3)^2 = 25$

- 12 A line segment has endpoints $A(7,-1)$ and $B(-3,3)$. What are the coordinates of the midpoint of \overline{AB} ?

- 1) $(1,2)$
- 2) $(2,1)$
- 3) $(-5,2)$
- 4) $(5,-2)$

Geometry Regents Exam Questions at Random

www.jmap.org

- 13 In plane \mathcal{P} , lines m and n intersect at point A . If line k is perpendicular to line m and line n at point A , then line k is
- 1) contained in plane \mathcal{P}
 - 2) parallel to plane \mathcal{P}
 - 3) perpendicular to plane \mathcal{P}
 - 4) skew to plane \mathcal{P}

- 14 In $\triangle RST$, $m\angle RST = 46$ and $\overline{RS} \cong \overline{ST}$. Find $m\angle STR$.

- 15 The volume, in cubic centimeters, of a sphere whose diameter is 6 centimeters is
- 1) 12π
 - 2) 36π
 - 3) 48π
 - 4) 288π

- 16 Given: \overline{JKLM} is a parallelogram.
 $\overline{JM} \cong \overline{LN}$
 $\angle LMN \cong \angle LNM$
 Prove: \overline{JKLM} is a rhombus.

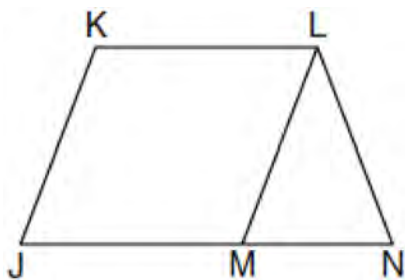

- 17 Triangle ABC has vertices $A(-2,2)$, $B(-1,-3)$, and $C(4,0)$. Find the coordinates of the vertices of $\triangle A'B'C'$, the image of $\triangle ABC$ after the transformation $r_{x\text{-axis}}$. [The use of the grid is optional.]

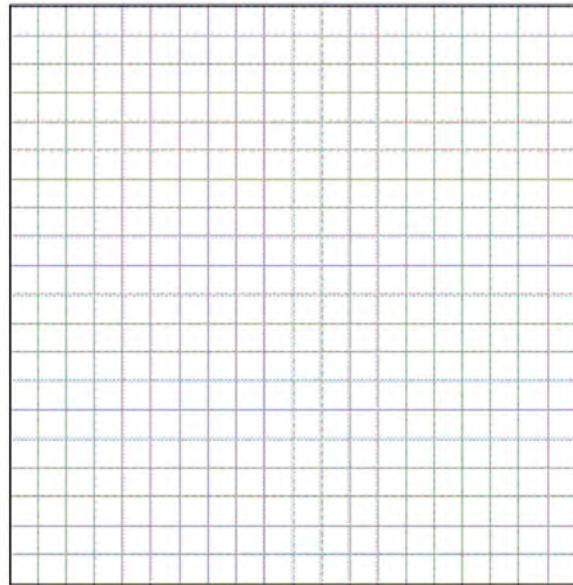

- 18 Point P is on line m . What is the total number of planes that are perpendicular to line m and pass through point P ?
- 1) 1
 - 2) 2
 - 3) 0
 - 4) infinite

- 19 Find, in degrees, the measures of both an interior angle and an exterior angle of a regular pentagon.

- 20 The equation of a circle is $(x - 2)^2 + (y + 4)^2 = 4$.
Which diagram is the graph of the circle?

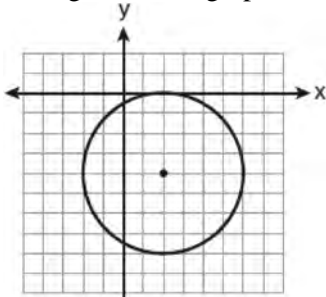

1)

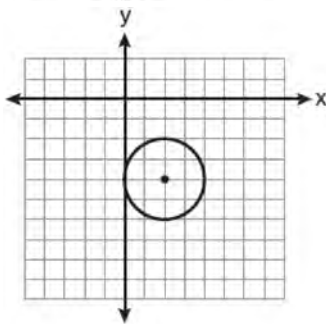

2)

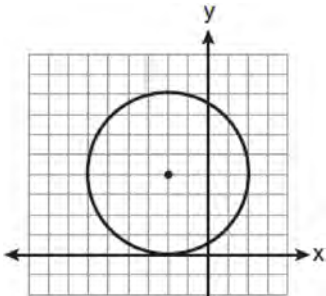

3)

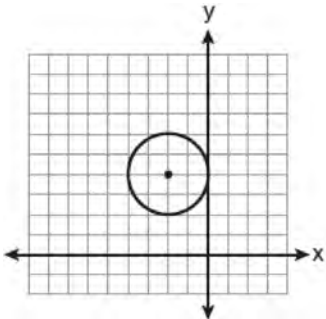

4)

- 21 In the diagram below of circle O , secant \overline{AB} intersects circle O at D , secant \overline{AOC} intersects circle O at E , $AE = 4$, $AB = 12$, and $DB = 6$.

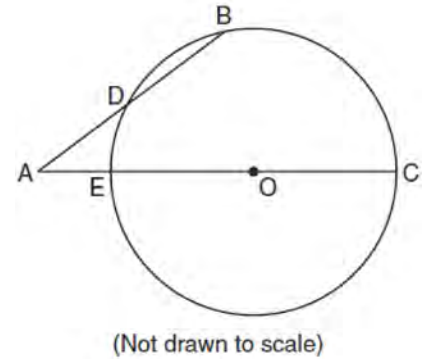

What is the length of \overline{OC} ?

- 1) 4.5
2) 7
3) 9
4) 14
- 22 What is the slope of a line that is perpendicular to the line whose equation is $3x + 4y = 12$?
- 1) $\frac{3}{4}$
2) $-\frac{3}{4}$
3) $\frac{4}{3}$
4) $-\frac{4}{3}$
- 23 If the diagonals of a quadrilateral do *not* bisect each other, then the quadrilateral could be a
- 1) rectangle
2) rhombus
3) square
4) trapezoid

- 24 Which geometric principle is used to justify the construction below?

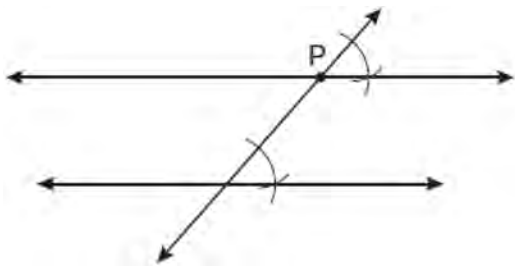

- 1) A line perpendicular to one of two parallel lines is perpendicular to the other.
- 2) Two lines are perpendicular if they intersect to form congruent adjacent angles.
- 3) When two lines are intersected by a transversal and alternate interior angles are congruent, the lines are parallel.
- 4) When two lines are intersected by a transversal and the corresponding angles are congruent, the lines are parallel.

- 25 Given: $y = \frac{1}{4}x - 3$

$$y = x^2 + 8x + 12$$

In which quadrant will the graphs of the given equations intersect?

- 1) I
 - 2) II
 - 3) III
 - 4) IV
- 26 The point $(3, -2)$ is rotated 90° about the origin and then dilated by a scale factor of 4. What are the coordinates of the resulting image?
- 1) $(-12, 8)$
 - 2) $(12, -8)$
 - 3) $(8, 12)$
 - 4) $(-8, -12)$

- 27 On the grid below, graph the points that are equidistant from both the x and y axes and the points that are 5 units from the origin. Label with an **X** all points that satisfy *both* conditions.

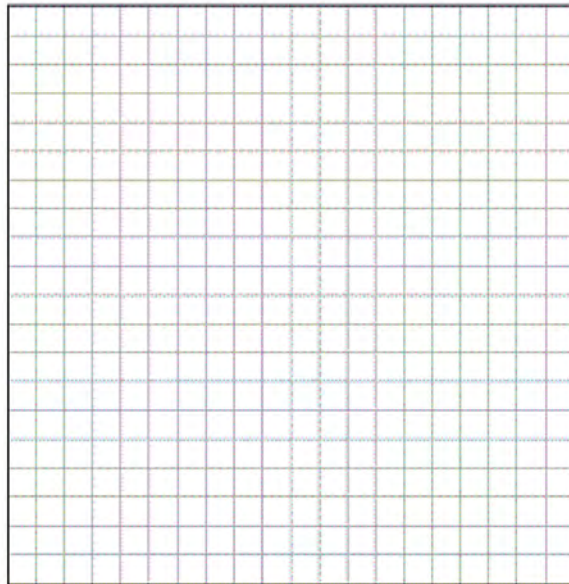

- 28 In the diagram below, quadrilateral $STAR$ is a rhombus with diagonals \overline{SA} and \overline{TR} intersecting at E . $ST = 3x + 30$, $SR = 8x - 5$, $SE = 3z$, $TE = 5z + 5$, $AE = 4z - 8$, $m\angle RTA = 5y - 2$, and $m\angle TAS = 9y + 8$. Find SR , RT , and $m\angle TAS$.

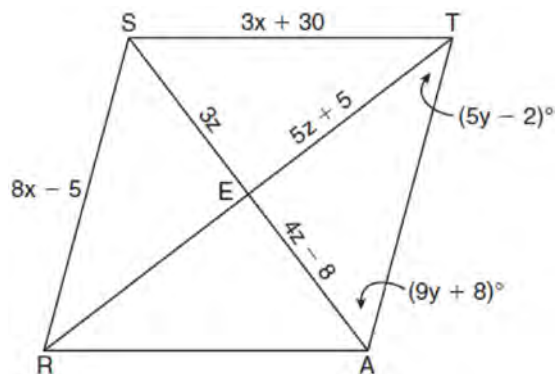

Geometry Regents Exam Questions at Random

www.jmap.org

29 Point A is located at $(4, -7)$. The point is reflected in the x -axis. Its image is located at

- 1) $(-4, 7)$
- 2) $(-4, -7)$
- 3) $(4, 7)$
- 4) $(7, -4)$

30 What is the length, to the *nearest tenth*, of the line segment joining the points $(-4, 2)$ and $(146, 52)$?

- 1) 141.4
- 2) 150.5
- 3) 151.9
- 4) 158.1

31 In $\triangle ABC$, point D is on \overline{AB} , and point E is on \overline{BC} such that $\overline{DE} \parallel \overline{AC}$. If $DB = 2$, $DA = 7$, and

$DE = 3$, what is the length of \overline{AC} ?

- 1) 8
- 2) 9
- 3) 10.5
- 4) 13.5

32 Given the true statement, "The medians of a triangle are concurrent," write the negation of the statement and give the truth value for the negation.

33 Find an equation of the line passing through the point $(5, 4)$ and parallel to the line whose equation is $2x + y = 3$.

34 The coordinates of the vertices of parallelogram $ABCD$ are $A(-2, 2)$, $B(3, 5)$, $C(4, 2)$, and $D(-1, -1)$. State the coordinates of the vertices of parallelogram $A''B''C''D''$ that result from the transformation $r_{y\text{-axis}} \circ T_{2, -3}$. [The use of the set of axes below is optional.]

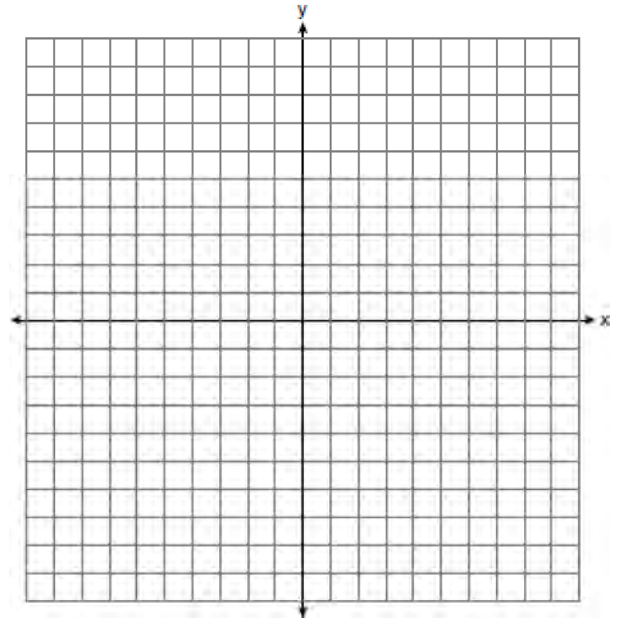

35 What is an equation of the line that passes through the point $(-2, 3)$ and is parallel to the line whose equation is $y = \frac{3}{2}x - 4$?

- 1) $y = \frac{-2}{3}x$
- 2) $y = \frac{-2}{3}x + \frac{5}{3}$
- 3) $y = \frac{3}{2}x$
- 4) $y = \frac{3}{2}x + 6$

- 36 In the diagram below of $\triangle TEM$, medians \overline{TB} , \overline{EC} , and \overline{MA} intersect at D , and $TB = 9$. Find the length of \overline{TD} .

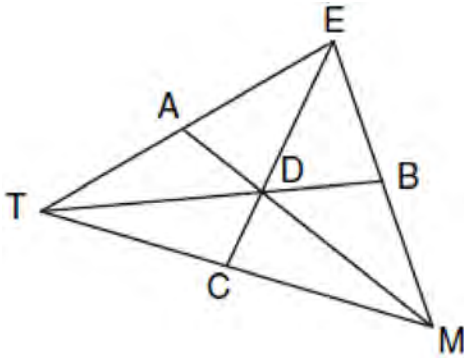

- 37 The diagram below shows the construction of a line through point P perpendicular to line m .

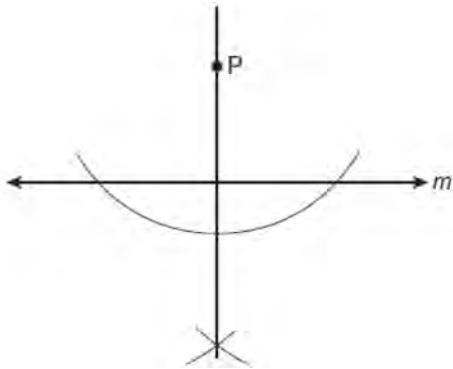

Which statement is demonstrated by this construction?

- 1) If a line is parallel to a line that is perpendicular to a third line, then the line is also perpendicular to the third line.
- 2) The set of points equidistant from the endpoints of a line segment is the perpendicular bisector of the segment.
- 3) Two lines are perpendicular if they are equidistant from a given point.
- 4) Two lines are perpendicular if they intersect to form a vertical line.

- 38 What is an equation for the circle shown in the graph below?

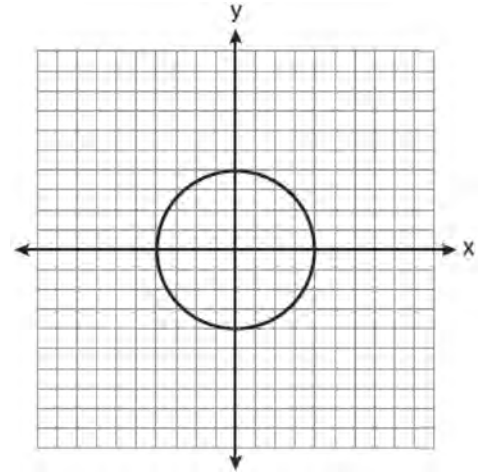

- 1) $x^2 + y^2 = 2$
- 2) $x^2 + y^2 = 4$
- 3) $x^2 + y^2 = 8$
- 4) $x^2 + y^2 = 16$

- 39 In the diagram below of rhombus $ABCD$, $m\angle C = 100$.

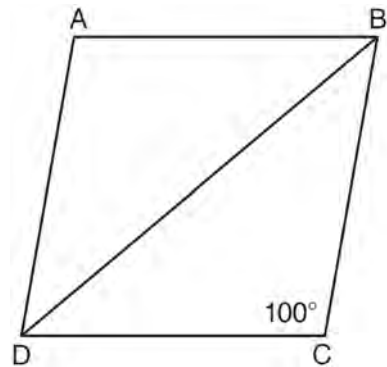

What is $m\angle DBC$?

- 1) 40
- 2) 45
- 3) 50
- 4) 80

- 40 What is the image of point $A(4,2)$ after the composition of transformations defined by $R_{90^\circ} \circ r_{y=x}$?
- 1) $(-4,2)$
 - 2) $(4,-2)$
 - 3) $(-4,-2)$
 - 4) $(2,-4)$

- 41 The coordinates of the vertices of parallelogram $ABCD$ are $A(-3,2)$, $B(-2,-1)$, $C(4,1)$, and $D(3,4)$. The slopes of which line segments could be calculated to show that $ABCD$ is a rectangle?
- 1) \overline{AB} and \overline{DC}
 - 2) \overline{AB} and \overline{BC}
 - 3) \overline{AD} and \overline{BC}
 - 4) \overline{AC} and \overline{BD}

- 42 Which equation represents a line parallel to the line whose equation is $2y - 5x = 10$?
- 1) $5y - 2x = 25$
 - 2) $5y + 2x = 10$
 - 3) $4y - 10x = 12$
 - 4) $2y + 10x = 8$

- 43 In $\triangle PQR$, $PQ = 8$, $QR = 12$, and $RP = 13$. Which statement about the angles of $\triangle PQR$ must be true?
- 1) $m\angle Q > m\angle P > m\angle R$
 - 2) $m\angle Q > m\angle R > m\angle P$
 - 3) $m\angle R > m\angle P > m\angle Q$
 - 4) $m\angle P > m\angle R > m\angle Q$

- 44 In the diagram below of $\triangle ABC$, side \overline{BC} is extended to point D , $m\angle A = x$, $m\angle B = 2x + 15$, and $m\angle ACD = 5x + 5$.

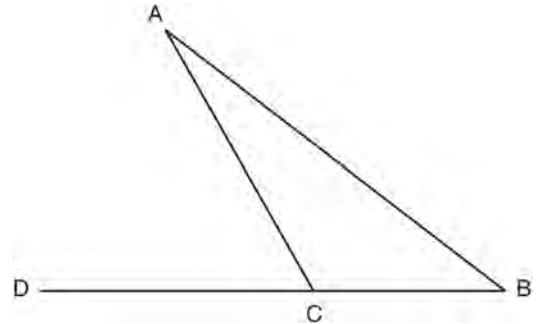

What is $m\angle B$?

- 1) 5
 - 2) 20
 - 3) 25
 - 4) 55
- 45 Two lines, \overleftrightarrow{AB} and \overleftrightarrow{CRD} , are parallel and 10 inches apart. Sketch the locus of all points that are equidistant from \overleftrightarrow{AB} and \overleftrightarrow{CRD} and 7 inches from point R . Label with an **X** each point that satisfies both conditions.

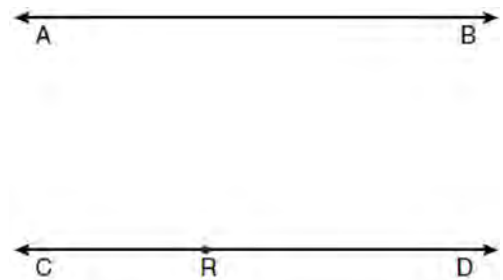

- 46 Which graph represents a circle with the equation $(x - 5)^2 + (y + 1)^2 = 9$?

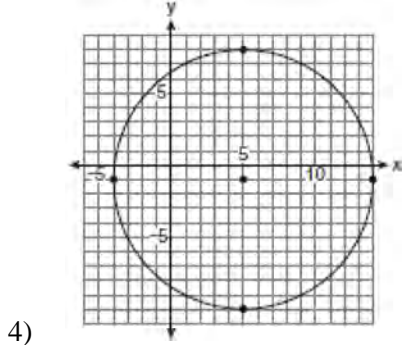
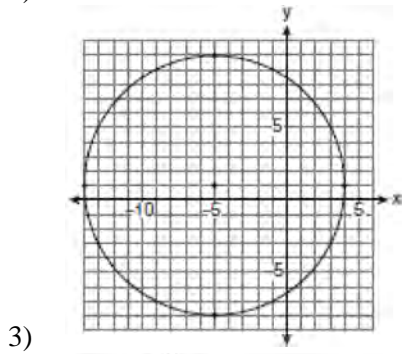
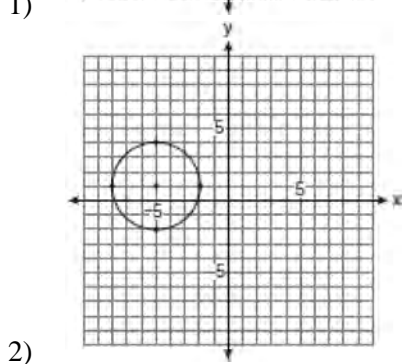
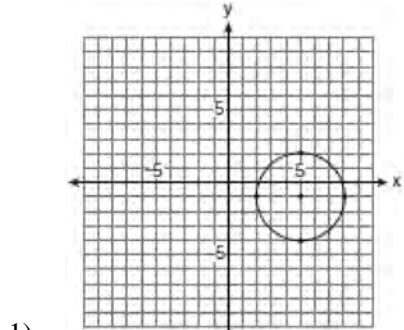

- 47 As shown on the graph below, $\triangle R'S'T'$ is the image of $\triangle RST$ under a single transformation.

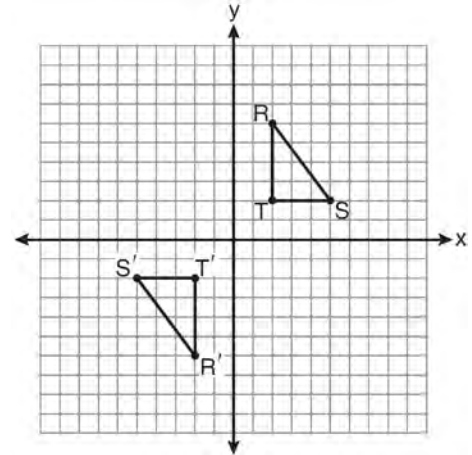

Which transformation does this graph represent?

- 1) glide reflection
 - 2) line reflection
 - 3) rotation
 - 4) translation
- 48 Which set of numbers does *not* represent the sides of a right triangle?
- 1) {6, 8, 10}
 - 2) {8, 15, 17}
 - 3) {8, 24, 25}
 - 4) {15, 36, 39}
- 49 Tim is going to paint a wooden sphere that has a diameter of 12 inches. Find the surface area of the sphere, to the *nearest square inch*.

- 50 In the diagram below of circle O , chord $\overline{AB} \parallel$ chord \overline{CD} , and chord $\overline{CD} \parallel$ chord \overline{EF} .

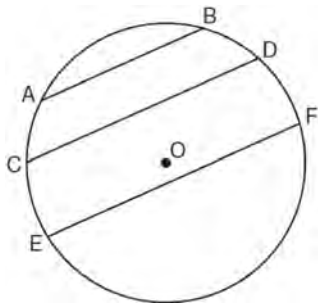

Which statement must be true?

- 1) $\widehat{CE} \cong \widehat{DF}$
 - 2) $\widehat{AC} \cong \widehat{DF}$
 - 3) $\widehat{AC} \cong \widehat{CE}$
 - 4) $\widehat{EF} \cong \widehat{CD}$
- 51 Find an equation of the line passing through the point $(6,5)$ and perpendicular to the line whose equation is $2y + 3x = 6$.

- 52 Given the system of equations:
- $$y = x^2 - 4x$$
- $$x = 4$$

The number of points of intersection is

- 1) 1
- 2) 2
- 3) 3
- 4) 0

- 53 Triangle ABC has coordinates $A(-6,2)$, $B(-3,6)$, and $C(5,0)$. Find the perimeter of the triangle. Express your answer in simplest radical form. [The use of the grid below is optional.]

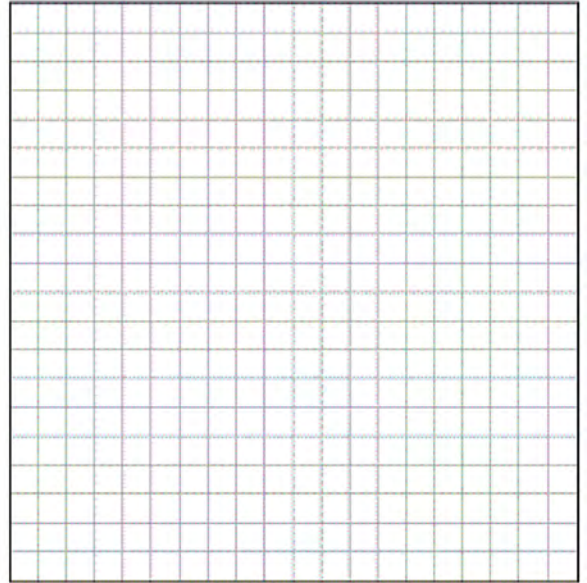

- 54 In the diagram below, \overline{PA} and \overline{PB} are tangent to circle O , \overline{OA} and \overline{OB} are radii, and \overline{OP} intersects the circle at C . Prove: $\angle AOP \cong \angle BOP$

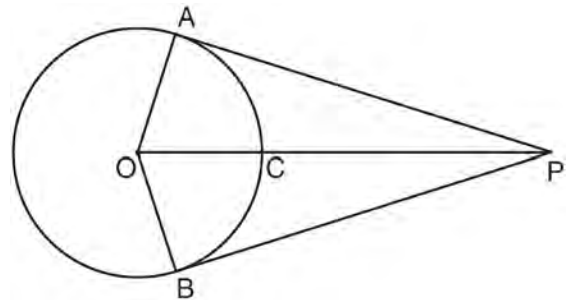

- 55 In the diagram below of parallelogram $STUV$, $SV = x + 3$, $VU = 2x - 1$, and $TU = 4x - 3$.

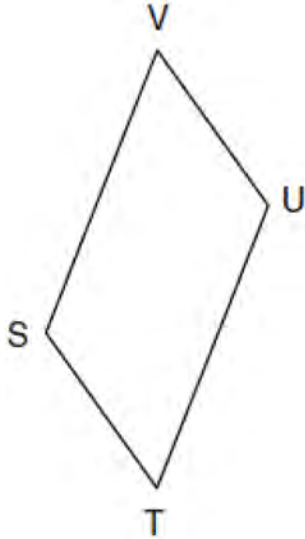

What is the length of \overline{SV} ?

- 1) 5
- 2) 2
- 3) 7
- 4) 4

- 56 In the diagram of circle O below, chords \overline{AB} and \overline{CD} are parallel, and \overline{BD} is a diameter of the circle.

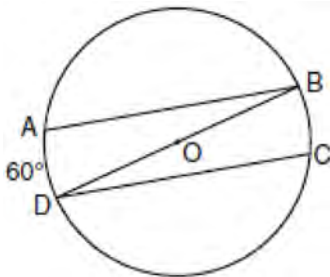

If $m\widehat{AD} = 60$, what is $m\angle CDB$?

- 1) 20
- 2) 30
- 3) 60
- 4) 120

- 57 In the diagram below of $\triangle ACE$, medians \overline{AD} , \overline{EB} , and \overline{CF} intersect at G . The length of \overline{FG} is 12 cm.

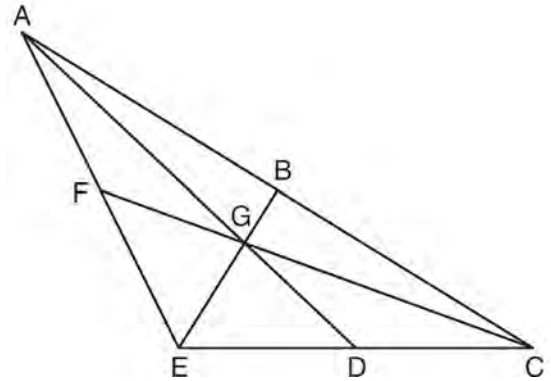

What is the length, in centimeters, of \overline{GC} ?

- 1) 24
- 2) 12
- 3) 6
- 4) 4

- 58 The vertices of the triangle in the diagram below are $A(7,9)$, $B(3,3)$, and $C(11,3)$.

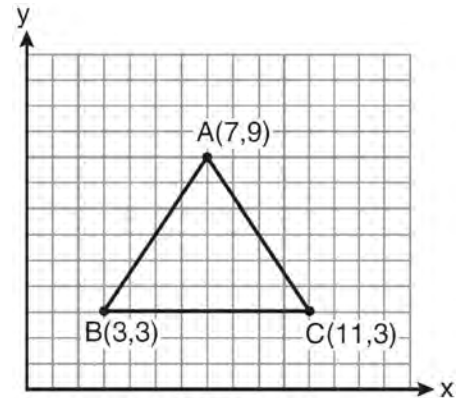

What are the coordinates of the centroid of $\triangle ABC$?

- 1) (5,6)
- 2) (7,3)
- 3) (7,5)
- 4) (9,6)

- 59 After a composition of transformations, the coordinates $A(4,2)$, $B(4,6)$, and $C(2,6)$ become $A''(-2,-1)$, $B''(-2,-3)$, and $C''(-1,-3)$, as shown on the set of axes below.

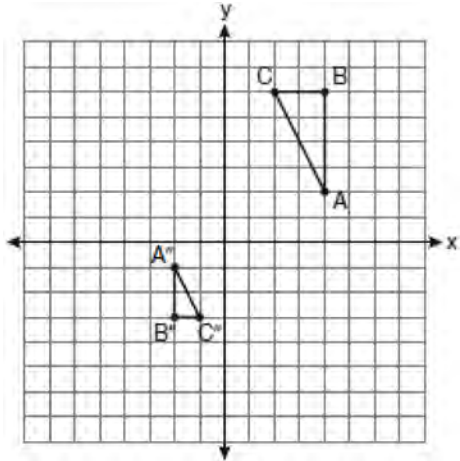

Which composition of transformations was used?

- 1) $R_{180^\circ} \circ D_2$
 - 2) $R_{90^\circ} \circ D_2$
 - 3) $D_{\frac{1}{2}} \circ R_{180^\circ}$
 - 4) $D_{\frac{1}{2}} \circ R_{90^\circ}$
- 60 Using a compass and straightedge, and \overline{AB} below, construct an equilateral triangle with all sides congruent to \overline{AB} . [Leave all construction marks.]



- 61 In the diagram of $\triangle KLM$ below, $m\angle L = 70$, $m\angle M = 50$, and \overline{MK} is extended through N .

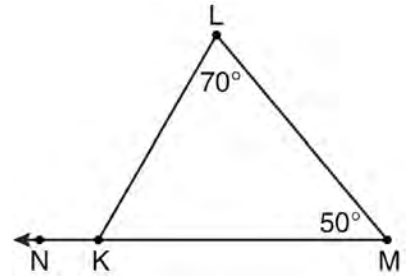

What is the measure of $\angle LKN$?

- 1) 60°
 - 2) 120°
 - 3) 180°
 - 4) 300°
- 62 In the diagram below of $\triangle ABC$, D is the midpoint of \overline{AB} , and E is the midpoint of \overline{BC} .

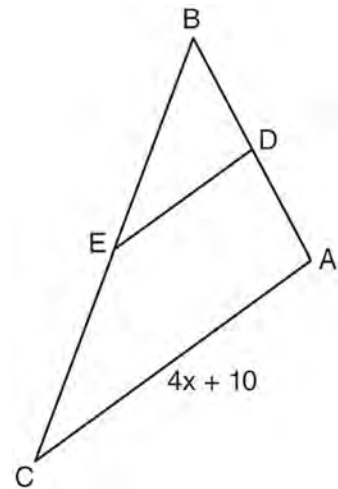

If $AC = 4x + 10$, which expression represents DE ?

- 1) $x + 2.5$
- 2) $2x + 5$
- 3) $2x + 10$
- 4) $8x + 20$

- 63 Write an equation of the circle whose diameter \overline{AB} has endpoints $A(-4,2)$ and $B(4,-4)$. [The use of the grid below is optional.]

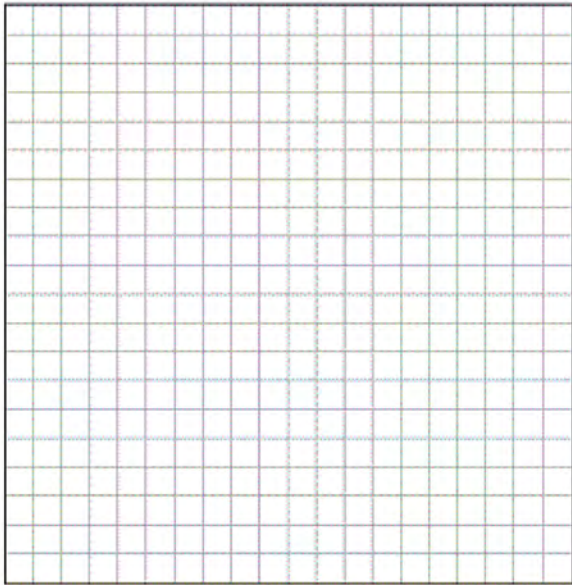

- 64 A pentagon is drawn on the set of axes below. If the pentagon is reflected over the y -axis, determine if this transformation is an isometry. Justify your answer. [The use of the set of axes is optional.]

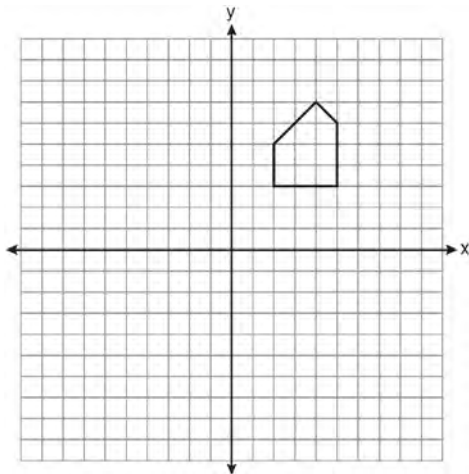

- 65 Point P lies on line m . Point P is also included in distinct planes Q , R , S , and T . At most, how many of these planes could be perpendicular to line m ?
- 1) 1
 - 2) 2
 - 3) 3
 - 4) 4
- 66 Lines m and n intersect at point A . Line k is perpendicular to both lines m and n at point A . Which statement *must* be true?
- 1) Lines m , n , and k are in the same plane.
 - 2) Lines m and n are in two different planes.
 - 3) Lines m and n are perpendicular to each other.
 - 4) Line k is perpendicular to the plane containing lines m and n .
- 67 A right circular cylinder has an altitude of 11 feet and a radius of 5 feet. What is the lateral area, in square feet, of the cylinder, to the *nearest tenth*?
- 1) 172.7
 - 2) 172.8
 - 3) 345.4
 - 4) 345.6
- 68 Through a given point, P , on a plane, how many lines can be drawn that are perpendicular to that plane?
- 1) 1
 - 2) 2
 - 3) more than 2
 - 4) none
- 69 In right $\triangle DEF$, $m\angle D = 90$ and $m\angle F$ is 12 degrees less than twice $m\angle E$. Find $m\angle E$.

- 70 The Parkside Packing Company needs a rectangular shipping box. The box must have a length of 11 inches and a width of 8 inches. Find, to the *nearest tenth of an inch*, the minimum height of the box such that the volume is *at least* 800 cubic inches.

- 71 If $\triangle JKL \cong \triangle MNO$, which statement is always true?

- 1) $\angle KLJ \cong \angle NMO$
- 2) $\angle KJL \cong \angle MON$
- 3) $\overline{JL} \cong \overline{MO}$
- 4) $\overline{JK} \cong \overline{ON}$

- 72 In $\triangle ABC$, $\overline{AB} \cong \overline{BC}$. An altitude is drawn from B to \overline{AC} and intersects \overline{AC} at D . Which conclusion is *not* always true?

- 1) $\angle ABD \cong \angle CBD$
- 2) $\angle BDA \cong \angle BDC$
- 3) $\overline{AD} \cong \overline{BD}$
- 4) $\overline{AD} \cong \overline{DC}$

- 73 In circle O , a diameter has endpoints $(-5,4)$ and $(3,-6)$. What is the length of the diameter?

- 1) $\sqrt{2}$
- 2) $2\sqrt{2}$
- 3) $\sqrt{10}$
- 4) $2\sqrt{41}$

- 74 In isosceles triangle ABC , $AB = BC$. Which statement will always be true?

- 1) $m\angle B = m\angle A$
- 2) $m\angle A > m\angle B$
- 3) $m\angle A = m\angle C$
- 4) $m\angle C < m\angle B$

- 75 In the diagram below of right triangle ABC , altitude \overline{BD} is drawn to hypotenuse \overline{AC} , $AC = 16$, and $CD = 7$.

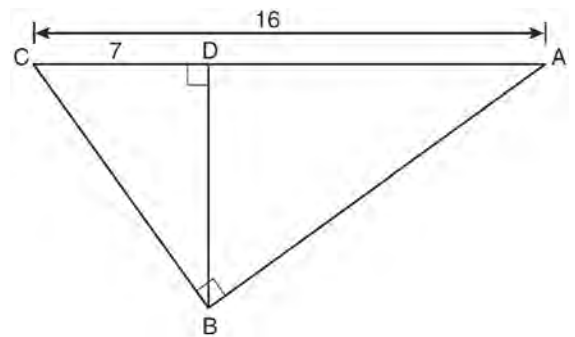

What is the length of \overline{BD} ?

- 1) $3\sqrt{7}$
- 2) $4\sqrt{7}$
- 3) $7\sqrt{3}$
- 4) 12

- 76 In the diagram below of $\triangle ABC$, \overline{DE} is a midsegment of $\triangle ABC$, $DE = 7$, $AB = 10$, and $BC = 13$. Find the perimeter of $\triangle ABC$.

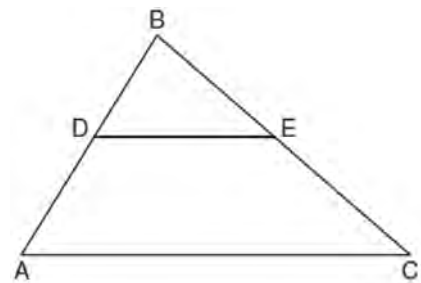

- 77 If two distinct planes, \mathcal{A} and \mathcal{B} , are perpendicular to line c , then which statement is true?
- 1) Planes \mathcal{A} and \mathcal{B} are parallel to each other.
 - 2) Planes \mathcal{A} and \mathcal{B} are perpendicular to each other.
 - 3) The intersection of planes \mathcal{A} and \mathcal{B} is a line parallel to line c .
 - 4) The intersection of planes \mathcal{A} and \mathcal{B} is a line perpendicular to line c .

- 78 A transversal intersects two lines. Which condition would always make the two lines parallel?
- 1) Vertical angles are congruent.
 - 2) Alternate interior angles are congruent.
 - 3) Corresponding angles are supplementary.
 - 4) Same-side interior angles are complementary.

- 79 What is the length of the line segment whose endpoints are $A(-1,9)$ and $B(7,4)$?
- 1) $\sqrt{61}$
 - 2) $\sqrt{89}$
 - 3) $\sqrt{205}$
 - 4) $\sqrt{233}$

- 80 Given: $\triangle ABC$ and $\triangle EDC$, C is the midpoint of \overline{BD} and \overline{AE}
Prove: $\overline{AB} \parallel \overline{DE}$

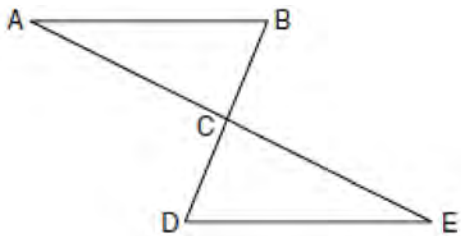

- 81 Two lines are represented by the equations $-\frac{1}{2}y = 6x + 10$ and $y = mx$. For which value of m will the lines be parallel?
- 1) -12
 - 2) -3
 - 3) 3
 - 4) 12

- 82 In $\triangle DEF$, $m\angle D = 3x + 5$, $m\angle E = 4x - 15$, and $m\angle F = 2x + 10$. Which statement is true?
- 1) $DF = FE$
 - 2) $DE = FE$
 - 3) $m\angle E = m\angle F$
 - 4) $m\angle D = m\angle F$

- 83 On the set of axes below, solve the following system of equations graphically for all values of x and y .

$$y = (x - 2)^2 + 4$$

$$4x + 2y = 14$$

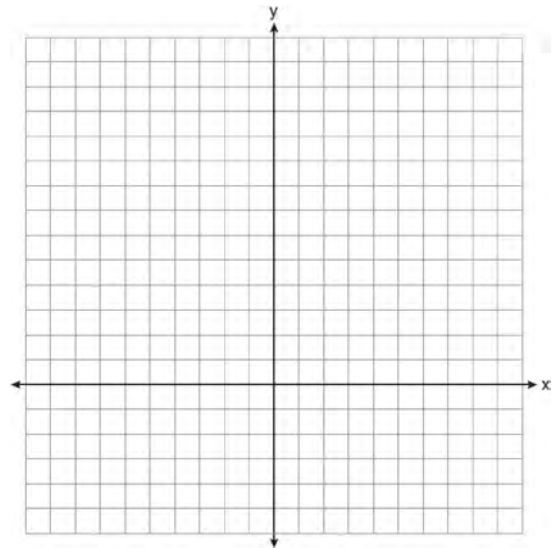

- 84 Which statement is true about every parallelogram?
- 1) All four sides are congruent.
 - 2) The interior angles are all congruent.
 - 3) Two pairs of opposite sides are congruent.
 - 4) The diagonals are perpendicular to each other.

- 85 Solve the following system of equations graphically.

$$2x^2 - 4x = y + 1$$

$$x + y = 1$$

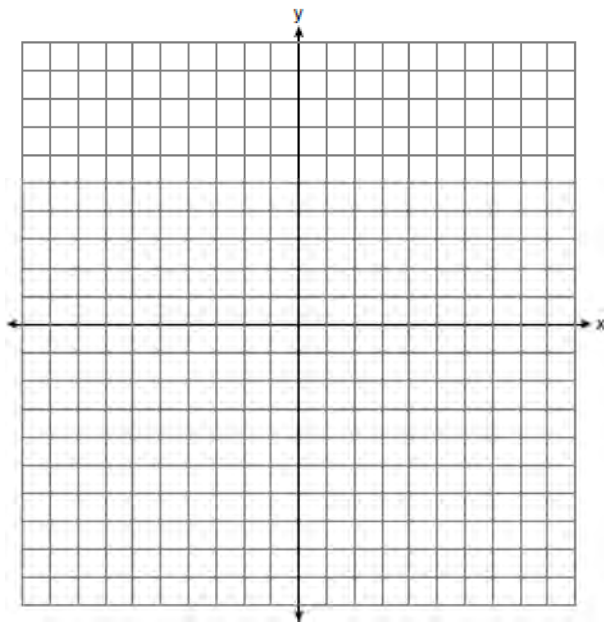

- 86 What is the slope of a line perpendicular to the line whose equation is $y = 3x + 4$?
- 1) $\frac{1}{3}$
 - 2) $-\frac{1}{3}$
 - 3) 3
 - 4) -3

- 87 The diagram below shows \overline{AB} and \overline{DE} .

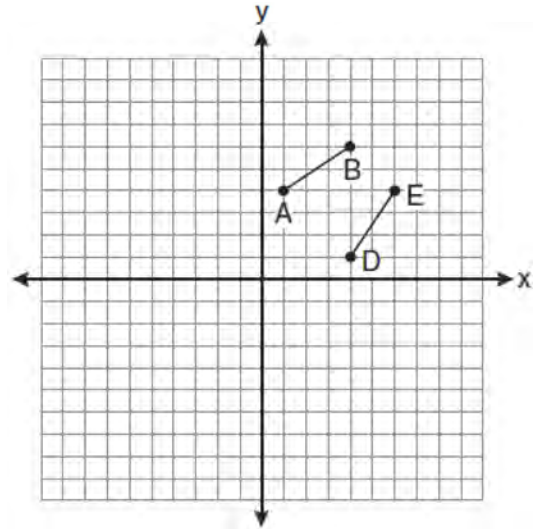

Which transformation will move \overline{AB} onto \overline{DE} such that point D is the image of point A and point E is the image of point B ?

- 1) $T_{3,-3}$
 - 2) $D_{\frac{1}{2}}$
 - 3) R_{90°
 - 4) $r_{y=x}$
- 88 Plane \mathcal{R} is perpendicular to line k and plane \mathcal{D} is perpendicular to line k . Which statement is correct?
- 1) Plane \mathcal{R} is perpendicular to plane \mathcal{D} .
 - 2) Plane \mathcal{R} is parallel to plane \mathcal{D} .
 - 3) Plane \mathcal{R} intersects plane \mathcal{D} .
 - 4) Plane \mathcal{R} bisects plane \mathcal{D} .

- 89 The diagram below shows a pennant in the shape of an isosceles triangle. The equal sides each measure 13, the altitude is $x + 7$, and the base is $2x$.

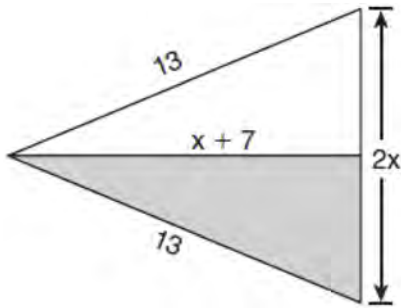

What is the length of the base?

- 1) 5
 - 2) 10
 - 3) 12
 - 4) 24
- 90 The rectangle $ABCD$ shown in the diagram below will be reflected across the x -axis.

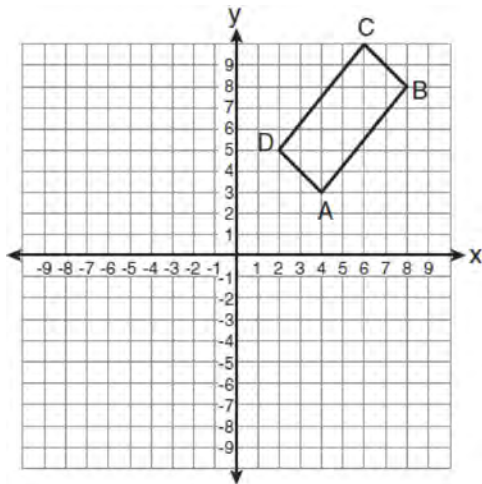

What will *not* be preserved?

- 1) slope of \overline{AB}
- 2) parallelism of \overline{AB} and \overline{CD}
- 3) length of \overline{AB}
- 4) measure of $\angle A$

- 91 What is an equation of the line that contains the point $(3, -1)$ and is perpendicular to the line whose equation is $y = -3x + 2$?

- 1) $y = -3x + 8$
- 2) $y = -3x$
- 3) $y = \frac{1}{3}x$
- 4) $y = \frac{1}{3}x - 2$

- 92 In the diagram below, \overline{SQ} and \overline{PR} intersect at T , \overline{PQ} is drawn, and $\overline{PS} \parallel \overline{QR}$.

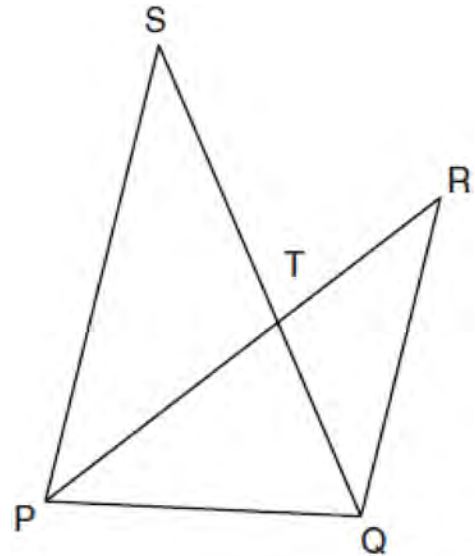

What technique can be used to prove that $\triangle PST \sim \triangle RQT$?

- 1) SAS
- 2) SSS
- 3) ASA
- 4) AA

- 93 In isosceles trapezoid $ABCD$, $\overline{AB} \cong \overline{CD}$. If $BC = 20$, $AD = 36$, and $AB = 17$, what is the length of the altitude of the trapezoid?
- 1) 10
 - 2) 12
 - 3) 15
 - 4) 16

- 94 Towns A and B are 16 miles apart. How many points are 10 miles from town A and 12 miles from town B ?
- 1) 1
 - 2) 2
 - 3) 3
 - 4) 0

- 95 The base of a pyramid is a rectangle with a width of 6 cm and a length of 8 cm. Find, in centimeters, the height of the pyramid if the volume is 288 cm^3 .

- 96 In the diagram of $\triangle ABC$ below, Jose found centroid P by constructing the three medians. He measured CF and found it to be 6 inches.

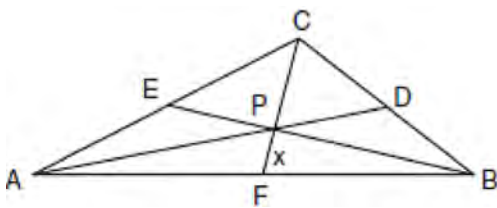

If $PF = x$, which equation can be used to find x ?

- 1) $x + x = 6$
- 2) $2x + x = 6$
- 3) $3x + 2x = 6$
- 4) $x + \frac{2}{3}x = 6$

- 97 In the diagram below, $\triangle ABC$ is shown with \overline{AC} extended through point D .

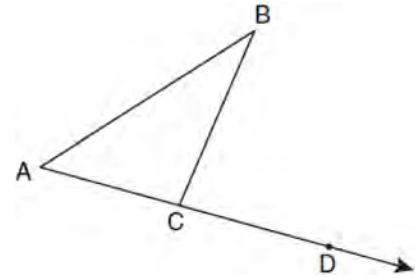

If $m\angle BCD = 6x + 2$, $m\angle BAC = 3x + 15$, and $m\angle ABC = 2x - 1$, what is the value of x ?

- 1) 12
- 2) $14\frac{10}{11}$
- 3) 16
- 4) $18\frac{1}{9}$

- 98 In the diagram below, $\triangle ABC \sim \triangle EFG$, $m\angle C = 4x + 30$, and $m\angle G = 5x + 10$. Determine the value of x .

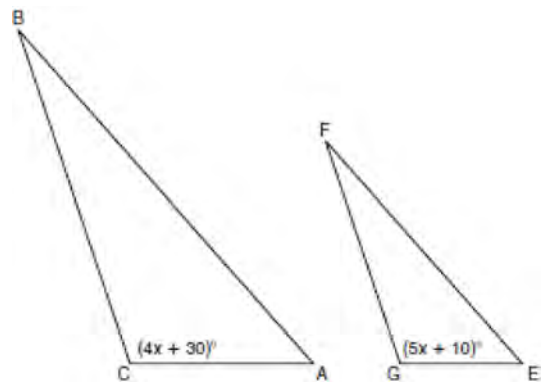

- 99 Juliann plans on drawing $\triangle ABC$, where the measure of $\angle A$ can range from 50° to 60° and the measure of $\angle B$ can range from 90° to 100° . Given these conditions, what is the correct range of measures possible for $\angle C$?
- 1) 20° to 40°
 - 2) 30° to 50°
 - 3) 80° to 90°
 - 4) 120° to 130°

- 100 In the diagram below, a right circular cone has a diameter of 8 inches and a height of 12 inches.

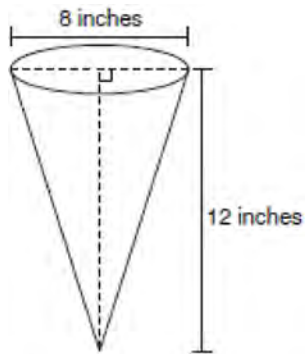

What is the volume of the cone to the *nearest cubic inch*?

- 1) 201
 - 2) 481
 - 3) 603
 - 4) 804
- 101 What is the image of the point $(-5, 2)$ under the translation $T_{3, -4}$?
- 1) $(-9, 5)$
 - 2) $(-8, 6)$
 - 3) $(-2, -2)$
 - 4) $(-15, -8)$

- 102 What is the volume, in cubic centimeters, of a cylinder that has a height of 15 cm and a diameter of 12 cm?
- 1) 180π
 - 2) 540π
 - 3) 675π
 - 4) $2,160\pi$

- 103 In $\triangle ABC$, $m\angle A = 95$, $m\angle B = 50$, and $m\angle C = 35$. Which expression correctly relates the lengths of the sides of this triangle?
- 1) $AB < BC < CA$
 - 2) $AB < AC < BC$
 - 3) $AC < BC < AB$
 - 4) $BC < AC < AB$

- 104 What is an equation of circle O shown in the graph below?

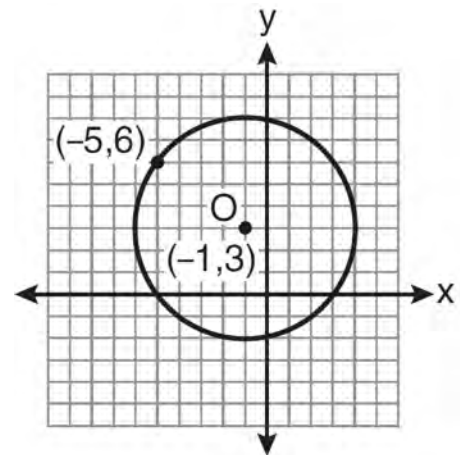

- 1) $(x + 1)^2 + (y - 3)^2 = 25$
- 2) $(x - 1)^2 + (y + 3)^2 = 25$
- 3) $(x - 5)^2 + (y + 6)^2 = 25$
- 4) $(x + 5)^2 + (y - 6)^2 = 25$

- 105 On the set of coordinate axes below, graph the locus of points that are equidistant from the lines $y = 6$ and $y = 2$ and also graph the locus of points that are 3 units from the y -axis. State the coordinates of *all* points that satisfy *both* conditions.

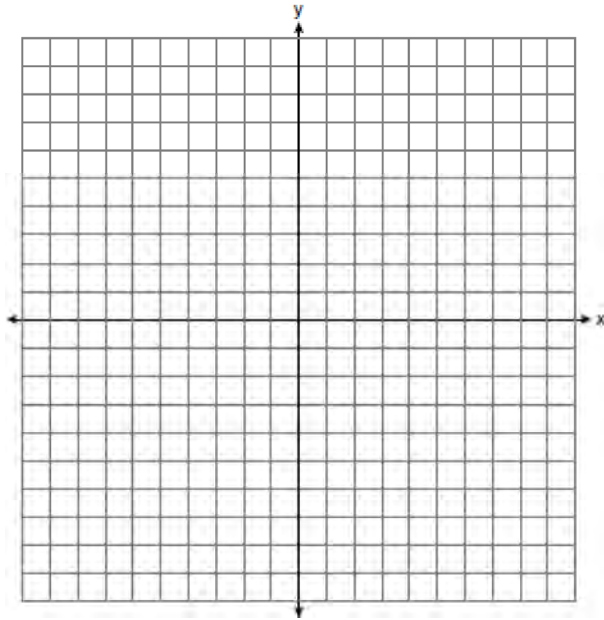

- 106 In the diagram of $\triangle ABC$ below, $AB = 10$, $BC = 14$, and $AC = 16$. Find the perimeter of the triangle formed by connecting the midpoints of the sides of $\triangle ABC$.

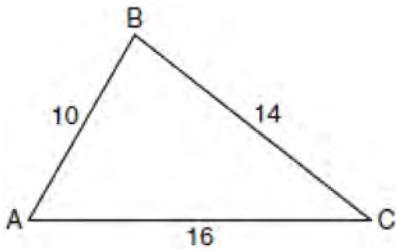

- 107 In the diagram below, tangent \overline{PA} and secant \overline{PBC} are drawn to circle O from external point P .

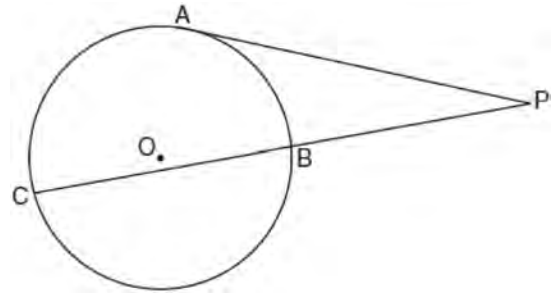

- If $PB = 4$ and $BC = 5$, what is the length of \overline{PA} ?
- 1) 20
 - 2) 9
 - 3) 8
 - 4) 6

- 108 In a coordinate plane, how many points are both 5 units from the origin and 2 units from the x -axis?
- 1) 1
 - 2) 2
 - 3) 3
 - 4) 4

- 109 The equation of line k is $y = \frac{1}{3}x - 2$. The equation of line m is $-2x + 6y = 18$. Lines k and m are
- 1) parallel
 - 2) perpendicular
 - 3) the same line
 - 4) neither parallel nor perpendicular

- 110 Using a compass and straightedge, on the diagram below of \overleftrightarrow{RS} , construct an equilateral triangle with \overline{RS} as one side. [Leave all construction marks.]



- 111 Which transformation is *not* always an isometry?
 1) rotation
 2) dilation
 3) reflection
 4) translation

- 112 In rhombus $ABCD$, the diagonals \overline{AC} and \overline{BD} intersect at E . If $AE = 5$ and $BE = 12$, what is the length of \overline{AB} ?
 1) 7
 2) 10
 3) 13
 4) 17

- 113 Which expression represents the volume, in cubic centimeters, of the cylinder represented in the diagram below?

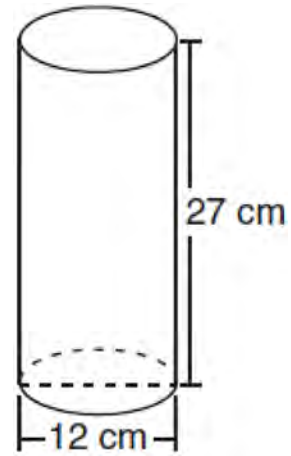

- 1) 162π
 2) 324π
 3) 972π
 4) $3,888\pi$

- 114 The pentagon in the diagram below is formed by five rays.

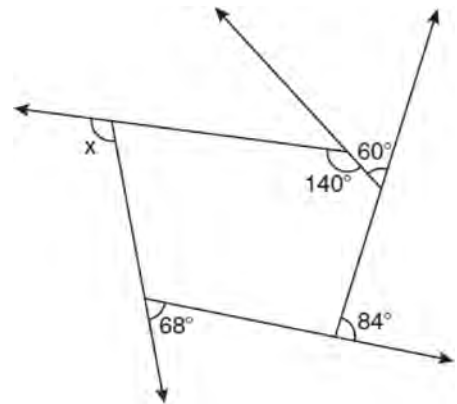

What is the degree measure of angle x ?

- 1) 72
 2) 96
 3) 108
 4) 112

- 115 In the diagram of quadrilateral $ABCD$, $\overline{AB} \parallel \overline{CD}$, $\angle ABC \cong \angle CDA$, and diagonal \overline{AC} is drawn.

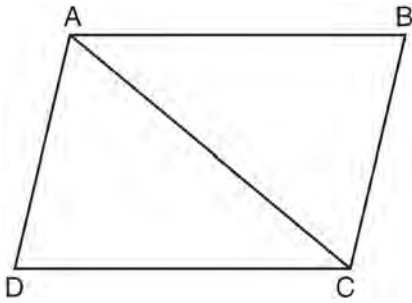

Which method can be used to prove $\triangle ABC$ is congruent to $\triangle CDA$?

- 1) AAS
 - 2) SSA
 - 3) SAS
 - 4) SSS
- 116 In the diagram below, tangent \overline{ML} and secant \overline{MNK} are drawn to circle O . The ratio $m\widehat{LN} : m\widehat{NK} : m\widehat{KL}$ is 3:4:5. Find $m\angle LMK$.

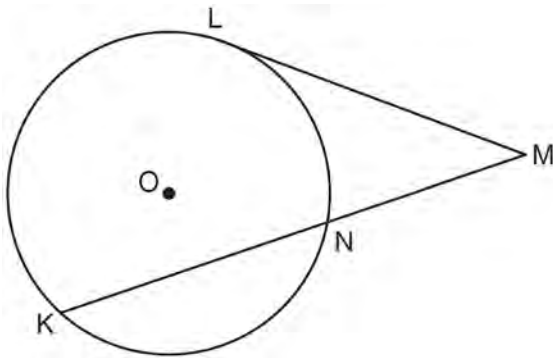

- 117 When writing a geometric proof, which angle relationship could be used alone to justify that two angles are congruent?
- 1) supplementary angles
 - 2) linear pair of angles
 - 3) adjacent angles
 - 4) vertical angles

- 118 In the diagram below, \overline{BFCE} , $\overline{AB} \perp \overline{BE}$, $\overline{DE} \perp \overline{BE}$, and $\angle BFD \cong \angle ECA$. Prove that $\triangle ABC \sim \triangle DEF$.

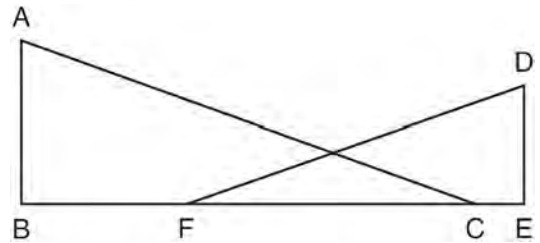

- 119 What is the converse of the statement "If Bob does his homework, then George gets candy"?
- 1) If George gets candy, then Bob does his homework.
 - 2) Bob does his homework if and only if George gets candy.
 - 3) If George does not get candy, then Bob does not do his homework.
 - 4) If Bob does not do his homework, then George does not get candy.

120 Square $LMNO$ is shown in the diagram below.

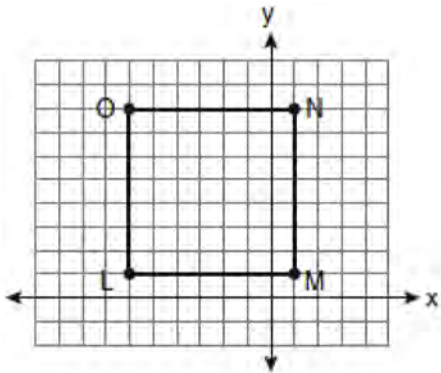

What are the coordinates of the midpoint of diagonal \overline{LN} ?

- 1) $\left(4\frac{1}{2}, -2\frac{1}{2}\right)$
- 2) $\left(-3\frac{1}{2}, 3\frac{1}{2}\right)$
- 3) $\left(-2\frac{1}{2}, 3\frac{1}{2}\right)$
- 4) $\left(-2\frac{1}{2}, 4\frac{1}{2}\right)$

121 In the diagram below, circles X and Y have two tangents drawn to them from external point T . The points of tangency are $C, A, S,$ and E . The ratio of \overline{TA} to \overline{AC} is $1:3$. If $\overline{TS} = 24$, find the length of \overline{SE} .

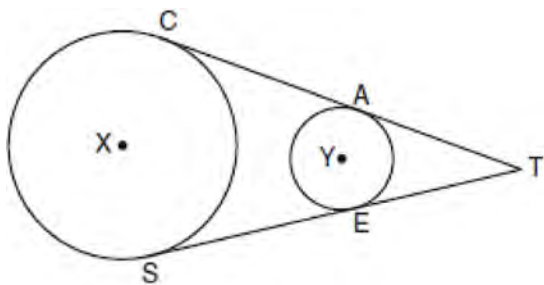

(Not drawn to scale)

122 In the diagram below of circle O , \overline{PA} is tangent to circle O at A , and \overline{PBC} is a secant with points B and C on the circle.

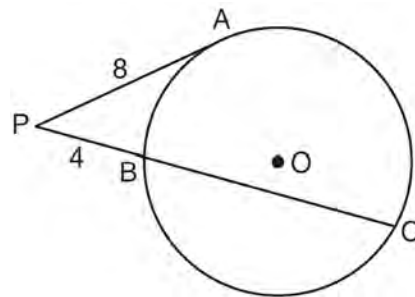

If $PA = 8$ and $PB = 4$, what is the length of \overline{BC} ?

- 1) 20
- 2) 16
- 3) 15
- 4) 12

123 In the diagram of $\triangle ABC$ and $\triangle DEF$ below, $\overline{AB} \cong \overline{DE}$, $\angle A \cong \angle D$, and $\angle B \cong \angle E$.

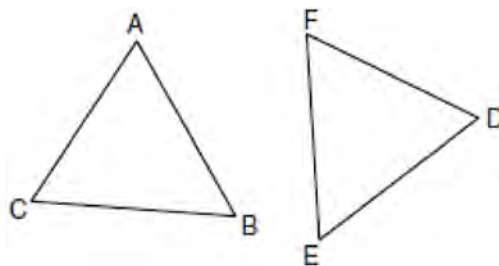

Which method can be used to prove $\triangle ABC \cong \triangle DEF$?

- 1) SSS
- 2) SAS
- 3) ASA
- 4) HL

124 What is an equation of the line that passes through the point $(-2,5)$ and is perpendicular to the line whose equation is $y = \frac{1}{2}x + 5$?

- 1) $y = 2x + 1$
- 2) $y = -2x + 1$
- 3) $y = 2x + 9$
- 4) $y = -2x - 9$

125 In circle O , diameter \overline{RS} has endpoints $R(3a, 2b - 1)$ and $S(a - 6, 4b + 5)$. Find the coordinates of point O , in terms of a and b . Express your answer in simplest form.

126 Based on the construction below, which statement must be true?

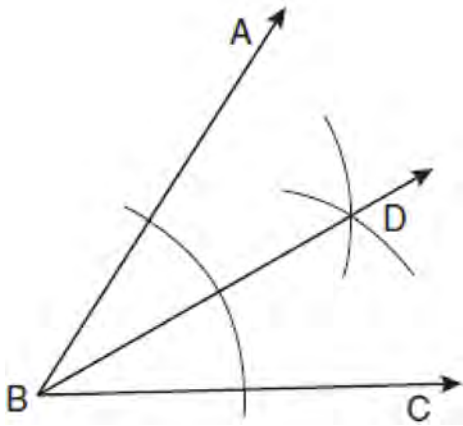

- 1) $m\angle ABD = \frac{1}{2} m\angle CBD$
- 2) $m\angle ABD = m\angle CBD$
- 3) $m\angle ABD = m\angle ABC$
- 4) $m\angle CBD = \frac{1}{2} m\angle ABD$

127 As shown in the diagram below, $\triangle ABC \sim \triangle DEF$, $AB = 7x$, $BC = 4$, $DE = 7$, and $EF = x$.

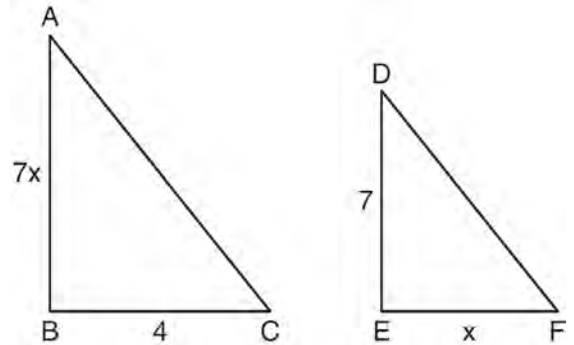

What is the length of \overline{AB} ?

- 1) 28
- 2) 2
- 3) 14
- 4) 4

128 Lines j and k intersect at point P . Line m is drawn so that it is perpendicular to lines j and k at point P . Which statement is correct?

- 1) Lines j and k are in perpendicular planes.
- 2) Line m is in the same plane as lines j and k .
- 3) Line m is parallel to the plane containing lines j and k .
- 4) Line m is perpendicular to the plane containing lines j and k .

129 What are the center and the radius of the circle whose equation is $(x - 5)^2 + (y + 3)^2 = 16$?

- 1) $(-5, 3)$ and 16
- 2) $(5, -3)$ and 16
- 3) $(-5, 3)$ and 4
- 4) $(5, -3)$ and 4

- 130 In the diagram below, \overline{AB} , \overline{BC} , and \overline{AC} are tangents to circle O at points F , E , and D , respectively, $AF = 6$, $CD = 5$, and $BE = 4$.

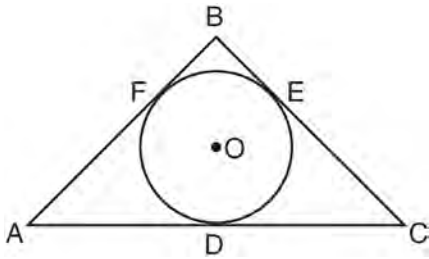

What is the perimeter of $\triangle ABC$?

- 1) 15
 - 2) 25
 - 3) 30
 - 4) 60
- 131 In the diagram below of $\triangle ADE$, B is a point on \overline{AE} and C is a point on \overline{AD} such that $\overline{BC} \parallel \overline{ED}$, $AC = x - 3$, $BE = 20$, $AB = 16$, and $AD = 2x + 2$. Find the length of AC .

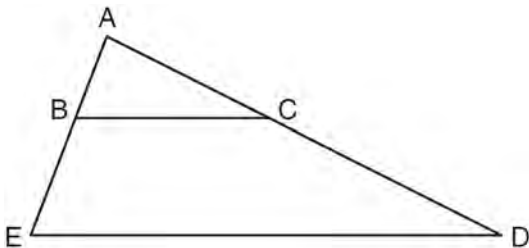

- 132 Side \overline{PQ} of $\triangle PQR$ is extended through Q to point T . Which statement is *not* always true?
- 1) $m\angle RQT > m\angle R$
 - 2) $m\angle RQT > m\angle P$
 - 3) $m\angle RQT = m\angle P + m\angle R$
 - 4) $m\angle RQT > m\angle PQR$

- 133 What is an equation of a circle with center $(7, -3)$ and radius 4?
- 1) $(x - 7)^2 + (y + 3)^2 = 4$
 - 2) $(x + 7)^2 + (y - 3)^2 = 4$
 - 3) $(x - 7)^2 + (y + 3)^2 = 16$
 - 4) $(x + 7)^2 + (y - 3)^2 = 16$

- 134 The diagram below shows a right pentagonal prism.

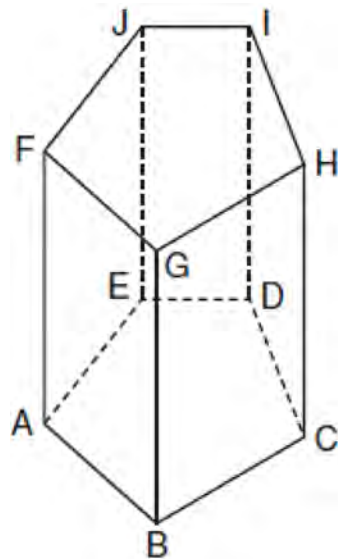

Which statement is always true?

- 1) $\overline{BC} \parallel \overline{ED}$
- 2) $\overline{FG} \parallel \overline{CD}$
- 3) $\overline{FJ} \parallel \overline{IH}$
- 4) $\overline{GB} \parallel \overline{HC}$

- 135 Which line is parallel to the line whose equation is $4x + 3y = 7$ and also passes through the point $(-5, 2)$?
- 1) $4x + 3y = -26$
 - 2) $4x + 3y = -14$
 - 3) $3x + 4y = -7$
 - 4) $3x + 4y = 14$

- 136 Given: Quadrilateral $ABCD$ with $\overline{AB} \cong \overline{CD}$, $\overline{AD} \cong \overline{BC}$, and diagonal \overline{BD} is drawn
Prove: $\angle BDC \cong \angle ABD$

- 137 In the diagram below of circle O , chord \overline{AB} bisects chord \overline{CD} at E . If $AE = 8$ and $BE = 9$, find the length of \overline{CE} in simplest radical form.

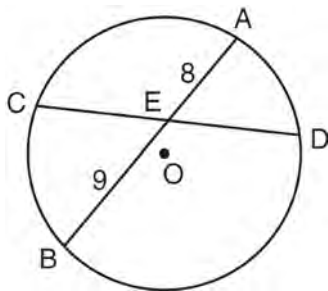

- 138 What is an equation of a circle with its center at $(-3, 5)$ and a radius of 4?
- 1) $(x - 3)^2 + (y + 5)^2 = 16$
 - 2) $(x + 3)^2 + (y - 5)^2 = 16$
 - 3) $(x - 3)^2 + (y + 5)^2 = 4$
 - 4) $(x + 3)^2 + (y - 5)^2 = 4$

- 139 In the diagram below of circle C , \overline{QR} is a diameter, and $Q(1, 8)$ and $C(3.5, 2)$ are points on a coordinate plane. Find and state the coordinates of point R .

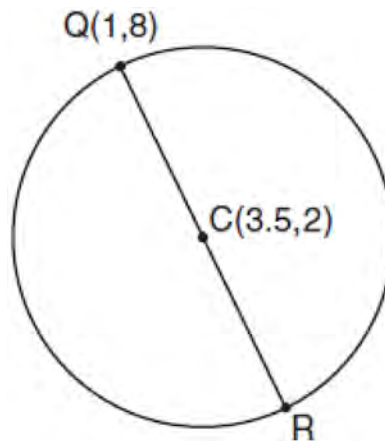

- 140 In the diagram below of $\triangle ACD$, E is a point on \overline{AD} and B is a point on \overline{AC} , such that $\overline{EB} \parallel \overline{DC}$. If $\overline{AE} = 3$, $\overline{ED} = 6$, and $\overline{DC} = 15$, find the length of \overline{EB} .

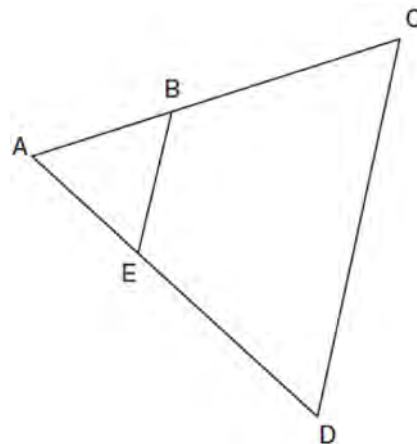

- 141 In the diagram below, the length of the legs \overline{AC} and \overline{BC} of right triangle ABC are 6 cm and 8 cm, respectively. Altitude \overline{CD} is drawn to the hypotenuse of $\triangle ABC$.

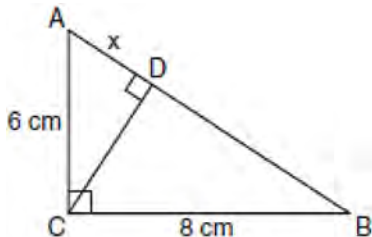

What is the length of \overline{AD} to the nearest tenth of a centimeter?

- 1) 3.6
 - 2) 6.0
 - 3) 6.4
 - 4) 4.0
- 142 A man wants to place a new bird bath in his yard so that it is 30 feet from a fence, f , and also 10 feet from a light pole, P . As shown in the diagram below, the light pole is 35 feet away from the fence.

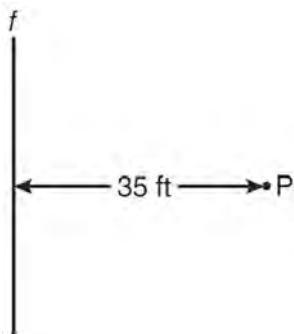

How many locations are possible for the bird bath?

- 1) 1
- 2) 2
- 3) 3
- 4) 0

- 143 In three-dimensional space, two planes are parallel and a third plane intersects both of the parallel planes. The intersection of the planes is a
- 1) plane
 - 2) point
 - 3) pair of parallel lines
 - 4) pair of intersecting lines

- 144 Which expression best describes the transformation shown in the diagram below?

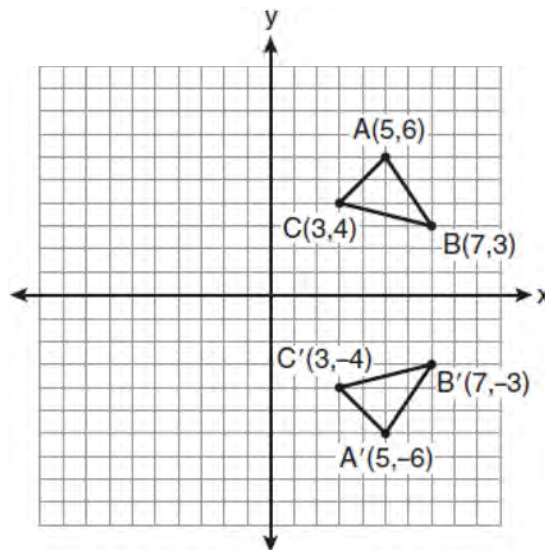

- 1) same orientation; reflection
- 2) opposite orientation; reflection
- 3) same orientation; translation
- 4) opposite orientation; translation

- 145 Find the slope of a line perpendicular to the line whose equation is $2y - 6x = 4$.

- 146 In the diagram below of $\triangle ABC$, D is a point on \overline{AB} , E is a point on \overline{BC} , $\overline{AC} \parallel \overline{DE}$, $CE = 25$ inches, $AD = 18$ inches, and $DB = 12$ inches. Find, to the nearest tenth of an inch, the length of \overline{EB} .

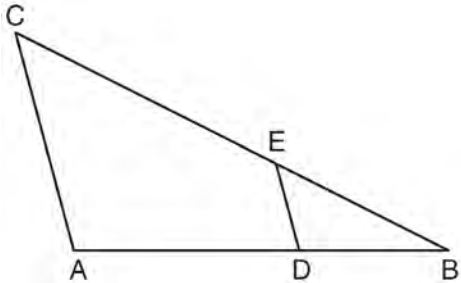

- 147 In the diagram below of circle O , chord \overline{AB} is parallel to chord \overline{CD} .

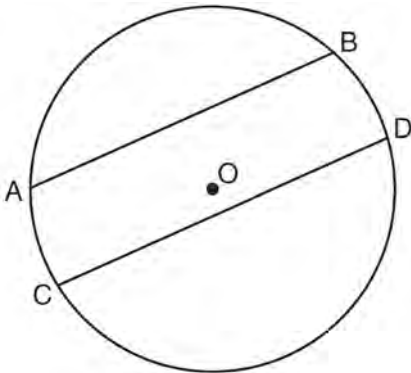

Which statement must be true?

- 1) $\overline{AC} \cong \overline{BD}$
- 2) $\overline{AB} \cong \overline{CD}$
- 3) $\overline{AB} \cong \overline{CD}$
- 4) $\overline{ABD} \cong \overline{CDB}$

- 148 In the diagram below of circle O , chords \overline{AD} and \overline{BC} intersect at E , $m\widehat{AC} = 87$, and $m\widehat{BD} = 35$.

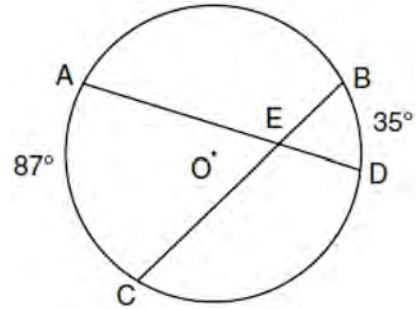

What is the degree measure of $\angle CEA$?

- 1) 87
- 2) 61
- 3) 43.5
- 4) 26

- 149 Given: Two is an even integer or three is an even integer.
Determine the truth value of this disjunction.
Justify your answer.

- 150 In scalene triangle ABC , $m\angle B = 45$ and $m\angle C = 55$.
What is the order of the sides in length, from longest to shortest?

- 1) $\overline{AB}, \overline{BC}, \overline{AC}$
- 2) $\overline{BC}, \overline{AC}, \overline{AB}$
- 3) $\overline{AC}, \overline{BC}, \overline{AB}$
- 4) $\overline{BC}, \overline{AB}, \overline{AC}$

- 151 In the diagram below of $\triangle ACD$, B is a point on \overline{AC} such that $\triangle ADB$ is an equilateral triangle, and $\triangle DBC$ is an isosceles triangle with $DB \cong BC$. Find $m\angle C$.

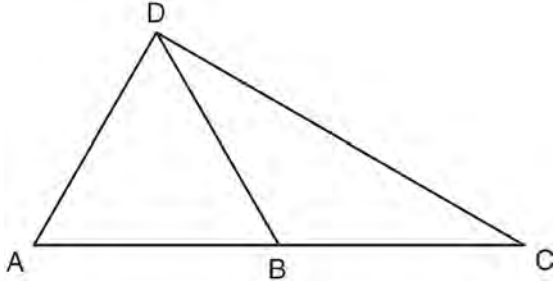

- 152 In the diagram below, under which transformation will $\triangle A'B'C'$ be the image of $\triangle ABC$?

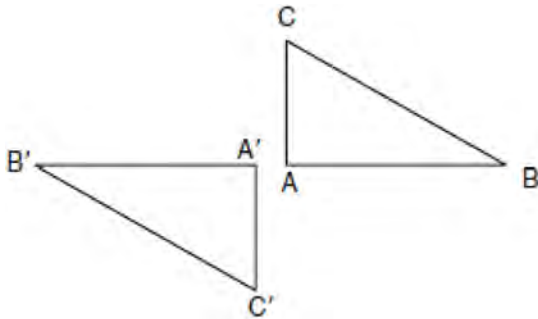

- 1) rotation
 - 2) dilation
 - 3) translation
 - 4) glide reflection
- 153 Which transformation can map the letter **S** onto itself?
- 1) glide reflection
 - 2) translation
 - 3) line reflection
 - 4) rotation

- 154 Given $\triangle ABC \sim \triangle DEF$ such that $\frac{AB}{DE} = \frac{3}{2}$. Which statement is *not* true?

- 1) $\frac{BC}{EF} = \frac{3}{2}$
- 2) $\frac{m\angle A}{m\angle D} = \frac{3}{2}$
- 3) $\frac{\text{area of } \triangle ABC}{\text{area of } \triangle DEF} = \frac{9}{4}$
- 4) $\frac{\text{perimeter of } \triangle ABC}{\text{perimeter of } \triangle DEF} = \frac{3}{2}$

- 155 If the vertex angles of two isosceles triangles are congruent, then the triangles must be

- 1) acute
- 2) congruent
- 3) right
- 4) similar

- 156 On the diagram below, use a compass and straightedge to construct the bisector of $\angle ABC$. [Leave all construction marks.]

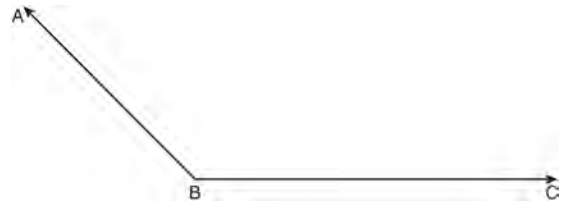

157 Which illustration shows the correct construction of an angle bisector?

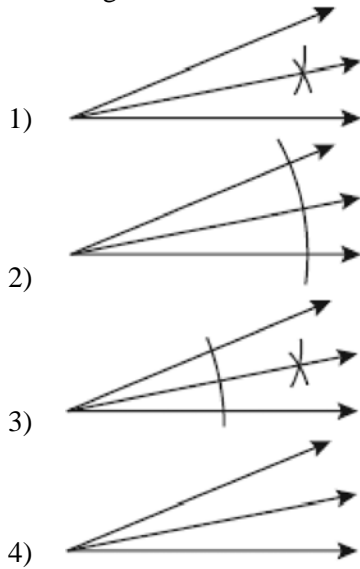

158 In the diagram below of trapezoid $RSUT$, $\overline{RS} \parallel \overline{TU}$, X is the midpoint of \overline{RT} , and V is the midpoint of \overline{SU} .

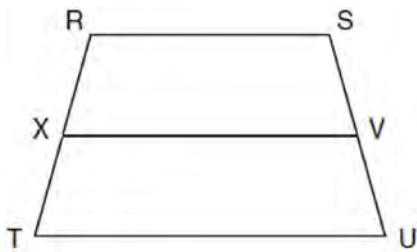

If $RS = 30$ and $XV = 44$, what is the length of \overline{TU} ?

- 1) 37
- 2) 58
- 3) 74
- 4) 118

159 Triangle XYZ , shown in the diagram below, is reflected over the line $x = 2$. State the coordinates of $\triangle X'Y'Z'$, the image of $\triangle XYZ$.

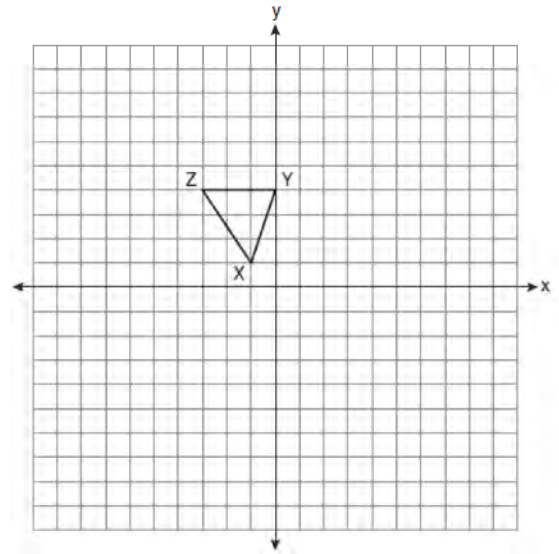

160 In the diagram of $\triangle ABC$ and $\triangle EDC$ below, \overline{AE} and \overline{BD} intersect at C , and $\angle CAB \cong \angle CED$.

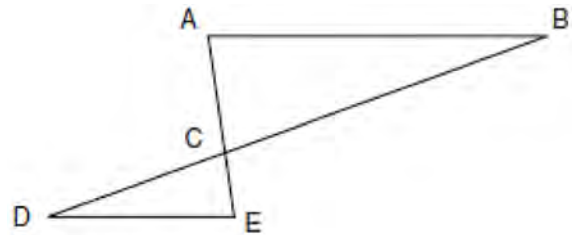

Which method can be used to show that $\triangle ABC$ must be similar to $\triangle EDC$?

- 1) SAS
- 2) AA
- 3) SSS
- 4) HL

- 161 The lateral faces of a regular pyramid are composed of
- 1) squares
 - 2) rectangles
 - 3) congruent right triangles
 - 4) congruent isosceles triangles

- 162 Triangle ABC has vertices $A(0,0)$, $B(3,2)$, and $C(0,4)$. The triangle may be classified as
- 1) equilateral
 - 2) isosceles
 - 3) right
 - 4) scalene

- 163 What is the inverse of the statement “If two triangles are not similar, their corresponding angles are not congruent”?
- 1) If two triangles are similar, their corresponding angles are not congruent.
 - 2) If corresponding angles of two triangles are not congruent, the triangles are not similar.
 - 3) If two triangles are similar, their corresponding angles are congruent.
 - 4) If corresponding angles of two triangles are congruent, the triangles are similar.

- 164 Which compound statement is true?
- 1) A triangle has three sides and a quadrilateral has five sides.
 - 2) A triangle has three sides if and only if a quadrilateral has five sides.
 - 3) If a triangle has three sides, then a quadrilateral has five sides.
 - 4) A triangle has three sides or a quadrilateral has five sides.

- 165 In the diagram below of circle O , chords \overline{AE} and \overline{DC} intersect at point B , such that $m\widehat{AC} = 36$ and $m\widehat{DE} = 20$.

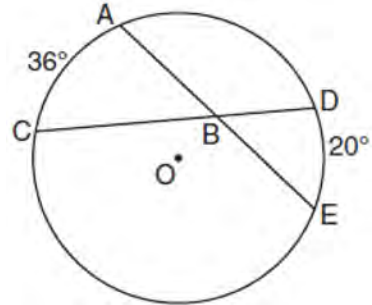

What is $m\angle ABC$?

- 1) 56
 - 2) 36
 - 3) 28
 - 4) 8
- 166 In the diagram below of circle O , chords \overline{AD} and \overline{BC} intersect at E .

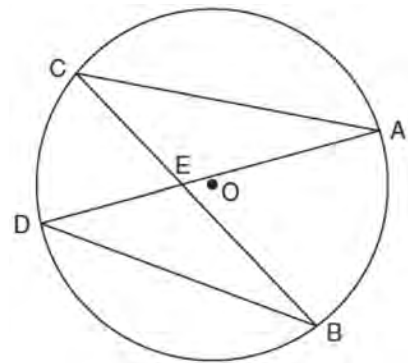

Which relationship must be true?

- 1) $\triangle CAE \cong \triangle DBE$
- 2) $\triangle AEC \sim \triangle BED$
- 3) $\angle ACB \cong \angle CBD$
- 4) $\widehat{CA} \cong \widehat{DB}$

- 167 Quadrilateral $MATH$ has coordinates $M(1,1)$, $A(-2,5)$, $T(3,5)$, and $H(6,1)$. Prove that quadrilateral $MATH$ is a rhombus and prove that it is *not* a square. [The use of the grid is optional.]

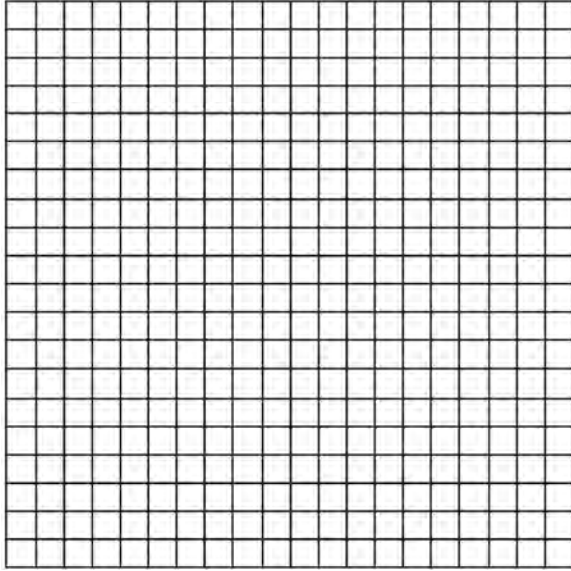

- 168 In the diagram below, line p intersects line m and line n .

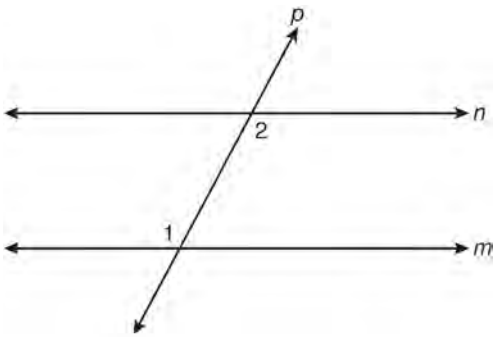

If $m\angle 1 = 7x$ and $m\angle 2 = 5x + 30$, lines m and n are parallel when x equals

- 1) 12.5
- 2) 15
- 3) 87.5
- 4) 105

- 169 Which diagram shows the construction of an equilateral triangle?

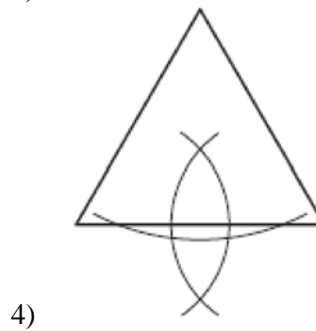
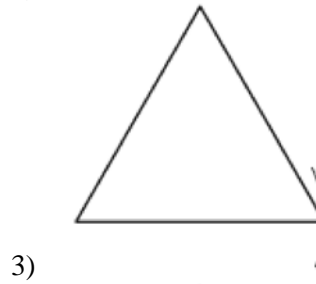
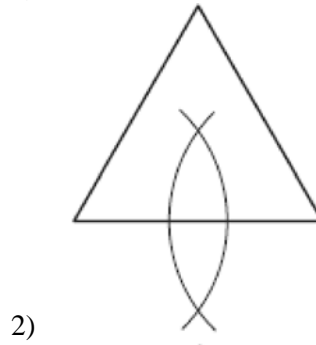
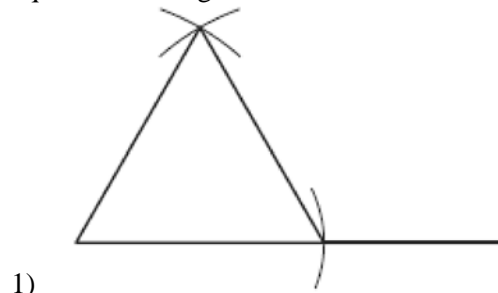

170 Which diagram shows the construction of the perpendicular bisector of \overline{AB} ?

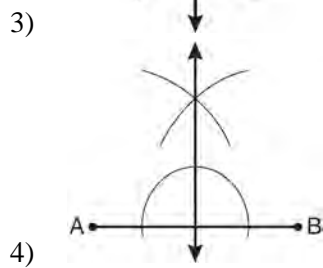
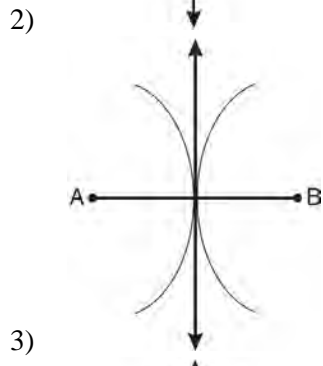
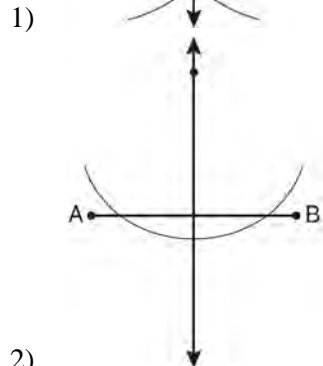
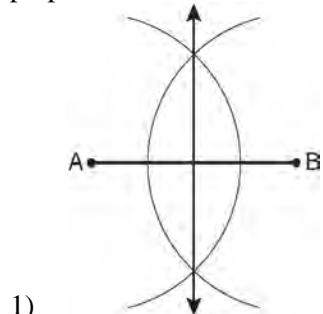

171 In the diagram below of $\triangle ADB$, $m\angle BDA = 90^\circ$, $AD = 5\sqrt{2}$, and $AB = 2\sqrt{15}$.

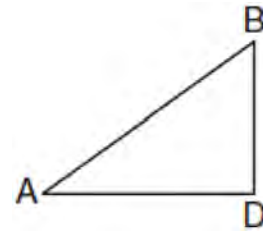

What is the length of \overline{BD} ?

- 1) $\sqrt{10}$
- 2) $\sqrt{20}$
- 3) $\sqrt{50}$
- 4) $\sqrt{110}$

172 On the set of axes below, graph the locus of points that are four units from the point $(2, 1)$. On the same set of axes, graph the locus of points that are two units from the line $x = 4$. State the coordinates of all points that satisfy both conditions.

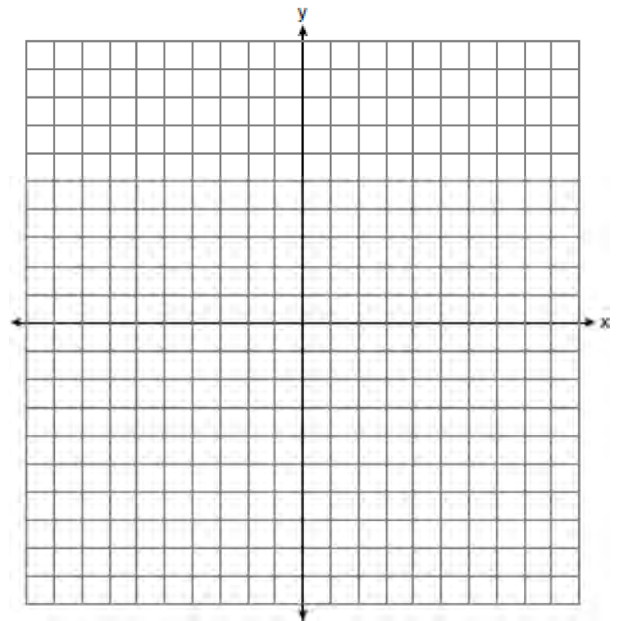

173 Line segment AB is shown in the diagram below.

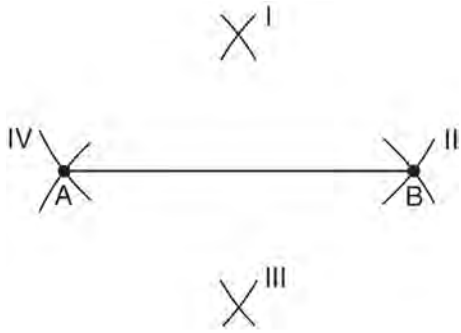

Which two sets of construction marks, labeled I, II, III, and IV, are part of the construction of the perpendicular bisector of line segment AB ?

- 1) I and II
- 2) I and III
- 3) II and III
- 4) II and IV

174 The diagram below shows a rectangular prism.

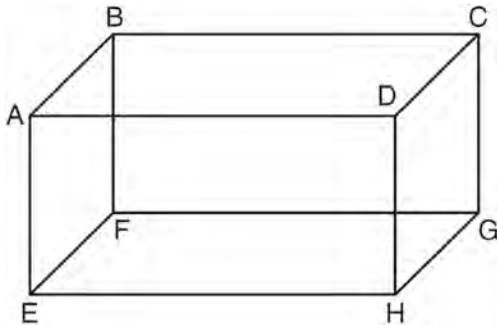

Which pair of edges are segments of lines that are coplanar?

- 1) \overline{AB} and \overline{DH}
- 2) \overline{AE} and \overline{DC}
- 3) \overline{BC} and \overline{EH}
- 4) \overline{CG} and \overline{EF}

175 A circle is represented by the equation $x^2 + (y + 3)^2 = 13$. What are the coordinates of the center of the circle and the length of the radius?

- 1) $(0, 3)$ and 13
- 2) $(0, 3)$ and $\sqrt{13}$
- 3) $(0, -3)$ and 13
- 4) $(0, -3)$ and $\sqrt{13}$

176 In the diagram below, $\triangle A'B'C'$ is a transformation of $\triangle ABC$, and $\triangle A''B''C''$ is a transformation of $\triangle A'B'C'$.

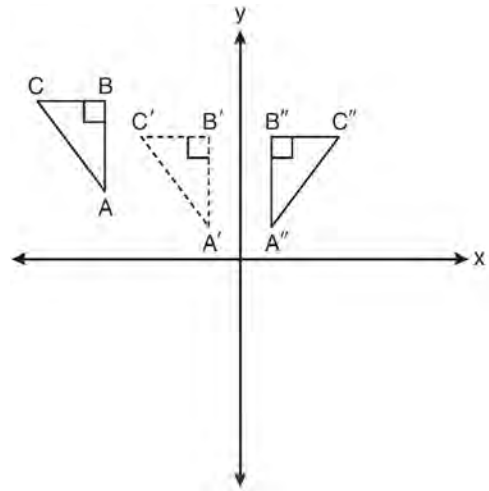

The composite transformation of $\triangle ABC$ to $\triangle A''B''C''$ is an example of a

- 1) reflection followed by a rotation
- 2) reflection followed by a translation
- 3) translation followed by a rotation
- 4) translation followed by a reflection

- 177 In the diagram below, $\triangle ABC$ is inscribed in circle P . The distances from the center of circle P to each side of the triangle are shown.

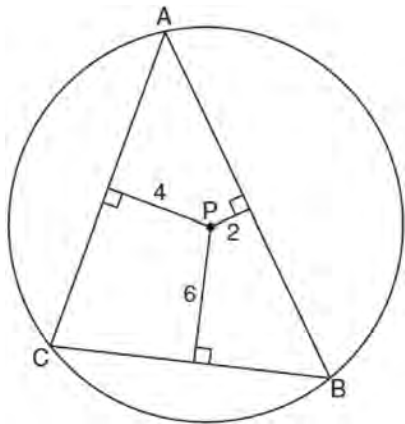

Which statement about the sides of the triangle is true?

- 1) $AB > AC > BC$
 - 2) $AB < AC$ and $AC > BC$
 - 3) $AC > AB > BC$
 - 4) $AC = AB$ and $AB > BC$
- 178 Quadrilateral $MNOP$ is a trapezoid with $\overline{MN} \parallel \overline{OP}$.

If $M'N'O'P'$ is the image of $MNOP$ after a reflection over the x -axis, which two sides of quadrilateral $M'N'O'P'$ are parallel?

- 1) $\overline{M'N'}$ and $\overline{O'P'}$
- 2) $\overline{M'N'}$ and $\overline{N'O'}$
- 3) $\overline{P'M'}$ and $\overline{O'P'}$
- 4) $\overline{P'M'}$ and $\overline{N'O'}$

- 179 In the diagram below of right triangle ABC , \overline{CD} is the altitude to hypotenuse \overline{AB} , $CB = 6$, and $AD = 5$.

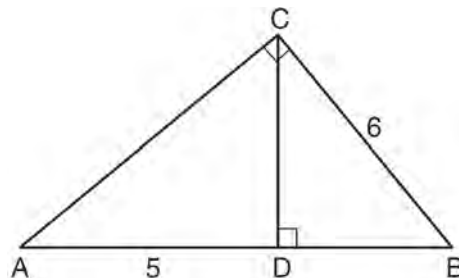

What is the length of \overline{BD} ?

- 1) 5
 - 2) 9
 - 3) 3
 - 4) 4
- 180 In $\triangle KLM$, $m\angle K = 36$ and $KM = 5$. The transformation D_2 is performed on $\triangle KLM$ to form $\triangle K'L'M'$. Find $m\angle K'$. Justify your answer. Find the length of $\overline{K'M'}$. Justify your answer.

- 181 Which equation represents a line perpendicular to the line whose equation is $2x + 3y = 12$?
- 1) $6y = -4x + 12$
 - 2) $2y = 3x + 6$
 - 3) $2y = -3x + 6$
 - 4) $3y = -2x + 12$

- 182 In an equilateral triangle, what is the difference between the sum of the exterior angles and the sum of the interior angles?
- 1) 180°
 - 2) 120°
 - 3) 90°
 - 4) 60°

183 Which graph represents a circle with the equation $(x - 3)^2 + (y + 1)^2 = 4$?

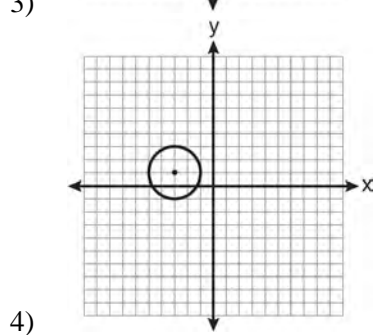
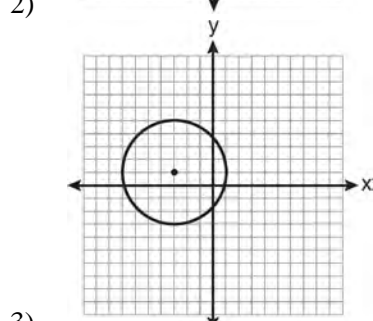
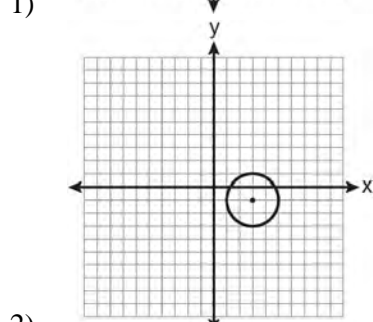
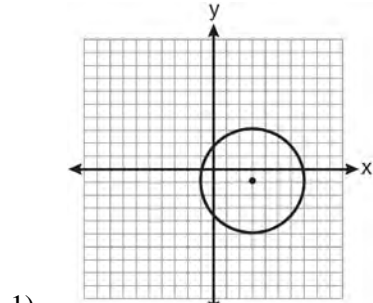

184 In the diagram below, tangent \overline{AB} and secant \overline{ACD} are drawn to circle O from an external point A , $AB = 8$, and $AC = 4$.

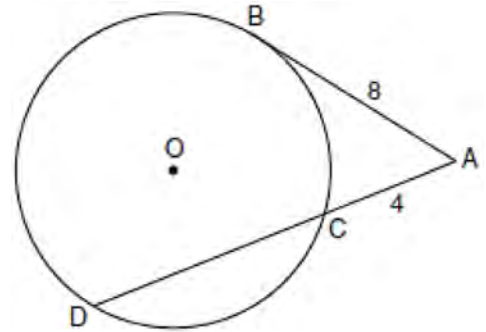

What is the length of \overline{CD} ?

- 1) 16
- 2) 13
- 3) 12
- 4) 10

185 What is the slope of a line that is perpendicular to the line whose equation is $3x + 5y = 4$?

- 1) $-\frac{3}{5}$
- 2) $\frac{3}{5}$
- 3) $-\frac{5}{3}$
- 4) $\frac{5}{3}$

Geometry Regents Exam Questions at Random

www.jmap.org

- 186 The two lines represented by the equations below are graphed on a coordinate plane.

$$x + 6y = 12$$

$$3(x - 2) = -y - 4$$

Which statement best describes the two lines?

- 1) The lines are parallel.
- 2) The lines are the same line.
- 3) The lines are perpendicular.
- 4) The lines intersect at an angle other than 90° .

- 187 Line segment \overline{AB} is tangent to circle O at A . Which type of triangle is always formed when points A , B , and O are connected?

- 1) right
- 2) obtuse
- 3) scalene
- 4) isosceles

- 190 The length of \overline{AB} is 3 inches. On the diagram below, sketch the points that are equidistant from A and B and sketch the points that are 2 inches from A . Label with an **X** all points that satisfy both conditions.



- 188 In the diagram below, parallelogram $ABCD$ has diagonals \overline{AC} and \overline{BD} that intersect at point E .

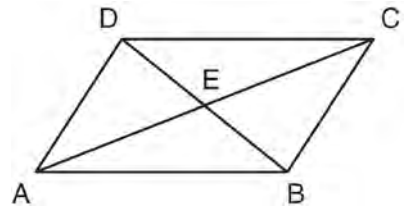

Which expression is *not* always true?

- 1) $\angle DAE \cong \angle BCE$
- 2) $\angle DEC \cong \angle BEA$
- 3) $\overline{AC} \cong \overline{DB}$
- 4) $\overline{DE} \cong \overline{EB}$

- 189 What is the contrapositive of the statement, "If I am tall, then I will bump my head"?

- 1) If I bump my head, then I am tall.
- 2) If I do not bump my head, then I am tall.
- 3) If I am tall, then I will not bump my head.
- 4) If I do not bump my head, then I am not tall.

Geometry Regents at Random

- 191 In the diagram below of $\triangle ABC$, D is a point on \overline{AB} , $AC = 7$, $AD = 6$, and $BC = 18$.

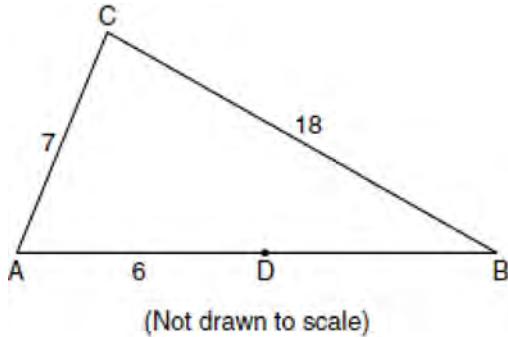

- The length of \overline{DB} could be
- 1) 5
 - 2) 12
 - 3) 19
 - 4) 25
- 192 The degree measures of the angles of $\triangle ABC$ are represented by x , $3x$, and $5x - 54$. Find the value of x .
- 193 In which polygon does the sum of the measures of the interior angles equal the sum of the measures of the exterior angles?
- 1) triangle
 - 2) hexagon
 - 3) octagon
 - 4) quadrilateral

- 194 Which geometric principle is used in the construction shown below?

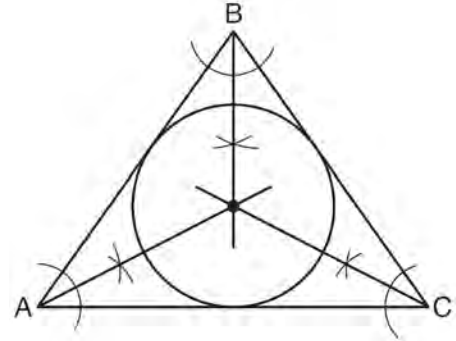

- 1) The intersection of the angle bisectors of a triangle is the center of the inscribed circle.
 - 2) The intersection of the angle bisectors of a triangle is the center of the circumscribed circle.
 - 3) The intersection of the perpendicular bisectors of the sides of a triangle is the center of the inscribed circle.
 - 4) The intersection of the perpendicular bisectors of the sides of a triangle is the center of the circumscribed circle.
- 195 Given the equations: $y = x^2 - 6x + 10$
 $y + x = 4$
- What is the solution to the given system of equations?
- 1) (2,3)
 - 2) (3,2)
 - 3) (2,2) and (1,3)
 - 4) (2,2) and (3,1)

- 196 In the diagram below, $\triangle RST$ is a 3-4-5 right triangle. The altitude, h , to the hypotenuse has been drawn. Determine the length of h .

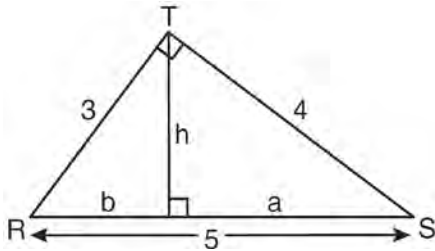

- 197 Which equation represents the line parallel to the line whose equation is $4x + 2y = 14$ and passing through the point $(2, 2)$?

- 1) $y = -2x$
- 2) $y = -2x + 6$
- 3) $y = \frac{1}{2}x$
- 4) $y = \frac{1}{2}x + 1$

- 198 What is the length of the line segment whose endpoints are $(1, -4)$ and $(9, 2)$?

- 1) 5
- 2) $2\sqrt{17}$
- 3) 10
- 4) $2\sqrt{26}$

- 199 In the diagram below of $\triangle HQP$, side \overline{HP} is extended through P to T , $m\angle QPT = 6x + 20$, $m\angle HQP = x + 40$, and $m\angle PHQ = 4x - 5$. Find $m\angle QPT$.

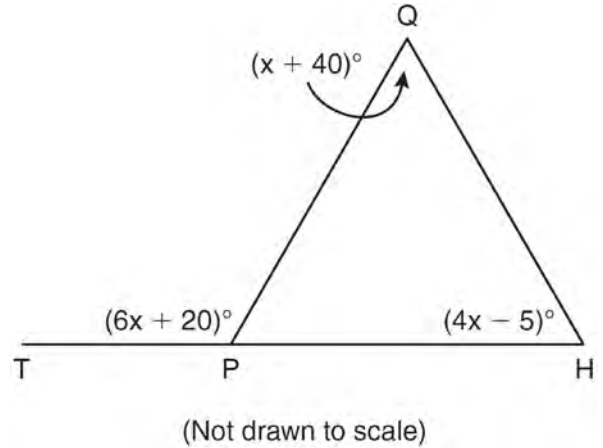

- 200 A sphere has a diameter of 18 meters. Find the volume of the sphere, in cubic meters, in terms of π .

- 201 In the diagram below, trapezoid $ABCD$, with bases \overline{AB} and \overline{DC} , is inscribed in circle O , with diameter \overline{DC} . If $m\widehat{AB} = 80$, find $m\widehat{BC}$.

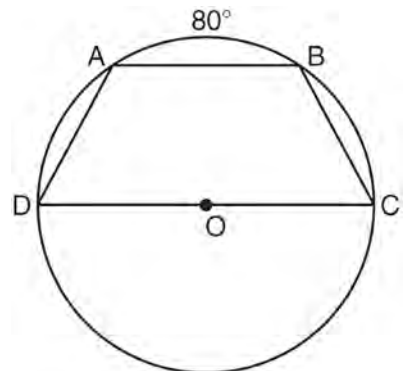

Geometry Regents Exam Questions at Random

www.jmap.org

- 202 Triangle ABC has vertices $A(1,3)$, $B(0,1)$, and $C(4,0)$. Under a translation, A' , the image point of A , is located at $(4,4)$. Under this same translation, point C' is located at
- 1) $(7,1)$
 - 2) $(5,3)$
 - 3) $(3,2)$
 - 4) $(1,-1)$

- 203 Segment AB is the diameter of circle M . The coordinates of A are $(-4,3)$. The coordinates of M are $(1,5)$. What are the coordinates of B ?
- 1) $(6,7)$
 - 2) $(5,8)$
 - 3) $(-3,8)$
 - 4) $(-5,2)$

- 204 In the diagram below, $\triangle ABC \cong \triangle XYZ$.

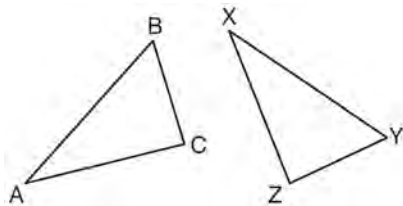

Which two statements identify corresponding congruent parts for these triangles?

- 1) $\overline{AB} \cong \overline{XY}$ and $\angle C \cong \angle Y$
- 2) $\overline{AB} \cong \overline{YZ}$ and $\angle C \cong \angle X$
- 3) $\overline{BC} \cong \overline{XY}$ and $\angle A \cong \angle Y$
- 4) $\overline{BC} \cong \overline{YZ}$ and $\angle A \cong \angle X$

- 205 If two different lines are perpendicular to the same plane, they are
- 1) collinear
 - 2) coplanar
 - 3) congruent
 - 4) consecutive

- 206 Write a statement that is logically equivalent to the statement “If two sides of a triangle are congruent, the angles opposite those sides are congruent.” Identify the new statement as the converse, inverse, or contrapositive of the original statement.

- 207 Tangents \overline{PA} and \overline{PB} are drawn to circle O from an external point, P , and radii \overline{OA} and \overline{OB} are drawn. If $m\angle APB = 40$, what is the measure of $\angle AOB$?
- 1) 140°
 - 2) 100°
 - 3) 70°
 - 4) 50°

- 208 Isosceles trapezoid $ABCD$ has diagonals \overline{AC} and \overline{BD} . If $AC = 5x + 13$ and $BD = 11x - 5$, what is the value of x ?
- 1) 28
 - 2) $10\frac{3}{4}$
 - 3) 3
 - 4) $\frac{1}{2}$

Geometry Regents Exam Questions at Random

www.jmap.org

209 A right circular cone has a base with a radius of 15 cm, a vertical height of 20 cm, and a slant height of 25 cm. Find, in terms of π , the number of square centimeters in the lateral area of the cone.

210 The lines represented by the equations $y + \frac{1}{2}x = 4$

and $3x + 6y = 12$ are

- 1) the same line
- 2) parallel
- 3) perpendicular
- 4) neither parallel nor perpendicular

211 In the diagram below, \overline{PS} is a tangent to circle O at point S , \overline{PQR} is a secant, $PS = x$, $PQ = 3$, and $PR = x + 18$.

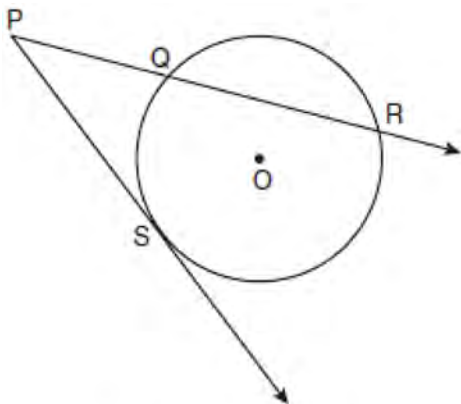

(Not drawn to scale)

What is the length of \overline{PS} ?

- 1) 6
- 2) 9
- 3) 3
- 4) 27

212 In the diagram below of parallelogram $ABCD$ with diagonals \overline{AC} and \overline{BD} , $m\angle 1 = 45$ and $m\angle DCB = 120$.

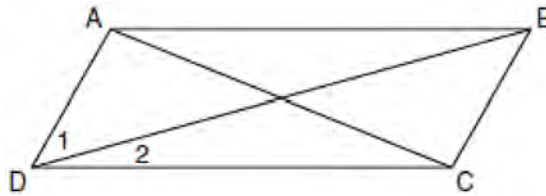

What is the measure of $\angle 2$?

- 1) 15°
- 2) 30°
- 3) 45°
- 4) 60°

213 What is the slope of a line perpendicular to the line whose equation is $y = -\frac{2}{3}x - 5$?

- 1) $-\frac{3}{2}$
- 2) $-\frac{2}{3}$
- 3) $\frac{2}{3}$
- 4) $\frac{3}{2}$

214 What is the negation of the statement “The Sun is shining”?

- 1) It is cloudy.
- 2) It is daytime.
- 3) It is not raining.
- 4) The Sun is not shining.

215 The statement " x is a multiple of 3, and x is an even integer" is true when x is equal to

- 1) 9
- 2) 8
- 3) 3
- 4) 6

216 On the set of axes below, Geoff drew rectangle $ABCD$. He will transform the rectangle by using the translation $(x,y) \rightarrow (x+2,y+1)$ and then will reflect the translated rectangle over the x -axis.

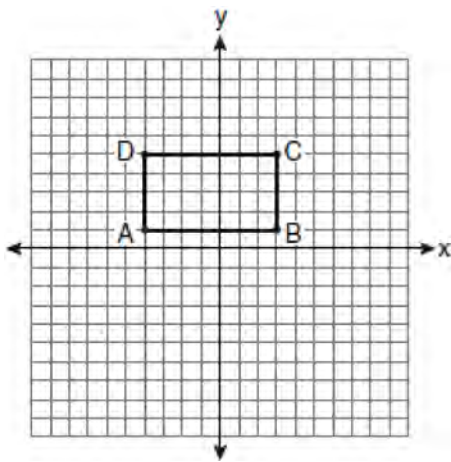

What will be the area of the rectangle after these transformations?

- 1) exactly 28 square units
- 2) less than 28 square units
- 3) greater than 28 square units
- 4) It cannot be determined from the information given.

217 The volume of a cylinder is $12,566.4 \text{ cm}^3$. The height of the cylinder is 8 cm. Find the radius of the cylinder to the *nearest tenth of a centimeter*.

218 Which equation represents circle K shown in the graph below?

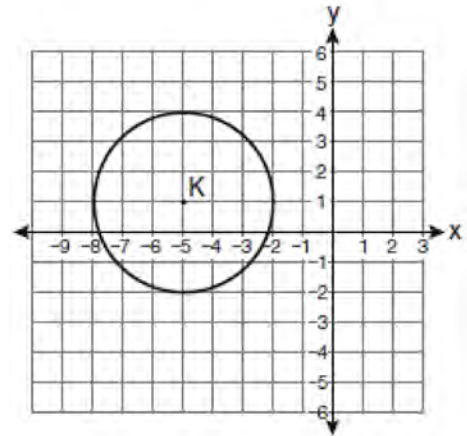

- 1) $(x+5)^2 + (y-1)^2 = 3$
- 2) $(x+5)^2 + (y-1)^2 = 9$
- 3) $(x-5)^2 + (y+1)^2 = 3$
- 4) $(x-5)^2 + (y+1)^2 = 9$

219 The vertices of $\triangle ABC$ are $A(-1,-2)$, $B(-1,2)$ and $C(6,0)$. Which conclusion can be made about the angles of $\triangle ABC$?

- 1) $m\angle A = m\angle B$
- 2) $m\angle A = m\angle C$
- 3) $m\angle ACB = 90$
- 4) $m\angle ABC = 60$

220 The endpoints of \overline{AB} are $A(3,2)$ and $B(7,1)$. If $\overline{A''B''}$ is the result of the transformation of \overline{AB} under $D_2 \circ T_{-4,3}$ what are the coordinates of A'' and B'' ?

- 1) $A''(-2,10)$ and $B''(6,8)$
- 2) $A''(-1,5)$ and $B''(3,4)$
- 3) $A''(2,7)$ and $B''(10,5)$
- 4) $A''(14,-2)$ and $B''(22,-4)$

Geometry Regents Exam Questions at Random

www.jmap.org

- 221 In the diagram below, car A is parked 7 miles from car B. Sketch the points that are 4 miles from car A and sketch the points that are 4 miles from car B. Label with an **X** all points that satisfy both conditions.

Car A



Car B



- 222 The diagonals of a quadrilateral are congruent but do not bisect each other. This quadrilateral is
- 1) an isosceles trapezoid
 - 2) a parallelogram
 - 3) a rectangle
 - 4) a rhombus

- 223 What is an equation of the line that passes through the point (7,3) and is parallel to the line $4x + 2y = 10$?
- 1) $y = \frac{1}{2}x - \frac{1}{2}$
 - 2) $y = -\frac{1}{2}x + \frac{13}{2}$
 - 3) $y = 2x - 11$
 - 4) $y = -2x + 17$

- 224 In which triangle do the three altitudes intersect outside the triangle?
- 1) a right triangle
 - 2) an acute triangle
 - 3) an obtuse triangle
 - 4) an equilateral triangle

- 225 The diagram below illustrates the construction of \overleftrightarrow{PS} parallel to \overleftrightarrow{RQ} through point P.

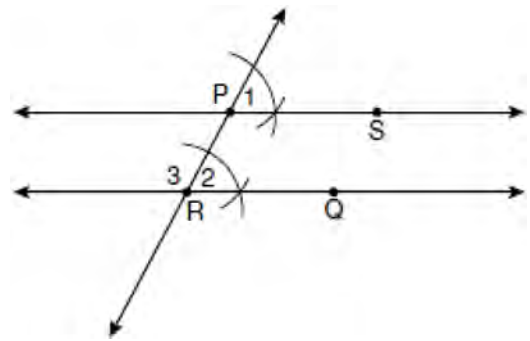

Which statement justifies this construction?

- 1) $m\angle 1 = m\angle 2$
 - 2) $\frac{m\angle 1}{m\angle 2} = \frac{m\angle 3}{m\angle 4}$
 - 3) $\overline{PR} \cong \overline{RQ}$
 - 4) $\overline{PS} \cong \overline{RQ}$
- 226 What is the measure of an interior angle of a regular octagon?
- 1) 45°
 - 2) 60°
 - 3) 120°
 - 4) 135°

- 227 As shown in the diagram below, \overline{AC} bisects $\angle BAD$ and $\angle B \cong \angle D$.

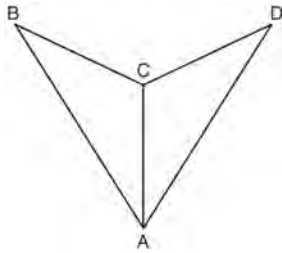

Which method could be used to prove $\triangle ABC \cong \triangle ADC$?

- 1) SSS
 - 2) AAA
 - 3) SAS
 - 4) AAS
- 228 Plane \mathcal{A} is parallel to plane \mathcal{B} . Plane \mathcal{C} intersects plane \mathcal{A} in line m and intersects plane \mathcal{B} in line n . Lines m and n are
- 1) intersecting
 - 2) parallel
 - 3) perpendicular
 - 4) skew

- 229 In the diagram below of isosceles trapezoid $DEFG$, $\overline{DE} \parallel \overline{GF}$, $DE = 4x - 2$, $EF = 3x + 2$, $FG = 5x - 3$, and $GD = 2x + 5$. Find the value of x .

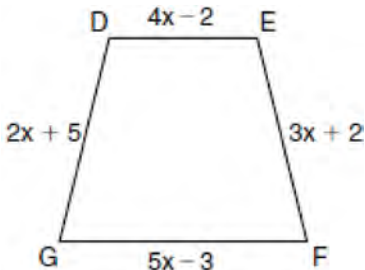

- 230 In the diagram below of $\triangle PAO$, \overline{AP} is tangent to circle O at point A , $OB = 7$, and $BP = 18$.

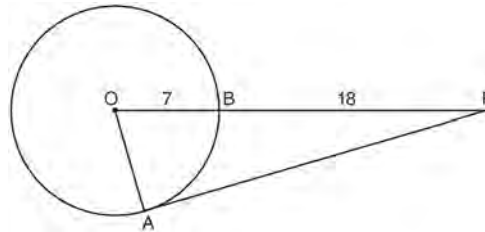

What is the length of \overline{AP} ?

- 1) 10
 - 2) 12
 - 3) 17
 - 4) 24
- 231 Triangle ABC has vertices $A(3,3)$, $B(7,9)$, and $C(11,3)$. Determine the point of intersection of the medians, and state its coordinates. [The use of the set of axes below is optional.]

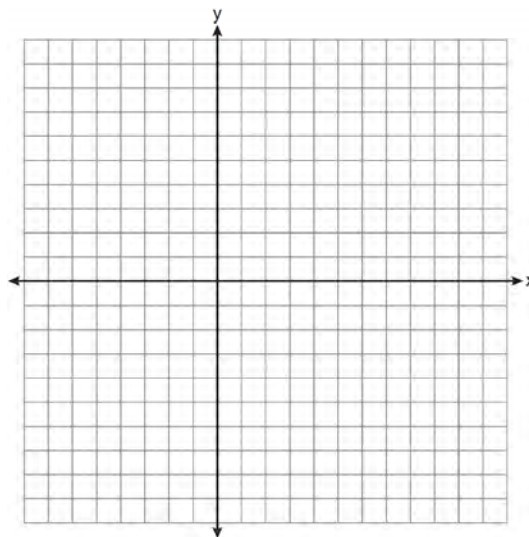

- 232 In the diagram below of regular pentagon $ABCDE$, \overline{EB} is drawn.

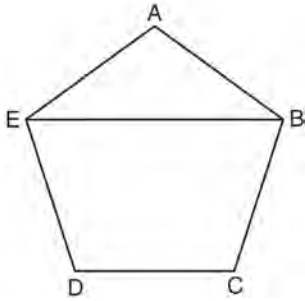

What is the measure of $\angle AEB$?

- 1) 36°
 - 2) 54°
 - 3) 72°
 - 4) 108°
- 233 In the diagram below of $\triangle ACT$, D is the midpoint of \overline{AC} , O is the midpoint of \overline{AT} , and G is the midpoint of \overline{CT} .

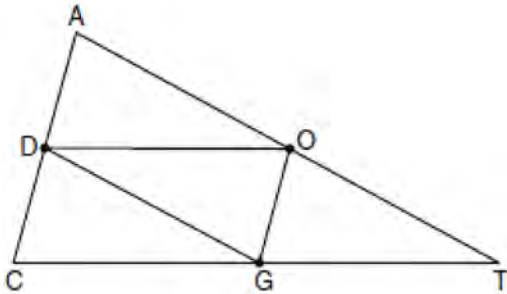

If $AC = 10$, $AT = 18$, and $CT = 22$, what is the perimeter of parallelogram $CDOG$?

- 1) 21
- 2) 25
- 3) 32
- 4) 40

- 234 A city is planning to build a new park. The park must be equidistant from school A at $(3, 3)$ and school B at $(3, -5)$. The park also must be exactly 5 miles from the center of town, which is located at the origin on the coordinate graph. Each unit on the graph represents 1 mile. On the set of axes below, sketch the compound loci and label with an **X** all possible locations for the new park.

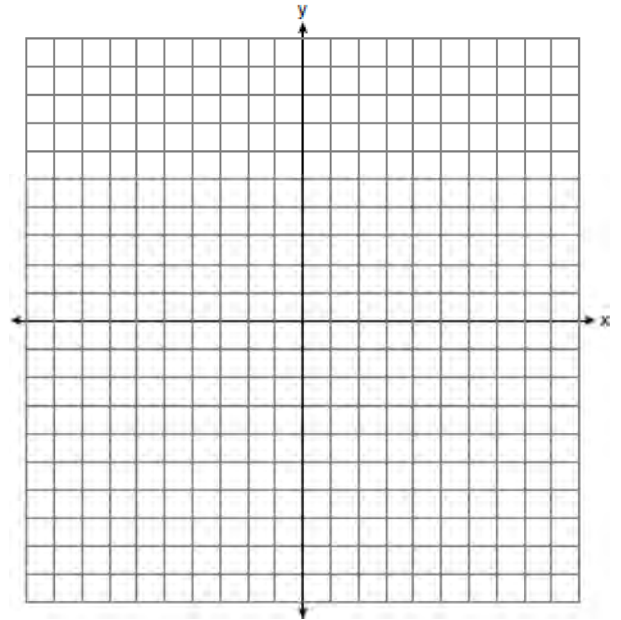

- 235 What is the solution of the following system of equations?

$$y = (x + 3)^2 - 4$$

$$y = 2x + 5$$

- 1) $(0, -4)$
- 2) $(-4, 0)$
- 3) $(-4, -3)$ and $(0, 5)$
- 4) $(-3, -4)$ and $(5, 0)$

- 236 A packing carton in the shape of a triangular prism is shown in the diagram below.

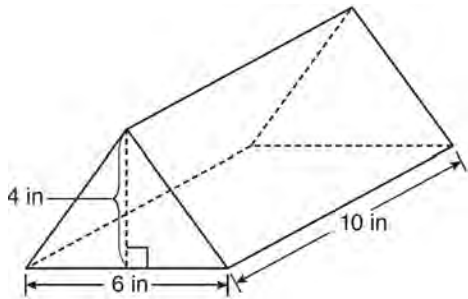

What is the volume, in cubic inches, of this carton?

- 1) 20
- 2) 60
- 3) 120
- 4) 240

- 237 A straightedge and compass were used to create the construction below. Arc EF was drawn from point B , and arcs with equal radii were drawn from E and F .

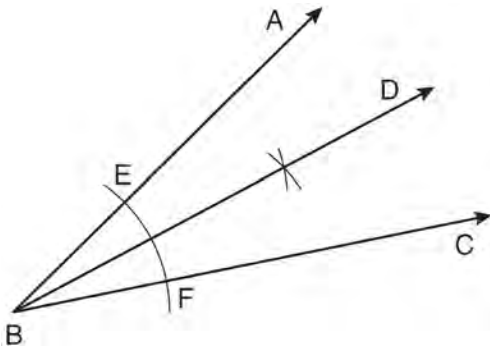

Which statement is *false*?

- 1) $m\angle ABD = m\angle DBC$
- 2) $\frac{1}{2}(m\angle ABC) = m\angle ABD$
- 3) $2(m\angle DBC) = m\angle ABC$
- 4) $2(m\angle ABC) = m\angle CBD$

- 238 Given: Quadrilateral $ABCD$ has vertices $A(-5,6)$, $B(6,6)$, $C(8,-3)$, and $D(-3,-3)$.

Prove: Quadrilateral $ABCD$ is a parallelogram but is neither a rhombus nor a rectangle. [The use of the grid below is optional.]

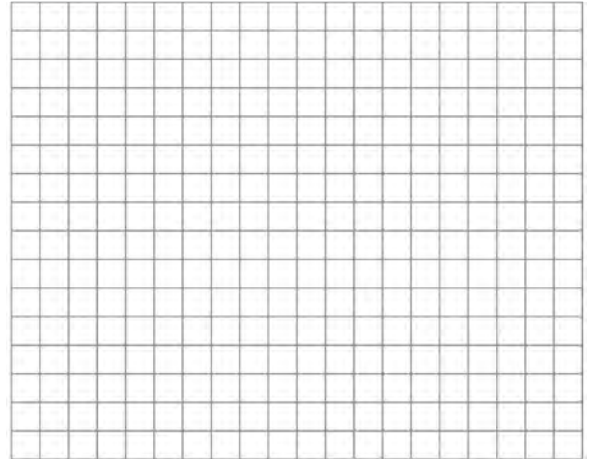

- 239 In the diagram below of quadrilateral $ABCD$ with diagonal \overline{BD} , $m\angle A = 93$, $m\angle ADB = 43$, $m\angle C = 3x + 5$, $m\angle BDC = x + 19$, and $m\angle DBC = 2x + 6$. Determine if \overline{AB} is parallel to \overline{DC} . Explain your reasoning.

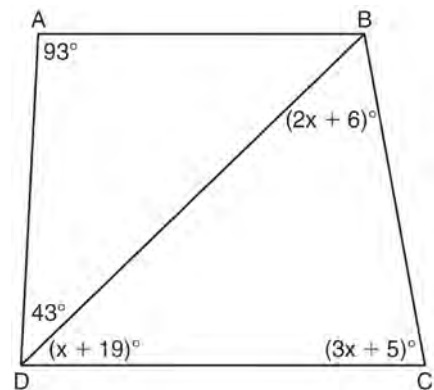

Geometry Regents Exam Questions at Random

www.jmap.org

- 240 The vertices of $\triangle ABC$ are $A(3,2)$, $B(6,1)$, and $C(4,6)$. Identify and graph a transformation of $\triangle ABC$ such that its image, $\triangle A'B'C'$, results in $\overline{AB} \parallel \overline{A'B'}$.

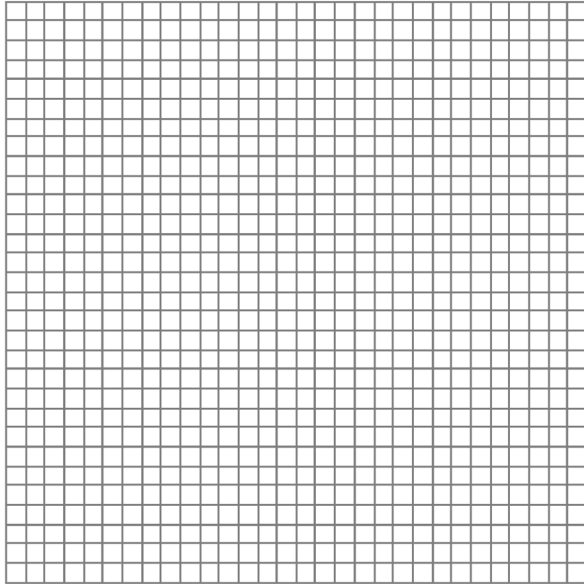

- 241 The coordinates of point A are $(-3a, 4b)$. If point A' is the image of point A reflected over the line $y = x$, the coordinates of A' are
- 1) $(4b, -3a)$
 - 2) $(3a, 4b)$
 - 3) $(-3a, -4b)$
 - 4) $(-4b, -3a)$
- 242 What is the measure of each interior angle of a regular hexagon?
- 1) 60°
 - 2) 120°
 - 3) 135°
 - 4) 270°

- 243 When solved graphically, what is the solution to the following system of equations?

$$y = x^2 - 4x + 6$$

$$y = x + 2$$

- 1) $(1,4)$
 - 2) $(4,6)$
 - 3) $(1,3)$ and $(4,6)$
 - 4) $(3,1)$ and $(6,4)$
- 244 The diagonal \overline{AC} is drawn in parallelogram $ABCD$. Which method can *not* be used to prove that $\triangle ABC \cong \triangle CDA$?
- 1) SSS
 - 2) SAS
 - 3) SSA
 - 4) ASA
- 245 A right circular cylinder has a volume of 1,000 cubic inches and a height of 8 inches. What is the radius of the cylinder to the *nearest tenth of an inch*?
- 1) 6.3
 - 2) 11.2
 - 3) 19.8
 - 4) 39.8
- 246 A support beam between the floor and ceiling of a house forms a 90° angle with the floor. The builder wants to make sure that the floor and ceiling are parallel. Which angle should the support beam form with the ceiling?
- 1) 45°
 - 2) 60°
 - 3) 90°
 - 4) 180°

- 247 Write an equation of the perpendicular bisector of the line segment whose endpoints are $(-1, 1)$ and $(7, -5)$. [The use of the grid below is optional]

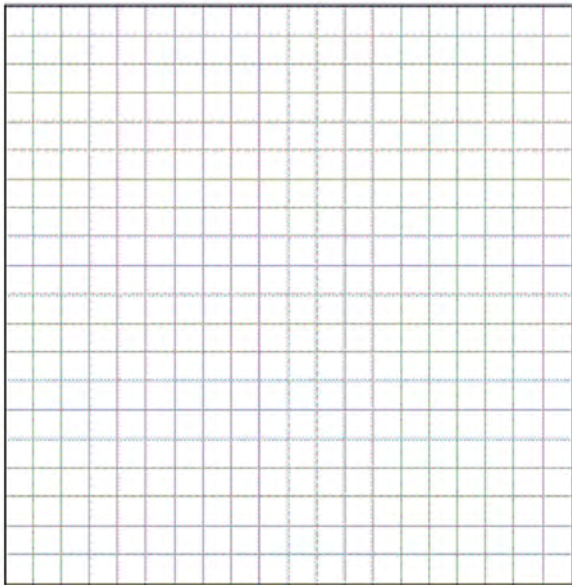

- 248 The diagram below shows the construction of the bisector of $\angle ABC$.

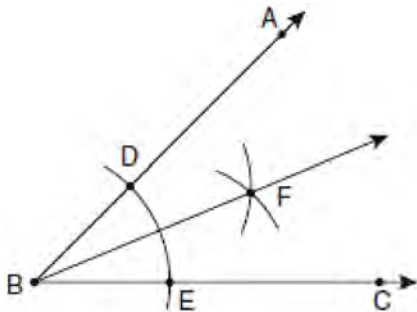

Which statement is *not* true?

- 1) $m\angle EBF = \frac{1}{2} m\angle ABC$
- 2) $m\angle DBF = \frac{1}{2} m\angle ABC$
- 3) $m\angle EBF = m\angle ABC$
- 4) $m\angle DBF = m\angle EBF$

- 249 Which statement is logically equivalent to "If it is warm, then I go swimming"?

- 1) If I go swimming, then it is warm.
- 2) If it is warm, then I do not go swimming.
- 3) If I do not go swimming, then it is not warm.
- 4) If it is not warm, then I do not go swimming.

- 250 Two triangles are similar, and the ratio of each pair of corresponding sides is 2:1. Which statement regarding the two triangles is *not* true?

- 1) Their areas have a ratio of 4:1.
- 2) Their altitudes have a ratio of 2:1.
- 3) Their perimeters have a ratio of 2:1.
- 4) Their corresponding angles have a ratio of 2:1.

- 251 In the diagram below of circle O , diameter \overline{AOB} is perpendicular to chord \overline{CD} at point E , $OA = 6$, and $OE = 2$.

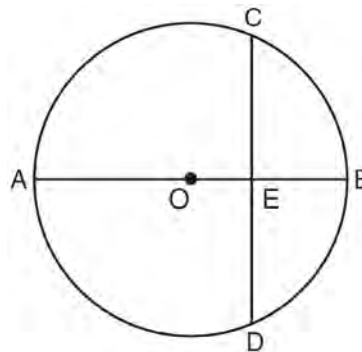

What is the length of \overline{CE} ?

- 1) $4\sqrt{3}$
- 2) $2\sqrt{3}$
- 3) $8\sqrt{2}$
- 4) $4\sqrt{2}$

- 252 In the diagram below of $\triangle AGE$ and $\triangle OLD$, $\angle GAE \cong \angle LOD$, and $\overline{AE} \cong \overline{OD}$.

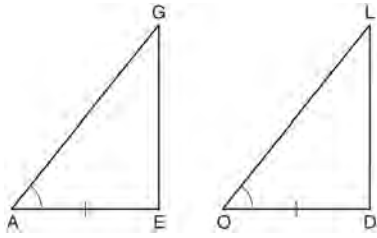

To prove that $\triangle AGE$ and $\triangle OLD$ are congruent by SAS, what other information is needed?

- 1) $\overline{GE} \cong \overline{LD}$
 - 2) $\overline{AG} \cong \overline{OL}$
 - 3) $\angle AGE \cong \angle OLD$
 - 4) $\angle AEG \cong \angle ODL$
- 253 What is the length of the line segment with endpoints $(-6, 4)$ and $(2, -5)$?

- 1) $\sqrt{13}$
- 2) $\sqrt{17}$
- 3) $\sqrt{72}$
- 4) $\sqrt{145}$

- 254 What are the center and radius of a circle whose equation is $(x - A)^2 + (y - B)^2 = C$?

- 1) center = (A, B) ; radius = C
- 2) center = $(-A, -B)$; radius = C
- 3) center = (A, B) ; radius = \sqrt{C}
- 4) center = $(-A, -B)$; radius = \sqrt{C}

- 255 How many common tangent lines can be drawn to the two externally tangent circles shown below?

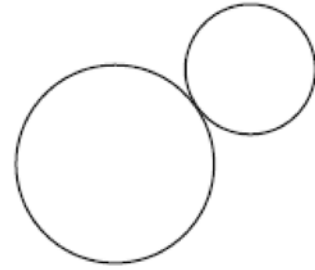

- 1) 1
- 2) 2
- 3) 3
- 4) 4

- 256 Given $\triangle ABC$ with base \overline{AFEDC} , median \overline{BF} , altitude \overline{BD} , and \overline{BE} bisects $\angle ABC$, which conclusion is valid?

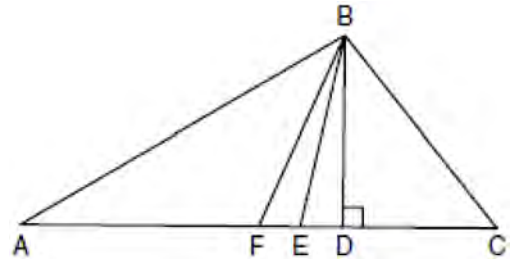

- 1) $\angle FAB \cong \angle ABF$
- 2) $\angle ABF \cong \angle CBD$
- 3) $\overline{CE} \cong \overline{EA}$
- 4) $\overline{CF} \cong \overline{FA}$

- 257 Write an equation of the circle graphed in the diagram below.

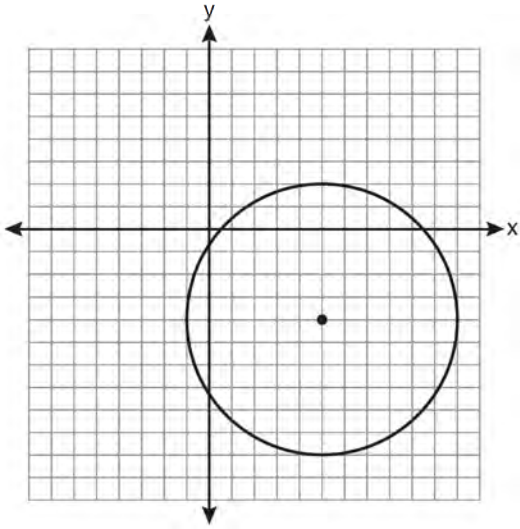

- 258 A polygon is transformed according to the rule: $(x,y) \rightarrow (x+2,y)$. Every point of the polygon moves two units in which direction?
- 1) up
 - 2) down
 - 3) left
 - 4) right

- 259 If the endpoints of \overline{AB} are $A(-4,5)$ and $B(2,-5)$, what is the length of \overline{AB} ?
- 1) $2\sqrt{34}$
 - 2) 2
 - 3) $\sqrt{61}$
 - 4) 8

- 260 How many points are both 4 units from the origin and also 2 units from the line $y = 4$?

- 1) 1
- 2) 2
- 3) 3
- 4) 4

- 261 In the diagram of circle O below, chord \overline{AB} intersects chord \overline{CD} at E , $DE = 2x + 8$, $EC = 3$, $AE = 4x - 3$, and $EB = 4$.

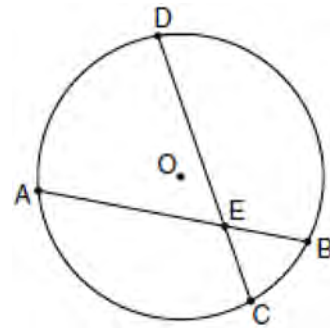

What is the value of x ?

- 1) 1
- 2) 3.6
- 3) 5
- 4) 10.25

- 262 What is the negation of the statement "Squares are parallelograms"?

- 1) Parallelograms are squares.
- 2) Parallelograms are not squares.
- 3) It is not the case that squares are parallelograms.
- 4) It is not the case that parallelograms are squares.

263 In the diagram below, $\triangle ABC \cong \triangle XYZ$.

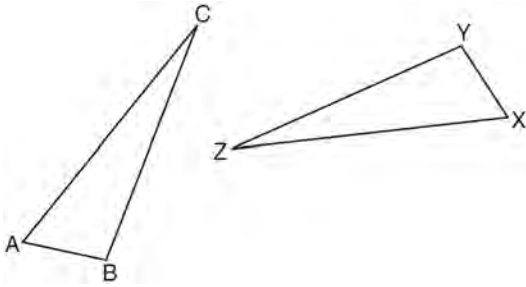

Which statement must be true?

- 1) $\angle C \cong \angle Y$
- 2) $\angle A \cong \angle X$
- 3) $\overline{AC} \cong \overline{YZ}$
- 4) $\overline{CB} \cong \overline{XZ}$

264 What are the center and the radius of the circle whose equation is $(x - 3)^2 + (y + 3)^2 = 36$

- 1) center = $(3, -3)$; radius = 6
- 2) center = $(-3, 3)$; radius = 6
- 3) center = $(3, -3)$; radius = 36
- 4) center = $(-3, 3)$; radius = 36

265 Given three distinct quadrilaterals, a square, a rectangle, and a rhombus, which quadrilaterals must have perpendicular diagonals?

- 1) the rhombus, only
- 2) the rectangle and the square
- 3) the rhombus and the square
- 4) the rectangle, the rhombus, and the square

266 Triangle DEG has the coordinates $D(1, 1)$, $E(5, 1)$, and $G(5, 4)$. Triangle DEG is rotated 90° about the origin to form $\triangle D'E'G'$. On the grid below, graph and label $\triangle DEG$ and $\triangle D'E'G'$. State the coordinates of the vertices D' , E' , and G' . Justify that this transformation preserves distance.

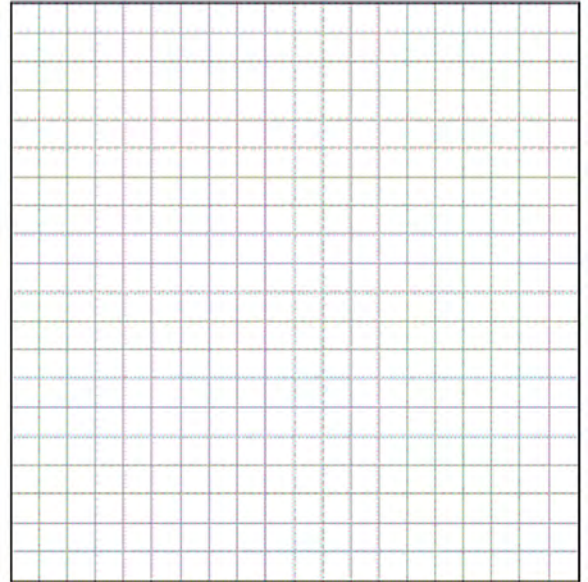

267 Line k is drawn so that it is perpendicular to two distinct planes, P and R . What must be true about planes P and R ?

- 1) Planes P and R are skew.
- 2) Planes P and R are parallel.
- 3) Planes P and R are perpendicular.
- 4) Plane P intersects plane R but is not perpendicular to plane R .

- 268 On the set of axes below, sketch the points that are 5 units from the origin and sketch the points that are 2 units from the line $y = 3$. Label with an **X** all points that satisfy both conditions.

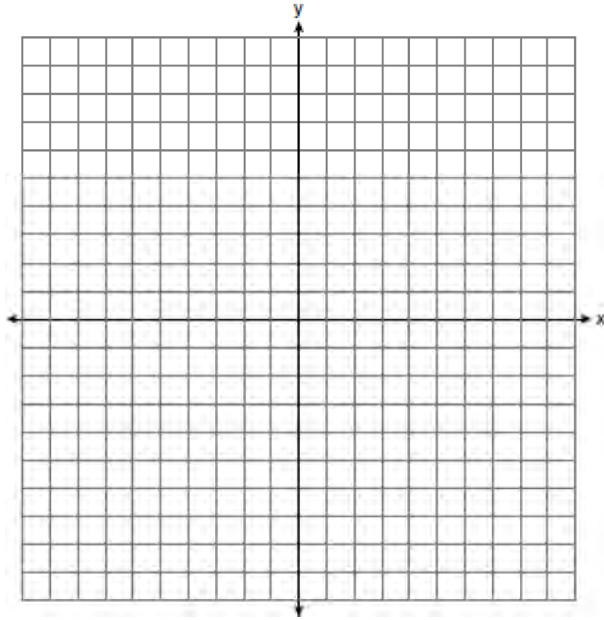

- 269 The diagram below shows $\triangle ABC$, with \overline{AEB} , \overline{ADC} , and $\angle ACB \cong \angle AED$. Prove that $\triangle ABC$ is similar to $\triangle ADE$.

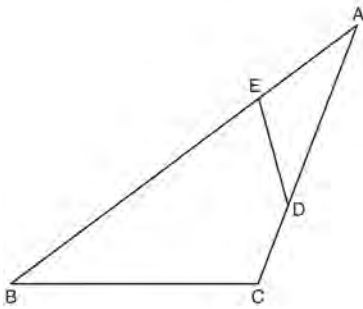

- 270 If $\triangle ABC \sim \triangle ZXY$, $m\angle A = 50$, and $m\angle C = 30$, what is $m\angle X$?
- 1) 30
 - 2) 50
 - 3) 80
 - 4) 100

- 271 In the diagram of $\triangle ABC$ below, $\overline{AB} \cong \overline{AC}$. The measure of $\angle B$ is 40° .

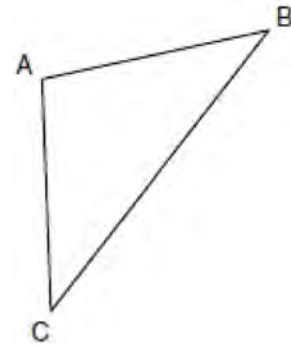

What is the measure of $\angle A$?

- 1) 40°
 - 2) 50°
 - 3) 70°
 - 4) 100°
- 272 Which transformation produces a figure similar but not congruent to the original figure?
- 1) $T_{1,3}$
 - 2) $D_{\frac{1}{2}}$
 - 3) R_{90°
 - 4) $r_{y=x}$

- 273 In the diagram below, line k is perpendicular to plane \mathcal{P} at point T .

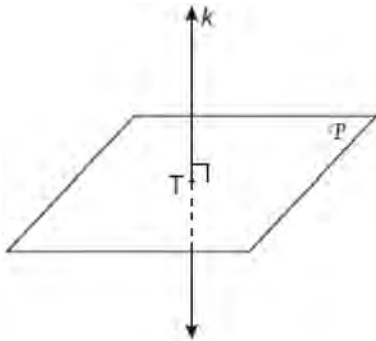

Which statement is true?

- 1) Any point in plane \mathcal{P} also will be on line k .
- 2) Only one line in plane \mathcal{P} will intersect line k .
- 3) All planes that intersect plane \mathcal{P} will pass through T .
- 4) Any plane containing line k is perpendicular to plane \mathcal{P} .

- 274 In the diagram below of circle O , chords \overline{DF} , \overline{DE} , \overline{FG} , and \overline{EG} are drawn such that $m\widehat{DF} : m\widehat{FE} : m\widehat{EG} : m\widehat{GD} = 5 : 2 : 1 : 7$. Identify one pair of inscribed angles that are congruent to each other and give their measure.

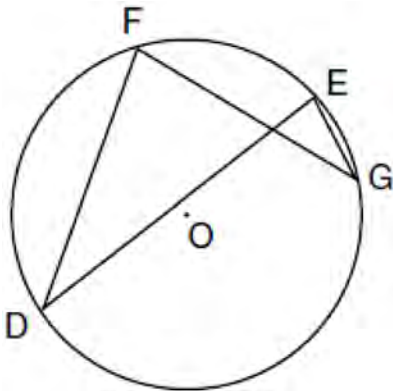

- 275 In the diagram below of $\triangle GJK$, H is a point on \overline{GJ} , $\overline{HJ} \cong \overline{JK}$, $m\angle G = 28$, and $m\angle GJK = 70$. Determine whether $\triangle GHK$ is an isosceles triangle and justify your answer.

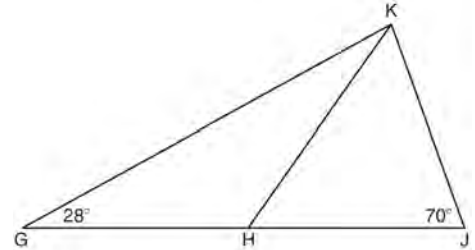

- 276 In the diagram below of right triangle ACB , altitude \overline{CD} is drawn to hypotenuse \overline{AB} .

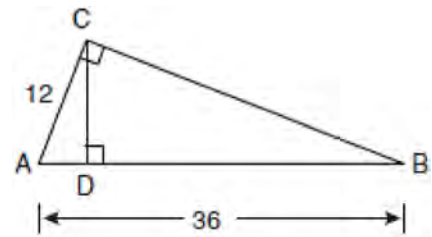

If $AB = 36$ and $AC = 12$, what is the length of \overline{AD} ?

- 1) 32
 - 2) 6
 - 3) 3
 - 4) 4
- 277 Which set of numbers represents the lengths of the sides of a triangle?
- 1) {5, 18, 13}
 - 2) {6, 17, 22}
 - 3) {16, 24, 7}
 - 4) {26, 8, 15}

278 Write an equation for circle O shown on the graph below.

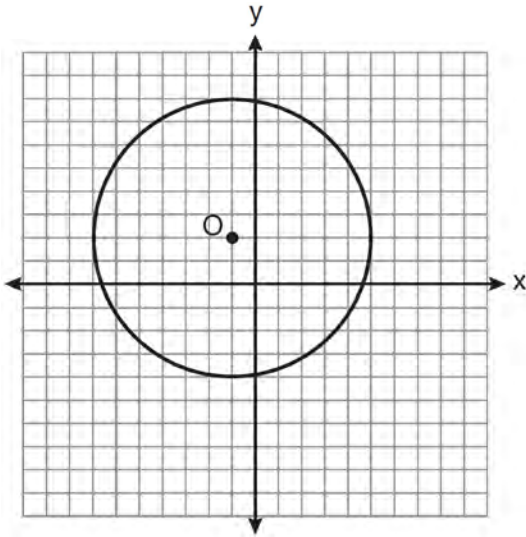

279 In the diagram below of right triangle ACB , altitude \overline{CD} intersects \overline{AB} at D . If $AD = 3$ and $DB = 4$, find the length of CD in simplest radical form.

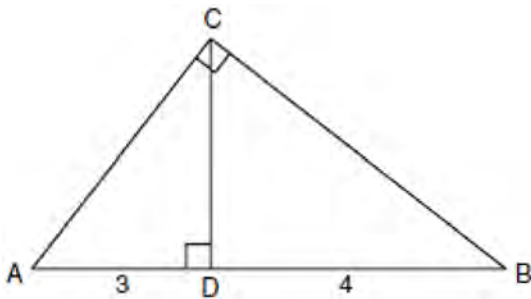

280 In the diagram below of circle C , $m\widehat{QT} = 140$, and $m\angle P = 40$.

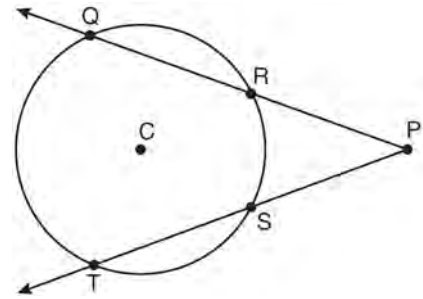

What is $m\widehat{RS}$?

- 1) 50
- 2) 60
- 3) 90
- 4) 110

281 In the diagram below of $\triangle ABC$ with side \overline{AC} extended through D , $m\angle A = 37$ and $m\angle BCD = 117$. Which side of $\triangle ABC$ is the longest side? Justify your answer.

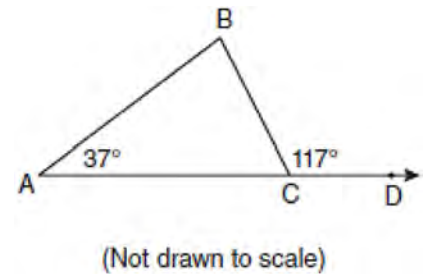

- 282 The diagram below shows isosceles trapezoid $ABCD$ with $\overline{AB} \parallel \overline{DC}$ and $\overline{AD} \cong \overline{BC}$. If $m\angle BAD = 2x$ and $m\angle BCD = 3x + 5$, find $m\angle BAD$.

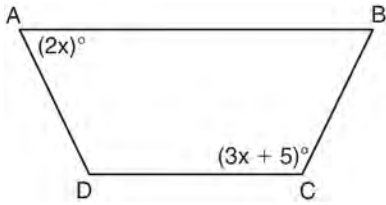

- 283 Given: Quadrilateral $ABCD$, diagonal \overline{AFEC} , $\overline{AE} \cong \overline{FC}$, $\overline{BF} \perp \overline{AC}$, $\overline{DE} \perp \overline{AC}$, $\angle 1 \cong \angle 2$
Prove: $ABCD$ is a parallelogram.

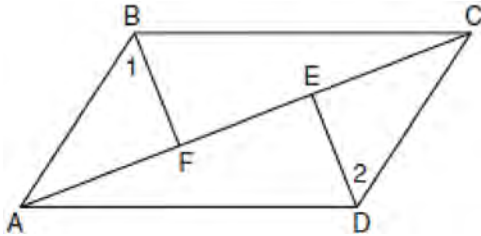

- 284 Using a compass and straightedge, construct the bisector of the angle shown below. [Leave all construction marks.]

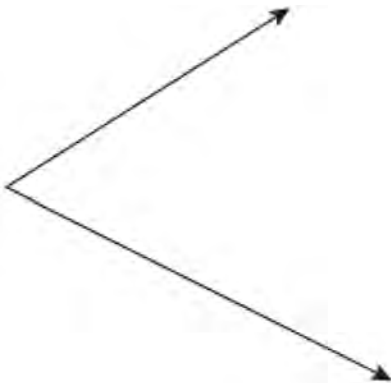

- 285 Lines k_1 and k_2 intersect at point E . Line m is perpendicular to lines k_1 and k_2 at point E .

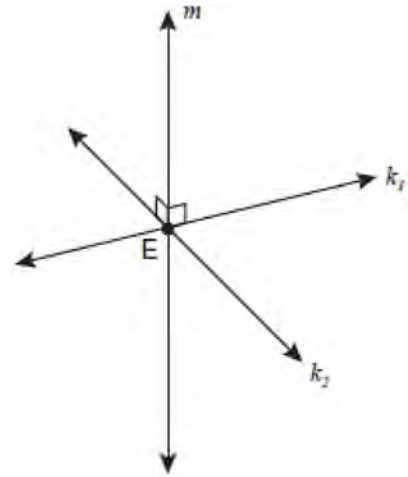

Which statement is always true?

- 1) Lines k_1 and k_2 are perpendicular.
- 2) Line m is parallel to the plane determined by lines k_1 and k_2 .
- 3) Line m is perpendicular to the plane determined by lines k_1 and k_2 .
- 4) Line m is coplanar with lines k_1 and k_2 .

- 286 In the diagram below of $\triangle ABC$, medians \overline{AD} , \overline{BE} , and \overline{CF} intersect at G .

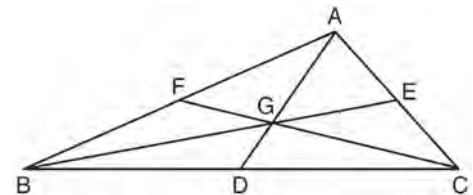

If $CF = 24$, what is the length of \overline{FG} ?

- 1) 8
- 2) 10
- 3) 12
- 4) 16

Geometry Regents Exam Questions at Random

www.jmap.org

287 What is the equation of a line that is parallel to the line whose equation is $y = x + 2$?

- 1) $x + y = 5$
- 2) $2x + y = -2$
- 3) $y - x = -1$
- 4) $y - 2x = 3$

288 In the diagram below of circle O , chords \overline{AB} and \overline{CD} intersect at E .

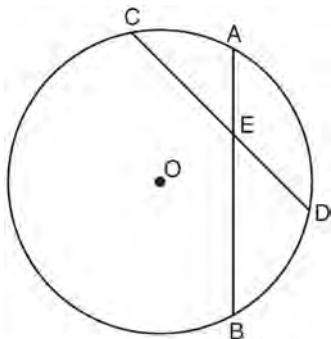

If $\overline{CE} = 10$, $\overline{ED} = 6$, and $\overline{AE} = 4$, what is the length of \overline{EB} ?

- 1) 15
- 2) 12
- 3) 6.7
- 4) 2.4

289 One step in a construction uses the endpoints of \overline{AB} to create arcs with the same radii. The arcs intersect above and below the segment. What is the relationship of \overline{AB} and the line connecting the points of intersection of these arcs?

- 1) collinear
- 2) congruent
- 3) parallel
- 4) perpendicular

290 Given: $\triangle ABC$ with vertices $A(-6, -2)$, $B(2, 8)$, and $C(6, -2)$. \overline{AB} has midpoint D , \overline{BC} has midpoint E , and \overline{AC} has midpoint F .

Prove: $ADEF$ is a parallelogram
 $ADEF$ is *not* a rhombus

[The use of the grid is optional.]

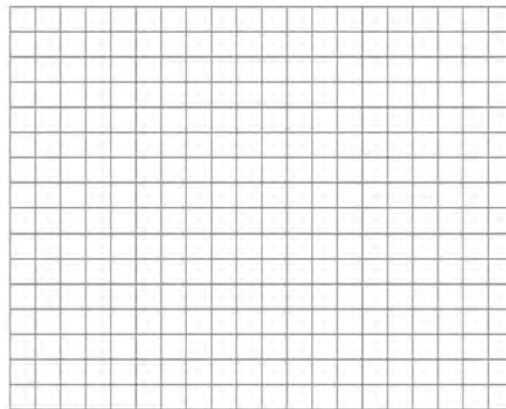

291 In the diagram below, circle O has a radius of 5, and $\overline{CE} = 2$. Diameter \overline{AC} is perpendicular to chord \overline{BD} at E .

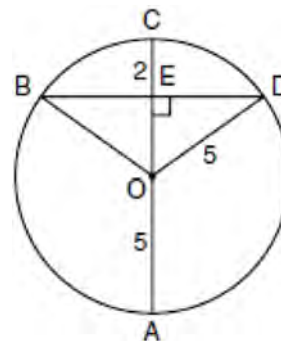

What is the length of \overline{BD} ?

- 1) 12
- 2) 10
- 3) 8
- 4) 4

- 292 A rectangular prism has a volume of $3x^2 + 18x + 24$. Its base has a length of $x + 2$ and a width of 3. Which expression represents the height of the prism?
- 1) $x + 4$
 - 2) $x + 2$
 - 3) 3
 - 4) $x^2 + 6x + 8$

- 293 What is the image of the point $(2, -3)$ after the transformation $r_{y\text{-axis}}$?
- 1) $(2, 3)$
 - 2) $(-2, -3)$
 - 3) $(-2, 3)$
 - 4) $(-3, 2)$

- 294 The endpoints of \overline{CD} are $C(-2, -4)$ and $D(6, 2)$. What are the coordinates of the midpoint of \overline{CD} ?
- 1) $(2, 3)$
 - 2) $(2, -1)$
 - 3) $(4, -2)$
 - 4) $(4, 3)$

- 295 What is the equation of a line that passes through the point $(-3, -11)$ and is parallel to the line whose equation is $2x - y = 4$?
- 1) $y = 2x + 5$
 - 2) $y = 2x - 5$
 - 3) $y = \frac{1}{2}x + \frac{25}{2}$
 - 4) $y = -\frac{1}{2}x - \frac{25}{2}$

- 296 On the set of axes below, graph and label $\triangle DEF$ with vertices at $D(-4, -4)$, $E(-2, 2)$, and $F(8, -2)$. If G is the midpoint of \overline{EF} and H is the midpoint of \overline{DF} , state the coordinates of G and H and label $\overline{GH} \parallel \overline{DE}$. Explain why $\overline{GH} \parallel \overline{DE}$.

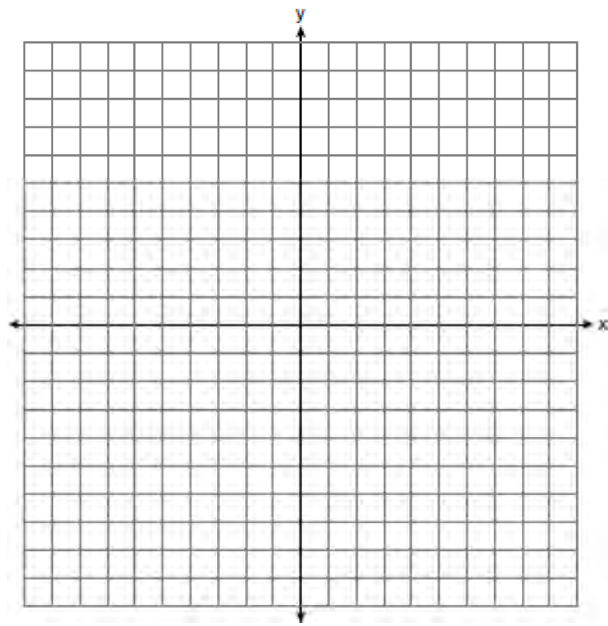

- 297 The equation of a circle is $x^2 + (y - 7)^2 = 16$. What are the center and radius of the circle?
- 1) center = $(0, 7)$; radius = 4
 - 2) center = $(0, 7)$; radius = 16
 - 3) center = $(0, -7)$; radius = 4
 - 4) center = $(0, -7)$; radius = 16

- 298 The endpoints of \overline{PQ} are $P(-3, 1)$ and $Q(4, 25)$. Find the length of \overline{PQ} .

299 What is an equation of the circle with a radius of 5 and center at $(1, -4)$?

- 1) $(x + 1)^2 + (y - 4)^2 = 5$
- 2) $(x - 1)^2 + (y + 4)^2 = 5$
- 3) $(x + 1)^2 + (y - 4)^2 = 25$
- 4) $(x - 1)^2 + (y + 4)^2 = 25$

300 In the diagram below of $\triangle PRT$, Q is a point on \overline{PR} , S is a point on \overline{TR} , \overline{QS} is drawn, and $\angle RPT \cong \angle RSQ$.

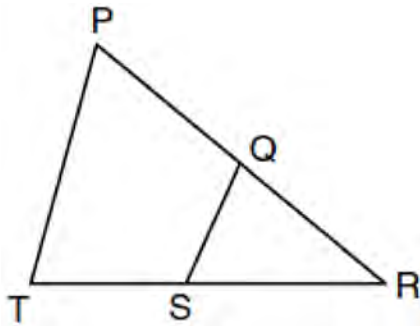

Which reason justifies the conclusion that $\triangle PRT \sim \triangle SRQ$?

- 1) AA
- 2) ASA
- 3) SAS
- 4) SSS

301 Line segment \overline{AB} has endpoints $A(2, -3)$ and $B(-4, 6)$. What are the coordinates of the midpoint of \overline{AB} ?

- 1) $(-2, 3)$
- 2) $\left(-1, 1\frac{1}{2}\right)$
- 3) $(-1, 3)$
- 4) $\left(3, 4\frac{1}{2}\right)$

302 In the diagram below, the vertices of $\triangle DEF$ are the midpoints of the sides of equilateral triangle ABC , and the perimeter of $\triangle ABC$ is 36 cm.

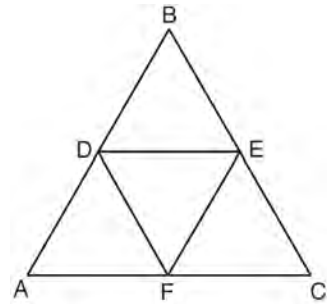

What is the length, in centimeters, of \overline{EF} ?

- 1) 6
- 2) 12
- 3) 18
- 4) 4

303 In the diagram below of $\triangle BCD$, side \overline{DB} is extended to point A.

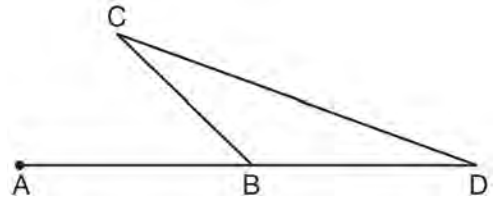

Which statement must be true?

- 1) $m\angle C > m\angle D$
- 2) $m\angle ABC < m\angle D$
- 3) $m\angle ABC > m\angle C$
- 4) $m\angle ABC > m\angle C + m\angle D$

304 What is the slope of a line perpendicular to the line whose equation is $5x + 3y = 8$?

- 1) $\frac{5}{3}$
- 2) $\frac{3}{5}$
- 3) $-\frac{3}{5}$
- 4) $-\frac{5}{3}$

305 The diagram below shows the construction of the perpendicular bisector of \overline{AB} .

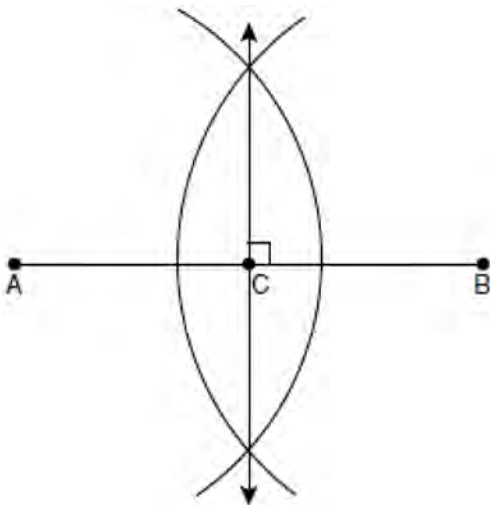

Which statement is *not* true?

- 1) $AC = CB$
- 2) $CB = \frac{1}{2}AB$
- 3) $AC = 2AB$
- 4) $AC + CB = AB$

306 On the diagram of $\triangle ABC$ shown below, use a compass and straightedge to construct the perpendicular bisector of \overline{AC} . [Leave all construction marks.]

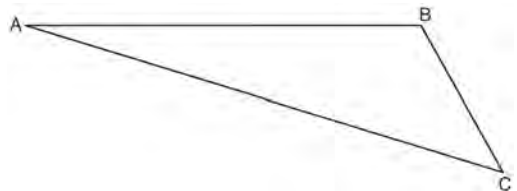

307 $\triangle ABC$ is similar to $\triangle DEF$. The ratio of the length of \overline{AB} to the length of \overline{DE} is 3:1. Which ratio is also equal to 3:1?

- 1) $\frac{m\angle A}{m\angle D}$
- 2) $\frac{m\angle B}{m\angle F}$
- 3) $\frac{\text{area of } \triangle ABC}{\text{area of } \triangle DEF}$
- 4) $\frac{\text{perimeter of } \triangle ABC}{\text{perimeter of } \triangle DEF}$

308 Pentagon $PQRST$ has \overline{PQ} parallel to \overline{TS} . After a translation of $T_{2,-5}$, which line segment is parallel to $\overline{P'Q'}$?

- 1) $\overline{R'Q'}$
- 2) $\overline{R'S'}$
- 3) $\overline{T'S'}$
- 4) $\overline{T'P'}$

309 Triangle PQR has angles in the ratio of 2:3:5. Which type of triangle is $\triangle PQR$?

- 1) acute
- 2) isosceles
- 3) obtuse
- 4) right

310 Based on the diagram below, which statement is true?

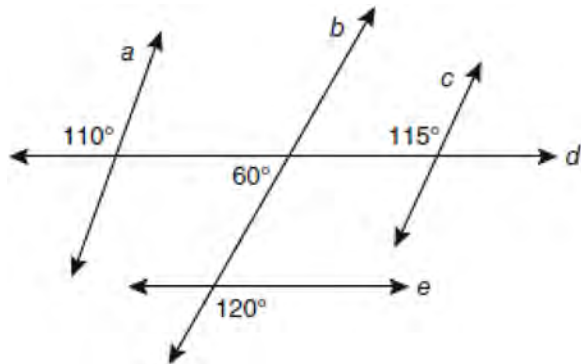

- 1) $a \parallel b$
- 2) $a \parallel c$
- 3) $b \parallel c$
- 4) $d \parallel e$

311 In $\triangle ABC$, $AB = 7$, $BC = 8$, and $AC = 9$. Which list has the angles of $\triangle ABC$ in order from smallest to largest?

- 1) $\angle A, \angle B, \angle C$
- 2) $\angle B, \angle A, \angle C$
- 3) $\angle C, \angle B, \angle A$
- 4) $\angle C, \angle A, \angle B$

312 Point A is not contained in plane \mathcal{B} . How many lines can be drawn through point A that will be perpendicular to plane \mathcal{B} ?

- 1) one
- 2) two
- 3) zero
- 4) infinite

313 In the diagram below, circle A and circle B are shown.

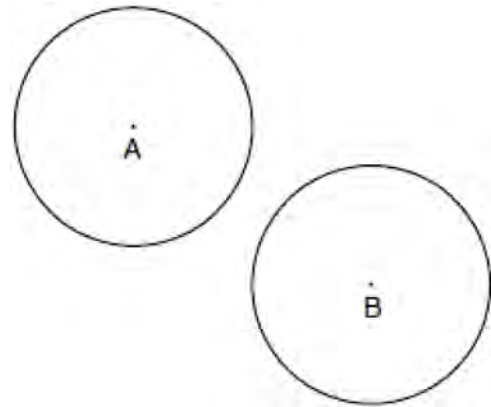

What is the total number of lines of tangency that are common to circle A and circle B ?

- 1) 1
- 2) 2
- 3) 3
- 4) 4

314 Which equation represents the perpendicular bisector of \overline{AB} whose endpoints are $A(8, 2)$ and $B(0, 6)$?

- 1) $y = 2x - 4$
- 2) $y = -\frac{1}{2}x + 2$
- 3) $y = -\frac{1}{2}x + 6$
- 4) $y = 2x - 12$

- 315 On the line segment below, use a compass and straightedge to construct equilateral triangle ABC . [Leave all construction marks.]



- 316 In the diagram below of $\triangle ACT$, $\overleftrightarrow{BE} \parallel \overline{AT}$.

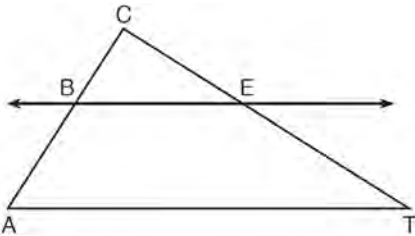

If $CB = 3$, $CA = 10$, and $CE = 6$, what is the length of \overline{ET} ?

- 1) 5
- 2) 14
- 3) 20
- 4) 26

- 317 The figure in the diagram below is a triangular prism.

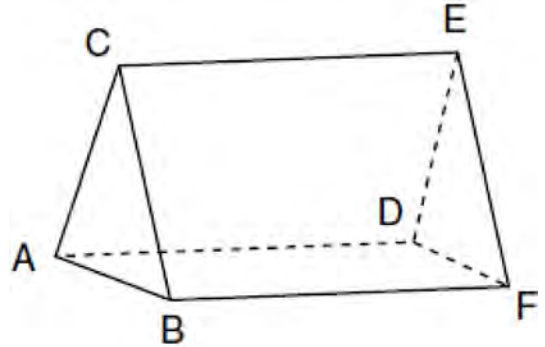

Which statement must be true?

- 1) $\overline{DE} \cong \overline{AB}$
- 2) $\overline{AD} \cong \overline{BC}$
- 3) $\overline{AD} \parallel \overline{CE}$
- 4) $\overline{DE} \parallel \overline{BC}$

- 318 In the diagram below, \overleftrightarrow{AB} is perpendicular to plane $AEFG$.

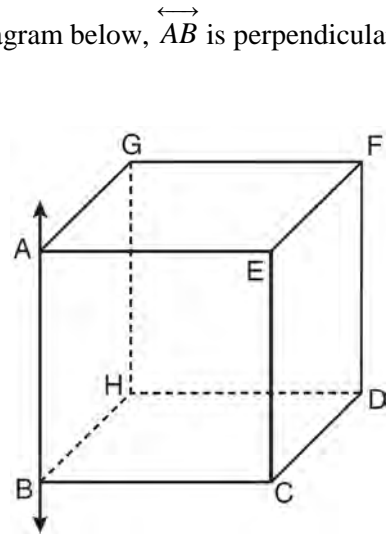

Which plane must be perpendicular to plane $AEFG$?

- 1) $ABCE$
- 2) $BCDH$
- 3) $CDFE$
- 4) $HDFG$

- 319 In the diagram below of $\triangle ABC$, $\overleftrightarrow{TV} \parallel \overline{BC}$, $AT = 5$, $TB = 7$, and $AV = 10$.

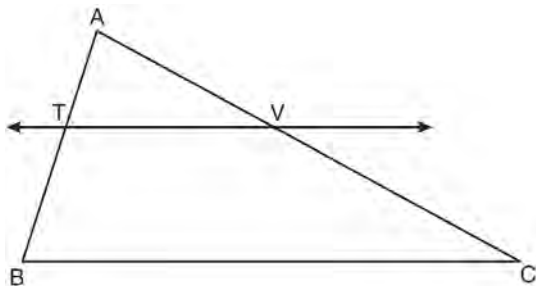

What is the length of \overline{VC} ?

- 1) $3\frac{1}{2}$
 - 2) $7\frac{1}{7}$
 - 3) 14
 - 4) 24
- 320 In the diagram of trapezoid $ABCD$ below, diagonals \overline{AC} and \overline{BD} intersect at E and $\triangle ABC \cong \triangle DCB$.

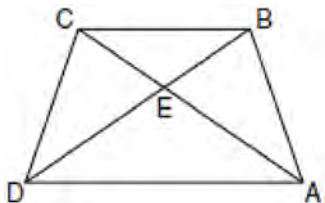

Which statement is true based on the given information?

- 1) $\overline{AC} \cong \overline{BC}$
- 2) $\overline{CD} \cong \overline{AD}$
- 3) $\angle CDE \cong \angle BAD$
- 4) $\angle CDB \cong \angle BAC$

- 321 The coordinates of the vertices of $\triangle ABC$ are $A(1,3)$, $B(-2,2)$ and $C(0,-2)$. On the grid below, graph and label $\triangle A''B''C''$, the result of the composite transformation $D_2 \circ T_{3,-2}$. State the coordinates of A'' , B'' , and C'' .

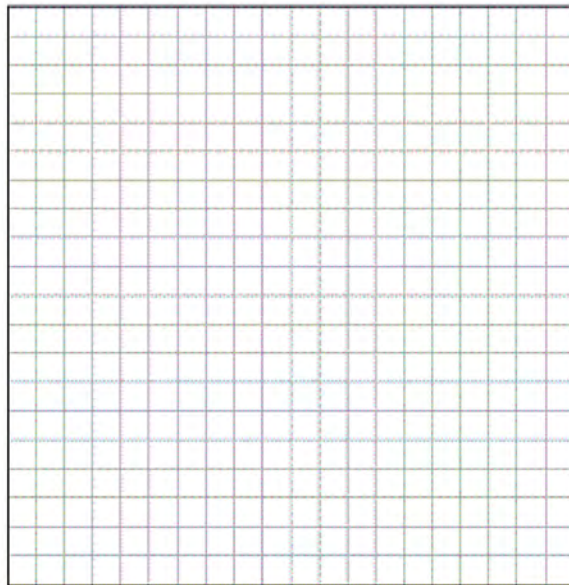

- 322 The diameter of a circle has endpoints at $(-2,3)$ and $(6,3)$. What is an equation of the circle?
- 1) $(x-2)^2 + (y-3)^2 = 16$
 - 2) $(x-2)^2 + (y-3)^2 = 4$
 - 3) $(x+2)^2 + (y+3)^2 = 16$
 - 4) $(x+2)^2 + (y+3)^2 = 4$
- 323 A transformation of a polygon that always preserves both length and orientation is
- 1) dilation
 - 2) translation
 - 3) line reflection
 - 4) glide reflection

- 324 The lines $3y + 1 = 6x + 4$ and $2y + 1 = x - 9$ are
- 1) parallel
 - 2) perpendicular
 - 3) the same line
 - 4) neither parallel nor perpendicular

- 325 In the diagram of circle O below, chord \overline{CD} is parallel to diameter \overline{AOB} and $m\widehat{AC} = 30$.

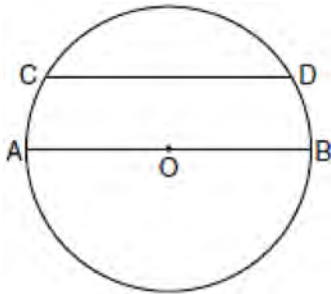

What is $m\widehat{CD}$?

- 1) 150
 - 2) 120
 - 3) 100
 - 4) 60
- 326 In the diagram below, $\triangle ABC \sim \triangle DEF$, $DE = 4$, $AB = x$, $AC = x + 2$, and $DF = x + 6$. Determine the length of \overline{AB} . [Only an algebraic solution can receive full credit.]

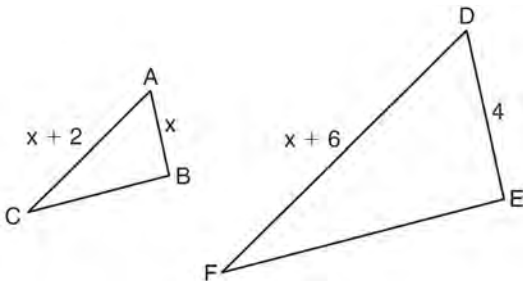

- 327 Using a compass and straightedge, construct the angle bisector of $\angle ABC$ shown below. [Leave all construction marks.]

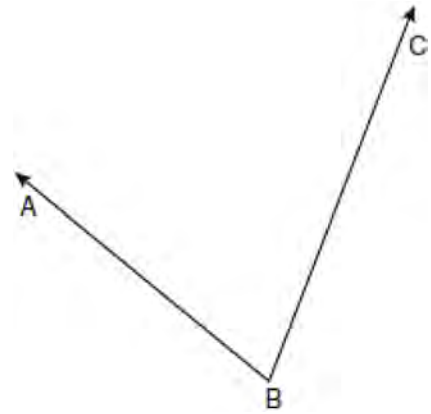

- 328 In the diagram below, which transformation was used to map $\triangle ABC$ to $\triangle A'B'C'$?

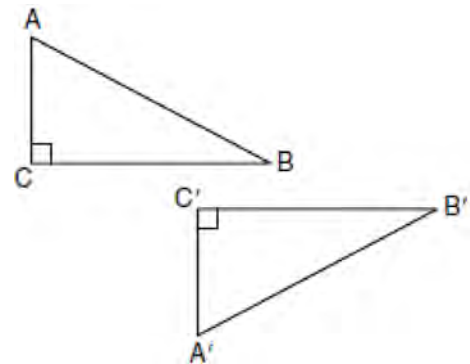

- 1) dilation
- 2) rotation
- 3) reflection
- 4) glide reflection

- 329 The diagram below shows the construction of the center of the circle circumscribed about $\triangle ABC$.

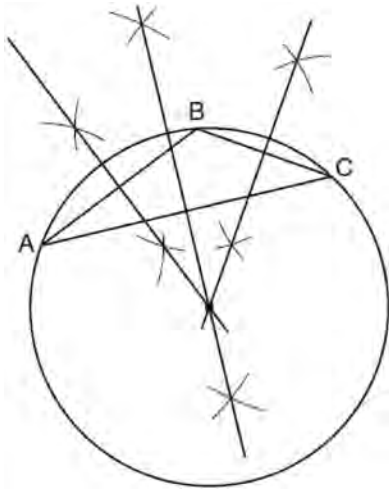

This construction represents how to find the intersection of

- 1) the angle bisectors of $\triangle ABC$
 - 2) the medians to the sides of $\triangle ABC$
 - 3) the altitudes to the sides of $\triangle ABC$
 - 4) the perpendicular bisectors of the sides of $\triangle ABC$
- 330 Which transformation of the line $x = 3$ results in an image that is perpendicular to the given line?
- 1) $r_{x\text{-axis}}$
 - 2) $r_{y\text{-axis}}$
 - 3) $r_{y=x}$
 - 4) $r_{x=1}$

- 331 What is the slope of a line that is perpendicular to the line represented by the equation $x + 2y = 3$?
- 1) -2
 - 2) 2
 - 3) $-\frac{1}{2}$
 - 4) $\frac{1}{2}$

- 332 As shown in the diagram below, a kite needs a vertical and a horizontal support bar attached at opposite corners. The upper edges of the kite are 7 inches, the side edges are x inches, and the vertical support bar is $(x + 1)$ inches.

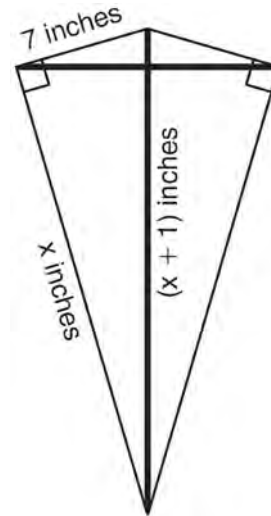

What is the measure, in inches, of the vertical support bar?

- 1) 23
- 2) 24
- 3) 25
- 4) 26

333 Which graph could be used to find the solution to the following system of equations?

$$y = -x + 2$$

$$y = x^2$$

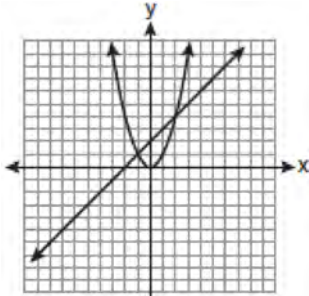

1)

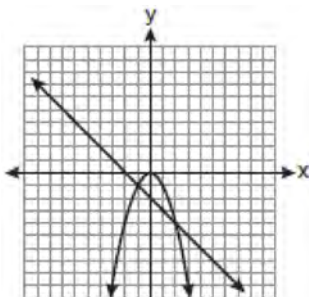

2)

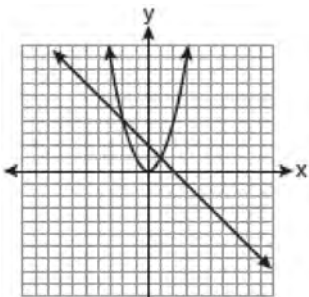

3)

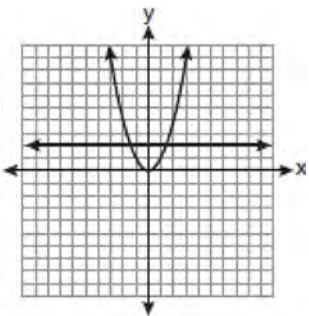

4)

334 If a line segment has endpoints $A(3x + 5, 3y)$ and $B(x - 1, -y)$, what are the coordinates of the midpoint of \overline{AB} ?

- 1) $(x + 3, 2y)$
- 2) $(2x + 2, y)$
- 3) $(2x + 3, y)$
- 4) $(4x + 4, 2y)$

335 Write an equation of the line that passes through the point $(6, -5)$ and is parallel to the line whose equation is $2x - 3y = 11$.

336 As shown on the set of axes below, $\triangle GHS$ has vertices $G(3, 1)$, $H(5, 3)$, and $S(1, 4)$. Graph and state the coordinates of $\triangle G''H''S''$, the image of $\triangle GHS$ after the transformation $T_{-3,1} \circ D_2$.

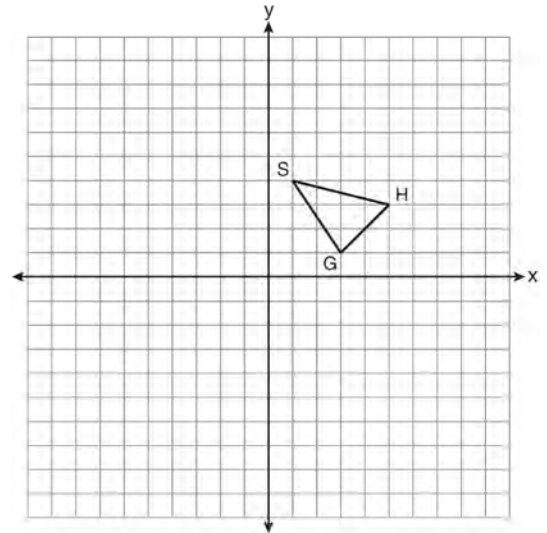

- 337 A quadrilateral whose diagonals bisect each other and are perpendicular is a
- 1) rhombus
 - 2) rectangle
 - 3) trapezoid
 - 4) parallelogram

- 338 In the diagram below, quadrilateral $ABCD$ is inscribed in circle O , $\overline{AB} \parallel \overline{DC}$, and diagonals \overline{AC} and \overline{BD} are drawn. Prove that $\triangle ACD \cong \triangle BDC$.

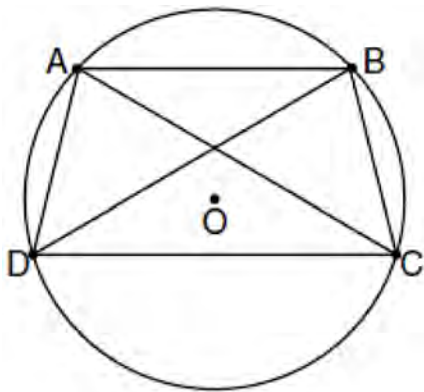

- 339 What is the slope of a line perpendicular to the line whose equation is $2y = -6x + 8$?
- 1) -3
 - 2) $\frac{1}{6}$
 - 3) $\frac{1}{3}$
 - 4) -6

- 340 In the diagram below, lines n and m are cut by transversals p and q .

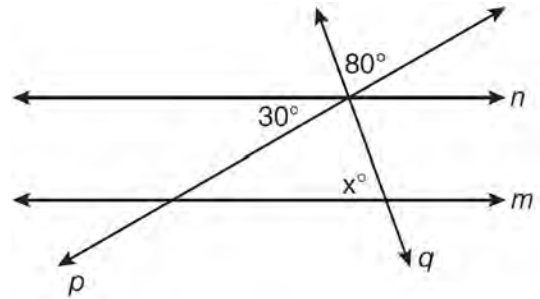

What value of x would make lines n and m parallel?

- 1) 110
 - 2) 80
 - 3) 70
 - 4) 50
- 341 A regular pyramid with a square base is shown in the diagram below.

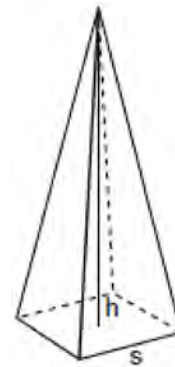

A side, s , of the base of the pyramid is 12 meters, and the height, h , is 42 meters. What is the volume of the pyramid in cubic meters?

- 342 If the surface area of a sphere is represented by 144π , what is the volume in terms of π ?
- 1) 36π
 - 2) 48π
 - 3) 216π
 - 4) 288π