

JEFFERSON MATH PROJECT

REGENTS BY TYPE

The NY Geometry Regents Exams
Fall 2007-August 2010

www.jmap.org

Dear Sir

I have to acknowledge the receipt of your favor of May 14. in which you mention that you have finished the 6. first books of Euclid, plane trigonometry, surveying & algebra and ask whether I think a further pursuit of that branch of science would be useful to you. there are some propositions in the latter books of Euclid, & some of Archimedes, which are useful, & I have no doubt you have been made acquainted with them. trigonometry, so far as this, is most valuable to every man, there is scarcely a day in which he will not resort to it for some of the purposes of common life. the science of calculation also is indispensable as far as the extraction of the square & cube roots; Algebra as far as the quadratic equation & the use of logarithms are often of value in ordinary cases: but all beyond these is but a luxury; a delicious luxury indeed; but not to be indulged in by one who is to have a profession to follow for his subsistence. in this light I view the conic sections, curves of the higher orders, perhaps even spherical trigonometry, Algebraical operations beyond the 2d dimension, and fluxions.

Letter from Thomas Jefferson to William G. Munford, Monticello, June 18, 1799.

Geometry Multiple Choice Regents Exam Questions

- 1 Which transformation produces a figure similar but not congruent to the original figure?
- 1) $T_{1,3}$
 - 2) $D_{\frac{1}{2}}$
 - 3) R_{90°
 - 4) $r_{y=x}$

- 2 $\triangle ABC$ is similar to $\triangle DEF$. The ratio of the length of \overline{AB} to the length of \overline{DE} is 3:1. Which ratio is also equal to 3:1?
- 1) $\frac{m\angle A}{m\angle D}$
 - 2) $\frac{m\angle B}{m\angle F}$
 - 3) $\frac{\text{area of } \triangle ABC}{\text{area of } \triangle DEF}$
 - 4) $\frac{\text{perimeter of } \triangle ABC}{\text{perimeter of } \triangle DEF}$

- 3 The diagram below shows a right pentagonal prism.

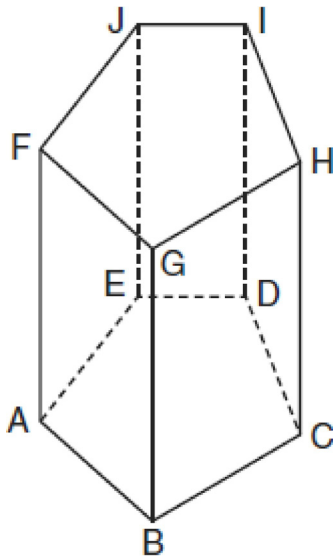

Which statement is always true?

- 1) $\overline{BC} \parallel \overline{ED}$
- 2) $\overline{FG} \parallel \overline{CD}$
- 3) $\overline{FJ} \parallel \overline{IH}$
- 4) $\overline{GB} \parallel \overline{HC}$

- 4 What is the slope of a line perpendicular to the line whose equation is $2y = -6x + 8$?
- 1) -3
 - 2) $\frac{1}{6}$
 - 3) $\frac{1}{3}$
 - 4) -6

- 5 In the diagram below of trapezoid $RSUT$, $\overline{RS} \parallel \overline{TU}$, X is the midpoint of \overline{RT} , and V is the midpoint of \overline{SU} .

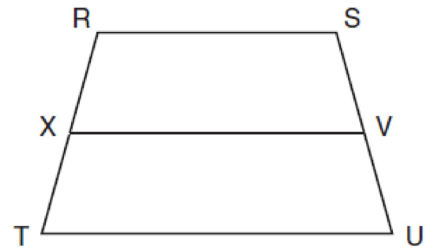

If $RS = 30$ and $XV = 44$, what is the length of \overline{TU} ?

- 1) 37
 - 2) 58
 - 3) 74
 - 4) 118
- 6 The equation of a circle is $x^2 + (y - 7)^2 = 16$. What are the center and radius of the circle?
- 1) center = $(0, 7)$; radius = 4
 - 2) center = $(0, 7)$; radius = 16
 - 3) center = $(0, -7)$; radius = 4
 - 4) center = $(0, -7)$; radius = 16

- 7 In the diagram below of $\triangle ADB$, $m\angle BDA = 90$, $AD = 5\sqrt{2}$, and $AB = 2\sqrt{15}$.

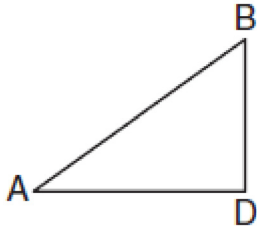

What is the length of \overline{BD} ?

- 1) $\sqrt{10}$
 - 2) $\sqrt{20}$
 - 3) $\sqrt{50}$
 - 4) $\sqrt{110}$
- 8 Point A is not contained in plane \mathcal{B} . How many lines can be drawn through point A that will be perpendicular to plane \mathcal{B} ?
- 1) one
 - 2) two
 - 3) zero
 - 4) infinite

- 9 The rectangle $ABCD$ shown in the diagram below will be reflected across the x -axis.

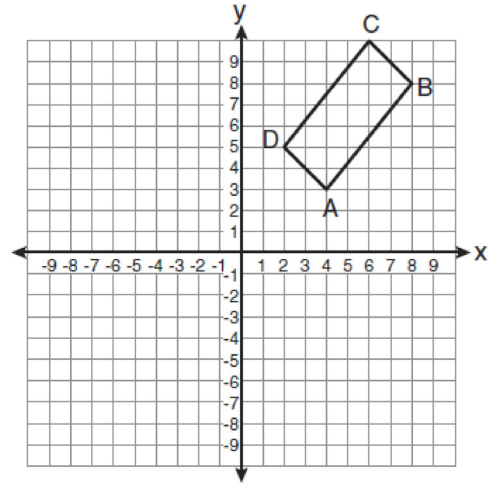

What will *not* be preserved?

- 1) slope of \overline{AB}
 - 2) parallelism of \overline{AB} and \overline{CD}
 - 3) length of \overline{AB}
 - 4) measure of $\angle A$
- 10 If a line segment has endpoints $A(3x + 5, 3y)$ and $B(x - 1, -y)$, what are the coordinates of the midpoint of \overline{AB} ?
- 1) $(x + 3, 2y)$
 - 2) $(2x + 2, y)$
 - 3) $(2x + 3, y)$
 - 4) $(4x + 4, 2y)$
- 11 Which transformation of the line $x = 3$ results in an image that is perpendicular to the given line?
- 1) $r_{x\text{-axis}}$
 - 2) $r_{y\text{-axis}}$
 - 3) $r_{y=x}$
 - 4) $r_{x=1}$

- 12 In the diagram below, $\triangle ABC \cong \triangle XYZ$.

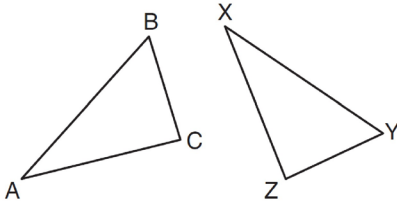

Which two statements identify corresponding congruent parts for these triangles?

- 1) $\overline{AB} \cong \overline{XY}$ and $\angle C \cong \angle Y$
 - 2) $\overline{AB} \cong \overline{YZ}$ and $\angle C \cong \angle X$
 - 3) $\overline{BC} \cong \overline{XY}$ and $\angle A \cong \angle Y$
 - 4) $\overline{BC} \cong \overline{YZ}$ and $\angle A \cong \angle X$
- 13 What is the equation of a line that passes through the point $(-3, -11)$ and is parallel to the line whose equation is $2x - y = 4$?
- 1) $y = 2x + 5$
 - 2) $y = 2x - 5$
 - 3) $y = \frac{1}{2}x + \frac{25}{2}$
 - 4) $y = -\frac{1}{2}x - \frac{25}{2}$
- 14 Which set of numbers represents the lengths of the sides of a triangle?
- 1) $\{5, 18, 13\}$
 - 2) $\{6, 17, 22\}$
 - 3) $\{16, 24, 7\}$
 - 4) $\{26, 8, 15\}$
- 15 What is an equation of the line that passes through the point $(7, 3)$ and is parallel to the line $4x + 2y = 10$?
- 1) $y = \frac{1}{2}x - \frac{1}{2}$
 - 2) $y = -\frac{1}{2}x + \frac{13}{2}$
 - 3) $y = 2x - 11$
 - 4) $y = -2x + 17$

- 16 In the diagram of $\triangle ABC$ and $\triangle DEF$ below, $\overline{AB} \cong \overline{DE}$, $\angle A \cong \angle D$, and $\angle B \cong \angle E$.

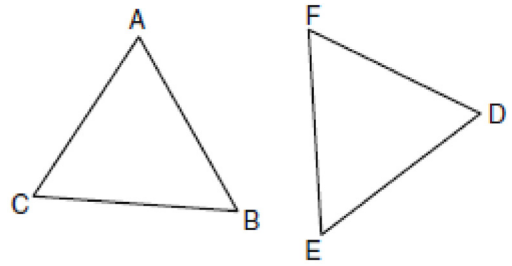

Which method can be used to prove $\triangle ABC \cong \triangle DEF$?

- 1) SSS
 - 2) SAS
 - 3) ASA
 - 4) HL
- 17 Lines k_1 and k_2 intersect at point E . Line m is perpendicular to lines k_1 and k_2 at point E .

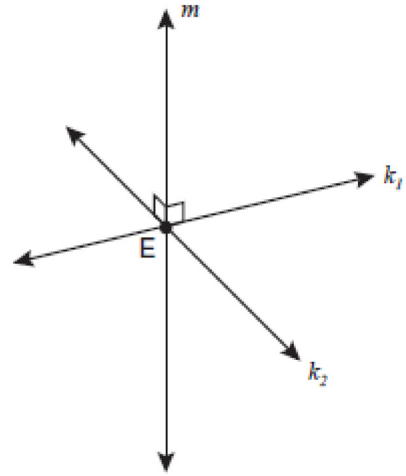

Which statement is always true?

- 1) Lines k_1 and k_2 are perpendicular.
- 2) Line m is parallel to the plane determined by lines k_1 and k_2 .
- 3) Line m is perpendicular to the plane determined by lines k_1 and k_2 .
- 4) Line m is coplanar with lines k_1 and k_2 .

Geometry Multiple Choice Regents Exam Questions

www.jmap.org

- 18 If the surface area of a sphere is represented by 144π , what is the volume in terms of π ?
- 1) 36π
 - 2) 48π
 - 3) 216π
 - 4) 288π
- 19 After a composition of transformations, the coordinates $A(4,2)$, $B(4,6)$, and $C(2,6)$ become $A''(-2,-1)$, $B''(-2,-3)$, and $C''(-1,-3)$, as shown on the set of axes below.

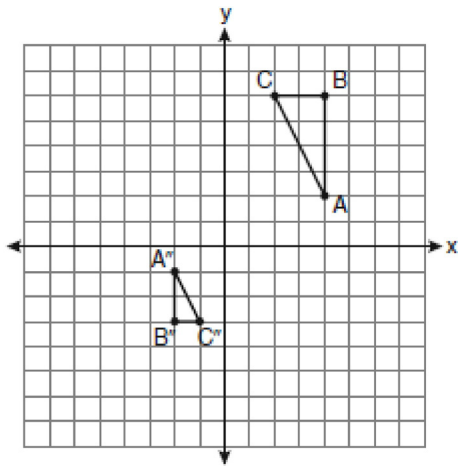

Which composition of transformations was used?

- 1) $R_{180^\circ} \circ D_2$
 - 2) $R_{90^\circ} \circ D_2$
 - 3) $D_{\frac{1}{2}} \circ R_{180^\circ}$
 - 4) $D_{\frac{1}{2}} \circ R_{90^\circ}$
- 20 Which statement is logically equivalent to "If it is warm, then I go swimming"?
- 1) If I go swimming, then it is warm.
 - 2) If it is warm, then I do not go swimming.
 - 3) If I do not go swimming, then it is not warm.
 - 4) If it is not warm, then I do not go swimming.

- 21 In the diagram below of $\triangle PRT$, Q is a point on \overline{PR} , S is a point on \overline{TR} , \overline{QS} is drawn, and $\angle RPT \cong \angle RSQ$.

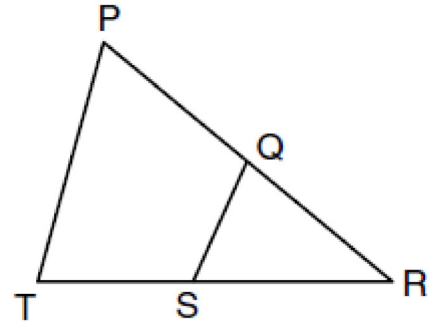

Which reason justifies the conclusion that $\triangle PRT \sim \triangle SRQ$?

- 1) AA
 - 2) ASA
 - 3) SAS
 - 4) SSS
- 22 The diagram below shows a pennant in the shape of an isosceles triangle. The equal sides each measure 13, the altitude is $x + 7$, and the base is $2x$.

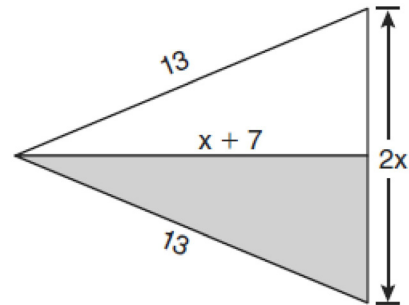

What is the length of the base?

- 1) 5
 - 2) 10
 - 3) 12
 - 4) 24
- 23 In $\triangle PQR$, $PQ = 8$, $QR = 12$, and $RP = 13$. Which statement about the angles of $\triangle PQR$ must be true?
- 1) $m\angle Q > m\angle P > m\angle R$
 - 2) $m\angle Q > m\angle R > m\angle P$
 - 3) $m\angle R > m\angle P > m\angle Q$
 - 4) $m\angle P > m\angle R > m\angle Q$

- 24 In the diagram below of circle C , $m\widehat{QT} = 140$, and $m\angle P = 40$.

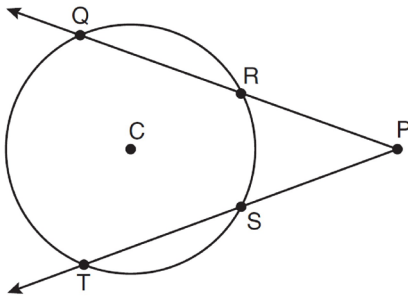

What is $m\widehat{RS}$?

- 1) 50
 - 2) 60
 - 3) 90
 - 4) 110
- 25 Lines j and k intersect at point P . Line m is drawn so that it is perpendicular to lines j and k at point P . Which statement is correct?
- 1) Lines j and k are in perpendicular planes.
 - 2) Line m is in the same plane as lines j and k .
 - 3) Line m is parallel to the plane containing lines j and k .
 - 4) Line m is perpendicular to the plane containing lines j and k .

- 26 Which geometric principle is used in the construction shown below?

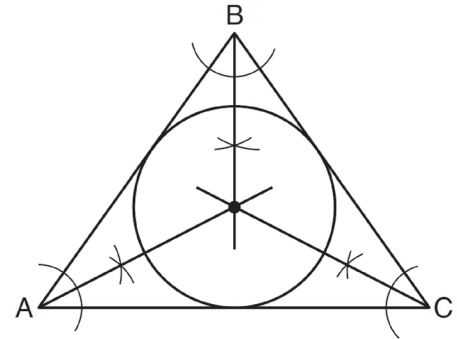

- 1) The intersection of the angle bisectors of a triangle is the center of the inscribed circle.
 - 2) The intersection of the angle bisectors of a triangle is the center of the circumscribed circle.
 - 3) The intersection of the perpendicular bisectors of the sides of a triangle is the center of the inscribed circle.
 - 4) The intersection of the perpendicular bisectors of the sides of a triangle is the center of the circumscribed circle.
- 27 In the diagram below, tangent \overline{PA} and secant \overline{PBC} are drawn to circle O from external point P .

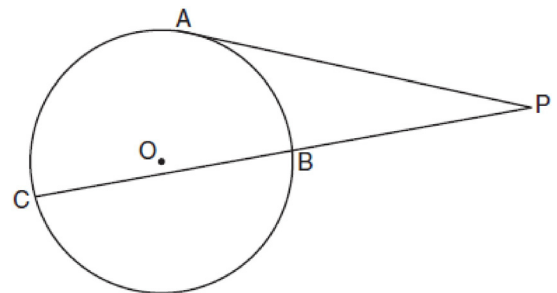

If $PB = 4$ and $BC = 5$, what is the length of \overline{PA} ?

- 1) 20
- 2) 9
- 3) 8
- 4) 6

- 28 A circle is represented by the equation $x^2 + (y + 3)^2 = 13$. What are the coordinates of the center of the circle and the length of the radius?
- 1) $(0, 3)$ and 13
 - 2) $(0, 3)$ and $\sqrt{13}$
 - 3) $(0, -3)$ and 13
 - 4) $(0, -3)$ and $\sqrt{13}$

- 29 In the diagram below, tangent \overline{AB} and secant \overline{ACD} are drawn to circle O from an external point A , $AB = 8$, and $AC = 4$.

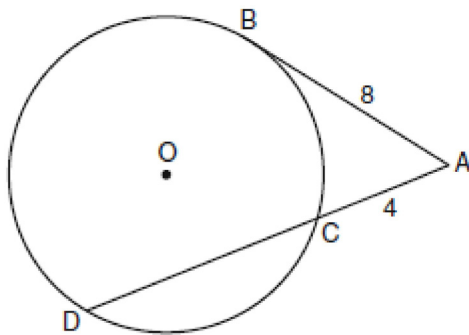

What is the length of \overline{CD} ?

- 1) 16
 - 2) 13
 - 3) 12
 - 4) 10
- 30 If the diagonals of a quadrilateral do *not* bisect each other, then the quadrilateral could be a
- 1) rectangle
 - 2) rhombus
 - 3) square
 - 4) trapezoid

- 31 In the diagram below of $\triangle ACT$, D is the midpoint of \overline{AC} , O is the midpoint of \overline{AT} , and G is the midpoint of \overline{CT} .

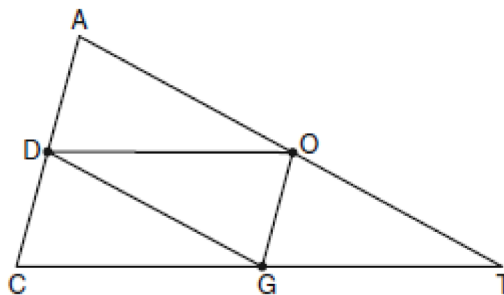

If $AC = 10$, $AT = 18$, and $CT = 22$, what is the perimeter of parallelogram $CDOG$?

- 1) 21
 - 2) 25
 - 3) 32
 - 4) 40
- 32 The diagram below shows the construction of a line through point P perpendicular to line m .

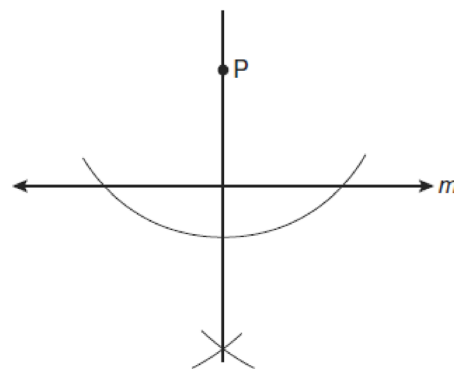

Which statement is demonstrated by this construction?

- 1) If a line is parallel to a line that is perpendicular to a third line, then the line is also perpendicular to the third line.
- 2) The set of points equidistant from the endpoints of a line segment is the perpendicular bisector of the segment.
- 3) Two lines are perpendicular if they are equidistant from a given point.
- 4) Two lines are perpendicular if they intersect to form a vertical line.

- 33 A transformation of a polygon that always preserves both length and orientation is
- 1) dilation
 - 2) translation
 - 3) line reflection
 - 4) glide reflection
- 34 Which transformation can map the letter **S** onto itself?
- 1) glide reflection
 - 2) translation
 - 3) line reflection
 - 4) rotation
- 35 In the diagram below, under which transformation will $\triangle A'B'C'$ be the image of $\triangle ABC$?

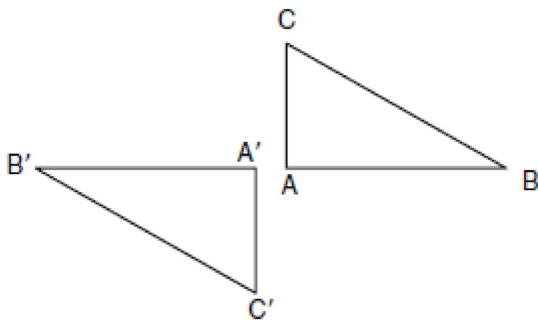

- 1) rotation
 - 2) dilation
 - 3) translation
 - 4) glide reflection
- 36 Isosceles trapezoid $ABCD$ has diagonals \overline{AC} and \overline{BD} . If $AC = 5x + 13$ and $BD = 11x - 5$, what is the value of x ?
- 1) 28
 - 2) $10\frac{3}{4}$
 - 3) 3
 - 4) $\frac{1}{2}$
- 37 In isosceles triangle ABC , $AB = BC$. Which statement will always be true?
- 1) $m\angle B = m\angle A$
 - 2) $m\angle A > m\angle B$
 - 3) $m\angle A = m\angle C$
 - 4) $m\angle C < m\angle B$

- 38 In $\triangle ABC$, point D is on \overline{AB} , and point E is on \overline{BC} such that $\overline{DE} \parallel \overline{AC}$. If $DB = 2$, $DA = 7$, and $DE = 3$, what is the length of \overline{AC} ?
- 1) 8
 - 2) 9
 - 3) 10.5
 - 4) 13.5
- 39 In the diagram below of parallelogram $ABCD$ with diagonals \overline{AC} and \overline{BD} , $m\angle 1 = 45$ and $m\angle DCB = 120$.

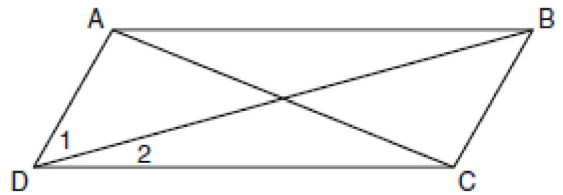

What is the measure of $\angle 2$?

- 1) 15°
 - 2) 30°
 - 3) 45°
 - 4) 60°
- 40 In the diagram below, $\triangle ABC$ is inscribed in circle P . The distances from the center of circle P to each side of the triangle are shown.

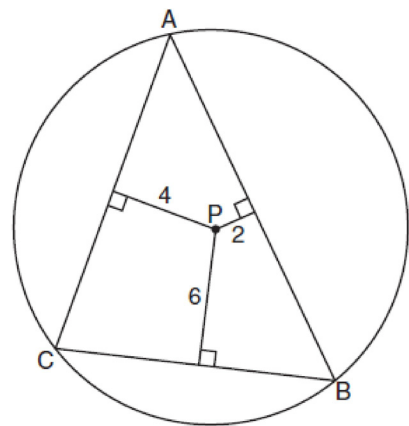

Which statement about the sides of the triangle is true?

- 1) $AB > AC > BC$
- 2) $AB < AC$ and $AC > BC$
- 3) $AC > AB > BC$
- 4) $AC = AB$ and $AB > BC$

- 41 The diagram below shows the construction of the perpendicular bisector of \overline{AB} .

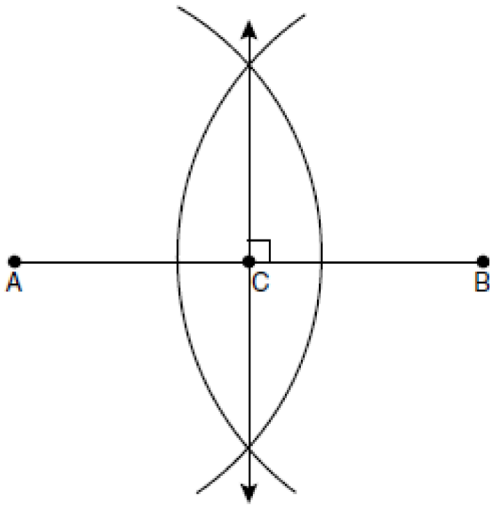

Which statement is *not* true?

- 1) $AC = CB$
- 2) $CB = \frac{1}{2}AB$
- 3) $AC = 2AB$
- 4) $AC + CB = AB$

- 42 Which expression best describes the transformation shown in the diagram below?

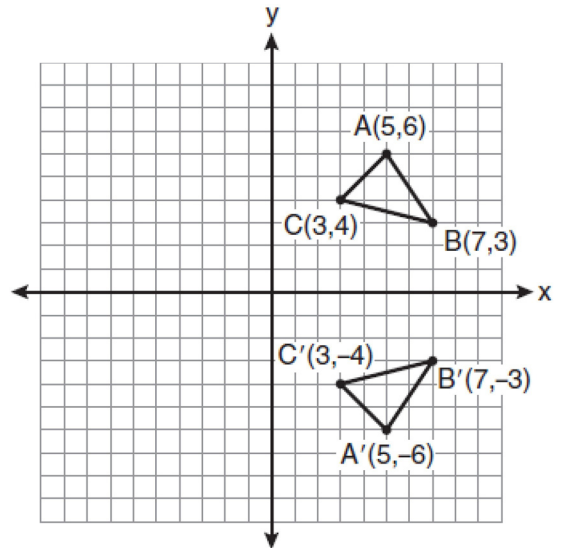

- 1) same orientation; reflection
 - 2) opposite orientation; reflection
 - 3) same orientation; translation
 - 4) opposite orientation; translation
- 43 Which transformation is *not* always an isometry?
- 1) rotation
 - 2) dilation
 - 3) reflection
 - 4) translation
- 44 Which equation represents the circle whose center is $(-2,3)$ and whose radius is 5?
- 1) $(x-2)^2 + (y+3)^2 = 5$
 - 2) $(x+2)^2 + (y-3)^2 = 5$
 - 3) $(x+2)^2 + (y-3)^2 = 25$
 - 4) $(x-2)^2 + (y+3)^2 = 25$
- 45 What is an equation of the line that passes through the point $(-2,5)$ and is perpendicular to the line whose equation is $y = \frac{1}{2}x + 5$?
- 1) $y = 2x + 1$
 - 2) $y = -2x + 1$
 - 3) $y = 2x + 9$
 - 4) $y = -2x - 9$

46 Given $\triangle ABC \sim \triangle DEF$ such that $\frac{AB}{DE} = \frac{3}{2}$. Which statement is *not* true?

- 1) $\frac{BC}{EF} = \frac{3}{2}$
- 2) $\frac{m\angle A}{m\angle D} = \frac{3}{2}$
- 3) $\frac{\text{area of } \triangle ABC}{\text{area of } \triangle DEF} = \frac{9}{4}$
- 4) $\frac{\text{perimeter of } \triangle ABC}{\text{perimeter of } \triangle DEF} = \frac{3}{2}$

47 In the diagram of $\triangle ABC$ and $\triangle EDC$ below, \overline{AE} and \overline{BD} intersect at C , and $\angle CAB \cong \angle CED$.

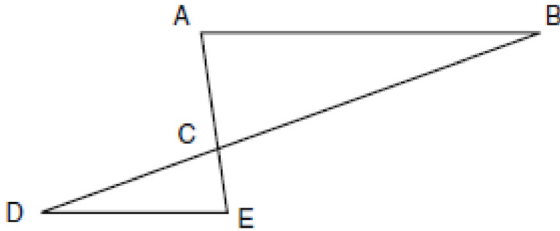

Which method can be used to show that $\triangle ABC$ must be similar to $\triangle EDC$?

- 1) SAS
 - 2) AA
 - 3) SSS
 - 4) HL
- 48 Tangents \overline{PA} and \overline{PB} are drawn to circle O from an external point, P , and radii \overline{OA} and \overline{OB} are drawn. If $m\angle APB = 40$, what is the measure of $\angle AOB$?
- 1) 140°
 - 2) 100°
 - 3) 70°
 - 4) 50°

49 Based on the construction below, which statement must be true?

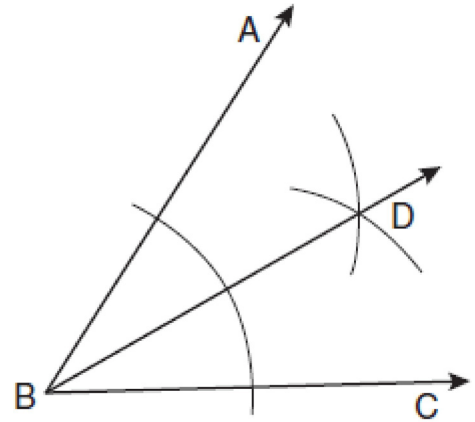

- 1) $m\angle ABD = \frac{1}{2} m\angle CBD$
- 2) $m\angle ABD = m\angle CBD$
- 3) $m\angle ABD = m\angle ABC$
- 4) $m\angle CBD = \frac{1}{2} m\angle ABD$

- 50 Which graph could be used to find the solution to the following system of equations?

$$y = -x + 2$$

$$y = x^2$$

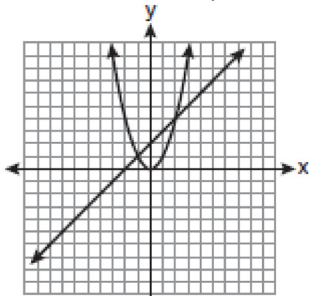

1)

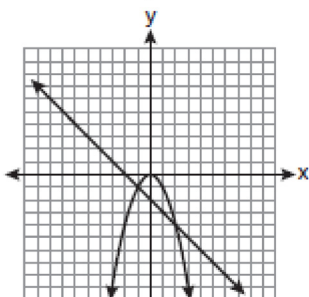

2)

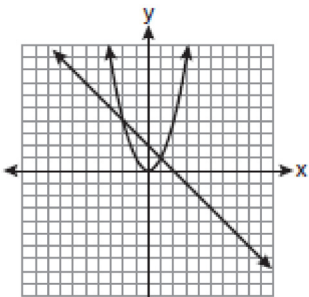

3)

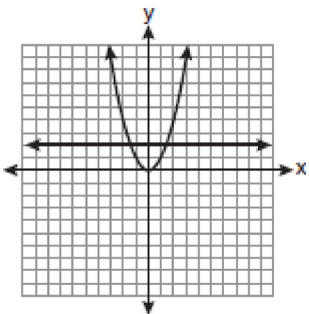

4)

- 51 In three-dimensional space, two planes are parallel and a third plane intersects both of the parallel planes. The intersection of the planes is a
- 1) plane
 - 2) point
 - 3) pair of parallel lines
 - 4) pair of intersecting lines
- 52 In the diagram below of $\triangle ABC$, D is a point on \overline{AB} , $AC = 7$, $AD = 6$, and $BC = 18$.

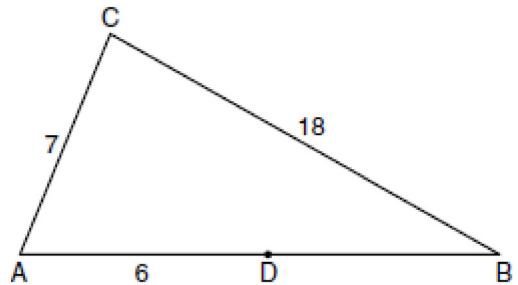

(Not drawn to scale)

The length of \overline{DB} could be

- 1) 5
 - 2) 12
 - 3) 19
 - 4) 25
- 53 Given $\triangle ABC$ with base \overline{AFEDC} , median \overline{BF} , altitude \overline{BD} , and \overline{BE} bisects $\angle ABC$, which conclusion is valid?

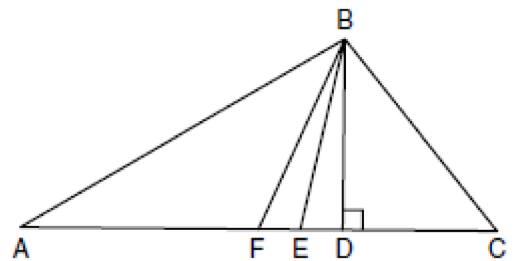

- 1) $\angle FAB \cong \angle ABF$
- 2) $\angle ABF \cong \angle CBD$
- 3) $\overline{CE} \cong \overline{EA}$
- 4) $\overline{CF} \cong \overline{FA}$

Geometry Multiple Choice Regents Exam Questions

www.jmap.org

- 54 What is the negation of the statement “Squares are parallelograms”?
- 1) Parallelograms are squares.
 - 2) Parallelograms are not squares.
 - 3) It is not the case that squares are parallelograms.
 - 4) It is not the case that parallelograms are squares.
- 55 A transversal intersects two lines. Which condition would always make the two lines parallel?
- 1) Vertical angles are congruent.
 - 2) Alternate interior angles are congruent.
 - 3) Corresponding angles are supplementary.
 - 4) Same-side interior angles are complementary.
- 56 What are the center and radius of a circle whose equation is $(x - A)^2 + (y - B)^2 = C$?
- 1) center = (A, B) ; radius = C
 - 2) center = $(-A, -B)$; radius = C
 - 3) center = (A, B) ; radius = \sqrt{C}
 - 4) center = $(-A, -B)$; radius = \sqrt{C}
- 57 Line k is drawn so that it is perpendicular to two distinct planes, P and R . What must be true about planes P and R ?
- 1) Planes P and R are skew.
 - 2) Planes P and R are parallel.
 - 3) Planes P and R are perpendicular.
 - 4) Plane P intersects plane R but is not perpendicular to plane R .
- 58 What is the slope of a line perpendicular to the line whose equation is $y = 3x + 4$?
- 1) $\frac{1}{3}$
 - 2) $-\frac{1}{3}$
 - 3) 3
 - 4) -3

- 59 What is the slope of a line that is perpendicular to the line whose equation is $3x + 4y = 12$?
- 1) $\frac{3}{4}$
 - 2) $-\frac{3}{4}$
 - 3) $\frac{4}{3}$
 - 4) $-\frac{4}{3}$
- 60 On the set of axes below, Geoff drew rectangle $ABCD$. He will transform the rectangle by using the translation $(x, y) \rightarrow (x + 2, y + 1)$ and then will reflect the translated rectangle over the x -axis.

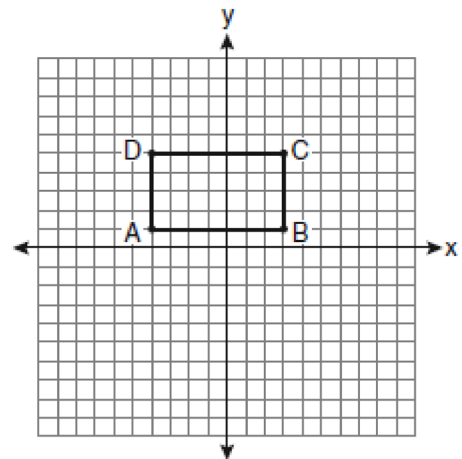

What will be the area of the rectangle after these transformations?

- 1) exactly 28 square units
 - 2) less than 28 square units
 - 3) greater than 28 square units
 - 4) It cannot be determined from the information given.
- 61 The endpoints of \overline{AB} are $A(3, 2)$ and $B(7, 1)$. If $\overline{A''B''}$ is the result of the transformation of \overline{AB} under $D_2 \circ T_{-4, 3}$ what are the coordinates of A'' and B'' ?
- 1) $A''(-2, 10)$ and $B''(6, 8)$
 - 2) $A''(-1, 5)$ and $B''(3, 4)$
 - 3) $A''(2, 7)$ and $B''(10, 5)$
 - 4) $A''(14, -2)$ and $B''(22, -4)$

- 62 Which equation represents circle K shown in the graph below?

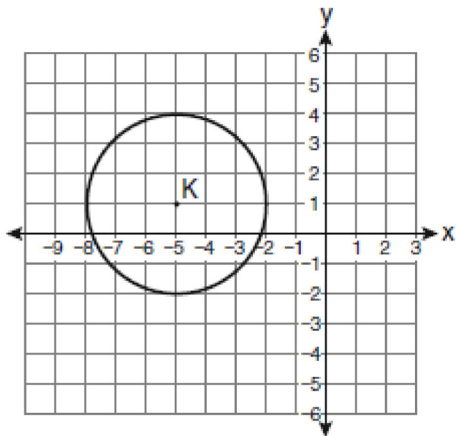

- 1) $(x + 5)^2 + (y - 1)^2 = 3$
 - 2) $(x + 5)^2 + (y - 1)^2 = 9$
 - 3) $(x - 5)^2 + (y + 1)^2 = 3$
 - 4) $(x - 5)^2 + (y + 1)^2 = 9$
- 63 What is an equation of a circle with its center at $(-3, 5)$ and a radius of 4?
- 1) $(x - 3)^2 + (y + 5)^2 = 16$
 - 2) $(x + 3)^2 + (y - 5)^2 = 16$
 - 3) $(x - 3)^2 + (y + 5)^2 = 4$
 - 4) $(x + 3)^2 + (y - 5)^2 = 4$
- 64 What is the slope of a line perpendicular to the line whose equation is $5x + 3y = 8$?
- 1) $\frac{5}{3}$
 - 2) $\frac{3}{5}$
 - 3) $-\frac{3}{5}$
 - 4) $-\frac{5}{3}$

- 65 Triangle ABC has vertices $A(1, 3)$, $B(0, 1)$, and $C(4, 0)$. Under a translation, A' , the image point of A , is located at $(4, 4)$. Under this same translation, point C' is located at
- 1) $(7, 1)$
 - 2) $(5, 3)$
 - 3) $(3, 2)$
 - 4) $(1, -1)$
- 66 What is the distance between the points $(-3, 2)$ and $(1, 0)$?
- 1) $2\sqrt{2}$
 - 2) $2\sqrt{3}$
 - 3) $5\sqrt{2}$
 - 4) $2\sqrt{5}$
- 67 A support beam between the floor and ceiling of a house forms a 90° angle with the floor. The builder wants to make sure that the floor and ceiling are parallel. Which angle should the support beam form with the ceiling?
- 1) 45°
 - 2) 60°
 - 3) 90°
 - 4) 180°
- 68 The diagonal \overline{AC} is drawn in parallelogram $ABCD$. Which method can *not* be used to prove that $\triangle ABC \cong \triangle CDA$?
- 1) SSS
 - 2) SAS
 - 3) SSA
 - 4) ASA

Geometry Multiple Choice Regents Exam Questions

www.jmap.org

- 69 In the diagram below of $\triangle AGE$ and $\triangle OLD$, $\angle GAE \cong \angle LOD$, and $\overline{AE} \cong \overline{OD}$.

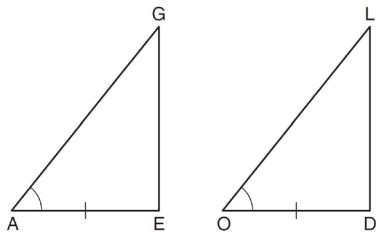

To prove that $\triangle AGE$ and $\triangle OLD$ are congruent by SAS, what other information is needed?

- 1) $\overline{GE} \cong \overline{LD}$
 - 2) $\overline{AG} \cong \overline{OL}$
 - 3) $\angle AGE \cong \angle OLD$
 - 4) $\angle AEG \cong \angle ODL$
- 70 In the diagram of $\triangle ABC$ below, $\overline{AB} \cong \overline{AC}$. The measure of $\angle B$ is 40° .

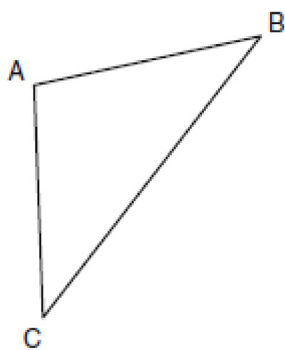

What is the measure of $\angle A$?

- 71 Based on the diagram below, which statement is true?

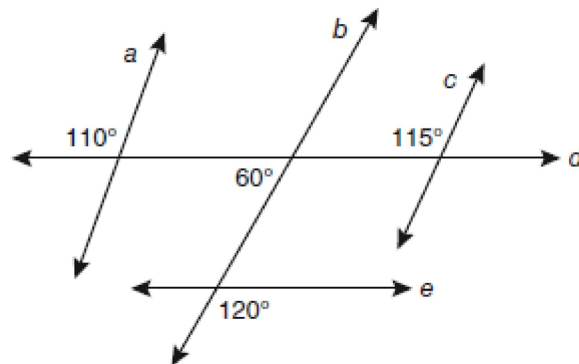

- 1) $a \parallel b$
 - 2) $a \parallel c$
 - 3) $b \parallel c$
 - 4) $d \parallel e$
- 72 Which equation represents a line parallel to the line whose equation is $2y - 5x = 10$?
- 1) $5y - 2x = 25$
 - 2) $5y + 2x = 10$
 - 3) $4y - 10x = 12$
 - 4) $2y + 10x = 8$
- 73 Given the system of equations: $y = x^2 - 4x$
 $x = 4$
- The number of points of intersection is
- 1) 1
 - 2) 2
 - 3) 3
 - 4) 0
- 74 The coordinates of the vertices of parallelogram $ABCD$ are $A(-3,2)$, $B(-2,-1)$, $C(4,1)$, and $D(3,4)$. The slopes of which line segments could be calculated to show that $ABCD$ is a rectangle?
- 1) \overline{AB} and \overline{DC}
 - 2) \overline{AB} and \overline{BC}
 - 3) \overline{AD} and \overline{BC}
 - 4) \overline{AC} and \overline{BD}

- 75 What is the negation of the statement “I am not going to eat ice cream”?
- 1) I like ice cream.
 - 2) I am going to eat ice cream.
 - 3) If I eat ice cream, then I like ice cream.
 - 4) If I don't like ice cream, then I don't eat ice cream.
- 76 The lines represented by the equations $y + \frac{1}{2}x = 4$ and $3x + 6y = 12$ are
- 1) the same line
 - 2) parallel
 - 3) perpendicular
 - 4) neither parallel nor perpendicular
- 77 The diagram below shows \overline{AB} and \overline{DE} .

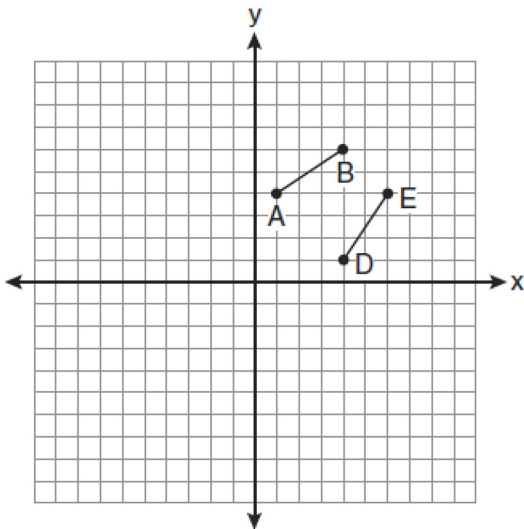

Which transformation will move \overline{AB} onto \overline{DE} such that point D is the image of point A and point E is the image of point B ?

- 1) $T_{3,-3}$
- 2) $D_{\frac{1}{2}}$
- 3) R_{90°
- 4) $r_{y=x}$

- 78 Square $LMNO$ is shown in the diagram below.

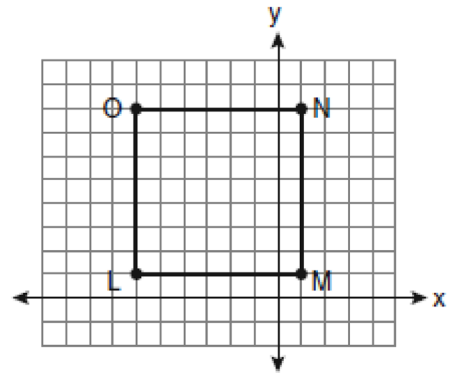

What are the coordinates of the midpoint of diagonal \overline{LN} ?

- 1) $(4\frac{1}{2}, -2\frac{1}{2})$
 - 2) $(-3\frac{1}{2}, 3\frac{1}{2})$
 - 3) $(-2\frac{1}{2}, 3\frac{1}{2})$
 - 4) $(-2\frac{1}{2}, 4\frac{1}{2})$
- 79 In which triangle do the three altitudes intersect outside the triangle?
- 1) a right triangle
 - 2) an acute triangle
 - 3) an obtuse triangle
 - 4) an equilateral triangle
- 80 If two different lines are perpendicular to the same plane, they are
- 1) collinear
 - 2) coplanar
 - 3) congruent
 - 4) consecutive
- 81 A rectangular prism has a volume of $3x^2 + 18x + 24$. Its base has a length of $x + 2$ and a width of 3. Which expression represents the height of the prism?
- 1) $x + 4$
 - 2) $x + 2$
 - 3) 3
 - 4) $x^2 + 6x + 8$

- 82 The vertices of $\triangle ABC$ are $A(-1,-2)$, $B(-1,2)$ and $C(6,0)$. Which conclusion can be made about the angles of $\triangle ABC$?
- 1) $m\angle A = m\angle B$
 - 2) $m\angle A = m\angle C$
 - 3) $m\angle ACB = 90$
 - 4) $m\angle ABC = 60$

- 83 In the diagram below, which transformation was used to map $\triangle ABC$ to $\triangle A'B'C'$?

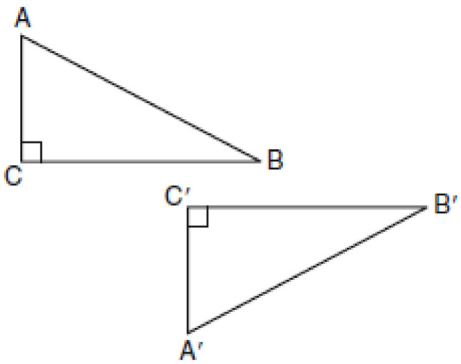

- 1) dilation
 - 2) rotation
 - 3) reflection
 - 4) glide reflection
- 84 In which polygon does the sum of the measures of the interior angles equal the sum of the measures of the exterior angles?
- 1) triangle
 - 2) hexagon
 - 3) octagon
 - 4) quadrilateral
- 85 Line segment AB is tangent to circle O at A . Which type of triangle is always formed when points A , B , and O are connected?
- 1) right
 - 2) obtuse
 - 3) scalene
 - 4) isosceles

- 86 In the diagram below of $\triangle ABC$, medians \overline{AD} , \overline{BE} , and \overline{CF} intersect at G .

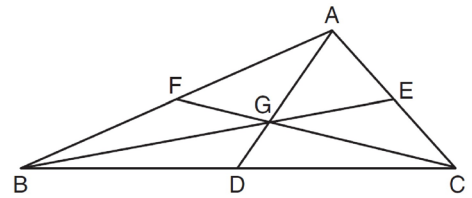

If $CF = 24$, what is the length of \overline{FG} ?

- 1) 8
- 2) 10
- 3) 12
- 4) 16

- 87 Which graph represents a circle with the equation $(x-5)^2 + (y+1)^2 = 9$?

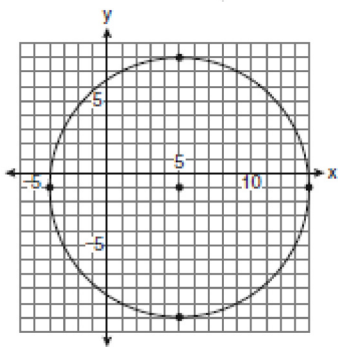
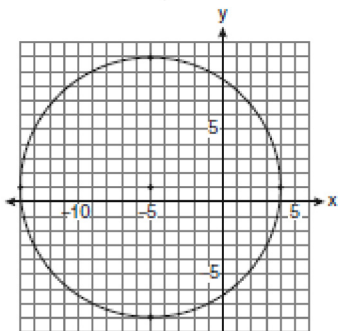
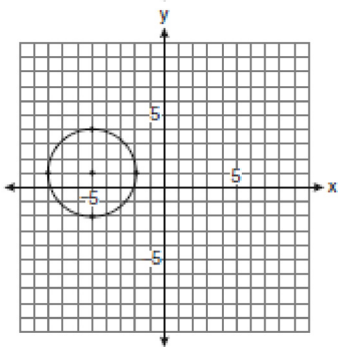
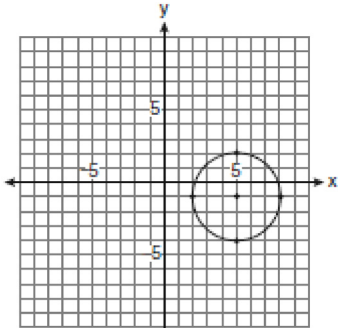

- 88 Juliann plans on drawing $\triangle ABC$, where the measure of $\angle A$ can range from 50° to 60° and the measure of $\angle B$ can range from 90° to 100° . Given these conditions, what is the correct range of measures possible for $\angle C$?
- 1) 20° to 40°
 - 2) 30° to 50°
 - 3) 80° to 90°
 - 4) 120° to 130°

- 89 In the diagram below of $\triangle ACT$, $\overleftrightarrow{BE} \parallel \overline{AT}$.

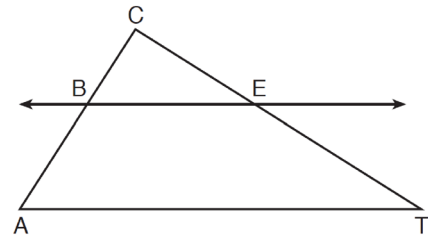

If $CB = 3$, $CA = 10$, and $CE = 6$, what is the length of \overline{ET} ?

- 1) 5
 - 2) 14
 - 3) 20
 - 4) 26
- 90 What is the length of the line segment with endpoints $(-6, 4)$ and $(2, -5)$?
- 1) $\sqrt{13}$
 - 2) $\sqrt{17}$
 - 3) $\sqrt{72}$
 - 4) $\sqrt{145}$

- 91 In the diagram below of circle O , secant \overline{AB} intersects circle O at D , secant \overline{AOC} intersects circle O at E , $AE = 4$, $AB = 12$, and $DB = 6$.

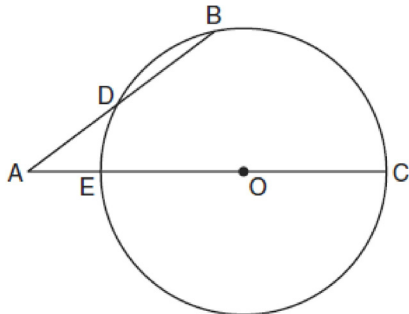

(Not drawn to scale)

- What is the length of \overline{OC} ?
- 1) 4.5
 - 2) 7
 - 3) 9
 - 4) 14
- 92 If $\triangle ABC \sim \triangle ZXY$, $m\angle A = 50$, and $m\angle C = 30$, what is $m\angle X$?
- 1) 30
 - 2) 50
 - 3) 80
 - 4) 100
- 93 What is the inverse of the statement “If two triangles are not similar, their corresponding angles are not congruent”?
- 1) If two triangles are similar, their corresponding angles are not congruent.
 - 2) If corresponding angles of two triangles are not congruent, the triangles are not similar.
 - 3) If two triangles are similar, their corresponding angles are congruent.
 - 4) If corresponding angles of two triangles are congruent, the triangles are similar.
- 94 What is the contrapositive of the statement, “If I am tall, then I will bump my head”?
- 1) If I bump my head, then I am tall.
 - 2) If I do not bump my head, then I am tall.
 - 3) If I am tall, then I will not bump my head.
 - 4) If I do not bump my head, then I am not tall.

- 95 In the diagram below, \overline{PS} is a tangent to circle O at point S , \overline{PQR} is a secant, $PS = x$, $PQ = 3$, and $PR = x + 18$.

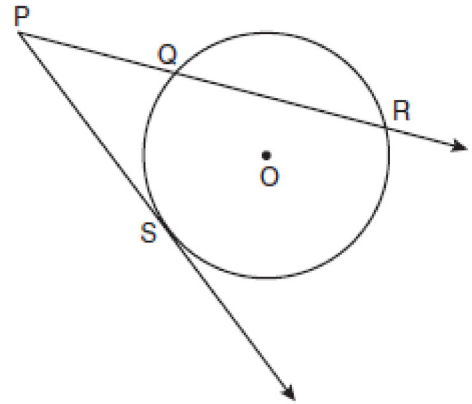

(Not drawn to scale)

- What is the length of \overline{PS} ?
- 1) 6
 - 2) 9
 - 3) 3
 - 4) 27
- 96 What is the equation of a line that is parallel to the line whose equation is $y = x + 2$?
- 1) $x + y = 5$
 - 2) $2x + y = -2$
 - 3) $y - x = -1$
 - 4) $y - 2x = 3$

- 97 In the diagram below of circle O , chords \overline{AD} and \overline{BC} intersect at E , $m\widehat{AC} = 87$, and $m\widehat{BD} = 35$.

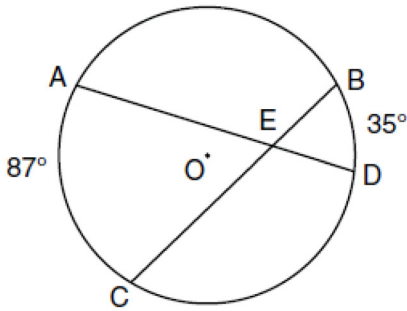

What is the degree measure of $\angle CEA$?

- 1) 87
 - 2) 61
 - 3) 43.5
 - 4) 26
- 98 Two lines are represented by the equations $-\frac{1}{2}y = 6x + 10$ and $y = mx$. For which value of m will the lines be parallel?
- 1) -12
 - 2) -3
 - 3) 3
 - 4) 12
- 99 How many common tangent lines can be drawn to the two externally tangent circles shown below?

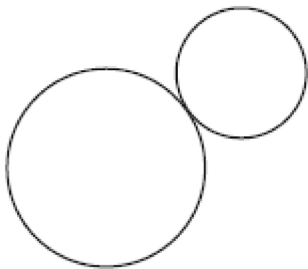

- 1) 1
- 2) 2
- 3) 3
- 4) 4

- 100 In the diagram below, the length of the legs \overline{AC} and \overline{BC} of right triangle ABC are 6 cm and 8 cm, respectively. Altitude \overline{CD} is drawn to the hypotenuse of $\triangle ABC$.

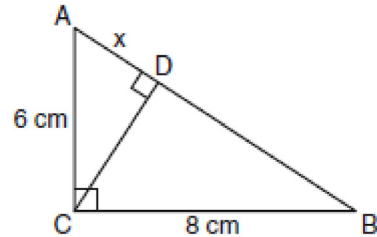

What is the length of \overline{AD} to the nearest tenth of a centimeter?

- 1) 3.6
 - 2) 6.0
 - 3) 6.4
 - 4) 4.0
- 101 In the diagram below, the vertices of $\triangle DEF$ are the midpoints of the sides of equilateral triangle ABC , and the perimeter of $\triangle ABC$ is 36 cm.

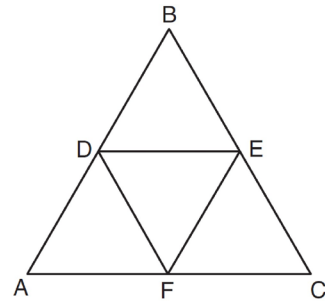

What is the length, in centimeters, of \overline{EF} ?

- 1) 6
- 2) 12
- 3) 18
- 4) 4

- 102 What is the solution of the following system of equations?

$$y = (x + 3)^2 - 4$$

$$y = 2x + 5$$

- 1) $(0, -4)$
 - 2) $(-4, 0)$
 - 3) $(-4, -3)$ and $(0, 5)$
 - 4) $(-3, -4)$ and $(5, 0)$
- 103 Through a given point, P , on a plane, how many lines can be drawn that are perpendicular to that plane?
- 1) 1
 - 2) 2
 - 3) more than 2
 - 4) none
- 104 The endpoints of \overline{CD} are $C(-2, -4)$ and $D(6, 2)$. What are the coordinates of the midpoint of \overline{CD} ?
- 1) $(2, 3)$
 - 2) $(2, -1)$
 - 3) $(4, -2)$
 - 4) $(4, 3)$
- 105 In isosceles trapezoid $ABCD$, $\overline{AB} \cong \overline{CD}$. If $BC = 20$, $AD = 36$, and $AB = 17$, what is the length of the altitude of the trapezoid?
- 1) 10
 - 2) 12
 - 3) 15
 - 4) 16
- 106 In $\triangle ABC$, $m\angle A = x$, $m\angle B = 2x + 2$, and $m\angle C = 3x + 4$. What is the value of x ?
- 1) 29
 - 2) 31
 - 3) 59
 - 4) 61

- 107 In the diagram below, circle A and circle B are shown.

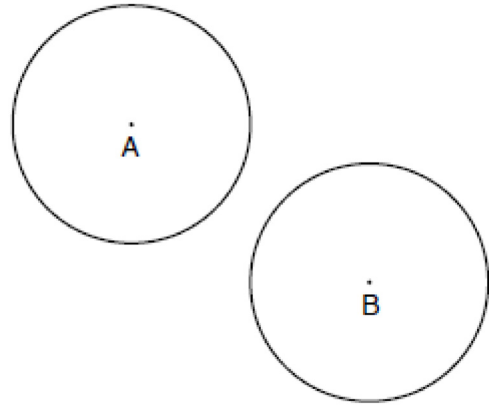

What is the total number of lines of tangency that are common to circle A and circle B ?

- 1) 1
 - 2) 2
 - 3) 3
 - 4) 4
- 108 A right circular cylinder has a volume of 1,000 cubic inches and a height of 8 inches. What is the radius of the cylinder to the *nearest tenth of an inch*?
- 1) 6.3
 - 2) 11.2
 - 3) 19.8
 - 4) 39.8
- 109 A polygon is transformed according to the rule: $(x, y) \rightarrow (x + 2, y)$. Every point of the polygon moves two units in which direction?
- 1) up
 - 2) down
 - 3) left
 - 4) right
- 110 Point P is on line m . What is the total number of planes that are perpendicular to line m and pass through point P ?
- 1) 1
 - 2) 2
 - 3) 0
 - 4) infinite

- 111 In the diagram below of parallelogram $STUV$, $SV = x + 3$, $VU = 2x - 1$, and $TU = 4x - 3$.

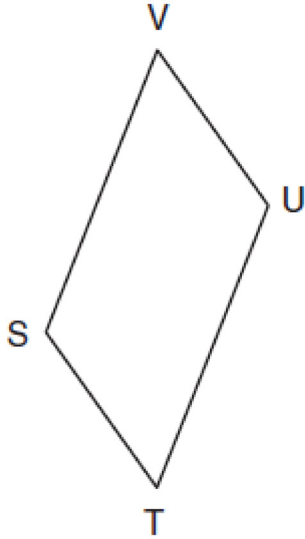

What is the length of \overline{SV} ?

- 1) 5
 - 2) 2
 - 3) 7
 - 4) 4
- 112 Towns A and B are 16 miles apart. How many points are 10 miles from town A and 12 miles from town B ?
- 1) 1
 - 2) 2
 - 3) 3
 - 4) 0

- 113 In the diagram below of circle O , chord $\overline{AB} \parallel$ chord \overline{CD} , and chord $\overline{CD} \parallel$ chord \overline{EF} .

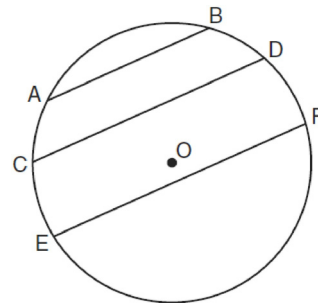

Which statement must be true?

- 1) $\widehat{CE} \cong \widehat{DF}$
 - 2) $\widehat{AC} \cong \widehat{DF}$
 - 3) $\widehat{AC} \cong \widehat{CE}$
 - 4) $\widehat{EF} \cong \widehat{CD}$
- 114 In the diagram below of circle O , chords \overline{AB} and \overline{CD} intersect at E .

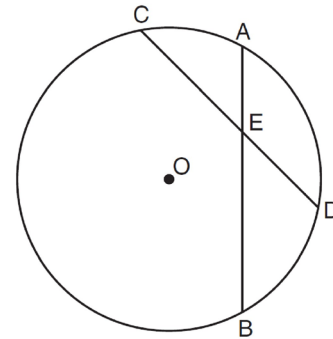

If $\overline{CE} = 10$, $\overline{ED} = 6$, and $\overline{AE} = 4$, what is the length of \overline{EB} ?

- 1) 15
- 2) 12
- 3) 6.7
- 4) 2.4

115 What is an equation of the line that contains the point $(3, -1)$ and is perpendicular to the line whose equation is $y = -3x + 2$?

- 1) $y = -3x + 8$
- 2) $y = -3x$
- 3) $y = \frac{1}{3}x$
- 4) $y = \frac{1}{3}x - 2$

116 Given: $y = \frac{1}{4}x - 3$

$$y = x^2 + 8x + 12$$

In which quadrant will the graphs of the given equations intersect?

- 1) I
- 2) II
- 3) III
- 4) IV

117 The diagram below illustrates the construction of \overleftrightarrow{PS} parallel to \overleftrightarrow{RQ} through point P .

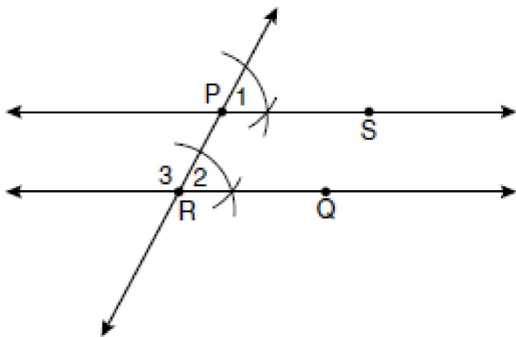

Which statement justifies this construction?

- 1) $m\angle 1 = m\angle 2$
- 2) $m\angle 1 = m\angle 3$
- 3) $\overline{PR} \cong \overline{RQ}$
- 4) $\overline{PS} \cong \overline{RQ}$

118 What is an equation for the circle shown in the graph below?

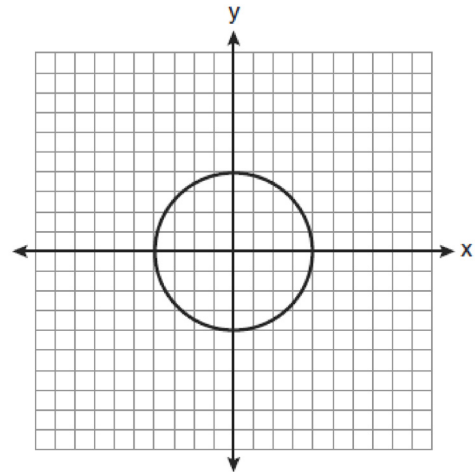

- 1) $x^2 + y^2 = 2$
- 2) $x^2 + y^2 = 4$
- 3) $x^2 + y^2 = 8$
- 4) $x^2 + y^2 = 16$

119 In $\triangle ABC$, $AB = 7$, $BC = 8$, and $AC = 9$. Which list has the angles of $\triangle ABC$ in order from smallest to largest?

- 1) $\angle A, \angle B, \angle C$
- 2) $\angle B, \angle A, \angle C$
- 3) $\angle C, \angle B, \angle A$
- 4) $\angle C, \angle A, \angle B$

120 The lines $3y + 1 = 6x + 4$ and $2y + 1 = x - 9$ are

- 1) parallel
- 2) perpendicular
- 3) the same line
- 4) neither parallel nor perpendicular

121 The diameter of a circle has endpoints at $(-2, 3)$ and $(6, 3)$. What is an equation of the circle?

- 1) $(x - 2)^2 + (y - 3)^2 = 16$
- 2) $(x - 2)^2 + (y - 3)^2 = 4$
- 3) $(x + 2)^2 + (y + 3)^2 = 16$
- 4) $(x + 2)^2 + (y + 3)^2 = 4$

- 122 Which illustration shows the correct construction of an angle bisector?

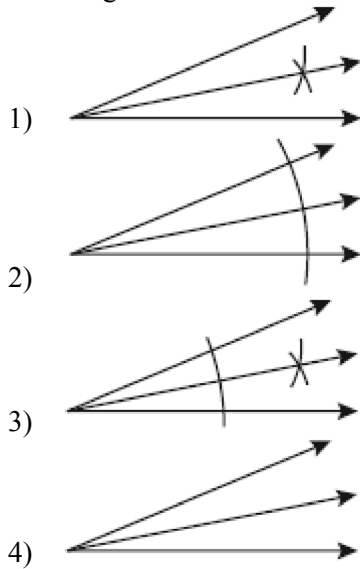

- 123 In the diagram below of regular pentagon $ABCDE$, \overline{EB} is drawn.

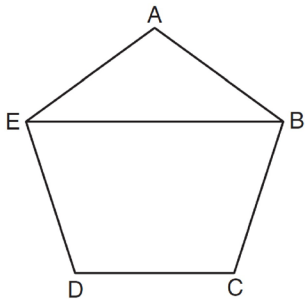

What is the measure of $\angle AEB$?

- 1) 36°
 2) 54°
 3) 72°
 4) 108°
- 124 In an equilateral triangle, what is the difference between the sum of the exterior angles and the sum of the interior angles?
- 1) 180°
 2) 120°
 3) 90°
 4) 60°

- 125 In the diagram of circle O below, chord \overline{CD} is parallel to diameter \overline{AOB} and $m\widehat{AC} = 30$.

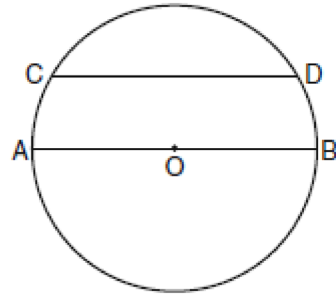

What is $m\widehat{CD}$?

- 1) 150
 2) 120
 3) 100
 4) 60
- 126 A right circular cylinder has an altitude of 11 feet and a radius of 5 feet. What is the lateral area, in square feet, of the cylinder, to the nearest tenth?
- 1) 172.7
 2) 172.8
 3) 345.4
 4) 345.6
- 127 What is the measure of an interior angle of a regular octagon?
- 1) 45°
 2) 60°
 3) 120°
 4) 135°
- 128 What is the negation of the statement "The Sun is shining"?
- 1) It is cloudy.
 2) It is daytime.
 3) It is not raining.
 4) The Sun is not shining.

- 129 What is the converse of the statement "If Bob does his homework, then George gets candy"?
- 1) If George gets candy, then Bob does his homework.
 - 2) Bob does his homework if and only if George gets candy.
 - 3) If George does not get candy, then Bob does not do his homework.
 - 4) If Bob does not do his homework, then George does not get candy.

- 130 Line segment AB has endpoints $A(2, -3)$ and $B(-4, 6)$. What are the coordinates of the midpoint of AB ?
- 1) $(-2, 3)$
 - 2) $\left(-1, 1\frac{1}{2}\right)$
 - 3) $(-1, 3)$
 - 4) $\left(3, 4\frac{1}{2}\right)$

- 131 In the diagram below of circle O , chords \overline{AE} and \overline{DC} intersect at point B , such that $m\widehat{AC} = 36$ and $m\widehat{DE} = 20$.

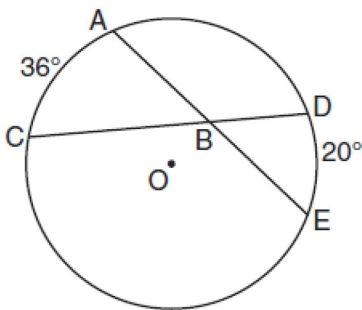

What is $m\angle ABC$?

- 1) 56
- 2) 36
- 3) 28
- 4) 8

- 132 In the diagram of circle O below, chord \overline{AB} intersects chord \overline{CD} at E , $DE = 2x + 8$, $EC = 3$, $AE = 4x - 3$, and $EB = 4$.

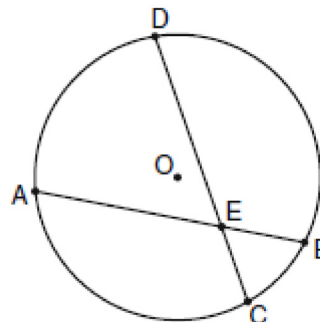

What is the value of x ?

- 1) 1
 - 2) 3.6
 - 3) 5
 - 4) 10.25
- 133 In a coordinate plane, how many points are both 5 units from the origin and 2 units from the x -axis?
- 1) 1
 - 2) 2
 - 3) 3
 - 4) 4
- 134 Point A is located at $(4, -7)$. The point is reflected in the x -axis. Its image is located at
- 1) $(-4, 7)$
 - 2) $(-4, -7)$
 - 3) $(4, 7)$
 - 4) $(7, -4)$

- 135 In the diagram of $\triangle ABC$ below, Jose found centroid P by constructing the three medians. He measured \overline{CF} and found it to be 6 inches.

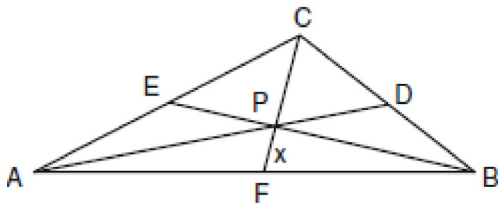

If $PF = x$, which equation can be used to find x ?

- 1) $x + x = 6$
 - 2) $2x + x = 6$
 - 3) $3x + 2x = 6$
 - 4) $x + \frac{2}{3}x = 6$
- 136 In the diagram of trapezoid $ABCD$ below, diagonals \overline{AC} and \overline{BD} intersect at E and $\triangle ABC \cong \triangle DCB$.

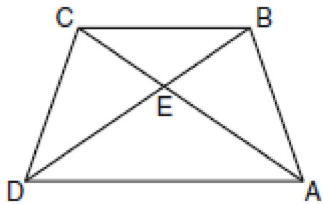

Which statement is true based on the given information?

- 1) $\overline{AC} \cong \overline{BC}$
- 2) $\overline{CD} \cong \overline{AD}$
- 3) $\angle CDE \cong \angle BAD$
- 4) $\angle CDB \cong \angle BAC$

- 137 In the diagram below, line k is perpendicular to plane \mathcal{P} at point T .

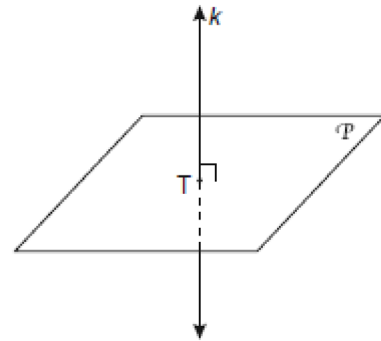

Which statement is true?

- 1) Any point in plane \mathcal{P} also will be on line k .
- 2) Only one line in plane \mathcal{P} will intersect line k .
- 3) All planes that intersect plane \mathcal{P} will pass through T .
- 4) Any plane containing line k is perpendicular to plane \mathcal{P} .

- 138 In the diagram below, \overline{SQ} and \overline{PR} intersect at T , \overline{PQ} is drawn, and $\overline{PS} \parallel \overline{QR}$.

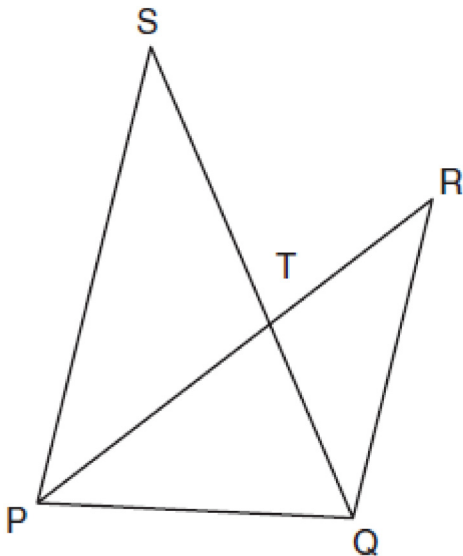

What technique can be used to prove that $\triangle PST \sim \triangle RQT$?

- 1) SAS
 - 2) SSS
 - 3) ASA
 - 4) AA
- 139 What is the slope of a line perpendicular to the line whose equation is $y = -\frac{2}{3}x - 5$?
- 1) $-\frac{3}{2}$
 - 2) $-\frac{2}{3}$
 - 3) $\frac{2}{3}$
 - 4) $\frac{3}{2}$
- 140 Two triangles are similar, and the ratio of each pair of corresponding sides is 2:1. Which statement regarding the two triangles is *not* true?
- 1) Their areas have a ratio of 4:1.
 - 2) Their altitudes have a ratio of 2:1.
 - 3) Their perimeters have a ratio of 2:1.
 - 4) Their corresponding angles have a ratio of 2:1.

- 141 In $\triangle ABC$, $\overline{AB} \cong \overline{BC}$. An altitude is drawn from B to \overline{AC} and intersects \overline{AC} at D . Which conclusion is *not* always true?

- 1) $\angle ABD \cong \angle CBD$
- 2) $\angle BDA \cong \angle BDC$
- 3) $\overline{AD} \cong \overline{BD}$
- 4) $\overline{AD} \cong \overline{DC}$

- 142 Side \overline{PQ} of $\triangle PQR$ is extended through Q to point T . Which statement is *not* always true?

- 1) $m\angle RQT > m\angle R$
- 2) $m\angle RQT > m\angle P$
- 3) $m\angle RQT = m\angle P + m\angle R$
- 4) $m\angle RQT > m\angle PQR$

- 143 The figure in the diagram below is a triangular prism.

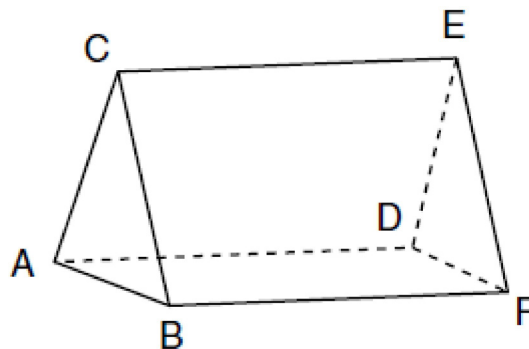

Which statement must be true?

- 1) $\overline{DE} \cong \overline{AB}$
- 2) $\overline{AD} \cong \overline{BC}$
- 3) $\overline{AD} \parallel \overline{CE}$
- 4) $\overline{DE} \parallel \overline{BC}$

Geometry Multiple Choice Regents Exam Questions

www.jmap.org

- 144 In the diagram below, a right circular cone has a diameter of 8 inches and a height of 12 inches.

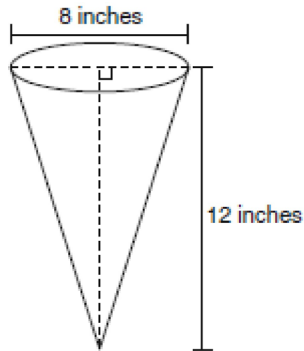

What is the volume of the cone to the *nearest cubic inch*?

- 1) 201
 - 2) 481
 - 3) 603
 - 4) 804
- 145 Which equation represents a line perpendicular to the line whose equation is $2x + 3y = 12$?
- 1) $6y = -4x + 12$
 - 2) $2y = 3x + 6$
 - 3) $2y = -3x + 6$
 - 4) $3y = -2x + 12$
- 146 In the diagram below of right triangle ACB , altitude \overline{CD} is drawn to hypotenuse \overline{AB} .

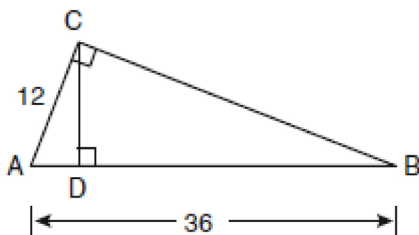

If $AB = 36$ and $AC = 12$, what is the length of \overline{AD} ?

- 1) 32
- 2) 6
- 3) 3
- 4) 4

- 147 Given the equations: $y = x^2 - 6x + 10$

$$y + x = 4$$

What is the solution to the given system of equations?

- 1) (2,3)
 - 2) (3,2)
 - 3) (2,2) and (1,3)
 - 4) (2,2) and (3,1)
- 148 One step in a construction uses the endpoints of \overline{AB} to create arcs with the same radii. The arcs intersect above and below the segment. What is the relationship of \overline{AB} and the line connecting the points of intersection of these arcs?
- 1) collinear
 - 2) congruent
 - 3) parallel
 - 4) perpendicular
- 149 Which expression represents the volume, in cubic centimeters, of the cylinder represented in the diagram below?

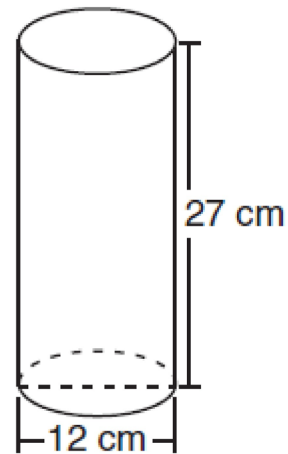

- 1) 162π
- 2) 324π
- 3) 972π
- 4) $3,888\pi$

- 150 Which diagram shows the construction of an equilateral triangle?

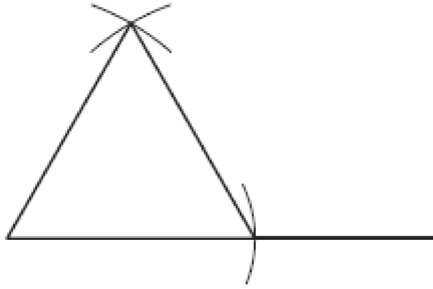

1)

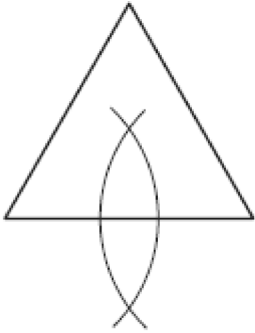

2)

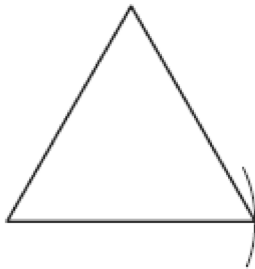

3)

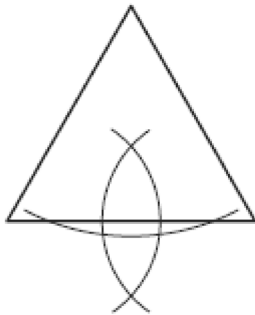

4)

- 151 In the diagram below, $\triangle ABC$ is shown with \overline{AC} extended through point D .

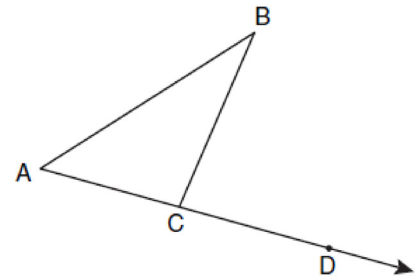

If $m\angle BCD = 6x + 2$, $m\angle BAC = 3x + 15$, and $m\angle ABC = 2x - 1$, what is the value of x ?

- 1) 12
 - 2) $14\frac{10}{11}$
 - 3) 16
 - 4) $18\frac{1}{9}$
- 152 In the diagram of circle O below, chords \overline{AB} and \overline{CD} are parallel, and \overline{BD} is a diameter of the circle.

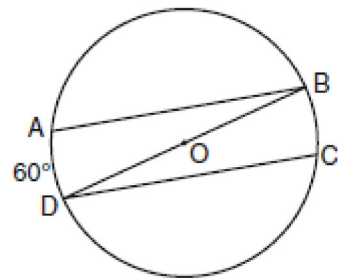

If $m\widehat{AD} = 60$, what is $m\angle CDB$?

- 1) 20
 - 2) 30
 - 3) 60
 - 4) 120
- 153 What is the image of point $A(4,2)$ after the composition of transformations defined by $R_{90^\circ} \circ r_{y=x}$?
- 1) $(-4,2)$
 - 2) $(4,-2)$
 - 3) $(-4,-2)$
 - 4) $(2,-4)$

- 154 A quadrilateral whose diagonals bisect each other and are perpendicular is a
- 1) rhombus
 - 2) rectangle
 - 3) trapezoid
 - 4) parallelogram

- 155 The equation of a circle is $(x - 2)^2 + (y + 4)^2 = 4$. Which diagram is the graph of the circle?

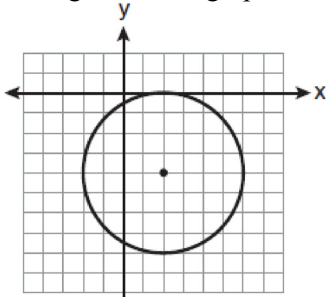

1)

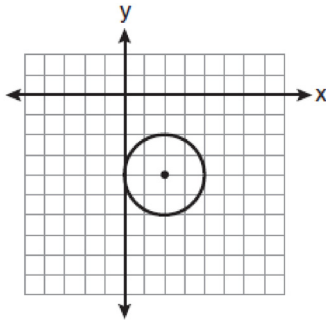

2)

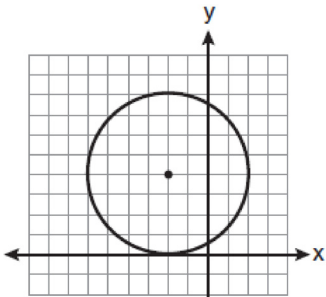

3)

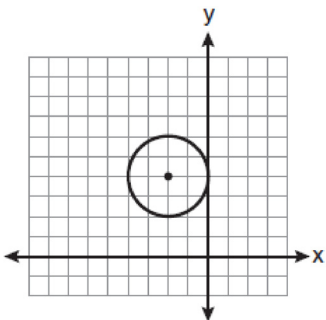

4)

- 156 In the diagram below of $\triangle ABC$, \overline{CD} is the bisector of $\angle BCA$, \overline{AE} is the bisector of $\angle CAB$, and \overline{BG} is drawn.

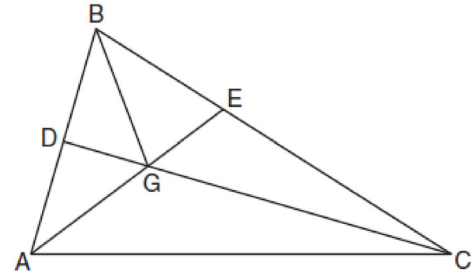

Which statement must be true?

- 1) $DG = EG$
 - 2) $AG = BG$
 - 3) $\angle AEB \cong \angle AEC$
 - 4) $\angle DBG \cong \angle EBG$
- 157 In the diagram below, circle O has a radius of 5, and $CE = 2$. Diameter \overline{AC} is perpendicular to chord \overline{BD} at E .

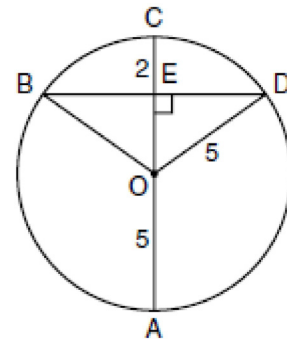

What is the length of \overline{BD} ?

- 1) 12
- 2) 10
- 3) 8
- 4) 4

- 158 The diagram below shows the construction of the center of the circle circumscribed about $\triangle ABC$.

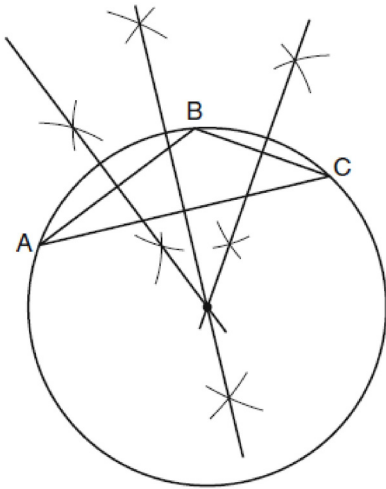

This construction represents how to find the intersection of

- 1) the angle bisectors of $\triangle ABC$
 - 2) the medians to the sides of $\triangle ABC$
 - 3) the altitudes to the sides of $\triangle ABC$
 - 4) the perpendicular bisectors of the sides of $\triangle ABC$
- 159 If the endpoints of \overline{AB} are $A(-4,5)$ and $B(2,-5)$, what is the length of \overline{AB} ?
- 1) $2\sqrt{34}$
 - 2) 2
 - 3) $\sqrt{61}$
 - 4) 8
- 160 What are the center and the radius of the circle whose equation is $(x-3)^2 + (y+3)^2 = 36$
- 1) center = $(3,-3)$; radius = 6
 - 2) center = $(-3,3)$; radius = 6
 - 3) center = $(3,-3)$; radius = 36
 - 4) center = $(-3,3)$; radius = 36

- 161 In the diagram below of circle O , chords \overline{AD} and \overline{BC} intersect at E .

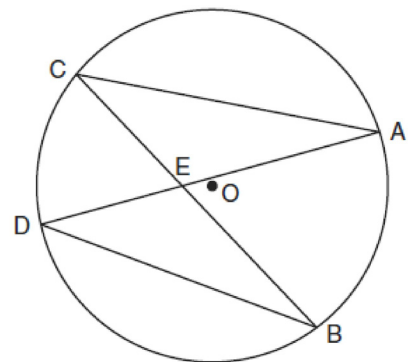

Which relationship must be true?

- 1) $\triangle CAE \cong \triangle DBE$
 - 2) $\triangle AEC \sim \triangle BED$
 - 3) $\angle ACB \cong \angle CBD$
 - 4) $\widehat{CA} \cong \widehat{DB}$
- 162 Which geometric principle is used to justify the construction below?

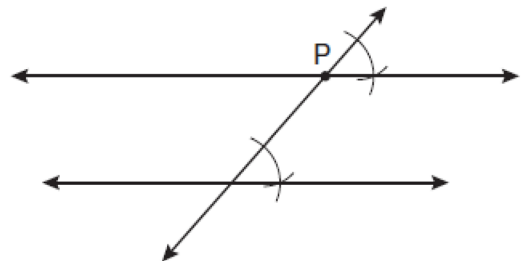

- 1) A line perpendicular to one of two parallel lines is perpendicular to the other.
- 2) Two lines are perpendicular if they intersect to form congruent adjacent angles.
- 3) When two lines are intersected by a transversal and alternate interior angles are congruent, the lines are parallel.
- 4) When two lines are intersected by a transversal and the corresponding angles are congruent, the lines are parallel.

- 163 In plane \mathcal{P} , lines m and n intersect at point A . If line k is perpendicular to line m and line n at point A , then line k is
- 1) contained in plane \mathcal{P}
 - 2) parallel to plane \mathcal{P}
 - 3) perpendicular to plane \mathcal{P}
 - 4) skew to plane \mathcal{P}

- 164 In $\triangle ABC$, $m\angle A = 95$, $m\angle B = 50$, and $m\angle C = 35$. Which expression correctly relates the lengths of the sides of this triangle?
- 1) $AB < BC < CA$
 - 2) $AB < AC < BC$
 - 3) $AC < BC < AB$
 - 4) $BC < AC < AB$

- 165 The diagram below shows the construction of the bisector of $\angle ABC$.

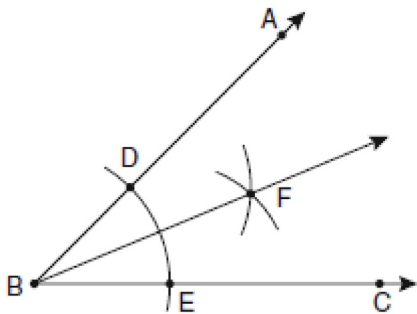

Which statement is *not* true?

- 1) $m\angle EBF = \frac{1}{2} m\angle ABC$
- 2) $m\angle DBF = \frac{1}{2} m\angle ABC$
- 3) $m\angle EBF = m\angle ABC$
- 4) $m\angle DBF = m\angle EBF$

- 166 The pentagon in the diagram below is formed by five rays.

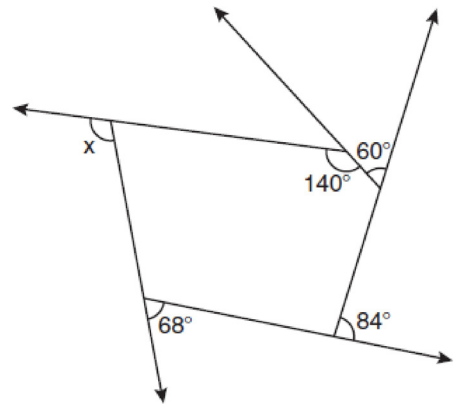

What is the degree measure of angle x ?

- 1) 72
 - 2) 96
 - 3) 108
 - 4) 112
- 167 What is the length, to the *nearest tenth*, of the line segment joining the points $(-4, 2)$ and $(146, 52)$?
- 1) 141.4
 - 2) 150.5
 - 3) 151.9
 - 4) 158.1
- 168 The lateral faces of a regular pyramid are composed of
- 1) squares
 - 2) rectangles
 - 3) congruent right triangles
 - 4) congruent isosceles triangles

Geometry 2 Point Regents Exam Questions

1 Write an equation of the line that passes through the point $(6, -5)$ and is parallel to the line whose equation is $2x - 3y = 11$.

2 In the diagram below, $\triangle ABC \sim \triangle EFG$, $m\angle C = 4x + 30$, and $m\angle G = 5x + 10$. Determine the value of x .

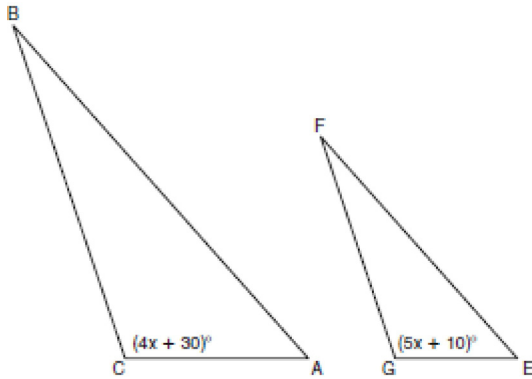

3 The base of a pyramid is a rectangle with a width of 6 cm and a length of 8 cm. Find, in centimeters, the height of the pyramid if the volume is 288 cm^3 .

4 Write an equation for circle O shown on the graph below.

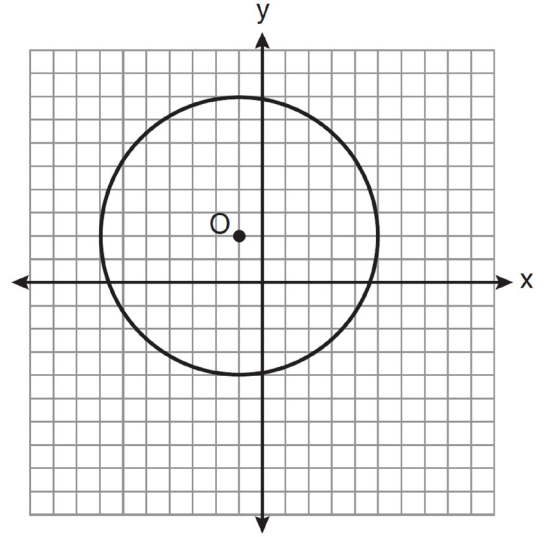

5 In the diagram of $\triangle ABC$ below, $AB = 10$, $BC = 14$, and $AC = 16$. Find the perimeter of the triangle formed by connecting the midpoints of the sides of $\triangle ABC$.

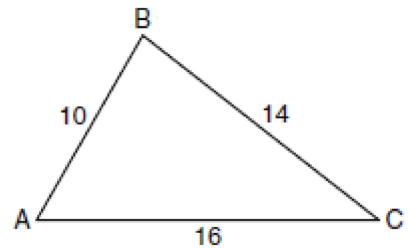

6 Given: Two is an even integer or three is an even integer.
Determine the truth value of this disjunction.
Justify your answer.

Geometry 2 Point Regents Exam Questions

www.jmap.org

- 7 In $\triangle RST$, $m\angle RST = 46$ and $\overline{RS} \cong \overline{ST}$. Find $m\angle STR$.

- 8 In the diagram below of $\triangle TEM$, medians \overline{TB} , \overline{EC} , and \overline{MA} intersect at D , and $TB = 9$. Find the length of TD .

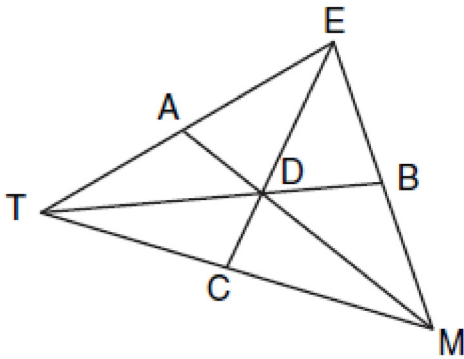

- 9 On the line segment below, use a compass and straightedge to construct equilateral triangle ABC . [Leave all construction marks.]



- 10 Tim is going to paint a wooden sphere that has a diameter of 12 inches. Find the surface area of the sphere, to the nearest square inch.

- 11 Using a compass and straightedge, and \overline{AB} below, construct an equilateral triangle with all sides congruent to \overline{AB} . [Leave all construction marks.]



- 12 Using a compass and straightedge, construct the bisector of the angle shown below. [Leave all construction marks.]

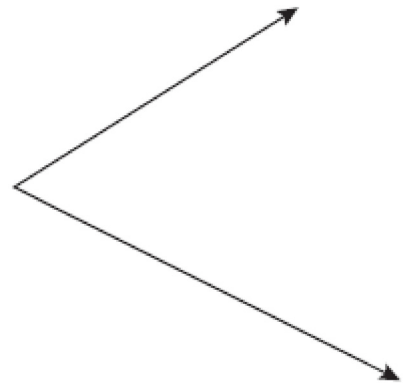

- 13 Tim has a rectangular prism with a length of 10 centimeters, a width of 2 centimeters, and an unknown height. He needs to build another rectangular prism with a length of 5 centimeters and the same height as the original prism. The volume of the two prisms will be the same. Find the width, in centimeters, of the new prism.

Geometry 2 Point Regents Exam Questions

www.jmap.org

- 14 Using a compass and straightedge, construct the angle bisector of $\angle ABC$ shown below. [Leave all construction marks.]

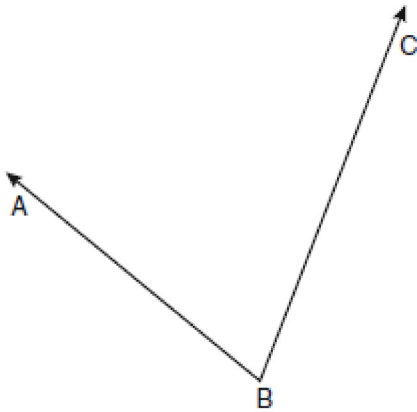

- 15 Find an equation of the line passing through the point (5,4) and parallel to the line whose equation is $2x + y = 3$.

- 16 In the diagram below of $\triangle ABC$ with side \overline{AC} extended through D , $m\angle A = 37$ and $m\angle BCD = 117$. Which side of $\triangle ABC$ is the longest side? Justify your answer.

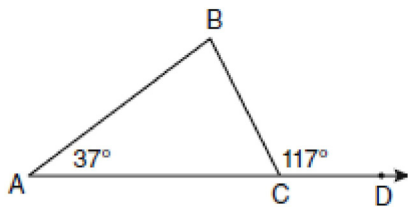

(Not drawn to scale)

- 17 A right circular cone has a base with a radius of 15 cm, a vertical height of 20 cm, and a slant height of 25 cm. Find, in terms of π , the number of square centimeters in the lateral area of the cone.

- 18 Two lines, \overleftrightarrow{AB} and \overleftrightarrow{CRD} , are parallel and 10 inches apart. Sketch the locus of all points that are equidistant from \overleftrightarrow{AB} and \overleftrightarrow{CRD} and 7 inches from point R . Label with an **X** each point that satisfies both conditions.



- 19 In right $\triangle DEF$, $m\angle D = 90$ and $m\angle F$ is 12 degrees less than twice $m\angle E$. Find $m\angle E$.
- 20 Using a compass and straightedge, construct a line that passes through point P and is perpendicular to line m . [Leave all construction marks.]

+ P



Geometry 2 Point Regents Exam Questions

www.jmap.org

- 21 Write a statement that is logically equivalent to the statement “If two sides of a triangle are congruent, the angles opposite those sides are congruent.” Identify the new statement as the converse, inverse, or contrapositive of the original statement.

- 22 In the diagram below of isosceles trapezoid $DEFG$, $\overline{DE} \parallel \overline{GF}$, $DE = 4x - 2$, $EF = 3x + 2$, $FG = 5x - 3$, and $GD = 2x + 5$. Find the value of x .

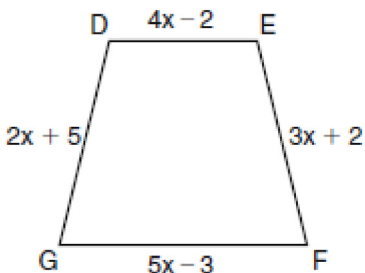

- 23 In the diagram below of $\triangle HQP$, side \overline{HP} is extended through P to T , $m\angle QPT = 6x + 20$, $m\angle HQP = x + 40$, and $m\angle PHQ = 4x - 5$. Find $m\angle QPT$.

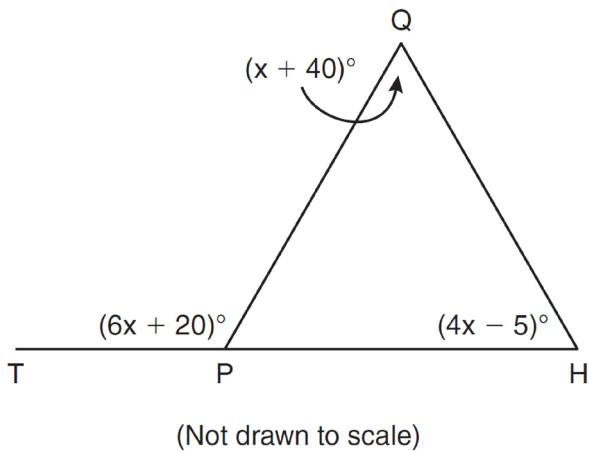

- 24 In the diagram below of $\triangle ABC$, \overline{DE} is a midsegment of $\triangle ABC$, $DE = 7$, $AB = 10$, and $BC = 13$. Find the perimeter of $\triangle ABC$.

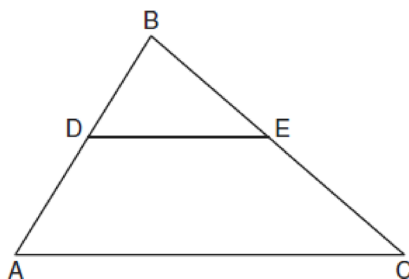

- 25 The diagram below shows isosceles trapezoid $ABCD$ with $\overline{AB} \parallel \overline{DC}$ and $\overline{AD} \cong \overline{BC}$. If $m\angle BAD = 2x$ and $m\angle BCD = 3x + 5$, find $m\angle BAD$.

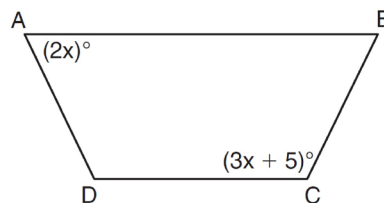

- 26 In the diagram below of $\triangle ACD$, E is a point on \overline{AD} and B is a point on \overline{AC} , such that $\overline{EB} \parallel \overline{DC}$. If $\overline{AE} = 3$, $\overline{ED} = 6$, and $\overline{DC} = 15$, find the length of \overline{EB} .

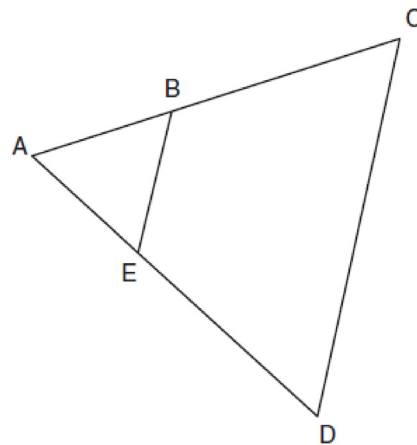

Geometry 2 Point Regents Exam Questions

www.jmap.org

- 27 In the diagram below of circle C , \overline{QR} is a diameter, and $Q(1,8)$ and $C(3.5,2)$ are points on a coordinate plane. Find and state the coordinates of point R .

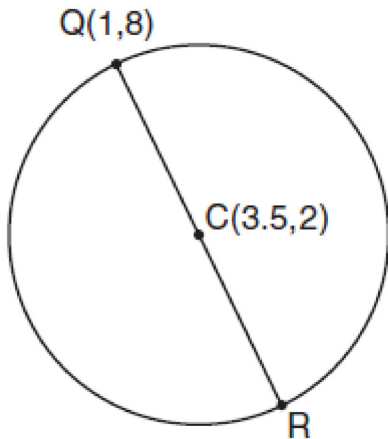

- 28 In the diagram below, car A is parked 7 miles from car B . Sketch the points that are 4 miles from car A and sketch the points that are 4 miles from car B . Label with an \mathbf{X} all points that satisfy both conditions.

Car A
●

Car B
●

- 29 The degree measures of the angles of $\triangle ABC$ are represented by x , $3x$, and $5x - 54$. Find the value of x .

- 30 In the diagram below of right triangle ACB , altitude \overline{CD} intersects \overline{AB} at D . If $AD = 3$ and $DB = 4$, find the length of CD in simplest radical form.

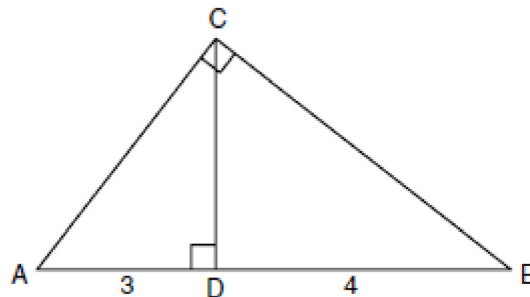

- 31 The vertices of $\triangle ABC$ are $A(3,2)$, $B(6,1)$, and $C(4,6)$. Identify and graph a transformation of $\triangle ABC$ such that its image, $\triangle A'B'C'$, results in $\overline{AB} \parallel \overline{A'B'}$.

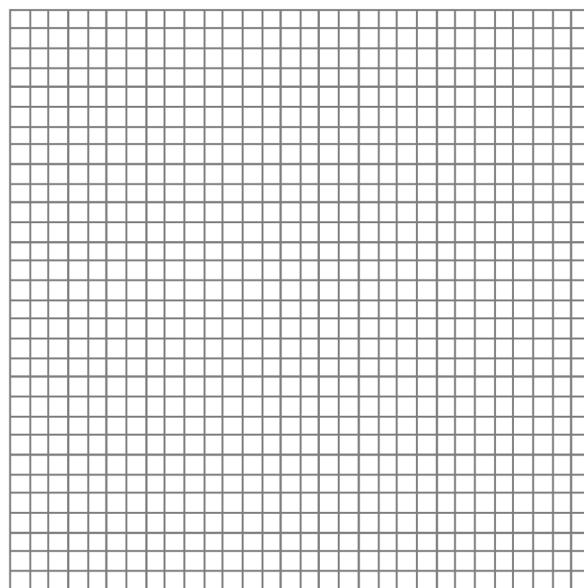

- 32 The endpoints of \overline{PQ} are $P(-3,1)$ and $Q(4,25)$. Find the length of \overline{PQ} .

Geometry 2 Point Regents Exam Questions

www.jmap.org

- 33 The volume of a cylinder is $12,566.4 \text{ cm}^3$. The height of the cylinder is 8 cm. Find the radius of the cylinder to the *nearest tenth of a centimeter*.

- 34 A regular pyramid with a square base is shown in the diagram below.

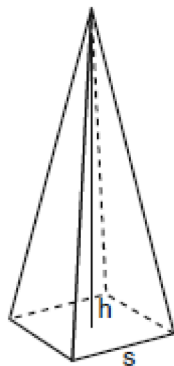

A side, s , of the base of the pyramid is 12 meters, and the height, h , is 42 meters. What is the volume of the pyramid in cubic meters?

- 35 Triangle XYZ , shown in the diagram below, is reflected over the line $x = 2$. State the coordinates of $\triangle X'Y'Z'$, the image of $\triangle XYZ$.

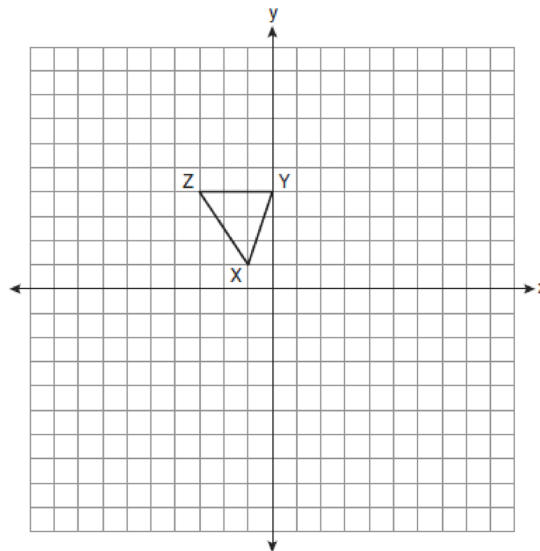

- 36 The length of \overline{AB} is 3 inches. On the diagram below, sketch the points that are equidistant from A and B and sketch the points that are 2 inches from A . Label with an **X** all points that satisfy both conditions.

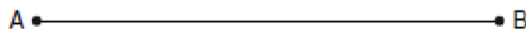

Geometry 4 Point Regents Exam Questions

- 1 In the diagram below of quadrilateral $ABCD$ with diagonal \overline{BD} , $m\angle A = 93$, $m\angle ADB = 43$, $m\angle C = 3x + 5$, $m\angle BDC = x + 19$, and $m\angle DBC = 2x + 6$. Determine if \overline{AB} is parallel to \overline{DC} . Explain your reasoning.

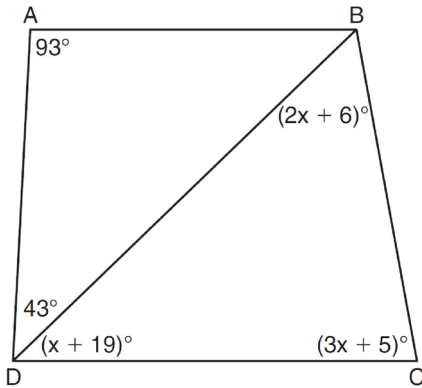

- 2 In the diagram below, $\triangle RST$ is a 3-4-5 right triangle. The altitude, h , to the hypotenuse has been drawn. Determine the length of h .

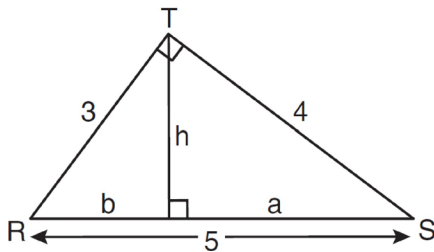

- 3 In $\triangle KLM$, $m\angle K = 36$ and $KM = 5$. The transformation D_2 is performed on $\triangle KLM$ to form $\triangle K'L'M'$. Find $m\angle K'$. Justify your answer. Find the length of $K'M'$. Justify your answer.

- 4 Write an equation of the circle whose diameter \overline{AB} has endpoints $A(-4, 2)$ and $B(4, -4)$. [The use of the grid below is optional.]

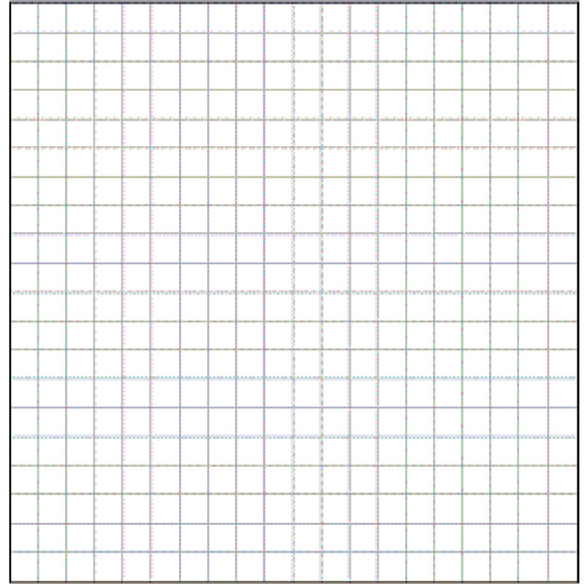

- 5 Write an equation of the perpendicular bisector of the line segment whose endpoints are $(-1, 1)$ and $(7, -5)$. [The use of the grid below is optional.]

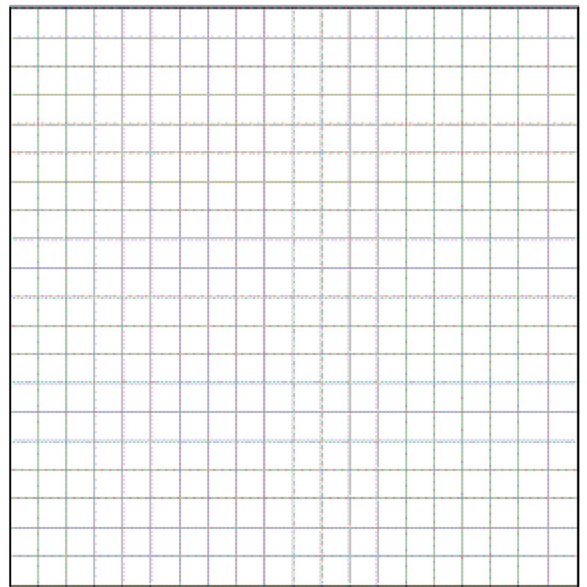

Geometry 4 Point Regents Exam Questions

www.jmap.org

- 6 On the set of axes below, graph and label $\triangle DEF$ with vertices at $D(-4, -4)$, $E(-2, 2)$, and $F(8, -2)$. If G is the midpoint of \overline{EF} and H is the midpoint of \overline{DF} , state the coordinates of G and H and label \overline{GH} . Explain why $\overline{GH} \parallel \overline{DE}$.

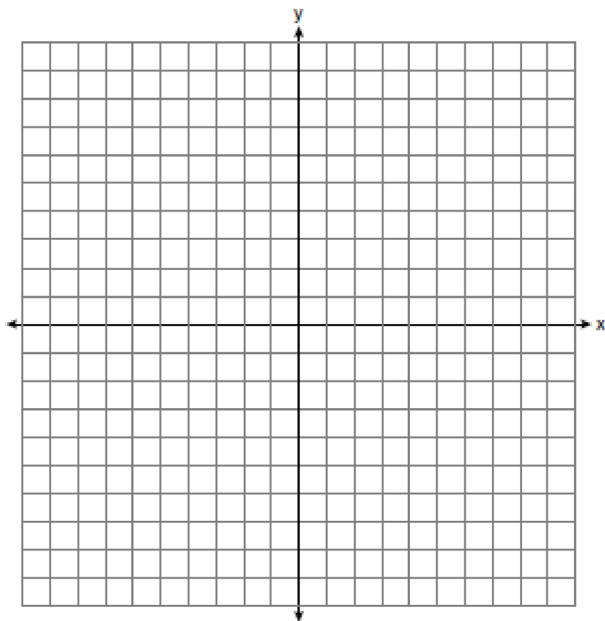

- 7 In the diagram below of circle O , chords \overline{DF} , \overline{DE} , \overline{FG} , and \overline{EG} are drawn such that $m\widehat{DF} : m\widehat{FE} : m\widehat{EG} : m\widehat{GD} = 5 : 2 : 1 : 7$. Identify one pair of inscribed angles that are congruent to each other and give their measure.

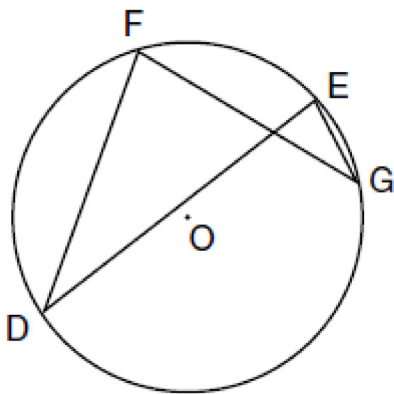

- 8 Triangle DEG has the coordinates $D(1, 1)$, $E(5, 1)$, and $G(5, 4)$. Triangle DEG is rotated 90° about the origin to form $\triangle D'E'G'$. On the grid below, graph and label $\triangle DEG$ and $\triangle D'E'G'$. State the coordinates of the vertices D' , E' , and G' . Justify that this transformation preserves distance.

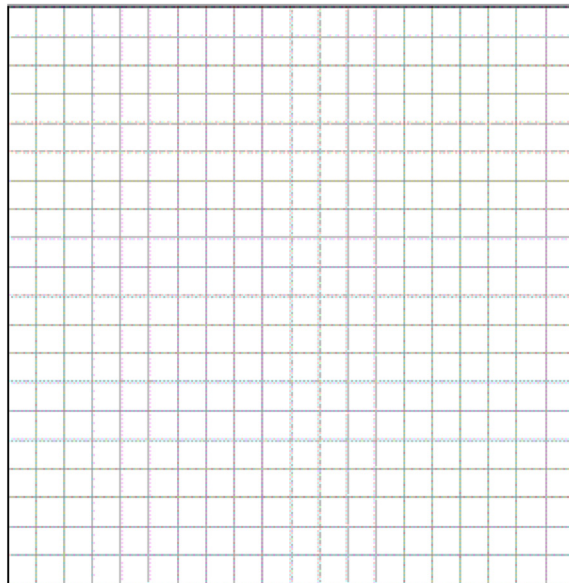

- 9 Triangle ABC has coordinates $A(-6, 2)$, $B(-3, 6)$, and $C(5, 0)$. Find the perimeter of the triangle. Express your answer in simplest radical form. [The use of the grid below is optional.]

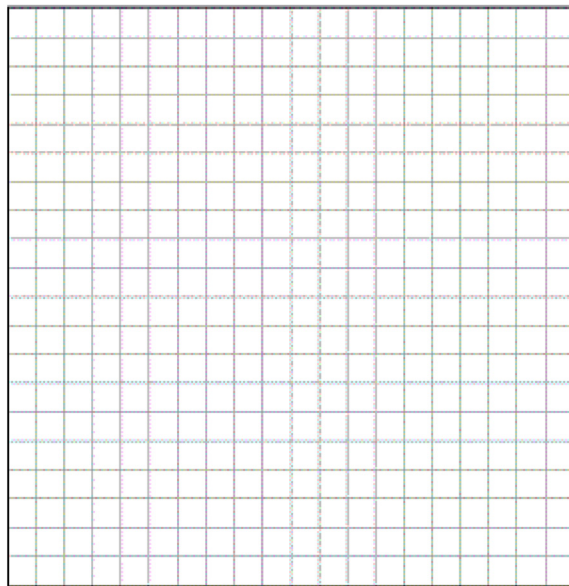

Geometry 4 Point Regents Exam Questions

www.jmap.org

- 10 On the grid below, graph the points that are equidistant from both the x and y axes and the points that are 5 units from the origin. Label with an **X** all points that satisfy both conditions.

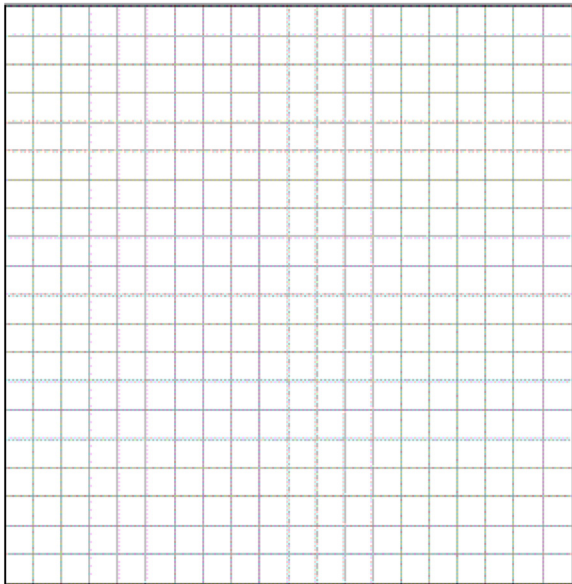

- 11 Find an equation of the line passing through the point $(6,5)$ and perpendicular to the line whose equation is $2y + 3x = 6$.

- 12 The coordinates of the vertices of parallelogram $ABCD$ are $A(-2,2)$, $B(3,5)$, $C(4,2)$, and $D(-1,-1)$. State the coordinates of the vertices of parallelogram $A''B''C''D''$ that result from the transformation $r_{y\text{-axis}} \circ T_{2,-3}$. [The use of the set of axes below is optional.]

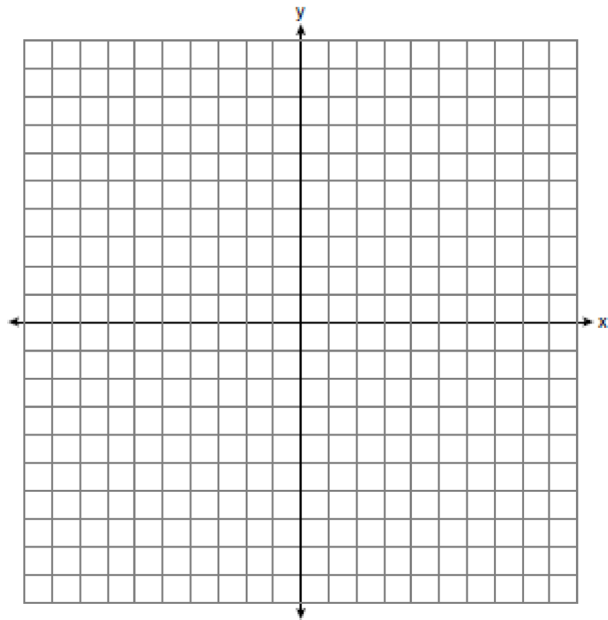

- 13 In the diagram below, circles X and Y have two tangents drawn to them from external point T . The points of tangency are $C, A, S,$ and E . The ratio of \overline{TA} to \overline{AC} is $1:3$. If $\overline{TS} = 24$, find the length of \overline{SE} .

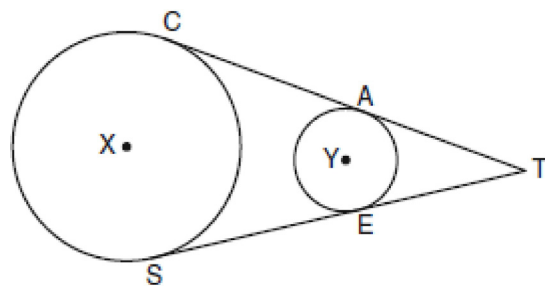

(Not drawn to scale)

Geometry 4 Point Regents Exam Questions

www.jmap.org

- 14 A city is planning to build a new park. The park must be equidistant from school A at $(3,3)$ and school B at $(3,-5)$. The park also must be exactly 5 miles from the center of town, which is located at the origin on the coordinate graph. Each unit on the graph represents 1 mile. On the set of axes below, sketch the compound loci and label with an **X** all possible locations for the new park.

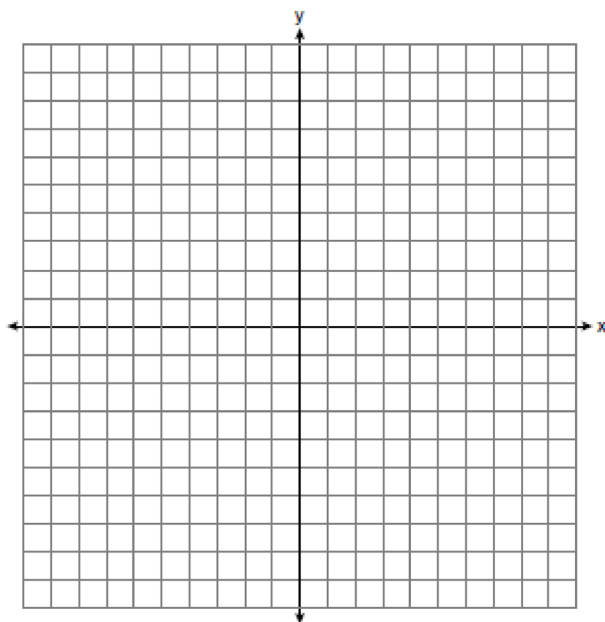

- 15 Given: \overline{JKLM} is a parallelogram.

$$\overline{JM} \cong \overline{LN}$$

$$\angle LMN \cong \angle LNM$$

Prove: \overline{JKLM} is a rhombus.

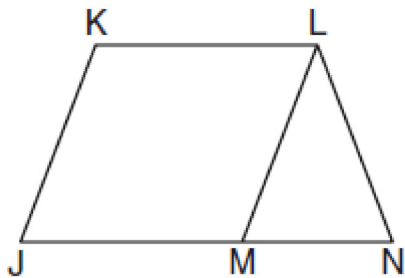

- 16 Given: Quadrilateral $ABCD$ with $\overline{AB} \cong \overline{CD}$,

$$\overline{AD} \cong \overline{BC}, \text{ and diagonal } \overline{BD} \text{ is drawn}$$

Prove: $\angle BDC \cong \angle ABD$

- 17 The coordinates of the vertices of $\triangle ABC$ $A(1,3)$, $B(-2,2)$ and $C(0,-2)$. On the grid below, graph and label $\triangle A''B''C''$, the result of the composite transformation $D_2 \circ T_{3,-2}$. State the coordinates of A'' , B'' , and C'' .

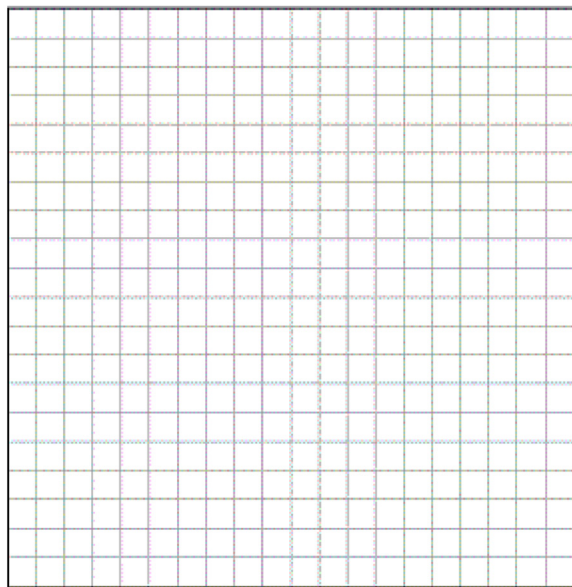

- 18 On the set of axes below, sketch the points that are 5 units from the origin and sketch the points that are 2 units from the line $y = 3$. Label with an **X** all points that satisfy both conditions.

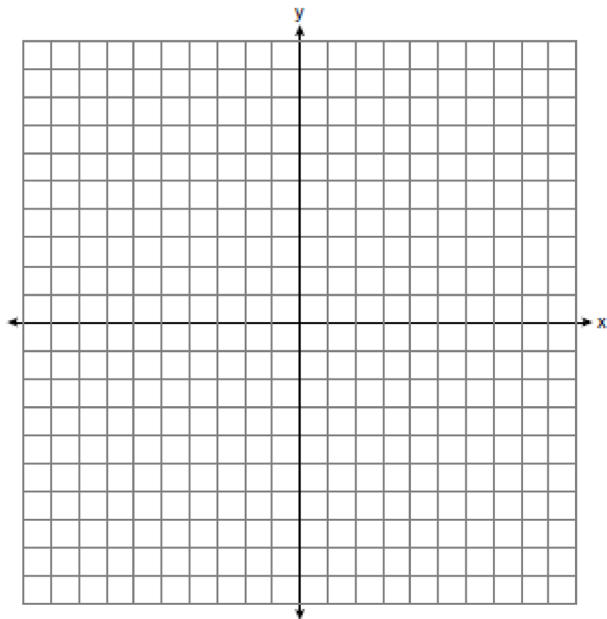

Geometry 6 Point Regents Exam Questions

- 1 Given: Quadrilateral $ABCD$, diagonal \overline{AFEC} ,
 $\overline{AE} \cong \overline{FC}$, $\overline{BF} \perp \overline{AC}$, $\overline{DE} \perp \overline{AC}$, $\angle 1 \cong \angle 2$
Prove: $ABCD$ is a parallelogram.

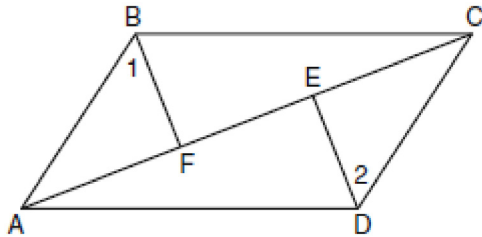

- 2 In the diagram below, quadrilateral $ABCD$ is inscribed in circle O , $\overline{AB} \parallel \overline{DC}$, and diagonals \overline{AC} and \overline{BD} are drawn. Prove that $\triangle ACD \cong \triangle BDC$.

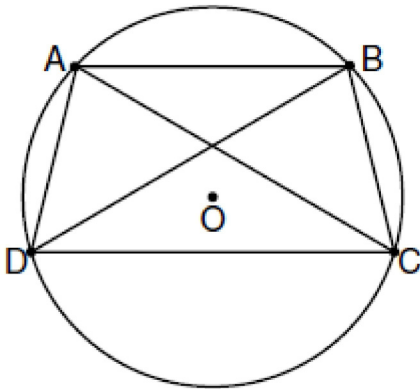

- 3 On the set of axes below, solve the following system of equations graphically for all values of x and y .

$$y = (x - 2)^2 + 4$$

$$4x + 2y = 14$$

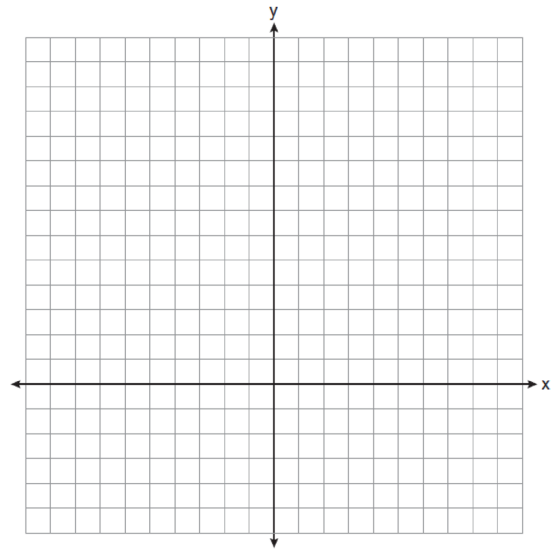

- 4 Given: $\triangle ABC$ and $\triangle EDC$, C is the midpoint of \overline{BD} and \overline{AE}
Prove: $\overline{AB} \parallel \overline{DE}$

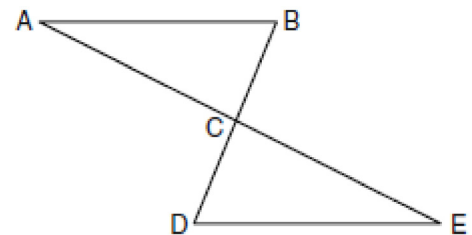

Geometry 6 Point Regents Exam Questions

www.jmap.org

- 5 Given: Quadrilateral $ABCD$ has vertices $A(-5,6)$, $B(6,6)$, $C(8,-3)$, and $D(-3,-3)$.
 Prove: Quadrilateral $ABCD$ is a parallelogram but is neither a rhombus nor a rectangle. [The use of the grid below is optional.]

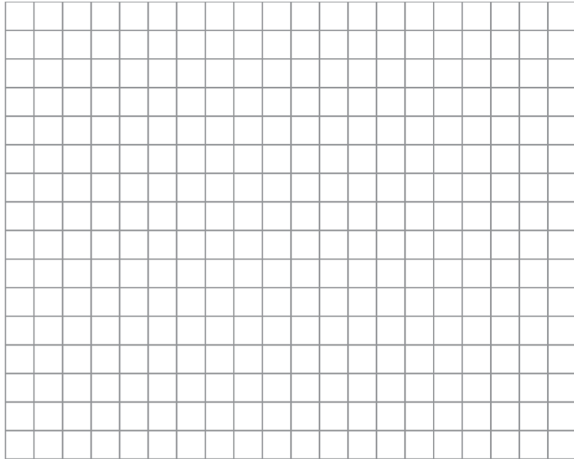

- 6 In the diagram below, quadrilateral $STAR$ is a rhombus with diagonals \overline{SA} and \overline{TR} intersecting at E . $ST = 3x + 30$, $SR = 8x - 5$, $SE = 3z$, $TE = 5z + 5$, $AE = 4z - 8$, $m\angle RTA = 5y - 2$, and $m\angle TAS = 9y + 8$. Find SR , RT , and $m\angle TAS$.

