

JEFFERSON MATH PROJECT

REGENTS BY TYPE

The NY Geometry Regents Exams
Fall 2007-January 2010

www.jmap.org

Dear Sir

I have to acknowledge the receipt of your favor of May 14. in which you mention that you have finished the 6. first books of Euclid, plane trigonometry, surveying & algebra and ask whether I think a further pursuit of that branch of science would be useful to you. there are some propositions in the latter books of Euclid, & some of Archimedes, which are useful, & I have no doubt you have been made acquainted with them. trigonometry, so far as this, is most valuable to every man, there is scarcely a day in which he will not resort to it for some of the purposes of common life. the science of calculation also is indispensable as far as the extraction of the square & cube roots; Algebra as far as the quadratic equation & the use of logarithms are often of value in ordinary cases: but all beyond these is but a luxury; a delicious luxury indeed; but not to be indulged in by one who is to have a profession to follow for his subsistence. in this light I view the conic sections, curves of the higher orders, perhaps even spherical trigonometry, Algebraical operations beyond the 2d dimension, and fluxions.

Letter from Thomas Jefferson to William G. Munford, Monticello, June 18, 1799.

Geometry Multiple Choice Regents Exam Questions

- 1 A circle is represented by the equation $x^2 + (y + 3)^2 = 13$. What are the coordinates of the center of the circle and the length of the radius?
- 1) $(0, 3)$ and 13
 - 2) $(0, 3)$ and $\sqrt{13}$
 - 3) $(0, -3)$ and 13
 - 4) $(0, -3)$ and $\sqrt{13}$

- 2 The diagram below shows the construction of the perpendicular bisector of \overline{AB} .

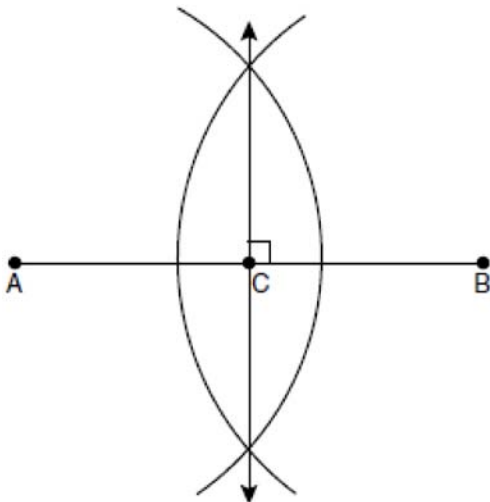

Which statement is *not* true?

- 1) $AC = CB$
- 2) $CB = \frac{1}{2} AB$
- 3) $AC = 2AB$
- 4) $AC + CB = AB$

- 3 Which transformation is *not* always an isometry?
- 1) rotation
 - 2) dilation
 - 3) reflection
 - 4) translation

- 4 What is the slope of a line perpendicular to the line whose equation is $5x + 3y = 8$?

- 1) $\frac{5}{3}$
- 2) $\frac{3}{5}$
- 3) $-\frac{3}{5}$
- 4) $-\frac{5}{3}$

- 5 In $\triangle ABC$, $m\angle A = 95$, $m\angle B = 50$, and $m\angle C = 35$. Which expression correctly relates the lengths of the sides of this triangle?

- 1) $AB < BC < CA$
- 2) $AB < AC < BC$
- 3) $AC < BC < AB$
- 4) $BC < AC < AB$

- 6 What is the slope of a line that is perpendicular to the line whose equation is $3x + 4y = 12$?

- 1) $\frac{3}{4}$
- 2) $-\frac{3}{4}$
- 3) $\frac{4}{3}$
- 4) $-\frac{4}{3}$

- 7 In the diagram of $\triangle ABC$ and $\triangle EDC$ below, \overline{AE} and \overline{BD} intersect at C , and $\angle CAB \cong \angle CED$.

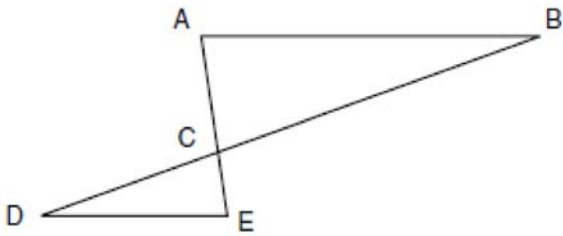

Which method can be used to show that $\triangle ABC$ must be similar to $\triangle EDC$?

- 1) SAS
 - 2) AA
 - 3) SSS
 - 4) HL
- 8 In the diagram of circle O below, chords \overline{AB} and \overline{CD} are parallel, and \overline{BD} is a diameter of the circle.

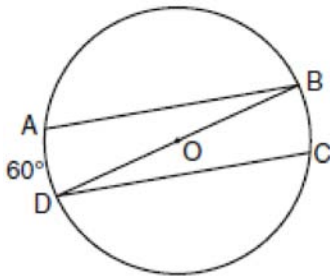

If $m\widehat{AD} = 60$, what is $m\angle CDB$?

- 9 In the diagram below, circle A and circle B are shown.

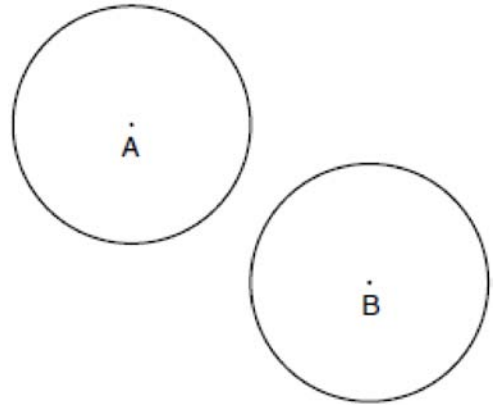

What is the total number of lines of tangency that are common to circle A and circle B ?

- 1) 1
 - 2) 2
 - 3) 3
 - 4) 4
- 10 In the diagram below of $\triangle PRT$, Q is a point on \overline{PR} , S is a point on \overline{TR} , \overline{QS} is drawn, and $\angle RPT \cong \angle RSQ$.

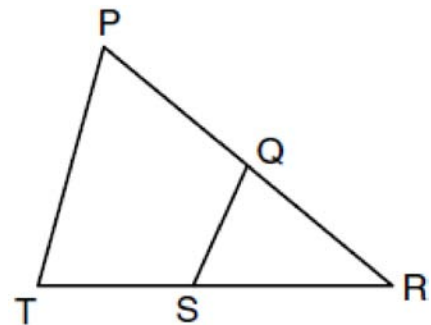

Which reason justifies the conclusion that $\triangle PRT \sim \triangle SRQ$?

- 1) AA
- 2) ASA
- 3) SAS
- 4) SSS

- 11 Which graph represents a circle with the equation $(x-5)^2 + (y+1)^2 = 9$?

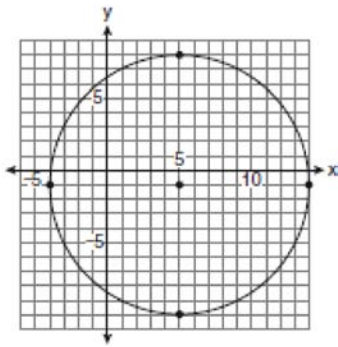
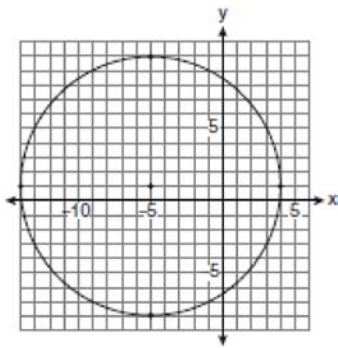
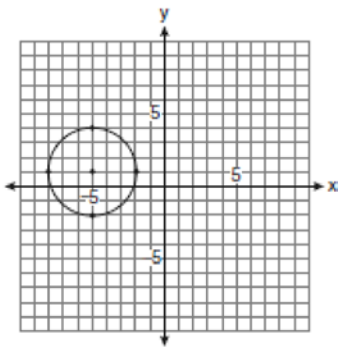
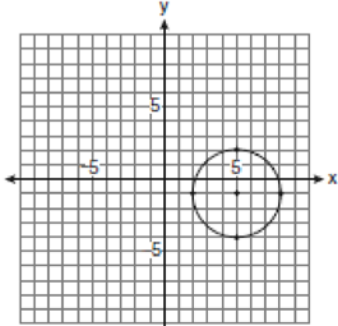

- 12 In the diagram below, tangent \overline{AB} and secant \overline{ACD} are drawn to circle O from an external point A , $AB = 8$, and $AC = 4$.

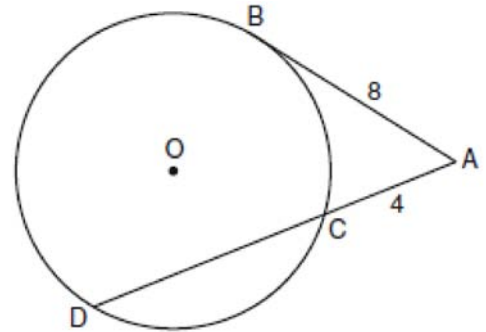

What is the length of \overline{CD} ?

- 1) 16
 2) 13
 3) 12
 4) 10
- 13 In the diagram below, tangent \overline{PA} and secant \overline{PBC} are drawn to circle O from external point P .

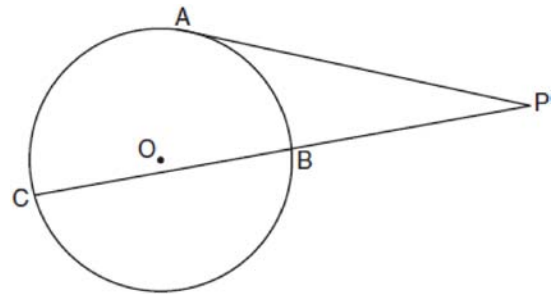

If $PB = 4$ and $BC = 5$, what is the length of \overline{PA} ?

- 1) 20
 2) 9
 3) 8
 4) 6

- 14 In the diagram below, $\triangle ABC$ is shown with \overline{AC} extended through point D .

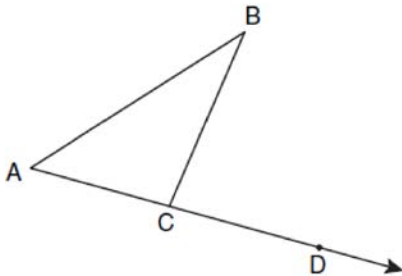

If $m\angle BCD = 6x + 2$, $m\angle BAC = 3x + 15$, and $m\angle ABC = 2x - 1$, what is the value of x ?

- 1) 12
 - 2) $14\frac{10}{11}$
 - 3) 16
 - 4) $18\frac{1}{9}$
- 15 The endpoints of \overline{CD} are $C(-2, -4)$ and $D(6, 2)$.
What are the coordinates of the midpoint of \overline{CD} ?
- 1) (2, 3)
 - 2) (2, -1)
 - 3) (4, -2)
 - 4) (4, 3)
- 16 In an equilateral triangle, what is the difference between the sum of the exterior angles and the sum of the interior angles?
- 1) 180°
 - 2) 120°
 - 3) 90°
 - 4) 60°

- 17 The diagram below shows the construction of the center of the circle circumscribed about $\triangle ABC$.

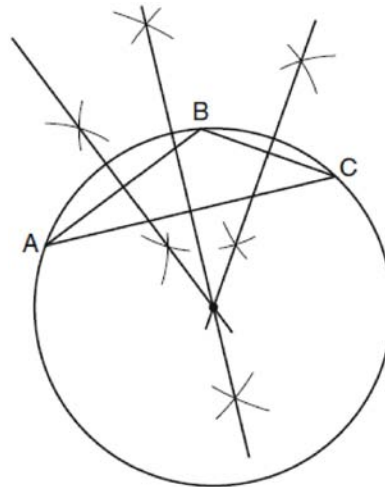

This construction represents how to find the intersection of

- 1) the angle bisectors of $\triangle ABC$
 - 2) the medians to the sides of $\triangle ABC$
 - 3) the altitudes to the sides of $\triangle ABC$
 - 4) the perpendicular bisectors of the sides of $\triangle ABC$
- 18 Point A is located at $(4, -7)$. The point is reflected in the x -axis. Its image is located at
- 1) $(-4, 7)$
 - 2) $(-4, -7)$
 - 3) $(4, 7)$
 - 4) $(7, -4)$
- 19 What is the contrapositive of the statement, "If I am tall, then I will bump my head"?
- 1) If I bump my head, then I am tall.
 - 2) If I do not bump my head, then I am tall.
 - 3) If I am tall, then I will not bump my head.
 - 4) If I do not bump my head, then I am not tall.

Geometry Multiple Choice Regents Exam Questions

www.jmap.org

- 20 After a composition of transformations, the coordinates $A(4,2)$, $B(4,6)$, and $C(2,6)$ become $A''(-2,-1)$, $B''(-2,-3)$, and $C''(-1,-3)$, as shown on the set of axes below.

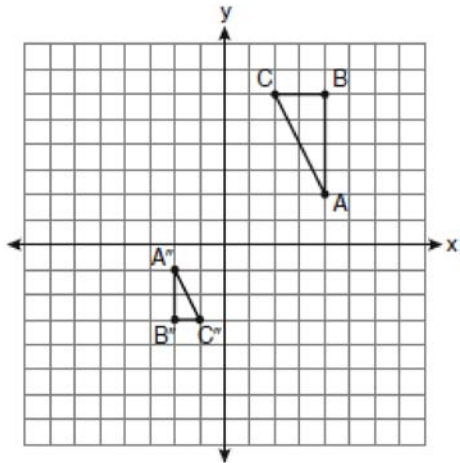

Which composition of transformations was used?

- 1) $R_{180^\circ} \circ D_2$
 - 2) $R_{90^\circ} \circ D_2$
 - 3) $D_{\frac{1}{2}} \circ R_{180^\circ}$
 - 4) $D_{\frac{1}{2}} \circ R_{90^\circ}$
- 21 Through a given point, P , on a plane, how many lines can be drawn that are perpendicular to that plane?
- 1) 1
 - 2) 2
 - 3) more than 2
 - 4) none

- 22 In $\triangle ABC$, $\overline{AB} \cong \overline{BC}$. An altitude is drawn from B to \overline{AC} and intersects \overline{AC} at D . Which conclusion is *not* always true?
- 1) $\angle ABD \cong \angle CBD$
 - 2) $\angle BDA \cong \angle BDC$
 - 3) $\overline{AD} \cong \overline{BD}$
 - 4) $\overline{AD} \cong \overline{DC}$

- 23 A rectangular prism has a volume of $3x^2 + 18x + 24$. Its base has a length of $x + 2$ and a width of 3. Which expression represents the height of the prism?
- 1) $x + 4$
 - 2) $x + 2$
 - 3) 3
 - 4) $x^2 + 6x + 8$

- 24 In the diagram of $\triangle ABC$ and $\triangle DEF$ below, $\overline{AB} \cong \overline{DE}$, $\angle A \cong \angle D$, and $\angle B \cong \angle E$.

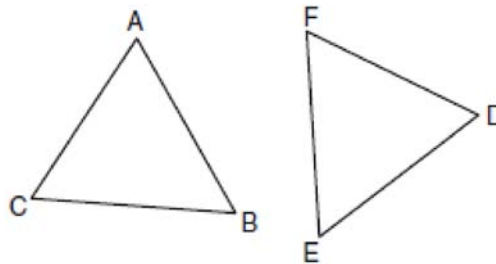

Which method can be used to prove $\triangle ABC \cong \triangle DEF$?

- 1) SSS
- 2) SAS
- 3) ASA
- 4) HL

Geometry Multiple Choice Regents Exam Questions

www.jmap.org

25 What is the equation of a line that is parallel to the line whose equation is $y = x + 2$?

- 1) $x + y = 5$
- 2) $2x + y = -2$
- 3) $y - x = -1$
- 4) $y - 2x = 3$

26 Which equation represents a line perpendicular to the line whose equation is $2x + 3y = 12$?

- 1) $6y = -4x + 12$
- 2) $2y = 3x + 6$
- 3) $2y = -3x + 6$
- 4) $3y = -2x + 12$

27 Which expression represents the volume, in cubic centimeters, of the cylinder represented in the diagram below?

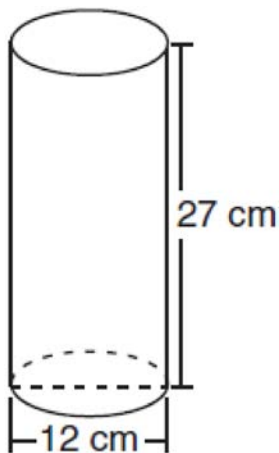

- 1) 162π
- 2) 324π
- 3) 972π
- 4) $3,888\pi$

28 In the diagram below, $\triangle ABC$ is inscribed in circle P . The distances from the center of circle P to each side of the triangle are shown.

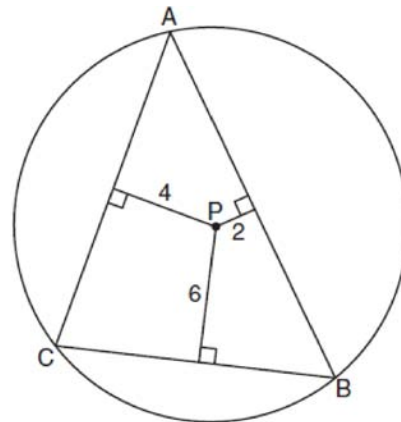

Which statement about the sides of the triangle is true?

- 1) $AB > AC > BC$
- 2) $AB < AC$ and $AC > BC$
- 3) $AC > AB > BC$
- 4) $AC = AB$ and $AB > BC$

29 The diameter of a circle has endpoints at $(-2, 3)$ and $(6, 3)$. What is an equation of the circle?

- 1) $(x - 2)^2 + (y - 3)^2 = 16$
- 2) $(x - 2)^2 + (y - 3)^2 = 4$
- 3) $(x + 2)^2 + (y + 3)^2 = 16$
- 4) $(x + 2)^2 + (y + 3)^2 = 4$

30 If two different lines are perpendicular to the same plane, they are

- 1) collinear
- 2) coplanar
- 3) congruent
- 4) consecutive

Geometry Multiple Choice Regents Exam Questions

www.jmap.org

- 31 In the diagram below of $\triangle ADB$, $m\angle BDA = 90$, $AD = 5\sqrt{2}$, and $AB = 2\sqrt{15}$.

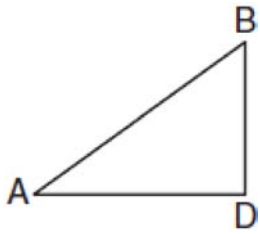

What is the length of \overline{BD} ?

- 1) $\sqrt{10}$
 - 2) $\sqrt{20}$
 - 3) $\sqrt{50}$
 - 4) $\sqrt{110}$
- 32 Line k is drawn so that it is perpendicular to two distinct planes, P and R . What must be true about planes P and R ?
- 1) Planes P and R are skew.
 - 2) Planes P and R are parallel.
 - 3) Planes P and R are perpendicular.
 - 4) Plane P intersects plane R but is not perpendicular to plane R .
- 33 The endpoints of \overline{AB} are $A(3,2)$ and $B(7,1)$. If $\overline{A''B''}$ is the result of the transformation of \overline{AB} under $D_2 \circ T_{-4,3}$ what are the coordinates of A'' and B'' ?
- 1) $A''(-2, 10)$ and $B''(6, 8)$
 - 2) $A''(-1, 5)$ and $B''(3, 4)$
 - 3) $A''(2, 7)$ and $B''(10, 5)$
 - 4) $A''(14, -2)$ and $B''(22, -4)$

- 34 What are the center and the radius of the circle whose equation is $(x - 3)^2 + (y + 3)^2 = 36$
- 1) center = $(3, -3)$; radius = 6
 - 2) center = $(-3, 3)$; radius = 6
 - 3) center = $(3, -3)$; radius = 36
 - 4) center = $(-3, 3)$; radius = 36

- 35 Two triangles are similar, and the ratio of each pair of corresponding sides is 2:1. Which statement regarding the two triangles is *not* true?
- 1) Their areas have a ratio of 4:1.
 - 2) Their altitudes have a ratio of 2:1.
 - 3) Their perimeters have a ratio of 2:1.
 - 4) Their corresponding angles have a ratio of 2:1.

- 36 In the diagram below, a right circular cone has a diameter of 8 inches and a height of 12 inches.

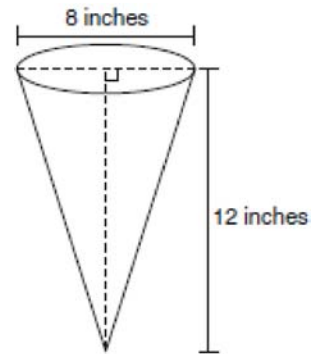

What is the volume of the cone to the nearest cubic inch?

- 1) 201
- 2) 481
- 3) 603
- 4) 804

Geometry Multiple Choice Regents Exam Questions

www.jmap.org

- 37 In the diagram below of circle O , chords \overline{AD} and \overline{BC} intersect at E , $m\widehat{AC} = 87$, and $m\widehat{BD} = 35$.

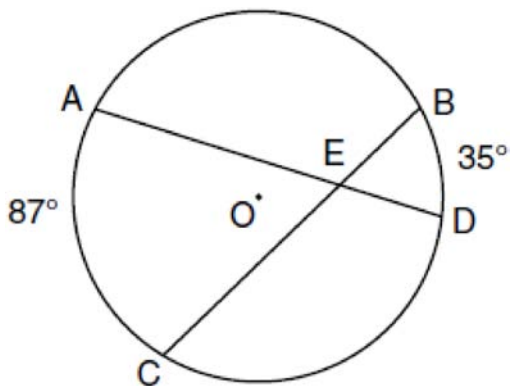

What is the degree measure of $\angle CEA$?

- 1) 87
 - 2) 61
 - 3) 43.5
 - 4) 26
- 38 What is the slope of a line perpendicular to the line whose equation is $y = -\frac{2}{3}x - 5$?
- 1) $-\frac{3}{2}$
 - 2) $-\frac{2}{3}$
 - 3) $\frac{2}{3}$
 - 4) $\frac{3}{2}$

- 39 In the diagram below, under which transformation will $\triangle A'B'C'$ be the image of $\triangle ABC$?

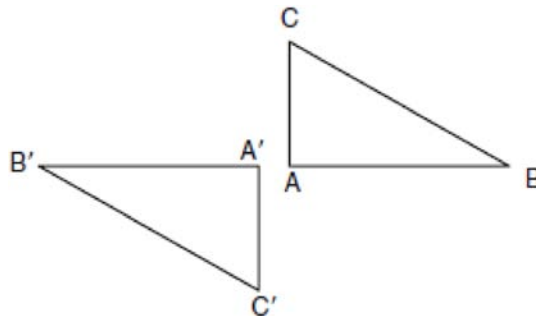

- 1) rotation
 - 2) dilation
 - 3) translation
 - 4) glide reflection
- 40 Juliann plans on drawing $\triangle ABC$, where the measure of $\angle A$ can range from 50° to 60° and the measure of $\angle B$ can range from 90° to 100° . Given these conditions, what is the correct range of measures possible for $\angle C$?
- 1) 20° to 40°
 - 2) 30° to 50°
 - 3) 80° to 90°
 - 4) 120° to 130°
- 41 A right circular cylinder has a volume of 1,000 cubic inches and a height of 8 inches. What is the radius of the cylinder to the nearest tenth of an inch?
- 1) 6.3
 - 2) 11.2
 - 3) 19.8
 - 4) 39.8

Geometry Multiple Choice Regents Exam Questions

www.jmap.org

- 42 Lines k_1 and k_2 intersect at point E . Line m is perpendicular to lines k_1 and k_2 at point E .

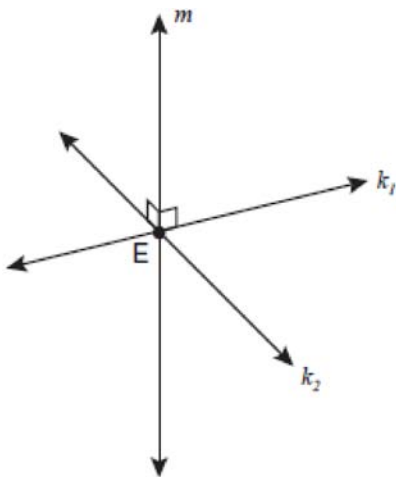

Which statement is always true?

- 1) Lines k_1 and k_2 are perpendicular.
- 2) Line m is parallel to the plane determined by lines k_1 and k_2 .
- 3) Line m is perpendicular to the plane determined by lines k_1 and k_2 .
- 4) Line m is coplanar with lines k_1 and k_2 .

- 43 In a coordinate plane, how many points are both 5 units from the origin and 2 units from the x -axis?

- 1) 1
- 2) 2
- 3) 3
- 4) 4

- 44 The diagonal \overline{AC} is drawn in parallelogram $ABCD$.

Which method can *not* be used to prove that

$\triangle ABC \cong \triangle CDA$?

- 1) SSS
- 2) SAS
- 3) SSA
- 4) ASA

- 45 Triangle ABC has vertices $A(1,3)$, $B(0,1)$, and $C(4,0)$. Under a translation, A' , the image point of A , is located at $(4,4)$. Under this same translation, point C' is located at

- 1) $(7,1)$
- 2) $(5,3)$
- 3) $(3,2)$
- 4) $(1,-1)$

- 46 What is the distance between the points $(-3,2)$ and $(1,0)$?

- 1) $2\sqrt{2}$
- 2) $2\sqrt{3}$
- 3) $5\sqrt{2}$
- 4) $2\sqrt{5}$

- 47 In the diagram below, circle O has a radius of 5, and $CE = 2$. Diameter \overline{AC} is perpendicular to chord \overline{BD} at E .

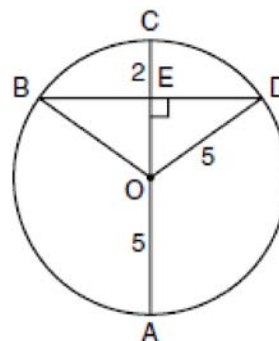

What is the length of \overline{BD} ?

- 1) 12
- 2) 10
- 3) 8
- 4) 4

Geometry Multiple Choice Regents Exam Questions

www.jmap.org

- 48 In the diagram below, the length of the legs \overline{AC} and \overline{BC} of right triangle ABC are 6 cm and 8 cm, respectively. Altitude \overline{CD} is drawn to the hypotenuse of $\triangle ABC$.

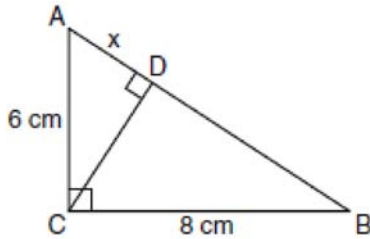

What is the length of \overline{AD} to the nearest tenth of a centimeter?

- 1) 3.6
 - 2) 6.0
 - 3) 6.4
 - 4) 4.0
- 49 In the diagram of circle O below, chord \overline{CD} is parallel to diameter \overline{AOB} and $m\widehat{AC} = 30$.

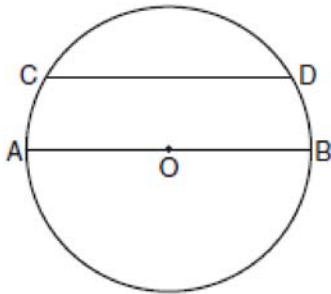

What is $m\widehat{CD}$?

- 1) 150
- 2) 120
- 3) 100
- 4) 60

- 50 What is an equation of a circle with its center at $(-3,5)$ and a radius of 4?
- 1) $(x-3)^2 + (y+5)^2 = 16$
 - 2) $(x+3)^2 + (y-5)^2 = 16$
 - 3) $(x-3)^2 + (y+5)^2 = 4$
 - 4) $(x+3)^2 + (y-5)^2 = 4$

- 51 What is the negation of the statement “The Sun is shining”?
- 1) It is cloudy.
 - 2) It is daytime.
 - 3) It is not raining.
 - 4) The Sun is not shining.

- 52 In the diagram below of parallelogram $ABCD$ with diagonals \overline{AC} and \overline{BD} , $m\angle 1 = 45$ and $m\angle DCB = 120$.

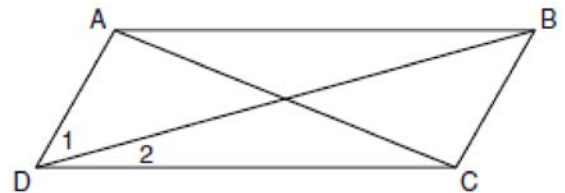

What is the measure of $\angle 2$?

- 1) 15°
- 2) 30°
- 3) 45°
- 4) 60°

Geometry Multiple Choice Regents Exam Questions

www.jmap.org

- 53 The equation of a circle is $(x - 2)^2 + (y + 4)^2 = 4$. Which diagram is the graph of the circle?

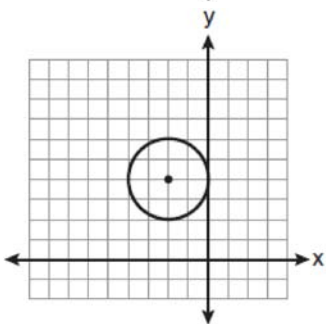
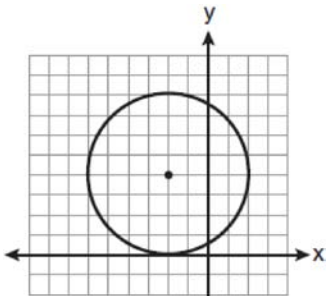
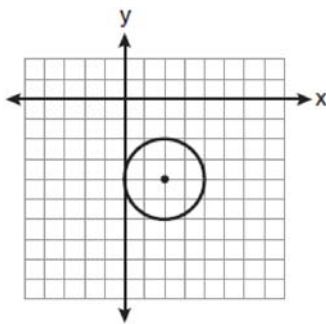
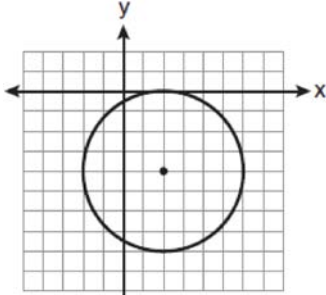

- 54 What are the center and radius of a circle whose equation is $(x - A)^2 + (y - B)^2 = C$?

- 1) center = (A, B) ; radius = C
- 2) center = $(-A, -B)$; radius = C
- 3) center = (A, B) ; radius = \sqrt{C}
- 4) center = $(-A, -B)$; radius = \sqrt{C}

- 55 In the diagram of $\triangle ABC$ below, $\overline{AB} \cong \overline{AC}$. The measure of $\angle B$ is 40° .

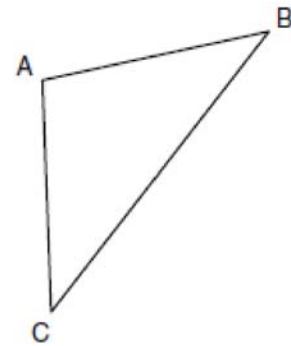

What is the measure of $\angle A$?

- 1) 40°
- 2) 50°
- 3) 70°
- 4) 100°

- 56 The vertices of $\triangle ABC$ are $A(-1, -2)$, $B(-1, 2)$ and $C(6, 0)$. Which conclusion can be made about the angles of $\triangle ABC$?

- 1) $m\angle A = m\angle B$
- 2) $m\angle A = m\angle C$
- 3) $m\angle ACB = 90$
- 4) $m\angle ABC = 60$

Geometry Multiple Choice Regents Exam Questions

www.jmap.org

- 57 On the set of axes below, Geoff drew rectangle $ABCD$. He will transform the rectangle by using the translation $(x,y) \rightarrow (x+2,y+1)$ and then will reflect the translated rectangle over the x -axis.

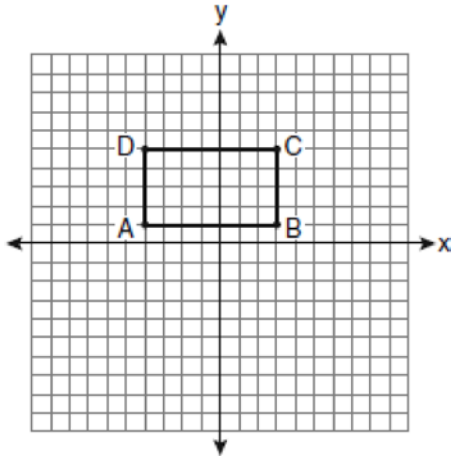

What will be the area of the rectangle after these transformations?

- 1) exactly 28 square units
 - 2) less than 28 square units
 - 3) greater than 28 square units
 - 4) It cannot be determined from the information given.
- 58 Towns A and B are 16 miles apart. How many points are 10 miles from town A and 12 miles from town B ?
- 1) 1
 - 2) 2
 - 3) 3
 - 4) 0

- 59 What is the negation of the statement “Squares are parallelograms”?
- 1) Parallelograms are squares.
 - 2) Parallelograms are not squares.
 - 3) It is not the case that squares are parallelograms.
 - 4) It is not the case that parallelograms are squares.

- 60 In the diagram below, line k is perpendicular to plane \mathcal{P} at point T .

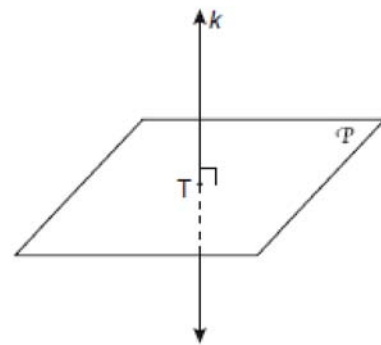

Which statement is true?

- 1) Any point in plane \mathcal{P} also will be on line k .
- 2) Only one line in plane \mathcal{P} will intersect line k .
- 3) All planes that intersect plane \mathcal{P} will pass through T .
- 4) Any plane containing line k is perpendicular to plane \mathcal{P} .

Geometry Multiple Choice Regents Exam Questions

www.jmap.org

- 61 In the diagram of trapezoid $ABCD$ below, diagonals \overline{AC} and \overline{BD} intersect at E and $\triangle ABC \cong \triangle DCB$.

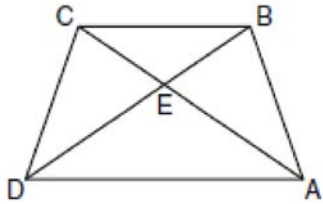

Which statement is true based on the given information?

- 1) $\overline{AC} \cong \overline{BC}$
 - 2) $\overline{CD} \cong \overline{AD}$
 - 3) $\angle CDE \cong \angle BAD$
 - 4) $\angle CDB \cong \angle BAC$
- 62 Line segment \overline{AB} has endpoints $A(2, -3)$ and $B(-4, 6)$. What are the coordinates of the midpoint of \overline{AB} ?
- 1) $(-2, 3)$
 - 2) $\left(-1, 1\frac{1}{2}\right)$
 - 3) $(-1, 3)$
 - 4) $\left(3, 4\frac{1}{2}\right)$
- 63 In which triangle do the three altitudes intersect outside the triangle?
- 1) a right triangle
 - 2) an acute triangle
 - 3) an obtuse triangle
 - 4) an equilateral triangle

- 64 The lateral faces of a regular pyramid are composed of
- 1) squares
 - 2) rectangles
 - 3) congruent right triangles
 - 4) congruent isosceles triangles

- 65 In the diagram below of right triangle ACB , altitude \overline{CD} is drawn to hypotenuse \overline{AB} .

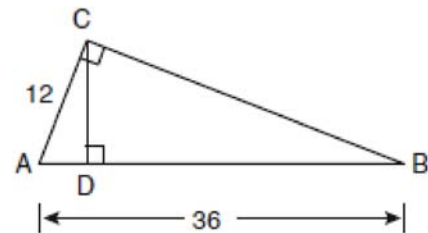

If $AB = 36$ and $AC = 12$, what is the length of \overline{AD} ?

- 1) 32
 - 2) 6
 - 3) 3
 - 4) 4
- 66 What is the equation of a line that passes through the point $(-3, -11)$ and is parallel to the line whose equation is $2x - y = 4$?
- 1) $y = 2x + 5$
 - 2) $y = 2x - 5$
 - 3) $y = \frac{1}{2}x + \frac{25}{2}$
 - 4) $y = -\frac{1}{2}x - \frac{25}{2}$

67 Which illustration shows the correct construction of an angle bisector?

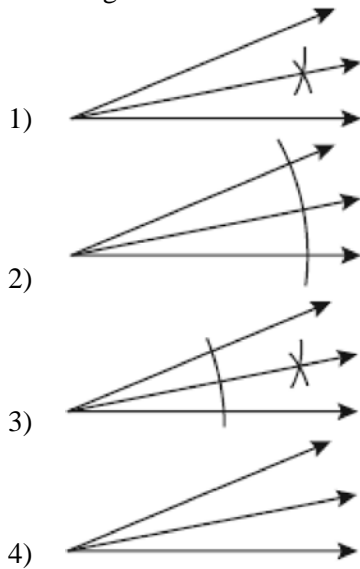

68 Given $\triangle ABC$ with base \overline{AFEDC} , median \overline{BF} , altitude \overline{BD} , and \overline{BE} bisects $\angle ABC$, which conclusion is valid?

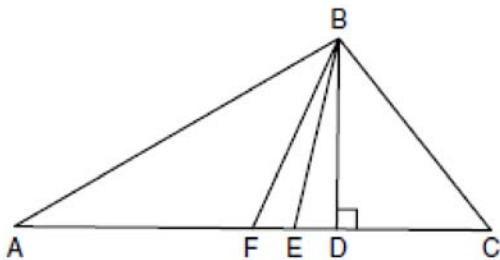

- 1) $\angle FAB \cong \angle ABF$
- 2) $\angle ABF \cong \angle CBD$
- 3) $\overline{CE} \cong \overline{EA}$
- 4) $\overline{CF} \cong \overline{FA}$

69 The figure in the diagram below is a triangular prism.

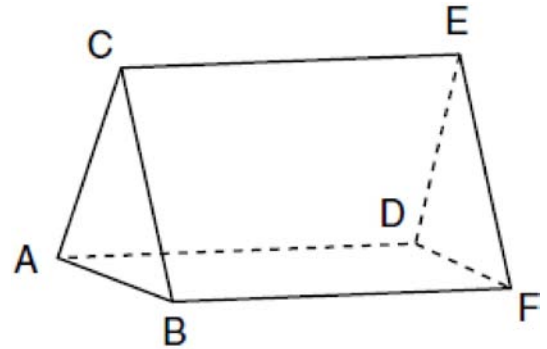

Which statement must be true?

- 1) $\overline{DE} \cong \overline{AB}$
- 2) $\overline{AD} \cong \overline{BC}$
- 3) $\overline{AD} \parallel \overline{CE}$
- 4) $\overline{DE} \parallel \overline{BC}$

70 In the diagram below, which transformation was used to map $\triangle ABC$ to $\triangle A'B'C'$?

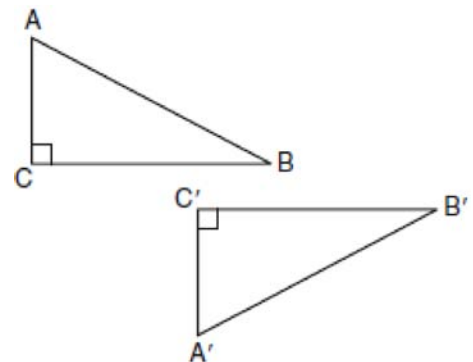

- 1) dilation
- 2) rotation
- 3) reflection
- 4) glide reflection

Geometry Multiple Choice Regents Exam Questions

www.jmap.org

71 Which transformation produces a figure similar but not congruent to the original figure?

- 1) $T_{1,3}$
- 2) $D_{\frac{1}{2}}$
- 3) R_{90°
- 4) $r_{y=x}$

72 Given the equations: $y = x^2 - 6x + 10$

$$y + x = 4$$

What is the solution to the given system of equations?

- 1) (2,3)
- 2) (3,2)
- 3) (2,2) and (1,3)
- 4) (2,2) and (3,1)

73 What is an equation of the line that contains the point (3, -1) and is perpendicular to the line whose equation is $y = -3x + 2$?

- 1) $y = -3x + 8$
- 2) $y = -3x$
- 3) $y = \frac{1}{3}x$
- 4) $y = \frac{1}{3}x - 2$

74 Which equation represents a line parallel to the line whose equation is $2y - 5x = 10$?

- 1) $5y - 2x = 25$
- 2) $5y + 2x = 10$
- 3) $4y - 10x = 12$
- 4) $2y + 10x = 8$

75 Based on the construction below, which statement must be true?

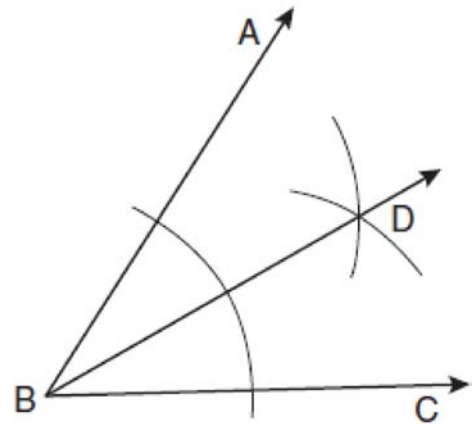

- 1) $m\angle ABD = \frac{1}{2} m\angle CBD$
- 2) $m\angle ABD = m\angle CBD$
- 3) $m\angle ABD = m\angle ABC$
- 4) $m\angle CBD = \frac{1}{2} m\angle ABD$

76 What is the inverse of the statement “If two triangles are not similar, their corresponding angles are not congruent”?

- 1) If two triangles are similar, their corresponding angles are not congruent.
- 2) If corresponding angles of two triangles are not congruent, the triangles are not similar.
- 3) If two triangles are similar, their corresponding angles are congruent.
- 4) If corresponding angles of two triangles are congruent, the triangles are similar.

Geometry Multiple Choice Regents Exam Questions

www.jmap.org

77 Which equation represents the circle whose center is $(-2,3)$ and whose radius is 5?

- 1) $(x-2)^2 + (y+3)^2 = 5$
- 2) $(x+2)^2 + (y-3)^2 = 5$
- 3) $(x+2)^2 + (y-3)^2 = 25$
- 4) $(x-2)^2 + (y+3)^2 = 25$

78 The diagram below illustrates the construction of \overleftrightarrow{PS} parallel to \overleftrightarrow{RQ} through point P .

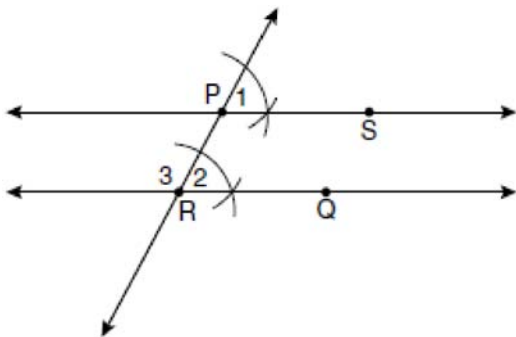

Which statement justifies this construction?

- 1) $m\angle 1 = m\angle 2$
- 2) $m\angle 1 = m\angle 3$
- 3) $\overline{PR} \cong \overline{RQ}$
- 4) $\overline{PS} \cong \overline{RQ}$

79 In $\triangle ABC$, $m\angle A = x$, $m\angle B = 2x + 2$, and $m\angle C = 3x + 4$. What is the value of x ?

- 1) 29
- 2) 31
- 3) 59
- 4) 61

80 In the diagram below of $\triangle ABC$, D is a point on \overline{AB} , $AC = 7$, $AD = 6$, and $BC = 18$.

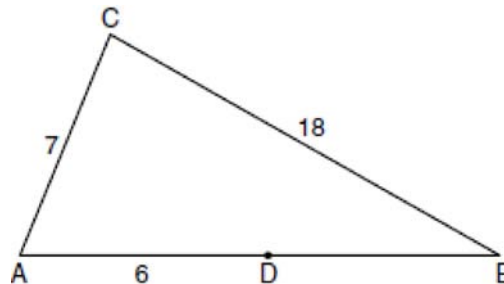

(Not drawn to scale)

The length of \overline{DB} could be

- 1) 5
- 2) 12
- 3) 19
- 4) 25

81 In the diagram below of $\triangle ACT$, D is the midpoint of \overline{AC} , O is the midpoint of \overline{AT} , and G is the midpoint of \overline{CT} .

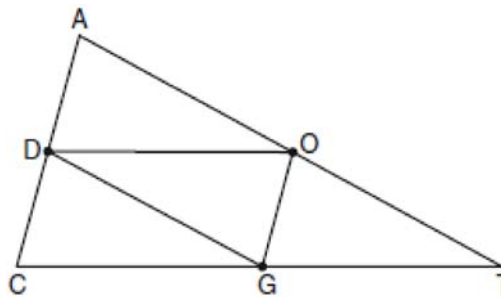

If $AC = 10$, $AT = 18$, and $CT = 22$, what is the perimeter of parallelogram $CDOG$?

- 1) 21
- 2) 25
- 3) 32
- 4) 40

Geometry Multiple Choice Regents Exam Questions

www.jmap.org

- 82 Which graph could be used to find the solution to the following system of equations?

$$y = -x + 2$$

$$y = x^2$$

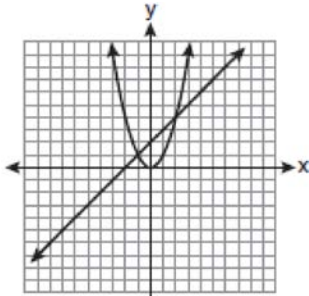

1)

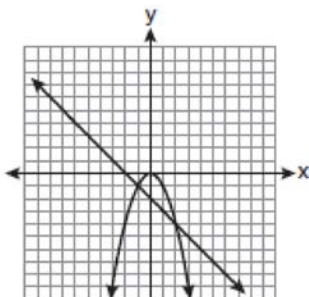

2)

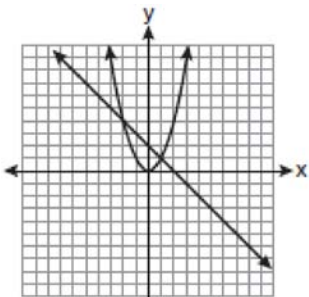

3)

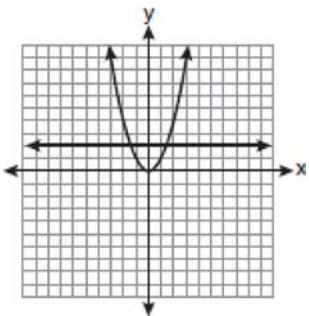

4)

- 83 In three-dimensional space, two planes are parallel and a third plane intersects both of the parallel planes. The intersection of the planes is a

- 1) plane
- 2) point
- 3) pair of parallel lines
- 4) pair of intersecting lines

- 84 How many common tangent lines can be drawn to the two externally tangent circles shown below?

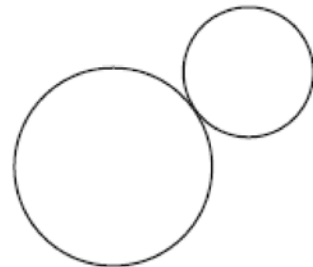

- 1) 1
- 2) 2
- 3) 3
- 4) 4

- 85 Given the system of equations:

$$y = x^2 - 4x$$

$$x = 4$$

The number of points of intersection is

- 1) 1
- 2) 2
- 3) 3
- 4) 0

Geometry Multiple Choice Regents Exam Questions

www.jmap.org

- 86 In the diagram of $\triangle ABC$ below, Jose found centroid P by constructing the three medians. He measured \overline{CF} and found it to be 6 inches.

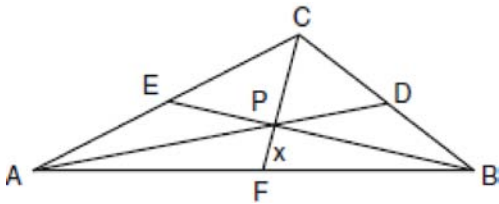

If $PF = x$, which equation can be used to find x ?

- 1) $x + x = 6$
 - 2) $2x + x = 6$
 - 3) $3x + 2x = 6$
 - 4) $x + \frac{2}{3}x = 6$
- 87 Lines j and k intersect at point P . Line m is drawn so that it is perpendicular to lines j and k at point P . Which statement is correct?
- 1) Lines j and k are in perpendicular planes.
 - 2) Line m is in the same plane as lines j and k .
 - 3) Line m is parallel to the plane containing lines j and k .
 - 4) Line m is perpendicular to the plane containing lines j and k .

- 88 What is an equation of the line that passes through the point $(-2, 5)$ and is perpendicular to the line

whose equation is $y = \frac{1}{2}x + 5$?

- 1) $y = 2x + 1$
- 2) $y = -2x + 1$
- 3) $y = 2x + 9$
- 4) $y = -2x - 9$

- 89 The lines $3y + 1 = 6x + 4$ and $2y + 1 = x - 9$ are
- 1) parallel
 - 2) perpendicular
 - 3) the same line
 - 4) neither parallel nor perpendicular

- 90 In the diagram below of trapezoid $RSUT$, $\overline{RS} \parallel \overline{TU}$, X is the midpoint of \overline{RT} , and V is the midpoint of \overline{SU} .

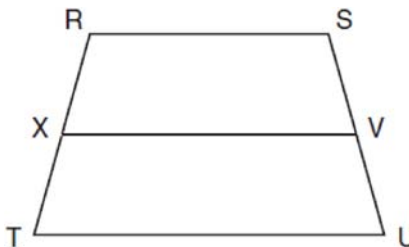

If $RS = 30$ and $XV = 44$, what is the length of \overline{TU} ?

- 1) 37
 - 2) 58
 - 3) 74
 - 4) 118
- 91 Given $\triangle ABC \sim \triangle DEF$ such that $\frac{AB}{DE} = \frac{3}{2}$. Which statement is *not* true?
- 1) $\frac{BC}{EF} = \frac{3}{2}$
 - 2) $\frac{m\angle A}{m\angle D} = \frac{3}{2}$
 - 3) $\frac{\text{area of } \triangle ABC}{\text{area of } \triangle DEF} = \frac{9}{4}$
 - 4) $\frac{\text{perimeter of } \triangle ABC}{\text{perimeter of } \triangle DEF} = \frac{3}{2}$

Geometry Multiple Choice Regents Exam Questions

www.jmap.org

92 Isosceles trapezoid $ABCD$ has diagonals \overline{AC} and \overline{BD} . If $AC = 5x + 13$ and $BD = 11x - 5$, what is the value of x ?

- 1) 28
- 2) $10\frac{3}{4}$
- 3) 3
- 4) $\frac{1}{2}$

93 A quadrilateral whose diagonals bisect each other and are perpendicular is a

- 1) rhombus
- 2) rectangle
- 3) trapezoid
- 4) parallelogram

94 Which equation represents circle K shown in the graph below?

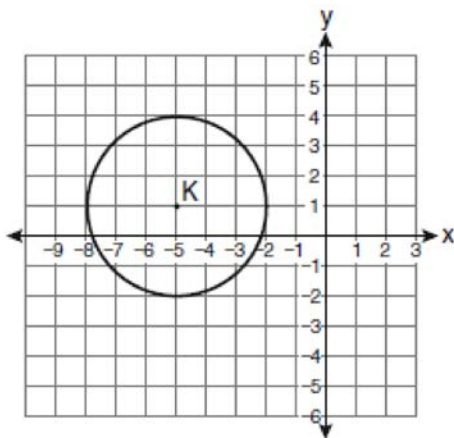

- 1) $(x + 5)^2 + (y - 1)^2 = 3$
- 2) $(x + 5)^2 + (y - 1)^2 = 9$
- 3) $(x - 5)^2 + (y + 1)^2 = 3$
- 4) $(x - 5)^2 + (y + 1)^2 = 9$

95 If the endpoints of \overline{AB} are $A(-4, 5)$ and $B(2, -5)$, what is the length of \overline{AB} ?

- 1) $2\sqrt{34}$
- 2) 2
- 3) $\sqrt{61}$
- 4) 8

96 Based on the diagram below, which statement is true?

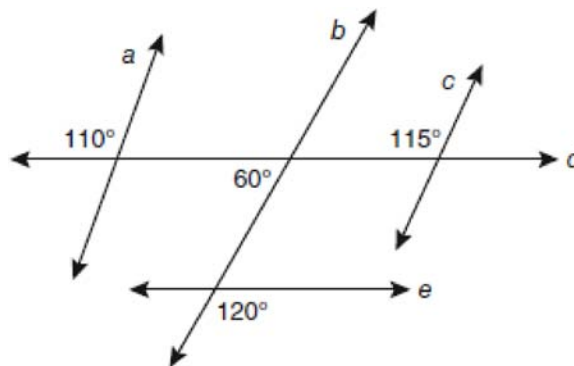

- 1) $a \parallel b$
- 2) $a \parallel c$
- 3) $b \parallel c$
- 4) $d \parallel e$

97 Side \overline{PQ} of $\triangle PQR$ is extended through Q to point T . Which statement is *not* always true?

- 1) $m\angle RQT > m\angle R$
- 2) $m\angle RQT > m\angle P$
- 3) $m\angle RQT = m\angle P + m\angle R$
- 4) $m\angle RQT > m\angle PQR$

Geometry Multiple Choice Regents Exam Questions

www.jmap.org

98 Which set of numbers represents the lengths of the sides of a triangle?

- 1) {5, 18, 13}
- 2) {6, 17, 22}
- 3) {16, 24, 7}
- 4) {26, 8, 15}

99 In the diagram below, \overline{SQ} and \overline{PR} intersect at T , \overline{PQ} is drawn, and $\overline{PS} \parallel \overline{QR}$.

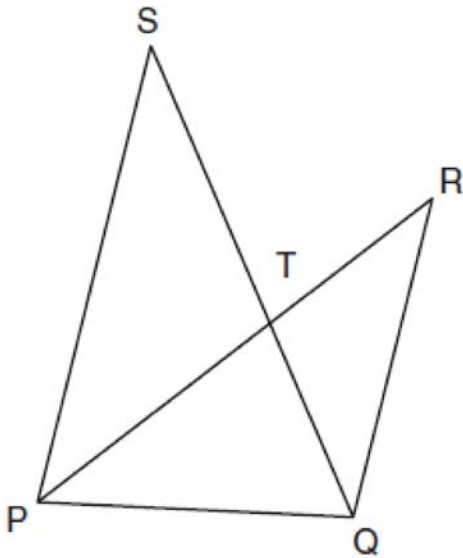

What technique can be used to prove that $\triangle PST \sim \triangle RQT$?

- 1) SAS
- 2) SSS
- 3) ASA
- 4) AA

100 A polygon is transformed according to the rule: $(x, y) \rightarrow (x + 2, y)$. Every point of the polygon moves two units in which direction?

- 1) up
- 2) down
- 3) left
- 4) right

101 Square $LMNO$ is shown in the diagram below.

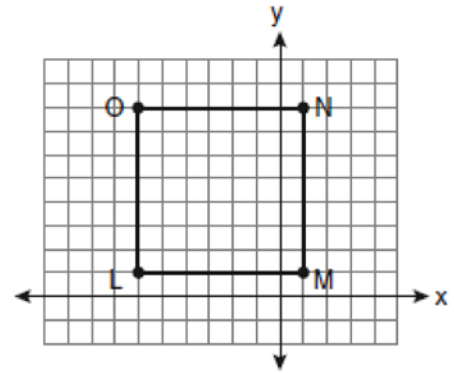

What are the coordinates of the midpoint of diagonal \overline{LN} ?

- 1) $\left(4\frac{1}{2}, -2\frac{1}{2}\right)$
- 2) $\left(-3\frac{1}{2}, 3\frac{1}{2}\right)$
- 3) $\left(-2\frac{1}{2}, 3\frac{1}{2}\right)$
- 4) $\left(-2\frac{1}{2}, 4\frac{1}{2}\right)$

Geometry Multiple Choice Regents Exam Questions

www.jmap.org

- 102 In the diagram below of parallelogram $STUV$, $SV = x + 3$, $VU = 2x - 1$, and $TU = 4x - 3$.

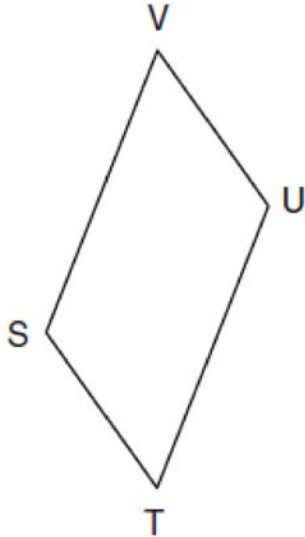

What is the length of \overline{SV} ?

- 1) 5
- 2) 2
- 3) 7
- 4) 4

- 103 In the diagram of circle O below, chord \overline{AB} intersects chord \overline{CD} at E , $DE = 2x + 8$, $EC = 3$, $AE = 4x - 3$, and $EB = 4$.

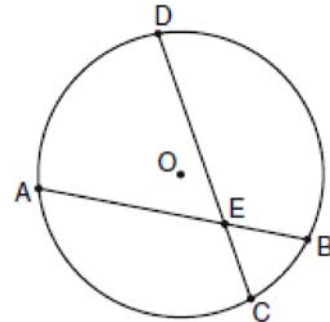

What is the value of x ?

- 1) 1
- 2) 3.6
- 3) 5
- 4) 10.25

- 104 The diagram below shows the construction of the bisector of $\angle ABC$.

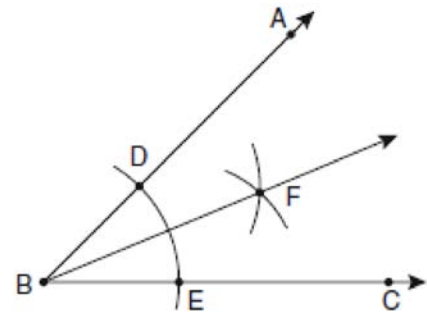

Which statement is *not* true?

- 1) $m\angle EBF = \frac{1}{2} m\angle ABC$
- 2) $m\angle DBF = \frac{1}{2} m\angle ABC$
- 3) $m\angle EBF = m\angle ABC$
- 4) $m\angle DBF = m\angle EBF$

Geometry Multiple Choice Regents Exam Questions

www.jmap.org

- 105 The pentagon in the diagram below is formed by five rays.

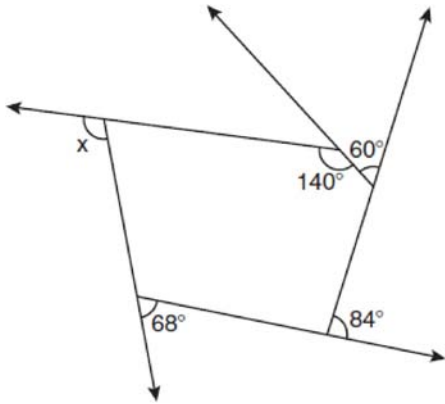

What is the degree measure of angle x ?

- 1) 72
 - 2) 96
 - 3) 108
 - 4) 112
- 106 Point P is on line m . What is the total number of planes that are perpendicular to line m and pass through point P ?
- 1) 1
 - 2) 2
 - 3) 0
 - 4) infinite

- 107 In the diagram below, \overline{PS} is a tangent to circle O at point S , \overline{PQR} is a secant, $PS = x$, $PQ = 3$, and $PR = x + 18$.

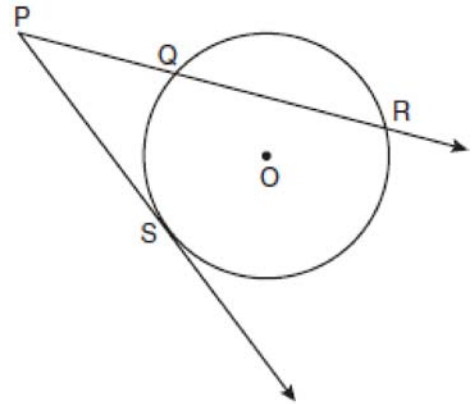

(Not drawn to scale)

What is the length of \overline{PS} ?

- 1) 6
 - 2) 9
 - 3) 3
 - 4) 27
- 108 What is the image of point $A(4,2)$ after the composition of transformations defined by $R_{90^\circ} \circ r_{y=x}$?
- 1) $(-4,2)$
 - 2) $(4,-2)$
 - 3) $(-4,-2)$
 - 4) $(2,-4)$

Geometry Multiple Choice Regents Exam Questions

www.jmap.org

- 109 Which expression best describes the transformation shown in the diagram below?

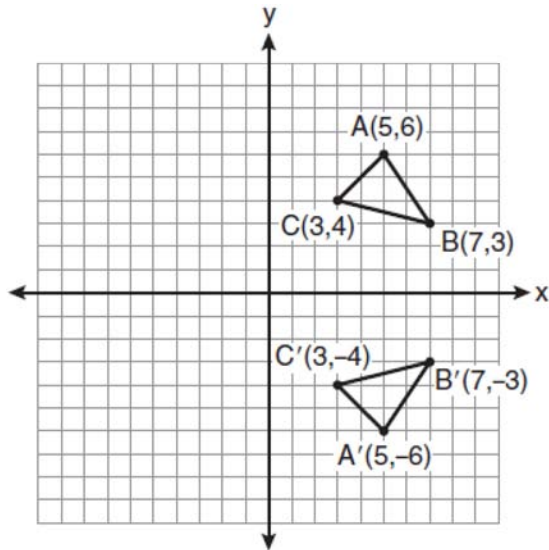

- 1) same orientation; reflection
 - 2) opposite orientation; reflection
 - 3) same orientation; translation
 - 4) opposite orientation; translation
- 110 In $\triangle ABC$, point D is on \overline{AB} , and point E is on \overline{BC} such that $\overline{DE} \parallel \overline{AC}$. If $DB = 2$, $DA = 7$, and $DE = 3$, what is the length of \overline{AC} ?
- 1) 8
 - 2) 9
 - 3) 10.5
 - 4) 13.5

- 111 Which geometric principle is used to justify the construction below?

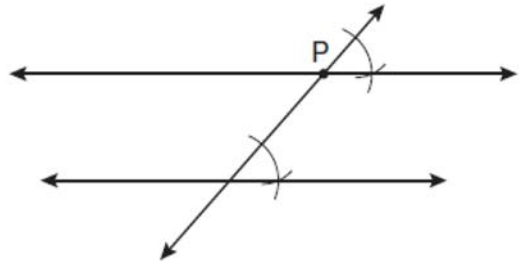

- 1) A line perpendicular to one of two parallel lines is perpendicular to the other.
 - 2) Two lines are perpendicular if they intersect to form congruent adjacent angles.
 - 3) When two lines are intersected by a transversal and alternate interior angles are congruent, the lines are parallel.
 - 4) When two lines are intersected by a transversal and the corresponding angles are congruent, the lines are parallel.
- 112 What is the measure of an interior angle of a regular octagon?

- 1) 45°
- 2) 60°
- 3) 120°
- 4) 135°

Geometry 2 Point Regents Exam Questions

- 113 Write a statement that is logically equivalent to the statement “If two sides of a triangle are congruent, the angles opposite those sides are congruent.” Identify the new statement as the converse, inverse, or contrapositive of the original statement.

- 114 In the diagram below of $\triangle ABC$ with side \overline{AC} extended through D , $m\angle A = 37$ and $m\angle BCD = 117$. Which side of $\triangle ABC$ is the longest side? Justify your answer.

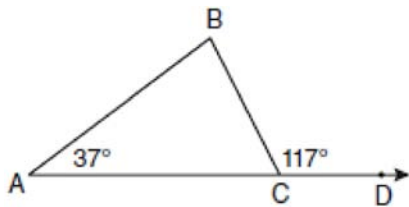

(Not drawn to scale)

- 115 In the diagram below of $\triangle TEM$, medians \overline{TB} , \overline{EC} , and \overline{MA} intersect at D , and $TB = 9$. Find the length of \overline{TD} .

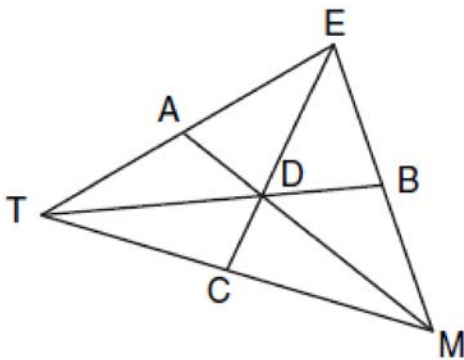

- 116 In the diagram of $\triangle ABC$ below, $AB = 10$, $BC = 14$, and $AC = 16$. Find the perimeter of the triangle formed by connecting the midpoints of the sides of $\triangle ABC$.

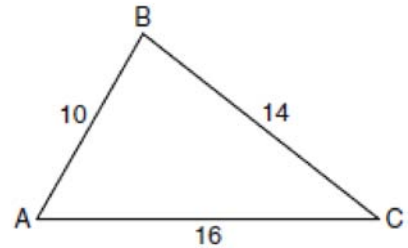

- 117 A regular pyramid with a square base is shown in the diagram below.

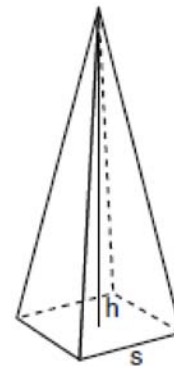

A side, s , of the base of the pyramid is 12 meters, and the height, h , is 42 meters. What is the volume of the pyramid in cubic meters?

- 118 The degree measures of the angles of $\triangle ABC$ are represented by x , $3x$, and $5x - 54$. Find the value of x .

Geometry 2 Point Regents Exam Questions

www.jmap.org

119 Write an equation of the line that passes through the point $(6, -5)$ and is parallel to the line whose equation is $2x - 3y = 11$.

120 The vertices of $\triangle ABC$ are $A(3, 2)$, $B(6, 1)$, and $C(4, 6)$. Identify and graph a transformation of $\triangle ABC$ such that its image, $\triangle A'B'C'$, results in $\overline{AB} \parallel \overline{A'B'}$.

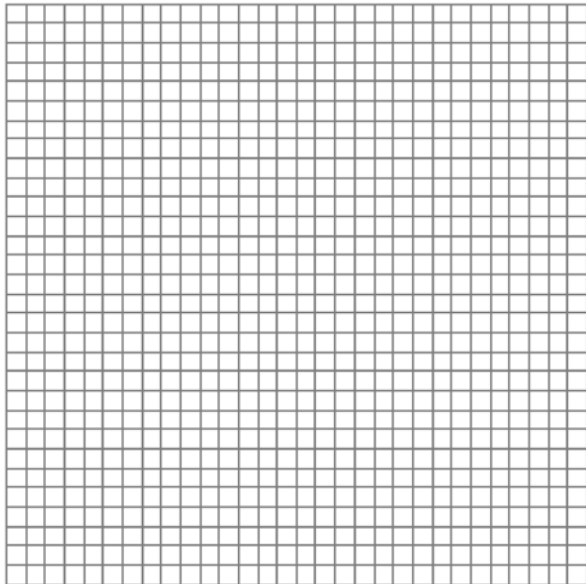

121 The volume of a cylinder is $12,566.4 \text{ cm}^3$. The height of the cylinder is 8 cm. Find the radius of the cylinder to the *nearest tenth of a centimeter*.

122 In $\triangle RST$, $m\angle RST = 46$ and $\overline{RS} \cong \overline{ST}$. Find $m\angle STR$.

123 In the diagram below of right triangle ACB , altitude \overline{CD} intersects \overline{AB} at D . If $AD = 3$ and $DB = 4$, find the length of \overline{CD} in simplest radical form.

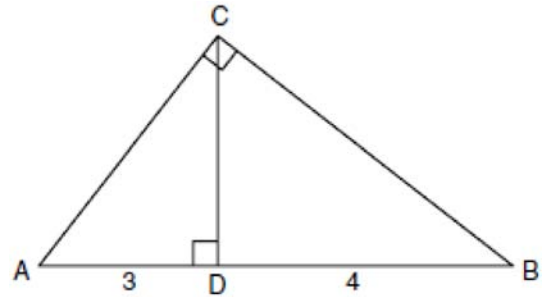

124 In the diagram below of isosceles trapezoid $DEFG$, $\overline{DE} \parallel \overline{GF}$, $DE = 4x - 2$, $EF = 3x + 2$, $FG = 5x - 3$, and $GD = 2x + 5$. Find the value of x .

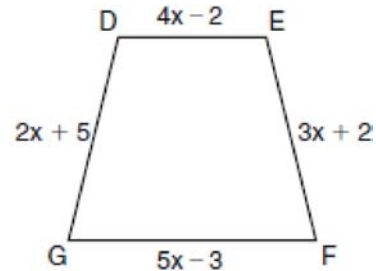

125 Using a compass and straightedge, and \overline{AB} below, construct an equilateral triangle with all sides congruent to \overline{AB} . [Leave all construction marks.]



Geometry 2 Point Regents Exam Questions

www.jmap.org

126 Tim has a rectangular prism with a length of 10 centimeters, a width of 2 centimeters, and an unknown height. He needs to build another rectangular prism with a length of 5 centimeters and the same height as the original prism. The volume of the two prisms will be the same. Find the width, in centimeters, of the new prism.

127 Find an equation of the line passing through the point (5,4) and parallel to the line whose equation is $2x + y = 3$.

128 The endpoints of \overline{PQ} are $P(-3, 1)$ and $Q(4, 25)$. Find the length of \overline{PQ} .

129 Using a compass and straightedge, construct the angle bisector of $\angle ABC$ shown below. [Leave all construction marks.]

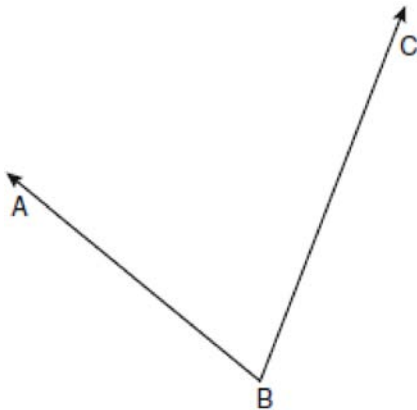

130 Using a compass and straightedge, construct a line that passes through point P and is perpendicular to line m . [Leave all construction marks.]

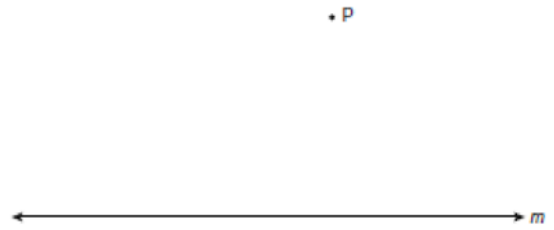

131 In the diagram below, $\triangle ABC \sim \triangle EFG$, $m\angle C = 4x + 30$, and $m\angle G = 5x + 10$. Determine the value of x .

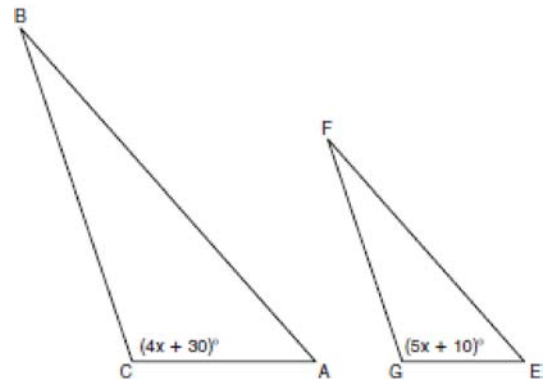

132 Given: Two is an even integer or three is an even integer.
Determine the truth value of this disjunction.
Justify your answer.

Geometry 2 Point Regents Exam Questions

www.jmap.org

- 133 In the diagram below of circle C , \overline{QR} is a diameter, and $Q(1,8)$ and $C(3.5,2)$ are points on a coordinate plane. Find and state the coordinates of point R .

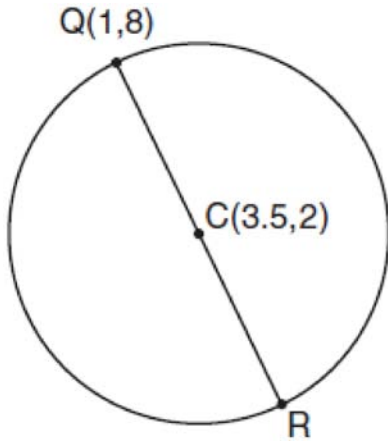

- 135 In the diagram below of $\triangle ACD$, E is a point on \overline{AD} and B is a point on \overline{AC} , such that $\overline{EB} \parallel \overline{DC}$. If $\overline{AE} = 3$, $\overline{ED} = 6$, and $\overline{DC} = 15$, find the length of \overline{EB} .

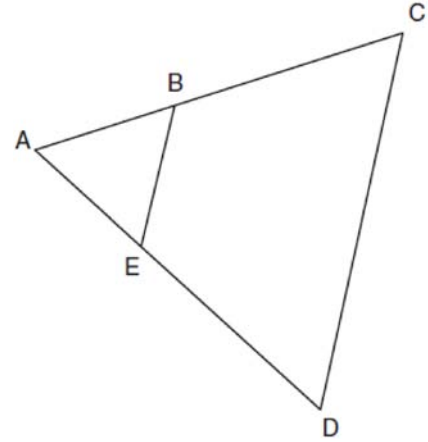

- 134 Using a compass and straightedge, construct the bisector of the angle shown below. [*Leave all construction marks.*]

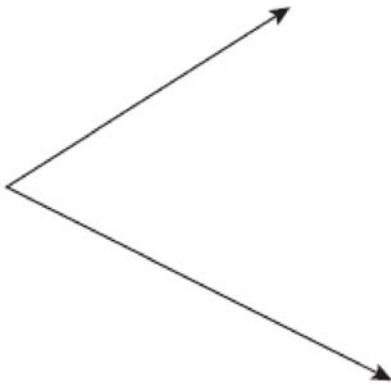

Geometry 2 Point Regents Exam Questions

www.jmap.org

- 136 The length of \overline{AB} is 3 inches. On the diagram below, sketch the points that are equidistant from A and B and sketch the points that are 2 inches from A . Label with an **X** all points that satisfy both conditions.



Geometry 4 Point Regents Exam Questions

- 137 A city is planning to build a new park. The park must be equidistant from school A at $(3, 3)$ and school B at $(3, -5)$. The park also must be exactly 5 miles from the center of town, which is located at the origin on the coordinate graph. Each unit on the graph represents 1 mile. On the set of axes below, sketch the compound loci and label with an **X** all possible locations for the new park.

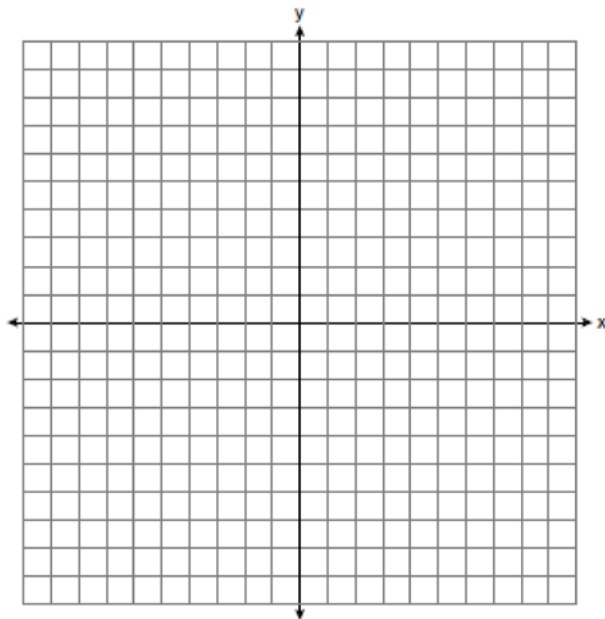

- 138 In $\triangle KLM$, $m\angle K = 36$ and $KM = 5$. The transformation D_2 is performed on $\triangle KLM$ to form $\triangle K'L'M'$. Find $m\angle K'$. Justify your answer. Find the length of $K'M'$. Justify your answer.

- 139 On the grid below, graph the points that are equidistant from both the x and y axes and the points that are 5 units from the origin. Label with an **X** all points that satisfy both conditions.

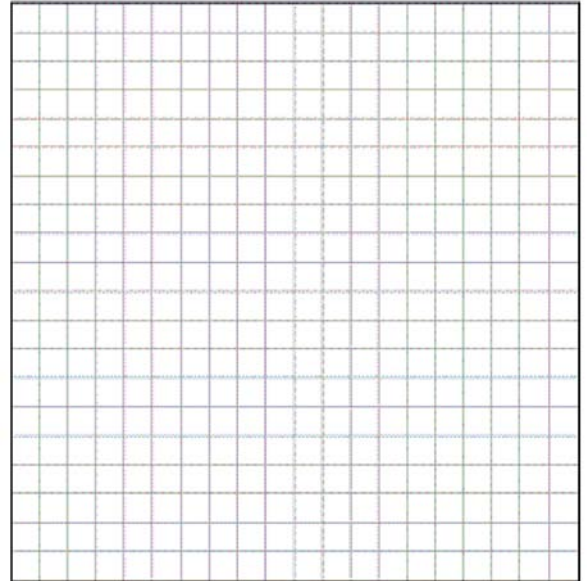

- 140 In the diagram below, circles X and Y have two tangents drawn to them from external point T . The points of tangency are $C, A, S,$ and E . The ratio of \overline{TA} to \overline{AC} is $1:3$. If $TS = 24$, find the length of \overline{SE} .

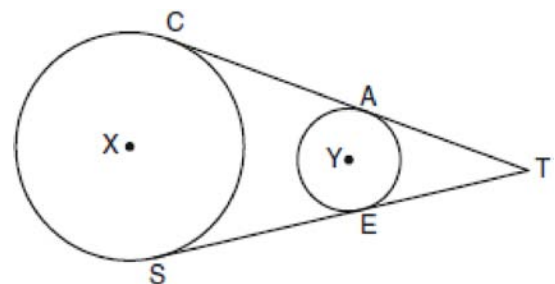

(Not drawn to scale)

Geometry 4 Point Regents Exam Questions

www.jmap.org

141 Given: \overline{JKLM} is a parallelogram.

$$\overline{JM} \cong \overline{LN}$$

$$\angle LMN \cong \angle LNM$$

Prove: \overline{JKLM} is a rhombus.

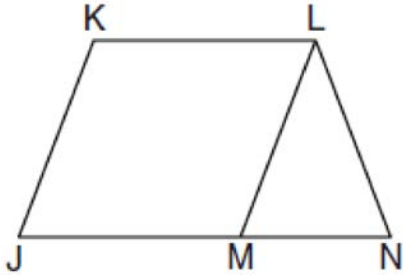

142 The coordinates of the vertices of parallelogram $ABCD$ are $A(-2,2)$, $B(3,5)$, $C(4,2)$, and $D(-1,-1)$. State the coordinates of the vertices of parallelogram $A''B''C''D''$ that result from the transformation $r_{y\text{-axis}} \circ T_{2,-3}$. [The use of the set of axes below is optional.]

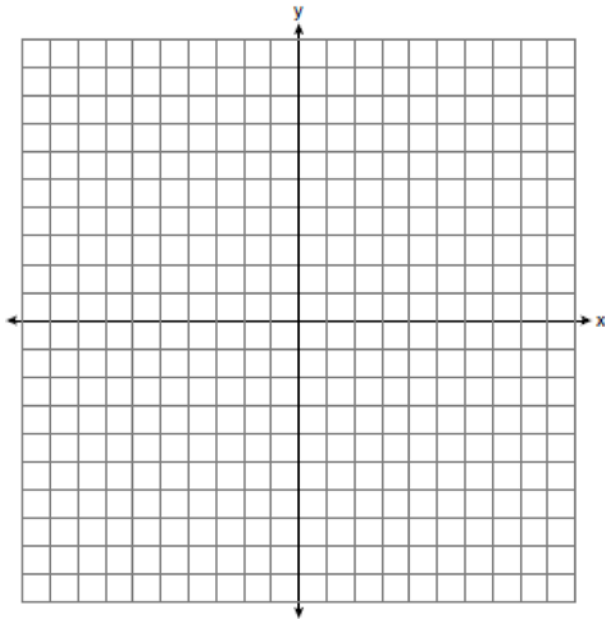

143 Write an equation of the perpendicular bisector of the line segment whose endpoints are $(-1,1)$ and $(7,-5)$. [The use of the grid below is optional]

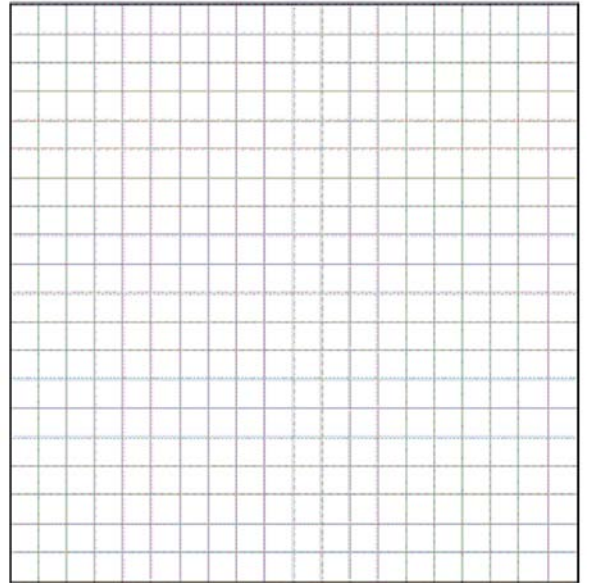

144 In the diagram below of circle O , chords \overline{DF} , \overline{DE} , \overline{FG} , and \overline{EG} are drawn such that $m\widehat{DF} : m\widehat{FE} : m\widehat{EG} : m\widehat{GD} = 5 : 2 : 1 : 7$. Identify one pair of inscribed angles that are congruent to each other and give their measure.

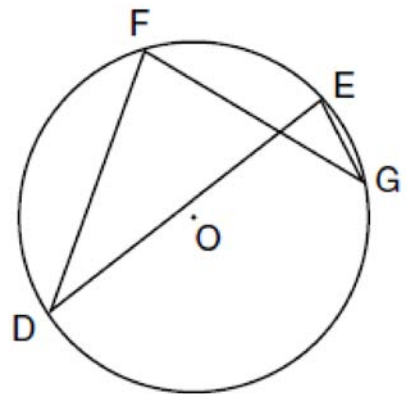

Geometry 4 Point Regents Exam Questions

www.jmap.org

- 145 Triangle ABC has coordinates $A(-6,2)$, $B(-3,6)$, and $C(5,0)$. Find the perimeter of the triangle. Express your answer in simplest radical form. [The use of the grid below is optional.]

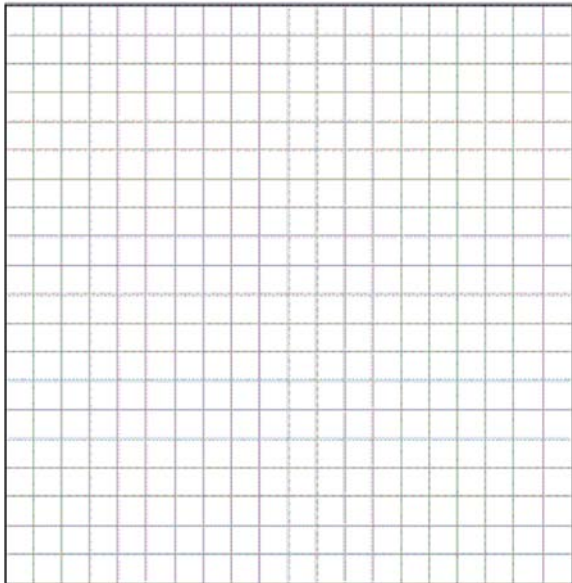

- 146 Triangle DEG has the coordinates $D(1,1)$, $E(5,1)$, and $G(5,4)$. Triangle DEG is rotated 90° about the origin to form $\triangle D'E'G'$. On the grid below, graph and label $\triangle DEG$ and $\triangle D'E'G'$. State the coordinates of the vertices D' , E' , and G' . Justify that this transformation preserves distance.

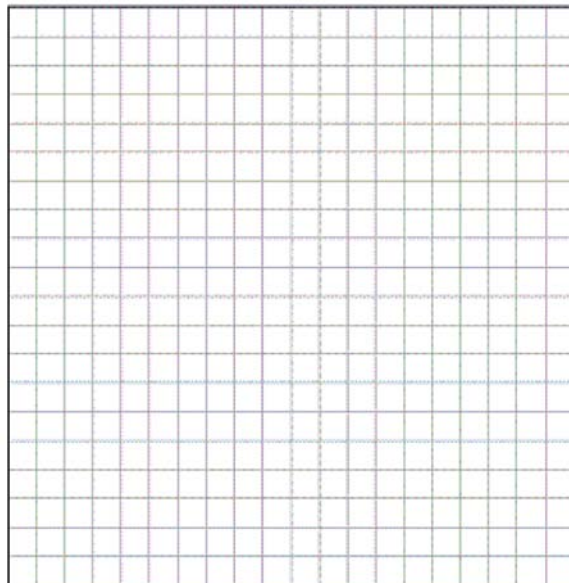

Geometry 4 Point Regents Exam Questions

www.jmap.org

- 147 On the set of axes below, graph and label $\triangle DEF$ with vertices at $D(-4, -4)$, $E(-2, 2)$, and $F(8, -2)$. If G is the midpoint of \overline{EF} and H is the midpoint of \overline{DF} , state the coordinates of G and H and label \overline{GH} . Explain why $\overline{GH} \parallel \overline{DE}$.

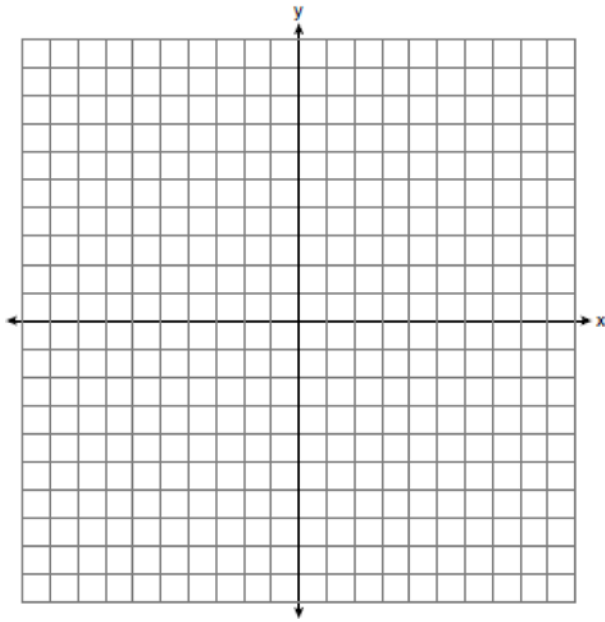

- 148 On the set of axes below, sketch the points that are 5 units from the origin and sketch the points that are 2 units from the line $y = 3$. Label with an **X** all points that satisfy both conditions.

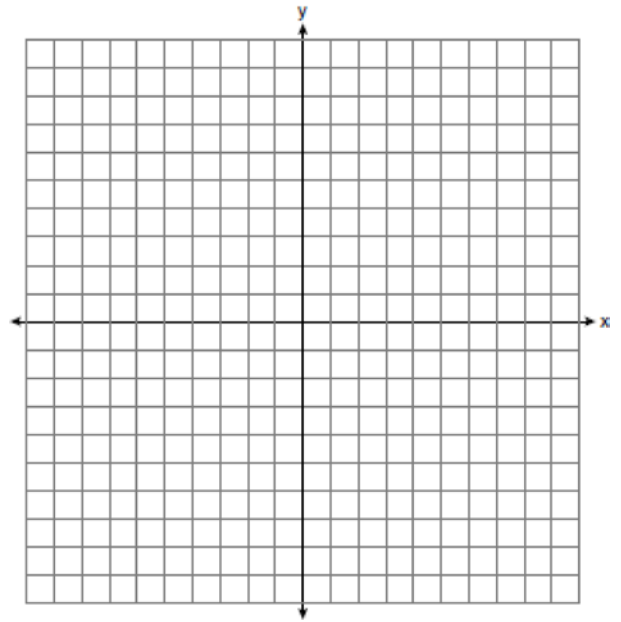

Geometry 6 Point Regents Exam Questions

- 149 In the diagram below, quadrilateral $ABCD$ is inscribed in circle O , $\overline{AB} \parallel \overline{DC}$, and diagonals \overline{AC} and \overline{BD} are drawn. Prove that $\triangle ACD \cong \triangle BDC$.

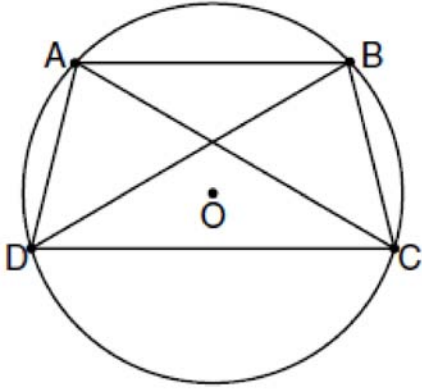

- 150 Given: Quadrilateral $ABCD$, diagonal \overline{AFEC} , $\overline{AE} \cong \overline{FC}$, $\overline{BF} \perp \overline{AC}$, $\overline{DE} \perp \overline{AC}$, $\angle 1 \cong \angle 2$
 Prove: $ABCD$ is a parallelogram.

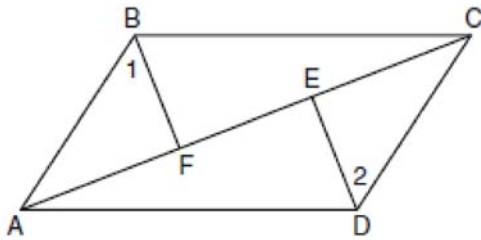

- 151 On the set of axes below, solve the following system of equations graphically for all values of x and y .

$$y = (x - 2)^2 + 4$$

$$4x + 2y = 14$$

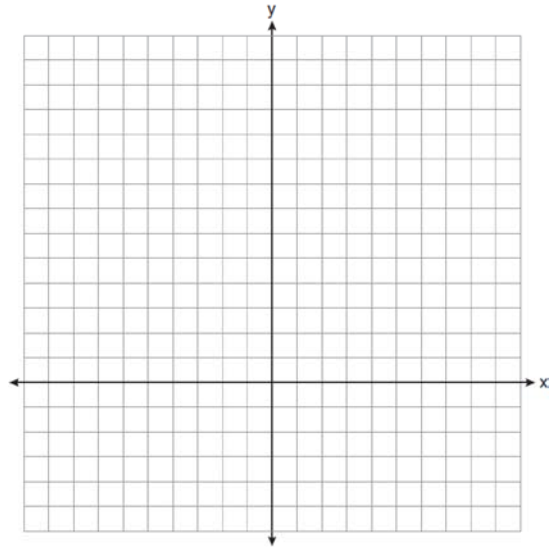

- 152 Given: $\triangle ABC$ and $\triangle EDC$, C is the midpoint of \overline{BD} and \overline{AE}
 Prove: $\overline{AB} \parallel \overline{DE}$

