

JEFFERSON MATH PROJECT

REGENTS BY CHAPTER

736 NY Regents Exam Questions from
June 1999 to January 2008 Sorted by Prentice Hall Chapter
ALGEBRA

www.jmap.org



Dear Sir

I have to acknowledge the receipt of your favor of May 14. in which you mention that you have finished the 6. first books of Euclid, plane trigonometry, surveying & algebra and ask whether I think a further pursuit of that branch of science would be useful to you. there are some propositions in the latter books of Euclid, & some of Archimedes, which are useful, & I have no doubt you have been made acquainted with them. trigonometry, so far as this, is most valuable to every man, there is scarcely a day in which he will not resort to it for some of the purposes of common life. the science of calculation also is indispensable as far as the extraction of the square & cube roots; Algebra as far as the quadratic equation & the use of logarithms are often of value in ordinary cases: but all beyond these is but a luxury; a delicious luxury indeed; but not to be indulged in by one who is to have a profession to follow for his subsistence. in this light I view the conic sections, curves of the higher orders, perhaps even spherical trigonometry, Algebraical operations beyond the 2d dimension, and fluxions.

Letter from Thomas Jefferson to William G. Munford, Monticello, June 18, 1799.

TABLE OF CONTENTS

ALGEBRA

	<u>PRENTICE HALL CHAPTER</u>	<u>QUESTION NUMBER</u>
CH1	Tools of Algebra	1-123
CH2	Functions and Their Graphs	124-147
CH3	Algebraic Concepts and Simple Equations	148-200
CH4	Equations and Inequalities	201-303
CH5	Graphing and Writing Linear Equations	304-363
CH6	Systems of Equations and Inequalities	364-426
CH7	Quadratic Equations and Functions	427-448
CH8	Exponents and Exponential Functions	449-497
CH9	Right Triangles and Radical Expressions	498-591
CH10	Polynomials	592-656
CH11	Rational Expressions and Functions	657-736

CHAPTER 1-1

CENTRAL TENDENCY

1. 080501a, P.I. A.S.4
The weights of all the students in grade 9 are arranged from least to greatest. Which statistical measure separates the top half of this set of data from the bottom half?

[A] median [B] mode
[C] mean [D] average

2. 080402a, P.I. 6.S.5
Rosario and Enrique are in the same mathematics class. On the first five tests, Rosario received scores of 78, 77, 64, 86, and 70. Enrique received scores of 90, 61, 79, 73, and 87. How much higher was Enrique's average than Rosario's average?

[A] 3 points [B] 4 points
[C] 2 points [D] 15 points

3. 080008a, P.I. A2.S.3
On an English examination, two students received scores of 90, five students received 85, seven students received 75, and one student received 55. The average score on this examination was

[A] 75 [B] 76 [C] 79 [D] 77

4. 080535a, P.I. 6.S.5
Seth bought a used car that had been driven 20,000 miles. After he owned the car for 2 years, the total mileage of the car was 49,400. Find the average number of miles he drove *each month* during those 2 years.

5. 010005a, P.I. 6.S.5
What was the median high temperature in Middletown during the 7-day period shown in the table below?

Daily High Temperature in Middletown	
Day	Temperature (°F)
Sunday	68
Monday	73
Tuesday	73
Wednesday	75
Thursday	69
Friday	67
Saturday	63

[A] 73 [B] 70 [C] 69 [D] 75

6. 060637a, P.I. 6.S.5
Sara's test scores in mathematics were 64, 80, 88, 78, 60, 92, 84, 76, 86, 78, 72, and 90. Determine the mean, the median, and the mode of Sara's test scores.

7. 080608a, P.I. 6.S.5
The accompanying graph shows the high temperatures in Elmira, New York, for a 5-day period in January.

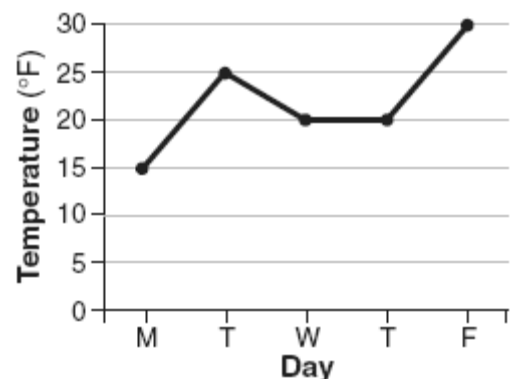

Which statement describes the data?

[A] median = mean [B] mean = mode
[C] mean < mode [D] median = mode

8. 010118a, P.I. 6.S.5
From January 3 to January 7, Buffalo recorded the following daily high temperatures: 5° , 7° , 6° , 5° , and 7° . Which statement about the temperatures is true?
[A] median = mode [B] mean = median
[C] mean = mode [D] mean < median
9. 010315a, P.I. 6.S.5
The ages of five children in a family are 3, 3, 5, 8, and 18. Which statement is true for this group of data?
[A] median > mean [B] mode > mean
[C] median = mode [D] mean > median
10. 010618a, P.I. 6.S.5
Melissa's test scores are 75, 83, and 75. Which statement is true about this set of data?
[A] mean < mode [B] mode < median
[C] mode = median [D] mean = median
11. 010321b, P.I. A.S.4
Two social studies classes took the same current events examination that was scored on the basis of 100 points. Mr. Wong's class had a median score of 78 and a range of 4 points, while Ms. Rizzo's class had a median score of 78 and a range of 22 points. Explain how these classes could have the same median score while having very different ranges.
14. 010432a, P.I. A.A.6
TOP Electronics is a small business with five employees. The mean (average) weekly salary for the five employees is \$360. If the weekly salaries of four of the employees are \$340, \$340, \$345, and \$425, what is the salary of the fifth employee?
15. 060204a, P.I. A.A.6
During each marking period, there are five tests. If Vanita needs a 65 average to pass this marking period and her first four grades are 60, 72, 55, and 80, what is the *lowest* score she can earn on the last test to have a passing average?
[A] 80 [B] 58 [C] 65 [D] 100
16. 080110a, P.I. A.A.6
The exact average of a set of six test scores is 92. Five of these scores are 90, 98, 96, 94, and 85. What is the other test score?
[A] 86 [B] 91 [C] 89 [D] 92
17. 010230a, P.I. A.A.6
The students in Woodland High School's meteorology class measured the noon temperature every schoolday for a week. Their readings for the first 4 days were Monday, 56° ; Tuesday, 72° ; Wednesday, 67° ; and Thursday, 61° . If the mean (average) temperature for the 5 days was exactly 63° , what was the temperature on Friday?

AVERAGE KNOWN WITH MISSING DATA

12. 069929a, P.I. A.A.6
The mean (average) weight of three dogs is 38 pounds. One of the dogs, Sparky, weighs 46 pounds. The other two dogs, Eddie and Sandy, have the same weight. Find Eddie's weight.
13. 089913a, P.I. A.A.6
If 6 and x have the same mean (average) as 2, 4, and 24, what is the value of x ?
[A] 14 [B] 5 [C] 10 [D] 36
18. 060017a, P.I. A.A.6
For five algebra examinations, Maria has an average of 88. What must she score on the sixth test to bring her average up to exactly 90?
[A] 92 [B] 98 [C] 100 [D] 94

19. 010026a, P.I. A.A.6
Judy needs a mean (average) score of 86 on four tests to earn a midterm grade of B. If the mean of her scores for the first three tests was 83, what is the *lowest* score on a 100-point scale that she can receive on the fourth test to have a midterm grade of B?

20. 060703a, P.I. A.A.6
In his first three years coaching baseball at High Ridge High School, Coach Batty's team won 7 games the first year, 16 games the second year, and 4 games the third year. How many games does the team need to win in the fourth year so that the coach's average will be 10 wins per year?

- [A] 13 [B] 3 [C] 9 [D] 10

21. 060438a, P.I. A.A.6
On the first six tests in her social studies course, Jerelyn's scores were 92, 78, 86, 92, 95, and 91. Determine the median and the mode of her scores. If Jerelyn took a seventh test and raised the mean of her scores exactly 1 point, what was her score on the seventh test?

22. 080227a, P.I. A.A.6
Tamika could not remember her scores from five mathematics tests. She did remember that the mean (average) was exactly 80, the median was 81, and the mode was 88. If all her scores were integers with 100 the highest score possible and 0 the lowest score possible, what was the *lowest* score she could have received on any one test?

23. 060738a, P.I. A.A.6
Angelo, Brandon, and Carl work in the same office. Angelo's age is 4 years more than twice Carl's age. Brandon is 5 years younger than Carl. The average of the three ages is 41. Find the age of *each* of the men.

FREQUENCY HISTOGRAMS, BAR GRAPHS AND TABLES

24. 080437a, P.I. A.S.5
The following set of data represents the scores on a mathematics quiz:
58, 79, 81, 99, 68, 92, 76, 84, 53, 57, 81, 91, 77, 50, 65, 57, 51, 72, 84, 89

Complete the frequency table below and, on the accompanying grid, draw and label a frequency histogram of these scores.

Mathematics Quiz Scores

Interval	Tally	Frequency
50–59		
60–69		
70–79		
80–89		
90–99		

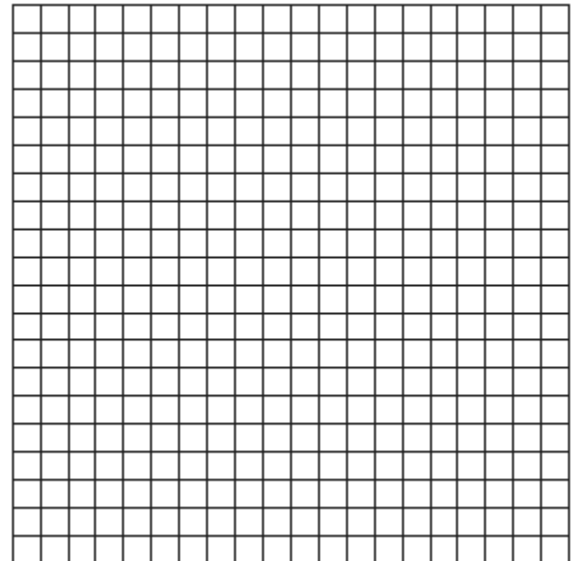

25. 060033a, P.I. A.S.5
The scores on a mathematics test were 70, 55, 61, 80, 85, 72, 65, 40, 74, 68, and 84. Complete the accompanying table, and use the table to construct a frequency histogram for these scores.

Score	Tally	Frequency
40–49		
50–59		
60–69		
70–79		
80–89		

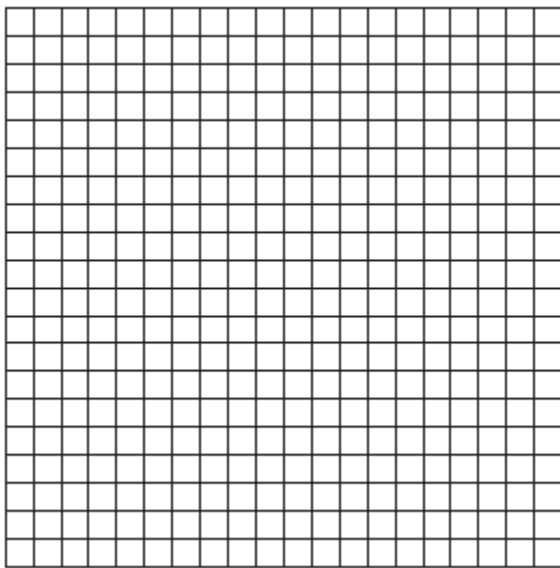

26. 010504a, P.I. A.S.9
The accompanying histogram shows the heights of the students in Kyra's health class.

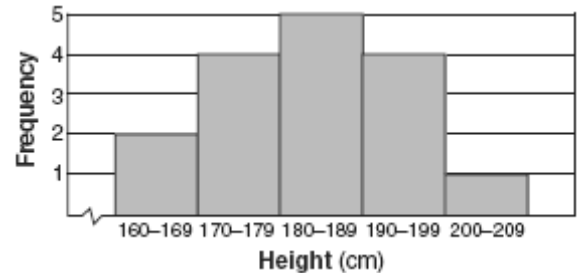

What is the total number of students in the class?

- [A] 15 [B] 16 [C] 5 [D] 209

27. 010334a, P.I. A.S.5
Sarah's mathematics grades for one marking period were 85, 72, 97, 81, 77, 93, 100, 75, 86, 70, 96, and 80.
a Complete the tally sheet and frequency table below, and construct and label a frequency histogram for Sarah's grades using the accompanying grid.

Interval (grades)	Tally	Frequency
61–70		
71–80		
81–90		
91–100		

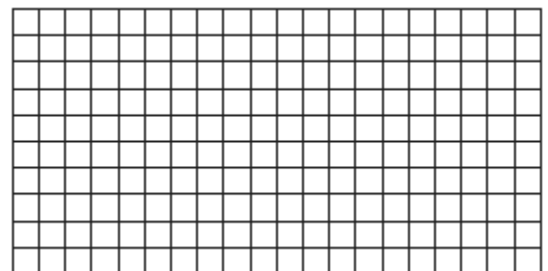

- b* Which interval contains the 75th percentile (upper quartile)?

28. 010032a, P.I. A.S.5

In the time trials for the 400-meter run at the state sectionals, the 15 runners recorded the times shown in the table below.

400-Meter Run	
Time (sec)	Frequency
50.0–50.9	
51.0–51.9	II
52.0–52.9	
53.0–53.9	III
54.0–54.9	IIII

a Using the data from the frequency column, draw a frequency histogram on the grid provided below.

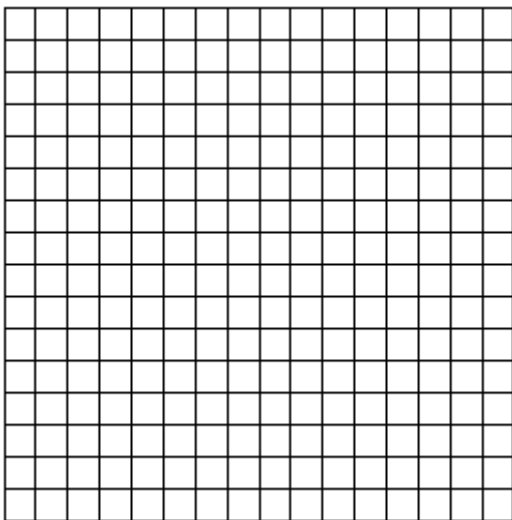

b What percent of the runners completed the time trial between 52.0 and 53.9 seconds?

29. 060401a, P.I. A.S.9

The test scores for 10 students in Ms. Sampson's homeroom were 61, 67, 81, 83, 87, 88, 89, 90, 98, and 100. Which frequency table is accurate for this set of data?

[A]

Interval	Frequency
61–70	2
71–80	0
81–90	8
91–100	10

[B]

Interval	Frequency
61–70	2
71–80	2
81–90	7
91–100	10

[C]

Interval	Frequency
61–70	2
71–80	0
81–90	6
91–100	2

[D]

Interval	Frequency
61–70	2
71–80	2
81–90	8
91–100	10

30. fall0737ia, P.I. A.S.4

The values of 11 houses on Washington St. are shown in the table below.

Value per House	Number of Houses
\$100,000	1
\$175,000	5
\$200,000	4
\$700,000	1

Find the mean value of these houses in dollars. Find the median value of these houses in dollars. State which measure of central tendency, the mean or the median, *best* represents the values of these 11 houses. Justify your answer.

31. 060507b, P.I. A2.S.3

What is the mean of the data in the accompanying table?

Scores (x_i)	Frequency (f_i)
25	3
20	2
11	5
10	4

- [A] 15 [B] 16 [C] 11 [D] 14.5

32. 010807b, P.I. A2.S.3

Mayken collected data about the size of the honors classes in her school building. This set of data is shown in the accompanying table.

Class Size	Frequency
8	1
10	3
14	2

Which statement about the range of this sample is true?

- [A] range > mean
[B] range < standard deviation
[C] range < mean [D] range = mean

NY LESSON 9

33. 080134a, P.I. A.S.5

The following data consists of the weights, in pounds, of 30 adults:

195, 206, 100, 98, 150, 210, 195, 106, 195,
168, 180, 212, 104, 195, 100,
216, 195, 209, 112, 99, 206, 116, 195, 100,
142, 100, 135, 98, 160, 155

Using the data, complete the accompanying cumulative frequency table and construct a cumulative frequency histogram on the grid below.

Interval	Frequency	Cumulative Frequency
51–100		
101–150		
151–200		
201–250		

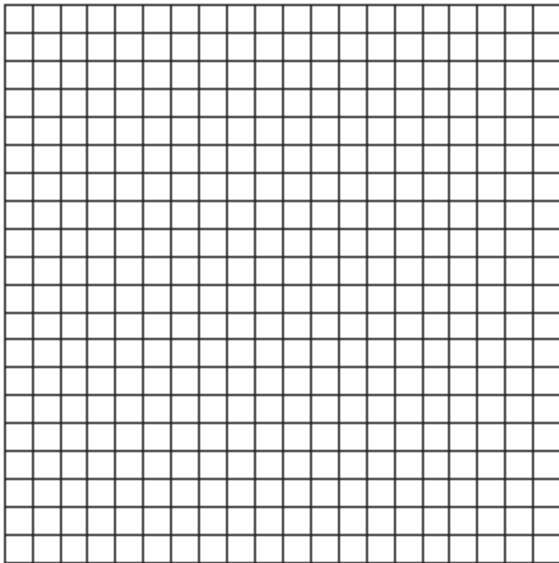

34. 010739a, P.I. A.S.5

The accompanying table shows the weights, in pounds, for the students in an algebra class. Using the data, complete the cumulative frequency table and construct a cumulative frequency histogram on the grid below.

Interval	Frequency	Cumulative Frequency
91–100	6	
101–110	3	
111–120	0	
121–130	3	
131–140	0	
141–150	2	
151–160	2	

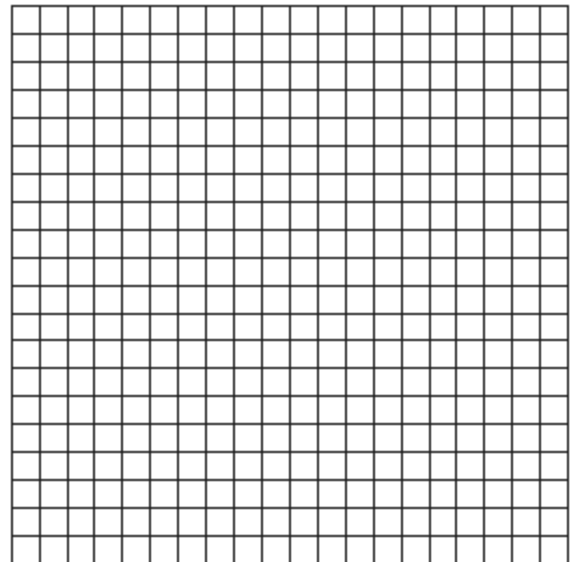

MATH TOOLBOX P. 10

STEM-AND-LEAF PLOTS

35. 010132a, P.I. A.S.5

On a science quiz, 20 students received the following scores: 100, 95, 95, 90, 85, 85, 85, 80, 80, 80, 80, 75, 75, 75, 70, 70, 65, 65, 60, 55. Construct a statistical graph, such as a histogram or a stem-and-leaf plot, to display this data. *[Be sure to title the graph and label all axes or parts used.]*

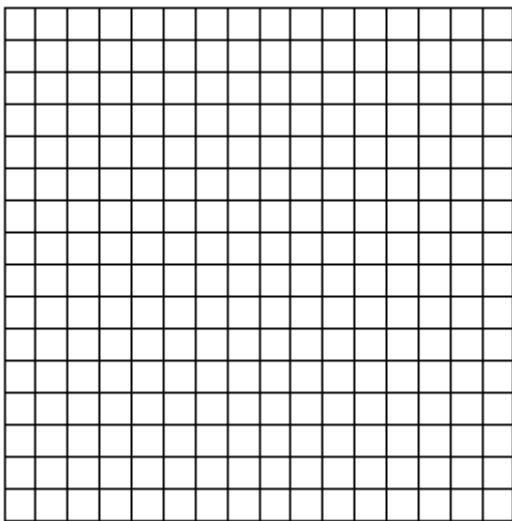

36. 010535a

Construct a stem-and-leaf plot listing the scores below in order from lowest to highest.
15, 25, 28, 32, 39, 40, 43, 26, 50, 75, 65, 19,
55, 72, 50

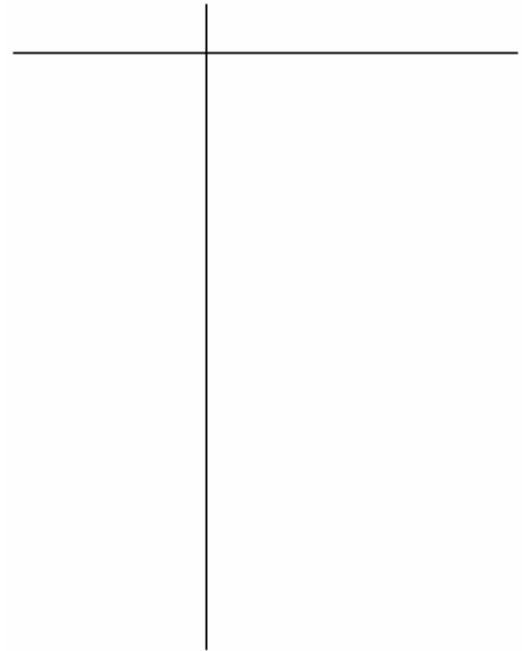

37. 060321a, P.I. 6.S.5

The student scores on Mrs. Frederick's mathematics test are shown on the stem-and-leaf plot below.

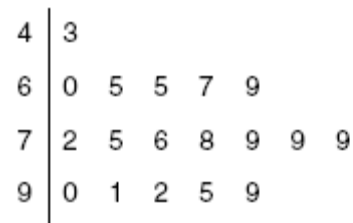

Key: 4 | 3 = 43 points

Find the median of these scores.

38. 080714a, P.I. 6.S.5

The accompanying stem-and-leaf plot represents Ben's test scores this year.

6	5	8					
7	2	3	3	3	3	3	9
8	1	3	3	6	7		
9	6	9	9				

Key: 7 | 2 = 72

What is the median score for this set of data?

- [A] 73 [B] 81 [C] 80 [D] 79

39. 060509a, P.I. 6.S.5

Jorge made the accompanying stem-and-leaf plot of the weights, in pounds, of each member of the wrestling team he was coaching.

Stem	Leaf
10	9
11	
12	3 8
13	2 4 4 6 8
14	1 3 5 5 9
15	2 3 7 7 9
16	1 3 7 8 8 8 9
17	3 8

Key: 16 | 1 = 161

What is the mode of the weights?

- [A] 150 [B] 152 [C] 145 [D] 168

CHAPTER 1-2

MODELING RELATIONSHIPS

40. 080420a, P.I. 7.A.10

Which linear equation represents the data in the accompanying table?

c	d
0	20.00
1	21.50
2	23.00
3	24.50

- [A] $d = 20.00c + 1.50$ [B] $d = 21.50c$
 [C] $d = 1.50c$ [D] $d = 1.50c + 20.00$

41. 010211a, P.I. 7.A.10

If x and y are defined as indicated by the accompanying table, which equation correctly represents the relationship between x and y ?

x	y
2	1
3	3
5	7
7	11

- [A] $y = x + 2$ [B] $y = 2x - 3$
 [C] $y = 2x + 2$ [D] $y = 2x + 3$

42. 010813a, P.I. 7.A.10

Which equation expresses the relationship between x and y , as shown in the accompanying table?

x	0	1	2	3	4
y	2	5	8	11	14

- [A] $y = x + 2$ [B] $y = 2x + 3$
 [C] $y = 3x + 2$ [D] $y = x + 3$

43. 010113a, P.I. 7.A.10
Which equation could represent the relationship between the x and y values shown in the accompanying table?

x	y
0	2
1	3
2	6
3	11
4	18

- [A] $y = x^2$ [B] $y = 2^x$
 [C] $y = x^2 + 2$ [D] $y = x + 2$
44. 060411b
Which equation models the data in the accompanying table?
- | Time in hours, x | 0 | 1 | 2 | 3 | 4 | 5 | 6 |
|--------------------|---|----|----|----|----|-----|-----|
| Population, y | 5 | 10 | 20 | 40 | 80 | 160 | 320 |
- [A] $y = 2^x$ [B] $y = 2x$
 [C] $y = 5(2^x)$ [D] $y = 2x + 5$
45. fall0729ia, P.I. A.A.2
Which verbal expression represents $2(n - 6)$?
- [A] two times six minus n
 [B] two times n minus six
 [C] two times the quantity n less than six
 [D] two times the quantity six less than n
46. 060408a, P.I. A.A.1
Tara buys two items that cost d dollars each. She gives the cashier \$20. Which expression represents the change she should receive?
- [A] $20 - d$ [B] $20 - 2d$
 [C] $2d - 20$ [D] $20 + 2d$

47. 080509a, P.I. A.A.1
The sum of Scott's age and Greg's age is 33 years. If Greg's age is represented by g , Scott's age is represented by
- [A] $33g$ [B] $33 - g$
 [C] $g - 33$ [D] $g + 33$
48. 010604a, P.I. A.A.1
Which expression represents "5 less than the product of 7 and x "?
- [A] $5 - 7x$ [B] $7 + x - 5$
 [C] $7(x - 5)$ [D] $7x - 5$
49. 010820a, P.I. A.A.1
If x represents a given number, the expression "5 less than twice the given number" is written as
- [A] $5 < 2 + x$ [B] $5 < 2x$
 [C] $5 - 2x$ [D] $2x - 5$
50. 060113b, P.I. A.A.1
A store advertises that during its Labor Day sale \$15 will be deducted from every purchase over \$100. In addition, after the deduction is taken, the store offers an early-bird discount of 20% to any person who makes a purchase before 10 a.m. If Hakeem makes a purchase of x dollars, $x > 100$, at 8 a.m., what, in terms of x , is the cost of Hakeem's purchase?
- [A] $0.80x - 12$ [B] $0.20x - 3$
 [C] $0.85x - 20$ [D] $0.20x - 15$

CHAPTER 1-3

ORDER OF OPERATIONS

51. 060314a, P.I. 7.N.11
If the expression $3 - 4^2 + \frac{6}{2}$ is evaluated,
what would be done *last*?
[A] squaring [B] dividing
[C] adding [D] subtracting
52. 080612a, P.I. 7.N.11
What is the first step in simplifying the
expression $(2 - 3 \times 4 + 5)^2$?
[A] square 5 [B] subtract 3 from 2
[C] add 4 and 5 [D] multiply 3 by 4
53. 060217a, P.I. 7.N.11
The expression $15 - 3[2 + 6(-3)]$ simplifies to
[A] -33 [B] -45 [C] 192 [D] 63
54. 010403a, P.I. 7.N.13
On February 18, from 9 a.m. until 2 p.m., the
temperature rose from -14°F to 36°F .
What was the total increase in temperature
during this time period?
[A] 50° [B] 36° [C] 32° [D] 22°

EVALUATING VARIABLE EXPRESSIONS

55. 060432a, P.I. A.CM.5
Brett was given the problem: "Evaluate
 $2x^2 + 5$ when $x = 3$." Brett wrote that the
answer was 41. Was Brett correct? Explain
your answer.
56. 080408a, P.I. 8.N.2
If $x = -4$ and $y = 3$, what is the value of
 $x - 3y^2$?
[A] -23 [B] -85 [C] -13 [D] -31

57. 010015a, P.I. 8.N.2
If $t = -3$, then $3t^2 + 5t + 6$ equals
[A] -6 [B] -36 [C] 18 [D] 6
58. 060726a, P.I. 8.N.2
If $a = 3$ and $b = -1$, what is the value of
 $ab - b^2$?
[A] -4 [B] -2 [C] 2 [D] 4
59. 010406a, P.I. 8.N.2
What is the value of $\frac{x^2 - 4y}{2}$, if $x = 4$ and
 $y = -3$?
[A] 10 [B] -2 [C] 2 [D] 14
60. 080617a, P.I. 8.N.2
If $x = 4$ and $y = -2$, the value of $\frac{1}{2}xy^2$ is
[A] 32 [B] -4 [C] -8 [D] 8

CHAPTER 1-4

PROPERTIES OF INTEGERS

61. 010824a, P.I. A.A.1
The larger of two consecutive integers is
represented by $x + 4$. Which expression
represents the *smaller* integer?
[A] $x + 5$ [B] $x + 2$
[C] $x + 6$ [D] $x + 3$
62. 010006a, P.I. A.A.1
If the number represented by $n - 3$ is an odd
integer, which expression represents the next
greater odd integer?
[A] $n - 2$ [B] $n - 1$ [C] $n - 5$ [D] $n + 1$
63. 010506a, P.I. A.A.1
If $n + 4$ represents an odd integer, the next
larger odd integer is represented by
[A] $n + 6$ [B] $n + 3$
[C] $n + 2$ [D] $n + 5$

64. 080716a, P.I. A.A.1
In the Ambrose family, the ages of the three children are three consecutive even integers. If the age of the youngest child is represented by $x + 3$, which expression represents the age of the oldest child?
- [A] $x + 6$ [B] $x + 7$
[C] $x + 8$ [D] $x + 5$

65. 010712a, P.I. A.A.1
Which expression represents the product of two consecutive odd integers, where n is an odd integer?
- [A] $n(n + 2)$ [B] $n(n + 3)$
[C] $2n + 1$ [D] $n(n + 1)$

66. 080113a, P.I. 7.N.11
If n represents an odd number, which computation results in an answer that is an even number?
- [A] $3 \times n + 1$ [B] $2 \times n - 1$
[C] $2 \times n + 1$ [D] $3 \times n - 2$

67. 060113a, P.I. 7.N.11
If a is an odd number, b an even number, and c an odd number, which expression will always be equivalent to an odd number?
- [A] $ac(b)^0$ [B] $a(bc)$
[C] $ac(b)^2$ [D] $ac(b)^1$

68. 060525a, P.I. 7.N.11
If a and b are both odd integers, which expression must always equal an odd integer?
- [A] $a - b$ [B] $a \cdot b$ [C] $a + b$ [D] $\frac{a}{b}$

69. 080326b, P.I. 7.N.11
Tom scored 23 points in a basketball game. He attempted 15 field goals and 6 free throws. If each successful field goal is 2 points and each successful free throw is 1 point, is it possible he successfully made all 6 of his free throws? Justify your answer.

70. 010107a, P.I. A.N.1
If a and b are integers, which equation is always true?
- [A] $a + b = b + a$ [B] $\frac{a}{b} = \frac{b}{a}$
[C] $a + 2b = b + 2a$ [D] $a - b = b - a$

71. 080129a, P.I. A.N.1
Ramón said that the set of integers is *not* closed for one of the basic operations (addition, subtraction, multiplication, or division). You want to show Ramón that his statement is correct. For the operation for which the set of integers is *not* closed, write an example using:
- o a positive even integer and a zero
 - o a positive and a negative even integer
 - o two negative even integers
- Be sure to explain why *each* of your examples illustrates that the set of integers is *not* closed for that operation.

72. 010217a, P.I. A.N.1
Which set is closed under division?
- [A] whole numbers [B] counting numbers
[C] integers [D] $\{1\}$

ABSOLUTE VALUE

73. 010518a, P.I. A.N.6
The expression $-|-7|$ is equivalent to
- [A] 7 [B] 1 [C] 0 [D] -7
74. 060522a, P.I. A.N.6
If $r = 2$ and $s = -7$, what is the value of $|r| - |s|$?
- [A] 5 [B] 9 [C] -9 [D] -5

CHAPTER 1-6

RATIONAL NUMBERS

75. 080208a, P.I. 7.N.17
The number 0.14114111411114 . . . is
[A] rational [B] whole
[C] integral [D] irrational
76. 010632a, P.I. 7.N.2
Write an irrational number and explain why it is irrational.
77. 069923a, P.I. 7.N.2
Which number below is irrational?
 $\sqrt{\frac{4}{9}}$, $\sqrt{20}$, $\sqrt{121}$
Why is the number you chose an irrational number?
78. 010416a, P.I. 7.N.2
Which number is irrational?
[A] $\sqrt{8}$ [B] $\sqrt{9}$ [C] $\frac{2}{3}$ [D] 0.3333
79. 060303a, P.I. 7.N.2
Which expression represents an irrational number?
[A] $\sqrt{2}$ [B] 0 [C] $\frac{1}{2}$ [D] 0.17
80. 010219a, P.I. 7.N.2
Which is an irrational number?
[A] 3.14 [B] $\sqrt{3}$ [C] $\sqrt{9}$ [D] $\frac{3}{4}$
81. 060211a, P.I. 7.N.2
Which is an irrational number?
[A] π [B] 0 [C] $-\frac{1}{3}$ [D] $\sqrt{9}$

82. 080523a, P.I. 7.N.2
Which is an irrational number?
[A] π [B] $0.\bar{3}$ [C] $\frac{3}{8}$ [D] $\sqrt{49}$
83. 080718a, P.I. 7.N.2
Which number is irrational?
[A] π [B] $\frac{5}{4}$ [C] $0.\bar{3}$ [D] $\sqrt{121}$
84. 080432a, P.I. 7.N.2
Given: $\frac{\sqrt{99}}{11}$, $\sqrt{164}$, $\sqrt{196}$
Identify the expression that is a rational number and explain why it is rational.
85. 060003a, P.I. 7.N.2
Which number is rational?
[A] $\frac{5}{4}$ [B] π [C] $\sqrt{\frac{3}{2}}$ [D] $\sqrt{7}$
86. 060120a, P.I. 7.N.2
Which is a rational number?
[A] $5\sqrt{9}$ [B] $6\sqrt{2}$ [C] $\sqrt{8}$ [D] π
87. 080102a, P.I. 7.N.2
Which expression is rational?
[A] $\sqrt{3}$ [B] π [C] $\sqrt{\frac{1}{2}}$ [D] $\sqrt{\frac{1}{4}}$

COMPARING REALS

88. 060433a, P.I. 7.N.3
Kyoko's mathematics teacher gave her the accompanying cards and asked her to arrange the cards in order from least to greatest. In what order should Kyoko arrange the cards?

π	$\sqrt{8}$	$3.\bar{1}$	$2\sqrt{3}$	$2\frac{4}{5}$
-------	------------	-------------	-------------	----------------

89. 010304a, P.I. 7.N.3
In which list are the numbers in order from least to greatest?
[A] $3.2, \pi, 3\frac{1}{3}, \sqrt{3}$ [B] $3.2, 3\frac{1}{3}, \sqrt{3}, \pi$
[C] $\sqrt{3}, 3.2, \pi, 3\frac{1}{3}$ [D] $\sqrt{3}, \pi, 3.2, 3\frac{1}{3}$
90. 080516a, P.I. 7.N.3
Which numbers are arranged from smallest to largest?
[A] $3.14, \frac{22}{7}, \pi, \sqrt{9.1}$
[B] $\sqrt{9.1}, \pi, 3.14, \frac{22}{7}$
[C] $\sqrt{9.1}, 3.14, \frac{22}{7}, \pi$
[D] $\sqrt{9.1}, 3.14, \pi, \frac{22}{7}$
91. 060609a, P.I. 7.N.3
Which list is in order from smallest value to largest value?
[A] $3.1, \pi, \frac{22}{7}, \sqrt{10}$ [B] $3.1, \frac{22}{7}, \pi, \sqrt{10}$
[C] $\sqrt{10}, \frac{22}{7}, \pi, 3.1$ [D] $\pi, \frac{22}{7}, 3.1, \sqrt{10}$
92. 010816a, P.I. 7.N.3
In which group are the numbers arranged in order from smallest value to largest value?
[A] $\sqrt{9.86}, \frac{22}{7}, 3.14, \pi$
[B] $\pi, 3.14, \sqrt{9.86}, \frac{22}{7}$
[C] $\frac{22}{7}, 3.14, \pi, \sqrt{9.86}$
[D] $3.14, \sqrt{9.86}, \pi, \frac{22}{7}$
93. 080621a, P.I. 7.N.3
Which list shows the numbers $|-0.12|, \sqrt{\frac{1}{82}}, \frac{1}{8}, \frac{1}{9}$ in order from smallest to largest?
[A] $|-0.12|, \frac{1}{8}, \frac{1}{9}, \sqrt{\frac{1}{82}}$
[B] $\frac{1}{8}, \frac{1}{9}, \sqrt{\frac{1}{82}}, |-0.12|$
[C] $\sqrt{\frac{1}{82}}, |-0.12|, \frac{1}{9}, \frac{1}{8}$
[D] $\sqrt{\frac{1}{82}}, \frac{1}{9}, |-0.12|, \frac{1}{8}$
94. 010526a, P.I. 7.N.3
Which expression has the *smallest* value?
[A] $-\frac{16}{5}$ [B] $-\pi$
[C] $-\sqrt{10}$ [D] -3.02
95. 010002a, P.I. 7.N.3
Which number has the greatest value?
[A] 1.5 [B] $\frac{\pi}{2}$ [C] $1\frac{2}{3}$ [D] $\sqrt{2}$
96. 010213a, P.I. 7.N.3
Which inequality is true if $x = \frac{3.04}{1.48}$, $y = 1.99 + 0.33$, and $z = (1.3)^3$?
[A] $y < x < z$ [B] $x < z < y$
[C] $x < y < z$ [D] $y < z < x$
97. 080717a, P.I. 7.N.3
If $t < \sqrt{t}$, t could be
[A] 2 [B] 0 [C] $\frac{1}{2}$ [D] 4

98. 069917a, P.I. 7.N.3

If $t^2 < t < \sqrt{t}$, then t could be

- [A] $\frac{1}{4}$ [B] 4 [C] $-\frac{1}{4}$ [D] 0

99. 010512a, P.I. 7.N.3

If $x^3 < x < \frac{1}{x}$, then x could be equal to

- [A] 1 [B] $\frac{6}{5}$ [C] $\frac{1}{5}$ [D] 5

100. 010120a, P.I. 7.N.3

Let x and y be numbers such that $0 < x < y < 1$, and let $d = x - y$. Which graph could represent the location of d on the number line?

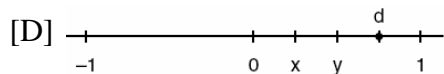
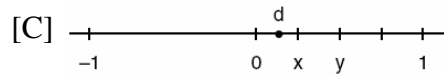
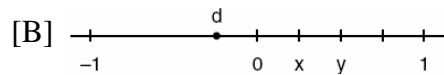
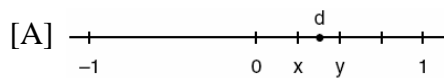

101. 080006a, P.I. 7.N.3

If $a < b$, $c < d$, and a , b , c , and d are all greater than 0, which expression is always true?

- [A] $a + c > b + d$ [B] $a - c + b - d = 0$
[C] $\frac{a}{d} > \frac{b}{c}$ [D] $ac < bd$

MATH TOOLBOX P. 35

NY LESSON 12

PROPERTIES OF REALS

102. 060424a, P.I. A.N.1

Which expression is an example of the associative property?

- [A] $x \cdot 1 = x$
[B] $(x + y) + z = x + (y + z)$
[C] $x(y + z) = xy + xz$
[D] $x + y + z = z + y + x$

103. 010428a, P.I. A.N.1

Which equation illustrates the associative property of addition?

- [A] $3(x + 2) = 3x + 6$
[B] $x + y = y + x$
[C] $(3 + x) + y = 3 + (x + y)$
[D] $3 + x = 0$

104. 080725a, P.I. A.N.1

Which equation illustrates the associative property?

- [A] $(a + b) + c = a + (b + c)$
[B] $a(b + c) = (ab) + (ac)$
[C] $a(1) = a$ [D] $a + b = b + a$

105. 060503a, P.I. A.N.1

Which equation illustrates the distributive property?

- [A] $a + (b + c) = (a + b) + c$
[B] $5(a + b) = 5a + 5b$
[C] $a + b = b + a$ [D] $a + 0 = a$

106. 060108a, P.I. A.N.1
Which equation illustrates the distributive property for real numbers?
[A] $\frac{1}{3} + \frac{1}{2} = \frac{1}{2} + \frac{1}{3}$
[B] $-3(5 + 7) = (-3)(5) + (-3)(7)$
[C] $(1.3 \times 0.07) \times 0.63 = 1.3 \times (0.07 \times 0.63)$
[D] $\sqrt{3} + 0 = \sqrt{3}$
107. 089907a, P.I. A.N.1
Which equation is an illustration of the additive identity property?
[A] $x - x = 0$ [B] $x + 0 = x$
[C] $x \cdot 1 = x$ [D] $x \cdot \frac{1}{x} = 1$
108. 060624a, P.I. A.N.1
Which statement best illustrates the additive identity property?
[A] $6 + (-6) = 0$ [B] $6(2) = 2(6)$
[C] $6 + 0 = 6$ [D] $6 + 2 = 2 + 6$
109. 010314a, P.I. A.N.1
Which equation illustrates the multiplicative identity element?
[A] $x - x = 0$ [B] $x \cdot 1 = x$
[C] $x + 0 = x$ [D] $x \cdot \frac{1}{x} = 1$
110. 010207a, P.I. A.N.1
Which expression must be added to $3x - 7$ to equal 0?
[A] $3x + 7$ [B] $-3x - 7$
[C] $-3x + 7$ [D] 0
111. 060315a, P.I. A.N.1
What is the additive inverse of $\frac{2}{3}$?
[A] $\frac{1}{3}$ [B] $\frac{3}{2}$ [C] $-\frac{2}{3}$ [D] $-\frac{3}{2}$
112. 010821a, P.I. A.N.1
The additive inverse of $\frac{1}{a}$ is
[A] $-a$ [B] $-\frac{1}{a}$ [C] a [D] 0
113. 060011a, P.I. A.N.1
If $a \neq 0$ and the sum of x and $\frac{1}{a}$ is 0, then
[A] $x = -a$ [B] $x = a$
[C] $x = -\frac{1}{a}$ [D] $x = 1 - a$
114. 010516a, P.I. A.N.1
What is the multiplicative inverse of $\frac{3}{4}$?
[A] -1 [B] $-\frac{3}{4}$ [C] $\frac{4}{3}$ [D] $-\frac{4}{3}$
115. 010730a, P.I. A.N.1
The multiplicative inverse of $-\frac{1}{3}$ is
[A] $-\frac{1}{3}$ [B] -3 [C] 3 [D] $\frac{1}{3}$
116. 010630a, P.I. A.N.1
Which equation illustrates the multiplicative inverse property?
[A] $1 \cdot 0 = 0$ [B] $1 \cdot x = x$
[C] $x \cdot \frac{1}{x} = 1$ [D] $-1 \cdot x = -x$
117. 080115a
If $a + b$ is less than $c + d$, and $d + e$ is less than $a + b$, then e is
[A] less than c [B] equal to c
[C] greater than d [D] less than d

118. 060207b

Which statement is true for all real number values of x ?

[A] $\sqrt{x^2} = x$ [B] $|x - 1| > 0$

[C] $|x - 1| > (x - 1)$ [D] $\sqrt{x^2} = |x|$

119. 060224a, P.I. A.N.1

An addition table for a subset of real numbers is shown below. Which number is the identity element? Explain your answer.

+	0	1	2	3
0	0	1	2	3
1	1	2	3	4
2	2	3	4	0
3	3	4	0	1

120. 080112a, P.I. A.N.1

The operation element @ is determined by the following table:

@	a	b	c
a	a	b	c
b	b	c	a
c	c	a	b

What is the identity element of this operation?

- [A] a and b [B] c
[C] b , only [D] a , only

121. 080514a, P.I. A.N.1

What is the identity element for \clubsuit in the accompanying table?

\clubsuit	r	s	t	u
r	t	r	u	s
s	r	s	t	u
t	u	t	s	r
u	s	u	r	t

- [A] r [B] t [C] u [D] s

122. 080222a, P.I. A.N.1

In the addition table for a subset of real numbers shown below, which number is the inverse of 3? Explain your answer.

\oplus	1	2	3	4
1	2	3	4	1
2	3	4	1	2
3	4	1	2	3
4	1	2	3	4

123. 080010a, P.I. A.N.1

The operation $*$ for the set $\{p, r, s, v\}$ is defined in the accompanying table. What is the inverse element of r under the operation $*$?

$*$	p	r	s	v
p	s	v	p	r
r	v	p	r	s
s	p	r	s	v
v	r	s	v	p

- [A] v [B] s [C] p [D] r

CHAPTER 2-1

SCATTER PLOTS

124. fall0701ia, P.I. A.S.7

For 10 days, Romero kept a record of the number of hours he spent listening to music. The information is shown in the table below.

Day	1	2	3	4	5	6	7	8	9	10
Hours	9	3	2	6	8	6	10	4	5	2

Which scatter plot shows Romero's data graphically?

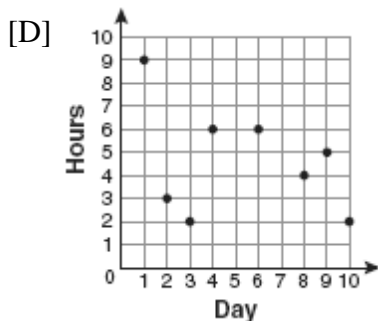
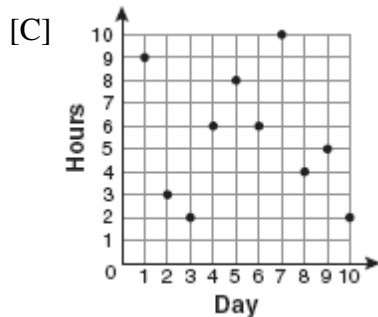
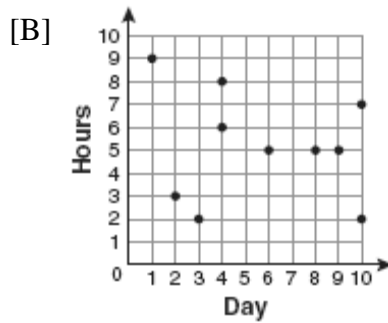
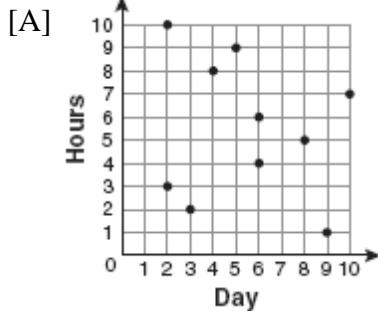

CHAPTER 2-2

RELATING GRAPHS TO EVENTS

125. 010412a, P.I. 8.A.3

John left his home and walked 3 blocks to his school, as shown in the accompanying graph.

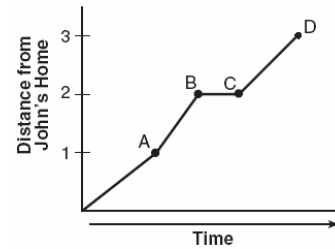

What is one possible interpretation of the section of the graph from point B to point C?

- [A] John reached the top of a hill and began walking on level ground.
- [B] John waited before crossing a busy street.
- [C] John arrived at school and stayed throughout the day.
- [D] John returned home to get his mathematics homework.

126. 080410a, P.I. 8.A.3

The accompanying graph shows the amount of water left in Rover's water dish over a period of time.

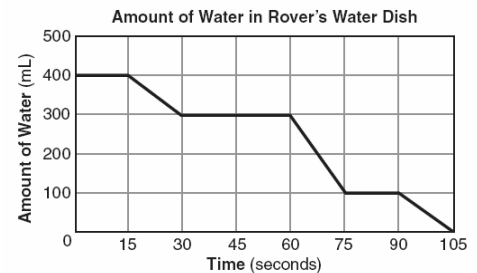

How long did Rover wait from the end of his first drink to the start of his second drink of water?

- [A] 75 sec
- [B] 60 sec
- [C] 10 sec
- [D] 30 sec

127. 010121a, P.I. 8.A.3

The accompanying graph shows Marie's distance from home (A) to work (F) at various times during her drive.

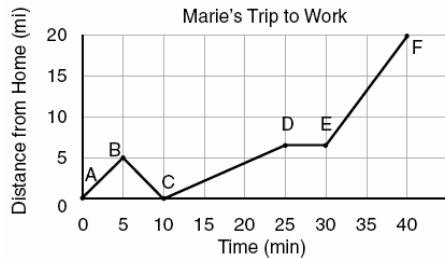

a Marie left her briefcase at home and had to return to get it. State which point represents when she turned back around to go home and explain how you arrived at that conclusion.
b Marie also had to wait at the railroad tracks for a train to pass. How long did she wait?

128. 060114b, P.I. 8.A.3

A bug travels up a tree, from the ground, over a 30-second interval. It travels fast at first and then slows down. It stops for 10 seconds, then proceeds slowly, speeding up as it goes. Which sketch best illustrates the bug's distance (d) from the ground over the 30-second interval (t)?

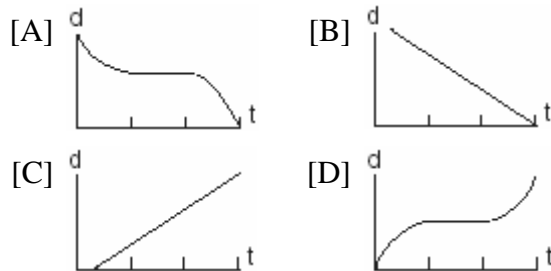

CHAPTER 2-8

THEORETICAL PROBABILITY

129. 060630a, P.I. A.S.20

Which inequality represents the probability, x , of any event happening?

- [A] $0 \leq x \leq 1$ [B] $0 < x < 1$
[C] $x < 1$ [D] $x \geq 0$

130. 010811a, P.I. A.S.20

Which event has a probability of zero?

- [A] choosing a triangle that is both isosceles and right
[B] choosing a letter from the alphabet that has line symmetry
[C] choosing a pair of parallel lines that have unequal slopes
[D] choosing a number that is greater than 6 and is even

131. 069901a, P.I. A.S.20

A fair coin is thrown in the air four times. If the coin lands with the head up on the first three tosses, what is the probability that the coin will land with the head up on the fourth toss?

- [A] $\frac{1}{2}$ [B] $\frac{1}{16}$ [C] $\frac{1}{8}$ [D] 0

132. 010209a, P.I. A.S.20

A fair coin is tossed three times. What is the probability that the coin will land tails up on the second toss?

- [A] $\frac{1}{2}$ [B] $\frac{1}{3}$ [C] $\frac{2}{3}$ [D] $\frac{3}{4}$

133. 060712a, P.I. A.S.20

When a fair coin was tossed ten times, it landed heads up the first seven times. What is the probability that on the eighth toss the coin will land with tails up?

- [A] $\frac{3}{7}$ [B] $\frac{7}{10}$ [C] $\frac{1}{2}$ [D] $\frac{3}{10}$

134. 010709a, P.I. A.S.20

Seth tossed a fair coin five times and got five heads. The probability that the next toss will be a tail is

- [A] 0 [B] $\frac{5}{6}$ [C] $\frac{1}{6}$ [D] $\frac{1}{2}$

135. 010832a, P.I. A.S.20
As captain of his football team, Jamal gets to call heads or tails for the toss of a fair coin at the beginning of each game. At the last three games, the coin has landed with heads up. What is the probability that the coin will land with heads up at the next game? Explain your answer.

136. 060415a, P.I. A.S.20
Mary chooses an integer at random from 1 to 6. What is the probability that the integer she chooses is a prime number?

- [A] $\frac{3}{6}$ [B] $\frac{2}{6}$ [C] $\frac{5}{6}$ [D] $\frac{4}{6}$

137. 080011a, P.I. A.S.20
A box contains six black balls and four white balls. What is the probability of selecting a black ball at random from the box?

- [A] $\frac{1}{10}$ [B] $\frac{6}{4}$ [C] $\frac{6}{10}$ [D] $\frac{4}{6}$

138. fall0702ia, P.I. A.S.20
Throughout history, many people have contributed to the development of mathematics. These mathematicians include Pythagoras, Euclid, Hypatia, Euler, Einstein, Agnesi, Fibonacci, and Pascal. What is the probability that a mathematician's name selected at random from those listed will start with either the letter *E* or the letter *A*?

- [A] $\frac{6}{8}$ [B] $\frac{2}{8}$ [C] $\frac{3}{8}$ [D] $\frac{4}{8}$

139. 060705a, P.I. A.S.20
A six-sided number cube has faces with the numbers 1 through 6 marked on it. What is the probability that a number less than 3 will occur on one toss of the number cube?

- [A] $\frac{1}{6}$ [B] $\frac{4}{6}$ [C] $\frac{2}{6}$ [D] $\frac{3}{6}$

140. 080604a, P.I. A.S.20
The faces of a cube are numbered from 1 to 6. What is the probability of *not* rolling a 5 on a single toss of this cube?

- [A] $\frac{1}{5}$ [B] $\frac{4}{5}$ [C] $\frac{1}{6}$ [D] $\frac{5}{6}$

141. 060202a, P.I. A.S.20
If the probability that it will rain on Thursday is $\frac{5}{6}$, what is the probability that it will *not* rain on Thursday?

- [A] 1 [B] $\frac{1}{6}$ [C] 0 [D] $\frac{5}{6}$

142. 010805a, P.I. A.S.20
A box contains 6 dimes, 8 nickels, 12 pennies, and 3 quarters. What is the probability that a coin drawn at random is *not* a dime?

- [A] $\frac{23}{29}$ [B] $\frac{12}{29}$ [C] $\frac{6}{29}$ [D] $\frac{8}{29}$

143. 010017a, P.I. A.S.20
The party registration of the voters in Jonesville is shown in the table below.

Registered Voters in Jonesville	
Party Registration	Number of Voters Registered
Democrat	6,000
Republican	5,300
Independent	3,700

If one of the registered Jonesville voters is selected at random, what is the probability that the person selected is *not* a Democrat?

- [A] 0.667 [B] 0.400
[C] 0.600 [D] 0.333

SAMPLE SPACE

144. 010321a, P.I. A.S.19
If Laquisha can enter school by any one of three doors and the school has two staircases to the second floor, in how many different ways can Laquisha reach a room on the second floor? Justify your answer by drawing a tree diagram or listing a sample space.
145. 089922a, P.I. A.S.19
The Grimaldis have three children born in different years.
a Draw a tree diagram or list a sample space to show all the possible arrangements of boy and girl children in the Grimaldi family.
b Using your information from part *a*, what is the probability that the Grimaldis have three boys?
146. 010731a, P.I. A.S.19
Kimberly has three pair of pants: one black, one red, and one tan. She also has four shirts: one pink, one white, one yellow, and one green. Draw a tree diagram or list the sample space showing all possible outfits that she could wear, if an outfit consists of one pair of pants and one shirt. How many different outfits can Kimberly wear?
147. fall0736ia, P.I. A.S.19
Mr. Laub has three children: two girls (Sue and Karen) and one boy (David). After each meal, one child is chosen at random to wash dishes. If the same child can be chosen for both lunch and dinner, construct a tree diagram or list a sample space of all the possible outcomes of who will wash dishes after lunch and dinner on Saturday. Determine the probability that one boy and one girl will wash dishes after lunch and dinner on Saturday.

CHAPTER 3-2

SOLVING TWO STEP EQUATIONS

148. 010636a, P.I. A.A.22
Solve for x : $\frac{1}{16}x + \frac{1}{4} = \frac{1}{2}$
149. 080708a, P.I. A.A.22
In the equation $\frac{1}{4}n + 5 = 5\frac{1}{2}$, n is equal to
[A] 2 [B] $\frac{1}{8}$ [C] $\frac{1}{2}$ [D] 8
150. 080219a, P.I. A.A.6
If $2x + 5 = -25$ and $-3m - 6 = 48$, what is the product of x and m ?
[A] -270 [B] 270 [C] -33 [D] 3
151. 060519a, P.I. A.A.6
If $-2x + 3 = 7$ and $3x + 1 = 5 + y$, the value of y is
[A] 10 [B] 0 [C] 1 [D] -10
152. 080213a, P.I. A.A.6
How many times larger than $\frac{1}{4}x$ is $5x$?
[A] $\frac{4}{5}$ [B] 9 [C] 20 [D] $\frac{5}{4}$
153. 010801a, P.I. A.A.6
Robin spent \$17 at an amusement park for admission and rides. If she paid \$5 for admission, and rides cost \$3 each, what is the total number of rides that she went on?
[A] 2 [B] 12 [C] 4 [D] 9

154. 060409a, P.I. A.A.6
At the beginning of her mathematics class, Mrs. Reno gives a warm-up problem. She says, "I am thinking of a number such that 6 less than the product of 7 and this number is 85." Which number is she thinking of?
- [A] 637 [B] 13 [C] 84 [D] $11\frac{2}{7}$

155. 060233a, P.I. A.N.5
Mr. Perez owns a sneaker store. He bought 350 pairs of basketball sneakers and 150 pairs of soccer sneakers from the manufacturers for \$62,500. He sold all the sneakers and made a 25% profit. If he sold the soccer sneakers for \$130 per pair, how much did he charge for one pair of basketball sneakers?

156. 010733a, P.I. A.A.6
Every month, Omar buys pizzas to serve at a party for his friends. In May, he bought three more than twice the number of pizzas he bought in April. If Omar bought 15 pizzas in May, how many pizzas did he buy in April?

CHAPTER 3-3

COMBINING LIKE TERMS

157. 080623a
The expression $2x^2 - x^2$ is equivalent to
- [A] x^2 [B] 2 [C] x^0 [D] $-2x^4$
158. 060214a, P.I. A.A.22
What is the solution of the equation $3y - 5y + 10 = 36$?
- [A] -13 [B] 13 [C] 4.5 [D] 2
159. fall0727ia, P.I. A.A.17
What is the sum of $\frac{d}{2}$ and $\frac{2d}{3}$ expressed in simplest form?
- [A] $\frac{7d}{6}$ [B] $\frac{7d}{5}$ [C] $\frac{3d}{5}$ [D] $\frac{3d}{6}$

160. 060625a, P.I. A.A.17
The expression $\frac{5x}{6} + \frac{x}{4}$ is equivalent to
- [A] $\frac{5x}{24}$ [B] $\frac{13x}{12}$ [C] $\frac{3x}{5}$ [D] $\frac{5x^2}{10}$
161. 010719a, P.I. A.A.22
What is the value of x in the equation $\frac{x}{2} + \frac{x}{6} = 2$?
- [A] 3 [B] 12 [C] $\frac{1}{4}$ [D] 8
162. 010507a, P.I. A.A.22
What is the solution set of the equation $\frac{x}{5} + \frac{x}{2} = 14$?
- [A] {49} [B] {4} [C] {20} [D] {10}
163. 069925a, P.I. A.A.6
Sara's telephone service costs \$21 per month plus \$0.25 for each local call, and long-distance calls are extra. Last month, Sara's bill was \$36.64, and it included \$6.14 in long-distance charges. How many local calls did she make?
164. 010224a, P.I. A.A.1
Ashanti and Maria went to the store to buy snacks for their back-to-school party. They bought bags of chips, pretzels, and nachos. They bought three times as many bags of pretzels as bags of chips, and two fewer bags of nachos than bags of pretzels. If x represents the number of bags of chips they bought, express, in terms of x , how many bags of snacks they bought in all.
165. 080024a, P.I. A.A.6
The sum of the ages of the three Romano brothers is 63. If their ages can be represented as consecutive integers, what is the age of the middle brother?

CHAPTER 3-4

USING THE DISTRIBUTIVE PROPERTY

166. 080413a, P.I. A.N.1
Which equation illustrates the distributive property of multiplication over addition?
- [A] $6(3a + 4b) = 6(4b + 3a)$
[B] $6(3a + 4b) = (3a + 4b)6$
[C] $6(3a + 4b) = 18a + 4b$
[D] $6(3a + 4b) = 18a + 24b$
167. 080015a, P.I. A.A.22
Solve for x : $15x - 3(3x + 4) = 6$
- [A] 1 [B] 3 [C] $-\frac{1}{2}$ [D] $\frac{1}{3}$
168. 080406a, P.I. A.A.22
What is the value of n in the equation $0.6(n + 10) = 3.6$?
- [A] 4 [B] 5 [C] -4 [D] -0.4
169. 080602a, P.I. A.A.22
What is the value of p in the equation $2(3p - 4) = 10$?
- [A] $2\frac{1}{3}$ [B] $\frac{1}{3}$ [C] 3 [D] 1
170. 060406a, P.I. A.A.6
Parking charges at Superior Parking Garage are \$5.00 for the first hour and \$1.50 for each additional 30 minutes. If Margo has \$12.50, what is the maximum amount of time she will be able to park her car at the garage?
- [A] $2\frac{1}{2}$ hours [B] $3\frac{1}{2}$ hours
[C] 6 hours [D] $6\frac{1}{2}$ hours

171. 010726a, P.I. A.A.6
Mario paid \$44.25 in taxi fare from the hotel to the airport. The cab charged \$2.25 for the first mile plus \$3.50 for each additional mile. How many miles was it from the hotel to the airport?
- [A] 11 [B] 10 [C] 13 [D] 12
172. 010635a, P.I. A.A.6
A candy store sells 8-pound bags of mixed hazelnuts and cashews. If c pounds of cashews are in a bag, the price p of the bag can be found using the formula $p = 2.59c + 1.72(8 - c)$. If one bag is priced at \$18.11, how many pounds of cashews does it contain?

CHAPTER 3-5

FRACTION MADNESS

173. 080114a, P.I. A.N.5
In his will, a man leaves one-half of his money to his wife, one-half of what is then left to his older child, and one-half of what is then left to his younger child. His two cousins divide the remainder equally, each receiving \$2,000. What was the total amount of money in the man's will?
- [A] \$40,000 [B] \$16,000
[C] \$32,000 [D] \$24,000
174. 060116a, P.I. A.N.5
A boy got 50% of the questions on a test correct. If he had 10 questions correct out of the first 12, and $\frac{1}{4}$ of the remaining questions correct, how many questions were on the test?
- [A] 24 [B] 16 [C] 26 [D] 28

MATH TOOLBOX P. 133

LOGICAL REASONING

175. 080228a, P.I. A.N.5
There are 28 students in a mathematics class.
If $\frac{1}{4}$ of the students are called to the guidance office, $\frac{1}{3}$ of the remaining students are called to the nurse, and, finally, $\frac{1}{2}$ of those left go to the library, how many students remain in the classroom?
176. 060328a, P.I. A.N.5
In a town election, candidates *A* and *B* were running for mayor. There were 30,500 people eligible to vote, and $\frac{3}{4}$ of them actually voted. Candidate *B* received $\frac{1}{3}$ of the votes cast. How many people voted for candidate *B*? What percent of the votes cast, to the nearest tenth of a percent, did candidate *A* receive?
177. 080029a, P.I. A.N.5
After an ice storm, the following headlines were reported in the *Glacier County Times*:
Monday: Ice Storm Devastates County - 8 out of every 10 homes lose electrical power
Tuesday: Restoration Begins - Power restored to $\frac{1}{2}$ of affected homes
Wednesday: More Freezing Rain - Power lost by 20% of homes that had power on Tuesday
Based on these headlines, what fractional portion of homes in Glacier County had electrical power on Wednesday?
178. 060110a
At a school costume party, seven girls wore masks and nine boys did not. If there were 15 boys at the party and 20 students did not wear masks, what was the total number of students at the party?
[A] 30 [B] 35 [C] 42 [D] 33
179. 010214a
Frank, George, and Hernando are a plumber, a cabinet maker, and an electrician, though not necessarily in that order. Each can do all work appropriate to his own field, but no work in other fields. Frank was not able to install a new electric line in his home. Hernando was not able to make cabinets. George is also a building contractor who hired one of the other people to do his electrical work. Which statement must be true?
[A] Hernando is an electrician.
[B] Frank is a plumber.
[C] Frank is an electrician.
[D] George is a cabinet maker.
180. 080026a
John, Dan, Karen, and Beth went to a costume ball. They chose to go as Anthony and Cleopatra, and Romeo and Juliet. John got the costumes for Romeo and Cleopatra, but not his own costume. Dan saw the costumes for Juliet and himself. Karen went as Anthony. Beth drove two of her friends, who were dressed as Anthony and Cleopatra, to the ball. What costume did John wear?

CHAPTER 3-6

PROBABILITY OF MULTIPLE EVENTS

181. 080430a, P.I. A.S.23
Selena and Tracey play on a softball team. Selena has 8 hits out of 20 times at bat, and Tracey has 6 hits out of 16 times at bat. Based on their past performance, what is the probability that both girls will get a hit next time at bat?
- [A] 1 [B] $\frac{31}{40}$ [C] $\frac{48}{320}$ [D] $\frac{14}{36}$
182. 060305a, P.I. A.S.23
Bob and Laquisha have volunteered to serve on the Junior Prom Committee. The names of twenty volunteers, including Bob and Laquisha, are put into a bowl. If two names are randomly drawn from the bowl without replacement, what is the probability that Bob's name will be drawn first and Laquisha's name will be drawn second?
- [A] $\frac{2}{20}$ [B] $\frac{2}{20!}$
- [C] $\frac{1}{20} \cdot \frac{1}{20}$ [D] $\frac{1}{20} \cdot \frac{1}{19}$
183. 010525a, P.I. A.S.23
A student council has seven officers, of which five are girls and two are boys. If two officers are chosen at random to attend a meeting with the principal, what is the probability that the first officer chosen is a girl and the second is a boy?
- [A] $\frac{7}{14}$ [B] $\frac{2}{7}$ [C] $\frac{10}{42}$ [D] $\frac{7}{13}$
184. 060529a, P.I. A.S.23
The probability that the Cubs win their first game is $\frac{1}{3}$. The probability that the Cubs win their second game is $\frac{3}{7}$. What is the probability that the Cubs win both games?
- [A] $\frac{1}{7}$ [B] $\frac{2}{5}$ [C] $\frac{6}{7}$ [D] $\frac{16}{21}$
185. 080127a, P.I. A.S.23
There are four students, all of different heights, who are to be randomly arranged in a line. What is the probability that the tallest student will be first in line and the shortest student will be last in line?
186. 060130a, P.I. A.S.23
Mr. Yee has 10 boys and 15 girls in his mathematics class. If he chooses two students at random to work on the blackboard, what is the probability that both students chosen are girls?

CHAPTER 3-7

PERCENTS

187. 010732a, P.I. A.N.5
A 14-gram serving of mayonnaise contains 11 grams of fat. What percent of the mayonnaise, to the *nearest tenth of a percent*, is fat?
188. 080635a, P.I. A.N.5
A recent survey shows that the average man will spend 141,288 hours sleeping, 85,725 hours working, 81,681 hours watching television, 9,945 hours commuting, 1,662 hours kissing, and 363,447 hours on other tasks during his lifetime. What percent of his life, to the *nearest tenth of a percent*, does he spend sleeping?

189. 010009a, P.I. A.N.5
Twenty-five percent of 88 is the same as what percent of 22?

[A] 100% [B] $12\frac{1}{2}\%$
[C] 40% [D] 50%

190. 060222a, P.I. A.N.5
Ninety percent of the ninth grade students at Richbartville High School take algebra. If 180 ninth grade students take algebra, how many ninth grade students do *not* take algebra?

191. 069910a, P.I. A.N.5
Linda paid \$48 for a jacket that was on sale for 25% of the original price. What was the original price of the jacket?

[A] \$72 [B] \$96 [C] \$60 [D] \$192

192. 010122a, P.I. A.N.5
Sue bought a picnic table on sale for 50% off the original price. The store charged her 10% tax and her final cost was \$22.00. What was the original price of the picnic table?

193. 089930a, P.I. A.N.5
A painting that regularly sells for a price of \$55 is on sale for 20% off. The sales tax on the painting is 7%. Will the final total cost of the painting differ depending on whether the salesperson deducts the discount before adding the sales tax or takes the discount after computing the sum of the original price and the sales tax on \$55?

194. 080436a, P.I. A.N.5
Walter is a waiter at the Towne Diner. He earns a daily wage of \$50, plus tips that are equal to 15% of the total cost of the dinners he serves. What was the total cost of the dinners he served if he earned \$170 on Tuesday?

195. 080225a, P.I. A.N.5
In bowling leagues, some players are awarded extra points called their "handicap." The "handicap" in Anthony's league is 80% of the difference between 200 and the bowler's average. Anthony's average is 145. What is Anthony's "handicap"?

196. 010626a, P.I. A.N.5
The Edison Lightbulb Company tests 5% of their daily production of lightbulbs. If 500 bulbs were tested on Tuesday, what was the total number of bulbs produced that day?

[A] 100,000 [B] 10,000
[C] 1,000 [D] 25

CHAPTER 3-8

197. 060420a, P.I. A.N.5
Rashawn bought a CD that cost \$18.99 and paid \$20.51, including sales tax. What was the rate of the sales tax?

[A] 8% [B] 5% [C] 2% [D] 3%

198. 010322a, P.I. A.N.5
The world population was 4.2 billion people in 1982. The population in 1999 reached 6 billion. Find the percent of change from 1982 to 1999.

NY LESSON 11

199. 060127a, P.I. A.N.5
A factory packs CD cases into cartons for a music company. Each carton is designed to hold 1,152 CD cases. The Quality Control Unit in the factory expects an error of less than 5% over or under the desired packing number. What is the *least* number and the *most* number of CD cases that could be packed in a carton and still be acceptable to the Quality Control Unit?

200. fall0723ia, P.I. A.M.3
The groundskeeper is replacing the turf on a football field. His measurements of the field are 130 yards by 60 yards. The actual measurements are 120 yards by 54 yards. Which expression represents the relative error in the measurement?

[A] $\frac{(120)(54)}{(130)(60) - (120)(54)}$

[B] $\frac{(130)(60) - (120)(54)}{(120)(54)}$

[C] $\frac{(130)(60) - (120)(54)}{(130)(60)}$

[D] $\frac{(130)(60)}{(130)(60) - (120)(54)}$

CHAPTER 4-1

RATIOS

201. 080002a, P.I. A.A.1
A hockey team played n games, losing four of them and winning the rest. The ratio of games won to games lost is

[A] $\frac{4}{n-4}$ [B] $\frac{n}{4}$ [C] $\frac{n-4}{4}$ [D] $\frac{4}{n}$

202. 060223a, P.I. A.A.26
If the instructions for cooking a turkey state "Roast turkey at 325° for 20 minutes per pound," how many hours will it take to roast a 20-pound turkey at 325° ?

203. 010117a, P.I. A.A.26
In a molecule of water, there are two atoms of hydrogen and one atom of oxygen. How many atoms of hydrogen are in 28 molecules of water?
- [A] 14 [B] 56 [C] 29 [D] 42

204. 060505a, P.I. A.A.26
A cake recipe calls for 1.5 cups of milk and 3 cups of flour. Seth made a mistake and used 5 cups of flour. How many cups of milk should he use to keep the proportions correct?
- [A] 2.25 [B] 2.5 [C] 1.75 [D] 2

205. 069913a, P.I. A.A.26
A total of \$450 is divided into equal shares. If Kate receives four shares, Kevin receives three shares, and Anna receives the remaining two shares, how much money did Kevin receive?
- [A] \$200 [B] \$250
[C] \$100 [D] \$150

206. 069915a, P.I. A.A.26
During a recent winter, the ratio of deer to foxes was 7 to 3 in one county of New York State. If there were 210 foxes in the county, what was the number of deer in the county?
- [A] 90 [B] 490 [C] 280 [D] 147

207. 010014a, P.I. A.A.26
Sterling silver is made of an alloy of silver and copper in the ratio of 37:3. If the mass of a sterling silver ingot is 600 grams, how much silver does it contain?
- [A] 450 g [B] 555 g
[C] 48.65 g [D] 200 g

208. 010210a, P.I. A.A.26
There are 357 seniors in Harris High School. The ratio of boys to girls is 7:10. How many boys are in the senior class?
- [A] 107 [B] 117 [C] 210 [D] 147

209. 089931a, P.I. A.A.26
The profits in a business are to be shared by the three partners in the ratio of 3 to 2 to 5. The profit for the year was \$176,500. Determine the number of dollars each partner is to receive.

210. 010331a, P.I. A.A.26
At the Phoenix Surfboard Company, \$306,000 in profits was made last year. This profit was shared by the four partners in the ratio 3:3:5:7. How much *more* money did the partner with the largest share make than one of the partners with the smallest share?

SPEED

211. 060101a, P.I. A.A.1
A car travels 110 miles in 2 hours. At the same rate of speed, how far will the car travel in h hours?

[A] $\frac{h}{55}$ [B] $220h$ [C] $\frac{h}{220}$ [D] $55h$

212. 080415a, P.I. A.A.26
A rocket car on the Bonneville Salt Flats is traveling at a rate of 640 miles per hour. How much time would it take for the car to travel 384 miles at this rate?

[A] 36 minutes [B] 256 minutes
[C] 245 minutes [D] 1.7 hours

213. 080632a, P.I. A.A.26
Running at a constant speed, Andrea covers 15 miles in $2\frac{1}{2}$ hours. At this speed, how many *minutes* will it take her to run 2 miles?

214. 010027a, P.I. A.A.6
A truck traveling at a constant rate of 45 miles per hour leaves Albany. One hour later a car traveling at a constant rate of 60 miles per hour also leaves Albany traveling in the same direction on the same highway. How long will it take for the car to catch up to the truck, if both vehicles continue in the same direction on the highway?

215. 080518a, P.I. A.A.6
A bicyclist leaves Bay Shore traveling at an average speed of 12 miles per hour. Three hours later, a car leaves Bay Shore, on the same route, traveling at an average speed of 30 miles per hour. How many hours after the car leaves Bay Shore will the car catch up to the cyclist?

[A] 4 [B] 2 [C] 5 [D] 8

216. 060010a, P.I. A.A.6
A truck travels 40 miles from point A to point B in exactly 1 hour. When the truck is halfway between point A and point B , a car starts from point A and travels at 50 miles per hour. How many miles has the car traveled when the truck reaches point B ?

[A] 60 [B] 25 [C] 40 [D] 50

217. 010125a, P.I. A.A.6
Two trains leave the same station at the same time and travel in opposite directions. One train travels at 80 kilometers per hour and the other at 100 kilometers per hour. In how many hours will they be 900 kilometers apart?

218. 010433a, P.I. A.A.6
Bob and Latoya both drove to a baseball game at a college stadium. Bob lives 70 miles from the stadium and Latoya lives 60 miles from it, as shown in the accompanying diagram. Bob drove at a rate of 50 miles per hour, and Latoya drove at a rate of 40 miles per hour. If they both left home at the same time, who got to the stadium first?

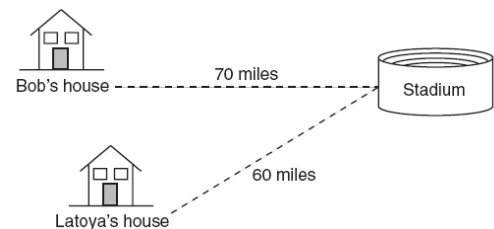

219. 080019a, P.I. A.A.6
A girl can ski down a hill five times as fast as she can climb up the same hill. If she can climb up the hill and ski down in a total of 9 minutes, how many minutes does it take her to climb up the hill?

[A] 4.5 [B] 7.2 [C] 1.8 [D] 7.5

220. 069926a, P.I. 8.G.13
During a 45-minute lunch period, Albert (A) went running and Bill (B) walked for exercise. Their times and distances are shown in the accompanying graph. How much faster was Albert running than Bill was walking, in miles per hour?

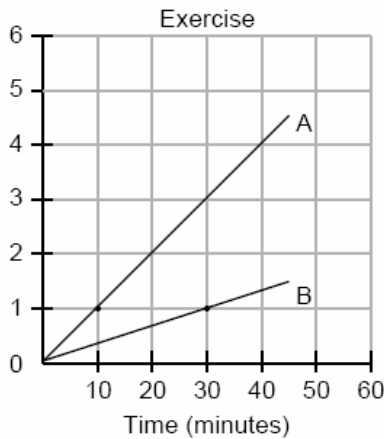

221. 080736a, P.I. A.M.1
The trip from Manhattan to Montauk Point is 120 miles by train or by car. A train makes the trip in 2 hours, while a car makes the trip in $2\frac{1}{2}$ hours. How much faster, in miles per hour, is the average speed of the train than the average speed of the car?

222. 060029a, P.I. A.N.4
The distance from Earth to the imaginary planet Med is 1.7×10^7 miles. If a spaceship is capable of traveling 1,420 miles per hour, how many days will it take the spaceship to reach the planet Med? Round your answer to the *nearest day*.

223. 060308b, P.I. A.N.4
Two objects are 2.4×10^{20} centimeters apart. A message from one object travels to the other at a rate of 1.2×10^5 centimeters per second. How many seconds does it take the message to travel from one object to the other?

[A] 2.88×10^{25} [B] 2.0×10^{15}
[C] 1.2×10^{15} [D] 2.0×10^4

224. 060116b, P.I. A.M.1
On her first trip, Sari biked 24 miles in T hours. The following week Sari biked 32 miles in T hours. Determine the ratio of her average speed on her second trip to her average speed on her first trip.

[A] $\frac{3}{2}$ [B] $\frac{4}{3}$ [C] $\frac{3}{4}$ [D] $\frac{2}{3}$

225. 080111b, P.I. A.M.1
On a trip, a student drove 40 miles per hour for 2 hours and then drove 30 miles per hour for 3 hours. What is the student's average rate of speed, in miles per hour, for the whole trip?

[A] 36 [B] 37 [C] 35 [D] 34

226. 080119b, P.I. A.M.1
If Jamar can run $\frac{3}{5}$ of a mile in 2 minutes 30 seconds, what is his rate in miles per minute?

[A] $\frac{4}{5}$ [B] $3\frac{1}{10}$ [C] $\frac{6}{25}$ [D] $4\frac{1}{6}$

227. fall0734ia, P.I. A.M.1
Hannah took a trip to visit her cousin. She drove 120 miles to reach her cousin's house and the same distance back home. It took her 1.2 hours to get halfway to her cousin's house. What was her average speed, in miles per hour, for the first 1.2 hours of the trip? Hannah's average speed for the remainder of the trip to her cousin's house was 40 miles per hour. How long, in hours, did it take her to drive the remaining distance? Traveling home along the same route, Hannah drove at an average rate of 55 miles per hour. After 2 hours her car broke down. How many miles was she from home?

SCALE

228. 080201a, P.I. A.A.26
On a map, 1 centimeter represents 40 kilometers. How many kilometers are represented by 8 centimeters?
[A] 320 [B] 280 [C] 5 [D] 48
229. 010818a, P.I. A.A.26
On a map, 1 inch represents 3 miles. How many miles long is a road that is $2\frac{1}{2}$ inches long on the map?
[A] $7\frac{1}{2}$ [B] $\frac{1}{2}$ [C] $5\frac{1}{2}$ [D] $6\frac{1}{2}$
230. 080223a, P.I. A.A.26
An image of a building in a photograph is 6 centimeters wide and 11 centimeters tall. If the image is similar to the actual building and the actual building is 174 meters wide, how tall is the actual building, in meters?

231. 080603a, P.I. A.A.26
Jordan and Missy are standing together in the schoolyard. Jordan, who is 6 feet tall, casts a shadow that is 54 inches long. At the same time, Missy casts a shadow that is 45 inches long. How tall is Missy?
[A] 86.4 in [B] 5 ft 6 in
[C] 5 ft [D] 38 in
232. 060124a, P.I. A.A.26
If a girl 1.2 meters tall casts a shadow 2 meters long, how many meters tall is a tree that casts a shadow 75 meters long at the same time?
233. 010222a, P.I. A.A.26
A 12-foot tree casts a 16-foot shadow. How many feet tall is a nearby tree that casts a 20-foot shadow at the same time?

CHAPTER 4-2

COMBINING LIKE TERMS

234. 010705a, P.I. A.A.22
What is the value of n in the equation $3n - 8 = 32 - n$?
[A] -6 [B] 10 [C] -10 [D] 6
235. 010807a, P.I. A.A.22
What is the value of p in the equation $8p + 2 = 4p - 10$?
[A] 3 [B] -1 [C] 1 [D] -3
236. fall0732ia, P.I. A.A.22
Solve for g : $3 + 2g = 5g - 9$
237. 060323a, P.I. A.A.22
Solve for m : $0.6m + 3 = 2m + 0.2$
238. 089921a, P.I. A.A.22
Solve for x : $2(x - 3) = 1.2 - x$

239. 060404a, P.I. A.A.22
If $3(x - 2) = 2x + 6$, the value of x is
[A] 20 [B] 12 [C] 0 [D] 5
240. 010401a, P.I. A.A.22
If $2(x + 3) = x + 10$, then x equals
[A] 7 [B] 5 [C] 14 [D] 4
241. 060602a, P.I. A.A.22
What is the value of x in the equation
 $13x - 2(x + 4) = 8x + 1$?
[A] 2 [B] 3 [C] 1 [D] 4
242. 060634a, P.I. A.A.22
Solve for x : $3.3 - x = 3(x - 1.7)$
243. 010601a, P.I. A.A.22
What is the value of x in the equation
 $5(2x - 7) = 15x - 10$?
[A] 1 [B] -5 [C] -9 [D] 0.6
244. 060702a, P.I. A.A.22
What is the value of x in the equation
 $6(x - 2) = 36 - 10x$?
[A] 6 [B] -6 [C] 1.5 [D] 3
245. 080731a, P.I. A.A.22
Solve for x : $5(x - 2) = 2(10 + x)$
246. 060704a, P.I. A.A.22
What is the value of w in the equation
 $\frac{1}{2}w + 7 = 2w - 2$?
[A] 6 [B] 3.6 [C] 2 [D] $3\frac{1}{3}$
247. 080620a, P.I. A.A.22
What is the value of w in the equation
 $\frac{3}{4}w + 8 = \frac{1}{3}w - 7$?
[A] -0.2 [B] -13.846 [C] 2.4 [D] -36
248. 010204a, P.I. A.A.22
What is the value of x in the equation
 $\frac{3}{4}x + 2 = \frac{5}{4}x - 6$?
[A] -16 [B] -4 [C] 4 [D] 16
249. 060310a, P.I. A.A.22
If $x + y = 9x + y$, then x is equal to
[A] 0 [B] y [C] 8 [D] $\frac{1}{5}y$
250. 010011a, P.I. A.A.22
If $9x + 2a = 3a - 4x$, then x equals
[A] $\frac{5a}{12}$ [B] $\frac{a}{13}$ [C] a [D] $-a$
251. 060513a, P.I. A.A.22
If $7x + 2a = 3x + 5a$, then x is equivalent to
[A] $\frac{3a}{10}$ [B] $\frac{7a}{4}$ [C] $\frac{7a}{10}$ [D] $\frac{3a}{4}$
252. 060111a, P.I. A.A.6
If one-half of a number is 8 less than two-thirds of the number, what is the number?
[A] 54 [B] 24 [C] 32 [D] 48
253. 060418a, P.I. A.A.6
The number of people on the school board is represented by x . Two subcommittees with an equal number of members are formed, one with $\frac{2}{3}x - 5$ members and the other with $\frac{x}{4}$ members. How many people are on the school board?
[A] 12 [B] 8 [C] 4 [D] 20

CHAPTER 4-4

TRANSFORMING FORMULAS

254. 080218a, P.I. A.A.23
If $2m + 2p = 16$, p equals
- [A] $16 - m$ [B] $8 - m$
[C] $9m$ [D] $16 + 2m$
255. 010116a, P.I. A.A.23
If $bx - 2 = K$, then x equals
- [A] $\frac{2 - K}{b}$ [B] $\frac{K}{b} + 2$
[C] $\frac{K + 2}{b}$ [D] $\frac{K - 2}{b}$
256. 060719a, P.I. A.A.23
If $c = 2m + d$, then m is equal to
- [A] $\frac{c - d}{2}$ [B] $d - 2c$
[C] $c - \frac{d}{2}$ [D] $\frac{c}{2} - d$
257. 060219a, P.I. A.A.23
If $x = 2a - b^2$, then a equals
- [A] $\frac{x - b^2}{2}$ [B] $\frac{b^2 - x}{2}$
[C] $\frac{x + b^2}{2}$ [D] $x + b^2$
258. 010421a, P.I. A.A.23
If $2ax - 5x = 2$, then x is equivalent to
- [A] $\frac{2}{2a - 5}$ [B] $7 - 2a$
[C] $\frac{2 + 5a}{2a}$ [D] $\frac{1}{a - 5}$
259. 080530a, P.I. A.A.23
If $\frac{x}{4} - \frac{a}{b} = 0$, $b \neq 0$, then x is equal to
- [A] $-\frac{a}{4b}$ [B] $-\frac{4a}{b}$ [C] $\frac{4a}{b}$ [D] $\frac{a}{4b}$
260. 080722a, P.I. A.A.23
Which equation is equivalent to $3x + 4y = 15$?
- [A] $y = 15 - 3x$ [B] $y = 3x - 15$
[C] $y = \frac{15 - 3x}{4}$ [D] $y = \frac{3x - 15}{4}$
261. 010310a, P.I. A.A.23
The equation $P = 2L + 2W$ is equivalent to
- [A] $2L = \frac{P}{2W}$ [B] $L = \frac{P - 2W}{2}$
[C] $L = \frac{P + 2W}{2}$ [D] $L = P - W$
262. 010620a, P.I. A.A.23
In the equation $A = p + prt$, t is equivalent to
- [A] $\frac{A}{pr} - p$ [B] $\frac{A}{P} - pr$
[C] $\frac{A - p}{pr}$ [D] $\frac{A - pr}{p}$
263. 060617a, P.I. A.A.23
The formula for the volume of a right circular cylinder is $V = \pi r^2 h$. The value of h can be expressed as
- [A] $\frac{V}{\pi} r^2$ [B] $V - \pi r^2$
[C] $\frac{\pi r^2}{V}$ [D] $\frac{V}{\pi r^2}$

264. 010710a, P.I. A.A.23
The formula for potential energy is $P = mgh$, where P is potential energy, m is mass, g is gravity, and h is height. Which expression can be used to represent g ?

[A] $P - m - h$ [B] $\frac{P}{mh}$
[C] $\frac{P}{m} - h$ [D] $P - mh$

265. 069922a, P.I. A.A.23
Shoe sizes and foot length are related by the formula $S = 3F - 24$, where S represents the shoe size and F represents the length of the foot, in inches.
a Solve the formula for F .
b To the *nearest tenth of an inch*, how long is the foot of a person who wears a size $10\frac{1}{2}$ shoe?

266. 010703b, P.I. A.A.23
If $\sqrt{x-a} = b, x > a$, which expression is equivalent to x ?
- [A] $b^2 + a$ [B] $b - a$
[C] $b + a$ [D] $b^2 - a$

267. 080622b, P.I. A.A.23
The volume of any spherical balloon can be found by using the formula $V = \frac{4}{3}\pi r^3$. Write an equation for r in terms of V and π .

268. 080725b, P.I. A.A.23
The slant height, ℓ , of the conical water tank shown in the accompanying diagram is

$$\ell = \sqrt[3]{\frac{8v}{\pi}}$$

Solve for v , in terms of ℓ and π .

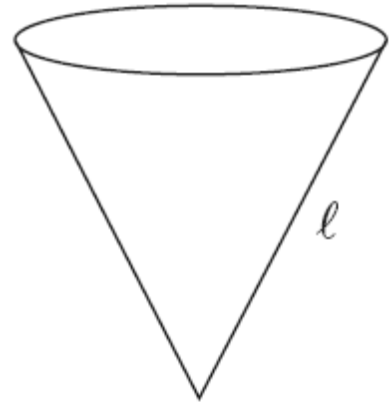

CHAPTER 4-7

SOLVING INEQUALITIES

269. 010425a, P.I. A.A.24
The inequality $\frac{1}{2}x + 3 < 2x - 6$ is equivalent to
- [A] $x < -\frac{5}{6}$ [B] $x > 6$
[C] $x > -\frac{5}{6}$ [D] $x < 6$
270. 060616a, P.I. 8.G.19
Which graph best represents the solution set for the inequality $x > \sqrt{2}$?

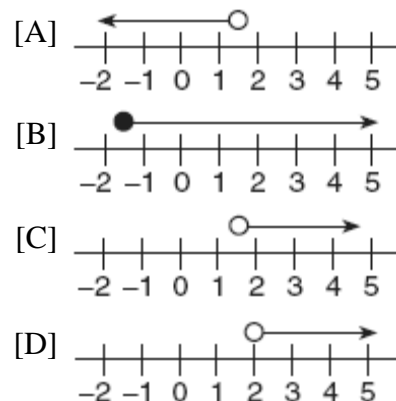

CHAPTER 4-8

271. 060001a, P.I. 8.G.19
Which inequality is represented in the graph below?



- [A] $-4 < x < 2$ [B] $-4 \leq x < 2$
[C] $-4 \leq x \leq 2$ [D] $-4 < x \leq 2$
272. 080411a, P.I. 8.G.19
Which inequality is represented in the accompanying graph?



- [A] $-3 \leq x \leq 4$ [B] $-3 < x \leq 4$
[C] $-3 \leq x < 4$ [D] $-3 < x < 4$
273. 010610a, P.I. 8.G.19
In order to be admitted for a certain ride at an amusement park, a child must be greater than or equal to 36 inches tall and less than 48 inches tall. Which graph represents these conditions?

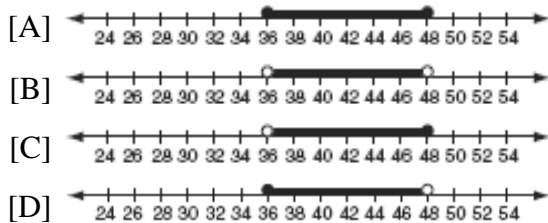

274. 010312a, P.I. 8.A.13
Which graph represents the solution set for $2x - 4 \leq 8$ and $x + 5 \geq 7$?

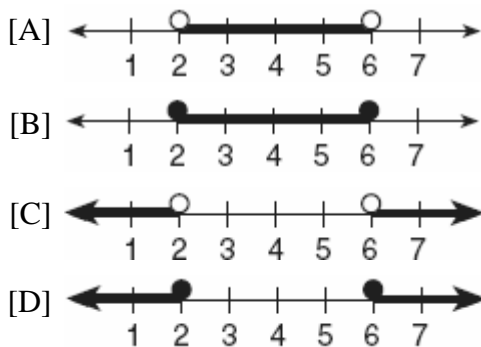

275. 060532a, P.I. 8.G.19
The manufacturer of Ron's car recommends that the tire pressure be at least 26 pounds per square inch and less than 35 pounds per square inch. On the accompanying number line, graph the inequality that represents the recommended tire pressure.



276. 089910a
On June 17, the temperature in New York City ranged from 90° to 99° , while the temperature in Niagara Falls ranged from 60° to 69° . The difference in the temperatures in these two cities must be between
- [A] 20° and 30° [B] 20° and 40°
[C] 25° and 35° [D] 30° and 40°

MATH TOOLBOX P. 201

VENN DIAGRAMS

277. 060203a, P.I. A.RP.11

The accompanying diagram shows the results of a survey asking which sports the members of the Key Club watch on television.

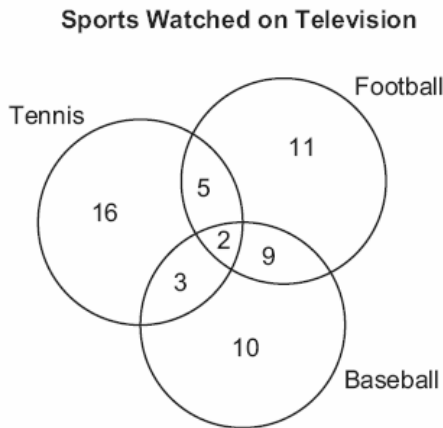

Which statement or statements are true?

- I The most watched sport is tennis.
- II The least watched sport is baseball.
- III More Key Club members watch tennis than football.

- [A] II and III, only [B] I, only
[C] I and II, only [D] II, only

278. 060026a, P.I. A.RP.11

The accompanying Venn diagram shows the number of students who take various courses. All students in circle A take mathematics. All in circle B take science. All in circle C take technology. What percentage of the students take mathematics or technology?

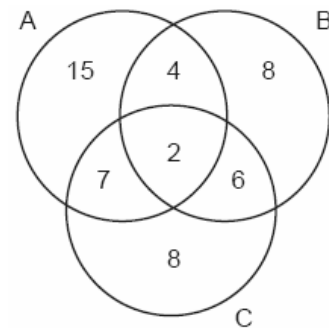

279. 010621a, P.I. A.RP.11

The accompanying Venn diagram shows the results of a survey asking 100 people if they get news by reading newspapers or by watching television.

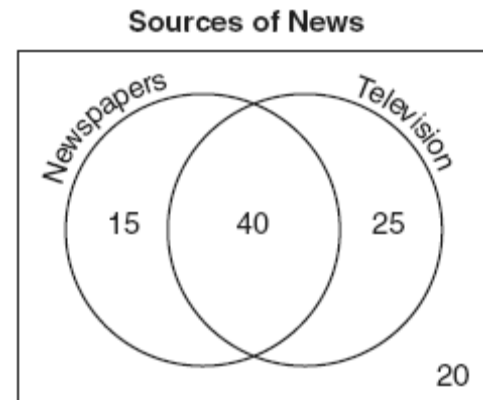

What is the probability that a person selected at random from this survey does *not* claim television as a source of getting the news?

- [A] $\frac{55}{100}$ [B] $\frac{15}{100}$ [C] $\frac{35}{100}$ [D] $\frac{75}{100}$

280. 080117a, P.I. A.RP.11
In a class of 450 students, 300 are taking a mathematics course and 260 are taking a science course. If 140 of these students are taking both courses, how many students are not taking either of these courses?
[A] 110 [B] 30 [C] 140 [D] 40
281. 069919a, P.I. A.RP.11
In a class of 50 students, 18 take music, 26 take art, and 2 take both art and music. How many students in the class are not enrolled in either music or art?
[A] 8 [B] 16 [C] 6 [D] 24
282. 060436a, P.I. A.RP.11
The senior class at South High School consists of 250 students. Of these students, 130 have brown hair, 160 have brown eyes, and 90 have both brown hair and brown eyes. How many members of the senior class have *neither* brown hair *nor* brown eyes?
283. 080226a, P.I. A.RP.11
In a telephone survey of 100 households, 32 households purchased Brand A cereal and 45 purchased Brand B cereal. If 10 households purchased both items, how many of the households surveyed did *not* purchase either Brand A or Brand B cereal?
284. 060533a, P.I. A.RP.11
In a survey of 400 teenage shoppers at a large mall, 240 said they shopped at Abernathy's, 210 said they shopped at Bongo Republic, and 90 said they shopped at both stores. How many of the teenage shoppers surveyed did not shop at either store?
285. 080631a, P.I. A.RP.11
In Clark Middle School, there are 60 students in seventh grade. If 25 of these students take art only, 18 take music only, and 9 do not take either art or music, how many take both art and music?
286. 010815a, P.I. A.RP.11
A school newspaper took a survey of 100 students. The results of the survey showed that 43 students are fans of the Buffalo Bills, 27 students are fans of the New York Jets, and 48 students do not like either team. How many of the students surveyed are fans of *both* the Buffalo Bills and the New York Jets?
[A] 52 [B] 18 [C] 16 [D] 70
287. 010434a, P.I. A.RP.11
A car dealer has 22 vehicles on his lot. If 8 of the vehicles are vans and 6 of the vehicles are red, and 10 vehicles are neither vans nor red, how many red vans does he have on his lot?
288. 060121a, P.I. A.RP.11
A school district offers hockey and basketball. The result of a survey of 300 students showed:
120 students play hockey, only
90 students play basketball, only
30 students do not participate in either sport
Of those surveyed, how many students play both hockey and basketball?
289. 080419a, P.I. A.RP.11
Seventy-eight students participate in one or more of three sports: baseball, tennis, and golf. Four students participate in all three sports; five play both baseball and golf, only; two play both tennis and golf, only; and three play both baseball and tennis, only. If seven students play only tennis and one plays only golf, what is the total number of students who play only baseball?
[A] 44 [B] 56 [C] 60 [D] 12

290. 080532a, P.I. A.RP.11
There are 30 students on a school bus. Of these students, 24 either play in the school band or sing in the chorus. Six of the students play in the school band but do not sing in the chorus. Fourteen of the students sing in the chorus and also play in the school band. How many students on the school bus sing in the chorus but do not play in the band?
291. 060732a, P.I. A.RP.11
Jose surveyed 20 of his friends to find out what equipment they use to play recorded movies. He found that 12 of his friends have only DVD players, 5 have both DVD players and VCRs, and 2 have neither type of player. The rest of his friends have only VCRs. What is the total number of his friends that have VCRs?
292. 010519a, P.I. A.RP.11
In Ms. Wright's English class, 16 students are in band, 7 students play sports, 3 students participate in both activities, and 9 students are not in band and do not play sports. How many students are in Ms. Wright's English class?
[A] 10 [B] 26 [C] 29 [D] 7
295. fall0724ia, P.I. A.A.21
Which value of x is in the solution set of the inequality $-2x + 5 > 17$?
[A] 12 [B] -4 [C] -6 [D] -8
296. 010536a, P.I. A.A.21
Find all negative odd integers that satisfy the following inequality: $-3x + 1 \leq 17$
297. 010737a, P.I. A.A.6
The Eye Surgery Institute just purchased a new laser machine for \$500,000 to use during eye surgery. The Institute must pay the inventor \$550 each time the machine is used. If the Institute charges \$2,000 for each laser surgery, what is the *minimum* number of surgeries that must be performed in order for the Institute to make a profit?
298. 080732a, P.I. A.A.6
Thelma and Laura start a lawn-mowing business and buy a lawnmower for \$225. They plan to charge \$15 to mow one lawn. What is the *minimum* number of lawns they need to mow if they wish to earn a profit of *at least* \$750?
299. fall0735ia, P.I. A.A.6
A prom ticket at Smith High School is \$120. Tom is going to save money for the ticket by walking his neighbor's dog for \$15 per week. If Tom already has saved \$22, what is the minimum number of weeks Tom must walk the dog to earn enough to pay for the prom ticket?
300. 010101a, P.I. A.A.6
There are 461 students and 20 teachers taking buses on a trip to a museum. Each bus can seat a maximum of 52. What is the *least* number of buses needed for the trip?
[A] 9 [B] 10 [C] 11 [D] 8

CHAPTER 4-9

INTERPRETING SOLUTIONS

293. 060118a, P.I. A.A.21
In the set of positive integers, what is the solution set of the inequality $2x - 3 < 5$?
[A] {1, 2, 3, 4} [B] {1, 2, 3}
[C] {0, 1, 2, 3, 4} [D] {0, 1, 2, 3}
294. 060311a, P.I. A.A.21
Which number is in the solution set of the inequality $5x + 3 > 38$?
[A] 6 [B] 8 [C] 5 [D] 7

301. 089914a, P.I. A.A.6
In a hockey league, 87 players play on seven different teams. Each team has at least 12 players. What is the largest possible number of players on any one team?

[A] 14 [B] 15 [C] 13 [D] 21

302. 080224a, P.I. A.A.6
A doughnut shop charges \$0.70 for each doughnut and \$0.30 for a carryout box. Shirley has \$5.00 to spend. At most, how many doughnuts can she buy if she also wants them in one carryout box?

303. 069928a, P.I. A.A.6
A swimmer plans to swim at least 100 laps during a 6-day period. During this period, the swimmer will increase the number of laps completed each day by one lap. What is the *least* number of laps the swimmer must complete on the first day?

306. 010115a, P.I. 8.G.13
What is the slope of line ℓ in the accompanying diagram?

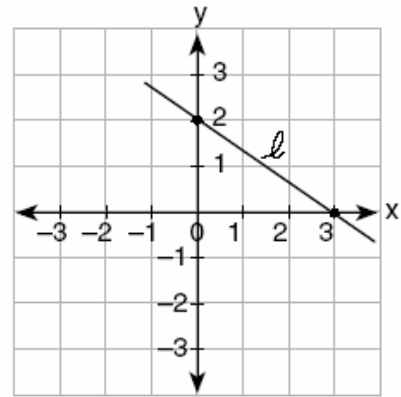

[A] $-\frac{3}{2}$ [B] $-\frac{2}{3}$ [C] $\frac{3}{2}$ [D] $\frac{2}{3}$

307. 069918a, P.I. 8.G.13
What is the slope of line ℓ shown in the accompanying diagram?

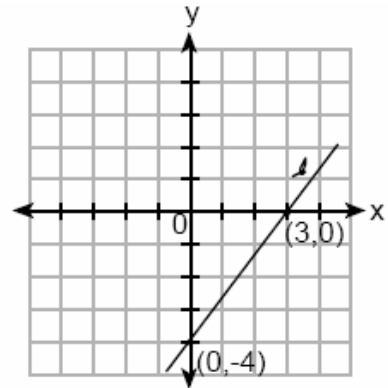

[A] $-\frac{3}{4}$ [B] $\frac{3}{4}$ [C] $-\frac{4}{3}$ [D] $\frac{4}{3}$

CHAPTER 5-1

SLOPE AND DIRECT VARIATION

304. 080417a, P.I. A.A.32
If the value of dependent variable y increases as the value of independent variable x increases, the graph of this relationship could be a

[A] line with a negative slope
[B] vertical line
[C] line with a positive slope
[D] horizontal line

305. fall0716ia, P.I. A.A.33
What is the slope of the line containing the points (3,4) and (-6,10)?

[A] $\frac{1}{2}$ [B] $-\frac{3}{2}$ [C] $-\frac{2}{3}$ [D] 2

308. 060012a, P.I. A.A.37
The accompanying figure shows the graph of the equation $x = 5$.

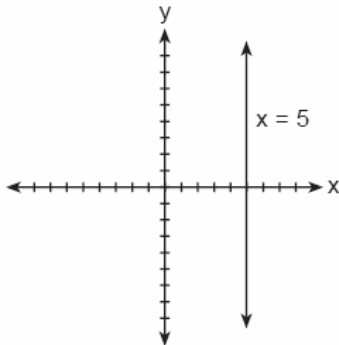

- What is the slope of the line $x = 5$?
[A] undefined [B] -5 [C] 0 [D] 5

309. 060618a
If a line is horizontal, its slope is
[A] 0 [B] 1
[C] negative [D] undefined

310. 010024a
A straight line with slope 5 contains the points (1,2) and (3,K). Find the value of K. [The use of the accompanying grid is optional.]

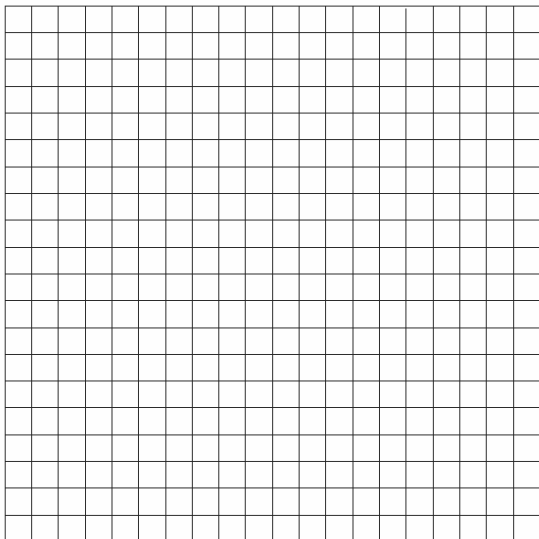

MATH TOOLBOX P. 219

CONVERSIONS

311. 010427a, P.I. A.A.1
Which expression represents the number of yards in x feet?
[A] $3x$ [B] $\frac{x}{12}$ [C] $12x$ [D] $\frac{x}{3}$
312. 060014a, P.I. A.A.1
If rain is falling at the rate of 2 inches per hour, how many inches of rain will fall in x minutes?
[A] $2x$ [B] $\frac{x}{30}$ [C] $\frac{30}{x}$ [D] $\frac{60}{x}$
313. 060709a, P.I. A.M.2
Andy is 6 feet tall. If 1 inch equals 2.54 centimeters, how tall is Andy, to the *nearest centimeter*?
[A] 213 [B] 30 [C] 15 [D] 183
314. 060731a, P.I. A.M.2
If a United States dollar is worth \$1.41 in Canadian money, how much is \$100 in Canadian money worth in United States money, to the *nearest cent*?
315. 060407a, P.I. A.M.2
If the temperature in Buffalo is 23° Fahrenheit, what is the temperature in degrees Celsius? [Use the formula $C = \frac{5}{9}(F - 32)$.]
[A] 45 [B] -45 [C] -5 [D] 5
316. 089908a, P.I. A.M.2
The formula $C = \frac{5}{9}(F - 32)$ can be used to find the Celsius temperature (C) for a given Fahrenheit temperature (F). What Celsius temperature is equal to a Fahrenheit temperature of 77° ?
[A] 8° [B] 25° [C] 171° [D] 45°

317. 060021a, P.I. A.M.2
The formula for changing Celsius (C) temperature to Fahrenheit (F) temperature is $F = \frac{9}{5}C + 32$. Calculate, to the nearest degree, the Fahrenheit temperature when the Celsius temperature is -8.

318. 010734a, P.I. A.M.2
The formula $C = \frac{5}{9}(F - 32)$ is used to convert Fahrenheit temperature, F , to Celsius temperature, C . What temperature, in degrees Fahrenheit, is equivalent to a temperature of 10° Celsius?

319. 060128a, P.I. A.M.2
Connor wants to compare Celsius and Fahrenheit temperatures by drawing a conversion graph. He knows that $-40^\circ C = -40^\circ F$ and that $20^\circ C = 68^\circ F$. On the accompanying grid, construct the conversion graph and, using the graph, determine the Celsius equivalent of $25^\circ F$.

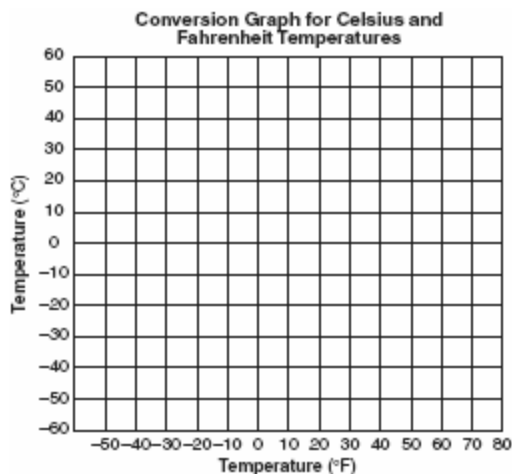

CHAPTER 5-3

SLOPE AND DIRECT VARIATION

320. 080005a
Which table does *not* show an example of direct variation?

[A]

x	y
2	24
4	12
6	8
8	6

[B]

x	y
1	4
2	8
3	12
4	16

[C]

x	y
1	$\frac{1}{2}$
2	1
3	$\frac{3}{2}$
4	2

[D]

x	y
-4	-20
-3	-15
-2	-10
-1	-5

321. 010708a, P.I. A.N.5
Which equation represents the direct variation relationship of the equation $\frac{x}{y} = \frac{1}{2}$?

[A] $y = 3x$ [B] $x = 2y$

[C] $y = x + \frac{1}{2}$ [D] $y = 2x$

322. 010806a, P.I. A.N.5
If x varies directly as y , and $x = 8$ when $y = 24$, what is the value of x when $y = 6$?

[A] 3 [B] 2 [C] 4 [D] 1

323. 010431a, P.I. A.N.5
Julio's wages vary directly as the number of hours that he works. If his wages for 5 hours are \$29.75, how much will he earn for 30 hours?

CHAPTER 5-4

SLOPE INTERCEPT FORM OF A LINE

324. 010408a, P.I. 8.G.16
An equation of the line that has a slope of 3 and a y -intercept of -2 is
- [A] $y = -2x + 3$ [B] $x = 3y - 2$
[C] $y = 3x - 2$ [D] $y = -x$
325. 010203a, P.I. A.A.37
What is the slope of the line whose equation is $2y = 5x + 4$?
- [A] 5 [B] $\frac{2}{5}$ [C] 2 [D] $\frac{5}{2}$
326. 010605a
What is the y -intercept of the graph of the line whose equation is $y = -\frac{2}{5}x + 4$?
- [A] $-\frac{5}{2}$ [B] $-\frac{2}{5}$ [C] 4 [D] 0
327. 060521a, P.I. A.A.34
If point $(-1,0)$ is on the line whose equation is $y = 2x + b$, what is the value of b ?
- [A] 2 [B] 0 [C] 1 [D] 3

CHAPTER 5-5

GRAPHING AND WRITING LINEAR EQUATIONS

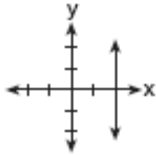
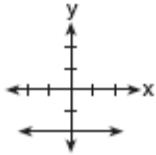
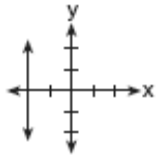
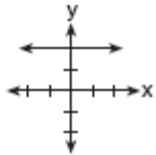
328. 060523a, P.I. A.A.36
Which graph represents the equation $x = 2$?
- [A]  [B] 
- [C]  [D] 
329. 060613a, P.I. A.A.36
Which statement describes the graph of $x = 4$?
- [A] It is parallel to the x -axis.
[B] It has a slope of 4.
[C] It passes through the point $(0, 4)$.
[D] It is parallel to the y -axis.
330. 080728a
Line segment AB has a slope of $\frac{3}{4}$. If the coordinates of point A are $(2,5)$, the coordinates of point B could be
- [A] $(-1,1)$ [B] $(5,9)$
[C] $(6,8)$ [D] $(6,2)$
331. fall0713ia, P.I. A.A.35
What is an equation for the line that passes through the coordinates $(2,0)$ and $(0,3)$?
- [A] $y = -\frac{3}{2}x - 3$ [B] $y = -\frac{2}{3}x - 2$
[C] $y = -\frac{2}{3}x + 2$ [D] $y = -\frac{3}{2}x + 3$

332. 089929a

Line ℓ contains the points $(0,4)$ and $(2,0)$.
Show that the point $(-25,81)$ does or does not
lie on line ℓ .

333. 060225a

Write the equation for the line shown in the
accompanying graph. Explain your answer.

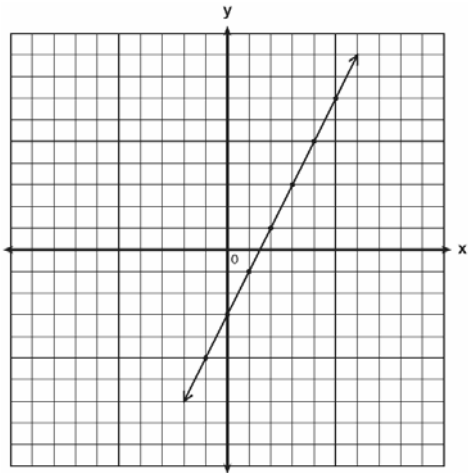

334. 080703a, P.I. A.G.4

Super Painters charges \$1.00 per square foot
plus an additional fee of \$25.00 to paint a
living room. If x represents the area of the
walls of Francesca's living room, in square
feet, and y represents the cost, in dollars,
which graph best represents the cost of
painting her living room?

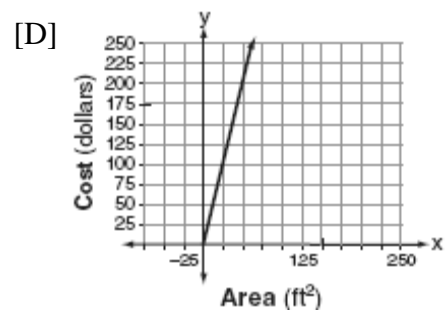
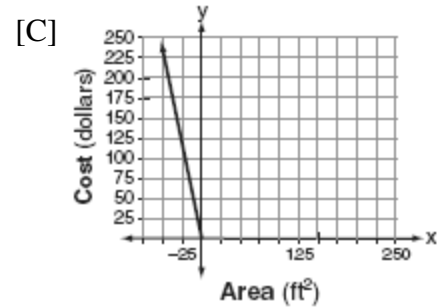
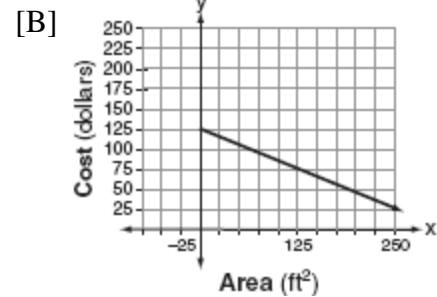
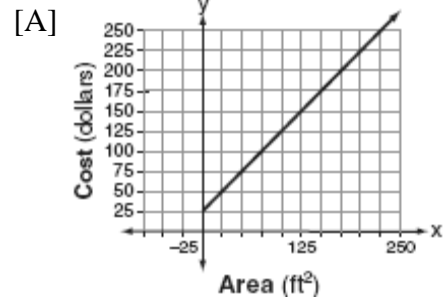

335. 060025a

The accompanying graph represents the yearly cost of playing 0 to 5 games of golf at the Shadybrook Golf Course. What is the total cost of joining the club and playing 10 games during the year?

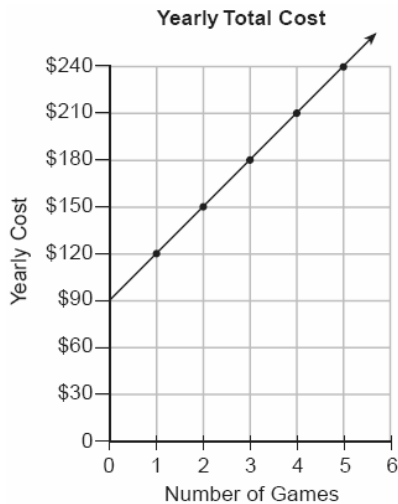

CHAPTER 5-6

REGRESSION

336. 060722b, P.I. A2.S.7

The accompanying table shows the enrollment of a preschool from 1980 through 2000. Write a linear regression equation to model the data in the table.

Year (x)	Enrollment (y)
1980	14
1985	20
1990	22
1995	28
2000	37

337. 060134b, P.I. A2.S.7

The 1999 win-loss statistics for the American League East baseball teams on a particular date is shown in the accompanying chart.

	W	L
New York	52	34
Boston	49	39
Toronto	47	43
Tampa Bay	39	49
Baltimore	36	51

Find the mean for the number of wins, \bar{W} , and the mean for the number of losses, \bar{L} , and determine if the point (\bar{W}, \bar{L}) is a point on the line of best fit. Justify your answer.

338. 010530b, P.I. A2.S.7

A real estate agent plans to compare the price of a cottage, y , in a town on the seashore to the number of blocks, x , the cottage is from the beach. The accompanying table shows a random sample of sales and location data. Write a linear regression equation that relates the price of a cottage to its distance from the beach. Use the equation to predict the price of a cottage, to the *nearest dollar*, located three blocks from the beach.

Number of Blocks from the Beach (x)	Price of a Cottage (y)
5	\$132,000
0	\$310,000
4	\$204,000
2	\$238,000
1	\$275,000
7	\$60,800

339. 080728b, P.I. A2.S.7

The accompanying table shows the percent of the adult population that married before age 25 in several different years. Using the year as the independent variable, find the linear regression equation. Round the regression coefficients to the *nearest hundredth*. Using the equation found above, estimate the percent of the adult population in the year 2009 that will marry before age 25, and round to the *nearest tenth of a percent*.

Year (x)	Percent (y)
1971	42.4
1976	37.4
1980	37.1
1984	34.1
1989	32.1
1993	28.8
1997	25.7
2000	25.5

340. 080133b, P.I. A2.S.7

The availability of leaded gasoline in New York State is decreasing, as shown in the accompanying table.

Year	1984	1988	1992	1996	2000
Gallons Available (in thousands)	150	124	104	76	50

Determine a linear relationship for x (years) versus y (gallons available), based on the data given. The data should be entered using the year and gallons available (in thousands), such as (1984,150). If this relationship continues, determine the number of gallons of leaded gasoline available in New York State in the year 2005. If this relationship continues, during what year will leaded gasoline first become unavailable in New York State?

341. 080533b, P.I. A2.S.7

The accompanying table illustrates the number of movie theaters showing a popular film and the film's weekly gross earnings, in millions of dollars.

Number of Theaters (x)	Gross Earnings (y) (millions of dollars)
443	2.57
455	2.65
493	3.73
530	4.05
569	4.76
657	4.76
723	5.15
1,064	9.35

Write the linear regression equation for this set of data, rounding values to *five decimal places*. Using this linear regression equation, find the approximate gross earnings, in millions of dollars, generated by 610 theaters. Round your answer to *two decimal places*. Find the minimum number of theaters that would generate at least 7.65 million dollars in gross earnings in one week.

342. 010328b, P.I. A2.S.7

In a mathematics class of ten students, the teacher wanted to determine how a homework grade influenced a student's performance on the subsequent test. The homework grade and subsequent test grade for each student are given in the accompanying table.

Homework Grade (x)	Test Grade (y)
94	98
95	94
92	95
87	89
82	85
80	78
75	73
65	67
50	45
20	40

a Give the equation of the linear regression line for this set of data.

b A new student comes to the class and earns a homework grade of 78. Based on the equation in part *a*, what grade would the teacher predict the student would receive on the subsequent test, to the *nearest integer*?

343. 080331b, P.I. A2.S.7

The table below shows the results of an experiment that relates the height at which a ball is dropped, x , to the height of its first bounce, y .

Drop Height (x) (cm)	Bounce Height (y) (cm)
100	26
90	23
80	21
70	18
60	16

Find \bar{x} , the mean of the drop heights. Find \bar{y} , the mean of the bounce heights. Find the linear regression equation that best fits the data. Show that (\bar{x}, \bar{y}) is a point on the line of regression. [The use of the grid is optional.]

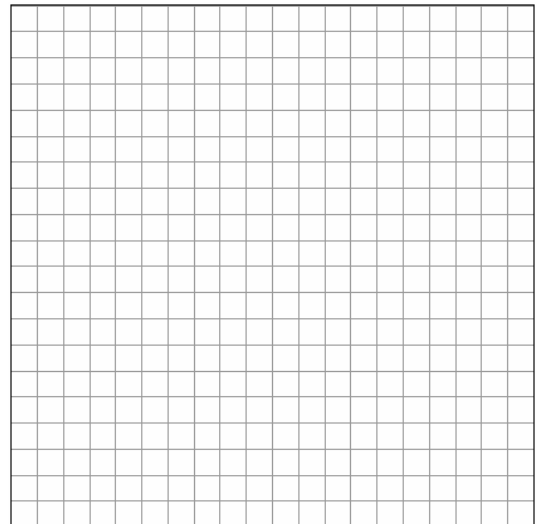

344. 010234b, P.I. A2.S.7

Two different tests were designed to measure understanding of a topic. The two tests were given to ten students with the following results:

Test x	75	78	88	92	95	67	58	72	74	81
Test y	81	73	85	88	89	73	66	75	70	78

Construct a scatter plot for these scores, and then write an equation for the line of best fit (round slope and intercept to the *nearest hundredth*).

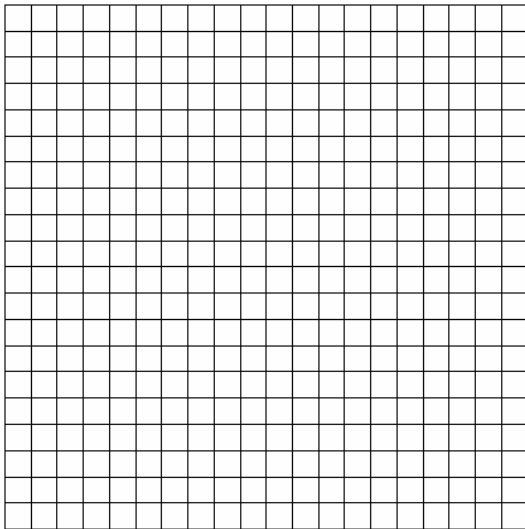

Find the correlation coefficient.
Predict the score, to the *nearest integer*, on test y for a student who scored 87 on test x .

345. 010633b, P.I. A2.S.7

Since 1990, fireworks usage nationwide has grown, as shown in the accompanying table, where t represents the number of years since 1990, and p represents the fireworks usage per year, in millions of pounds.

Number of Years Since 1990 (t)	Fireworks Usage per Year, In Millions of Pounds (p)
0	67.6
2	88.8
4	119.0
6	120.1
7	132.5
8	118.3
9	159.2
11	161.6

Find the equation of the linear regression model for this set of data, where t is the independent variable. Round values to *four decimal places*. Using this equation, determine in what year fireworks usage would have reached 99 million pounds. Based on this linear model, how many millions of pounds of fireworks would be used in the year 2008? Round your answer to the *nearest tenth*.

346. 060631b, P.I. A2.S.7
A factory is producing and stockpiling metal sheets to be shipped to an automobile manufacturing plant. The factory ships only when there is a minimum of 2,050 sheets in stock. The accompanying table shows the day, x , and the number of sheets in stock, $f(x)$.

Day (x)	Sheets in Stock ($f(x)$)
1	860
2	930
3	1000
4	1150
5	1200
6	1360

Write the linear regression equation for this set of data, rounding the coefficients to *four decimal places*. Use this equation to determine the day the sheets will be shipped.

349. 060205a, P.I. A.A.37
What is the slope of the linear equation $5y - 10x = -15$?
- [A] -15 [B] 10 [C] 2 [D] -10
350. 080619a, P.I. A.A.39
The graph of the equation $x + 3y = 6$ intersects the y -axis at the point whose coordinates are
- [A] (0,2) [B] (0,6)
[C] (6,0) [D] (0,18)
351. 080628a, P.I. A.A.39
Point $(k, -3)$ lies on the line whose equation is $x - 2y = -2$. What is the value of k ?
- [A] 8 [B] -8 [C] -6 [D] 6
352. 060721a, P.I. A.A.39
The graph of the equation $2x + 6y = 4$ passes through point $(x, -2)$. What is the value of x ?
- [A] 4 [B] 8 [C] 16 [D] -4

CHAPTER 5-7

STANDARD FORM OF A LINE

347. 060428a, P.I. A.A.37
The line $3x - 2y = 12$ has
- [A] a slope of $\frac{3}{2}$ and a y -intercept of -6
[B] a slope of 3 and a y -intercept of -2
[C] a slope of -3 and a y -intercept of -6
[D] a slope of $-\frac{3}{2}$ and a y -intercept of 6
348. 089919a, P.I. A.A.37
What is the slope of the line whose equation is $3x - 4y - 16 = 0$?
- [A] $\frac{3}{4}$ [B] $\frac{4}{3}$ [C] -4 [D] 3

CHAPTER 5-8

PARALLEL AND PERPENDICULAR LINES

353. 080009a, P.I. A.A.38
Which equation represents a line parallel to the line $y = 2x - 5$?
- [A] $y = 5x - 2$ [B] $y = 2x + 5$
[C] $y = -\frac{1}{2}x - 5$ [D] $y = -2x - 5$
354. 010522a, P.I. A.A.38
Which equation represents a line that is parallel to the line whose equation is $2x + 3y = 12$?
- [A] $6x + 4y = -2$ [B] $6y + 4x = 2$
[C] $4x - 6y = 2$ [D] $6y - 4x = 2$

355. 060528a, P.I. G.G.63
Which equation represents a line that is perpendicular to the line whose equation is $-2y = 3x + 7$?
- [A] $2y = 3x - 3$ [B] $y = \frac{2}{3}x - 3$
- [C] $y = x + 7$ [D] $y = \frac{3}{2}x - 3$
356. 080630a, P.I. G.G.63
Which line is perpendicular to the line whose equation is $5y + 6 = -3x$?
- [A] $y = \frac{3}{5}x + 7$ [B] $y = -\frac{3}{5}x + 7$
- [C] $y = -\frac{5}{3}x + 7$ [D] $y = \frac{5}{3}x + 7$
357. 010834a, P.I. G.G.64
Write an equation of a line that is perpendicular to the line $y = \frac{2}{3}x + 5$ and that passes through the point $(0,4)$.
358. 060722a, P.I. G.G.63
Which statement describes the lines whose equations are $y = \frac{1}{3}x + 12$ and $6y = 2x + 6$?
- [A] They are parallel to each other.
[B] They are perpendicular to each other.
[C] They intersect each other.
[D] They are segments.
359. 080130a, P.I. G.G.63
Shanaya graphed the line represented by the equation $y = x - 6$. Write an equation for a line that is parallel to the given line. Write an equation for a line that is perpendicular to the given line. Write an equation for a line that is identical to the given line but has different coefficients.
360. 010309a
Line P and line C lie on a coordinate plane and have equal slopes. Neither line crosses the second or third quadrant. Lines P and C must
- [A] be horizontal [B] be vertical
[C] be perpendicular
[D] form an angle of 45°
361. 060105a
Which properties best describe the coordinate graph of two distinct parallel lines?
- [A] different slopes and same intercepts
[B] same slopes and different intercepts
[C] same slopes and same intercepts
[D] different slopes and different intercepts
362. 060210a
If two lines are parallel and the slope of one of the lines is m , what is the product of their slopes?
- [A] 0 [B] $2m$ [C] 1 [D] m^2
363. 060729a
If the product of x and $\frac{1}{m}$ is -1 , $m \neq 0$, then x is equivalent to
- [A] m [B] $1 - m$ [C] $-m$ [D] $-\frac{1}{m}$

CHAPTER 6-3

SOLVING LINEAR SYSTEMS

364. 060007a, P.I. A.A.10
Which ordered pair is the solution of the following system of equations?
- $$\begin{aligned} 3x + 2y &= 4 \\ -2x + 2y &= 24 \end{aligned}$$
- [A] $(2,-1)$ [B] $(2,-5)$
[C] $(-4,8)$ [D] $(-4,-8)$

365. 080429a, P.I. A.A.10
What point is the intersection of the graphs of the lines $2x - y = 3$ and $x + y = 3$?

[A] (2, 1) [B] (1, 2)
[C] (3, 0) [D] (3, 3)

366. 060716a, P.I. A.A.10
Which ordered pair satisfies the system of equations below?

$$\begin{aligned}3x - y &= 8 \\ x + y &= 2\end{aligned}$$

[A] (2.5, 0.5) [B] (2.5, -0.5)
[C] (5, -3) [D] (3, -1)

367. 080013a, P.I. A.A.10
What is the value of y in the following system of equations?

$$\begin{aligned}2x + 3y &= 6 \\ 2x + y &= -2\end{aligned}$$

[A] 2 [B] 4 [C] 1 [D] -3

368. 080706a, P.I. A.A.10
If $a + 3b = 13$ and $a + b = 5$, the value of b is

[A] 4.5 [B] 7 [C] 1 [D] 4

369. fall0708ia, P.I. A.A.7
The equations $5x + 2y = 48$ and $3x + 2y = 32$ represent the money collected from school concert ticket sales during two class periods. If x represents the cost for each adult ticket and y represents the cost for each student ticket, what is the cost for each adult ticket?

[A] \$10 [B] \$20 [C] \$4 [D] \$8

370. 080529a, P.I. G.G.63
When solved graphically, which system of equations will have exactly one point of intersection?

[A] $y = -x - 20$ [B] $y = \frac{3}{5}x + 12$
 $y = x + 17$ $y = 0.6x - 19$

[C] $y = 0.5x + 30$ [D] $y = -x + 15$
 $y = 0.5x - 30$ $y = -x + 25$

CHAPTER 6-4

WRITING LINEAR SYSTEMS

371. 080233a, P.I. A.A.7
Tanisha and Rachel had lunch at the mall. Tanisha ordered three slices of pizza and two colas. Rachel ordered two slices of pizza and three colas. Tanisha's bill was \$6.00, and Rachel's bill was \$5.25. What was the price of one slice of pizza? What was the price of one cola?

372. 010232a, P.I. A.A.7
When Tony received his weekly allowance, he decided to purchase candy bars for all his friends. Tony bought three Milk Chocolate bars and four Creamy Nougat bars, which cost a total of \$4.25 without tax. Then he realized this candy would not be enough for all his friends, so he returned to the store and bought an additional six Milk Chocolate bars and four Creamy Nougat bars, which cost a total of \$6.50 without tax. How much did *each* type of candy bar cost?

373. 010332a, P.I. A.A.7
Alexandra purchases two doughnuts and three cookies at a doughnut shop and is charged \$3.30. Briana purchases five doughnuts and two cookies at the same shop for \$4.95. All the doughnuts have the same price and all the cookies have the same price. Find the cost of one doughnut and find the cost of one cookie.

374. 060133a, P.I. A.A.7
Ramón rented a sprayer and a generator. On his first job, he used each piece of equipment for 6 hours at a total cost of \$90. On his second job, he used the sprayer for 4 hours and the generator for 8 hours at a total cost of \$100. What was the hourly cost of *each* piece of equipment?
375. 010104a, P.I. A.A.7
Three times as many robins as cardinals visited a bird feeder. If a total of 20 robins and cardinals visited the feeder, how many were robins?
[A] 5 [B] 20 [C] 15 [D] 10
376. 080606a, P.I. A.A.7
Sal keeps quarters, nickels, and dimes in his change jar. He has a total of 52 coins. He has three more quarters than dimes and five fewer nickels than dimes. How many dimes does Sal have?
[A] 20 [B] 18 [C] 21 [D] 13
377. 089916a, P.I. A.A.7
At a concert, \$720 was collected for hot dogs, hamburgers, and soft drinks. All three items sold for \$1.00 each. Twice as many hot dogs were sold as hamburgers. Three times as many soft drinks were sold as hamburgers. The number of soft drinks sold was
[A] 480 [B] 120 [C] 360 [D] 240
378. 060326a, P.I. A.A.7
Seth has one less than twice the number of compact discs (CDs) that Jason has. Raoul has 53 more CDs than Jason has. If Seth gives Jason 25 CDs, Seth and Jason will have the same number of CDs. How many CDs did *each* of the three boys have to begin with?
379. 010033a, P.I. A.A.7
A group of 148 people is spending five days at a summer camp. The cook ordered 12 pounds of food for each adult and 9 pounds of food for each child. A total of 1,410 pounds of food was ordered.
a Write an equation or a system of equations that describes the above situation and define your variables.
b Using your work from part *a*, find:
(1) the total number of adults in the group
(2) the total number of children in the group
380. 010327a, P.I. A.A.7
Arielle has a collection of grasshoppers and crickets. She has 561 insects in all. The number of grasshoppers is twice the number of crickets. Find the number of *each* type of insect that she has.
381. 010022a, P.I. A.A.7
Mary and Amy had a total of 20 yards of material from which to make costumes. Mary used three times more material to make her costume than Amy used, and 2 yards of material was not used. How many yards of materials did Amy use for her costume?
382. 060123a, P.I. A.A.7
Ben had twice as many nickels as dimes. Altogether, Ben had \$4.20. How many nickels *and* how many dimes did Ben have?
383. 010436a, P.I. A.A.7
Using only 32-cent and 20-cent stamps, Charlie put \$3.36 postage on a package he sent to his sister. He used twice as many 32-cent stamps as 20-cent stamps. Determine how many of *each* type of stamp he used.

384. 060031a, P.I. A.A.7
The owner of a movie theater was counting the money from 1 day's ticket sales. He knew that a total of 150 tickets were sold. Adult tickets cost \$7.50 each and children's tickets cost \$4.75 each. If the total receipts for the day were \$891.25, how many of *each* kind of ticket were sold?
385. 010134a, P.I. A.A.7
There were 100 more balcony tickets than main-floor tickets sold for a concert. The balcony tickets sold for \$4 and the main-floor tickets sold for \$12. The total amount of sales for both types of tickets was \$3,056.
a Write an equation or a system of equations that describes the given situation. Define the variables.
b Find the number of balcony tickets that were sold.
386. 080132a, P.I. A.A.7
The ninth graders at a high school are raising money by selling T-shirts and baseball caps. The number of T-shirts sold was three times the number of caps. The profit they received for each T-shirt sold was \$5.00, and the profit on each cap was \$2.50. If the students made a total profit of \$210, how many T-shirts *and* how many caps were sold?
387. 010539a, P.I. A.A.7
The tickets for a dance recital cost \$5.00 for adults and \$2.00 for children. If the total number of tickets sold was 295 and the total amount collected was \$1,220, how many adult tickets were sold? [Only an algebraic solution can receive full credit.]
388. 060531a, P.I. A.A.7
A ribbon 56 centimeters long is cut into two pieces. One of the pieces is three times longer than the other. Find the lengths, in centimeters, of both pieces of ribbon.
389. 060638a, P.I. A.A.7
Sharu has \$2.35 in nickels and dimes. If he has a total of thirty-two coins, how many of *each* coin does he have?
390. 080412a, P.I. A.A.7
The ratio of Tariq's telephone bill to Pria's telephone bill was 7:5. Tariq's bill was \$14 more than Pria's bill. What was Tariq's bill?
[A] \$21 [B] \$49 [C] \$35 [D] \$28
391. 060004a, P.I. A.A.7
Two numbers are in the ratio 2:5. If 6 is subtracted from their sum, the result is 50. What is the larger number?
[A] 35 [B] 55 [C] 45 [D] 40
392. 060201a, P.I. A.A.7
Jamie is 5 years older than her sister Amy. If the sum of their ages is 19, how old is Jamie?
[A] 12 [B] 7 [C] 14 [D] 5
393. 010228a, P.I. A.A.7
A total of 600 tickets were sold for a concert. Twice as many tickets were sold in advance than were sold at the door. If the tickets sold in advance cost \$25 each and the tickets sold at the door cost \$32 each, how much money was collected for the concert?
394. 010228b, P.I. A.A.7
At the local video rental store, José rents two movies and three games for a total of \$15.50. At the same time, Meg rents three movies and one game for a total of \$12.05. How much money is needed to rent a combination of one game and one movie?
395. 060123b, P.I. A.A.7
The cost of a long-distance telephone call is determined by a flat fee for the first 5 minutes and a fixed amount for each additional minute. If a 15-minute telephone call costs \$3.25 and a 23-minute call costs \$5.17, find the cost of a 30-minute call.

BREAK EVEN

396. 089935a, P.I. A.A.7
Two health clubs offer different membership plans. The graph below represents the total cost of belonging to Club A and Club B for one year.

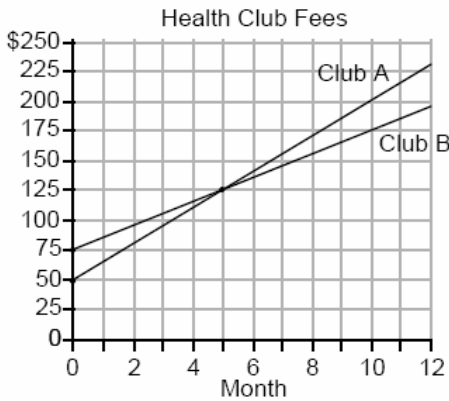

- a If the yearly cost includes a membership fee plus a monthly charge, what is the membership fee for Club A?
b (1) What is the number of the month when the total cost is the same for both clubs?
(2) What is the total cost for Club A when both plans are the same?
c What is the monthly charge for Club B?

397. 060232a, P.I. A.A.7
At Ron's Rental, a person can rent a big-screen television for \$10 a month plus a one-time "wear-and-tear" fee of \$100. At Josie's Rental, the charge is \$20 a month and an additional charge of \$20 for delivery with no "wear-and-tear" fee.
a If c equals the cost, write one equation representing the cost of the rental for m months at Ron's Rental and one equation representing the cost of the rental for m months at Josie's Rental.
b On the accompanying grid, graph and label each equation.
c From your graph, determine in which month Josie's cost will equal Ron's cost.

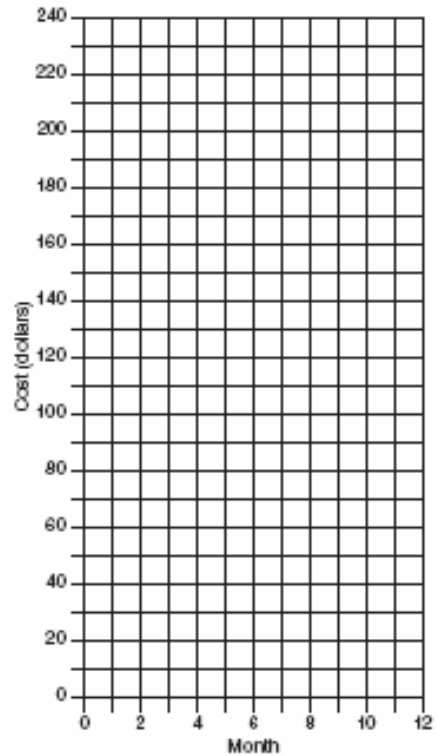

398. 060335a, P.I. A.A.7

The senior class is sponsoring a dance. The cost of a student disk jockey is \$40, and tickets sell for \$2 each. Write a linear equation and, on the accompanying grid, graph the equation to represent the relationship between the number of tickets sold and the profit from the dance. Then find how many tickets must be sold to break even.

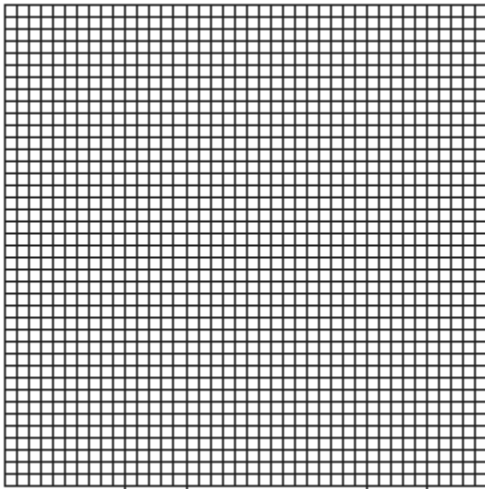

399. 010329a, P.I. A.A.7

Currently, Tyrone has \$60 and his sister has \$135. Both get an allowance of \$5 each week. Tyrone decides to save his entire allowance, but his sister spends all of hers each week plus an additional \$10 each week. After how many weeks will they each have the same amount of money? [The use of the grid is optional.]

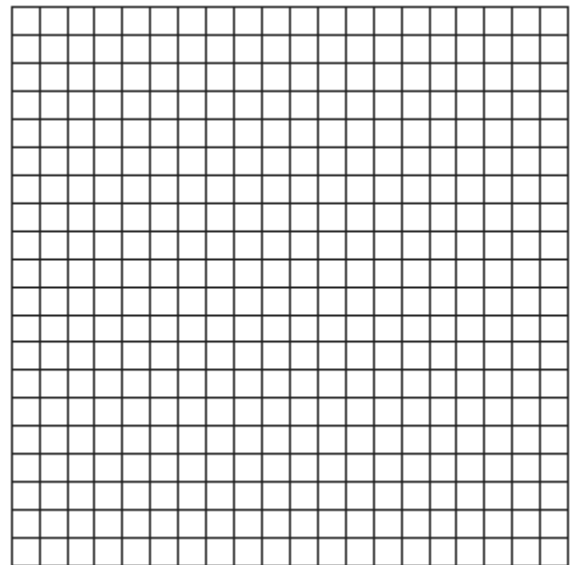

400. 010130a, P.I. A.A.7

Juan has a cellular phone that costs \$12.95 per month plus 25¢ per minute for each call. Tiffany has a cellular phone that costs \$14.95 per month plus 15¢ per minute for each call. For what number of minutes do the two plans cost the same?

401. 060117a, P.I. A.A.7

A hotel charges \$20 for the use of its dining room and \$2.50 a plate for each dinner. An association gives a dinner and charges \$3 a plate but invites four nonpaying guests. If each person has one plate, how many paying persons must attend for the association to collect the exact amount needed to pay the hotel?

- [A] 60 [B] 20 [C] 44 [D] 40

402. 010035a, P.I. A.A.7
The Excel Cable Company has a monthly fee of \$32.00 and an additional charge of \$8.00 for each premium channel. The Best Cable Company has a monthly fee of \$26.00 and additional charge of \$10.00 for each premium channel. The Horton family is deciding which of these two cable companies to subscribe to.
- a* For what number of premium channels will the total monthly subscription fee for the Excel and Best Cable companies be the same?
- b* The Horton family decides to subscribe to 2 premium channels for a period of one year.
- (1) Which cable company should they subscribe to in order to spend less money?
- (2) How much money will the Hortons save in one year by using the less expensive company?

403. 080114b, P.I. A.A.7
A cellular telephone company has two plans. Plan A charges \$11 a month and \$0.21 per minute. Plan B charges \$20 a month and \$0.10 per minute. After how much time, to the *nearest minute*, will the cost of plan A be equal to the cost of plan B?

- [A] 81 hr 8 min [B] 81 hr 48 min
[C] 1 hr 36 min [D] 1 hr 22 m

404. 060226b, P.I. A.A.7
Island Rent-a-Car charges a car rental fee of \$40 plus \$5 per hour or fraction of an hour. Wayne's Wheels charges a car rental fee of \$25 plus \$7.50 per hour or fraction of an hour. Under what conditions does it cost *less* to rent from Island Rent-a-Car? [The use of the accompanying grid is optional.]

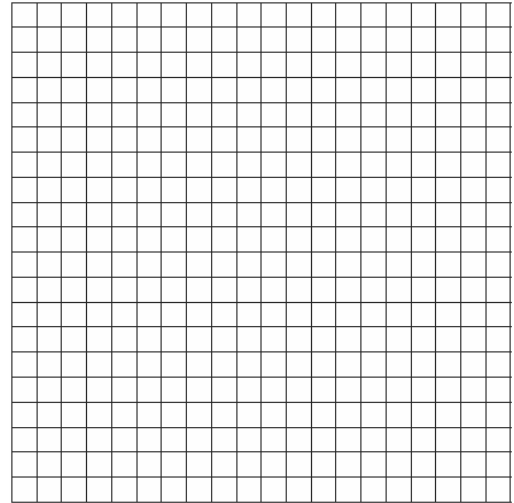

CHAPTER 6-5

LINEAR INEQUALITIES

405. fall0715ia, P.I. A.A.4
An electronics store sells DVD players and cordless telephones. The store makes a \$75 profit on the sale of each DVD player (*d*) and a \$30 profit on the sale of each cordless telephone (*c*). The store wants to make a profit of at least \$255.00 from its sales of DVD players and cordless phones. Which inequality describes this situation?
- [A] $75d + 30c \leq 255$ [B] $75d + 30c > 255$
[C] $75d + 30c \geq 255$ [D] $75d + 30c < 255$
406. 080513a, P.I. A.A.21
Which ordered pair is not in the solution set of $y > 2x + 1$?
- [A] (1,6) [B] (3,8) [C] (1,4) [D] (2,5)

407. 080220a

In the graph of $y \leq -x$, which quadrant is completely shaded?

- [A] IV [B] I [C] II [D] III

408. 010629a, P.I. A.G.6

Which inequality is represented by the accompanying graph?

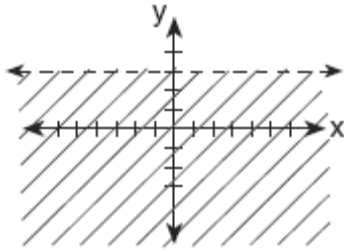

- [A] $y \geq 3$ [B] $y < 3$
[C] $y > 3$ [D] $y \leq 3$

409. fall0720ia, P.I. A.G.6

Which inequality is represented by the graph below?

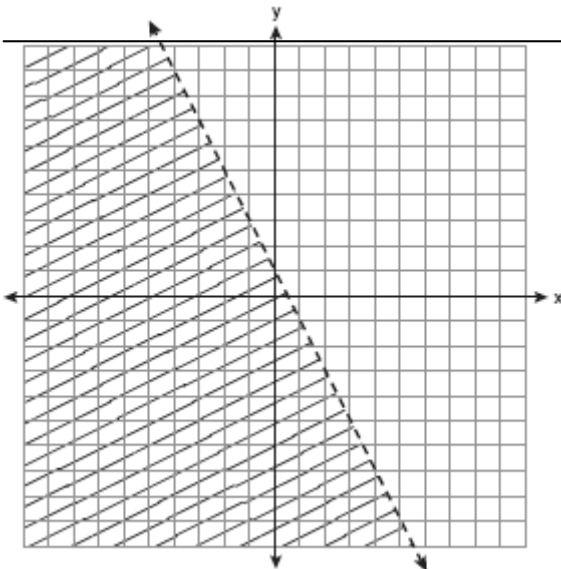

- [A] $y < 2x + 1$ [B] $y < -\frac{1}{2}x + 1$
[C] $y < -2x + 1$ [D] $y < \frac{1}{2}x + 1$

410. 010828a, P.I. A.G.6

Which inequality is shown in the accompanying diagram?

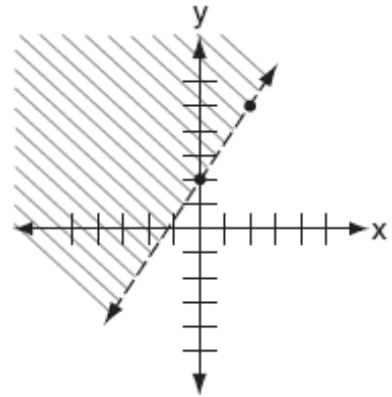

- [A] $y \geq \frac{3}{2}x + 2$ [B] $y < \frac{3}{2}x + 2$
[C] $y > \frac{3}{2}x + 2$ [D] $y \leq \frac{3}{2}x + 2$

CHAPTER 6-6

SYSTEMS OF LINEAR INEQUALITIES

411. 080615a, P.I. A.A.40

Which ordered pair is in the solution set of the system of inequalities shown in the accompanying graph?

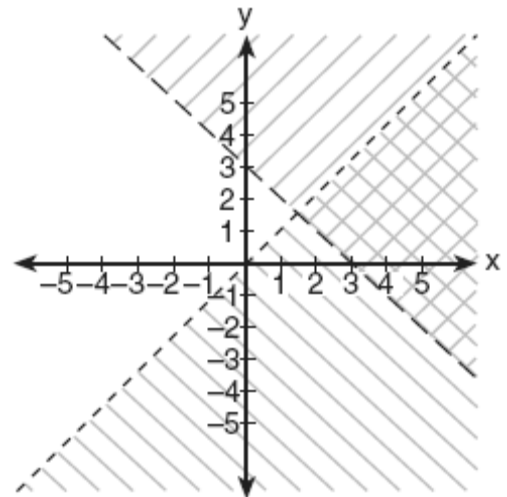

- [A] (0,0) [B] (3,2) [C] (1,5) [D] (0,1)

412. 010528a, P.I. A.A.40

Which point is in the solution set of the system of inequalities shown in the accompanying graph?

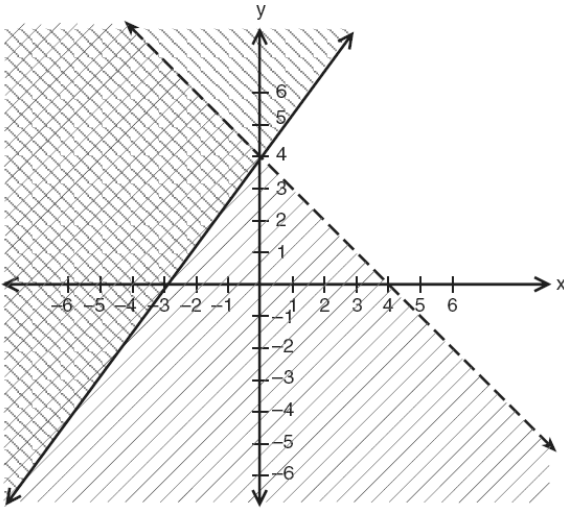

- [A] (-4, 1) [B] (4, -1)
[C] (0, 4) [D] (2, 4)

413. 060620a, P.I. A.A.40

Which coordinate point is in the solution set for the system of inequalities shown in the accompanying graph?

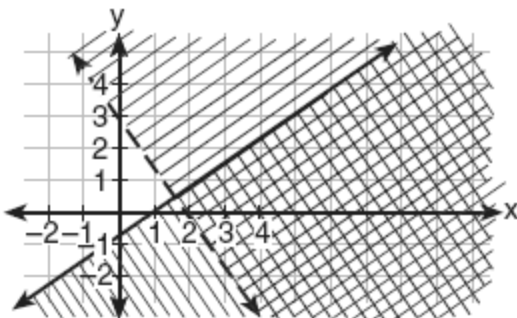

- [A] (0,1) [B] (2,2)
[C] (1,-1) [D] (3,1)

414. 010738a, P.I. A.G.7

Graph the following systems of inequalities on the accompanying set of axes and label the solution set S :

$$y > x - 4$$

$$y + x \geq 2$$

[Only a graphic solution can receive full credit.]

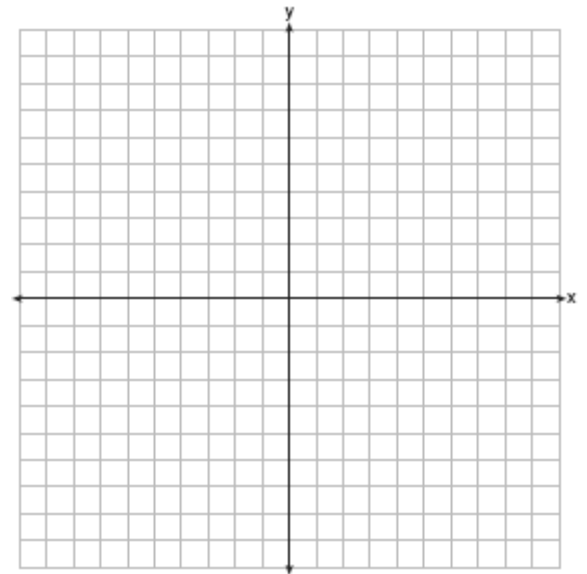

CHAPTER 6-7

LINEAR PROGRAMMING

415. 010234a, P.I. A.G.7
A company manufactures bicycles and skateboards. The company's daily production of bicycles cannot exceed 10, and its daily production of skateboards must be less than or equal to 12. The combined number of bicycles and skateboards cannot be more than 16. If x is the number of bicycles and y is the number of skateboards, graph on the accompanying set of axes the region that contains the number of bicycles and skateboards the company can manufacture daily.

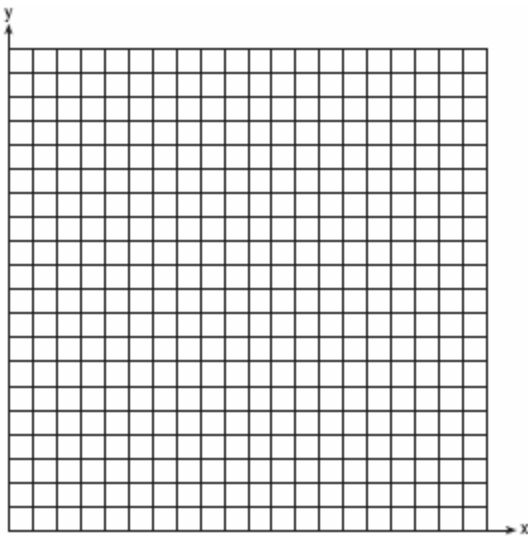

CHAPTER 6-8

SOLVING NONLINEAR SYSTEMS

416. 060507a
The accompanying diagram shows the graphs of a linear equation and a quadratic equation.

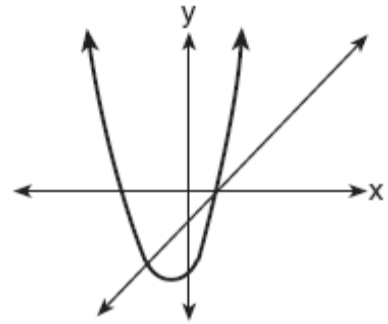

How many solutions are there to this system of equations?

- [A] 0 [B] 3 [C] 2 [D] 1

417. 060018a, P.I. A.A.11
The graphs of the equations $y = x^2 + 4x - 1$ and $y + 3 = x$ are drawn on the same set of axes. At which point do the graphs intersect?
- [A] (1, 4) [B] (-2, 1)
[C] (1, -2) [D] (-2, -5)
418. 080135a, P.I. A.A.11
Solve the following system of equations algebraically:

$$y = x^2 + 4x - 2$$

$$y = 2x + 1$$

419. 080538a, P.I. A.A.11

Solve the following system of equations:

$$y = x^2 + 4x + 1$$

$$y = 5x + 3$$

[The use of the grid is optional.]

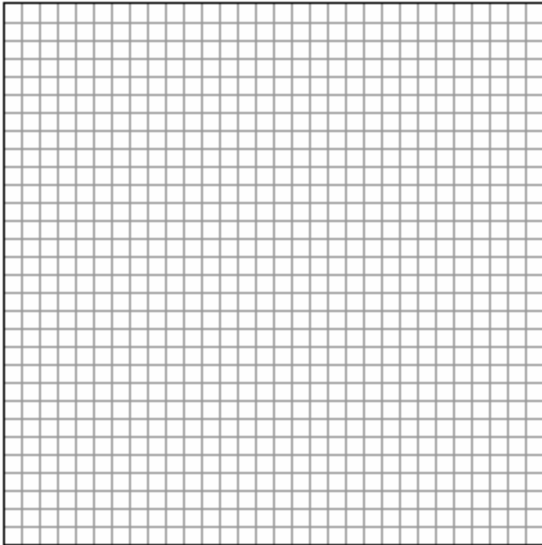

420. 069935a, P.I. A.A.11

Solve the following system of equations algebraically or graphically for x and y :

$$y = x^2 + 2x - 1$$

$$y = 3x + 5$$

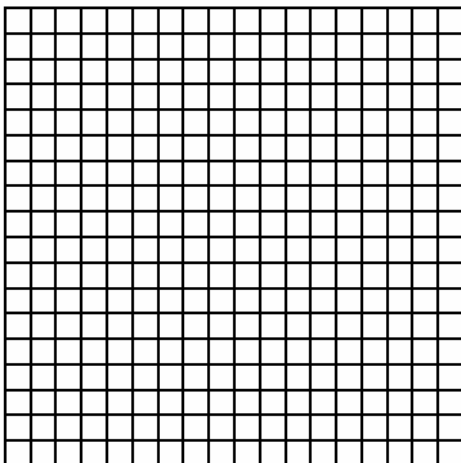

421. fall0738ia, P.I. A.G.9

Solve the following systems of equations graphically, on the set of axes below, and state the coordinate(s) of the point(s) in the solution set.

$$y = x^2 - 6x + 5$$

$$2x + y = 5$$

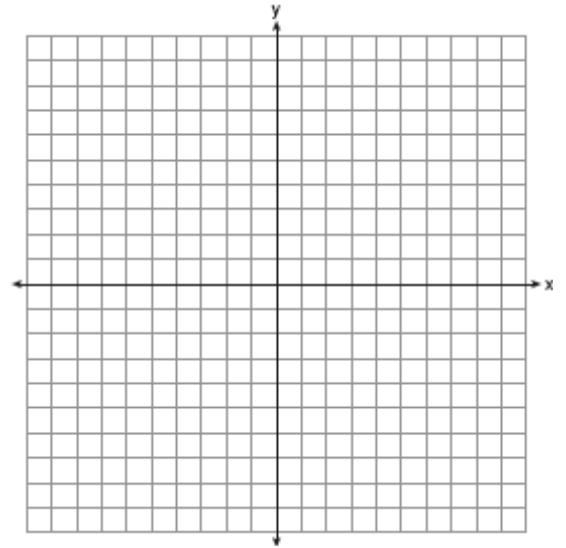

422. 060235a, P.I. A.G.9

A rocket is launched from the ground and follows a parabolic path represented by the equation $y = -x^2 + 10x$. At the same time, a flare is launched from a height of 10 feet and follows a straight path represented by the equation $y = -x + 10$. Using the accompanying set of axes, graph the equations that represent the paths of the rocket and the flare, and find the coordinates of the point or points where the paths intersect.

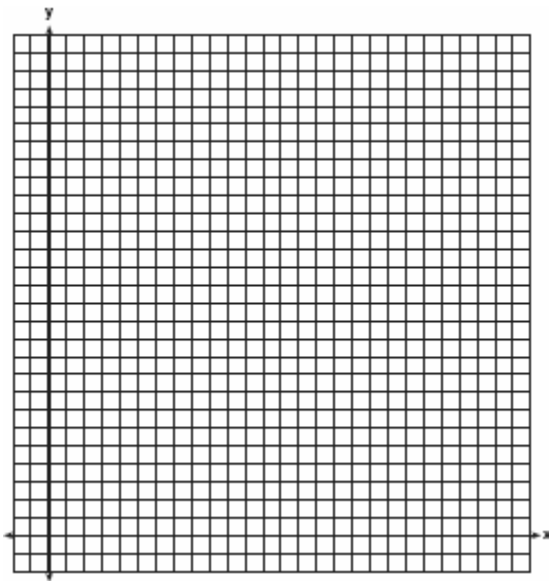

423. 060228b, P.I. A.A.11

A pelican flying in the air over water drops a crab from a height of 30 feet. The distance the crab is from the water as it falls can be represented by the function $h(t) = -16t^2 + 30$, where t is time, in seconds. To catch the crab as it falls, a gull flies along a path represented by the function $g(t) = -8t + 15$. Can the gull catch the crab before the crab hits the water? Justify your answer. [The use of the accompanying grid is optional.]

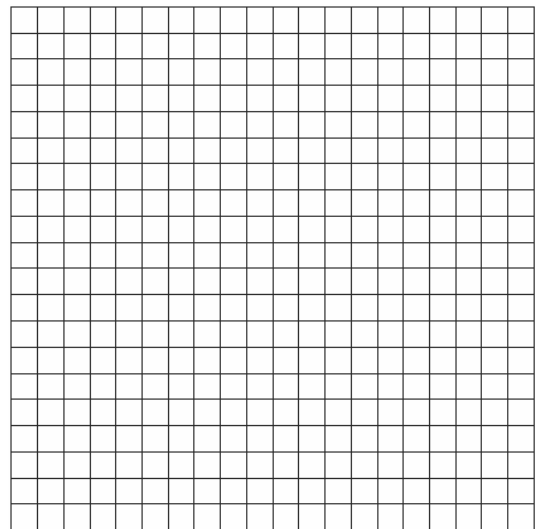

424. 060328b, P.I. G.G.70

The price of a stock, $A(x)$, over a 12-month period decreased and then increased according to the equation

$A(x) = 0.75x^2 - 6x + 20$, where x equals the number of months. The price of another stock, $B(x)$, increased according to the equation $B(x) = 2.75x + 150$ over the same 12-month period. Graph and label both equations on the accompanying grid. State all prices, to the *nearest dollar*, when both stock values were the same.

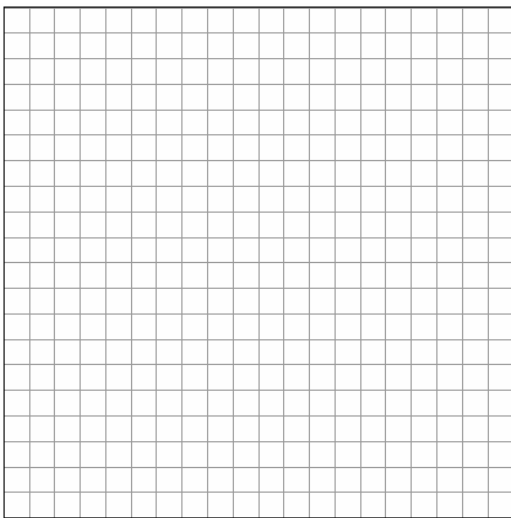

425. 080611b

What is the total number of points of intersection for the graphs of the equations $y = x^2$ and $y = -x^2$?

- [A] 2 [B] 3 [C] 1 [D] 0

426. 060706b

What is one solution of the accompanying system of equations?

$$y = -x^2 + 5$$

$$y = -0.5x^2 + 3$$

- [A] (-2,1) [B] (0,3)
[C] (0,5) [D] (3,5)

CHAPTER 7-1

QUADRATIC FUNCTIONS

427. 060404b, P.I. A.G.4

Which quadratic function is shown in the accompanying graph?

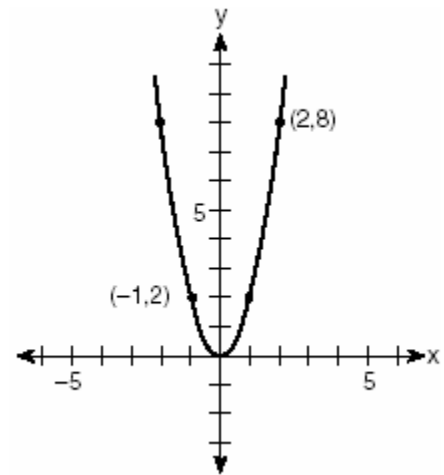

- [A] $y = 2x^2$ [B] $y = -\frac{1}{2}x^2$
[C] $y = -2x^2$ [D] $y = \frac{1}{2}x^2$

CHAPTER 7-2

428. 010801b, P.I. A.G.4
Which equation is represented by the accompanying graph?

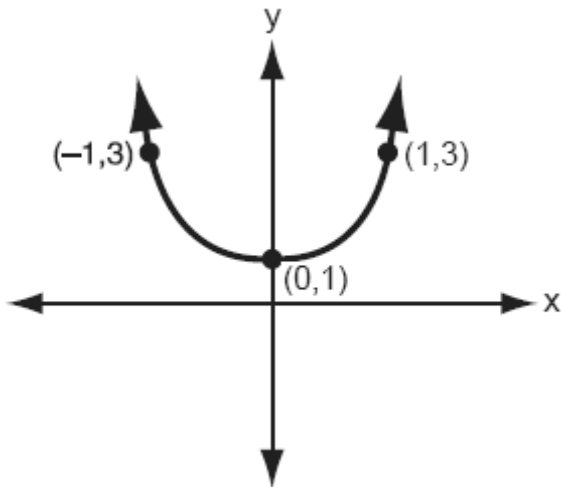

- [A] $y = 2x^2 + 1$ [B] $y = 2x^2$
[C] $y = x^2$ [D] $y = 2(x^2 + 1)$

CHAPTER 7-3

429. 080508a, P.I. A.A.8
The height of a golf ball hit into the air is modeled by the equation $h = -16t^2 + 48t$, where h represents the height, in feet, and t represents the number of seconds that have passed since the ball was hit. What is the height of the ball after 2 seconds?
- [A] 32 ft [B] 16 ft [C] 80 ft [D] 64 ft

430. 080017a, P.I. A.G.4
Which is an equation of the parabola shown in the accompanying diagram?

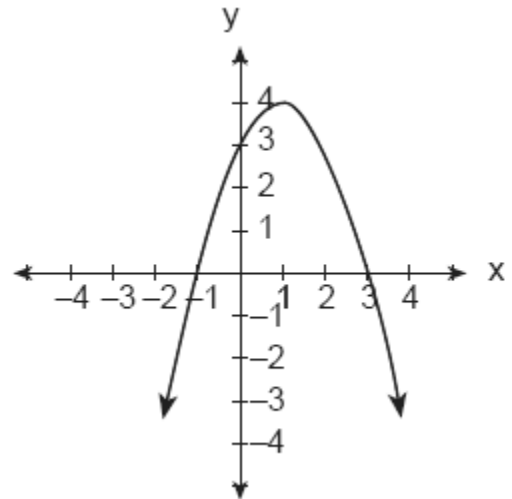

- [A] $y = x^2 - 2x + 3$ [B] $y = -x^2 - 2x + 3$
[C] $y = x^2 + 2x + 3$ [D] $y = -x^2 + 2x + 3$

431. 010303b, P.I. A.G.4
Which equation represents the parabola shown in the accompanying graph?

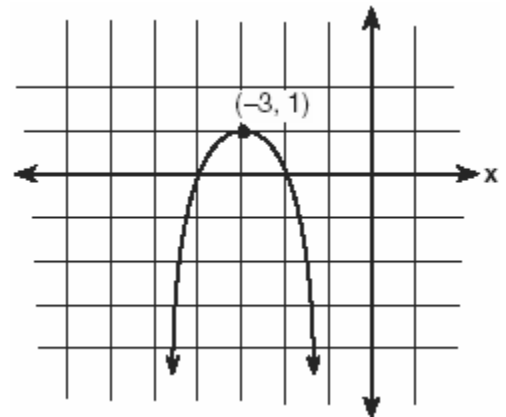

- [A] $f(x) = (x + 1)^2 - 3$
[B] $f(x) = -(x + 3)^2 + 1$
[C] $f(x) = -(x - 3)^2 - 3$
[D] $f(x) = -(x - 3)^2 + 1$

432. 010328a, P.I. A.G.4

The graph of a quadratic equation is shown in the accompanying diagram. The scale on the axes is a unit scale. Write an equation of this graph in standard form.

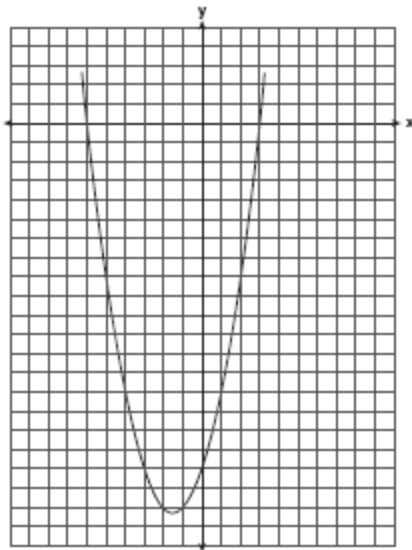

433. 010606b, P.I. A.G.10

Which is an equation of the line of symmetry for the parabola in the accompanying diagram?

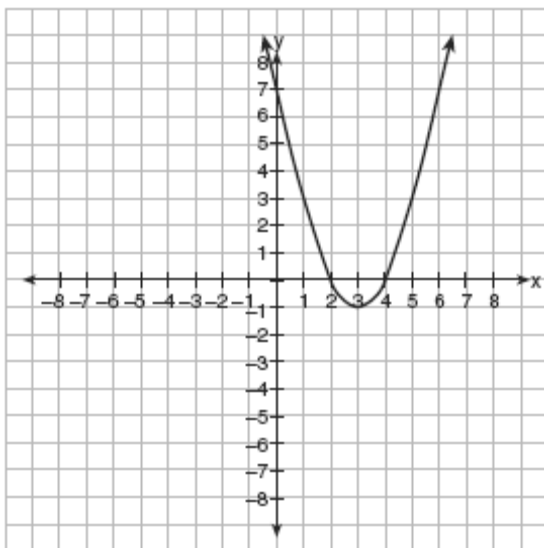

- [A] $x = 3$ [B] $x = 2$
[C] $x = 4$ [D] $y = 3$

434. 060514b, P.I. A.A.41

For which quadratic equation is the axis of symmetry $x = 3$?

- [A] $y = x^2 + x + 3$ [B] $y = x^2 + 6x + 3$
[C] $y = -x^2 + 6x + 2$ [D] $y = -x^2 + 3x + 5$

435. 060611b, P.I. A.A.41

The graph of $y = (x - 3)^2$ is shifted left 4 units and down 2 units. What is the axis of symmetry of the transformed graph?

- [A] $x = -2$ [B] $x = 7$
[C] $x = -1$ [D] $x = 1$

436. 080234a, P.I. A.A.27

Greg is in a car at the top of a roller-coaster ride. The distance, d , of the car from the ground as the car descends is determined by the equation $d = 144 - 16t^2$, where t is the number of seconds it takes the car to travel down to each point on the ride. How many seconds will it take Greg to reach the ground?

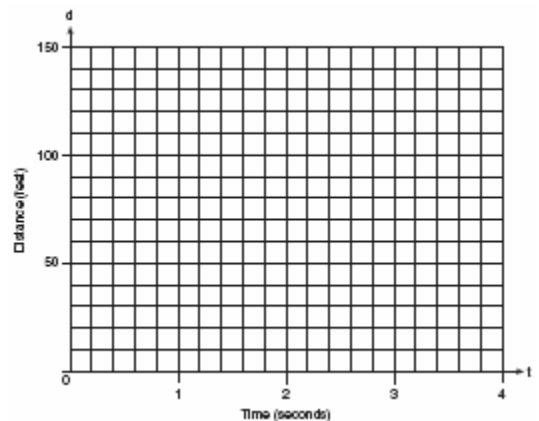

437. 010431b, P.I. A2.A.7

An acorn falls from the branch of a tree to the ground 25 feet below. The distance, S , the acorn is from the ground as it falls is represented by the equation

$S(t) = -16t^2 + 25$, where t represents time, in seconds. Sketch a graph of this situation on the accompanying grid. Calculate, to the nearest hundredth of a second, the time the acorn will take to reach the ground.

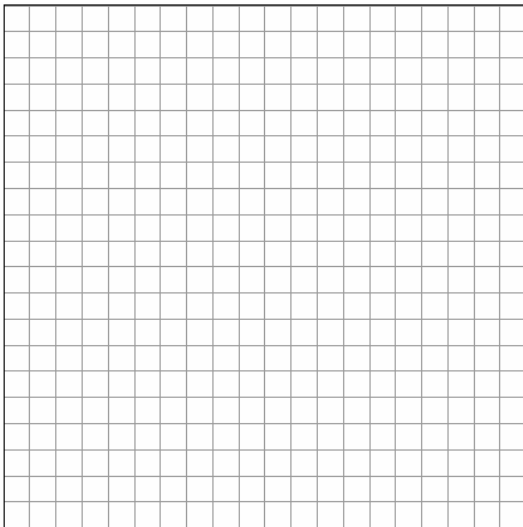

MINIMUM AND MAXIMUM OF QUADRATICS

438. 010031a, P.I. A.G.4

Amy tossed a ball in the air in such a way that the path of the ball was modeled by the equation $y = -x^2 + 6x$. In the equation, y represents the height of the ball in feet and x is the time in seconds.

a Graph $y = -x^2 + 6x$ for $0 \leq x \leq 6$ on the grid provided below.

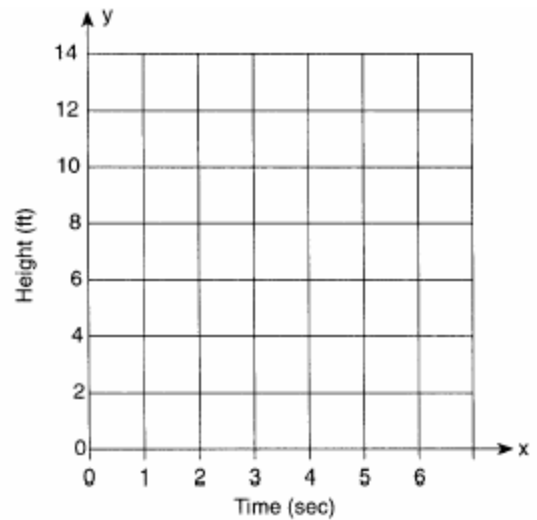

b At what time, x , is the ball at its highest point?

439. 060333a, P.I. A.G.4

An architect is designing a museum entranceway in the shape of a parabolic arch represented by the equation $y = -x^2 + 20x$, where $0 \leq x \leq 20$ and all dimensions are expressed in feet. On the accompanying set of axes, sketch a graph of the arch and determine its maximum height, in feet.

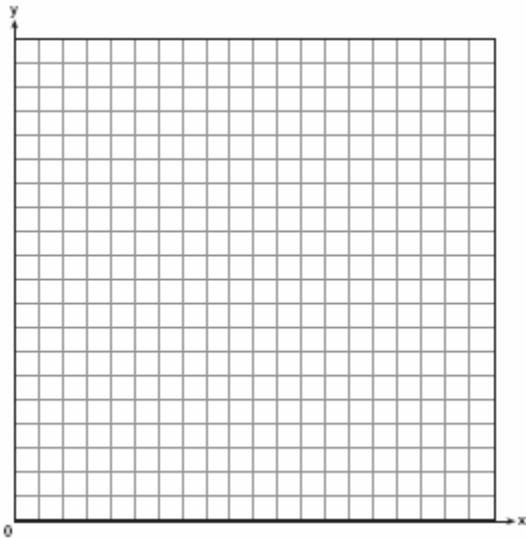

440. 010439a, P.I. A.G.4

Tom throws a ball into the air. The ball travels on a parabolic path represented by the equation $h = -8t^2 + 40t$, where h is the height, in feet, and t is the time, in seconds.
a On the accompanying set of axes, graph the equation from $t = 0$ to $t = 5$ seconds, including all integral values of t from 0 to 5.

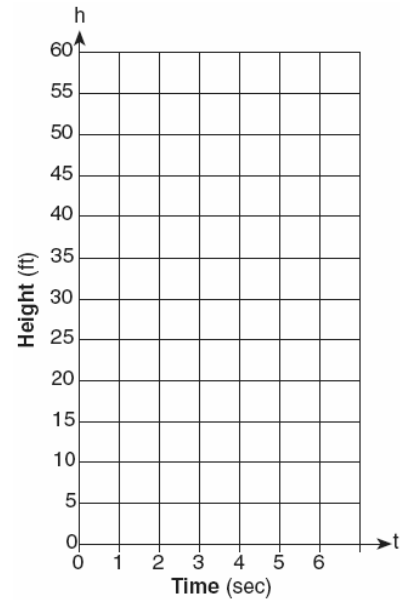

b What is the value of t at which h has its greatest value?

441. 089933a, P.I. A.G.4
An arch is built so that it is 6 feet wide at the base. Its shape can be represented by a parabola with the equation $y = -2x^2 + 12x$, where y is the height of the arch.
a Graph the parabola from $x = 0$ to $x = 6$ on the grid below.

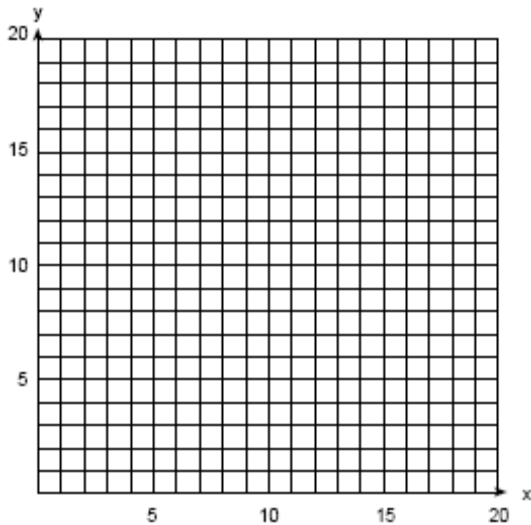

- b Determine the maximum height, y , of the arch.

CHAPTER 7-4

SQUARE ROOTS

442. 010001a, P.I. 7.N.18
The expression $\sqrt{93}$ is a number between
[A] 8 and 9 [B] 3 and 9
[C] 46 and 47 [D] 9 and 10
443. 010703a, P.I. 7.N.18
Which point on the accompanying number line best represents the position of $\sqrt{5}$?



- [A] B [B] A [C] C [D] D

444. 060706a
The expression $\sqrt{54-b}$ is equivalent to a positive integer when b is equal to
[A] 16 [B] -10 [C] 54 [D] 4

445. 060502a, P.I. 7.A.6
The amount of time, t , in seconds, it takes an object to fall a distance, d , in meters, is expressed by the formula $t = \sqrt{\frac{d}{4.9}}$.
Approximately how long will it take an object to fall 75 meters?
[A] 3.9 sec [B] 0.26 sec
[C] 2.34 sec [D] 7.7 sec

CHAPTER 7-5

SOLVING QUADRATICS

446. 010215a, P.I. A.A.27
What is the solution set of the equation $3x^2 = 48$?
[A] {2,8} [B] {4,4}
[C] {-2,-8} [D] {4,-4}
447. 010808a, P.I. A.A.27
A solution of the equation $\frac{x^2}{4} = 9$ is
[A] 12 [B] 3 [C] $\frac{3}{2}$ [D] 6
448. 080733a, P.I. A.A.27
What is the positive solution of the equation $4x^2 - 36 = 0$?

CHAPTER 8-2

REGRESSION

449. 080705a, P.I. A2.S.7

The population growth of Boomtown is shown in the accompanying graph.

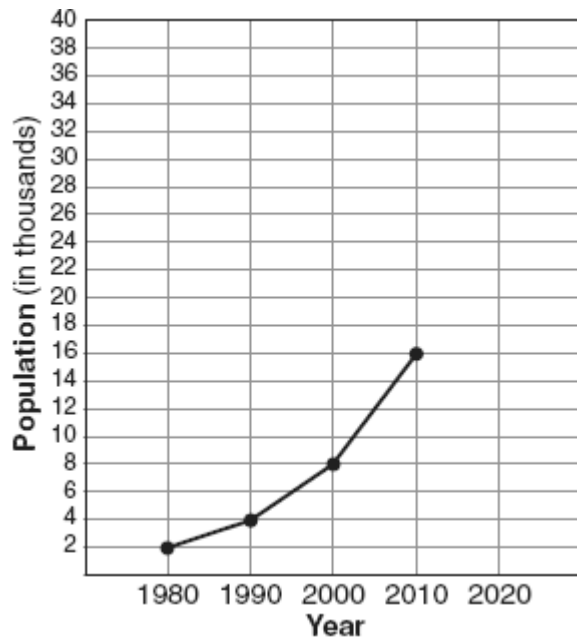

If the same pattern of population growth continues, what will the population of Boomtown be in the year 2020?

- [A] 20,000 [B] 40,000
[C] 64,000 [D] 32,000

CHAPTER 8-4

ZERO AND NEGATIVE POWERS

450. 060020a, P.I. A2.A.8

What is the value of 3^{-2} ?

- [A] $-\frac{1}{9}$ [B] 9 [C] $\frac{1}{9}$ [D] -9

451. 080522a, P.I. A2.A.8

What is the value of 2^{-3} ?

- [A] $\frac{1}{6}$ [B] -6 [C] $\frac{1}{8}$ [D] -8

452. 010723a, P.I. A2.A.8

What is the value of $3^0 + 3^{-2}$?

- [A] 0 [B] $1\frac{1}{9}$ [C] $\frac{1}{9}$ [D] 6

453. 080730a, P.I. A2.A.8

The expression $(\frac{3}{4})^2 \cdot (\frac{1}{4})^{-2}$ is equivalent to

- [A] 9 [B] $\frac{9}{16}$ [C] $\frac{9}{256}$ [D] 3

454. 080119a, P.I. A2.A.9

Which expression is equivalent to $x^{-1} \cdot y^2$?

- [A] xy^2 [B] $\frac{y^2}{x}$ [C] $\frac{x}{y^2}$ [D] xy^{-2}

455. 010511a, P.I. A2.A.9

Which expression is equivalent to x^{-4} ?

- [A] $\frac{1}{x^4}$ [B] x^4 [C] $-4x$ [D] 0

456. 010824b, P.I. A.A.12

Simplify the expression $(m^6)^{\frac{2}{3}}$ and write your answer using a positive exponent.

457. 080423b

Solve for x : $x^{-3} = \frac{27}{64}$

CHAPTER 8-5

SCIENTIFIC NOTATION

458. 080004a, P.I. 7.N.6
Expressed in decimal notation, 4.726×10^{-3} is
[A] 0.004726 [B] 4,726
[C] 0.04726 [D] 472.6
459. 060301a, P.I. 7.N.6
The number 8.375×10^{-3} is equivalent to
[A] 0.08375 [B] 8,375
[C] 0.008375 [D] 0.0008375
460. 080424a, P.I. 7.N.6
The number 1.56×10^{-2} is equivalent to
[A] 156 [B] 0.0156
[C] 0.00156 [D] 0.156
461. 080511a, P.I. 7.N.5
The expression 0.62×10^3 is equivalent to
[A] 62,000 [B] 0.062
[C] 6.2×10^4 [D] 6.2×10^2
462. 089904a, P.I. 7.N.7
Which expression is equivalent to 6.02×10^{23} ?
[A] 602×10^{21} [B] 0.602×10^{21}
[C] 60.2×10^{21} [D] 6020×10^{21}
463. 080210a, P.I. 7.N.5
If 0.0347 is written by a scientist in the form 3.47×10^n , the value of n is
[A] -3 [B] 3 [C] -2 [D] 2
464. 060720a, P.I. 7.N.5
According to the 2000 census, the population of New York State was approximately 18,900,000. How is this number expressed in scientific notation?
[A] 18.9×10^6 [B] 1.89×10^7
[C] 1890×10^4 [D] 189×10^5
465. 010111a, P.I. 7.N.5
The distance from Earth to the Sun is approximately 93 million miles. A scientist would write that number as
[A] 93×10^7 [B] 93×10^{10}
[C] 9.3×10^6 [D] 9.3×10^7
466. 080715a, P.I. 7.N.5
The video of the movie *Star Wars* earned \$193,500,000 in rental fees during its first year. Expressed in scientific notation, the number of dollars earned is
[A] 1935×10^6 [B] 1935×10^8
[C] 1.935×10^6 [D] 1.935×10^8
467. 080607a, P.I. 7.N.5
A micron is a unit used to measure specimens viewed with a microscope. One micron is equivalent to 0.00003937 inch. How is this number expressed in scientific notation?
[A] 3.937×10^{-5} [B] 3.937×10^5
[C] 3937×10^{-8} [D] 3937×10^8
468. 010206a, P.I. 7.N.5
The approximate number of seconds in a year is 32,000,000. When this number is written in scientific notation, the numerical value of the exponent is
[A] 8 [B] 7 [C] -7 [D] 6

469. 060504a, P.I. 7.N.5
The mass of an orchid seed is approximately 0.0000035 gram. Written in scientific notation, that mass is equivalent to 3.5×10^n . What is the value of n ?

[A] -7 [B] -6 [C] -5 [D] -8

470. 010609a, P.I. 7.N.5
The size of a certain type of molecule is 0.00009078 inch. If this number is expressed as 9.078×10^n , what is the value of n ?

[A] 8 [B] 5 [C] -5 [D] -8

471. 060628a
What is the sum of 6×10^3 and 3×10^2 ?

[A] 6.3×10^3 [B] 18×10^5
[C] 9×10^5 [D] 9×10^6

472. 060207a, P.I. A.N.4
If 3.85×10^6 is divided by 385×10^4 , the result is

[A] 0.01 [B] 1
[C] 3.85×10^{10} [D] 3.85×10^4

473. 010319a, P.I. A.N.4
What is the value of $\frac{6.3 \times 10^8}{3 \times 10^4}$ in scientific notation?

[A] 2.1×10^2 [B] 2.1×10^4
[C] 2.1×10^{-2} [D] 2.1×10^{-4}

474. fall0725ia, P.I. A.N.4
What is the quotient of 8.05×10^6 and 3.5×10^2 ?

[A] 2.3×10^{12} [B] 2.3×10^4
[C] 2.3×10^3 [D] 2.3×10^8

475. 010018a, P.I. A.N.4
If the number of molecules in 1 mole of a substance is 6.02×10^{23} , then the number of molecules in 100 moles is

[A] 6.02×10^{22} [B] 6.02×10^{25}
[C] 6.02×10^{21} [D] 6.02×10^{24}

476. 060429a, P.I. A.N.4
If the mass of a proton is 1.67×10^{-24} gram, what is the mass of 1,000 protons?

[A] 1.67×10^{-23} [B] 1.67×10^{-22}
[C] 1.67×10^{-21} [D] 1.67×10^{-27}

CHAPTER 8-6

OPERATIONS WITH POWERS

477. 010413a, P.I. A.A.12
The expression $8^{-4} \cdot 8^6$ is equivalent to

[A] 8^{-24} [B] 8^{-2} [C] 8^{10} [D] 8^2

478. 060312a, P.I. A.A.12
The expression $3^2 \cdot 3^3 \cdot 3^4$ is equivalent to

[A] 3^9 [B] 27^9 [C] 3^{24} [D] 27^{24}

479. 069911a, P.I. A.A.12
The expression $2^3 \cdot 4^2$ is equivalent to

[A] 8^6 [B] 2^{12} [C] 2^7 [D] 8^5

480. 010008a, P.I. A.A.12
The expression $(x^2z^3)(xy^2z)$ is equivalent to

[A] $x^3y^2z^4$ [B] $x^4y^2z^5$
[C] $x^3y^3z^4$ [D] $x^2y^2z^3$

481. 080001a, P.I. A.A.12
The product of $2x^3$ and $6x^5$ is

[A] $10x^{15}$ [B] $10x^8$
[C] $12x^{15}$ [D] $12x^8$

482. 010205a, P.I. A.A.12
The product of $3x^2y$ and $-4xy^3$ is
[A] $-12x^3y^4$ [B] $12x^3y^4$
[C] $-12x^2y^3$ [D] $12x^2y^3$
483. 010306a, P.I. A.A.12
The product of $3x^5$ and $2x^4$ is
[A] $6x^{20}$ [B] $5x^{20}$ [C] $5x^9$ [D] $6x^9$
484. 089906a, P.I. A.A.12
The product of $4x^2y$ and $2xy^3$ is
[A] $8x^2y^3$ [B] $8x^3y^4$
[C] $8x^3y^3$ [D] $8x^2y^4$
485. 080605a, P.I. A.A.12
What is the product of $10x^4y^2$ and $3xy^3$?
[A] $30x^5y^6$ [B] $30x^5y^5$
[C] $30x^4y^5$ [D] $30x^4y^6$
486. 060604a, P.I. A.A.12
What is the product of $\frac{1}{3}x^2y$ and $\frac{1}{6}xy^3$?
[A] $\frac{1}{9}x^3y^4$ [B] $\frac{1}{18}x^2y^3$
[C] $\frac{1}{2}x^2y^3$ [D] $\frac{1}{18}x^3y^4$

CHAPTER 8-7

487. 010728a, P.I. A.A.12
The expression $(6x^3y^6)^2$ is equivalent to
[A] $12x^6y^{12}$ [B] $36x^5y^8$
[C] $6x^6y^{12}$ [D] $36x^6y^{12}$
488. 010529a, P.I. A.A.12
Expressed in its simplest form,
 $(3x^3)(2y)^2(4x^4)$ is equivalent to
[A] $48x^7y^2$ [B] $24x^7y^2$
[C] $48x^{12}y^2$ [D] $24x^{12}y^2$
489. 010506a, P.I. A.A.12
The product of $(5ab)$ and $(-2a^2b)^3$ is
[A] $-40a^7b^4$ [B] $-40a^6b^4$
[C] $-30a^7b^4$ [D] $-30a^6b^4$
- ## CHAPTER 8-8
490. 080405a, P.I. A.A.12
When $-9x^5$ is divided by $-3x^3$, $x \neq 0$, the
quotient is
[A] $3x^2$ [B] $-3x^2$
[C] $27x^8$ [D] $-27x^{15}$
491. 060005a, P.I. A.A.12
The quotient of $-\frac{15x^8}{5x^2}$, $x \neq 0$, is
[A] $-10x^6$ [B] $-3x^6$
[C] $-10x^4$ [D] $-3x^4$
492. 060707a, P.I. A.A.12
The expression $\frac{-32x^8}{4x^2}$, $x \neq 0$, is equivalent
to
[A] $-8x^4$ [B] $8x^4$
[C] $8x^6$ [D] $-8x^6$
493. 060518a, P.I. A.A.12
If $x \neq 0$, then $\frac{(x^2)^3}{x^5} \cdot 1000$ is equivalent to
[A] $1000x$ [B] $1000 + x$
[C] 1000 [D] 0

494. 080526a, P.I. A.A.12

The expression $\frac{5x^6y^2}{x^8y}$ is equivalent to

- [A] $\frac{5y^3}{x^{14}}$ [B] $5x^{14}y^3$
[C] $\frac{5y}{x^2}$ [D] $5x^2y$

495. 010817a, P.I. A.A.12

The expression $\frac{4x^2y^3}{2xy^4}$ is equivalent to

- [A] $\frac{2y}{x}$ [B] $-2xy$ [C] $2xy$ [D] $\frac{2x}{y}$

496. fall0703ia, P.I. A.A.12

Which expression represents $\frac{(2x^3)(8x^5)}{4x^6}$ in simplest form?

- [A] x^2 [B] x^9 [C] $4x^2$ [D] $4x^9$

497. 080415b, P.I. A.A.12

The expression $\frac{(b^{2n+1})^3}{b^n \cdot b^{4n+3}}$ is equivalent to

- [A] b^{-3n} [B] b^n [C] $\frac{b^n}{2}$ [D] b^{-3n+1}

499. 010827a, P.I. G.G.48

Which set of numbers could be the lengths of the sides of a right triangle?

- [A] {10,24,26} [B] {4,7,8}
[C] {12,16,30} [D] {3,4,6}

500. 010615a, P.I. G.G.48

A builder is building a rectangular deck with dimensions of 16 feet by 30 feet. To ensure that the sides form 90° angles, what should each diagonal measure?

- [A] 30 ft [B] 46 ft [C] 34 ft [D] 16 ft

501. 010202a, P.I. A.A.45

If the length of the legs of a right triangle are 5 and 7, what is the length of the hypotenuse?

- [A] $2\sqrt{3}$ [B] $2\sqrt{6}$
[C] $\sqrt{2}$ [D] $\sqrt{74}$

502. 060710a, P.I. A.A.45

If the length of a rectangular television screen is 20 inches and its height is 15 inches, what is the length of its diagonal, in inches?

- [A] 13.2 [B] 5 [C] 25 [D] 35

CHAPTER 9-1

PYTHAGORAS

498. 060009a, P.I. G.G.48

The set of integers {3,4,5} is a Pythagorean triple. Another such set is

- [A] {8,15,17} [B] {6,8,12}
[C] {6,7,8} [D] {6,12,13}

503. fall0711ia, P.I. A.A.45

Tanya runs diagonally across a rectangular field that has a length of 40 yards and a width of 30 yards, as shown in the diagram below.

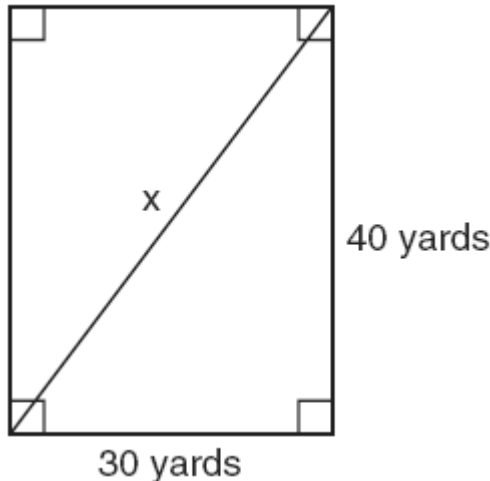

What is the length of the diagonal, in yards, that Tanya runs?

- [A] 50 [B] 70 [C] 60 [D] 80

504. 010736a, P.I. G.G.48

The perimeter of a square is 56. Express the length of a diagonal of the square in simplest radical form.

505. 010508a, P.I. A.A.45

The NuFone Communications Company must run a telephone line between two poles at opposite ends of a lake, as shown in the accompanying diagram. The length and width of the lake are 75 feet and 30 feet, respectively.

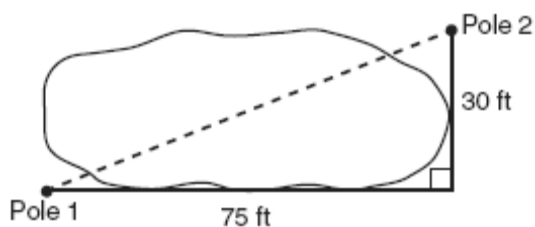

What is the distance between the two poles, to the nearest foot?

- [A] 69 [B] 105 [C] 81 [D] 45

506. 010023a, P.I. A.A.45

A wall is supported by a brace 10 feet long, as shown in the diagram below. If one end of the brace is placed 6 feet from the base of the wall, how many feet up the wall does the brace reach?

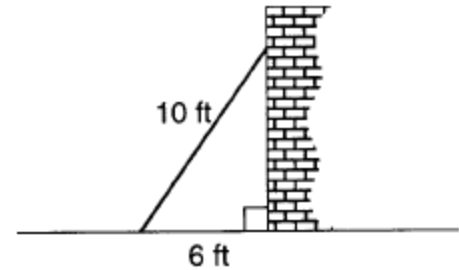

507. 080531a, P.I. A.A.45

The accompanying diagram shows a kite that has been secured to a stake in the ground with a 20-foot string. The kite is located 12 feet from the ground, directly over point X. What is the distance, in feet, between the stake and point X?

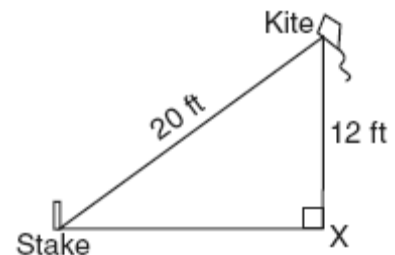

508. 080122a, P.I. A.A.45

How many feet from the base of a house must a 39-foot ladder be placed so that the top of the ladder will reach a point on the house 36 feet from the ground?

509. 060115a, P.I. A.A.45

A woman has a ladder that is 13 feet long. If she sets the base of the ladder on level ground 5 feet from the side of a house, how many feet above the ground will the top of the ladder be when it rests against the house?

- [A] 8 [B] 9 [C] 12 [D] 11

510. 080707a, P.I. A.A.45
A cable 20 feet long connects the top of a flagpole to a point on the ground that is 16 feet from the base of the pole. How tall is the flagpole?

[A] 12 ft [B] 26 ft [C] 8 ft [D] 10 ft

511. 080633a, P.I. A.A.45
In the accompanying diagram of right triangles ABD and DBC , $AB = 5$, $AD = 4$, and $CD = 1$. Find the length of \overline{BC} , to the nearest tenth.

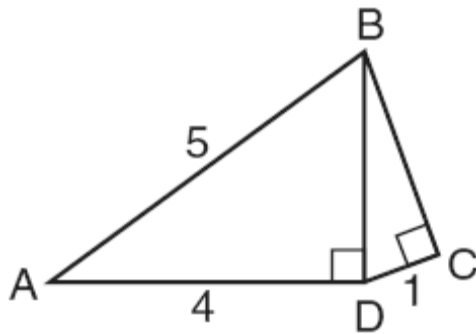

512. 060230a, P.I. G.G.48
In the accompanying diagram, triangle A is similar to triangle B. Find the value of n .

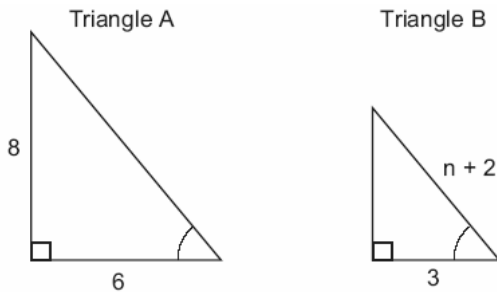

513. 060334a, G.G.48
A straw is placed into a rectangular box that is 3 inches by 4 inches by 8 inches, as shown in the accompanying diagram. If the straw fits exactly into the box diagonally from the bottom left front corner to the top right back corner, how long is the straw, to the nearest tenth of an inch?

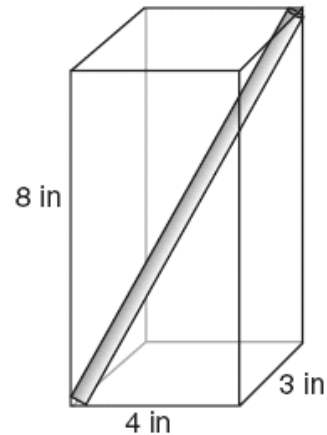

514. 080504b, P.I. G.G.48
The accompanying diagram shows two cables of equal length supporting a pole. Both cables are 14 meters long, and they are anchored to points in the ground that are 14 meters apart.

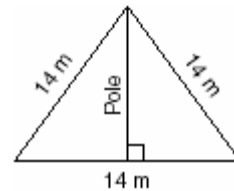

What is the exact height of the pole, in meters?

[A] $7\sqrt{3}$ [B] 14 [C] 7 [D] $7\sqrt{2}$

515. 080726b, P.I. G.G.48

The accompanying diagram shows ramp \overline{RA} leading to level platform \overline{AM} , forming an angle of 45° with level ground. If platform \overline{AM} measures 2 feet and is 6 feet above the ground, explain why the exact length of ramp \overline{RA} is $6\sqrt{2}$ feet.

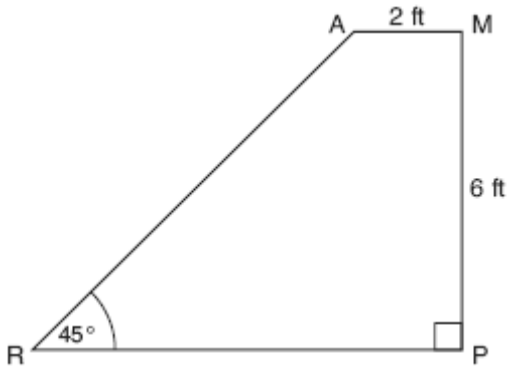

516. 080124b P.I. G.G.48

The accompanying diagram shows a semicircular arch over a street that has a radius of 14 feet. A banner is attached to the arch at points A and B , such that $AE = EB = 5$ feet. How many feet above the ground are these points of attachment for the banner?

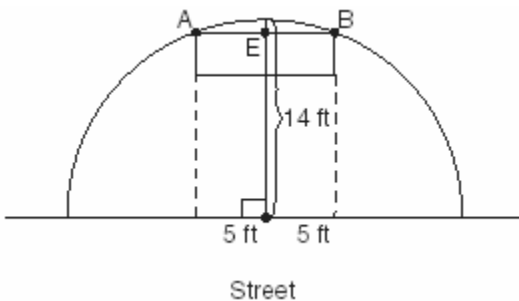

CHAPTER 9-2

DISTANCE

517. 010524a, P.I. G.G.67

The coordinates of point R are $(-3,2)$ and the coordinates of point T are $(4,1)$. What is the length of \overline{RT} ?

[A] $2\sqrt{2}$ [B] $\sqrt{10}$

[C] $4\sqrt{3}$ [D] $5\sqrt{2}$

518. 080726a, P.I. G.G.67

What is the length of the line segment that joins the points whose coordinates are $(4,7)$ and $(-3,5)$?

[A] $\sqrt{193}$ [B] $\sqrt{53}$

[C] $\sqrt{5}$ [D] $3\sqrt{6}$

519. 080030a

Katrina hikes 5 miles north, 7 miles east, and then 3 miles north again. To the *nearest tenth of a mile*, how far, in a straight line, is Katrina from her starting point?

520. 060330a

To get from his high school to his home, Jamal travels 5.0 miles east and then 4.0 miles north. When Sheila goes to her home from the same high school, she travels 8.0 miles east and 2.0 miles south. What is the measure of the shortest distance, to the nearest tenth of a mile, between Jamal's home and Sheila's home? [The use of the accompanying grid is optional.]

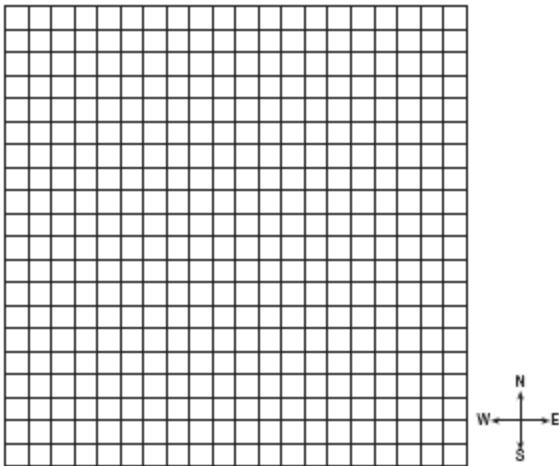

521. 060633a

Two hikers started at the same location. One traveled 2 miles east and then 1 mile north. The other traveled 1 mile west and then 3 miles south. At the end of their hikes, how many miles apart are the two hikers? [The use of the accompanying grid is optional.]

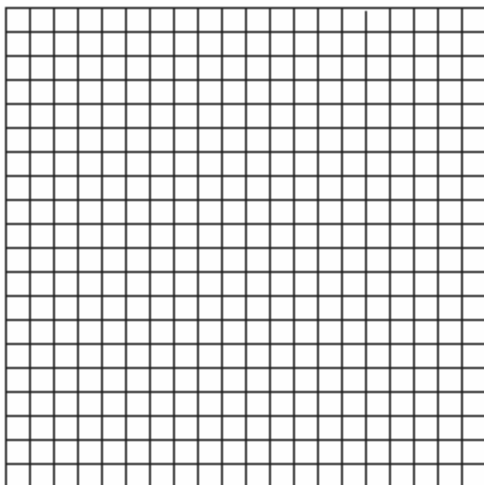

522. 010226a, P.I. G.G.67

Jerry and Jean Jogger start at the same time from point A shown on the accompanying set of axes. Jerry jogs at a rate of 5 miles per hour traveling from point A to point R to point S and then to point C. Jean jogs directly from point A to point C on \overline{AC} at the rate of 3 miles per hour. Which jogger reaches point C first? Explain or show your reasoning.

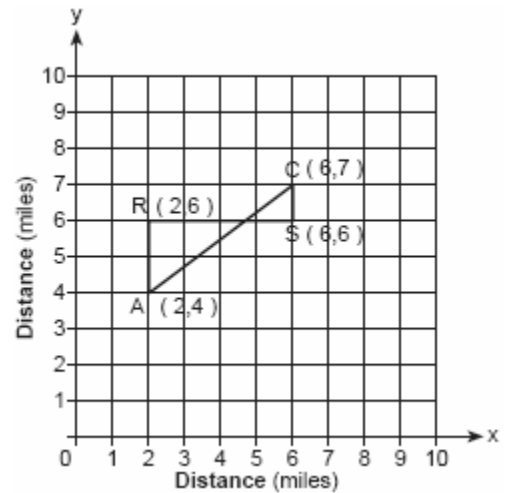

523. 080235a, P.I. G.G.68

Determine the distance between point $A(-1, -3)$ and point $B(5, 5)$. Write an equation of the perpendicular bisector of \overline{AB} . [The use of the accompanying grid is optional.]

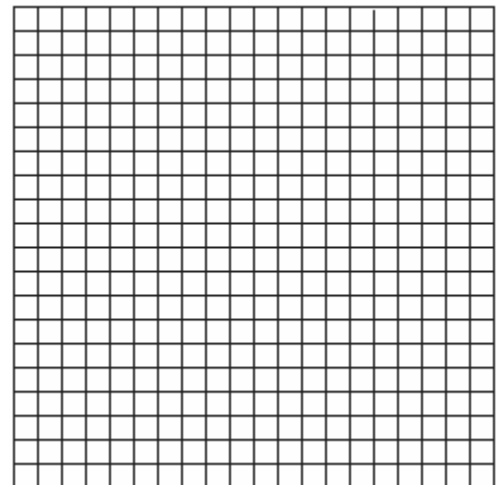

MIDPOINT

524. 060434a

The coordinates of the midpoint of \overline{AB} are (2,4), and the coordinates of point B are (3,7). What are the coordinates of point A ? [The use of the accompanying grid is optional.]

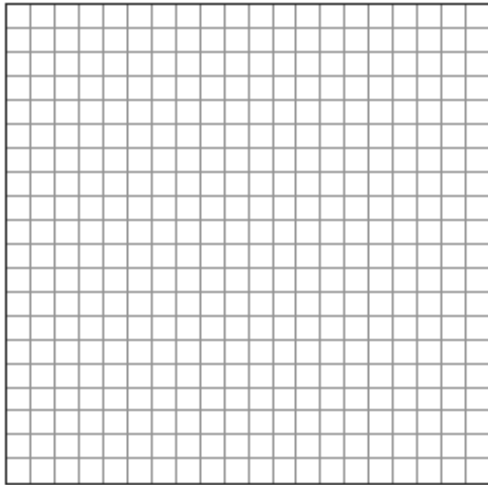

525. 080217a

M is the midpoint of \overline{AB} . If the coordinates of A are (-1,5) and the coordinates of M are (3,3), what are the coordinates of B ?

- [A] (2,8) [B] (7,1)
[C] (-5,7) [D] (1,4)

526. 010718a

The midpoint of \overline{AB} is (-1,5) and the coordinates of point A are (-3,2). What are the coordinates of point B ?

- [A] (-5,8) [B] (1,10)
[C] (0,7) [D] (1,8)

527. 080515a

A line segment on the coordinate plane has endpoints (2,4) and (4,y). The midpoint of the segment is point (3,7). What is the value of y ?

- [A] 11 [B] 10 [C] -2 [D] 5

528. 080624a, P.I. G.G.66

The coordinates of A are (-9, 2) and the coordinates of G are (3, 14). What are the coordinates of the midpoint of \overline{AG} ?

- [A] (-21,-10) [B] (-6,6)
[C] (-3,8) [D] (-6,16)

529. 010021a

The midpoint M of line segment AB has coordinates (-3,4). If point A is the origin, (0,0), what are the coordinates of point B ? [The use of the accompanying grid is optional.]

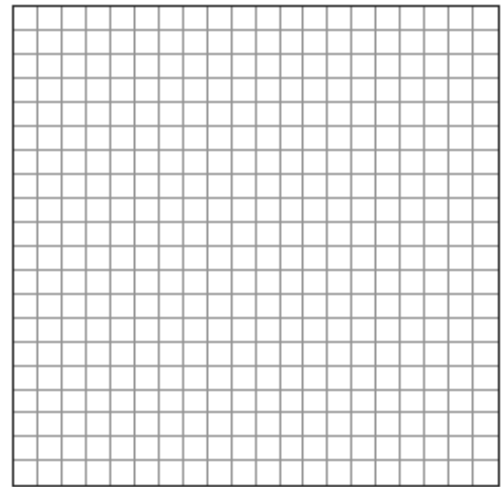

CHAPTER 9-3

BASIC TRIGONOMETRIC RATIOS

530. fall0721ia, P.I. A.A.42

In triangle MCT , the measure of $\angle T = 90^\circ$, $MC = 85$ cm, $CT = 84$ cm, and $TM = 13$ cm. Which ratio represents the sine of $\angle C$?

- [A] $\frac{84}{85}$ [B] $\frac{13}{85}$ [C] $\frac{84}{13}$ [D] $\frac{13}{84}$

531. 080414a, P.I. A.A.42

Which ratio represents $\cos A$ in the accompanying diagram of $\triangle ABC$?

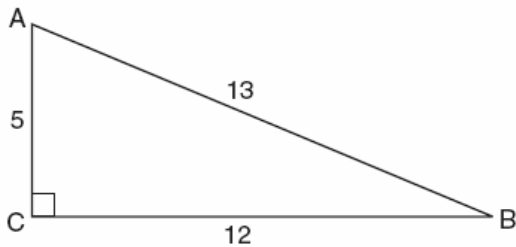

- [A] $\frac{5}{13}$ [B] $\frac{13}{5}$ [C] $\frac{12}{13}$ [D] $\frac{12}{5}$

532. 010316a, P.I. A.A.42

In the accompanying diagram of right triangle ABC , $AB = 8$, $BC = 15$, $AC = 17$, and $m\angle ABC = 90$.

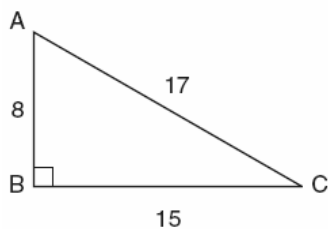

What is $\tan \angle C$?

- [A] $\frac{15}{17}$ [B] $\frac{8}{15}$ [C] $\frac{8}{17}$ [D] $\frac{17}{15}$

533. 060419a, P.I. A.A.44

The angle of elevation from a point 25 feet from the base of a tree on level ground to the top of the tree is 30° . Which equation can be used to find the height of the tree?

- [A] $\tan 30^\circ = \frac{x}{25}$ [B] $\sin 30^\circ = \frac{x}{25}$
[C] $30^2 + 25^2 = x^2$ [D] $\cos 30^\circ = \frac{x}{25}$

534. 060030a, P.I. A.A.44

A surveyor needs to determine the distance across the pond shown in the accompanying diagram. She determines that the distance from her position to point P on the south shore of the pond is 175 meters and the angle from her position to point X on the north shore is 32° . Determine the distance, PX , across the pond, rounded to the nearest meter.

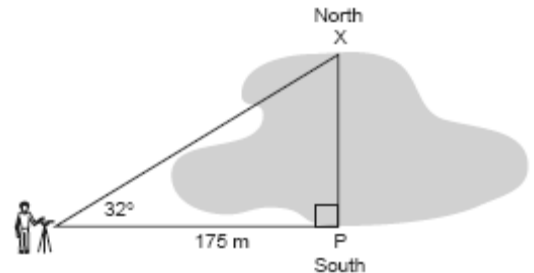

535. 069934a, P.I. A.A.44

Joe is holding his kite string 3 feet above the ground, as shown in the accompanying diagram. The distance between his hand and a point directly under the kite is 95 feet. If the angle of elevation to the kite is 50° , find the height, h , of his kite, to the nearest foot.

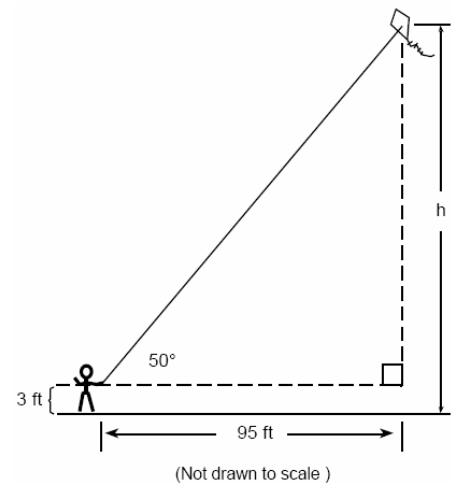

536. 080724a, P.I. A.A.44

The accompanying diagram shows a ramp 30 feet long leaning against a wall at a construction site.

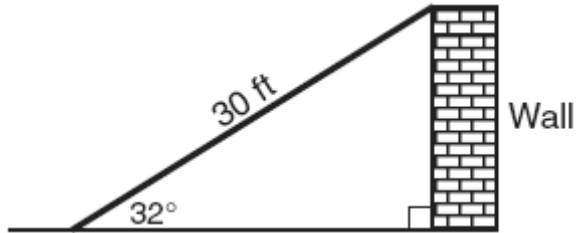

If the ramp forms an angle of 32° with the ground, how high above the ground, to the nearest tenth, is the top of the ramp?

- [A] 18.7 ft [B] 15.9 ft
[C] 56.6 ft [D] 25.4 ft

537. 010135a, P.I. A.A.44

Find, to the nearest tenth of a foot, the height of the tree represented in the accompanying diagram.

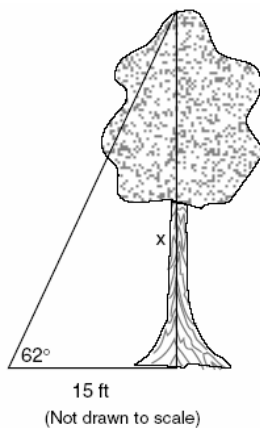

538. 010735a, P.I. A.A.44

From a point on level ground 25 feet from the base of a tower, the angle of elevation to the top of the tower is 78° , as shown in the accompanying diagram. Find the height of the tower, to the nearest tenth of a foot.

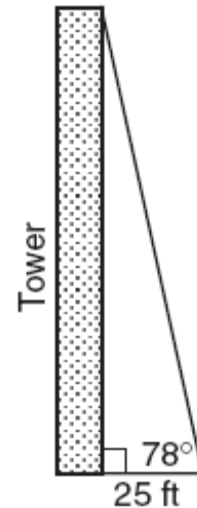

539. 010531a, P.I. A.A.44

In the accompanying diagram, a ladder leaning against a building makes an angle of 58° with level ground. If the distance from the foot of the ladder to the building is 6 feet, find, to the nearest foot, how far up the building the ladder will reach.



540. 080536a, P.I. A.A.44

A tree casts a shadow that is 20 feet long. The angle of elevation from the end of the shadow to the top of the tree is 66° . Determine the height of the tree, to the nearest foot.

541. 010235a, P.I. A.A.44

Draw and label a diagram of the path of an airplane climbing at an angle of 11° with the ground. Find, to the *nearest foot*, the ground distance the airplane has traveled when it has attained an altitude of 400 feet.

542. 080033a, P.I. A.A.44

A 10-foot ladder is to be placed against the side of a building. The base of the ladder must be placed at an angle of 72° with the level ground for a secure footing. Find, to the *nearest inch*, how far the base of the ladder should be from the side of the building and how far up the side of the building the ladder will reach.

543. 080231a, P.I. A.A.44

In the accompanying diagram, x represents the length of a ladder that is leaning against a wall of a building, and y represents the distance from the foot of the ladder to the base of the wall. The ladder makes a 60° angle with the ground and reaches a point on the wall 17 feet above the ground. Find the number of feet in x and y .

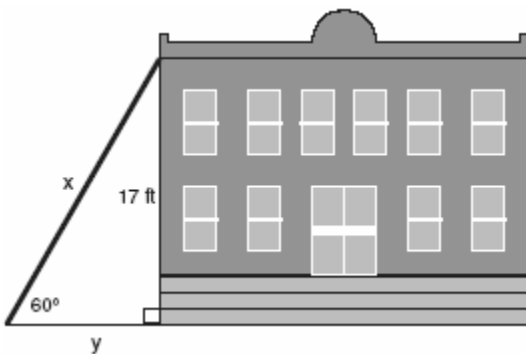

544. 010638a, P.I. A.A.44

As shown in the accompanying diagram, a ladder is leaning against a vertical wall, making an angle of 70° with the ground and reaching a height of 10.39 feet on the wall. Find, to the *nearest foot*, the length of the ladder. Find, to the *nearest foot*, the distance from the base of the ladder to the wall.

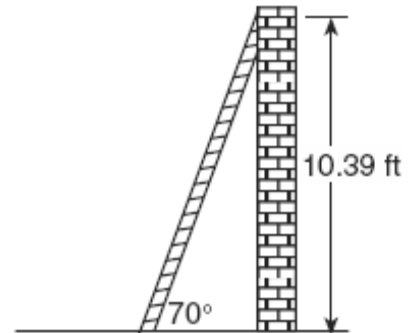

545. 089927a, P.I. A.A.43

A person standing on level ground is 2,000 feet away from the foot of a 420-foot-tall building, as shown in the accompanying diagram. To the *nearest degree*, what is the value of x ?

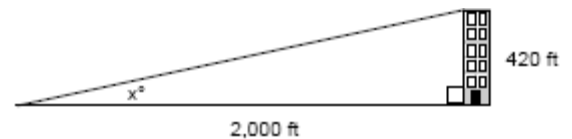

546. 060735a, P.I. A.A.43

Ron and Francine are building a ramp for performing skateboard stunts, as shown in the accompanying diagram. The ramp is 7 feet long and 3 feet high. What is the measure of the angle, x , that the ramp makes with the ground, to the *nearest tenth of a degree*?

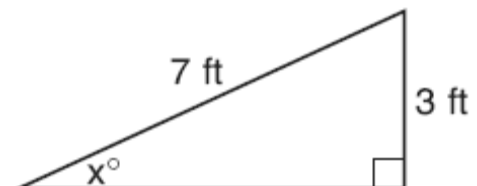

547. 060231a, P.I. A.A.43, G.G.48

As seen in the accompanying diagram, a person can travel from New York City to Buffalo by going north 170 miles to Albany and then west 280 miles to Buffalo.

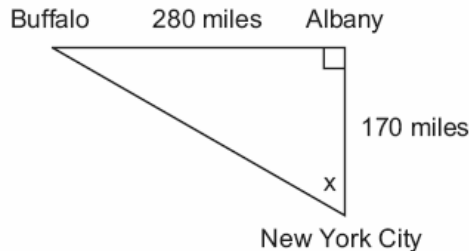

a If an engineer wants to design a highway to connect New York City directly to Buffalo, at what angle, x , would she need to build the highway? Find the angle to the *nearest degree*.

b To the *nearest mile*, how many miles would be saved by traveling directly from New York City to Buffalo rather than by traveling first to Albany and then to Buffalo?

548. 010438a, P.I. A.A.43

In the accompanying diagram, the base of a 15-foot ladder rests on the ground 4 feet from a 6-foot fence.

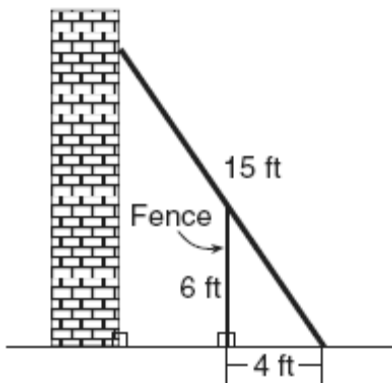

a If the ladder touches the top of the fence and the side of a building, what angle, to the *nearest degree*, does the ladder make with the ground?

b Using the angle found in part a, determine how far the top of the ladder reaches up the side of the building, to the *nearest foot*.

549. 060539a, P.I. A.A.43

The accompanying diagram shows a flagpole that stands on level ground. Two cables, r and s , are attached to the pole at a point 16 feet above the ground. The combined length of the two cables is 50 feet. If cable r is attached to the ground 12 feet from the base of the pole, what is the measure of the angle, x , to the *nearest degree*, that cable s makes with the ground?

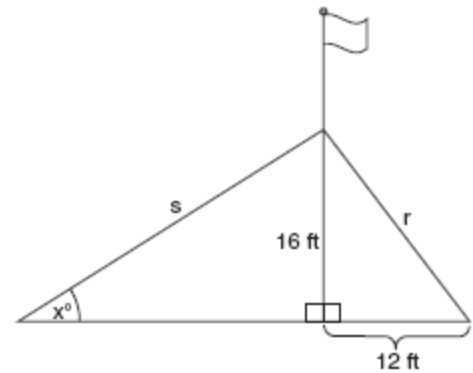

550. 080133a, P.I. A.A.44

A ship on the ocean surface detects a sunken ship on the ocean floor at an angle of depression of 50° . The distance between the ship on the surface and the sunken ship on the ocean floor is 200 meters. If the ocean floor is level in this area, how far above the ocean floor, to the *nearest meter*, is the ship on the surface?

551. 060639a, P.I. A.A.44

A person measures the angle of depression from the top of a wall to a point on the ground. The point is located on level ground 62 feet from the base of the wall and the angle of depression is 52° . How high is the wall, to the *nearest tenth of a foot*?

552. 010838a, P.I. A.A.44
A lighthouse is built on the edge of a cliff near the ocean, as shown in the accompanying diagram. From a boat located 200 feet from the base of the cliff, the angle of elevation to the top of the cliff is 18° and the angle of elevation to the top of the lighthouse is 28° . What is the height of the lighthouse, x , to the nearest tenth of a foot?

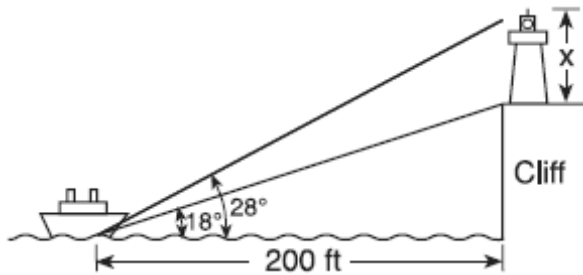

553. 080108b, P.I. A.A.44
At Mogul's Ski Resort, the beginner's slope is inclined at an angle of 12.3° , while the advanced slope is inclined at an angle of 26.4° . If Rudy skis 1,000 meters down the advanced slope while Valerie skis the same distance on the beginner's slope, how much longer was the horizontal distance that Valerie covered?
- [A] 895.7 m [B] 977.0 m
[C] 81.3 m [D] 231.6 m

CHAPTER 9-4

SIMPLIFYING RADICALS

554. 089902a, P.I. A.N.2
The expression $\sqrt{50}$ can be simplified to
- [A] $2\sqrt{25}$ [B] $25\sqrt{2}$
[C] $5\sqrt{2}$ [D] $5\sqrt{10}$
555. 010530a, P.I. A.N.2
When $\sqrt{72}$ is expressed in simplest $a\sqrt{b}$ form, what is the value of a ?
- [A] 2 [B] 8 [C] 6 [D] 3

556. fall0731ia, P.I. A.N.2
Express $5\sqrt{72}$ in simplest radical form.
557. 080125a, P.I. A2.A.13
Simplify: $\sqrt{50r^2s^4}$
558. 010422a, P.I. A2.A.13
If $a > 0$, then $\sqrt{9a^2 + 16a^2}$ equals
- [A] $5\sqrt{a}$ [B] $5a$ [C] $\sqrt{7a}$ [D] $7a$

CHAPTER 9-5

OPERATIONS WITH RADICALS

559. 060316a, P.I. A.N.3
The sum of $\sqrt{18}$ and $\sqrt{72}$ is
- [A] $9\sqrt{2}$ [B] $\sqrt{90}$
[C] $3\sqrt{10}$ [D] $6\sqrt{3}$
560. 010311a, P.I. A.N.3
The sum of $\sqrt{75}$ and $\sqrt{3}$ is
- [A] 18 [B] $\sqrt{78}$ [C] 15 [D] $6\sqrt{3}$
561. 069920a, P.I. A.N.3
The expression $\sqrt{27} + \sqrt{12}$ is equivalent to
- [A] $13\sqrt{3}$ [B] $5\sqrt{3}$
[C] $5\sqrt{6}$ [D] $\sqrt{39}$
562. 060512a, P.I. A.N.3
The expression $\sqrt{50} + \sqrt{32}$ is equivalent to
- [A] 18 [B] $9\sqrt{2}$ [C] $\sqrt{82}$ [D] 6
563. 060724a, P.I. A.N.3
The expression $\sqrt{28} + \sqrt{63}$ is equivalent to
- [A] $13\sqrt{7}$ [B] $6\sqrt{7}$
[C] $\sqrt{91}$ [D] $5\sqrt{7}$

564. 080614a, P.I. A.N.3
What is the sum of $\sqrt{50}$ and $\sqrt{32}$?
[A] $20\sqrt{20}$ [B] $\sqrt{82}$
[C] $9\sqrt{2}$ [D] $\sqrt{2}$
565. 080712a, P.I. A.N.3
What is the sum of $\sqrt{50}$ and $\sqrt{8}$?
[A] $7\sqrt{2}$ [B] $29\sqrt{2}$
[C] $9\sqrt{2}$ [D] $\sqrt{58}$
566. 080524a, P.I. A.N.3
What is the sum of $5\sqrt{7}$ and $3\sqrt{28}$?
[A] $9\sqrt{7}$ [B] $60\sqrt{7}$
[C] $8\sqrt{35}$ [D] $11\sqrt{7}$
567. 010826a, P.I. A.N.3
The expression $\sqrt{28} - \sqrt{7}$ is equivalent to
[A] 4 [B] $\sqrt{7}$ [C] $3\sqrt{7}$ [D] 2
568. 080016a, P.I. A.N.3
The expression $2\sqrt{50} - \sqrt{2}$ is equivalent to
[A] $9\sqrt{2}$ [B] 10
[C] $2\sqrt{48}$ [D] $49\sqrt{2}$
569. 060627a, P.I. A.N.3
Expressed in simplest radical form, the product of $\sqrt{6} \cdot \sqrt{15}$ is
[A] $3\sqrt{10}$ [B] $\sqrt{90}$
[C] $9\sqrt{10}$ [D] $3\sqrt{15}$
570. 010103a, P.I. A2.A.13
If $x > 0$, the expression $(\sqrt{x})(\sqrt{2x})$ is equivalent to
[A] $2x$ [B] $x^2\sqrt{2}$
[C] $x\sqrt{2}$ [D] $\sqrt{2x}$
571. 010622a, P.I. A.N.3
The expression $\frac{6\sqrt{20}}{3\sqrt{5}}$ is equivalent to
[A] $3\sqrt{15}$ [B] 8 [C] $2\sqrt{15}$ [D] 4
572. 060218a, P.I. A.N.3
The expression $\sqrt{90} \cdot \sqrt{40} - \sqrt{8} \cdot \sqrt{18}$ simplifies to
[A] 48 [B] 22.9 [C] 3,456 [D] 864
573. 080724b, P.I. A.N.3
Classical mathematics uses the term "Golden Ratio" for the ratio $(1 + \sqrt{5}):2$. The Golden Ratio was used by many famous artists to determine the dimensions of their paintings. If the ratio of the length to the width of a painting is $(1 + \sqrt{5}):2$, find the length, in feet, of a painting that has a width of 14 feet. Express your answer in simplest radical form.

CHAPTER 9-6

SOLVING RADICALS

574. 010607b, P.I. A2.A.22
If $\sqrt{2x-1} + 2 = 5$, then x is equal to
[A] 2 [B] 4 [C] 5 [D] 1
575. 080602b, P.I. A2.A.22
What is the solution of the equation $\sqrt{2x-3} - 3 = 6$?
[A] 6 [B] 42 [C] 3 [D] 39
576. 010802b, P.I. A2.A.22
What is the value of x in the equation $\sqrt{3+x} - 5 = -2$?
[A] 6 [B] 12 [C] 46 [D] 3
577. 080104b, P.I. A2.A.22
The solution set of the equation $\sqrt{x+6} = x$ is
[A] $\{-2\}$ [B] $\{-2,3\}$ [C] $\{3\}$ [D] $\{\}$

578. 010305b, P.I. A2.A.22

What is the solution set of the equation

$$\sqrt{9x+10} = x$$

[A] $\{-1\}$ [B] $\{10\}$

[C] $\{10, -1\}$ [D] $\{9\}$

579. 060214b, P.I. A2.A.22

What is the solution set of the equation

$$x = 2\sqrt{2x-3}?$$

[A] $\{2,6\}$ [B] $\{6\}$ [C] $\{2\}$ [D] $\{\}$

580. 060528b, P.I. A2.A.22

Solve for all values of q that satisfy the

$$\text{equation } \sqrt{3q+7} = q+3.$$

581. 010427b, P.I. A2.A.22

Solve algebraically: $\sqrt{x+5} + 1 = x$

582. 060629b, P.I. A2.A.22

Solve algebraically for x : $\sqrt{3x+1} + 1 = x$

583. 010323b, P.I. A2.A.22

A wrecking ball suspended from a chain is a type of pendulum. The relationship between the rate of speed of the ball, R , the mass of the ball, m , the length of the chain, L , and the

force, F , is $R = 2\pi\sqrt{\frac{mL}{F}}$. Determine the

force, F , to the *nearest hundredth*, when $L = 12$, $m = 50$, and $R = 0.6$.

584. 080528b, P.I. A2.A.22

The lateral surface area of a right circular cone, s , is represented by the equation

$s = \pi r\sqrt{r^2 + h^2}$, where r is the radius of the circular base and h is the height of the cone.

If the lateral surface area of a large funnel is 236.64 square centimeters and its radius is 4.75 centimeters, find its height, to the *nearest hundredth of a centimeter*.

585. 010532b, P.I. A2.A.22

The equation $V = 20\sqrt{C+273}$ relates speed of sound, V , in meters per second, to air temperature, C , in degrees Celsius. What is the temperature, in degrees Celsius, when the speed of sound is 320 meters per second?

[The use of the accompanying grid is optional.]

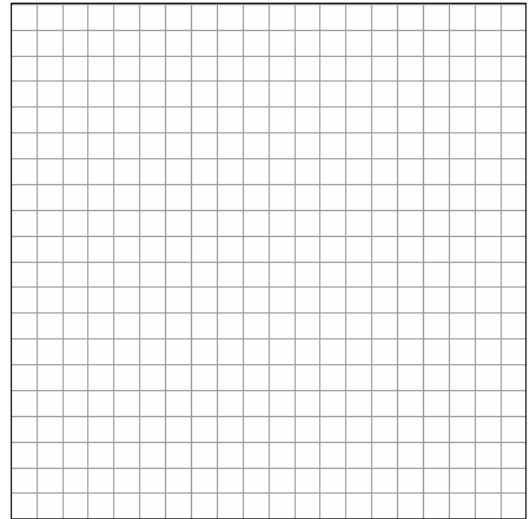

586. 010532b, P.I. A2.A.22

The number of people, y , involved in recycling in a community is modeled by the function $y = 90\sqrt{3x} + 400$, where x is the number of months the recycling plant has been open.

Construct a table of values, sketch the function on the grid, and find the number of people involved in recycling exactly 3 months after the plant opened. After how many months will 940 people be involved in recycling?

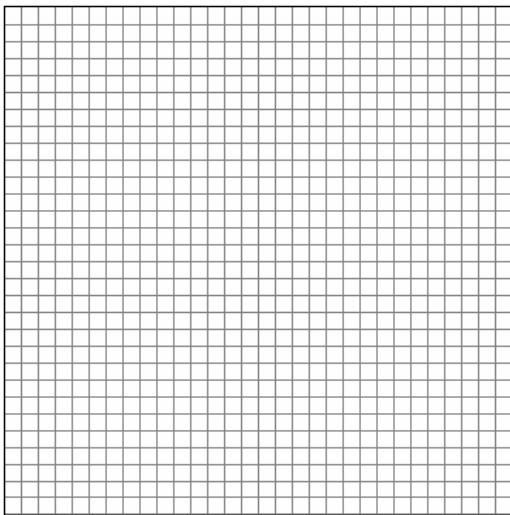

SYSTEMS

587. 060205b, P.I. A2.A.22

The path of a rocket is represented by the equation $y = \sqrt{25 - x^2}$. The path of a missile designed to intersect the path of the rocket is represented by the equation $x = \frac{3}{2}\sqrt{y}$. The value of x at the point of intersection is 3. What is the corresponding value of y ?

- [A] -4 [B] -2 [C] 4 [D] 2

MATH TOOLBOX P. 450

BOX-AND-WHISKER PLOTS

588. 060220a

The accompanying diagram is an example of which type of graph?

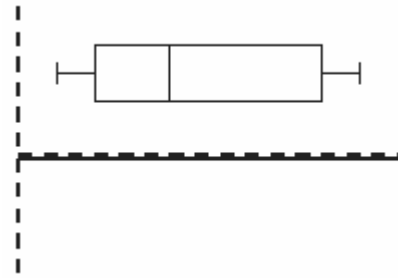

- [A] box-and-whisker plot [B] bar graph
[C] stem-and-leaf plot [D] histogram

589. 010301a, P.I. A.S.6

The accompanying diagram shows a box-and-whisker plot of student test scores on last year's Mathematics A midterm examination.

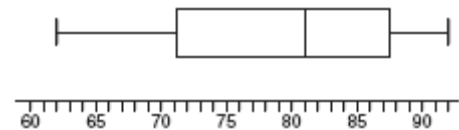

What is the median score?

- [A] 92 [B] 71 [C] 62 [D] 81

590. 060610a, P.I. A.S.6

The accompanying box-and-whisker plot represents the scores earned on a science test.

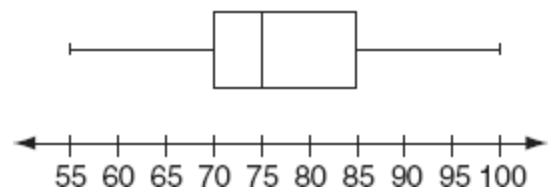

What is the median score?

- [A] 85 [B] 70 [C] 75 [D] 77

591. fall0709ia, P.I. A.S.5
The data set 5, 6, 7, 8, 9, 9, 9, 10, 12, 14, 17, 17, 18, 19, 19 represents the number of hours spent on the Internet in a week by students in a mathematics class. Which box-and-whisker plot represents the data?

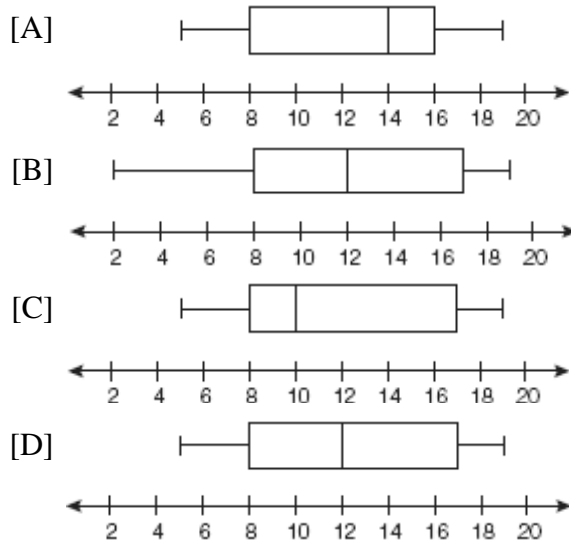

CHAPTER 10-1

OPERATIONS WITH POLYNOMIALS

592. 080710a, P.I. A.A.13
The sum of $8x^2 - x + 4$ and $x - 5$ is
[A] $8x^2 - 2x + 9$ [B] $8x^2 + 9$
[C] $8x^2 - 1$ [D] $8x^2 - 2x - 1$
593. 069904a, P.I. A.A.13
The sum of $3x^2 + x + 8$ and $x^2 - 9$ can be expressed as
[A] $4x^2 + x - 1$ [B] $3x^4 + x - 1$
[C] $4x^4 + x - 1$ [D] $4x^2 + x - 17$
594. 010108a, P.I. A.A.13
The sum of $3x^2 + 4x - 2$ and $x^2 - 5x + 3$ is
[A] $4x^2 + x + 1$ [B] $4x^2 - x + 1$
[C] $4x^2 + x - 1$ [D] $4x^2 - x - 1$
595. 080423a, P.I. A.A.13
The expression $(3x^2 + 2xy + 7) - (6x^2 - 4xy + 3)$ is equivalent to
[A] $3x^2 - 6xy - 4$ [B] $-3x^2 + 6xy + 4$
[C] $-3x^2 - 2xy + 4$ [D] $3x^2 - 2xy + 4$
596. 010707a, P.I. A.A.13
The expression $(2x^2 + 6x + 5) - (6x^2 + 3x + 5)$ is equivalent to
[A] $4x^2 + 3x - 10$ [B] $-4x^2 - 3x + 10$
[C] $4x^2 - 3x$ [D] $-4x^2 + 3x$
597. 060511a, P.I. A.A.13
The expression $(x^2 - 5x - 2) - (-6x^2 - 7x - 3)$ is equivalent to
[A] $7x^2 - 2x + 1$ [B] $7x^2 - 12x - 5$
[C] $7x^2 + 2x + 1$ [D] $7x^2 + 2x - 5$
598. 010019a, P.I. A.A.13
When $3a^2 - 2a + 5$ is subtracted from $a^2 + a - 1$, the result is
[A] $-2a^2 + 3a - 6$ [B] $2a^2 - 3a + 6$
[C] $2a^2 - 3a - 6$ [D] $-2a^2 + 3a + 6$
599. 060019a, P.I. A.A.13
If $2x^2 - 4x + 6$ is subtracted from $5x^2 + 8x - 2$, the difference is
[A] $3x^2 + 4x + 4$ [B] $-3x^2 + 4x + 4$
[C] $-3x^2 - 12x + 8$ [D] $3x^2 + 12x - 8$
600. 080020a, P.I. A.A.13
When $3x^2 - 2x + 1$ is subtracted from $2x^2 + 7x + 5$, the result will be
[A] $-x^2 + 5x + 6$ [B] $-x^2 + 9x + 4$
[C] $x^2 + 5x + 6$ [D] $x^2 - 9x - 4$

601. 080209a, P.I. A.A.13
When $-2x^2 + 4x + 2$ is subtracted from $x^2 + 6x - 4$, the result is
- [A] $3x^2 + 2x - 6$ [B] $2x^2 - 2x - 6$
[C] $-x^2 + 10x - 2$ [D] $-3x^2 - 2x + 6$
602. 010429a, P.I. A.A.13
If $2x^2 - x + 6$ is subtracted from $x^2 + 3x - 2$, the result is
- [A] $x^2 - 4x + 8$ [B] $-x^2 + 4x - 8$
[C] $-x^2 + 2x - 8$ [D] $x^2 + 2x - 8$
603. 010523a, P.I. A.A.13
When $3x^2 - 8x$ is subtracted from $2x^2 + 3x$, the difference is
- [A] $x^2 - 5x$ [B] $-x^2 - 11x$
[C] $-x^2 - 5x$ [D] $-x^2 + 11x$
604. 010619a, P.I. A.A.13
When $3a^2 - 7a + 6$ is subtracted from $4a^2 - 3a + 4$, the result is
- [A] $a^2 + 4a - 2$ [B] $-a^2 - 4a + 2$
[C] $a^2 - 10a - 2$ [D] $7a^2 - 10a + 10$
605. 080123a, P.I. A.A.13
Subtract $5x^2 - 7x - 6$ from $9x^2 + 3x - 4$.

CHAPTER 10-2

606. 010819a, P.I. A.A.13
What is the product of $2r^2 - 5$ and $3r$?
- [A] $6r^2 - 15r$ [B] $6r^2 - 15$
[C] $6r^3 - 15r$ [D] $6r^3 - 5$

FACTORING POLYNOMIALS

607. 060506a, P.I. A.A.14
When $3x^2 - 6x$ is divided by $3x$, the result is
- [A] $x - 2$ [B] $x + 2$
[C] $2x$ [D] $-2x$
608. 010724a, P.I. A.A.14
The expression $(50x^3 - 60x^2 + 10x) \div 10x$ is equivalent to
- [A] $5x^3 - 6x^2 + x$ [B] $5x^2 - 60x^2 + 10x$
[C] $5x^2 - 6x$ [D] $5x^2 - 6x + 1$
609. 060421a, P.I. A.A.20
If $3x$ is one factor of $3x^2 - 9x$, what is the other factor?
- [A] $x^2 - 6x$ [B] $x + 3$
[C] $x - 3$ [D] $3x$
610. 060318a, P.I. A.A.20
If one factor of $56x^4y^3 - 42x^2y^6$ is $14x^2y^3$, what is the other factor?
- [A] $4x^2 - 3y^2$ [B] $4x^2y - 3xy^2$
[C] $4x^2 - 3y^3$ [D] $4x^2y - 3xy^3$

CHAPTER 10-3

OPERATIONS WITH POLYNOMIALS

611. 060708a, P.I. A.A.13
What is the product of $(c + 8)$ and $(c - 5)$?
- [A] $c^2 + 3c - 40$ [B] $c^2 + 13c - 40$
[C] $c^2 - 40$ [D] $c^2 - 3c - 40$
612. 010430a, P.I. A.A.13
The expression $(a^2 + b^2)^2$ is equivalent to
- [A] $a^4 + a^2b^2 + b^4$ [B] $a^4 + 2a^2b^2 + b^4$
[C] $a^4 + 4a^2b^2 + b^4$ [D] $a^4 + b^4$

613. 060015a, P.I. A.A.13
The expression $(x - 6)^2$ is equivalent to

[A] $x^2 + 12x + 36$ [B] $x^2 - 36$
[C] $x^2 - 12x + 36$ [D] $x^2 + 36$

CHAPTER 10-4

FACTORING POLYNOMIALS

614. 010004a, P.I. A.A.20
Which expression is a factor of $x^2 + 2x - 15$
- [A] $(x + 3)$ [B] $(x - 3)$
[C] $(x - 5)$ [D] $(x + 15)$
615. 060206a, P.I. A.A.20
Which expression is a factor of $n^2 + 3n - 54$?
- [A] $n - 9$ [B] $n + 6$
[C] $n + 9$ [D] $n^2 + 9$
616. 010814a, P.I. A.A.20
What are the factors of $x^2 - 5x + 6$?
- [A] $(x - 2)$ and $(x - 3)$
[B] $(x + 6)$ and $(x - 1)$
[C] $(x + 2)$ and $(x + 3)$
[D] $(x - 6)$ and $(x + 1)$
617. 010318a, P.I. A.A.20
What are the factors of $x^2 - 10x - 24$?
- [A] $(x - 12)(x + 2)$ [B] $(x + 12)(x - 2)$
[C] $(x - 4)(x - 6)$ [D] $(x - 4)(x + 6)$
618. 060623a, P.I. A.A.20
Factored completely, the expression $2y^2 + 12y - 54$ is equivalent to
- [A] $(y + 6)(2y - 9)$ [B] $2(y - 3)(y - 9)$
[C] $2(y + 9)(y - 3)$ [D] $(2y + 6)(y - 9)$
619. 060535a, P.I. A.A.20
Factor completely: $3x^2 + 15x - 42$

CHAPTER 10-5

620. fall0706ia, P.I. A.A.19
The expression $x^2 - 16$ is equivalent to
- [A] $(x - 2)(x + 8)$ [B] $(x + 2)(x - 8)$
[C] $(x + 8)(x - 8)$ [D] $(x + 4)(x - 4)$
621. 010414a, P.I. A.A.19
What is a common factor of $x^2 - 9$ and $x^2 - 5x + 6$?
- [A] x^2 [B] $x + 3$
[C] $x - 2$ [D] $x - 3$
622. 010201a, P.I. A.A.19
Expressed in factored form, the binomial $4a^2 - 9b^2$ is equivalent to
- [A] $(2a + 3b)(2a - 3b)$
[B] $(4a - 3b)(a + 3b)$
[C] $(2a - 3b)(2a - 3b)$
[D] $(2a - 9b)(2a + b)$
623. 010105a, P.I. A.A.19
One of the factors of $4x^2 - 9$ is
- [A] $(2x + 3)$ [B] $(x + 3)$
[C] $(4x - 3)$ [D] $(x - 3)$
624. 080711a, P.I. A.A.19
One factor of the expression $x^2y^2 - 16$ is
- [A] $x^2 - 4$ [B] $x^2 + 8$
[C] $xy - 4$ [D] $xy - 8$
625. 060109a, P.I. A2.A.7
Factor completely: $3x^2 - 27$
- [A] $3(x^2 - 27)$ [B] $(3x + 3)(x - 9)$
[C] $3(x + 3)(x - 3)$ [D] $3(x - 3)^2$

626. 080103a, P.I. A2.A.7
Written in simplest factored form, the binomial $2x^2 - 50$ can be expressed as
[A] $(x - 5)(x + 5)$ [B] $2x(x - 50)$
[C] $2(x - 5)(x - 5)$ [D] $2(x - 5)(x + 5)$
627. 080533a, P.I. A2.A.7
Factor completely: $5n^2 - 80$
628. 080434a, P.I. A2.A.7
Factor completely: $3ax^2 - 27a$
634. 080118a, P.I. A.A.27
What is the solution set of $m^2 - 3m - 10 = 0$?
[A] {3,10} [B] {3,-10}
[C] {5,-2} [D] {2,-5}
635. 060313a, P.I. A.A.27
What is the solution set of the equation $x^2 - 5x - 24 = 0$?
[A] {-3,-8} [B] {3,-8}
[C] {3,8} [D] {-3,8}

CHAPTER 10-6

SOLVING QUADRATICS

629. 069909a, P.I. A.A.28
The larger root of the equation $(x + 4)(x - 3) = 0$ is
[A] 3 [B] -3 [C] 4 [D] -4
630. 080622a, P.I. A.A.27
One of the roots of the equation $x^2 + 3x - 18 = 0$ is 3. What is the other root?
[A] -6 [B] 15 [C] -21 [D] 6
631. 010727a, P.I. A.A.27
What is the solution set of the equation $x^2 - 5x = 0$?
[A] {0,5} [B] {0,-5} [C] {5} [D] {0}
632. 080012a, P.I. A.A.27
The solution set for the equation $x^2 - 2x - 15 = 0$ is
[A] {-5,-3} [B] {5,3}
[C] {-5,3} [D] {5,-3}
633. 060725a, P.I. A.A.27
The solution set of the equation $x^2 - 4x - 12 = 0$ is
[A] {-2,6} [B] {-6,2}
[C] {-4,3} [D] {-3,4}
636. 010520a, P.I. A.A.27
What is the solution set for the equation $x^2 - 5x + 6 = 0$?
[A] {-6,1} [B] {2,3}
[C] {-2,-3} [D] {6,-1}
637. 060514a, P.I. A.A.27
What is the solution set of the equation $x^2 + 11x + 28 = 0$?
[A] {-3,-4} [B] {-7,4}
[C] {-7,-4} [D] {3,4}
638. 089926a, P.I. A.A.27
Solve for x : $x^2 + 3x - 40 = 0$
639. 060229a, P.I. A.A.27
Solve for x : $x^2 + 3x - 28 = 0$
640. 010637a, P.I. A.A.27
Solve for x : $x^2 + 2x - 24 = 0$
641. 080525a, P.I. A.A.27
The solution set for the equation $x^2 - 5x = 6$ is
[A] {-2,3} [B] {2,-3}
[C] {1,-6} [D] {-1,6}

642. 060430a, P.I. A.A.28
If $(x - 4)$ is a factor of $x^2 - x - w = 0$, then the value of w is

[A] -12 [B] 12 [C] 3 [D] -3

643. 060606b, P.I. A.A.8
If the equation $x^2 - kx - 36 = 0$ has $x = 12$ as one root, what is the value of k ?

[A] -3 [B] 3 [C] 9 [D] -9

WRITING QUADRATICS

644. 080627a, P.I. A.A.8
When Albert flips open his mathematics textbook, he notices that the product of the page numbers of the two facing pages that he sees is 156. Which equation could be used to find the page numbers that Albert is looking at?

[A] $(x + 1)(x + 3) = 156$
[B] $x + (x + 1) = 156$ [C] $x(x + 1) = 156$
[D] $(x + 1) + (x + 2) = 156$

645. 060608a
What is the length of one side of the square whose perimeter has the same numerical value as its area?

[A] 4 [B] 3 [C] 5 [D] 6

646. 060425a, P.I. A.A.5
A farmer has a rectangular field that measures 100 feet by 150 feet. He plans to increase the area of the field by 20%. He will do this by increasing the length and width by the same amount, x . Which equation represents the area of the new field?

[A] $(100 + 2x)(150 + x) = 18,000$
[B] $(100 + x)(150 + x) = 18,000$
[C] $(100 + x)(150 + x) = 15,000$
[D] $2(100 + x) + 2(150 + x) = 15,000$

647. fall0726ia, P.I. A.A.8
The length of a rectangular window is 5 feet more than its width, w . The area of the window is 36 square feet. Which equation could be used to find the dimensions of the window?

[A] $w^2 - 5w - 36 = 0$ [B] $w^2 + 5w + 36 = 0$
[C] $w^2 - 5w + 36 = 0$ [D] $w^2 + 5w - 36 = 0$

648. 080035a, P.I. A.A.8
Jack is building a rectangular dog pen that he wishes to enclose. The width of the pen is 2 yards less than the length. If the area of the dog pen is 15 square yards, how many yards of fencing would he need to completely enclose the pen?

649. 060035a, P.I. A.A.8
The area of the rectangular playground enclosure at South School is 500 square meters. The length of the playground is 5 meters longer than the width. Find the dimensions of the playground, in meters. *[Only an algebraic solution will be accepted.]*

650. 010233a, P.I. A.A.8
Javon's homework is to determine the dimensions of his rectangular backyard. He knows that the length is 10 feet more than the width, and the total area is 144 square feet. Write an equation that Javon could use to solve this problem. Then find the dimensions, in feet, of his backyard.

651. 080232a, P.I. A.A.8
A rectangular park is three blocks longer than it is wide. The area of the park is 40 square blocks. If w represents the width, write an equation in terms of w for the area of the park. Find the length and the width of the park.

652. 080431b, P.I. A.A.8
A rectangular piece of cardboard is to be formed into an uncovered box. The piece of cardboard is 2 centimeters longer than it is wide. A square that measures 3 centimeters on a side is cut from each corner. When the sides are turned up to form the box, its volume is 765 cubic centimeters. Find the dimensions, in centimeters, of the original piece of cardboard.
653. 010326a, P.I. A.A.8
Three brothers have ages that are consecutive even integers. The product of the first and third boys' ages is 20 more than twice the second boy's age. Find the age of *each* of the three boys.
654. 060131a, P.I. A.A.8
Find three consecutive odd integers such that the product of the first and the second exceeds the third by 8.
655. 060636a, P.I. A.A.8
Tamara has two sisters. One of the sisters is 7 years older than Tamara. The other sister is 3 years younger than Tamara. The product of Tamara's sisters' ages is 24. How old is Tamara?
656. 010830b, P.I. A2.A.21
Write a quadratic equation such that the sum of its roots is -5 and the product of its roots is 6. What are the roots of this equation?

658. 010822a, P.I. A.A.15
For which value of x is the expression $\frac{6-x}{x+2}$ undefined?
[A] 6 [B] -2 [C] 2 [D] 0
659. 060319a, P.I. A.A.15
For which value of x is the expression $\frac{3x-6}{x-4}$ undefined?
[A] -4 [B] 2 [C] 0 [D] 4
660. 080610a, P.I. A.A.15
For which value of x is the expression $\frac{3}{x-2}$ undefined?
[A] 3 [B] -2 [C] 2 [D] 0
661. 010607a, P.I. A.A.15
For which value of x will the fraction $\frac{3}{2x+4}$ be undefined?
[A] -2 [B] -4 [C] 2 [D] 0
662. fall0728ia, P.I. A.A.15
For which value of x is $\frac{x-3}{x^2-4}$ undefined?
[A] 0 [B] 4 [C] 3 [D] -2
663. 010716a, P.I. A.A.15
Which expression is undefined when $w = 3$?
[A] $\frac{w-3}{w+1}$ [B] $\frac{w+1}{w^2-3w}$
[C] $\frac{w^2+2w}{5w}$ [D] $\frac{3w}{3w^2}$
664. 010109a, P.I. A.A.14
If $x \neq 0$, the expression $\frac{x^2+2x}{x}$ is equivalent to
[A] 4 [B] $3x$ [C] 2 [D] $x+2$

CHAPTER 11-3

RATIONAL EXPRESSIONS

657. 080422a, P.I. A.A.15
For which value of x is the expression $\frac{x-7}{x+2}$ undefined?
[A] 2 [B] -2 [C] 0 [D] 7

676. 069906a, P.I. A.A.16
Expressed as a single fraction, what is

$$\frac{1}{x+1} + \frac{1}{x}, x \neq 0, -1?$$

- [A] $\frac{3}{x^2}$ [B] $\frac{2x+1}{x^2+x}$
[C] $\frac{2}{2x+1}$ [D] $\frac{2x+3}{x^2+x}$

CHAPTER 11-5

SOLVING RATIONALS

677. 060612a, P.I. A.A.26
What is the value of x in the equation
 $\frac{x}{2x+1} = \frac{4}{3}$?
- [A] $-\frac{1}{5}$ [B] $-\frac{5}{4}$ [C] $-\frac{4}{5}$ [D] -5

678. 010131a, P.I. A.A.26
Solve algebraically for x : $\frac{1}{x} = \frac{x+1}{6}$

679. 080439a, P.I. A.A.26
Solve for all values of x that satisfy the equation $\frac{x}{x+3} = \frac{5}{x+7}$.

680. fall0739ia, P.I. A.A.26
Solve for x : $\frac{x+1}{x} = \frac{-7}{x-12}$

681. 010825a, P.I. A.A.26
If $\frac{5}{n} - \frac{1}{2} = \frac{3}{6n}$, what is the value of n ?
- [A] 9 [B] -2 [C] 2 [D] $\frac{2}{7}$

CHAPTER 11-6

MULTIPLICATION COUNTING PRINCIPLE

682. 060728a, P.I. A2.S.9
Max goes through the cafeteria line and counts seven different meals and three different desserts that he can choose. Which expression can be used to determine how many different ways Max can choose a meal and a dessert?
- [A] ${}_7C_3$ [B] ${}_7P_3$
[C] $7 \cdot 3$ [D] $7! \cdot 3!$
683. 010612a, P.I. A2.S.9
Robin has 8 blouses, 6 skirts, and 5 scarves. Which expression can be used to calculate the number of different outfits she can choose, if an outfit consists of a blouse, a skirt, and a scarf?
- [A] $8+6+5$ [B] $8 \cdot 6 \cdot 5$
[C] ${}_{19}C_3$ [D] $8!6!5!$
684. 060607a, P.I. A2.S.9
Leo purchased five shirts, three pairs of pants, and four pairs of shoes. Which expression represents how many different outfits consisting of one shirt, one pair of pants, and one pair of shoes Leo can make?
- [A] ${}_{12}C_3$ [B] $5+3+4$
[C] ${}_{12}P_3$ [D] $5 \cdot 3 \cdot 4$
685. 080704a, P.I. A2.S.9
Jen and Barry's ice cream stand has three types of cones, six flavors of ice cream, and four kinds of sprinkles. If a serving consists of a cone, one flavor of ice cream, and one kind of sprinkles, how many different servings are possible?
- [A] 72 [B] 90 [C] ${}_{13}C_3$ [D] ${}_{13}P_3$

686. 060403a, P.I. A.N.7
How many different outfits consisting of a hat, a pair of slacks, and a sweater can be made from two hats, three pairs of slacks, and four sweaters?
[A] 29 [B] 24 [C] 12 [D] 9
687. 080204a, P.I. A.N.7
Juan has three blue shirts, two green shirts, seven red shirts, five pairs of denim pants, and two pairs of khaki pants. How many different outfits consisting of one shirt and one pair of pants are possible?
[A] 420 [B] 84 [C] 19 [D] 130
688. 089923a, P.I. A.N.7
Paloma has 3 jackets, 6 scarves, and 4 hats. Determine the number of different outfits consisting of a jacket, a scarf, and a hat that Paloma can wear.
689. 080404a, P.I. A.N.7
The school cafeteria offers five sandwich choices, four desserts, and three beverages. How many different meals consisting of one sandwich, one dessert, and one beverage can be ordered?
[A] 3 [B] 12 [C] 1 [D] 60
690. 010503a, P.I. A.N.7
A deli has five types of meat, two types of cheese, and three types of bread. How many different sandwiches, consisting of one type of meat, one type of cheese, and one type of bread, does the deli serve?
[A] 10 [B] 25 [C] 75 [D] 30
691. 080502a, P.I. A.N.7
Cole's Ice Cream Stand serves sixteen different flavors of ice cream, three types of syrup, and seven types of sprinkles. If an ice cream sundae consists of one flavor of ice cream, one type of syrup, and one type of sprinkles, how many different ice cream sundaes can Cole serve?
[A] 336 [B] 3 [C] 10,836 [D] 26
692. 010405a, P.I. A.N.7
In a school building, there are 10 doors that can be used to enter the building and 8 stairways to the second floor. How many different routes are there from outside the building to a class on the second floor?
[A] 80 [B] 18 [C] 10 [D] 1
693. 060501a, P.I. A.N.7
Jeremy's bedroom has two doors leading into the hallway. His house has four doors leading to the outside. Using the doorways, in how many different ways can Jeremy leave his room and go outside?
[A] 6 [B] 8 [C] 4 [D] 5
694. 080111a, P.I. A.N.7
A certain car comes in three body styles with a choice of two engines, a choice of two transmissions, and a choice of six colors. What is the minimum number of cars a dealer must stock to have one car of every possible combination?
[A] 42 [B] 72 [C] 36 [D] 13
695. 080636a, P.I. A.N.7
Debbie goes to a diner famous for its express lunch menu. The menu has five appetizers, three soups, seven entrees, six vegetables, and four desserts. How many different meals consisting of either an appetizer *or* a soup, one entree, one vegetable, and one dessert can Debbie order?

696. 010218a
When Kimberly bought her new car, she found that there were 72 different ways her car could be equipped. Her choices included four choices of engine and three choices of transmission. If her only other choice was color, how many choices of color did she have?
[A] 6 [B] 12 [C] 60 [D] 65

PERMUTATIONS

697. 080107a, P.I. A.N.6
The value of $5!$ is
[A] 5 [B] $\frac{1}{5}$ [C] 120 [D] 20
698. 080503a, P.I. A.N.6
The value of $\frac{7!}{3!}$ is
[A] 840 [B] 24 [C] 4 [D] 7
699. 060605a, P.I. A.N.6
What is the value of $\frac{8!}{4!}$?
[A] $4!$ [B] 2 [C] $2!$ [D] 1,680
700. 010713a, A2.S.10
Which value is equivalent to ${}_3P_3$?
[A] $3!$ [B] 9 [C] 27 [D] 1
701. 089917a, P.I. A.N.8
How many different 6-letter arrangements can be formed using the letters in the word "ABSENT," if each letter is used only once?
[A] 720 [B] 6 [C] 46,656 [D] 36
702. 010013a, P.I. A.N.8
How many different 4-letter arrangements can be formed using the letters of the word "JUMP," if each letter is used only once?
[A] 4 [B] 16 [C] 12 [D] 24

703. 060723a, P.I. A.N.8
What is the total number of different four-letter arrangements that can be formed from the letters in the word "VERTICAL," if each letter is used only once in an arrangement?
[A] 1,680 [B] 8
[C] 6,720 [D] 40,320
704. 010829a, P.I. A2.S.10
What is the total number of different seven-letter arrangements that can be formed using the letters in the word "MILLION"?
[A] 30 [B] 1,260 [C] 210 [D] 2,520
705. 080727a, P.I. A2.S.10
Which expression represents the number of different 8-letter arrangements that can be made from the letters of the word "SAVANNAH" if each letter is used only once?
[A] $8!$ [B] ${}_8P_5$ [C] $\frac{8!}{3!2!}$ [D] $\frac{8!}{5!}$
706. 010114a, P.I. A.N.8
A locker combination system uses three digits from 0 to 9. How many different three-digit combinations with no digit repeated are possible?
[A] 504 [B] 1,000 [C] 30 [D] 720
707. 060016a, P.I. A.N.8
How many different five-digit numbers can be formed from the digits 1, 2, 3, 4, and 5 if each digit is used only once?
[A] 120 [B] 60 [C] 20 [D] 24
708. 060023a, P.I. A.N.8
All seven-digit telephone numbers in a town begin with 245. How many telephone numbers may be assigned in the town if the last four digits do *not* begin or end in a zero?

709. 080616a, P.I. A.N.8
Julia has four different flags that she wants to hang on the wall of her room. How many different ways can the flags be arranged in a row?

[A] 16 [B] 1 [C] 10 [D] 24

710. 010323a, P.I. A.N.8
Six members of a school's varsity tennis team will march in a parade. How many different ways can the players be lined up if Angela, the team captain, is always at the front of the line?

711. 060125a, P.I. A.N.8
There were seven students running in a race. How many different arrangements of first, second, and third place are possible?

712. 080034a, P.I. A.N.8
The telephone company has run out of seven-digit telephone numbers for an area code. To fix this problem, the telephone company will introduce a new area code. Find the number of new seven-digit telephone numbers that will be generated for the new area code if both of the following conditions must be met:
- o The first digit cannot be a zero or a one.
 - o The first three digits cannot be the emergency number (911) or the number used for information (411).

713. 010435a, P.I. A.N.8
In Jackson County, Wyoming, license plates are made with two letters (A through Z) followed by three digits (0 through 9). The plates are made according to the following restrictions:
- o the first letter must be *J* or *W*, and the second letter can be any of the 26 letters in the alphabet
 - o no digit can be repeated
- How many different license plates can be made with these restrictions?

714. 060329a, P.I. A.N.8
A certain state is considering changing the arrangement of letters and numbers on its license plates. The two options the state is considering are:
- Option 1: three letters followed by a four-digit number with repetition of both letters and digits allowed
- Option 2: four letters followed by a three-digit number without repetition of either letters or digits
- [Zero may be chosen as the first digit of the number in either option.]
- Which option will enable the state to issue more license plates? How many *more* different license plates will that option yield?

CHAPTER 11-7

COMBINATIONS

715. 080527a, P.I. A2.S.11
The expression ${}_9C_2$ is equivalent to
- [A] ${}_9P_7$ [B] ${}_9P_2$ [C] ${}_9C_7$ [D] $\frac{9!}{2!}$
716. 080720a, P.I. A2.S.11
The expression ${}_8C_3$ is equivalent to
- [A] $\frac{8!}{3!}$ [B] ${}_8P_5$ [C] ${}_8P_3$ [D] ${}_8C_5$
717. 010307a, P.I. A2.S.9
There are 12 people on a basketball team, and the coach needs to choose 5 to put into a game. How many different possible ways can the coach choose a team of 5 if each person has an equal chance of being selected?
- [A] ${}_5P_{12}$ [B] ${}_{12}P_5$ [C] ${}_5C_{12}$ [D] ${}_{12}C_5$

718. 060426a, P.I. A2.S.11
In a game, each player receives 5 cards from a deck of 52 different cards. How many different groupings of cards are possible in this game?
[A] ${}_{52}C_5$ [B] ${}_{52}P_5$ [C] $\frac{52!}{5!}$ [D] $5!$
719. 010515a, P.I. A2.S.11
How many different three-member teams can be selected from a group of seven students?
[A] 5,040 [B] 210 [C] 1 [D] 35
720. 010729a, P.I. A2.S.11
If the Math Olympiad Club consists of eighteen students, how many different teams of four students can be formed for competitions?
[A] 66 [B] 3,060 [C] 73,440 [D] 72
721. 069907a, P.I. A2.S.11
How many different three-member teams can be formed from six students?
[A] 720 [B] 120 [C] 20 [D] 216
722. 060320a, P.I. A2.S.11
How many different five-member teams can be made from a group of eight students, if each student has an equal chance of being chosen?
[A] 56 [B] 6,720 [C] 40 [D] 336
723. 080626a, P.I. A2.S.11
In the next Olympics, the United States can enter four athletes in the diving competition. How many different teams of four divers can be selected from a group of nine divers?
[A] 36 [B] 6,561 [C] 3,024 [D] 126
724. 080025a, P.I. A2.S.11
Alan, Becky, Jesus, and Mariah are four students in the chess club. If two of these students will be selected to represent the school at a national convention, how many combinations of two students are possible?
725. 010424a, P.I. A2.S.11
Five people have volunteered to work on an awards dinner at Madison High School. How many different committees of four can be formed from the five people?
[A] 5 [B] 10 [C] 20 [D] 1
726. 060534a, P.I. A2.S.11
An algebra class of 21 students must send 5 students to meet with the principal. How many different groups of 5 students could be formed from this class?
727. 060114a, P.I. A2.S.11
If there are four teams in a league, how many games will have to be played so that each team plays every other team once?
[A] 8 [B] 6 [C] 3 [D] 16
728. 060632a, P.I. A2.S.11
Five friends met for lunch, and they all shook hands. Each person shook the other person's right hand only once. What was the total number of handshakes?
729. 080126a, P.I. A2.S.11
Megan decides to go out to eat. The menu at the restaurant has four appetizers, three soups, seven entrees, and five desserts. If Megan decides to order an appetizer or a soup, and one entree, and two different desserts, how many different choices can she make?

730. 010628a, P.I. A2.S.9
A committee of five members is to be randomly selected from a group of nine freshmen and seven sophomores. Which expression represents the number of different committees of three freshmen and two sophomores that can be chosen?
- [A] ${}_{16}C_3 \cdot {}_{16}C_2$ [B] ${}_9C_3 \cdot {}_7C_2$
[C] ${}_9P_3 \cdot {}_7P_2$ [D] ${}_9C_3 + {}_7C_2$
731. 080229a, P.I. A2.S.11
On a bookshelf, there are five different mystery books and six different biographies. How many different sets of four books can Emilio choose if two of the books must be mystery books and two of the books must be biographies?
732. 010034a, P.I. A2.S.12
Three roses will be selected for a flower vase. The florist has 1 red rose, 1 white rose, 1 yellow rose, 1 orange rose and 1 pink rose from which to choose.
- a* How many different three rose selections can be formed from the 5 roses?
b What is the probability that 3 roses selected at random will contain 1 red rose, 1 white rose, and 1 pink rose?
c What is the probability that 3 roses selected at random will *not* contain an orange rose?
733. 060034a, P.I. A2.S.12
Paul orders a pizza. Chef Carl randomly chooses two different toppings to put on the pizza from the following: pepperoni, onion, sausage, mushrooms, and anchovies. If Paul will not eat pizza with mushrooms, determine the probability that Paul will *not* eat the pizza Chef Carl has made.
734. 010126a, P.I. A2.S.12
Sal has a small bag of candy containing three green candies and two red candies. While waiting for the bus, he ate two candies out of the bag, one after another, without looking. What is the probability that both candies were the same color?
735. 060234a, P.I. A2.S.12
Alexi's wallet contains four \$1 bills, three \$5 bills, and one \$10 bill. If Alexi randomly removes two bills without replacement, determine whether the probability that the bills will total \$15 is greater than the probability that the bills will total \$2.
736. 069932a, P.I. A2.S.12
A bookshelf contains six mysteries and three biographies. Two books are selected at random without replacement.
- a* What is the probability that both books are mysteries?
b What is the probability that one book is a mystery and the other is a biography?