

# JEFFERSON MATH PROJECT REGENTS BY CHAPTER

535 NY Regents Exam Questions from  
June 1999 to January 2008 Sorted by Prentice Hall Chapter  
ADVANCED ALGEBRA

[www.jmap.org](http://www.jmap.org)



Dear Sir

I have to acknowledge the receipt of your favor of May 14. in which you mention that you have finished the 6. first books of Euclid, plane trigonometry, surveying & algebra and ask whether I think a further pursuit of that branch of science would be useful to you. there are some propositions in the latter books of Euclid, & some of Archimedes, which are useful, & I have no doubt you have been made acquainted with them. trigonometry, so far as this, is most valuable to every man, there is scarcely a day in which he will not resort to it for some of the purposes of common life. the science of calculation also is indispensable as far as the extraction of the square & cube roots; Algebra as far as the quadratic equation & the use of logarithms are often of value in ordinary cases: but all beyond these is but a luxury; a delicious luxury indeed; but not to be indulged in by one who is to have a profession to follow for his subsistence. in this light I view the conic sections, curves of the higher orders, perhaps even spherical trigonometry, Algebraical operations beyond the 2d dimension, and fluxions.

Letter from Thomas Jefferson to William G. Munford, Monticello, June 18, 1799.

# TABLE OF CONTENTS

## ADVANCED ALGEBRA

	<u>PRENTICE HALL CHAPTER</u>	<u>QUESTION NUMBER</u>
CH1	Patterns, Models, and Functions	1-63
CH2	Linear Relationships and Functions	64-82
CH5	Quadratic Equations and Functions	83-180
CH6	Polynomials and Polynomial Functions	181-227
CH7	Exponential and Logarithmic Functions	228-283
CH8	Rational Functions	284-345
CH9	Periodic Functions and Trigonometry	346-478
CH10	Quadratic Relations	479-488
CH11	More Probability and Statistics	489-520
CH12	Sequences and Series	521-535

# CHAPTER 1-3

## DEFINING FUNCTIONS

1. fall0730ia, P.I. A.G.3

Which graph represents a function?

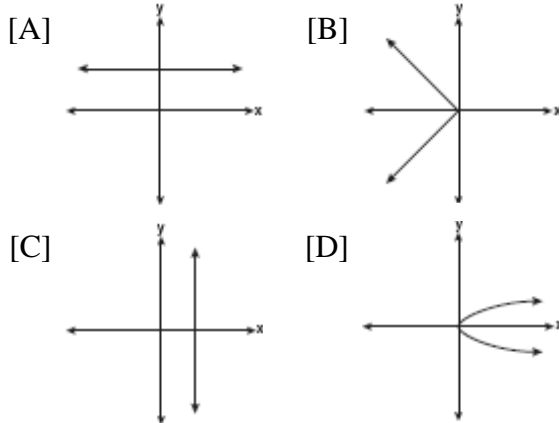

2. 010511b, P.I. A.G.3

Which graph is *not* a function?

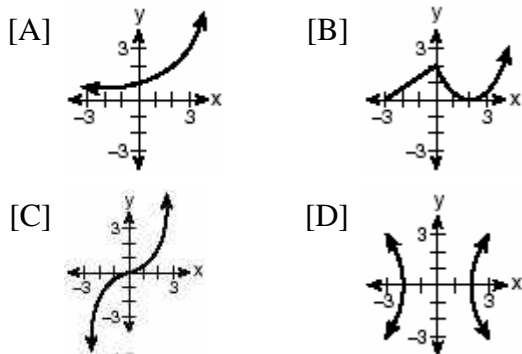

3. 080301b, P.I. A.G.3

Which graph does not represent a function of  $x$ ?

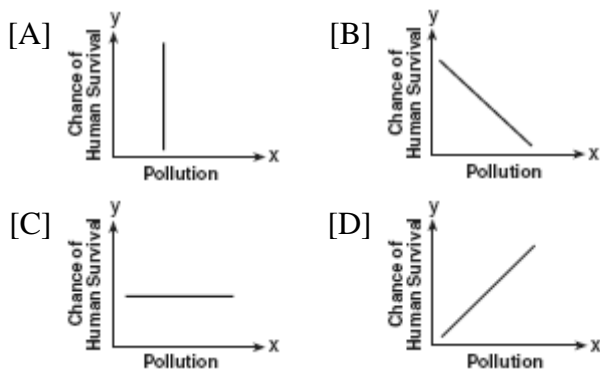

4. 060601b, P.I. A.G.3

Each graph below represents a possible relationship between temperature and pressure. Which graph does *not* represent a function?

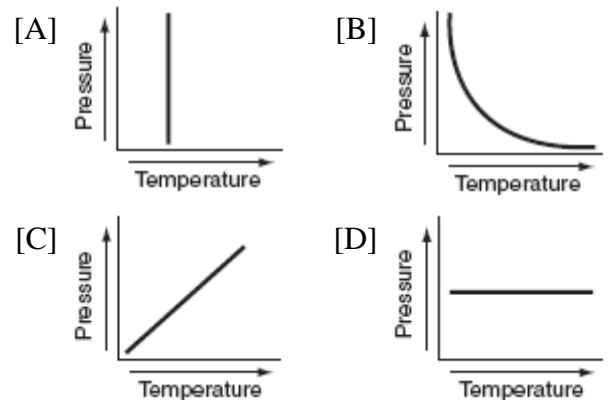

5. 080403b, P.I. A.G.3

Which set of ordered pairs is *not* a function?

- [A]  $\{(1,2), (3,4), (4,5), (5,6)\}$
- [B]  $\{(3,1), (2,1), (1,2), (3,2)\}$
- [C]  $\{(4,1), (5,1), (6,1), (7,1)\}$
- [D]  $\{(0,0), (1,1), (2,2), (3,3)\}$

6. 060715b, P.I. A.G.3

Which set of ordered pairs does *not* represent a function?

- [A]  $\{(3,-2), (4,-3), (5,-4), (6,-5)\}$
- [B]  $\{(3,-2), (3,-4), (4,-1), (4,-3)\}$
- [C]  $\{(3,-2), (5,-2), (4,-2), (-1,-2)\}$
- [D]  $\{(3,-2), (-2,3), (4,-1), (-1,4)\}$

7. 080101b, P.I. A2.A.38

Which relation is *not* a function?

- [A]  $y = x^2 - 4x + 3$
- [B]  $y = 2x + 4$
- [C]  $x = y^2 + 2x - 3$
- [D]  $x = 3y - 2$

8. 080605b, P.I. A2.A.38

Which equation does *not* represent a function?

- [A]  $x = \pi$                       [B]  $y = 4$   
[C]  $y = |x|$                       [D]  $y = x^2 + 5x$

9. 010622b, P.I. A2.A.37

On the accompanying diagram, draw a mapping of a relation from set  $A$  to set  $B$  that is *not* a function. Explain why the relationship you drew is *not* a function.

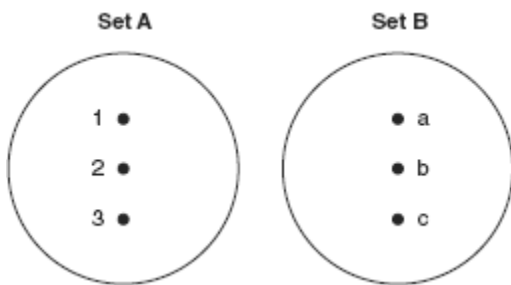

10. 010211b, P.I. A2.A.38

Which relation is a function?

- [A]  $x = y^2 + 1$                       [B]  $x = 4$   
[C]  $y = \sin x$                       [D]  $x^2 + y^2 = 16$

11. 060213b, P.I. A2.A.38

Which equation represents a function?

- [A]  $4y^2 = 36 - 9x^2$                       [B]  $y = x^2 - 3x - 4$   
[C]  $x^2 + y^2 = 4$                       [D]  $x = y^2 - 6x + 8$

12. 060511b, P.I. A2.A.38

Which relation is a function?

- [A]  $x^2 + y^2 = 7$                       [B]  $x^2 - y^2 = 7$   
[C]  $x = 7$                       [D]  $xy = 7$

13. 060310b, P.I. A.G.3

Which diagram represents a relation in which each member of the domain corresponds to only one member of its range?

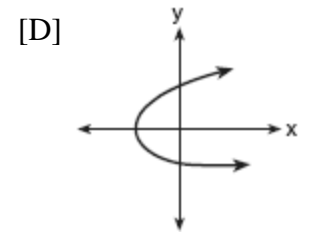
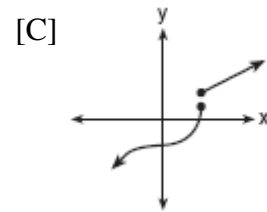
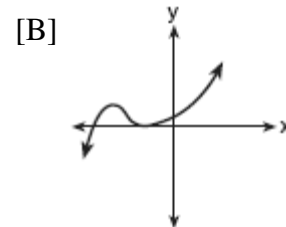
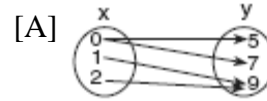

14. 060216b, P.I. A2.A.43

Which diagram represents a one-to-one function?

[A]

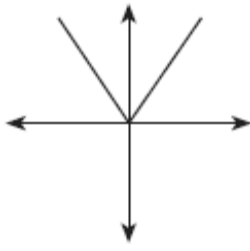

[B]

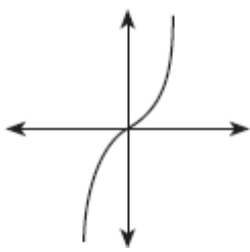

[C]

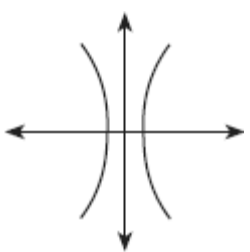

[D]

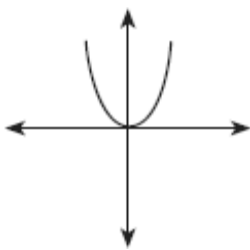

**DOMAIN AND RANGE**

15. 060501b, P.I. A2.A.51

The accompanying graph shows the heart rate, in beats per minute, of a jogger during a 4-minute interval.

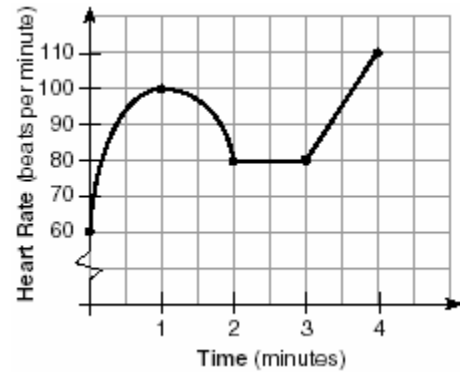

What is the range of the jogger's heart rate during this interval?

- [A] 1-4                      [B] 60-110  
[C] 0-110                  [D] 0-4

16. 010712b, P.I. A2.A.51

Data collected during an experiment are shown in the accompanying graph.

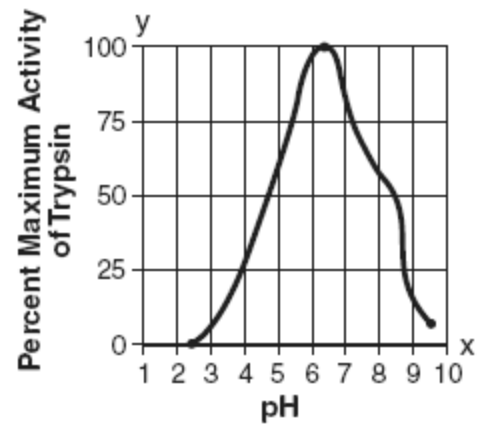

What is the range of this set of data?

- [A]  $1 \leq x \leq 10$               [B]  $0 \leq y \leq 100$   
[C]  $2.5 \leq x \leq 9.5$             [D]  $2.5 \leq y \leq 9.5$

17. 080708b, P.I. A2.A.51

A meteorologist drew the accompanying graph to show the changes in relative humidity during a 24-hour period in New York City.

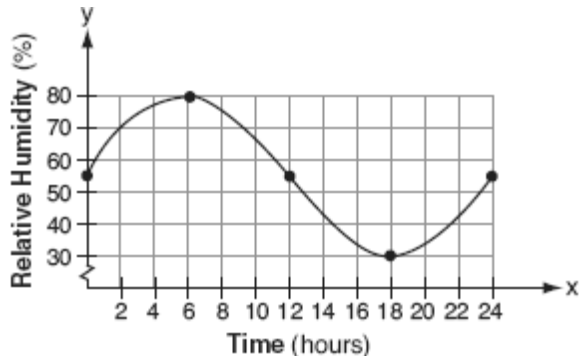

What is the range of this set of data?

- [A]  $30 \leq x \leq 80$       [B]  $0 \leq y \leq 24$   
[C]  $0 \leq x \leq 24$       [D]  $30 \leq y \leq 80$

18. 010602b, P.I. A2.A.51

The effect of pH on the action of a certain enzyme is shown on the accompanying graph.

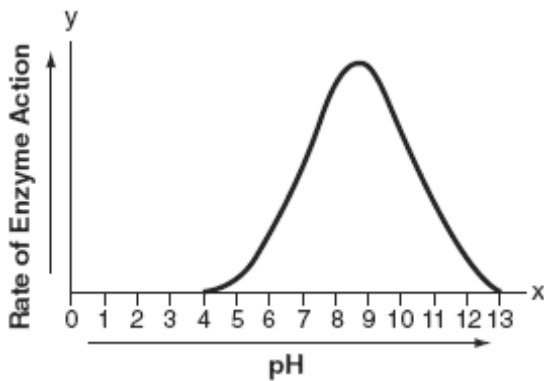

What is the domain of this function?

- [A]  $4 \leq x \leq 13$       [B]  $x \geq 0$   
[C]  $y \geq 0$       [D]  $4 \leq y \leq 13$

19. 080204b, P.I. A2.A.39

What is the domain of  $f(x) = 2^x$ ?

- [A] all real numbers      [B]  $x \geq 0$   
[C] all integers      [D]  $x \leq 0$

20. 010218b, P.I. A2.A.39

What is the domain of  $h(x) = \sqrt{x^2 - 4x - 5}$ ?

- [A]  $\{x | x \geq 1 \text{ or } x \leq -5\}$   
[B]  $\{x | -5 \leq x \leq 1\}$       [C]  $\{x | -1 \leq x \leq 5\}$   
[D]  $\{x | x \geq 5 \text{ or } x \leq -1\}$

21. 060407b, P.I. A2.A.39

What is the domain of the function

$$f(x) = \frac{2x^2}{x^2 - 9}$$

- [A] all real numbers except 3  
[B] all real numbers except 0  
[C] all real numbers  
[D] all real numbers except 3 and -3

22. 010504b, P.I. A2.A.39

What is the domain of the function

$$f(x) = \frac{3x^2}{x^2 - 49}$$

- [A]  $\{x | x \in \text{real numbers, } x \neq 7\}$   
[B]  $\{x | x \in \text{real numbers, } x \neq \pm 7\}$   
[C]  $\{x | x \in \text{real numbers}\}$   
[D]  $\{x | x \in \text{real numbers, } x \neq 0\}$

23. 010314b, P.I. A2.A.39

If  $f(x) = \frac{1}{\sqrt{2x-4}}$ , the domain of  $f(x)$  is

- [A]  $x \geq 2$       [B]  $x < 2$   
[C]  $x > 2$       [D]  $x = 2$

### **FUNCTIONAL NOTATION**

24. 060406b, P.I. A2.A.41

If  $f(x) = 4x^0 + (4x)^{-1}$ , what is the value of  $f(4)$ ?

- [A]  $1\frac{1}{16}$       [B] -12      [C]  $4\frac{1}{16}$       [D] 0

25. 080701b, P.I. A2.A.41  
If  $f(x) = (x^{-x} - x^0 + 2^x)$ , then  $f(3)$  is equal to
- [A]  $7\frac{1}{27}$  [B]  $-22$   
[C]  $8\frac{1}{27}$  [D]  $-21$
26. 010220b, P.I. A.A.6  
The revenue,  $R(x)$ , from selling  $x$  units of a product is represented by the equation  $R(x) = 35x$ , while the total cost,  $C(x)$ , of making  $x$  units of the product is represented by the equation  $C(x) = 20x + 500$ . The total profit,  $P(x)$ , is represented by the equation  $P(x) = R(x) - C(x)$ . For the values of  $R(x)$  and  $C(x)$  given above, what is  $P(x)$ ?
- [A]  $15x + 500$  [B]  $10x + 100$   
[C]  $15x$  [D]  $15x - 500$
27. 080332b, P.I. A.A.6  
A company calculates its profit by finding the difference between revenue and cost. The cost function of producing  $x$  hammers is  $C(x) = 4x + 170$ . If each hammer is sold for \$10, the revenue function for selling  $x$  hammers is  $R(x) = 10x$ . How many hammers must be sold to make a profit? How many hammers must be sold to make a profit of \$100?
30. 060322b, P.I. A2.A.42  
If  $f(x) = 2^x - 1$  and  $g(x) = x^2 - 1$ , determine the value of  $(f \circ g)(3)$ .
31. 010207b, P.I. A2.A.42  
If  $f(x) = 5x^2$  and  $g(x) = \sqrt{2x}$ , what is the value of  $(f \circ g)(8)$ ?
- [A] 16 [B] 1,280 [C] 80 [D]  $8\sqrt{10}$
32. 060725b, P.I. A2.A.42  
If  $f(x) = \log_2 x$  and  $g(x) = 2x^2 + 14$ , determine the value of  $(f \circ g)(5)$ .
33. 010331b, P.I. A2.A.42  
If  $f(x) = x^{\frac{2}{3}}$  and  $g(x) = 8x^{\frac{1}{2}}$ , find  $(f \circ g)(x)$  and  $(f \circ g)(27)$ .
34. 080313b, P.I. A2.A.42  
If  $f$  and  $g$  are two functions defined by  $f(x) = 3x + 5$  and  $g(x) = x^2 + 1$ , then  $g(f(x))$  is
- [A]  $3x^2 + 8$  [B]  $9x^2 + 26$   
[C]  $x^2 + 3x + 6$  [D]  $9x^2 + 30x + 26$
35. 010408b, P.I. A2.A.42  
If  $f(x) = \frac{2}{x+3}$  and  $g(x) = \frac{1}{x}$ , then  $(g \circ f)(x)$  is equal to
- [A]  $\frac{1+3x}{2x}$  [B]  $\frac{2x}{1+3x}$   
[C]  $\frac{x+3}{2x}$  [D]  $\frac{x+3}{2}$
36. 060417b, P.I. A2.A.42  
If  $f(x) = x + 1$  and  $g(x) = x^2 - 1$ , the expression  $(g \circ f)(x)$  equals 0 when  $x$  is equal to
- [A] 0 and -2 [B] -2, only  
[C] 0, only [D] 1 and -1

## CHAPTER 1-4

### COMPOSITIONS OF FUNCTIONS

28. 010501b, P.I. A2.A.42  
If  $f(x) = -2x + 7$  and  $g(x) = x^2 - 2$ , then  $f(g(3))$  is equal to
- [A] -7 [B] -3 [C] -1 [D] 7
29. 010621b, P.I. A2.A.42  
If  $f(x) = 5x^2 - 1$  and  $g(x) = 3x - 1$ , find  $g(f(1))$ .

37. 060210b, P.I. A2.A.42

If  $f(x) = 2x^2 + 4$  and  $g(x) = x - 3$ , which number satisfies  $f(x) = (f \circ g)(x)$ ?

- [A]  $\frac{3}{4}$     [B] 5    [C] 4    [D]  $\frac{3}{2}$

38. 010812b, P.I. A2.A.42

The accompanying tables define functions  $f$  and  $g$ .

$x$	1	2	3	4	5
$f(x)$	3	4	5	6	7

$x$	3	4	5	6	7
$g(x)$	4	6	8	10	12

What is  $(g \circ f)(3)$ ?

- [A] 8    [B] 6    [C] 4    [D] 2

39. 080520b, P.I. A2.A.42

The accompanying graph is a sketch of the function  $y = f(x)$  over the interval  $0 \leq x \leq 7$ .

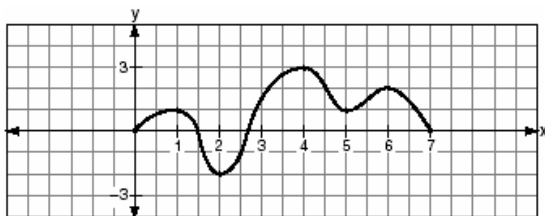

What is the value of  $(f \circ f)(6)$ ?

- [A] 0    [B] 1    [C] 2    [D] -2

40. 060526b, P.I. A2.A.42

A certain drug raises a patient's heart rate,  $h(x)$ , in beats per minute, according to the function  $h(x) = 70 + 0.2x$ , where  $x$  is the bloodstream drug level, in milligrams. The level of the drug in the patient's bloodstream is a function of time,  $t$ , in hours, according to the formula  $g(t) = 300(0.8)^t$ . Find the value of  $h(g(4))$ , the patient's heart rate in beats per minute, to the *nearest whole number*.

41. 060605b, P.I. A2.A.42

The temperature generated by an electrical circuit is represented by  $t = f(m) = 0.3m^2$ , where  $m$  is the number of moving parts. The resistance of the same circuit is represented by  $r = g(t) = 150 + 5t$ , where  $t$  is the temperature. What is the resistance in a circuit that has four moving parts?

- [A] 8,670    [B] 51    [C] 174    [D] 156

## CHAPTER 1-5

### IDENTIFYING FUNCTIONS AND RELATIONS

42. fall0717ia, P.I. A.G.4

Which type of graph is shown in the diagram below?

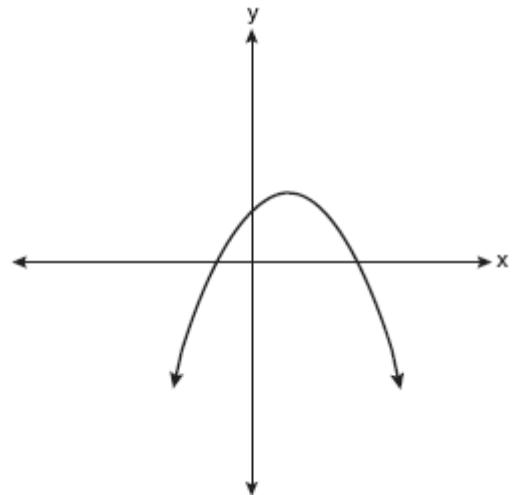

- [A] exponential    [B] absolute value  
[C] quadratic    [D] linear



43. 080723a  
When graphed on the coordinate plane, the equations  $y = 2x^2 + 4x + 5$  and  $x^2 + y^2 = 36$  form
- [A] two parabolas  
[B] a parabola and a circle  
[C] a parabola and a straight line  
[D] two circles

44. 080710b, P.I. A.G.4  
Which type of function could be used to model the data shown in the accompanying graph?

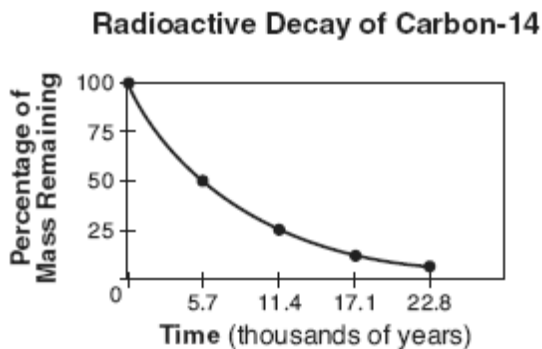

- [A] exponential      [B] quadratic  
[C] linear              [D] trigonometric
45. 080714b, P.I. A.G.4  
The graph of which function is symmetric with respect to the graph of the line  $y = x$ ?

- [A]  $y = \frac{1}{x}$               [B]  $y = \log x$   
[C]  $y = x^3$               [D]  $y = x^2$

46. 060718b, P.I. A2.A.13  
The formula  $S = 20\sqrt{t + 273}$  is used to determine the speed of sound,  $S$ , in meters per second, near Earth's surface, where  $t$  is the surface temperature, in degrees Celsius. Which graph best represents this function?

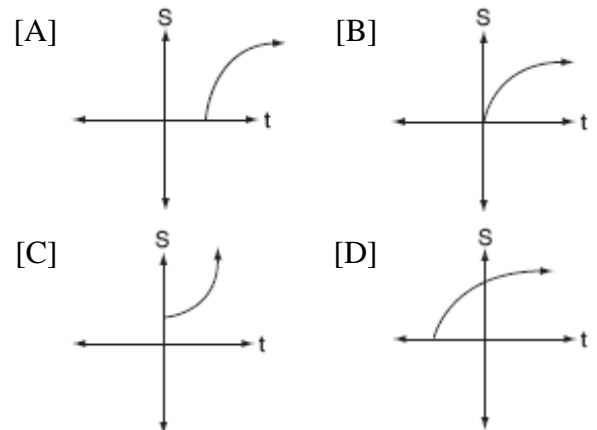

47. 060703b, P.I. A.G.4  
Which equation is best represented by the accompanying graph?

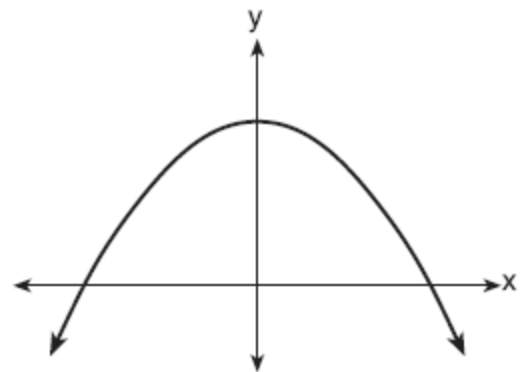

- [A]  $y = 6x^2$               [B]  $y = 6x + 1$   
[C]  $y = -x^2 + 1$         [D]  $y = 6^x$

48. 010714a  
The graph of the equation  $x^2 + y^2 = r^2$  forms
- [A] a straight line      [B] a circle  
[C] two intersecting lines      [D] a parabola

49. 010701b, P.I. A.G.4

Which equation best represents the accompanying graph?

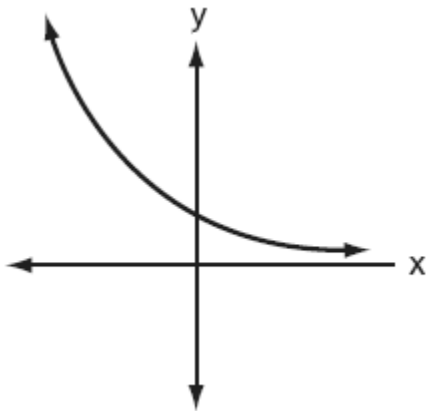

- [A]  $y = 2^{-x}$                       [B]  $y = -2^x$   
[C]  $y = 2^x$                          [D]  $y = x^2 + 2$

50. 060616b

Which equation represents a hyperbola?

- [A]  $y = 16x^2$                       [B]  $y = \frac{16}{x}$   
[C]  $y = 16 - x^2$                   [D]  $y^2 = 16 - x^2$

51. 010603b

Which graph shows that soil permeability varies inversely to runoff?

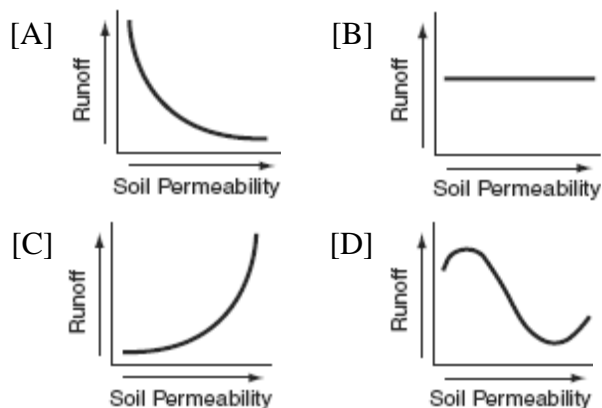

52. 080528a

The graph of the equation  $x^2 + y^2 = 4$  can be described as a

- [A] circle with its center at the origin and a radius of 4  
[B] line passing through points (0,2) and (2,0)  
[C] parabola with its vertex at (0,2)  
[D] circle with its center at the origin and a radius of 2

53. 080426a

Which equation represents the locus of points 4 units from the origin?

- [A]  $x^2 + y^2 = 4$                       [B]  $x + y = 16$   
[C]  $x^2 + y^2 = 16$                   [D]  $x = 4$

54. 060414b

Which function is symmetrical with respect to the origin?

- [A]  $y = 5^x$                               [B]  $y = \sqrt{x+5}$   
[C]  $y = |5-x|$                          [D]  $y = -\frac{5}{x}$

55. 060408b

Which graph represents an inverse variation between stream velocity and the distance from the center of the stream?

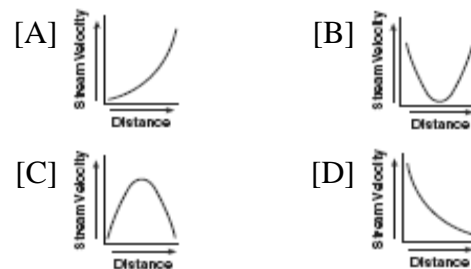

56. 010420b

The cells of a particular organism increase logarithmically. If  $g$  represents cell growth and  $h$  represents time, in hours, which graph best represents the growth pattern of the cells of this organism?

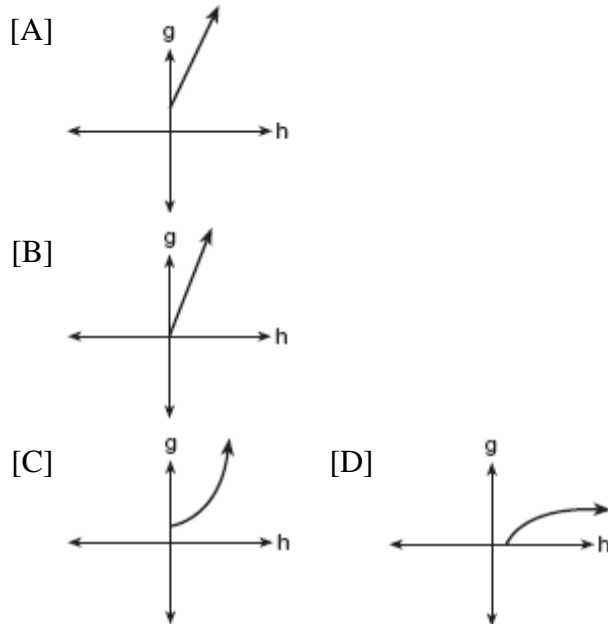

57. 010419b, P.I. A.A.41

What is the axis of symmetry of the graph of the equation  $x = y^2$ ?

- [A] line  $y = x$                       [B] line  $y = -x$   
[C]  $x$ -axis                              [D]  $y$ -axis

58. 080312b

The accompanying graph shows the relationship between a person's weight and the distance that the person must sit from the center of a seesaw to make it balanced.

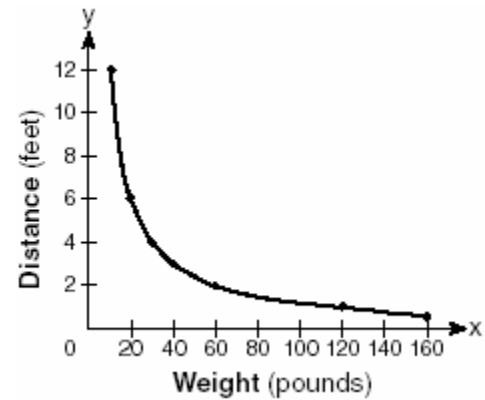

Which equation best represents this graph?

- [A]  $y = 2 \log x$                       [B]  $y = 12x^2$   
[C]  $y = -120x$                       [D]  $y = \frac{120}{x}$

59. 080304b, P.I. A.G.4

The strength of a medication over time is represented by the equation  $y = 200(1.5)^{-x}$ , where  $x$  represents the number of hours since the medication was taken and  $y$  represents the number of micrograms per millimeter left in the blood. Which graph best represents this relationship?

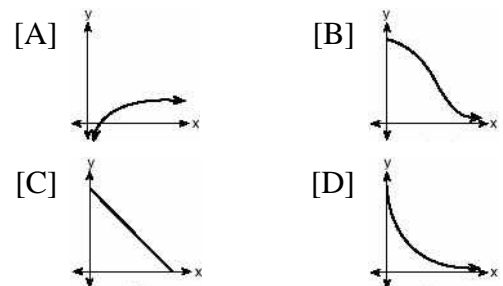

60. 060314b, P.I. A.G.4  
Which equation is represented by the accompanying graph?

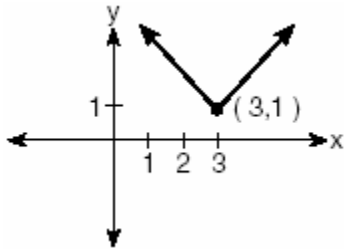

- [A]  $y = |x + 3| - 1$       [B]  $y = (x - 3)^2 + 1$   
[C]  $y = |x - 3| + 1$       [D]  $y = |x| - 3$
61. 010310b  
For a rectangular garden with a fixed area, the length of the garden varies inversely with the width. Which equation represents this situation for an area of 36 square units?
- [A]  $y = 36x$       [B]  $x + y = 36$   
[C]  $y = \frac{36}{x}$       [D]  $x - y = 36$
62. 010203b, P.I. A.G.4  
The accompanying graph represents the value of a bond over time.

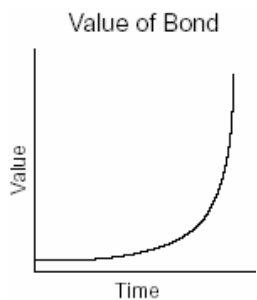

- Which type of function does this graph best model?
- [A] trigonometric      [B] exponential  
[C] quadratic      [D] logarithmic

63. 060104b, P.I. A2.A.5  
Camisha is paying a band \$330 to play at her graduation party. The amount each member earns,  $d$ , varies inversely as the number of members who play,  $n$ . The graph of the equation that represents the relationship between  $d$  and  $n$  is an example of
- [A] a hyperbola      [B] a parabola  
[C] a line      [D] an ellipse

## CHAPTER 2-4

### ABSOLUTE VALUE EQUATIONS

64. 010822b, A2.A.1  
Solve for all values of  $x$ :  $|2x - 5| = 3$
65. 080616b  
What is the solution set of the equation  $|x^2 - 2x| = 3x - 6$ ?
- [A]  $\{\pm 3\}$       [B]  $\{2, \pm 3\}$   
[C]  $\{2, 3\}$       [D]  $\{2\}$

### ABSOLUTE VALUE INEQUALITIES

66. 060107b  
Which equation states that the temperature,  $t$ , in a room is less than  $3^\circ$  from  $68^\circ$ ?
- [A]  $|3 + t| < 68$       [B]  $|68 - t| < 3$   
[C]  $|68 + t| < 3$       [D]  $|3 - t| < 68$
67. 080102b, P.I. A2.A.1  
The solution set of  $|3x + 2| < 1$  contains
- [A] only negative real numbers  
[B] no real numbers  
[C] only positive real numbers  
[D] both positive and negative real numbers

68. 060318b, P.I. A2.A.1

What is the solution set of the inequality

$$|3 - 2x| \geq 4?$$

[A]  $\{x|x \leq \frac{7}{2} \text{ or } x \geq \frac{1}{2}\}$

[B]  $\{x|x \leq -\frac{1}{2} \text{ or } x \geq \frac{7}{2}\}$

[C]  $\{x|\frac{7}{2} \leq x \leq -\frac{1}{2}\}$       [D]  $\{x|-\frac{1}{2} \leq x \leq \frac{7}{2}\}$

69. 080203b, P.I. A2.A.1

What is the solution of the inequality

$$|x + 3| \leq 5?$$

[A]  $-8 \leq x \leq 2$       [B]  $x \leq -8 \text{ or } x \geq 2$

[C]  $-2 \leq x \leq 8$       [D]  $x \leq -2 \text{ or } x \geq 8$

70. 080509b, P.I. A2.A.1

The solution of  $|2x - 3| < 5$  is

[A]  $x < -1 \text{ or } x > 4$       [B]  $x > -1$

[C]  $x < 4$       [D]  $-1 < x < 4$

71. 010610b, P.I. A2.A.1

What is the solution of the inequality

$$|y + 8| > 3?$$

[A]  $y > -5$       [B]  $-5 < y < 11$

[C]  $-11 < y < -5$       [D]  $y > -5 \text{ or } y < -11$

72. 010710b, P.I. A2.A.1

What is the solution set of the inequality

$$|2x - 1| < 9?$$

[A]  $\{x|x < -4\}$       [B]  $\{x|x < 5\}$

[C]  $\{x|x < -4 \text{ or } x > 5\}$

[D]  $\{x|-4 < x < 5\}$

73. 080303b, P.I. A2.A.1

Which graph represents the solution set of

$$|2x - 1| < 7?$$

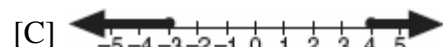
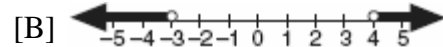
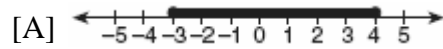

74. 060505b, P.I. A2.A.1

Which graph represents the solution set for the expression  $|2x + 3| > 7?$

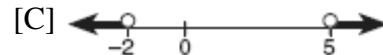

75. 060707b, P.I. A2.A.1

Which inequality is represented by the accompanying graph?



[A]  $|x + 3| \geq 2$       [B]  $|x + 2| > 5$

[C]  $|x - 1| \leq 5$       [D]  $|x - 5| \geq 2$

76. 060617b, P.I. A2.A.1

The solution set of which inequality is represented by the accompanying graph?

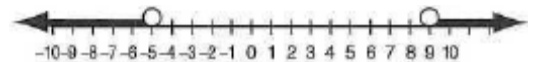

[A]  $|x - 2| > 7$       [B]  $|x - 2| < 7$

[C]  $|2 - x| < -7$       [D]  $|2 - x| > -7$

77. 010326b, P.I. A2.A.1

The inequality  $|15C - 24| \leq 30$  represents the range of monthly average temperatures,  $C$ , in degrees Celsius, for Toledo, Ohio. Solve for  $C$ .

78. 010531b, P.I. A2.A.1

The heights,  $h$ , of the students in the chorus at Central Middle School satisfy the inequality

$$\left| \frac{h - 57.5}{2} \right| \leq 3.25, \text{ when } h \text{ is measured in}$$

*inches*. Determine the interval in which these heights lie and express your answer to the *nearest tenth of a foot*. [Only an algebraic solution can receive full credit.]

79. 080427b, P.I. A2.A.1

A depth finder shows that the water in a certain place is 620 feet deep. The difference between  $d$ , the actual depth of the water, and the reading is  $|d - 620|$  and must be less than or equal to  $0.05d$ . Find the minimum and maximum values of  $d$ , to the *nearest tenth of a foot*.

81. 010414b, P.I. A.G.4

The graph below represents  $f(x)$ .

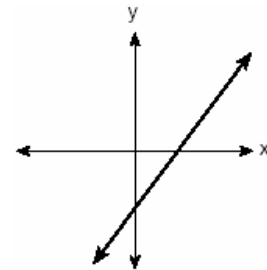

Which graph best represents  $|f(x)|$ ?

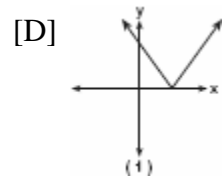
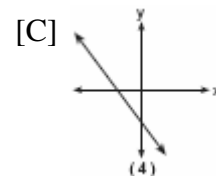
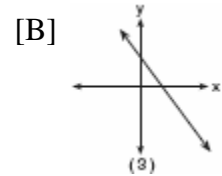
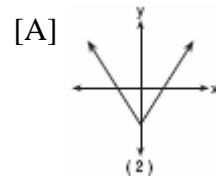

## CHAPTER 2-5

### ABSOLUTE VALUE

80. 080707b, P.I. A.G.4

Which equation represents the function shown in the accompanying graph?

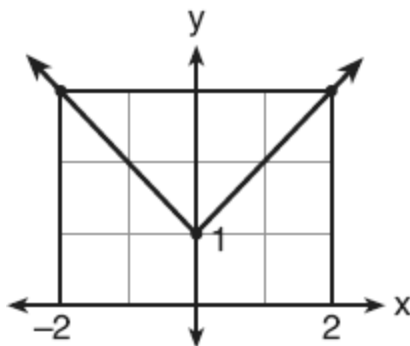

[A]  $f(x) = |x| + 1$       [B]  $f(x) = |x - 1|$

[C]  $f(x) = |x + 1|$       [D]  $f(x) = |x| - 1$

82. fall0722ia, P.I. A.G.4

The diagram below shows the graph of  
 $y = |x - 3|$ .

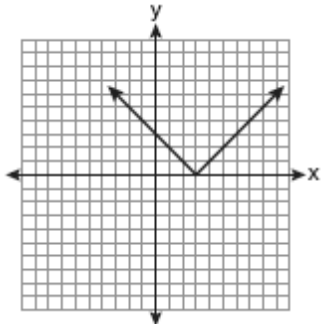

Which diagram shows the graph of  
 $y = -|x - 3|$ ?

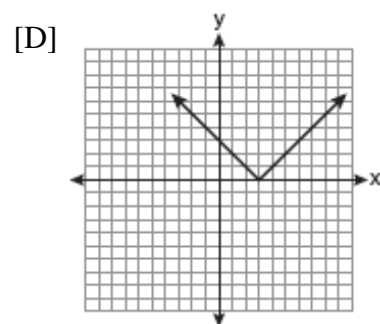
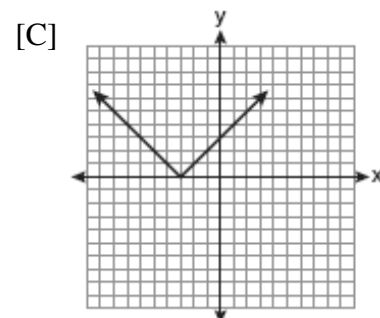
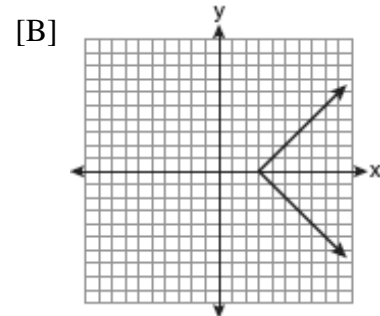
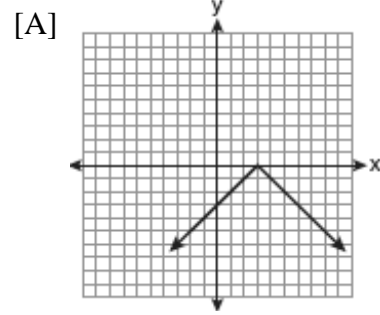

## CHAPTER 5-2

### MINIMUM AND MAXIMUM OF QUADRATICS

83. 080501b, P.I. A.A.41

What is the turning point, or vertex, of the parabola whose equation is  $y = 3x^2 + 6x - 1$ ?

[A] (1,8)

[B] (3,44)

[C] (-1,-4)

[D] (-3,8)

84. 080603b, P.I. A.A.41  
What is the minimum point of the graph of the equation  $y = 2x^2 + 8x + 9$ ?
- [A] (-2,-15)                      [B] (-2,1)  
[C] (2,33)                         [D] (2,17)
85. 060101b, P.I. A.A.8  
An archer shoots an arrow into the air such that its height at any time,  $t$ , is given by the function  $h(t) = -16t^2 + kt + 3$ . If the maximum height of the arrow occurs at time  $t = 4$ , what is the value of  $k$ ?
- [A] 128    [B] 64    [C] 8    [D] 4
86. 010322b, P.I. A.A.8  
The height of an object,  $h(t)$ , is determined by the formula  $h(t) = -16t^2 + 256t$ , where  $t$  is time, in seconds. Will the object reach a maximum or a minimum? Explain or show your reasoning.
87. 060321b, P.I. A.A.41  
Vanessa throws a tennis ball in the air. The function  $h(t) = -16t^2 + 45t + 7$  represents the distance, in feet, that the ball is from the ground at any time  $t$ . At what time, to the *nearest tenth of a second*, is the ball at its maximum height?
88. 080321b, P.I. A.A.41  
The height,  $h$ , in feet, a ball will reach when thrown in the air is a function of time,  $t$ , in seconds, given by the equation  $h(t) = -16t^2 + 30t + 6$ . Find, to the *nearest tenth*, the maximum height, in feet, the ball will reach.
89. 010424b, P.I. A.A.41  
When a current,  $I$ , flows through a given electrical circuit, the power,  $W$ , of the circuit can be determined by the formula  $W = 120I - 12I^2$ . What amount of current,  $I$ , supplies the maximum power,  $W$ ?

90. 060225b, P.I. A.A.41  
The equation  $W = 120I - 12I^2$  represents the power ( $W$ ), in watts, of a 120-volt circuit having a resistance of 12 ohms when a current ( $I$ ) is flowing through the circuit. What is the maximum power, in watts, that can be delivered in this circuit?
91. 060430b, P.I. A.A.41  
A baseball player throws a ball from the outfield toward home plate. The ball's height above the ground is modeled by the equation  $y = -16x^2 + 48x + 6$  where  $y$  represents height, in feet, and  $x$  represents time, in seconds. The ball is initially thrown from a height of 6 feet. How many seconds after the ball is thrown will it again be 6 feet above the ground? What is the maximum height, in feet, that the ball reaches? [The use of the accompanying grid is optional.]

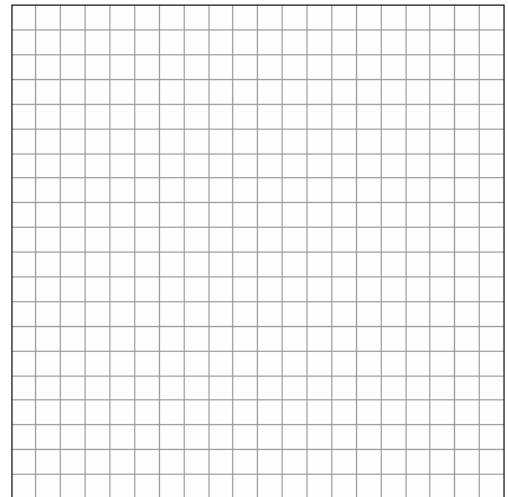



92. 080229b, P.I. A.A.41

A rock is thrown vertically from the ground with a velocity of 24 meters per second, and it reaches a height of  $2 + 24t - 4.9t^2$  after  $t$  seconds. How many seconds after the rock is thrown will it reach maximum height, and what is the maximum height the rock will reach, in meters? How many seconds after the rock is thrown will it hit the ground? Round your answers to the *nearest hundredth*. [Only an algebraic or graphic solution will be accepted.]

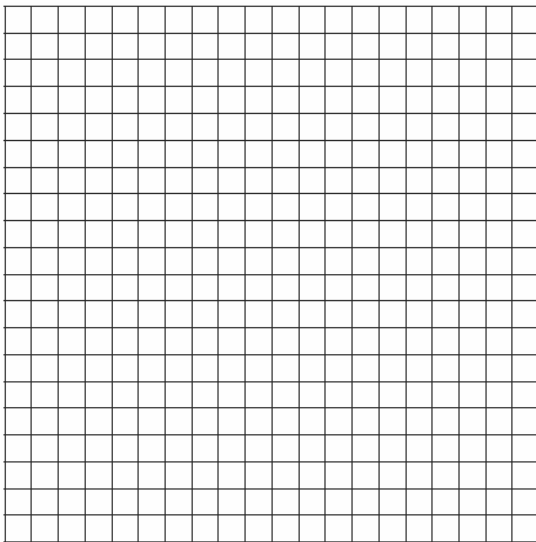

93. 060732b, P.I. A.A.41

The path of a rocket fired during a fireworks display is given by the equation  $s(t) = 64t - 16t^2$ , where  $t$  is the time, in seconds, and  $s$  is the height, in feet. What is the maximum height, in feet, the rocket will reach? In how many seconds will the rocket hit the ground? [The grid is optional.]

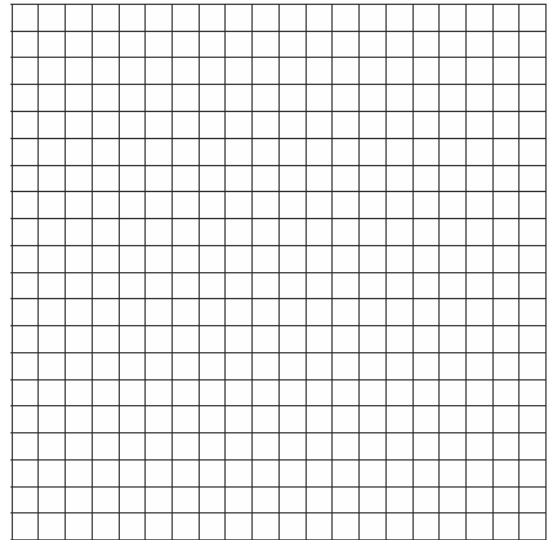

94. 010834b, P.I. A.A.41

The members of the Lincoln High School Prom Committee are trying to raise money for their senior prom. They plan to sell teddy bears. The senior advisor told them that the profit equation for their project is

$y = -0.1x^2 + 9x - 50$ , where  $x$  is the price at which the teddy bears will be sold and  $y$  is the profit, in dollars. On the grid below, graph this relationship so that  $0 \leq x \leq 90$  and  $-50 \leq y \leq 160$ . How much profit can the committee expect to make if they sell the teddy bears for \$20 each? What price should they charge for the teddy bears to make the maximum profit possible?

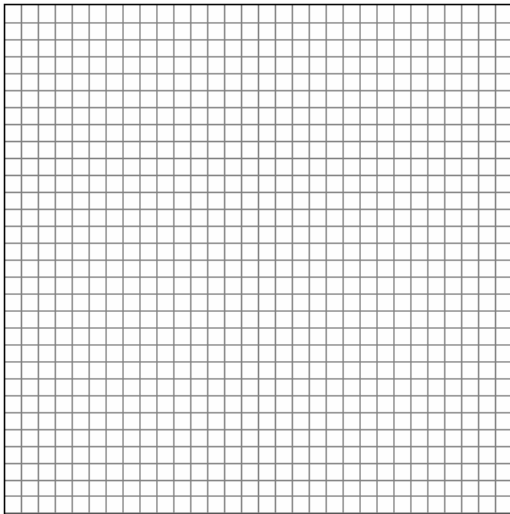

## CHAPTER 5-4

### INVERSE OF FUNCTIONS

95. 010209b, P.I. A2.A.44

If a function is defined by the equation  $y = 3x + 2$ , which equation defines the inverse of this function?

[A]  $x = \frac{1}{3}y + \frac{1}{2}$       [B]  $y = \frac{1}{3}x - \frac{2}{3}$

[C]  $y = -3x - 2$       [D]  $y = \frac{1}{3}x + \frac{1}{2}$

96. 080205b, P.I. A2.A.44

A function is defined by the equation  $y = 5x - 5$ . Which equation defines the inverse of this function?

[A]  $x = \frac{1}{5y-5}$       [B]  $y = \frac{1}{5x-5}$

[C]  $x = 5y - 5$       [D]  $y = 5x + 5$

97. 080319b, P.I. A2.A.44

A function is defined by the equation  $y = \frac{1}{2}x - \frac{3}{2}$ . Which equation defines the inverse of this function?

[A]  $y = 2x + 3$       [B]  $y = 2x - 3$

[C]  $y = 2x + \frac{3}{2}$       [D]  $y = 2x - \frac{3}{2}$

98. 010332b, P.I. A2.A.44

Given:  $f(x) = x^2$  and  $g(x) = 2^x$

a The inverse of  $g$  is a function, but the inverse of  $f$  is not a function. Explain why this statement is true.

b Find  $g^{-1}(f(3))$  to the nearest tenth.

99. 080216b

If the point  $(a, b)$  lies on the graph  $y = f(x)$ , the graph of  $y = f^{-1}(x)$  must contain point

[A]  $(a,0)$       [B]  $(b,a)$

[C]  $(0,b)$       [D]  $(-a,-b)$

100. 060220b, P.I. A2.A.44

Which graph represents the inverse of  $f(x) = \{(0,1), (1,4), (2,3)\}$ ?

[A]

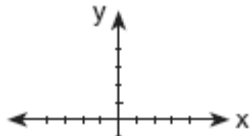

[B]

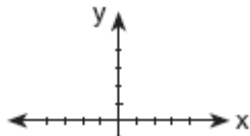

[C]

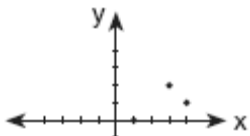

[D]

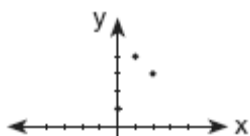

101. 060130b, P.I. A2.A.44

Draw  $f(x) = 2x^2$  and  $f^{-1}(x)$  in the interval  $0 \leq x \leq 2$  on the accompanying set of axes. State the coordinates of the points of intersection.

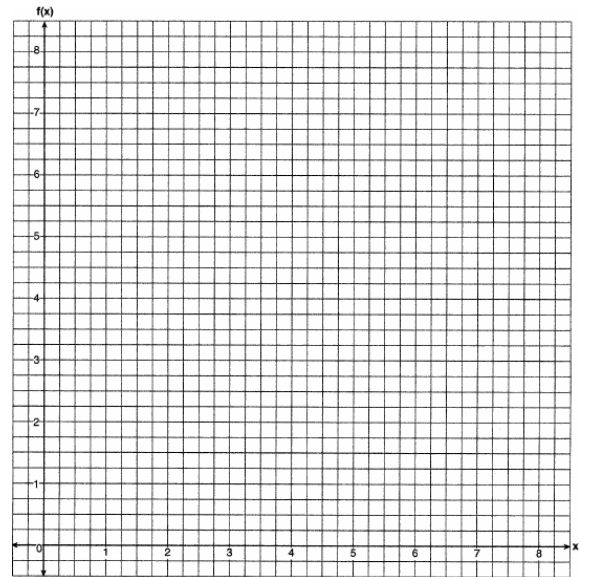

102. 010521b, P.I. A2.A.44

The accompanying diagram shows the graph of the line whose equation is  $y = -\frac{1}{3}x + 2$ . On the same set of axes, sketch the graph of the inverse of this function. State the coordinates of a point on the inverse function.

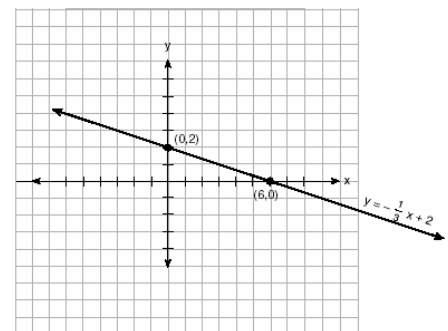

103. 080712b, P.I. A2.A.44  
Which graph has an inverse that is a function?

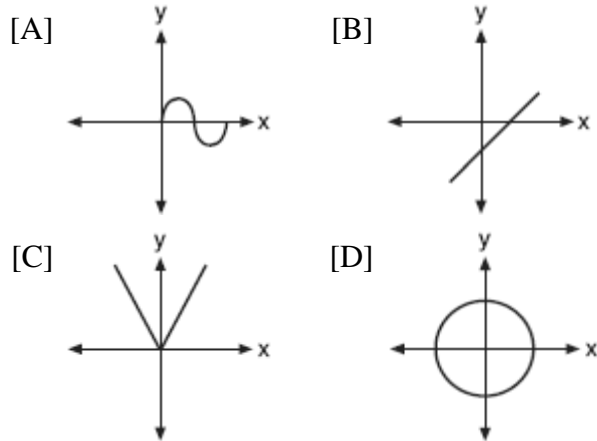

104. 080416b, P.I. A2.A.44  
What is the inverse of the function  
 $y = \log_4 x$ ?

- [A]  $4^y = x$                       [B]  $4^x = y$   
[C]  $x^4 = y$                       [D]  $y^4 = x$

105. 060115b, P.I. A2.A.44  
The inverse of a function is a logarithmic function in the form  $y = \log_b x$ . Which equation represents the original function?

- [A]  $by = x$                       [B]  $x = b^y$   
[C]  $y = b^x$                       [D]  $y = bx$

## CHAPTER 5-6

### IMAGINARY NUMBERS

106. 010705b, P.I. A2.N.7  
The expression  $i^{25}$  is equivalent to  
[A]  $i$       [B]  $-1$       [C]  $1$       [D]  $-i$

107. 060615b, P.I. A2.N.7  
Mrs. Donahue made up a game to help her class learn about imaginary numbers. The winner will be the student whose expression is equivalent to  $-i$ . Which expression will win the game?

- [A]  $i^{49}$       [B]  $i^{48}$       [C]  $i^{46}$       [D]  $i^{47}$

108. 080215b, P.I. A2.N.9  
Expressed in simplest form,  $i^{16} + i^6 - 2i^5 + i^{13}$

- [A]  $1$       [B]  $-1$       [C]  $-i$       [D]  $i$

109. 080407b, P.I. A2.N.9  
When simplified,  $i^{27} + i^{34}$  is equal to

- [A]  $-i-1$       [B]  $i-1$       [C]  $i$       [D]  $i^{61}$

110. 060315b, P.I. A2.N.9  
What is the value of  $i^{99} - i^3$ ?

- [A]  $i^{96}$       [B]  $-i$       [C]  $0$       [D]  $1$

111. 060215b, P.I. A2.N.9  
What is the sum of  $\sqrt{-2}$  and  $\sqrt{-18}$ ?

- [A]  $2i\sqrt{5}$                       [B]  $6i$   
[C]  $4i\sqrt{2}$                       [D]  $5i\sqrt{2}$

112. 060410b, P.I. A2.N.9  
The expression  $i^0 \cdot i^1 \cdot i^2 \cdot i^3 \cdot i^4$  is equal to  
[A]  $i$       [B]  $-i$       [C]  $1$       [D]  $-1$

113. 010518b, P.I. A2.N.9  
The expression  $\frac{i^{16}}{i^3}$  is equivalent to

- [A]  $1$       [B]  $i$       [C]  $-1$       [D]  $-i$

114. 060614b  
What is the multiplicative inverse of  $3i$ ?

- [A]  $\frac{1}{3}$       [B]  $-3$       [C]  $-3i$       [D]  $-\frac{i}{3}$

**COMPLEX NUMBERS**

115. 060108b  
Fractal geometry uses the complex number plane to draw diagrams, such as the one shown in the accompanying graph.

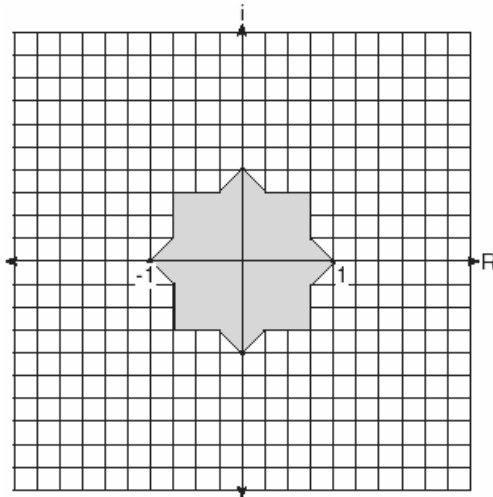

Which number is *not* included in the shaded area?

- [A]  $-0.9 - 0.9i$       [B]  $-0.5 - 0.5i$   
[C]  $-0.5i$       [D]  $-0.9$
116. 080512b  
Two complex numbers are graphed below.

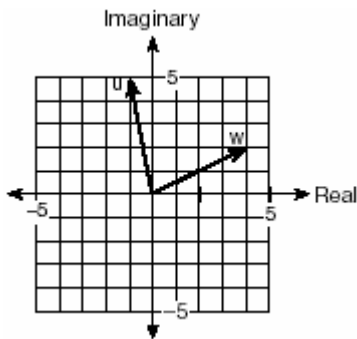

What is the sum of  $w$  and  $u$ , expressed in standard complex number form?

- [A]  $7 + 3i$       [B]  $5 + 7i$   
[C]  $-5 + 3i$       [D]  $3 + 7i$

117. 060726b  
On a stamp honoring the German mathematician Carl Gauss, several complex numbers appear. The accompanying graph shows two of these numbers. Express the sum of these numbers in  $a + bi$  form.

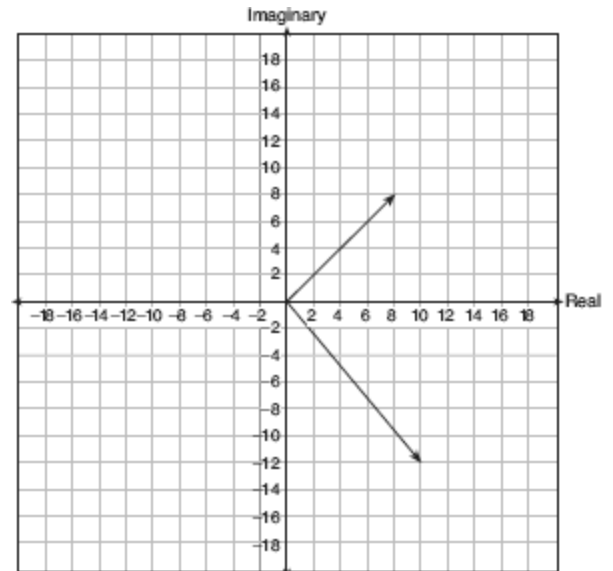

118. 060621b  
Find the sum of  $-2 + 3i$  and  $-1 - 2i$ . Graph the resultant on the accompanying set of axes.

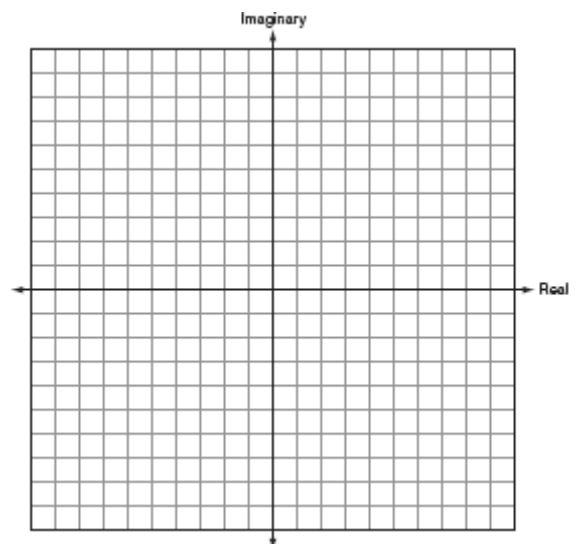

119. 010724b, P.I. A2.A.4

On the accompanying set of axes, graphically represent the sum of  $3 + 4i$  and  $-1 + 2i$ .

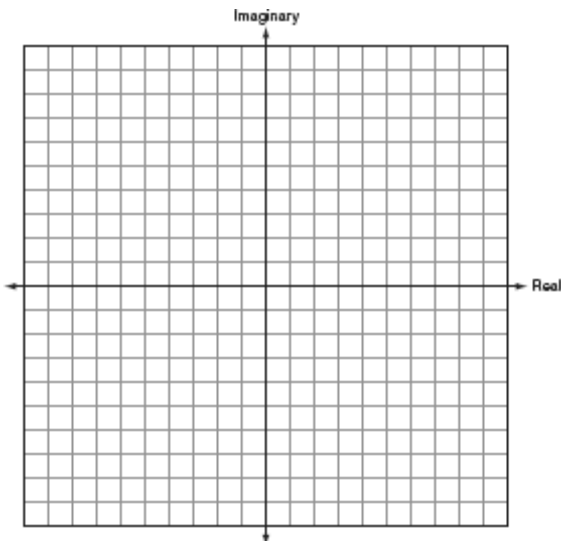

120. 060111b, P.I. A2.N.9

Melissa and Joe are playing a game with complex numbers. If Melissa has a score of  $5 - 4i$  and Joe has a score of  $3 + 2i$ , what is their total score?

- [A]  $8 + 6i$                       [B]  $8 + 2i$   
[C]  $8 - 2i$                       [D]  $8 - 6i$

121. 080422b, P.I. A2.N.9

Express  $\sqrt{-48} + 3.5 + \sqrt{25} + \sqrt{-27}$  in simplest  $a + bi$  form.

122. 060401b, P.I. A2.N.9

What is the sum of  $2 - \sqrt{-4}$  and  $-3 + \sqrt{-16}$  expressed in simplest  $a + bi$  form?

- [A]  $-1 + i\sqrt{20}$                   [B]  $-14 + i$   
[C]  $-1 + 2i$                       [D]  $-1 + 12i$

123. 080507b, P.I. A2.N.9

When expressed as a monomial in terms of  $i$ ,  $2\sqrt{-32} - 5\sqrt{-8}$  is equivalent to

- [A]  $18i\sqrt{2}$                       [B]  $2\sqrt{2}i$   
[C]  $-2i\sqrt{2}$                       [D]  $2i\sqrt{2}$

124. 080314b, P.I. A2.N.9

What is the product of  $5 + \sqrt{-36}$  and  $1 - \sqrt{-49}$ , expressed in simplest  $a + bi$  form?

- [A]  $-37 + 41i$                   [B]  $47 - 29i$   
[C]  $5 - 71i$                       [D]  $47 + 41i$

125. 080122b, P.I. A2.N.9

Show that the product of  $a + bi$  and its conjugate is a real number.

126. 010325b, P.I. A2.N.9

In an electrical circuit, the voltage,  $E$ , in volts, the current,  $I$ , in amps, and the opposition to the flow of current, called impedance,  $Z$ , in ohms, are related by the equation  $E = IZ$ . A circuit has a current of  $(3 + i)$  amps and an impedance of  $(-2 + i)$  ohms. Determine the voltage in  $a + bi$  form.

127. 060304b, P.I. A2.N.9

The relationship between voltage,  $E$ , current,  $I$ , and resistance,  $Z$ , is given by the equation  $E = IZ$ . If a circuit has a current  $I = 3 + 2i$  and a resistance  $Z = 2 - i$ , what is the voltage of this circuit?

- [A]  $8 + 7i$     [B]  $4 - i$     [C]  $8 + i$     [D]  $4 + i$

128. 080702b, P.I. A2.N.9

The expression  $3i(2i^2 - 5i)$  is equivalent to

- [A]  $-1 + 0i$                       [B]  $15 - 6i$   
[C]  $15 - 5i$                       [D]  $-15 - 5i$

129. 080621b, P.I. A2.N.9

The complex number  $c + di$  is equal to  $(2 + i)^2$ . What is the value of  $c$ ?

130. 010219b, P.I. A2.N.9

The expression  $(-1 + i)^3$  is equivalent to

- [A]  $2 + 2i$                       [B]  $-2 - 2i$   
[C]  $-3i$                           [D]  $-1 - i$

131. 010415b, P.I. A2.N.9  
If  $f(x) = x^3 - 2x^2$ , then  $f(i)$  is equivalent to  
[A]  $-2 + i$  [B]  $2 - i$  [C]  $-2 - i$  [D]  $2 + i$

132. 080302b, P.I. A2.A.22  
What is the value of  $x$  in the equation  
 $\sqrt{5-2x} = 3i$ ?  
[A] 1 [B] 7 [C] 4 [D] -2

133. 010811b, P.I. A2.N.9  
The expression  $\frac{10}{3+i}$  is equivalent to  
[A]  $3+i$  [B]  $\frac{5}{4}$   
[C]  $\frac{15+5i}{4}$  [D]  $3-i$

134. 060513b, P.I. A2.N.9  
The expression  $\frac{2+i}{3+i}$  is equivalent to  
[A]  $\frac{7-5i}{10}$  [B]  $\frac{6+i}{8}$   
[C]  $\frac{7+i}{10}$  [D]  $\frac{6+5i}{8}$

135. 060509b, P.I. A2.N.9  
Impedance measures the opposition of an electrical circuit to the flow of electricity. The total impedance in a particular circuit is given by the formula  $Z_T = \frac{Z_1 Z_2}{Z_1 + Z_2}$ . What is the total impedance of a circuit,  $Z_T$ , if  $Z_1 = 1 + 2i$  and  $Z_2 = 1 - 2i$ ?  
[A]  $-\frac{3}{2}$  [B]  $\frac{5}{2}$  [C] 1 [D] 0

## CHAPTER 5-8

### QUADRATICS WITH NONINTEGER SOLUTIONS

136. 060104a, P.I. A2.A.7  
One root of the equation  $2x^2 - x - 15 = 0$  is  
[A] -3 [B] 3 [C]  $\frac{5}{2}$  [D]  $\frac{3}{2}$

137. 010419a, P.I. A2.A.7  
What is the solution set of the equation  
 $3x^2 - 34x - 24 = 0$ ?  
[A]  $\{-12, \frac{2}{3}\}$  [B]  $\{-6, 2\}$   
[C]  $\{-\frac{2}{3}, 12\}$  [D]  $\{-2, 6\}$

138. 080112b, P.I. A.A.8  
A ball is thrown straight up at an initial velocity of 54 feet per second. The height of the ball  $t$  seconds after it is thrown is given by the formula  $h(t) = 54t - 12t^2$ . How many seconds after the ball is thrown will it return to the ground?  
[A] 9.2 [B] 4 [C] 6 [D] 4.5

139. 080217b  
If the sum of the roots of  $x^2 + 3x - 5$  is added to the product of its roots, the result is  
[A] -15 [B] 15 [C] -8 [D] -2

140. 080634b, P.I. A2.A.25  
Barb pulled the plug in her bathtub and it started to drain. The amount of water in the bathtub as it drains is represented by the equation  $L = -5t^2 - 8t + 120$ , where  $L$  represents the number of liters of water in the bathtub and  $t$  represents the amount of time, in minutes, since the plug was pulled. How many liters of water were in the bathtub when Barb pulled the plug? Show your reasoning. Determine, to the *nearest tenth of a minute*, the amount of time it takes for all the water in the bathtub to drain.
141. 010729b, P.I. A2.A.25  
Matt's rectangular patio measures 9 feet by 12 feet. He wants to increase the patio's dimensions so its area will be twice the area it is now. He plans to increase both the length and the width by the same amount,  $x$ . Find  $x$ , to the *nearest hundredth of a foot*.
142. 060128b, P.I. A2.A.25  
A homeowner wants to increase the size of a rectangular deck that now measures 15 feet by 20 feet, but building code laws state that a homeowner cannot have a deck larger than 900 square feet. If the length and the width are to be increased by the same amount, find, to the *nearest tenth*, the maximum number of feet that the length of the deck may be increased in size legally.
143. 080727b, P.I. A2.A.25  
A rectangular patio measuring 6 meters by 8 meters is to be increased in size to an area measuring 150 square meters. If both the width and the length are to be increased by the same amount, what is the number of meters, to the *nearest tenth*, that the dimensions will be increased?
144. 010522b  
If  $2 + 3i$  is one root of a quadratic equation with real coefficients, what is the sum of the roots of the equation?
145. 080328b, P.I. A2.A.25  
Express, in simplest  $a + bi$  form, the roots of the equation  $x^2 + 5 = 4x$ .
146. 010222b, P.I. A2.A.25  
Solve for  $x$  in simplest  $a + bi$  form:  
 $x^2 + 8x + 25 = 0$
147. 010627b, P.I. A2.A.25  
In physics class, Taras discovers that the behavior of electrical power,  $x$ , in a particular circuit can be represented by the function  $f(x) = x^2 + 2x + 7$ . If  $f(x) = 0$ , solve the equation and express your answer in simplest  $a + bi$  form.
148. 080612b, P.I. A.A.8  
For which equation is the sum of the roots equal to the product of the roots?  
[A]  $x^2 + 3x - 6 = 0$  [B]  $x^2 + x + 1 = 0$   
[C]  $x^2 - 8x - 4 = 0$  [D]  $x^2 - 4x + 4 = 0$
149. 080718b  
Which equation has the complex number  $4 - 3i$  as a root?  
[A]  $x^2 - 8x + 25 = 0$  [B]  $x^2 - 6x + 25 = 0$   
[C]  $x^2 + 8x - 25 = 0$  [D]  $x^2 + 6x - 25 = 0$
150. 010714b  
Which quadratic equation has the roots  $3 + i$  and  $3 - i$ ?  
[A]  $x^2 + 6x - 10 = 0$  [B]  $x^2 + 6x + 8 = 0$   
[C]  $x^2 - 6x - 8 = 0$  [D]  $x^2 - 6x + 10 = 0$
151. 060719b  
If  $2 + i$  and  $2 - i$  are the roots of the equation  $x^2 - 4x + c = 0$ , what is the value of  $c$ ?  
[A] 5 [B] -4 [C] -5 [D] 4



**USING THE DISCRIMINANT**

152. 010201b, P.I. A2.A.2  
The roots of a quadratic equation are real, rational, and equal when the discriminant is  
[A] 2 [B] 4 [C] 0 [D] -2
153. 060717b, P.I. A2.A.2  
Which number is the discriminant of a quadratic equation whose roots are real, unequal, and irrational?  
[A] 0 [B] 4 [C] -5 [D] 7
154. 060103b, P.I. A2.A.2  
Jacob is solving a quadratic equation. He executes a program on his graphing calculator and sees that the roots are real, rational, and unequal. This information indicates to Jacob that the discriminant is  
[A] zero [B] negative  
[C] not a perfect square  
[D] a perfect square
155. 080106b, P.I. A2.A.2  
The roots of the equation  $x^2 - 3x - 2 = 0$  are  
[A] real, rational, and unequal  
[B] real, irrational, and unequal  
[C] imaginary  
[D] real, rational, and equal
156. 010513b, P.I. A2.A.2  
The roots of the equation  $2x^2 - 8x - 4 = 0$  are  
[A] real, irrational, and unequal  
[B] real, rational, and equal  
[C] imaginary  
[D] real, rational, and unequal
157. 060219b, P.I. A2.A.2  
The roots of the equation  $2x^2 - x = 4$  are  
[A] real, rational, and equal  
[B] real and irrational  
[C] real, rational, and unequal  
[D] imaginary
158. 010614b, P.I. A2.A.2  
The roots of the equation  $2x^2 - 5 = 0$  are  
[A] imaginary  
[B] real, rational, and unequal  
[C] real, rational, and equal  
[D] real and irrational
159. 010817b, P.I. A2.A.2  
Which equation has roots that are real, rational, and unequal?  
[A]  $x^2 - 4 = 0$  [B]  $x^2 - 4x + 4 = 0$   
[C]  $x^2 - 2 = 0$  [D]  $x^2 + x + 1 = 0$
160. 080211b, P.I. A2.A.2  
Which equation has imaginary roots?  
[A]  $x^2 - 1 = 0$  [B]  $x^2 - x - 1 = 0$   
[C]  $x^2 + x + 1 = 0$  [D]  $x^2 - 2 = 0$
161. 060518b, P.I. A2.A.2  
Which equation has imaginary roots?  
[A]  $(2x + 1)(x - 3) = 7$  [B]  $x(5 + x) = 8$   
[C]  $x(5 - x) = -3$  [D]  $x(x + 6) = -10$
162. 080516b, P.I. A2.A.2  
For which positive value of  $m$  will the equation  $4x^2 + mx + 9 = 0$  have roots that are real, equal, and rational?  
[A] 4 [B] 9 [C] 12 [D] 3

163. 060307b, P.I. A2.A.2  
The roots of the equation  $ax^2 + 4x = -2$  are real, rational, and equal when  $a$  has a value of  
[A] 2      [B] 3      [C] 1      [D] 4
164. 080320b, P.I. A2.A.2  
In the equation  $ax^2 + 6x - 9 = 0$ , imaginary roots will be generated if  
[A]  $a < -1$                       [B]  $a < 1$ , only  
[C]  $a > -1$ , only                  [D]  $-1 < a < 1$
165. 080411b, P.I. A2.A.2  
The equation  $2x^2 + 8x + n = 0$  has imaginary roots when  $n$  is equal to  
[A] 10      [B] 6      [C] 4      [D] 8
166. 060423b, P.I. A2.A.2  
Find all values of  $k$  such that the equation  $3x^2 - 2x + k = 0$  has imaginary roots.
167. 080525b  
Given the function  $y = f(x)$ , such that the entire graph of the function lies above the  $x$ -axis. Explain why the equation  $f(x) = 0$  has no real solutions.
168. 010416b, P.I. A2.A.2  
Which statement must be true if a parabola represented by the equation  $y = ax^2 + bx + c$  does not intersect the  $x$ -axis?  
[A]  $b^2 - 4ac > 0$ , and  $b^2 - 4ac$  is not a perfect square.  
[B]  $b^2 - 4ac > 0$ , and  $b^2 - 4ac$  is a perfect square.  
[C]  $b^2 - 4ac < 0$                   [D]  $b^2 - 4ac = 0$
169. 010313b, P.I. A2.A.2  
If the roots of  $ax^2 + bx + c = 0$  are real, rational, and equal, what is true about the graph of the function  $y = ax^2 + bx + c$ ?  
[A] It lies entirely below the  $x$ -axis.  
[B] It is tangent to the  $x$ -axis.  
[C] It intersects the  $x$ -axis in two distinct points.  
[D] It lies entirely above the  $x$ -axis.
170. 010713b, P.I. A2.A.2  
Which is a true statement about the graph of the equation  $y = x^2 - 7x - 60$ ?  
[A] It intersects the  $x$ -axis in two distinct points that have irrational coordinates.  
[B] It does not intersect the  $x$ -axis.  
[C] It intersects the  $x$ -axis in two distinct points that have rational coordinates.  
[D] It is tangent to the  $x$ -axis.

171. 080620b

Which graph represents a quadratic function with a negative discriminant?

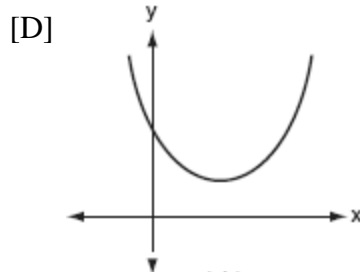
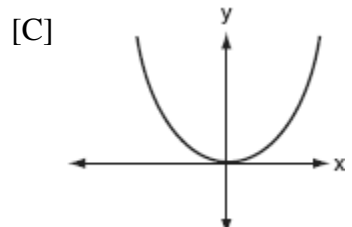
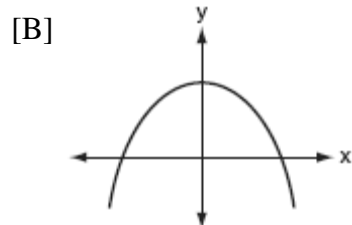
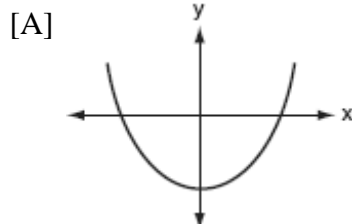

173. 010318b, P.I. A2.A.4

Which graph represents the solution set of  $x^2 - x - 12 < 0$ ?

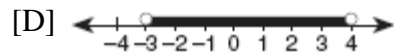
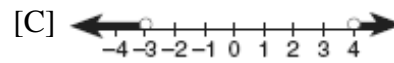
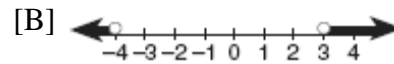
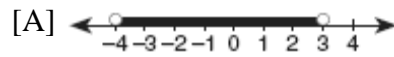

174. 080713b, P.I. A2.A.4

What is the solution set of the inequality  $x^2 + 4x - 5 < 0$ ?

[A]  $\{x|x < -5 \text{ or } x > 1\}$

[B]  $\{x|-5 < x < 1\}$       [C]  $\{x|-1 < x < 5\}$

[D]  $\{x|x < -1 \text{ or } x > 5\}$

175. 010231b, P.I. A2.A.4

When a baseball is hit by a batter, the height of the ball,  $h(t)$ , at time  $t$ ,  $t \geq 0$ , is determined by the equation  $h(t) = -16t^2 + 64t + 4$ . For which interval of time is the height of the ball greater than or equal to 52 feet?

## NY LESSON 2

### QUADRATIC INEQUALITIES

172. 010509b, P.I. A2.A.4

Which graph represents the solution set of the inequality  $x^2 - 4x - 5 < 0$ ?

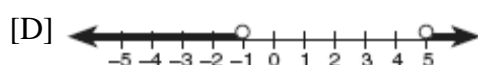
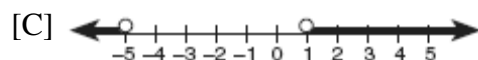
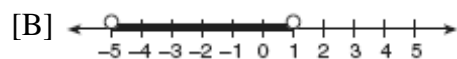
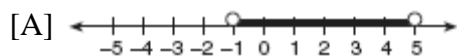

176. 060632b, P.I. A.G.4

A small rocket is launched from a height of 72 feet. The height of the rocket in feet,  $h$ , is represented by the equation

$$h(t) = -16t^2 + 64t + 72, \text{ where } t = \text{time, in}$$

seconds. Graph this equation on the accompanying grid. Use your graph to determine the number of seconds that the rocket will remain at or above 100 feet from the ground. [Only a graphic solution can receive full credit.]

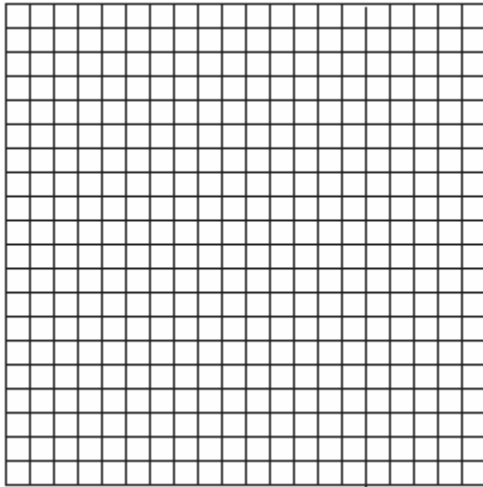

177. 060532b, P.I. A2.A.4

The height of a projectile is modeled by the equation  $y = -2x^2 + 38x + 10$ , where  $x$  is time, in seconds, and  $y$  is height, in feet. During what interval of time, to the nearest tenth of a second, is the projectile at least 125 feet above ground? [The use of the accompanying grid is optional.]

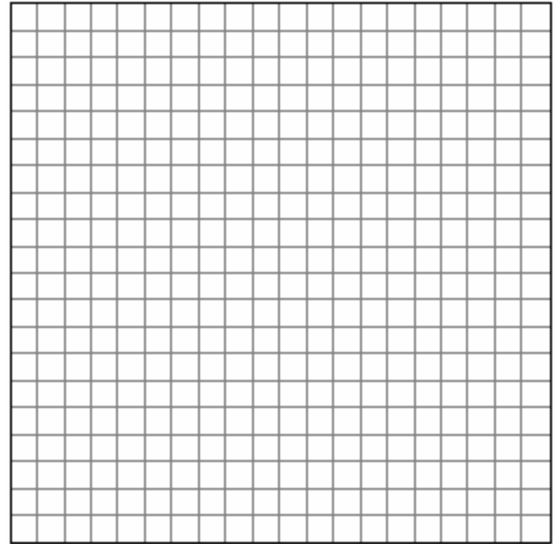

178. 080424b, P.I. A2.A.4

The profit a coat manufacturer makes each day is modeled by the equation

$P(x) = -x^2 + 120x - 2000$ , where  $P$  is the profit and  $x$  is the price for each coat sold.

For what values of  $x$  does the company make a profit? [The use of the accompanying grid is optional.]

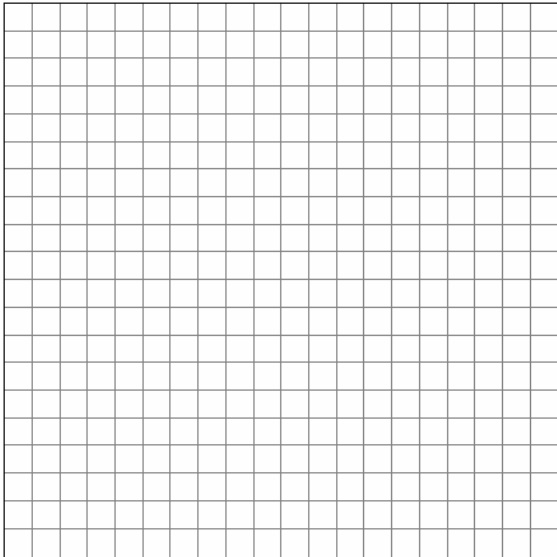

179. 080531b, P.I. A2.A.4

The profit,  $P$ , for manufacturing a wireless device is given by the equation

$P = -10x^2 + 750x - 9,000$ , where  $x$  is the selling price, in dollars, for each wireless device.

What range of selling prices allows the manufacturer to make a profit on this wireless device? [The use of the grid is optional.]

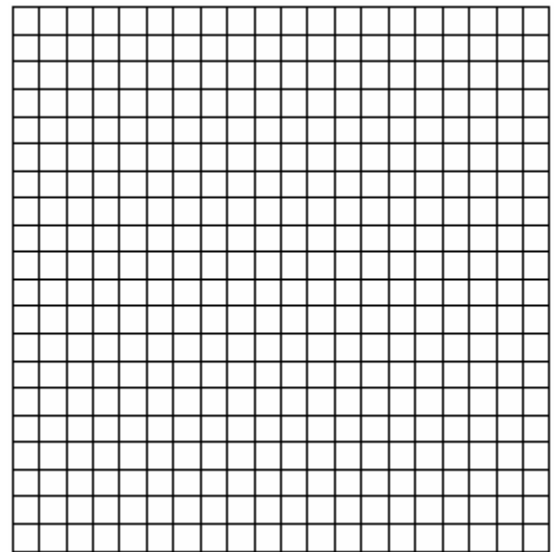

## NY LESSON 7

### REGRESSION

180. 060209b, P.I. A2.S.7

What is the equation of a parabola that goes through points (0,1), (-1,6), and (2,3)?

[A]  $y = x^2 - 3x + 1$       [B]  $y = 2x^2 + 1$

[C]  $y = 2x^2 - 3x + 1$       [D]  $y = x^2 + 1$

## CHAPTER 6-1

### EXPONENTS AS RADICALS

181. 080601b, P.I. A2.N.1

The expression  $4^{\frac{1}{2}} \cdot 2^3$  is equal to

[A] 16      [B]  $8^{\frac{3}{2}}$       [C] 4      [D]  $4^{\frac{3}{2}}$

182. 080218b, P.I. A2.N.1

The expression  $\frac{3^{\frac{1}{3}}}{3^{-\frac{2}{3}}}$  is equivalent to

- [A]  $\sqrt{3}$  [B] 1 [C] 3 [D]  $\sqrt[3]{3}$

183. 010217b, P.I. A2.N.1

The value of  $(\frac{3^0}{2})^{-1}$  is

- [A] 9 [B] -9 [C]  $\frac{1}{9}$  [D]  $-\frac{1}{9}$

184. 060208b, P.I. A2.A.10

If  $x$  is a positive integer,  $4x^{\frac{1}{2}}$  is equivalent to

- [A]  $4\frac{1}{x}$  [B]  $4\sqrt{x}$  [C]  $\frac{2}{x}$  [D]  $2x$

185. 010413b, P.I. A2.A.10

The expression  $b^{\frac{3}{2}}$ ,  $b > 0$ , is equivalent to

- [A]  $(\sqrt[3]{b})^2$  [B]  $-(\sqrt{b})^3$   
[C]  $\frac{1}{(\sqrt{b})^3}$  [D]  $\frac{1}{(\sqrt[3]{b})^2}$

186. 060708b, P.I. A2.A.11

The volume of a soap bubble is represented by the equation  $V = 0.094\sqrt{A^3}$ , where  $A$  represents the surface area of the bubble. Which expression is also equivalent to  $V$ ?

- [A]  $0.094A^{\frac{2}{3}}$  [B]  $(0.094A^3)^{\frac{1}{2}}$   
[C]  $0.094A^{\frac{3}{2}}$  [D]  $0.094A^6$

187. 060419b, P.I. A2.A.11

The expression  $\sqrt[4]{16a^6b^4}$  is equivalent to

- [A]  $4a^2b$  [B]  $4a^{\frac{3}{2}}b$   
[C]  $2a^{\frac{3}{2}}b$  [D]  $2a^2b$

188. 010617b, P.I. A2.A.8

When simplified, the expression  $(\sqrt[3]{m^4})(m^{-\frac{1}{2}})$  is equivalent to

- [A]  $\sqrt[4]{m^3}$  [B]  $\sqrt[6]{m^5}$   
[C]  $\sqrt[5]{m^{-4}}$  [D]  $\sqrt[3]{m^{-2}}$

189. 080322b, P.I. A2.N.1

Find the value of  $(x+2)^0 + (x+1)^{-\frac{2}{3}}$  when  $x = 7$ .

190. 060602b, P.I. A2.A.8

If  $f(x) = x^{-\frac{3}{2}}$ , then  $f(\frac{1}{4})$  is equal to

- [A] 8 [B] -2 [C] -4 [D]  $-\frac{1}{8}$

191. 060516b

If  $(a^x)^{\frac{2}{3}} = \frac{1}{a^2}$ , what is the value of  $x$ ?

- [A] -1 [B] 1 [C] -3 [D] 2

192. 080325b

Meteorologists can determine how long a storm lasts by using the function

$t(d) = 0.07d^{\frac{3}{2}}$ , where  $d$  is the diameter of the storm, in miles, and  $t$  is the time, in hours. If the storm lasts 4.75 hours, find its diameter, to the nearest tenth of a mile.

## CHAPTER 6-2

### REGRESSION

193. 010730b, P.I. A2.S.7

The accompanying table shows the number of new cases reported by the Nassau and Suffolk County Police Crime Stoppers program for the years 2000 through 2002.

Year ( $x$ )	New Cases ( $y$ )
2000	457
2001	369
2002	353

If  $x = 1$  represents the year 2000, and  $y$  represents the number of new cases, find the equation of best fit using a power regression, rounding all values to the *nearest thousandth*. Using this equation, find the estimated number of new cases, to the *nearest whole number*, for the year 2007.

194. 010831b, P.I. A2.S.7

Water is draining from a tank maintained by the Yorkville Fire Department. Students measured the depth of the water in 15-second intervals and recorded the results in the accompanying table.

Time ( $x$ ) (in seconds)	Depth of Water ( $y$ ) (in feet)
15	11.8
30	9.9
45	8.2
60	6.3
75	5.9

Write the power regression equation for this set of data, rounding all values to the *nearest ten thousandth*. Using this equation, predict the depth of the water at 2 minutes, to the *nearest tenth of a foot*.

## CHAPTER 6-7

### BINOMIAL EXPANSIONS

195. 010820b, P.I. A2.A.36

What is the coefficient of the fifth term in the expansion of  $(x + 1)^8$ ?

[A] 28    [B] 8    [C] 70    [D] 56

196. 080208b, P.I. A2.A.36

What is the *last* term in the expansion of  $(x + 2y)^5$ ?

[A]  $y^5$     [B]  $32y^5$     [C]  $10y^5$     [D]  $2y^5$

197. 080412b, P.I. A2.A.36

What is the middle term in the expansion of  $(x + y)^4$ ?

[A]  $6x^2y^2$     [B]  $4x^2y^2$   
[C]  $2x^2y^2$     [D]  $x^2y^2$

198. 060619b, P.I. A2.A.36  
What is the fourth term in the expansion of  $(y-1)^7$ ?
- [A]  $-35y^3$                       [B]  $35y^4$   
[C]  $-35y^4$                       [D]  $35y^3$
199. 010726b, P.I. A2.A.36  
What is the fourth term in the expansion of  $(2x-y)^5$ ?
200. 060517b, P.I. A2.A.36  
What is the third term in the expansion of  $(\cos x + 3)^5$ ?
- [A]  $90\cos^2 x$                       [B]  $60\cos^3 x$   
[C]  $270\cos^2 x$                       [D]  $90\cos^3 x$

**BINOMIAL PROBABILITY**

201. 010302b, P.I. A2.S.15  
The probability that Kyla will score above a 90 on a mathematics test is  $\frac{4}{5}$ . What is the probability that she will score above a 90 on three of the four tests this quarter?
- [A]  $\frac{3}{4}\left(\frac{4}{5}\right)^3\left(\frac{1}{5}\right)^1$                       [B]  ${}_4C_3\left(\frac{4}{5}\right)^1\left(\frac{1}{5}\right)^3$   
[C]  ${}_4C_3\left(\frac{4}{5}\right)^3\left(\frac{1}{5}\right)^1$                       [D]  $\frac{3}{4}\left(\frac{4}{5}\right)^1\left(\frac{1}{5}\right)^3$
202. 010805b, P.I. A2.S.15  
Sean tells prospective clients that the probability of rain at the dive location is .2 each day. Which expression can be used to calculate the probability that it will rain on *exactly* 5 days of the 7 days at the dive location?
- [A]  ${}_7C_2(.5)(.7)$                       [B]  ${}_7C_5(.2)^5(.8)^2$   
[C]  ${}_7C_5(.2)^2(.8)^5$                       [D]  ${}_7C_5(.5)(.7)$
203. 060402b, P.I. A2.S.15  
The Hiking Club plans to go camping in a State park where the probability of rain on any given day is 0.7. Which expression can be used to find the probability that it will rain on *exactly* three of the seven days they are there?
- [A]  ${}_4C_3(0.4)^4(0.3)^3$                       [B]  ${}_7C_3(0.3)^3(0.7)^4$   
[C]  ${}_7C_3(0.7)^3(0.3)^4$                       [D]  ${}_4C_3(0.7)^3(0.7)^4$
204. 060702b, P.I. A2.S.15  
During a single day at radio station WMZH, the probability that a particular song is played is .38. Which expression represents the probability that this song will be played on *exactly* 5 days out of 7 days?
- [A]  ${}_7C_5(.38)^2(.62)^5$                       [B]  ${}_5C_2(.38)^5(.62)^2$   
[C]  ${}_7P_5(.38)^5(.62)^2$                       [D]  ${}_7C_5(.38)^5(.62)^2$
205. 080201b, P.I. A2.S.15  
Which fraction represents the probability of obtaining *exactly* eight heads in ten tosses of a fair coin?
- [A]  $\frac{64}{1,024}$                                       [B]  $\frac{90}{1,024}$   
[C]  $\frac{45}{1,024}$                                       [D]  $\frac{180}{1,024}$
206. 060122b, P.I. A2.S.15  
At a certain intersection, the light for eastbound traffic is red for 15 seconds, yellow for 5 seconds, and green for 30 seconds. Find, to the *nearest tenth*, the probability that out of the next eight eastbound cars that arrive randomly at the light, exactly three will be stopped by a red light.



207. 060223b, P.I. A2.S.15  
After studying a couple's family history, a doctor determines that the probability of any child born to this couple having a gene for disease  $X$  is 1 out of 4. If the couple has three children, what is the probability that *exactly* two of the children have the gene for disease  $X$ ?

208. 080723b, P.I. A2.S.15  
Mr. and Mrs. Doran have a genetic history such that the probability that a child being born to them with a certain trait is  $\frac{1}{8}$ . If they have four children, what is the probability that *exactly* three of their four children will have that trait?

209. 010524b, P.I. A2.S.15  
If the probability that it will rain on any given day this week is 60%, find the probability it will rain *exactly* 3 out of 7 days this week.

210. 080522b, P.I. A2.S.15  
The Coolidge family's favorite television channels are 3, 6, 7, 10, 11, and 13. If the Coolidge family selects a favorite channel at random to view each night, what is the probability that they choose *exactly* three even-numbered channels in five nights? Express your answer as a fraction or as a decimal rounded to *four decimal places*.

211. 010625b, P.I. A2.S.15  
During a recent survey, students at Franconia College were asked if they drink coffee in the morning. The results showed that two-thirds of the students drink coffee in the morning and the remainder do not. What is the probability that of six students selected at random, *exactly* two of them drink coffee in the morning? Express your answer as a fraction or as a decimal rounded to *four decimal places*.

212. 060625b, P.I. A2.S.15  
Ginger and Mary Anne are planning a vacation trip to the island of Capri, where the probability of rain on any day is 0.3. What is the probability that during their five days on the island, they have *no* rain on *exactly* three of the five days?

213. 080128b, P.I. A2.S.15  
As shown in the accompanying diagram, a circular target with a radius of 9 inches has a bull's-eye that has a radius of 3 inches. If five arrows randomly hit the target, what is the probability that *at least* four hit the bull's-eye?

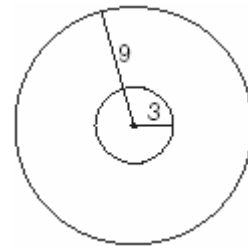

214. 010229b, P.I. A2.S.15  
Team  $A$  and team  $B$  are playing in a league. They will play each other five times. If the probability that team  $A$  wins a game is  $\frac{1}{3}$ , what is the probability that team  $A$  will win *at least* three of the five games?

215. 060331b, P.I. A2.S.15  
On any given day, the probability that the entire Watson family eats dinner together is  $\frac{2}{5}$ . Find the probability that, during any 7-day period, the Watsons eat dinner together *at least* six times.

216. 080430b, P.I. A2.S.15  
Tim Parker, a star baseball player, hits one home run for every ten times he is at bat. If Parker goes to bat five times during tonight's game, what is the probability that he will hit *at least* four home runs?

## MATH TOOLBOX P. 311

### REGRESSION

217. 060529b, P.I. A2.S.15  
The probability that a planted watermelon seed will sprout is  $\frac{3}{4}$ . If Peyton plants seven seeds from a slice of watermelon, find, to the *nearest ten thousandth*, the probability that *at least* five will sprout.
218. 080630b, P.I. A2.S.15  
On mornings when school is in session in January, Sara notices that her school bus is late one-third of the time. What is the probability that during a 5-day school week in January her bus will be late *at least* three times?
219. 010428b, P.I. A2.S.15  
A board game has a spinner on a circle that has five equal sectors, numbered 1, 2, 3, 4, and 5, respectively. If a player has four spins, find the probability that the player spins an even number *no more than* two times on those four spins.
220. 010731b, P.I. A2.S.15  
Dr. Glendon, the school physician in charge of giving sports physicals, has compiled his information and has determined that the probability a student will be on a team is 0.39. Yesterday, Dr. Glendon examined five students chosen at random. Find, to the *nearest hundredth*, the probability that at least four of the five students will be on a team. Find, to the *nearest hundredth*, the probability that exactly one of the five students will not be on a team.
221. 080334b, P.I. A2.S.15  
When Joe bowls, he can get a strike (knock down all the pins) 60% of the time. How many times more likely is it for Joe to bowl *at least* three strikes out of four tries as it is for him to bowl zero strikes out of four tries? Round your answer to the *nearest whole number*.

222. 080705a, P.I. A2.S.7  
The population growth of Boomtown is shown in the accompanying graph.

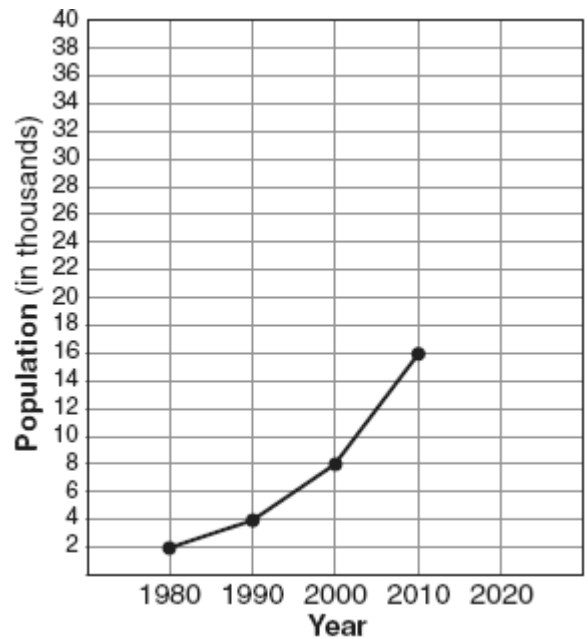

If the same pattern of population growth continues, what will the population of Boomtown be in the year 2020?

- [A] 20,000                      [B] 40,000  
[C] 64,000                      [D] 32,000

223. 080429b, P.I. A2.S.7

A box containing 1,000 coins is shaken, and the coins are emptied onto a table. Only the coins that land heads up are returned to the box, and then the process is repeated. The accompanying table shows the number of trials and the number of coins returned to the box after each trial.

Trial	0	1	3	4	6
Coins Returned	1,000	610	220	132	45

Write an exponential regression equation, rounding the calculated values to the *nearest ten-thousandth*. Use the equation to predict how many coins would be returned to the box after the eighth trial.

224. 060234b, P.I. A2.S.7

The table below, created in 1996, shows a history of transit fares from 1955 to 1995. On the accompanying grid, construct a scatter plot where the independent variable is years. State the exponential regression equation with the coefficient and base rounded to the *nearest thousandth*. Using this equation, determine the prediction that should have been made for the year 1998, to the *nearest cent*.

Year	Fare (\$)
55	0.10
60	0.15
65	0.20
70	0.30
75	0.40
80	0.60
85	0.80
90	1.15
95	1.50

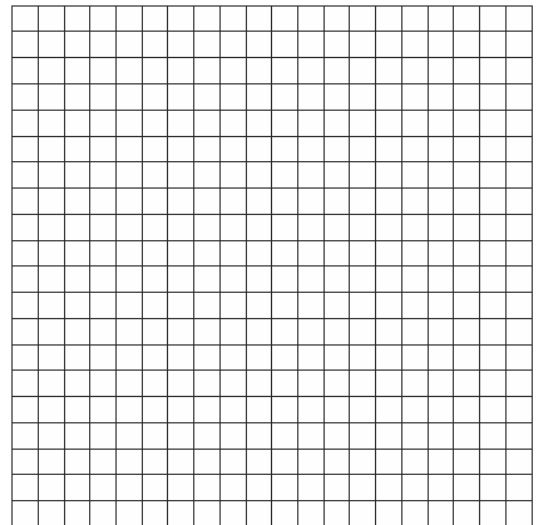

225. 080232b, P.I. A2.S.7

The breaking strength,  $y$ , in tons, of steel cable with diameter  $d$ , in inches, is given in the table below.

$d$ (in)	$y$ (tons)
0.50	9.85
0.75	21.80
1.00	38.30
1.25	59.20
1.50	84.40
1.75	114.00

On the accompanying grid, make a scatter plot of these data. Write the exponential regression equation, expressing the regression coefficients to the *nearest tenth*.

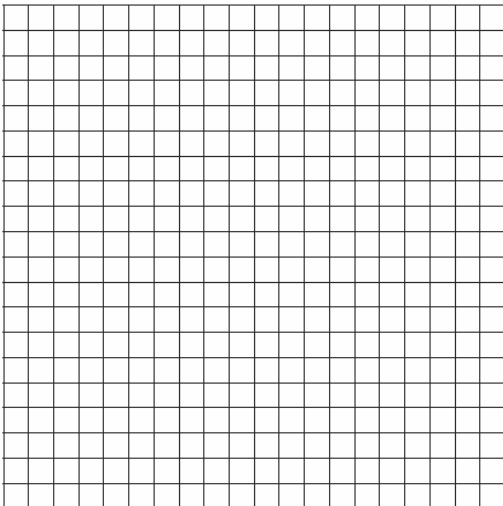

226. 010433b, P.I. A2.S.7

The accompanying table shows the average salary of baseball players since 1984. Using the data in the table, create a scatter plot on the grid and state the exponential regression equation with the coefficient and base rounded to the *nearest hundredth*. Using your written regression equation, estimate the salary of a baseball player in the year 2005, to the *nearest thousand dollars*.

Baseball Players' Salaries

Numbers of Years Since 1984	Average Salary (thousands of dollars)
0	290
1	320
2	400
3	495
4	600
5	700
6	820
7	1,000
8	1,250
9	1,580

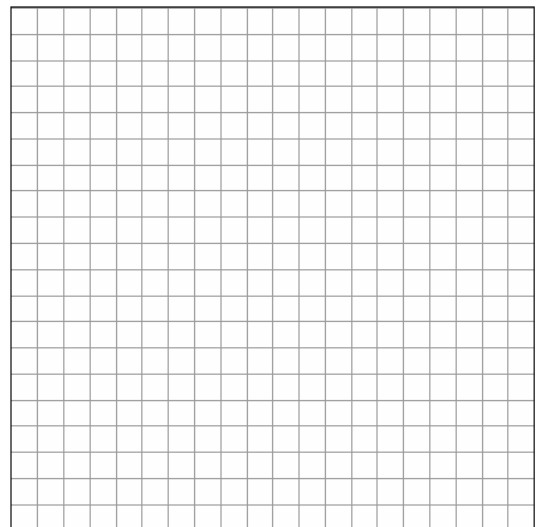

227. 080631b, P.I. A2.S.7  
Jean invested \$380 in stocks. Over the next 5 years, the value of her investment grew, as shown in the accompanying table.

Years Since Investment ( $x$ )	Value of Stock, in Dollars ( $y$ )
0	380
1	395
2	411
3	427
4	445
5	462

Write the exponential regression equation for this set of data, rounding all values to *two decimal places*. Using this equation, find the value of her stock, to the *nearest dollar*, 10 years after her initial purchase.

## CHAPTER 7-2

### EXPONENTIAL FUNCTIONS

228. 010813b  
A radioactive substance has an initial mass of 100 grams and its mass halves every 4 years. Which expression shows the number of grams remaining after  $t$  years?

[A]  $100(4)^{-2t}$       [B]  $100(4)^{\frac{t}{4}}$   
[C]  $100(\frac{1}{2})^{4t}$       [D]  $100(\frac{1}{2})^{\frac{t}{4}}$

229. 060721b, P.I. A.A.9  
A population of wolves in a county is represented by the equation  $P(t) = 80(0.98)^t$ , where  $t$  is the number of years since 1998. Predict the number of wolves in the population in the year 2008.

230. 060607b, P.I. A.A.9  
The height,  $f(x)$ , of a bouncing ball after  $x$  bounces is represented by  $f(x) = 80(0.5)^x$ . How many times higher is the first bounce than the fourth bounce?  
[A] 4      [B] 8      [C] 2      [D] 16
231. 010525b, P.I. A.A.9  
On January 1, 1999, the price of gasoline was \$1.39 per gallon. If the price of gasoline increased by 0.5% per month, what was the cost of one gallon of gasoline, to the *nearest cent*, on January 1 one year later?
232. fall0719ia, P.I. A.A.9  
Daniel's Print Shop purchased a new printer for \$35,000. Each year it depreciates (loses value) at a rate of 5%. What will its approximate value be at the end of the fourth year?  
[A] \$33,250.00      [B] \$27,082.33  
[C] \$28,507.72      [D] \$30,008.13
233. 080221b, P.I. A.A.9  
A used car was purchased in July 1999 for \$11,900. If the car depreciates 13% of its value each year, what is the value of the car, to the *nearest hundred dollars*, in July 2002?
234. 080224b, P.I. A.A.9  
The Franklins inherited \$3,500, which they want to invest for their child's future college expenses. If they invest it at 8.25% with interest compounded monthly, determine the value of the account, in dollars, after 5 years.  
Use the formula  $A = P(1 + \frac{r}{n})^{nt}$ , where  $A =$  value of the investment after  $t$  years,  $P =$  principal invested,  $r =$  annual interest rate, and  $n =$  number of times compounded per year.

**SOLVING NONLINEAR SYSTEMS**

235. 060519b

The graphs of the equations  $y = 2^x$  and  $y = -2x + a$  intersect in Quadrant I for which values of  $a$ ?

- [A]  $a > 1$                       [B]  $a \geq 1$   
[C]  $a < 1$                       [D]  $0 < a < 1$

236. 080705b

The flight paths of two Thunderbird jets are plotted on a Cartesian coordinate plane, and the equations of the jets' flight paths are represented by  $y = 2^x + 3$  and  $y = 0.5^x$ . The best approximation of the intersection of the flight paths is

- [A] (-1.50, 2.82)              [B] (0, 1)  
[C] (-1.72, 3.3)              [D] (-2, -1)

237. 010628b

On the accompanying grid, sketch the graphs of  $y = 2^x$  and  $3y = 7x + 3$  over the interval  $-3 \leq x \leq 4$ . Identify and state the coordinates of all points of intersection.

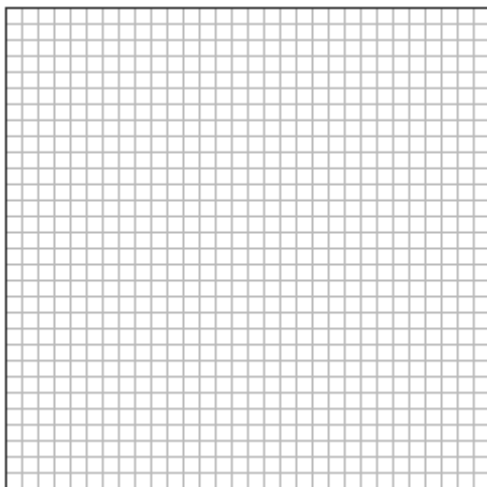

238. 010527b

On the accompanying grid, solve the following system of equations graphically:

$$y = -x^2 + 2x + 1$$
$$y = 2^x$$

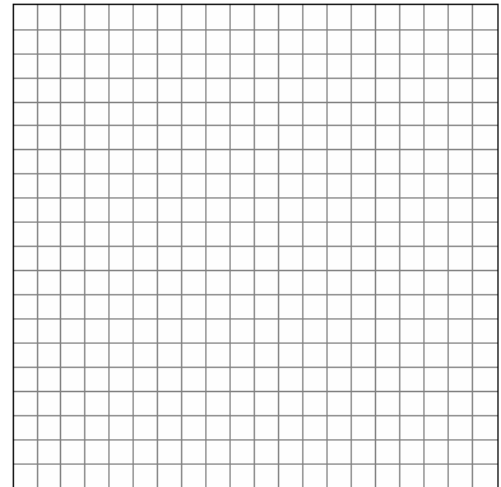

## CHAPTER 7-3

### GRAPHING LOGARITHMIC FUNCTIONS

239. 080530b, P.I. A2.A.28  
A hotel finds that its total annual revenue and the number of rooms occupied daily by guests can best be modeled by the function  $R = 3\log(n^2 + 10n)$ ,  $n > 0$ , where  $R$  is the total annual revenue, in millions of dollars, and  $n$  is the number of rooms occupied daily by guests. The hotel needs an annual revenue of \$12 million to be profitable. Graph the function on the accompanying grid over the interval  $0 < n \leq 100$ . Calculate the minimum number of rooms that must be occupied daily to be profitable.

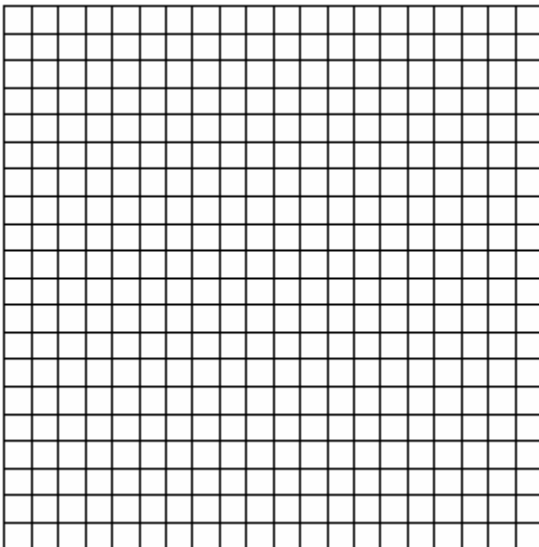

### PROPERTIES OF LOGARITHMS

240. 060409b, P.I. A2.A.19  
If  $\log_b x = y$ , then  $x$  equals

[A]  $y \cdot b$    [B]  $b^y$    [C]  $y^b$    [D]  $\frac{y}{b}$

241. 080607b, P.I. A2.A.19  
The function  $y = 2^x$  is equivalent to  
[A]  $y = x \log 2$    [B]  $x = \log_2 y$   
[C]  $y = \log_2 x$    [D]  $x = y \log 2$
242. 060301b  
For which value of  $x$  is  $y = \log x$  undefined?  
[A] 1483   [B] 0   [C]  $\frac{1}{10}$    [D]  $\pi$
243. 010412b  
The expression  $\log_3(8 - x)$  is defined for all values of  $x$  such that  
[A]  $x \leq 8$    [B]  $x \geq 8$   
[C]  $x > 8$    [D]  $x < 8$
244. 080110b, P.I. A2.A.19  
If  $\log 5 = a$ , then  $\log 250$  can be expressed as  
[A]  $50a$    [B]  $2a + 1$   
[C]  $25a$    [D]  $10 + 2a$
245. 010208b, P.I. A2.A.19  
Which expression is *not* equivalent to  $\log_b 36$ ?  
[A]  $\log_b 72 - \log_b 2$    [B]  $\log_b 9 + \log_b 4$   
[C]  $6\log_b 2$    [D]  $2\log_b 6$
246. 060316b, P.I. A2.A.19  
If  $\log a = 2$  and  $\log b = 3$ , what is the numerical value of  $\log \frac{\sqrt{a}}{b^3}$ ?  
[A] -8   [B] -25   [C] 25   [D] 8

247. 010409b, P.I. A2.A.19  
If  $\log x = a$ ,  $\log y = b$ , and  $\log z = c$ , then  $\log \frac{x^2y}{\sqrt{z}}$  is equivalent to

[A]  $2ab - \frac{1}{2}c$       [B]  $2a + b - \frac{1}{2}c$   
[C]  $a^2 + b - \frac{1}{2}c$       [D]  $42a + b + \frac{1}{2}c$

248. 010316b, P.I. A2.A.19  
The expression  $\log 10^{x+2} - \log 10^x$  is equivalent to

[A]  $\frac{1}{100}$     [B]  $-2$     [C]  $2$     [D]  $100$

249. 060510b, P.I. A2.A.19  
If  $\log a = x$  and  $\log b = y$ , what is  $\log a\sqrt{b}$ ?

[A]  $x + \frac{y}{2}$       [B]  $x + 2y$   
[C]  $\frac{x+y}{2}$       [D]  $2x + 2y$

250. 010611b, P.I. A2.A.19  
The speed of sound,  $v$ , at temperature  $T$ , in degrees Kelvin, is represented by the equation  $v = 1087\sqrt{\frac{T}{273}}$ . Which expression is equivalent to  $\log v$ ?

[A]  $1087 + \frac{1}{2}\log T - \log 273$   
[B]  $1087(\frac{1}{2}\log T - \frac{1}{2}\log 273)$   
[C]  $\log 1087 + \frac{1}{2}\log T - \frac{1}{2}\log 273$   
[D]  $\log 1087 + 2\log(T + 273)$

251. 080709b, P.I. A2.A.19  
The equation used to determine the time it takes a swinging pendulum to return to its starting point is  $T = 2\pi\sqrt{\frac{\ell}{g}}$ , where  $T$  represents time, in seconds,  $\ell$  represents the length of the pendulum, in feet, and  $g$  equals  $32 \text{ ft/sec}^2$ . How is this equation expressed in logarithmic form?

[A]  $\log T = \log 2 + \log \pi + \frac{1}{2}\log \ell - \frac{1}{2}\log 32$   
[B]  $\log T = 2 + \log \pi + \frac{1}{2}\log \ell - 16$   
[C]  $\log T = \log 2 + \log \pi + \frac{1}{2}\log \ell - \log 16$   
[D]  $\log T = \log 2 + \log \pi + \log \sqrt{\ell - 32}$

252. 010717b, P.I. A2.A.19  
A black hole is a region in space where objects seem to disappear. A formula used in the study of black holes is the Schwarzschild formula,  $R = \frac{2GM}{c^2}$ . Based on the laws of logarithms,  $\log R$  can be represented by
- [A]  $2\log G + \log M - \log 2c$   
[B]  $\log 2G + \log M - \log 2c$   
[C]  $2\log GM - 2\log c$   
[D]  $\log 2 + \log G + \log M - 2\log c$

## CHAPTER 7-4

### LOGARITHMIC EQUATIONS

253. 010519b, P.I. A2.A.28  
If  $\log_5 x = 2$ , what is the value of  $\sqrt{x}$ ?
- [A] 5      [B]  $2^{\frac{2}{5}}$       [C] 25      [D]  $\sqrt{5}$
254. 060623b, P.I. A2.A.28  
Solve for  $x$ :  $\log_2(x+1) = 3$



255. 010819b, P.I. A2.A.28  
If  $\log_x 9 = -2$ , what is the value of  $x$ ?
- [A] 81      [B]  $\frac{1}{81}$       [C]  $\frac{1}{3}$       [D] 3
256. 080212b, P.I. A2.A.19  
If  $\log k = c \log v + \log p$ ,  $k$  equals
- [A]  $v^c p$                       [B]  $cv + p$   
[C]  $(vp)^c$                       [D]  $v^c + p$
257. 080209b, P.I. A2.A.28  
In the equation  $\log_x 4 + \log_x 9 = 2$ ,  $x$  is equal to
- [A]  $\sqrt{13}$       [B] 6      [C] 18      [D] 6.5
258. 080624b, P.I. A2.A.28  
Solve for  $x$ :  $\log_b 36 - \log_b 2 = \log_b x$
259. 060230b, P.I. A2.A.28  
Solve for  $x$ :  $\log_4(x^2 + 3x) - \log_4(x + 5) = 1$
260. 080720b, P.I. A2.A.28  
If  $\log_2 a = \log_3 a$ , what is the value of  $a$ ?
- [A] 3      [B] 4      [C] 1      [D] 2
261. 010324b, P.I. A2.A.28  
The relationship between the relative size of an earthquake,  $S$ , and the measure of the earthquake on the Richter scale,  $R$ , is given by the equation  $\log S = R$ . If an earthquake measured 3.2 on the Richter scale, what was its relative size to the *nearest hundredth*?
262. 060102b, P.I. A2.A.28  
The magnitude ( $R$ ) of an earthquake is related to its intensity ( $I$ ) by  $R = \log\left(\frac{I}{T}\right)$ , where  $T$  is the threshold below which the earthquake is not noticed. If the intensity is doubled, its magnitude can be represented by
- [A]  $2(\log I - \log T)$       [B]  $2 \log I - \log T$   
[C]  $\log I - \log T$       [D]  $\log 2 + \log I - \log T$

263. 060125b, P.I. A2.A.18  
The scientists in a laboratory company raise amebas to sell to schools for use in biology classes. They know that one ameba divides into two amebas every hour and that the formula  $t = \log_2 N$  can be used to determine how long in hours,  $t$ , it takes to produce a certain number of amebas,  $N$ . Determine, to the *nearest tenth of an hour*, how long it takes to produce 10,000 amebas if they start with one ameba.

## CHAPTER 7-5

### EXPONENTIAL EQUATIONS

264. 060612b, P.I. A2.A.27  
The solution set of  $2^{x^2+2x} = 2^{-1}$  is
- [A] {1}      [B] {}      [C] {-1}      [D] {-1, 1}
265. 010709b, P.I. A2.A.27  
What is the value of  $b$  in the equation  $4^{2b-3} = 8^{1-b}$ ?
- [A]  $\frac{10}{7}$       [B]  $-\frac{3}{7}$       [C]  $\frac{7}{9}$       [D]  $\frac{9}{7}$
266. 010626b, P.I. A2.A.27  
Solve algebraically for  $x$ :  $8^{2x} = 4^6$
267. 060303b, P.I. A2.A.27  
What is the value of  $x$  in the equation  $81^{x+2} = 27^{5x+4}$ ?
- [A]  $\frac{4}{11}$       [B]  $-\frac{3}{2}$       [C]  $-\frac{4}{11}$       [D]  $-\frac{2}{11}$
268. 060422b, P.I. A2.A.27  
Solve algebraically for  $x$ :  $27^{2x+1} = 9^{4x}$
269. 060522b, P.I. A2.A.27  
Solve for  $m$ :  $3^{m+1} - 5 = 22$

270. 080118b, P.I. A2.A.27  
Determine the value of  $x$  and  $y$  if  $2^y = 8^x$  and  $3^y = 3^{x+4}$ .

- [A]  $x = 2, y = 6$       [B]  $x = 6, y = 2$   
[C]  $x = y$               [D]  $x = -2, y = -6$

271. 080502b, P.I. A2.A.27  
The growth of bacteria in a dish is modeled by the function  $f(t) = 2^{\frac{t}{3}}$ . For which value of  $t$  is  $f(t) = 32$ ?

- [A] 15      [B] 16      [C] 8      [D] 2

272. 060224b, P.I. A2.A.27  
Growth of a certain strain of bacteria is modeled by the equation  $G = A(2.7)^{0.584t}$ , where:  $G$  = final number of bacteria,  $A$  = initial number of bacteria,  $t$  = time (in hours). In approximately how many hours will 4 bacteria first increase to 2,500 bacteria? Round your answer to the *nearest hour*.

273. 010828b, P.I. A2.A.27  
The number of houses in Central Village, New York, grows every year according to the function  $H(t) = 540(1.039)^t$ , where  $H$  represents the number of houses, and  $t$  represents the number of years since January 1995. A civil engineering firm has suggested that a new, larger well must be built by the village to supply its water when the number of houses exceeds 1,000. During which year will this first happen?

274. 010728b, P.I. A2.A.27  
Since January 1980, the population of the city of Brownville has grown according to the mathematical model  $y = 720,500(1.022)^x$ , where  $x$  is the number of years since January 1980. Explain what the numbers 720,500 and 1.022 represent in this model. If this trend continues, use this model to predict the year during which the population of Brownville will reach 1,548,800. [The use of the grid is optional.]

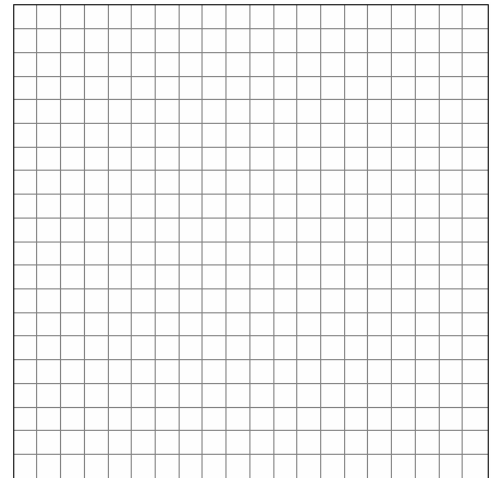

275. 080632b, P.I. A2.A.27

After an oven is turned on, its temperature,  $T$ , is represented by the equation

$T = 400 - 350(3.2)^{-0.1m}$  where  $m$  represents the number of minutes after the oven is turned on and  $T$  represents the temperature of the oven, in degrees Fahrenheit. How many minutes does it take for the oven's temperature to reach  $300^\circ\text{F}$ ? Round your answer to the *nearest minute*. [The use of the grid is optional.]

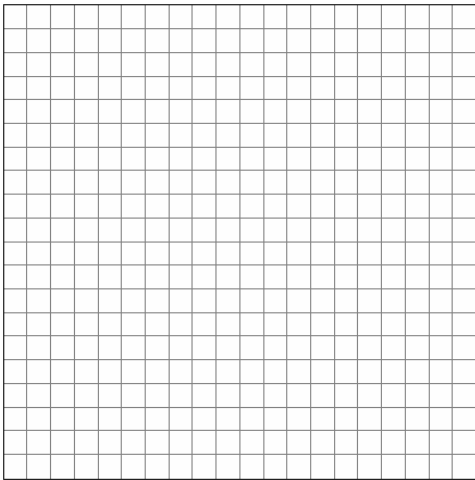

276. 080729b, P.I. A2.A.27

Drew's parents invested \$1,500 in an account such that the value of the investment doubles every seven years. The value of the investment,  $V$ , is determined by the equation

$V = 1500(2)^{\frac{t}{7}}$ , where  $t$  represents the number of years since the money was deposited. How many years, to the *nearest tenth of a year*, will it take the value of the investment to reach \$1,000,000?

277. 080428b, P.I. A2.A.27

An amount of  $P$  dollars is deposited in an account paying an annual interest rate  $r$  (as a decimal) compounded  $n$  times per year. After  $t$  years, the amount of money in the account, in dollars, is given by the equation

$$A = P\left(1 + \frac{r}{n}\right)^{nt}$$

Rachel deposited \$1,000 at 2.8% annual interest, compounded monthly. In how many years, to the *nearest tenth of a year*, will she have \$2,500 in the account? [The use of the grid is optional.]

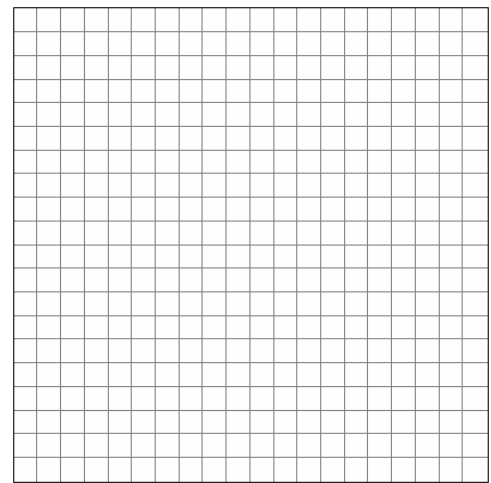

278. 010429b, P.I. A2.A.27

The equation for radioactive decay is

$p = (0.5)^{\frac{t}{H}}$ , where  $p$  is the part of a substance with half-life  $H$  remaining radioactive after a period of time,  $t$ . A given substance has a half-life of 6,000 years. After  $t$  years, one-fifth of the original sample remains radioactive. Find  $t$ , to the *nearest thousand years*.

279. 060431b, P.I. A2.A.27  
An archaeologist can determine the approximate age of certain ancient specimens by measuring the amount of carbon-14, a radioactive substance, contained in the specimen. The formula used to determine the age of a specimen is  $A = A_0 2^{\frac{-t}{5760}}$ , where  $A$  is the amount of carbon-14 that a specimen contains,  $A_0$  is the original amount of carbon-14,  $t$  is time, in years, and 5760 is the half-life of carbon-14. A specimen that originally contained 120 milligrams of carbon-14 now contains 100 milligrams of this substance. What is the age of the specimen, to the nearest hundred years?

280. 010230b, P.I. A2.A.27  
Depreciation (the decline in cash value) on a car can be determined by the formula  $V = C(1-r)^t$ , where  $V$  is the value of the car after  $t$  years,  $C$  is the original cost, and  $r$  is the rate of depreciation. If a car's cost, when new, is \$15,000, the rate of depreciation is 30%, and the value of the car now is \$3,000, how old is the car to the nearest tenth of a year?

281. 080132b, P.I. A2.A.27  
The amount  $A$ , in milligrams, of a 10-milligram dose of a drug remaining in the body after  $t$  hours is given by the formula  $A = 10(0.8)^t$ . Find, to the nearest tenth of an hour, how long it takes for half of the drug dose to be left in the body.

282. 010632b, P.I. A2.A.27  
The current population of Little Pond, New York, is 20,000. The population is decreasing, as represented by the formula  $P = A(1.3)^{-0.234t}$ , where  $P$  = final population,  $t$  = time, in years, and  $A$  = initial population. What will the population be 3 years from now? Round your answer to the nearest hundred people. To the nearest tenth of a year, how many years will it take for the population to reach half the present population? [The use of the grid is optional.]

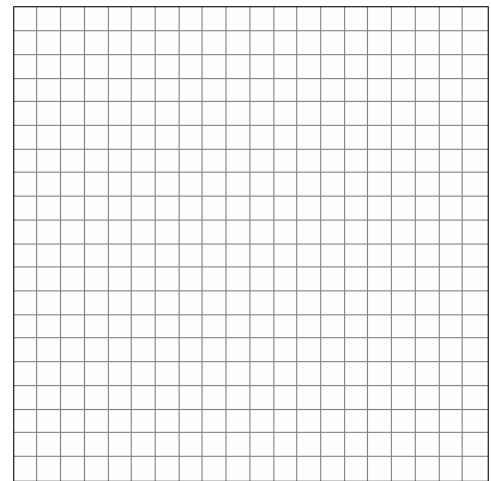

## CHAPTER 7-6

283. 060330b, P.I. A2.A.27  
Sean invests \$10,000 at an annual rate of 5% compounded continuously, according to the formula  $A = Pe^{rt}$ , where  $A$  is the amount,  $P$  is the principal,  $e = 2.718$ ,  $r$  is the rate of interest, and  $t$  is time, in years. Determine, to the nearest dollar, the amount of money he will have after 2 years. Determine how many years, to the nearest year, it will take for his initial investment to double.

## CHAPTER 8-1

### INVERSE VARIATION

284. 010221b  
Explain how a person can determine if a set of data represents inverse variation and give an example using a table of values.
285. 010503b  
If  $R$  varies inversely as  $S$ , when  $S$  is doubled,  $R$  is multiplied by
- [A] 2      [B]  $\frac{1}{4}$       [C] 4      [D]  $\frac{1}{2}$
286. 060508b  
In a given rectangle, the length varies inversely as the width. If the length is doubled, the width will
- [A] be divided by 2      [B] be multiplied by 2  
[C] remain the same  
[D] increase by 2
287. 080402b, P.I. A2.A.5  
The speed of a laundry truck varies inversely with the time it takes to reach its destination. If the truck takes 3 hours to reach its destination traveling at a constant speed of 50 miles per hour, how long will it take to reach the same location when it travels at a constant speed of 60 miles per hour?
- [A]  $2\frac{1}{2}$  hours      [B]  $2\frac{2}{3}$  hours  
[C]  $2\frac{1}{3}$  hours      [D] 2 hours
288. 010624b, P.I. A2.A.5  
The time it takes to travel to a location varies inversely to the speed traveled. It takes 4 hours driving at an average speed of 55 miles per hour to reach a location. To the *nearest tenth of an hour*, how long will it take to reach the same location driving at an average speed of 50 miles per hour?
289. 060323b, P.I. A2.A.5  
When air is pumped into an automobile tire, the pressure is inversely proportional to the volume. If the pressure is 35 pounds when the volume is 120 cubic inches, what is the pressure, in pounds, when the volume is 140 cubic inches?
290. 080523b, P.I. A2.A.5  
Boyle's Law states that the pressure of compressed gas is inversely proportional to its volume. The pressure of a certain sample of a gas is 16 kilopascals when its volume is 1,800 liters. What is the pressure, in kilopascals, when its volume is 900 liters?
291. 060618b, P.I. A2.A.5  
According to Boyle's Law, the pressure,  $p$ , of a compressed gas is inversely proportional to the volume,  $v$ . If a pressure of 20 pounds per square inch exists when the volume of the gas is 500 cubic inches, what is the pressure when the gas is compressed to 400 cubic inches?
- [A] 25 lb/in<sup>2</sup>      [B] 50 lb/in<sup>2</sup>  
[C] 16 lb/in<sup>2</sup>      [D] 40 lb/in<sup>2</sup>
292. 010823b, P.I. A2.A.5  
The amount of money each member of a band earns playing at a graduation party varies inversely as the number of members in the band. If the band has five members, each member earns \$70. Write an equation that models the relationship between the number of members in a band,  $n$ , and the amount each member earns,  $d$ . Use the equation to calculate the amount each member earns if there are four members in the band.
293. 080123b, P.I. A2.A.5  
The price per person to rent a limousine for a prom varies inversely as the number of passengers. If five people rent the limousine, the cost is \$70 each. How many people are renting the limousine when the cost *per couple* is \$87.50?

294. 080207b, P.I. A2.A.5  
To balance a seesaw, the distance, in feet, a person is from the fulcrum is inversely proportional to the person's weight, in pounds. Bill, who weighs 150 pounds, is sitting 4 feet away from the fulcrum. If Dan weighs 120 pounds, how far from the fulcrum should he sit to balance the seesaw?

[A] 3.5 ft [B] 3 ft [C] 4.5 ft [D] 5 ft

295. 010423b, P.I. A2.A.5  
A pulley that has a diameter of 8 inches is belted to a pulley that has a diameter of 12 inches. The 8-inch-diameter pulley is running at 1,548 revolutions per minute. If the speeds of the pulleys vary inversely to their diameters, how many revolutions per minute does the larger pulley make?

## CHAPTER 8-3

### SOLVING NONLINEAR SYSTEMS

296. 010704b  
What is the total number of points of intersection of the graphs of the equations  $xy = 12$  and  $y = -x^2 + 3$ ?

[A] 2 [B] 3 [C] 4 [D] 1

## MATH TOOLBOX P. 375

### RATIONALIZING DENOMINATORS

297. 060305b, P.I. A2.N.5  
Which expression is equivalent to  $\frac{4}{3+\sqrt{2}}$ ?

[A]  $\frac{12-4\sqrt{2}}{7}$  [B]  $\frac{12-4\sqrt{2}}{11}$   
[C]  $\frac{12+4\sqrt{2}}{7}$  [D]  $\frac{12+4\sqrt{2}}{11}$

298. 080606b, P.I. A2.N.5  
The expression  $\frac{12}{3+\sqrt{3}}$  is equivalent to

[A]  $4-2\sqrt{3}$  [B]  $2+\sqrt{3}$   
[C]  $12-\sqrt{3}$  [D]  $6-2\sqrt{3}$

299. 080716b, P.I. A2.N.5  
The expression  $\frac{2}{1-\sqrt{3}}$  is equivalent to

[A]  $1+\sqrt{3}$  [B]  $-1-\sqrt{3}$   
[C]  $1-\sqrt{3}$  [D]  $-1+\sqrt{3}$

300. 010405b, P.I. A2.N.5  
The expression  $\frac{7}{2-\sqrt{3}}$  is equivalent to

[A]  $\frac{14+\sqrt{3}}{7}$  [B]  $\frac{2+\sqrt{3}}{7}$   
[C]  $14-7\sqrt{3}$  [D]  $14+7\sqrt{3}$

301. 010516b, P.I. A2.N.5  
The expression  $\frac{7}{3-\sqrt{2}}$  is equivalent to

[A]  $\frac{21+\sqrt{2}}{7}$  [B]  $3+\sqrt{2}$   
[C]  $\frac{3+\sqrt{2}}{7}$  [D]  $3-\sqrt{2}$

302. 080506b, P.I. A2.N.5  
The expression  $\frac{1}{5-\sqrt{13}}$  is equivalent to

[A]  $\frac{5+\sqrt{13}}{-8}$  [B]  $\frac{5+\sqrt{13}}{8}$   
[C]  $\frac{5+\sqrt{13}}{-12}$  [D]  $\frac{5+\sqrt{13}}{12}$

303. 010708b, P.I. A2.N.5

The expression  $\frac{4}{5-\sqrt{13}}$  is equivalent to

- [A]  $\frac{5-\sqrt{13}}{3}$                       [B]  $\frac{5+\sqrt{13}}{3}$   
[C]  $\frac{2(5-\sqrt{13})}{19}$                 [D]  $\frac{2(5+\sqrt{13})}{19}$

304. 080420b, P.I. A2.N.5

The expression  $\frac{11}{\sqrt{3}-5}$  is equivalent to

- [A]  $\frac{\sqrt{3}+5}{2}$                               [B]  $\frac{-\sqrt{3}+5}{2}$   
[C]  $\frac{-\sqrt{3}-5}{2}$                               [D]  $\frac{\sqrt{3}-5}{2}$

305. 010613b, P.I. A2.N.5

The expression  $\frac{5}{\sqrt{5}-1}$  is equivalent to

- [A]  $\frac{5}{4}$                                       [B]  $\frac{5\sqrt{5}-5}{6}$   
[C]  $\frac{5\sqrt{5}-5}{4}$                               [D]  $\frac{5\sqrt{5}+5}{4}$

306. 060709b, P.I. A2.N.5

The fraction  $\frac{3}{\sqrt{6}-1}$  is equivalent to

- [A]  $3\sqrt{6}+3$                           [B]  $3\sqrt{6}-3$   
[C]  $\frac{3\sqrt{6}-3}{5}$                               [D]  $\frac{3\sqrt{6}+3}{5}$

307. 080307b, P.I. A2.N.5

Which expression is equal to  $\frac{2+\sqrt{3}}{2-\sqrt{3}}$ ?

- [A]  $7+4\sqrt{3}$                       [B]  $\frac{7+4\sqrt{3}}{7}$   
[C]  $1-4\sqrt{3}$                       [D]  $\frac{1-4\sqrt{3}}{7}$

308. 080210b, P.I. A2.N.5

Which expression represents the sum of  $\frac{1}{\sqrt{3}} + \frac{1}{\sqrt{2}}$ ?

- [A]  $\frac{2\sqrt{3}+3\sqrt{2}}{6}$                       [B]  $\frac{2}{\sqrt{5}}$   
[C]  $\frac{\sqrt{3}+\sqrt{2}}{3}$                               [D]  $\frac{\sqrt{3}+\sqrt{2}}{2}$

## CHAPTER 8-4

### RATIONAL EXPRESSIONS

309. 060712b, P.I. A.A.16

Which expression is in simplest form?

- [A]  $\frac{9}{x^2+9}$                               [B]  $\frac{x^2-6x+9}{x^2-x-6}$   
[C]  $\frac{x}{x^2}$                                 [D]  $\frac{x^2-4}{x+2}$

310. 080305b, P.I. A.A.16

Written in simplest form, the expression  $\frac{x^2y^2-9}{3-xy}$  is equivalent to

- [A]  $-1$                                   [B]  $3+xy$   
[C]  $\frac{1}{3+xy}$                               [D]  $-(3+xy)$

311. 060504b, P.I. A.A.16

Written in simplest form, the expression

$\frac{x^2 - 9x}{45x - 5x^2}$  is equivalent to

- [A]  $\frac{1}{5}$  [B]  $-\frac{1}{5}$  [C]  $-5$  [D]  $5$

312. 080619b, P.I. A.A.16

The expression  $\frac{3y^2 - 12y}{4y^2 - y^3}$  is equivalent to

- [A]  $\frac{3}{4} - \frac{12}{y^2}$  [B]  $\frac{3}{y}$  [C]  $-\frac{3}{y}$  [D]  $-\frac{9}{4}$

313. 060325b

Express the following rational expression in

simplest form:  $\frac{9 - x^2}{10x^2 - 28x - 6}$

314. 060202b, P.I. A.A.16

For all values of  $x$  for which the expression is

defined,  $\frac{2x + x^2}{x^2 + 5x + 6}$  is equivalent to

- [A]  $\frac{1}{x+2}$  [B]  $\frac{x}{x+3}$   
[C]  $\frac{1}{x+3}$  [D]  $\frac{x}{x+2}$

### COMPLEX FRACTIONS

315. 010206b, P.I. A2.A.17

The expression  $\frac{\frac{a}{b} - \frac{b}{a}}{\frac{1}{a} + \frac{1}{b}}$  is equivalent to

- [A]  $a - b$  [B]  $a + b$   
[C]  $ab$  [D]  $\frac{a - b}{ab}$

316. 010312b, P.I. A2.A.17

The fraction  $\frac{\frac{x}{y} + x}{\frac{1}{y} + 1}$  is equivalent to

- [A]  $2x$  [B]  $x$  [C]  $\frac{2xy}{1+y}$  [D]  $\frac{x^2y}{1+y}$

317. 080706b, P.I. A2.A.17

Which expression is equivalent to the

complex fraction  $\frac{\frac{1}{1-a}}{\frac{a}{\frac{1}{a} + 1}}$ ?

- [A]  $-(1-a)$  [B]  $-1$   
[C]  $1-a$  [D]  $+1$

318. 060317b, P.I. A2.A.17

In simplest form,  $\frac{\frac{1}{x^2} - \frac{1}{y^2}}{\frac{1}{y} + \frac{1}{x}}$  is equal to

- [A]  $x - y$  [B]  $y - x$   
[C]  $\frac{x - y}{xy}$  [D]  $\frac{y - x}{xy}$

319. 010706b, P.I. A2.A.17

The expression  $\frac{\frac{1}{x} + \frac{1}{3x}}{\frac{1}{x} + \frac{1}{3}}$  is equivalent to

- [A]  $2$  [B]  $\frac{3x+3}{x+3}$  [C]  $\frac{1}{3}$  [D]  $\frac{x+1}{x+3}$

320. 060713b, P.I. A2.A.17

The expression  $\frac{\frac{1}{3} - \frac{1}{x}}{\frac{3}{x} - 1}$  is equivalent to

- [A]  $-\frac{1}{3}$  [B]  $\frac{1}{3}$  [C]  $-3$  [D]  $3$



321. 080323b, P.I. A2.A.17

Express in simplest form:  $\frac{\frac{x}{4} - \frac{4}{x}}{1 - \frac{4}{x}}$

322. 060415b, P.I. A2.A.17

The expression  $\frac{\frac{1}{x} + \frac{1}{y}}{\frac{1}{x^2} - \frac{1}{y^2}}$  is equivalent to

- [A]  $y - x$                       [B]  $\frac{xy}{y - x}$   
[C]  $\frac{y - x}{xy}$                       [D]  $\frac{xy}{x - y}$

323. 080220b, P.I. A2.A.17

Which expression is equivalent to the

complex fraction  $\frac{\frac{x}{x+2}}{1 - \frac{x}{x+2}}$ ?

- [A]  $\frac{2x}{x+2}$     [B]  $\frac{x}{2}$     [C]  $\frac{2}{x}$     [D]  $\frac{2x}{x^2+4}$

324. 080513b, P.I. A2.A.17

When simplified, the complex fraction

$\frac{1 + \frac{1}{\frac{x}{1-x}}}{\frac{1}{x}}$ ,  $x \neq 0$ , is equivalent to

- [A]  $\frac{1}{x-1}$     [B]  $-1$     [C]  $\frac{1}{1-x}$     [D]  $1$

325. 080425b, P.I. A2.A.17

Express in simplest form:  $\frac{\frac{1}{r} - \frac{1}{s}}{\frac{r}{r^2} - 1}$

326. 010629b, P.I. A2.A.17

Simplify completely:  $\frac{1-m}{m - \frac{1}{m}}$

327. 010826b, P.I. A2.A.17

Express in simplest form:  $\frac{x - \frac{4}{x}}{2 + x}$

328. 060628b, P.I. A2.A.17

Simplify for all values of  $a$  for which the

expression is defined:  $1 - \frac{2}{\frac{4}{a^2} - 1}$

329. 060112b, P.I. A2.A.17

In a science experiment, when resistor  $A$  and resistor  $B$  are connected in a parallel circuit, the total resistance is  $\frac{1}{\frac{1}{A} + \frac{1}{B}}$ . This complex fraction is equivalent to

- [A]  $\frac{AB}{A+B}$     [B]  $A+B$     [C]  $AB$     [D]  $1$

**MULTIPLICATION AND DIVISION OF RATIONALS**

330. 060124b, P.I. A.A.18

A rectangular prism has a length of  $\frac{2x^2 + 2x - 24}{4x^2 + x}$ , a width of  $\frac{x^2 + x - 6}{x + 4}$ , and a height of  $\frac{8x^2 + 2x}{x^2 - 9}$ . For all values of  $x$  for which it is defined, express, in terms of  $x$ , the volume of the prism in simplest form.

331. 080117b, P.I. A.A.18  
If the length of a rectangular garden is represented by  $\frac{x^2 + 2x}{x^2 + 2x - 15}$  and its width is represented by  $\frac{2x - 6}{2x + 4}$ , which expression represents the area of the garden?

[A]  $\frac{x}{x+5}$                       [B]  $x$   
[C]  $\frac{x^2 + 2x}{2(x+5)}$                 [D]  $x + 5$

332. 060727b, P.I. A2.A.16  
If  $f(x) = \frac{3x^2 - 27}{18x + 30}$  and  $g(x) = \frac{x^2 - 7x + 12}{3x^2 - 7x - 20}$ , find  $f(x) \div g(x)$  for all values of  $x$  for which the expression is defined and express your answer in simplest form.

333. 010434b, P.I. A.A.18  
Express in simplest form:  
 $\frac{4x+8}{x+1} \cdot \frac{2-x}{3x-15} \div \frac{x^2-4}{2x^2-8x-10}$

334. 010733b, P.I. A.A.18  
Perform the indicated operations and simplify completely:  
 $\frac{x^2-9}{x^2-5x} \cdot \frac{5x-x^2}{x^2-x-12} \div \frac{x-4}{x^2-8x+16}$

## CHAPTER 8-5

### ADDITION AND SUBTRACTION OF RATIONALS

335. 060524b, P.I. A2.A.16  
Express in simplest form:  $\frac{1}{x} + \frac{1}{x+3}$

336. 010315b, P.I. A2.A.16  
What is the sum of  $\frac{3}{x-3}$  and  $\frac{x}{3-x}$ ?  
[A] -1    [B]  $\frac{x+3}{x-3}$     [C] 0    [D] 1

337. 080505b, P.I. A2.A.16  
What is the sum of  $(y-5) + \frac{3}{y+2}$ ?  
[A]  $y-5$                       [B]  $\frac{y^2-7}{y+2}$   
[C]  $\frac{y-2}{y+2}$                       [D]  $\frac{y^2-3y-7}{y+2}$

338. 080733b, P.I. A2.A.16  
Express in simplest form:  
 $\frac{2x}{x^2-4} \div \frac{4}{x^2-4x+4} + \frac{12}{x^2-4} \cdot \frac{2-x}{3}$

## CHAPTER 8-6

### SOLVING RATIONALS

339. 080722b, P.I. A.A.26  
Solve for all values of  $x$ :  $\frac{2}{x+1} = x$
340. 080529b, P.I. A2.A.23  
Solve for all values of  $x$ :  $\frac{9}{x} + \frac{9}{x-2} = 12$

341. 060429b, P.I. A2.A.23  
Solve for  $x$  and express your answer in simplest radical form:  $\frac{4}{x} - \frac{3}{x+1} = 7$

342. 060212b, P.I. A2.A.23  
What is the solution set of the equation  $\frac{x}{x-4} - \frac{1}{x+3} = \frac{28}{x^2-x-12}$ ?  
[A] {4}    [B] {4,-6}    [C] {-6}    [D] { }

343. 010224b, P.I. A2.A.23

A rectangle is said to have a golden ratio

when  $\frac{w}{h} = \frac{h}{w-h}$ , where  $w$  represents width

and  $h$  represents height. When  $w = 3$ ,  
between which two consecutive integers will  
 $h$  lie?

344. 080125b, P.I. A2.A.23

Working by herself, Mary requires 16  
minutes more than Antoine to solve a  
mathematics problem. Working together,  
Mary and Antoine can solve the problem in 6  
minutes. If this situation is represented by the  
equation  $\frac{6}{t} + \frac{6}{t+16} = 1$ , where  $t$  represents the  
number of minutes Antoine works alone to  
solve the problem, how many minutes will it  
take Antoine to solve the problem if he works  
by himself?

345. 080234b, P.I. A2.A.23

Electrical circuits can be connected in series,  
one after another, or in parallel circuits that  
branch off a main line. If circuits are hooked  
up in parallel, the reciprocal of the total  
resistance in the series is found by adding the  
reciprocals of each resistance, as shown in the  
accompanying diagram.

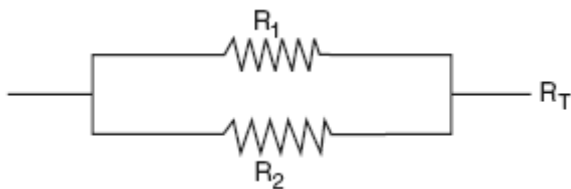

$$\frac{1}{R_1} + \frac{1}{R_2} = \frac{1}{R_T}$$

If  $R_1 = x$ ,  $R_2 = x + 3$ , and the total resistance,  
 $R_T$ , is 2.25 ohms, find the positive value of  
 $R_1$  to the nearest tenth of an ohm.

## CHAPTER 9-2

### UNIT CIRCLE

346. 080417b

Which angle is coterminal with an angle of  
 $125^\circ$ ?

- [A]  $-235^\circ$                       [B]  $235^\circ$   
[C]  $425^\circ$                         [D]  $-125^\circ$

347. 060503b, P.I. A2.A.57

Expressed as a function of a positive acute  
angle,  $\sin(-230^\circ)$  is equal to

- [A]  $\sin 50^\circ$                       [B]  $-\sin 50^\circ$   
[C]  $\cos 50^\circ$                     [D]  $-\cos 50^\circ$

348. 010818b, P.I. A2.A.57

The expression  $\cos(\pi - x)$  is equivalent to

- [A]  $\cos x$                          [B]  $-\cos x$   
[C]  $-\sin x$                       [D]  $\sin x$

349. 010205b, P.I. A2.A.56

If  $\theta$  is an angle in standard position and its  
terminal side passes through the point

$(\frac{1}{2}, \frac{\sqrt{3}}{2})$  on a unit circle, a possible value of  
 $\theta$  is

- [A]  $120^\circ$     [B]  $60^\circ$     [C]  $30^\circ$     [D]  $150^\circ$

350. 010422b, P.I. A2.A.62

In the accompanying diagram, point  $P(0.6, -0.8)$  is on unit circle  $O$ . What is the value of  $\theta$ , to the nearest degree?

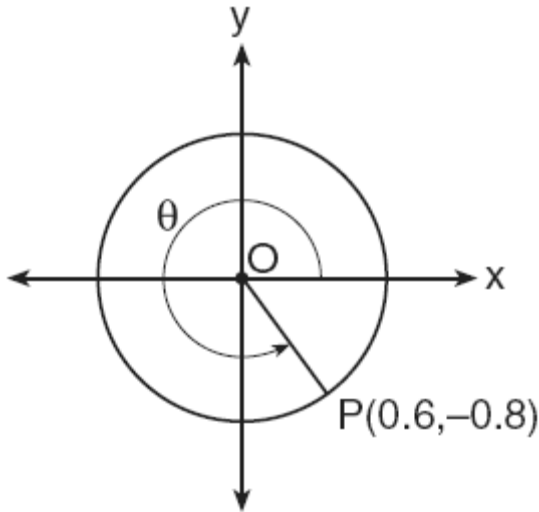

351. 080510b, P.I. A2.A.62

In the accompanying diagram of a unit circle, the ordered pair  $(-\frac{\sqrt{3}}{2}, -\frac{1}{2})$  represents the point where the terminal side of  $\theta$  intersects the unit circle.

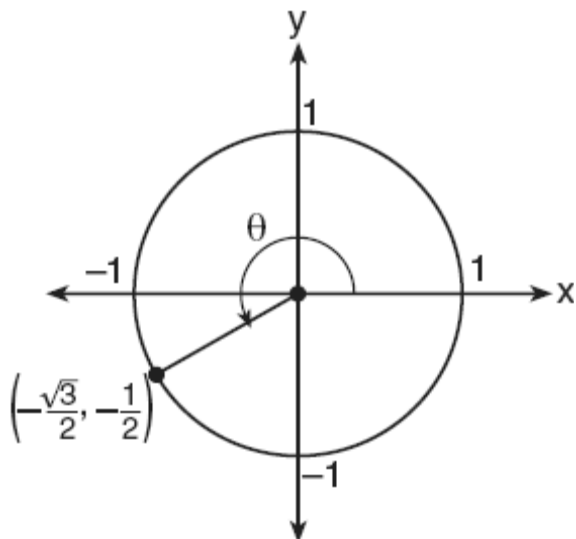

What is  $m\angle\theta$ ?

- [A] 233 [B] 225 [C] 240 [D] 210

352. 010718b

In the unit circle shown in the accompanying diagram, what are the coordinates of  $(x, y)$ ?

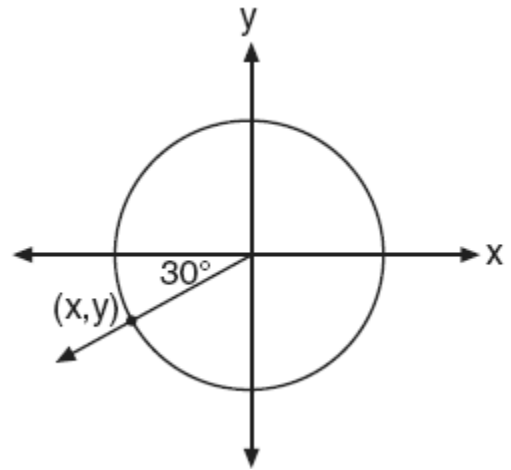

[A]  $(-\frac{\sqrt{3}}{2}, -0.5)$

[B]  $(-30, -210)$

[C]  $(-0.5, -\frac{\sqrt{3}}{2})$

[D]  $(-\frac{\sqrt{2}}{2}, -\frac{\sqrt{2}}{2})$

353. 080121b, P.I. A2.A.67

If the sine of an angle is  $\frac{3}{5}$  and the angle is not in Quadrant I, what is the value of the cosine of the angle?

354. 060520b

In the accompanying diagram,  $\overline{PR}$  is tangent to circle  $O$  at  $R$ ,  $\overline{QS} \perp \overline{OR}$ , and  $\overline{PR} \perp \overline{OR}$ .

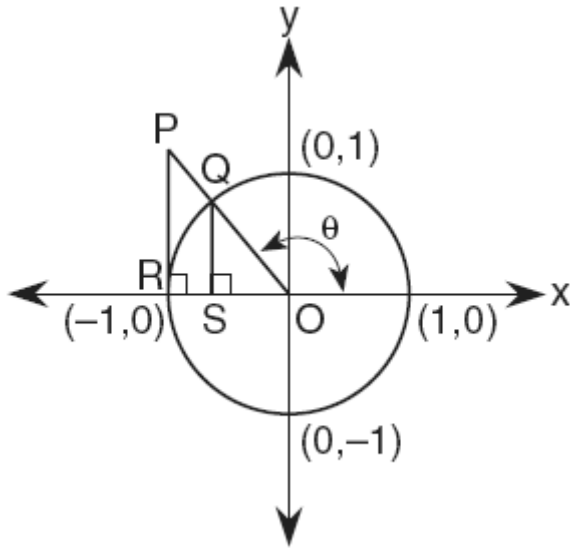

Which measure represents  $\sin \theta$ ?

- [A] RO [B] QS [C] PR [D] SO

355. 080604b, P.I. A2.A.67

If  $x$  is a positive acute angle and  $\cos x = \frac{\sqrt{3}}{4}$ ,  
what is the exact value of  $\sin x$ ?

- [A]  $\frac{3}{5}$  [B]  $\frac{\sqrt{13}}{4}$  [C]  $\frac{4}{5}$  [D]  $\frac{\sqrt{3}}{5}$

356. 080618b

The accompanying diagram shows unit circle  $O$ , with radius  $OB = 1$ .

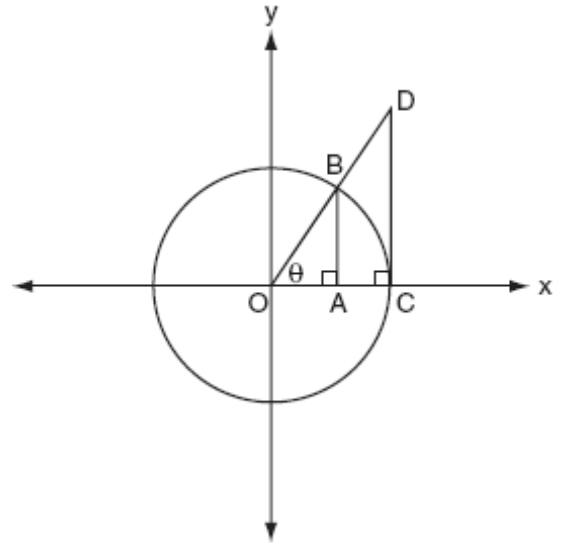

Which line segment has a length equivalent to  $\cos \theta$ ?

- [A]  $\overline{OC}$  [B]  $\overline{AB}$  [C]  $\overline{CD}$  [D]  $\overline{OA}$

357. 080511b

Two straight roads intersect at an angle whose measure is  $125^\circ$ . Which expression is equivalent to the cosine of this angle?

- [A]  $-\cos 55^\circ$  [B]  $-\cos 35^\circ$   
[C]  $\cos 55^\circ$  [D]  $\cos 35^\circ$

358. 010616b, P.I. A2.A.62

If  $\theta$  is an angle in standard position and  $P(-3,4)$  is a point on the terminal side of  $\theta$ , what is the value of  $\sin \theta$ ?

- [A]  $\frac{4}{5}$  [B]  $-\frac{3}{5}$  [C]  $-\frac{4}{5}$  [D]  $\frac{3}{5}$

359. 060302b, P.I. A2.A.58

If  $\sin \theta > 0$  and  $\sec \theta < 0$ , in which quadrant does the terminal side of angle  $\theta$  lie?

- [A] IV [B] II [C] III [D] I

360. 080410b, P.I. A2.A.58  
If the tangent of an angle is negative and its secant is positive, in which quadrant does the angle terminate?  
[A] III [B] IV [C] II [D] I
361. 060502b  
If  $\sin \theta$  is negative and  $\cos \theta$  is negative, in which quadrant does the terminal side of  $\theta$  lie?  
[A] IV [B] III [C] II [D] I
362. 060609b, P.I. A2.A.58  
If  $\tan \theta = 2.7$  and  $\csc \theta < 0$ , in which quadrant does  $\theta$  lie?  
[A] IV [B] III [C] II [D] I
363. 060118b  
If  $\theta$  is an obtuse angle and  $\sin \theta = b$ , then it can be concluded that  
[A]  $\cos 2\theta > b$  [B]  $\sin 2\theta < b$   
[C]  $\cos \theta > b$  [D]  $\tan \theta > b$
364. 060222b, P.I. A2.A.66  
Is  $\frac{1}{2} \sin 2x$  the same expression as  $\sin x$ ?  
Justify your answer.
367. 060120b  
Through how many radians does the minute hand of a clock turn in 24 minutes?  
[A]  $0.6\pi$  [B]  $0.2\pi$   
[C]  $0.4\pi$  [D]  $0.8\pi$
368. 010615b  
What is the radian measure of the angle formed by the hands of a clock at 2:00 p.m.?  
[A]  $\frac{\pi}{2}$  [B]  $\frac{\pi}{4}$  [C]  $\frac{\pi}{6}$  [D]  $\frac{\pi}{3}$
369. 080223b  
An art student wants to make a string collage by connecting six equally spaced points on the circumference of a circle to its center with string. What would be the radian measure of the angle between two adjacent pieces of string, in simplest form?
370. 010421b  
Kristine is riding in car 4 of the Ferris wheel represented in the accompanying diagram. The Ferris wheel is rotating in the direction indicated by the arrows. The eight cars are equally spaced around the circular wheel. Express, in radians, the measure of the *smallest* angle through which she will travel to reach the bottom of the Ferris wheel.

## CHAPTER 9-3

### RADIAN MEASURE

365. 080623b, P.I. A2.M.2  
What is the number of degrees in an angle whose radian measure is  $\frac{7\pi}{12}$ ?
366. 080704b, P.I. A2.M.2  
What is  $235^\circ$ , expressed in radian measure?  
[A]  $\frac{\pi}{235}$  [B]  $\frac{47\pi}{36}$   
[C]  $235\pi$  [D]  $\frac{36\pi}{47}$

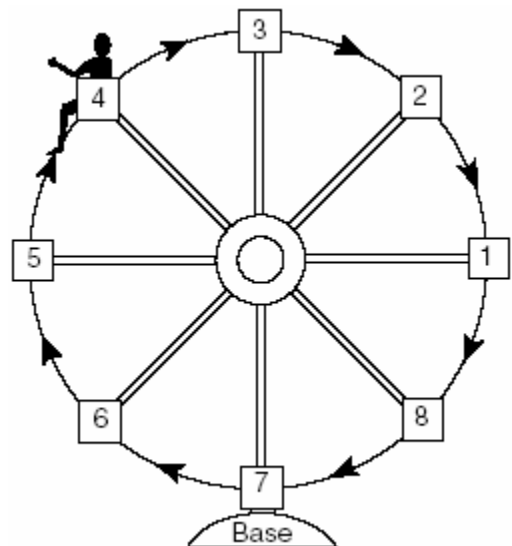

371. 010725b

As shown in the accompanying diagram, a dial in the shape of a semicircle has a radius of 4 centimeters. Find the measure of  $\theta$ , in radians, when the pointer rotates to form an arc whose length is 1.38 centimeters.

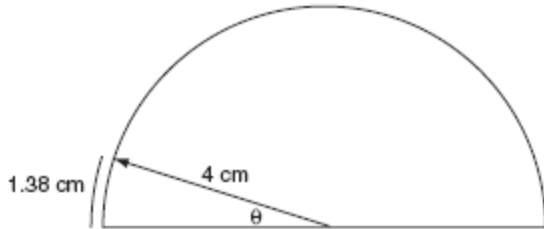

372. 080116b

A wedge-shaped piece is cut from a circular pizza. The radius of the pizza is 6 inches. The rounded edge of the crust of the piece measures 4.2 inches. To the *nearest tenth*, the angle of the pointed end of the piece of pizza, in radians, is

- [A] 1.4    [B] 0.7    [C] 7.0    [D] 25.2

373. 080309b

A dog has a 20-foot leash attached to the corner where a garage and a fence meet, as shown in the accompanying diagram. When the dog pulls the leash tight and walks from the fence to the garage, the arc the leash makes is 55.8 feet.

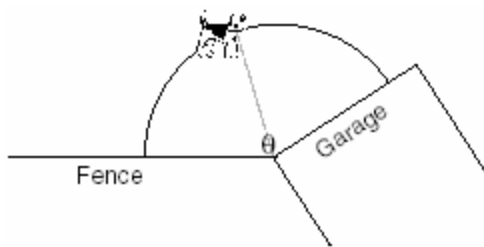

(Not drawn to scale)

What is the measure of angle  $\theta$  between the garage and the fence, in radians?

- [A] 160    [B] 3.14    [C] 2.79    [D] 0.36

374. 060531b, P.I. A2.A.61

Kathy and Tami are at point  $A$  on a circular track that has a radius of 150 feet, as shown in the accompanying diagram. They run counterclockwise along the track from  $A$  to  $S$ , a distance of 247 feet. Find, to the *nearest degree*, the measure of minor arc  $AS$ .

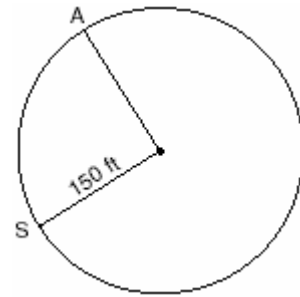

375. 010526b, P.I. A2.A.56

An arc of a circle that is 6 centimeters in length intercepts a central angle of 1.5 radians. Find the number of centimeters in the radius of the circle.

376. 060626b

The pendulum of a clock swings through an angle of 2.5 radians as its tip travels through an arc of 50 centimeters. Find the length of the pendulum, in centimeters.

377. 010307b

Ileana buys a large circular pizza that is divided into eight equal slices. She measures along the outer edge of the crust from one piece and finds it to be  $5\frac{1}{2}$  inches. What is the diameter of the pizza to the *nearest inch*?

- [A] 7    [B] 4    [C] 14    [D] 8

378. 010806b

Jack wants to plant a border of flowers in the shape of an arc along the edge of a circular walkway. If the circle has a radius of 5 yards and the angle subtended by the arc measures  $1\frac{1}{2}$  radians, what is the length, in yards, of the border?

- [A] 2      [B] 7.5      [C] 5      [D] 0.5

379. 080109b

A regular hexagon is inscribed in a circle. What is the ratio of the length of a side of the hexagon to the minor arc that it intercepts?

- [A]  $\frac{3}{6}$       [B]  $\frac{3}{\pi}$       [C]  $\frac{6}{\pi}$       [D]  $\frac{\pi}{6}$

380. 010223b, P.I. A2.A.61

A ball is rolling in a circular path that has a radius of 10 inches, as shown in the accompanying diagram. What distance has the ball rolled when the subtended arc is  $54^\circ$ ? Express your answer to the *nearest hundredth of an inch*.

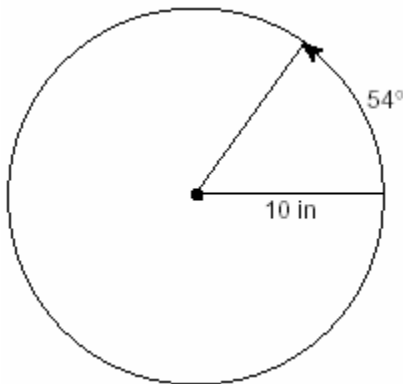

381. 080426b, P.I. A2.A.61

Cities  $H$  and  $K$  are located on the same line of longitude and the difference in the latitude of these cities is  $9^\circ$ , as shown in the accompanying diagram. If Earth's radius is 3,954 miles, how many miles north of city  $K$  is city  $H$  along arc  $HK$ ? Round your answer to the *nearest tenth of a mile*.

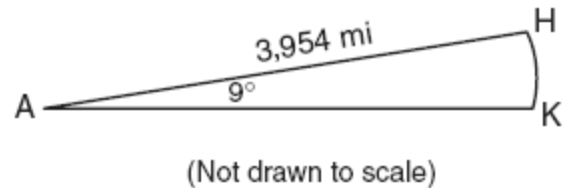

382. 080524b, P.I. A2.A.61

The accompanying diagram shows the path of a cart traveling on a circular track of radius 2.40 meters. The cart starts at point  $A$  and stops at point  $B$ , moving in a counterclockwise direction. What is the length of minor arc  $AB$ , over which the cart traveled, to the *nearest tenth of a meter*?

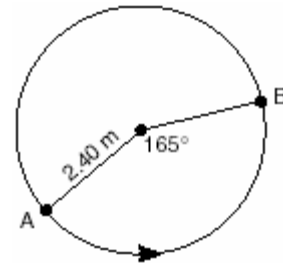

## CHAPTER 9-4

### TRIGONOMETRIC GRAPHS

383. 080113b, P.I. A2.A.69

What is the period of the function  $y = 5 \sin 3x$ ?

- [A]  $\frac{2\pi}{3}$       [B]  $\frac{2\pi}{5}$       [C] 3      [D] 5



384. 080615b, P.I. A2.A.69  
What is the period of the graph of the equation  $y = 2 \sin \frac{1}{3}x$ ?
- [A]  $6\pi$  [B]  $\frac{2}{3}\pi$  [C]  $\frac{3\pi}{2}$  [D]  $2\pi$
385. 010810b, P.I. A2.A.69  
A wave displayed by an oscilloscope is represented by the equation  $y = 3 \sin x$ . What is the period of this function?
- [A]  $3\pi$  [B]  $2\pi$  [C] 2 [D] 3
386. 010606b, P.I. A2.A.69  
A sound wave is modeled by the curve  $y = 3 \sin 4x$ . What is the period of this curve?
- [A] 4 [B]  $\pi$  [C]  $\frac{\pi}{2}$  [D] 3
387. 080514b, P.I. A2.A.69  
A certain radio wave travels in a path represented by the equation  $y = 5 \sin 2x$ . What is the period of this wave?
- [A]  $\pi$  [B]  $2\pi$  [C] 5 [D] 2
388. 060105b, P.I. A2.A.69  
A modulated laser heats a diamond. Its variable temperature, in degrees Celsius, is given by  $f(t) = T \sin at$ . What is the period of the curve?
- [A]  $|T|$  [B]  $\frac{2a\pi}{a}$  [C]  $\frac{1}{a}$  [D]  $\frac{2\pi}{a}$
389. 010425b, P.I. A2.A.69  
The brightness of the star MIRA over time is given by the equation  $y = 2 \sin \frac{\pi}{4}x + 6$ , where  $x$  represents time and  $y$  represents brightness. What is the period of this function, in radian measure?

390. 010204b, P.I. A2.A.69  
An object that weighs 2 pounds is suspended in a liquid. When the object is depressed 3 feet from its equilibrium point, it will oscillate according to the formula  $x = 3 \cos(8t)$ , where  $t$  is the number of seconds after the object is released. How many seconds are in the period of oscillation?
- [A]  $2\pi$  [B]  $\pi$  [C]  $\frac{\pi}{4}$  [D] 3
391. 010715b, P.I. A2.A.69  
What is the amplitude of the function shown in the accompanying graph?

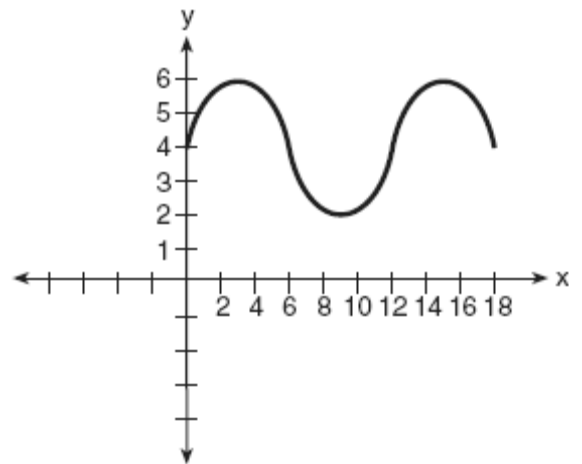

- [A] 2 [B] 12 [C] 1.5 [D] 6
392. 060403b, P.I. A2.A.69  
What is the amplitude of the function  $y = \frac{2}{3} \sin 4x$ ?
- [A]  $\frac{2}{3}$  [B] 4 [C]  $3\pi$  [D]  $\frac{\pi}{2}$
393. 010301b, P.I. A2.A.69  
A monitor displays the graph  $y = 3 \sin 5x$ . What will be the amplitude after a dilation of 2?
- [A] 5 [B] 7 [C] 6 [D] 10

394. 080419b

The path traveled by a roller coaster is modeled by the equation  $y = 27 \sin 13x + 30$ . What is the maximum altitude of the roller coaster?

- [A] 57 [B] 30 [C] 27 [D] 13

395. 010502b

The shaded portion of the accompanying map indicates areas of night, and the unshaded portion indicates areas of daylight at a particular moment in time.

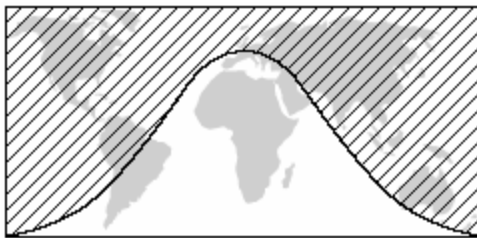

Which type of function best represents the curve that divides the area of night from the area of daylight?

- [A] tangent [B] cosine  
[C] logarithmic [D] quadratic

396. 010711b

Which transformation could be used to make the graph of the equation  $y = \sin x$  coincide with the graph of the equation  $y = \cos x$ ?

- [A] point reflection [B] translation  
[C] dilation [D] rotation

397. 080503b

The graphs below show the average annual precipitation received at different latitudes on Earth. Which graph is a translated cosine curve?

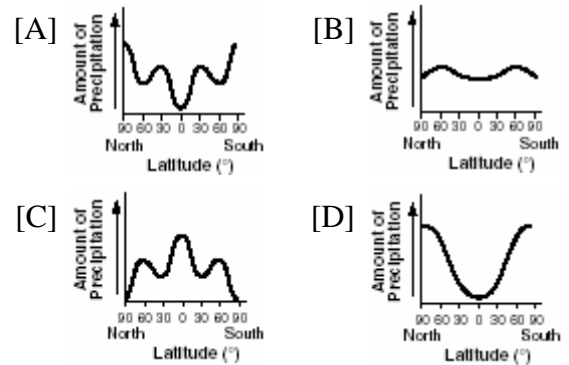

398. 010216b

Which type of symmetry does the equation  $y = \cos x$  have?

- [A] point symmetry with respect to  $(\frac{\pi}{2}, 0)$   
[B] line symmetry with respect to  $y = x$   
[C] point symmetry with respect to the origin  
[D] line symmetry with respect to the  $x$ -axis

399. 060711b, P.I. A2.A.72

Which equation is represented by the accompanying graph?

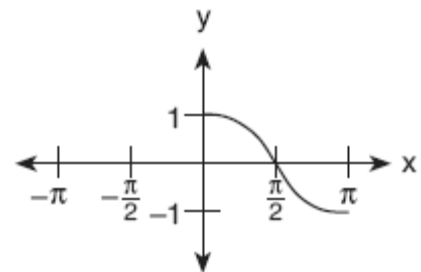

- [A]  $y = \cos x$  [B]  $y = \cos 2x$   
[C]  $y = \frac{1}{2} \cos x$  [D]  $y = \cos \frac{1}{2} x$

400. 080717b, P.I. A2.A.72

The accompanying graph represents a portion of a sound wave.

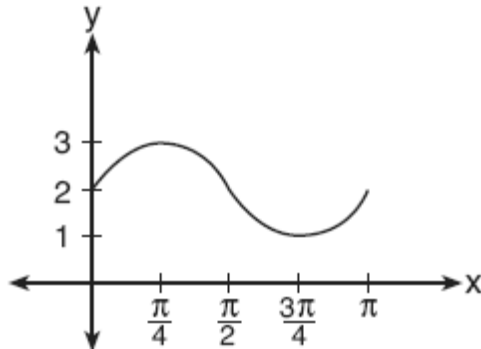

Which equation best represents this graph?

[A]  $y = \sin 2x + 2$       [B]  $y = \sin \frac{1}{2}x + 2$

[C]  $y = \sin 2x$       [D]  $y = 2 \sin \frac{1}{2}x$

401. 010612b, P.I. A2.A.72

In physics class, Eva noticed the pattern shown in the accompanying diagram on an oscilloscope.

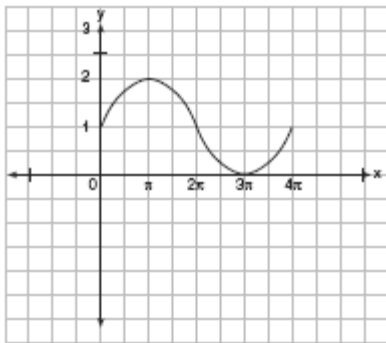

Which equation best represents the pattern shown on this oscilloscope?

[A]  $y = \sin\left(\frac{1}{2}x\right) + 1$

[B]  $y = 2 \sin x + 1$       [C]  $y = \sin x + 1$

[D]  $y = 2 \sin\left(-\frac{1}{2}x\right) + 1$

402. 060608b, P.I. A2.A.72

A radio transmitter sends a radio wave from the top of a 50-foot tower. The wave is represented by the accompanying graph.

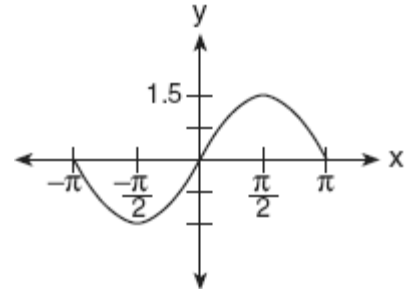

What is the equation of this radio wave?

[A]  $y = 1.5 \sin x$       [B]  $y = \sin 1.5x$

[C]  $y = \sin x$       [D]  $y = 2 \sin x$

403. 010214b, P.I. A2.A.72

The accompanying diagram shows a section of a sound wave as displayed on an oscilloscope.

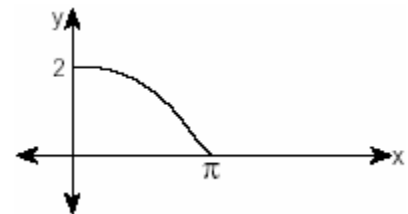

Which equation could represent this graph?

[A]  $y = 2 \sin \frac{x}{2}$       [B]  $y = 2 \cos \frac{x}{2}$

[C]  $y = \frac{1}{2} \sin \frac{\pi}{2}x$       [D]  $y = \frac{1}{2} \cos 2x$

404. 080330b, P.I. A2.A.72

A student attaches one end of a rope to a wall at a fixed point 3 feet above the ground, as shown in the accompanying diagram, and moves the other end of the rope up and down, producing a wave described by the equation  $y = a \sin bx + c$ . The range of the rope's height above the ground is between 1 and 5 feet. The period of the wave is  $4\pi$ . Write the equation that represents this wave.



405. 080127b

The times of average monthly sunrise, as shown in the accompanying diagram, over the course of a 12-month interval can be modeled by the equation  $y = A \cos(Bx) + D$ . Determine the values of  $A$ ,  $B$ , and  $D$ , and explain how you arrived at your values.

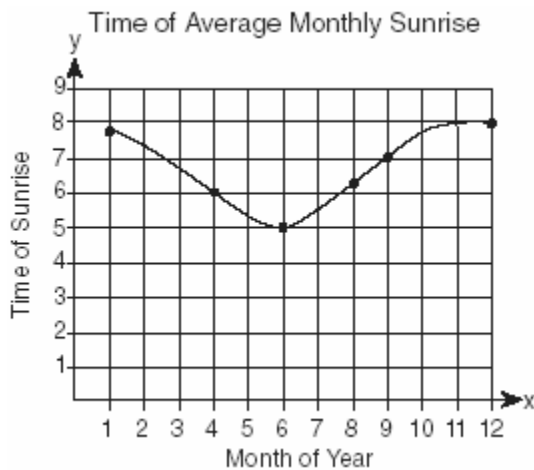

## CHAPTER 9-5

### TRIGONOMETRIC INEQUALITIES

406. 010329b

A building's temperature,  $T$ , varies with time of day,  $t$ , during the course of 1 day, as follows:  $T = 8 \cos t + 78$ . The air-conditioning operates when  $T \geq 80^\circ F$ . Graph this function for  $6 \leq t < 17$  and determine, to the nearest tenth of an hour, the amount of time in 1 day that the air-conditioning is on in the building.

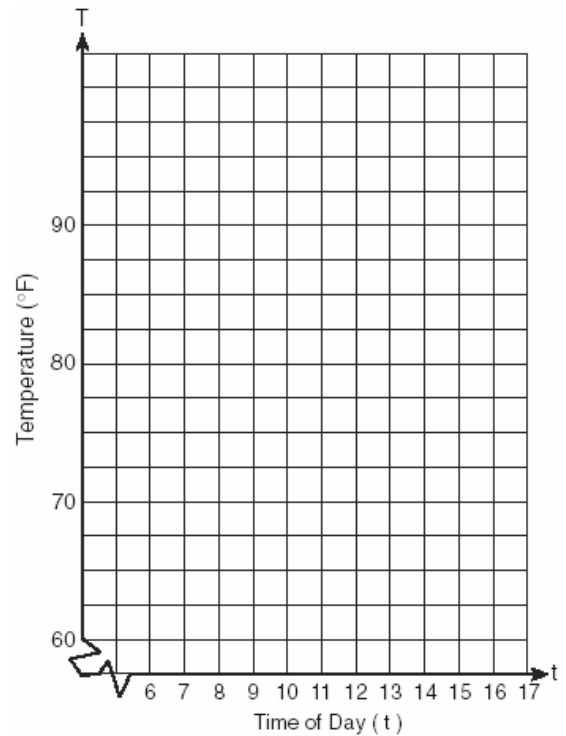

407. 080433b

The tide at a boat dock can be modeled by the equation  $y = -2 \cos\left(\frac{\pi}{6}t\right) + 8$ , where  $t$  is the number of hours past noon and  $y$  is the height of the tide, in feet. For how many hours between  $t = 0$  and  $t = 12$  is the tide at least 7 feet? [The use of the grid is optional.]

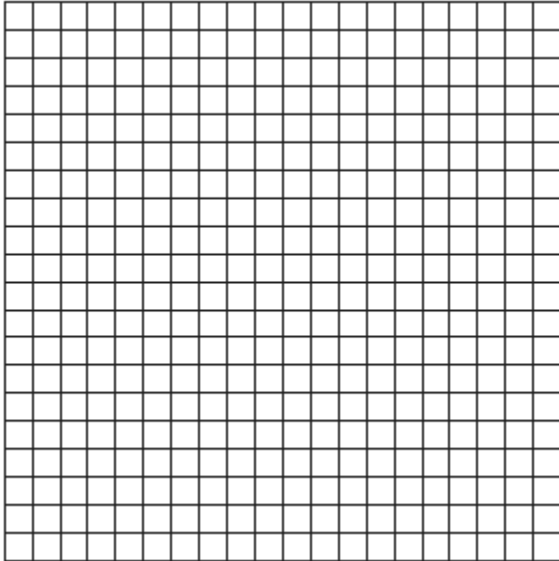

408. 080532b, P.I. A2.A.70

On the accompanying set of axes, graph the equations  $y = 4 \cos x$  and  $y = 2$  in the domain  $-\pi \leq x \leq \pi$ . Express, in terms of  $\pi$ , the interval for which  $4 \cos x \geq 2$ .

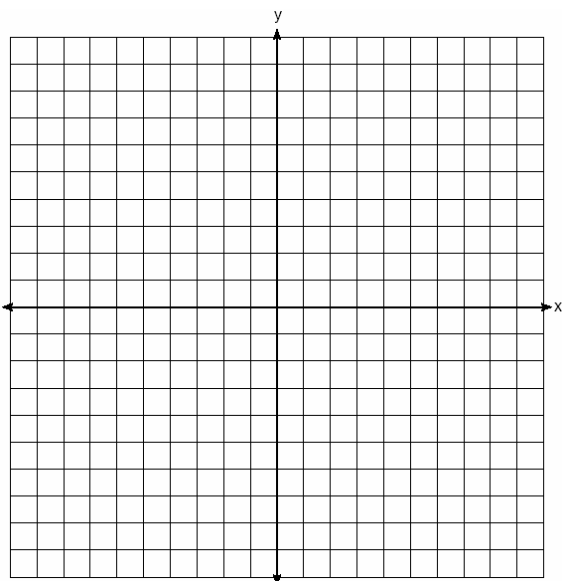

**SOLVING NONLINEAR SYSTEMS**

409. 060329b

A pair of figure skaters graphed part of their routine on a grid. The male skater's path is represented by the equation  $m(x) = 3 \sin \frac{1}{2}x$ , and the female skater's path is represented by the equation  $f(x) = -2 \cos x$ . On the accompanying grid, sketch both paths and state how many times the paths of the skaters intersect between  $x = 0$  and  $x = 4\pi$ .

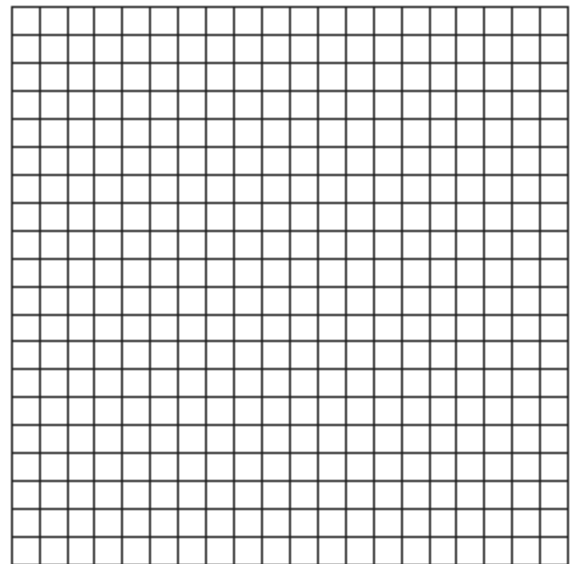

410. 060233b

On a monitor, the graphs of two impulses are recorded on the same screen, where  $0^\circ \leq x < 360^\circ$ . The impulses are given by the following equations:

$$y = 2 \sin^2 x$$

$$y = 1 - \sin x$$

Find all values of  $x$ , in degrees, for which the two impulses meet in the interval  $0^\circ \leq x < 360^\circ$ . [Only an algebraic solution will be accepted.]

## CHAPTER 9-7

### LAW OF COSINES

411. 010227b, P.I. A2.A.73

Two straight roads, Elm Street and Pine Street, intersect creating a  $40^\circ$  angle, as shown in the accompanying diagram. John's house ( $J$ ) is on Elm Street and is 3.2 miles from the point of intersection. Mary's house ( $M$ ) is on Pine Street and is 5.6 miles from the intersection. Find, to the *nearest tenth of a mile*, the direct distance between the two houses.

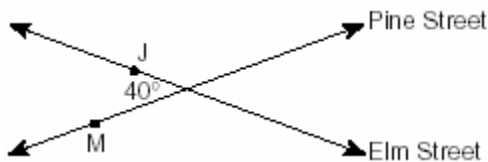

412. 080329b, P.I. A2.A.73

A ship at sea is 70 miles from one radio transmitter and 130 miles from another. The angle between the signals sent to the ship by the transmitters is  $117.4^\circ$ . Find the distance between the two transmitters, to the *nearest mile*.

413. 010528b, P.I. A2.A.73

To measure the distance through a mountain for a proposed tunnel, surveyors chose points  $A$  and  $B$  at each end of the proposed tunnel and a point  $C$  near the mountain. They determined that  $AC = 3,800$  meters,  $BC = 2,900$  meters, and  $m\angle ACB = 110$ . Draw a diagram to illustrate this situation and find the length of the tunnel, to the *nearest meter*.

414. 060127b, P.I. A2.A.73

A wooden frame is to be constructed in the form of an isosceles trapezoid, with diagonals acting as braces to strengthen the frame. The sides of the frame each measure 5.30 feet, and the longer base measures 12.70 feet. If the angles between the sides and the longer base each measure  $68.4^\circ$ , find the length of one brace to the *nearest tenth of a foot*.

415. 060232b, P.I. A2.A.73

Kieran is traveling from city  $A$  to city  $B$ . As the accompanying map indicates, Kieran could drive directly from  $A$  to  $B$  along County Route 21 at an average speed of 55 miles per hour or travel on the interstates, 45 miles along I-85 and 20 miles along I-64. The two interstates intersect at an angle of  $150^\circ$  at  $C$  and have a speed limit of 65 miles per hour. How much time will Kieran save by traveling along the interstates at an average speed of 65 miles per hour?

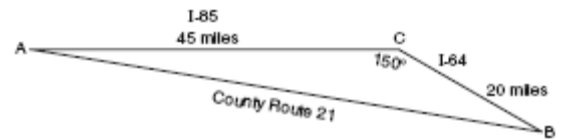

416. 060434b, P.I. A2.A.73

A surveyor is mapping a triangular plot of land. He measures two of the sides and the angle formed by these two sides and finds that the lengths are 400 yards and 200 yards and the included angle is  $50^\circ$ . What is the measure of the third side of the plot of land, to the *nearest yard*? What is the area of this plot of land, to the *nearest square yard*?

**LAW OF SINES**

417. 010702b, P.I. A2.A.73  
The accompanying diagram shows the approximate linear distances traveled by a sailboat during a race. The sailboat started at point  $S$ , traveled to points  $E$  and  $A$ , respectively, and ended at point  $S$ .

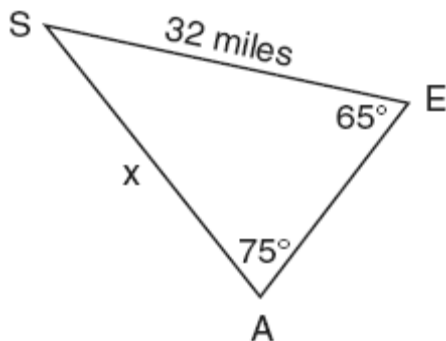

Based on the measures shown in the diagram, which equation can be used to find  $x$ , the distance from point  $A$  to point  $S$ ?

- [A]  $\frac{65}{x} = \frac{32}{75}$       [B]  $\frac{\sin 65^\circ}{x} = \frac{\sin 75^\circ}{32}$   
 [C]  $\frac{x}{\sin 65^\circ} = \frac{\sin 75^\circ}{32}$       [D]  $\frac{x}{65} = \frac{32}{75}$
418. 010407b, P.I. A2.A.73  
In  $\triangle ABC$ ,  $a = 19$ ,  $c = 10$ , and  $m\angle A = 111$ . Which statement can be used to find the value of  $\angle C$ ?
- [A]  $\sin C = \frac{19 \sin 69^\circ}{10}$   
 [B]  $\sin C = \frac{10 \sin 69^\circ}{19}$   
 [C]  $\sin C = \frac{10 \sin 21^\circ}{19}$       [D]  $\sin C = \frac{10}{19}$
419. 060622b, P.I. A2.A.73  
In  $\triangle ABC$ ,  $m\angle A = 53$ ,  $m\angle B = 14$ , and  $a = 10$ . Find  $b$  to the nearest integer.

420. 010212b, P.I. A2.A.73  
In  $\triangle ABC$ ,  $m\angle A = 33$ ,  $a = 12$ , and  $b = 15$ . What is  $m\angle B$  to the nearest degree?  
 [A] 41      [B] 43      [C] 48      [D] 44

421. 080421b, P.I. A2.A.73  
A ski lift begins at ground level 0.75 mile from the base of a mountain whose face has a  $50^\circ$  angle of elevation, as shown in the accompanying diagram. The ski lift ascends in a straight line at an angle of  $20^\circ$ . Find the length of the ski lift from the beginning of the ski lift to the top of the mountain, to the nearest hundredth of a mile.

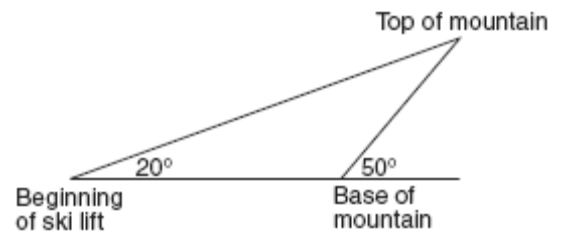

422. 080214b, P.I. A2.A.73  
In the accompanying diagram of  $\triangle ABC$ ,  $m\angle A = 30$ ,  $m\angle C = 50$ , and  $AC = 13$ .

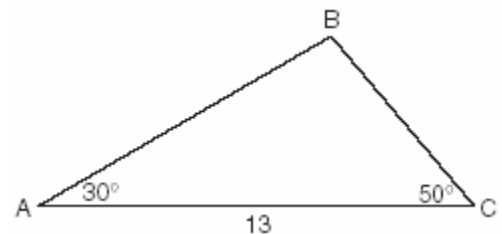

What is the length of side  $\overline{AB}$  to the nearest tenth?  
 [A] 10.1      [B] 6.6      [C] 12.0      [D] 11.5

423. 060527b, P.I. A2.A.73

As shown in the accompanying diagram, two tracking stations,  $A$  and  $B$ , are on an east-west line 110 miles apart. A forest fire is located at  $F$ , on a bearing  $42^\circ$  northeast of station  $A$  and  $15^\circ$  northeast of station  $B$ . How far, to the *nearest mile*, is the fire from station  $A$ ?

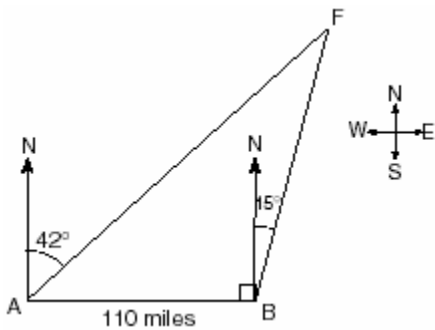

424. 080131b, P.I. A2.A.73

In the accompanying diagram of  $\triangle ABC$ ,  $m\angle A = 65$ ,  $m\angle B = 70$ , and the side opposite vertex  $B$  is 7. Find the length of the side opposite vertex  $A$ , and find the area of  $\triangle ABC$ .

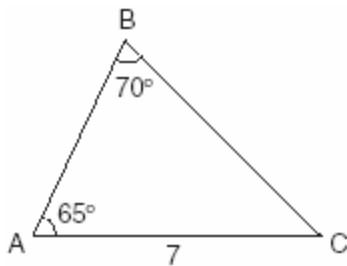

425. 010631b, P.I. A2.A.73

The Vietnam Veterans Memorial in Washington, D.C., is made up of two walls, each 246.75 feet long, that meet at an angle of  $125.2^\circ$ . Find, to the *nearest foot*, the distance between the ends of the walls that do not meet.

426. 080233b, P.I. A2.A.73

Carmen and Jamal are standing 5,280 feet apart on a straight, horizontal road. They observe a hot-air balloon between them directly above the road. The angle of elevation from Carmen is  $60^\circ$  and from Jamal is  $75^\circ$ . Draw a diagram to illustrate this situation and find the height of the balloon to the *nearest foot*.

427. 060728b, P.I. A2.A.73

In the accompanying diagram of a streetlight, the light is attached to a pole at  $R$  and supported by a brace,  $\overline{PQ}$ ,  $RQ = 10$  feet,  $RP = 6$  feet,  $\angle PRQ$  is an obtuse angle, and  $m\angle PQR = 30$ . Find the length of the brace,  $\overline{PQ}$ , to the *nearest foot*.

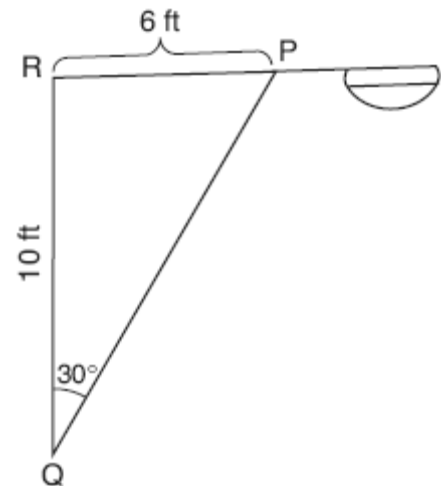



428. 060231b, P.I. A2.A.73

A ship at sea heads directly toward a cliff on the shoreline. The accompanying diagram shows the top of the cliff,  $D$ , sighted from two locations,  $A$  and  $B$ , separated by distance  $S$ . If  $m\angle DAC = 30$ ,  $m\angle DBC = 45$ , and  $S = 30$  feet, what is the height of the cliff, to the nearest foot?

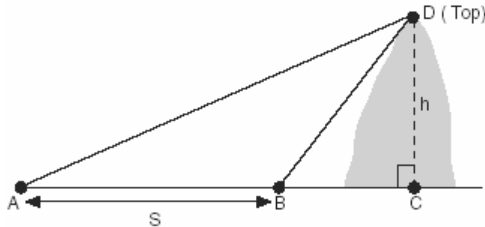

429. 080527b, P.I. A2.A.73

The accompanying diagram shows the plans for a cell-phone tower that is to be built near a busy highway. Find the height of the tower, to the nearest foot.

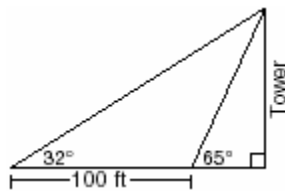

430. 010334b, P.I. A2.A.73

A ship captain at sea uses a sextant to sight an angle of elevation of  $37^\circ$  to the top of a lighthouse. After the ship travels 250 feet directly toward the lighthouse, another sighting is made, and the new angle of elevation is  $50^\circ$ . The ship's charts show that there are dangerous rocks 100 feet from the base of the lighthouse. Find, to the nearest foot, how close to the rocks the ship is at the time of the second sighting.

431. 060332b, P.I. A2.A.73

While sailing a boat offshore, Donna sees a lighthouse and calculates that the angle of elevation to the top of the lighthouse is  $3^\circ$ , as shown in the accompanying diagram. When she sails her boat 700 feet closer to the lighthouse, she finds that the angle of elevation is now  $5^\circ$ . How tall, to the nearest tenth of a foot, is the lighthouse?

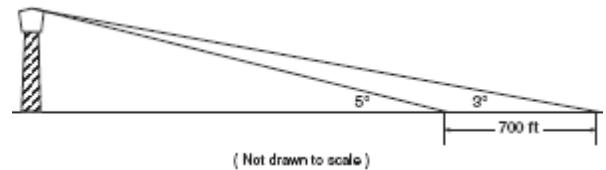

432. 010534b, P.I. A2.A.73

A sign 46 feet high is placed on top of an office building. From a point on the sidewalk level with the base of the building, the angle of elevation to the top of the sign and the angle of elevation to the bottom of the sign are  $40^\circ$  and  $32^\circ$ , respectively. Sketch a diagram to represent the building, the sign, and the two angles, and find the height of the building to the nearest foot.

## MATH TOOLBOX P. 449

### LAW OF SINES - THE AMBIGUOUS CASE

433. 080414b, P.I. A2.A.75

How many distinct triangles can be formed if  $m\angle A = 30$ , side  $b = 12$ , and side  $a = 8$ ?

- [A] 0      [B] 3      [C] 2      [D] 1

434. 080519b, P.I. A2.A.75

What is the total number of distinct triangles that can be constructed if  $AC = 13$ ,  $BC = 8$ , and  $m\angle A = 36^\circ$ ?

- [A] 3      [B] 2      [C] 0      [D] 1

435. 080311b, P.I. A2.A.75  
An architect commissions a contractor to produce a triangular window. The architect describes the window as  $\triangle ABC$ , where  $m\angle A = 50$ ,  $BC = 10$  inches, and  $AB = 12$  inches. How many distinct triangles can the contractor construct using these dimensions?  
[A] 1 [B] 0 [C] more than 2 [D] 2
436. 060416b, P.I. A2.A.75  
Sam is designing a triangular piece for a metal sculpture. He tells Martha that two of the sides of the piece are 40 inches and 15 inches, and the angle opposite the 40-inch side measures  $120^\circ$ . Martha decides to sketch the piece that Sam described. How many different triangles can she sketch that match Sam's description?  
[A] 2 [B] 1 [C] 3 [D] 0
437. 060620b, P.I. A2.A.75  
Sam needs to cut a triangle out of a sheet of paper. The only requirements that Sam must follow are that one of the angles must be  $60^\circ$ , the side opposite the  $60^\circ$  angle must be 40 centimeters, and one of the other sides must be 15 centimeters. How many different triangles can Sam make?  
[A] 3 [B] 1 [C] 2 [D] 0
438. 010426b, P.I. A2.A.75  
A landscape designer is designing a triangular garden with two sides that are 4 feet and 6 feet, respectively. The angle opposite the 4-foot side is  $30^\circ$ . How many distinct triangular gardens can the designer make using these measurements?
439. 060119b, P.I. A2.A.75  
Main Street and Central Avenue intersect, making an angle measuring  $34^\circ$ . Angela lives at the intersection of the two roads, and Caitlin lives on Central Avenue 10 miles from the intersection. If Leticia lives 7 miles from Caitlin, which conclusion is valid?  
[A] Leticia cannot live on Main Street.  
[B] Leticia can live at only one location on Main Street.  
[C] Leticia can live at one of three locations on Main Street.  
[D] Leticia can live at one of two locations on Main Street.
440. 010309b, P.I. A2.A.75  
In  $\triangle ABC$ , if  $AC = 12$ ,  $BC = 11$ , and  $m\angle A = 30$ , angle  $C$  could be  
[A] a right angle, only  
[B] an acute angle, only  
[C] either an obtuse angle or an acute angle  
[D] an obtuse angle, only
441. 010720b, P.I. A2.A.75  
In  $\triangle ABC$ ,  $m\angle A = 30$ ,  $a = 14$ , and  $b = 20$ . Which type of angle is  $\angle B$ ?  
[A] It must be an acute angle.  
[B] It may be either an acute angle or an obtuse angle.  
[C] It must be a right angle.  
[D] It must be an obtuse angle.
442. 060610b, P.I. A2.A.67  
The expression  $\frac{1 - \cos^2 x}{\sin^2 x}$  is equivalent to  
[A] 1 [B]  $\cos x$  [C]  $-1$  [D]  $\sin x$

## NY LESSONS 8 & 9

### TRIGONOMETRIC IDENTITIES

443. 010608b, P.I. A2.A.67  
The expression  $(1 + \cos x)(1 - \cos x)$  is equivalent to

[A] 1 [B]  $\csc^2 x$

[C]  $\sin^2 x$  [D]  $\sec^2 x$

444. 080526b, P.I. A2.A.67  
Express in simplest terms:  $\frac{2 - 2 \sin^2 x}{\cos x}$

445. 080703b, P.I. A2.A.58  
If  $\csc \theta = -2$ , what is the value of  $\sin \theta$ ?

[A]  $-2$  [B]  $2$  [C]  $-\frac{1}{2}$  [D]  $\frac{1}{2}$

446. 060720b, P.I. A2.A.67  
The expression  $\sin A + \frac{\cos^2 A}{\sin A}$  is equivalent to

[A]  $\csc A$  [B]  $\sec A$

[C]  $\sin A$  [D]  $1$

447. 060418b, P.I. A2.A.67  
If  $\theta$  is a positive acute angle and  $\sin \theta = a$ , which expression represents  $\cos \theta$  in terms of  $a$ ?

[A]  $\frac{1}{\sqrt{a}}$  [B]  $\sqrt{1 - a^2}$

[C]  $\sqrt{a}$  [D]  $\frac{1}{\sqrt{1 - a^2}}$

448. 010508b, P.I. A2.A.58  
The expression  $\frac{\tan \theta}{\sec \theta}$  is equivalent to

[A]  $\cos \theta$  [B]  $\frac{\sin \theta}{\cos^2 \theta}$

[C]  $\sin \theta$  [D]  $\frac{\cos^2 \theta}{\sin \theta}$

449. 010402b, P.I. A2.A.58  
The expression  $\frac{\sec \theta}{\csc \theta}$  is equivalent to

[A]  $\cos \theta$  [B]  $\frac{\sin \theta}{\cos \theta}$

[C]  $\sin \theta$  [D]  $\frac{\cos \theta}{\sin \theta}$

450. 060515b  
A crate weighing  $w$  pounds sits on a ramp positioned at an angle of  $\theta$  with the horizontal. The forces acting on this crate are modeled by the equation  $Mw \cos \theta = w \sin \theta$ , where  $M$  is the coefficient of friction. What is an expression for  $M$  in terms of  $\theta$ ?

[A]  $M = \sec \theta$  [B]  $M = \csc \theta$

[C]  $M = \tan \theta$  [D]  $M = \cot \theta$

## NY LESSON 10

### TRIGONOMETRIC EQUATIONS

451. 080610b, P.I. A2.A.68  
A solution set of the equation  $5 \sin \theta + 3 = 3$  contains all multiples of

[A]  $135^\circ$  [B]  $90^\circ$  [C]  $180^\circ$  [D]  $45^\circ$

452. 010523b, P.I. A2.A.68  
Solve the following equation algebraically for all values of  $\theta$  in the interval  $0^\circ \leq \theta \leq 180^\circ$ .  
 $2 \sin \theta - 1 = 0$

453. 010630b, P.I. A2.A.68  
An architect is using a computer program to design the entrance of a railroad tunnel. The outline of the opening is modeled by the function  $f(x) = 8\sin x + 2$ , in the interval  $0 \leq x \leq \pi$ , where  $x$  is expressed in radians. Solve algebraically for all values of  $x$  in the interval  $0 \leq x \leq \pi$ , where the height of the opening,  $f(x)$ , is 6. Express your answer in terms of  $\pi$ . If the  $x$ -axis represents the base of the tunnel, what is the maximum height of the entrance of the tunnel?
454. 060319b, P.I. A2.A.68  
What value of  $x$  in the interval  $0^\circ \leq x \leq 180^\circ$  satisfies the equation  $\sqrt{3}\tan x + 1 = 0$ ?  
[A]  $-30^\circ$  [B]  $60^\circ$  [C]  $30^\circ$  [D]  $150^\circ$
455. 080432b, P.I. A2.A.68  
Solve algebraically for all values of  $\theta$  in the interval  $0^\circ \leq \theta \leq 360^\circ$  that satisfy the equation  $\frac{\sin^2 \theta}{1 + \cos \theta} = 1$ .
456. 060131b, P.I. A2.A.68  
In the interval  $0^\circ \leq A \leq 360^\circ$ , solve for all values of  $A$  in the equation  $\cos 2A = -3\sin A - 1$ .
457. 060427b, P.I. A2.A.68  
Navigators aboard ships and airplanes use nautical miles to measure distance. The length of a nautical mile varies with latitude. The length of a nautical mile,  $L$ , in feet, on the latitude line  $\theta$  is given by the formula  $L = 6,077 - 31\cos 2\theta$ . Find, to the nearest degree, the angle  $\theta$ ,  $0 \leq \theta \leq 90^\circ$ , at which the length of a nautical mile is approximately 6,076 feet.
458. 010832b, P.I. A2.A.68  
The horizontal distance, in feet, that a golf ball travels when hit can be determined by the formula  $d = \frac{v^2 \sin 2\theta}{g}$ , where  $v$  equals initial velocity, in feet per second;  $g$  equals acceleration due to gravity;  $\theta$  equals the initial angle, in degrees, that the path of the ball makes with the ground; and  $d$  equals the horizontal distance, in feet, that the ball will travel. A golfer hits the ball with an initial velocity of 180 feet per second and it travels a distance of 840 feet. If  $g = 32$  feet per second per second, what is the smallest initial angle the path of the ball makes with the ground, to the nearest degree?
459. 060530b, P.I. A2.A.68  
Find, to the nearest degree, all values of  $\theta$  in the interval  $0^\circ < \theta < 360^\circ$  that satisfy the equation  $3\cos 2\theta + \sin \theta - 1 = 0$ .
460. 010829b, P.I. A2.A.68  
Find all values of  $x$  in the interval  $0^\circ < x < 360^\circ$  that satisfy the equation  $3\cos x + \sin 2x = 0$ .
461. 010317b, P.I. A2.A.58  
If  $(\sec x - 2)(2\sec x - 1) = 0$ , then  $x$  terminates in  
[A] Quadrants I and II, only  
[B] Quadrants I and IV, only  
[C] Quadrant I, only  
[D] Quadrants I, II, III, and IV
462. 010727b, P.I. A2.A.68  
Find, to the nearest degree, all values of  $\theta$  in the interval  $0^\circ \leq \theta \leq 180^\circ$  that satisfy the equation  $8\cos^2 \theta - 2\cos \theta - 1 = 0$ .

463. 010404b, P.I. A2.A.27

What is a positive value of  $x$  for which

$$9^{-\cos x} = \frac{1}{3}?$$

- [A]  $60^\circ$  [B]  $30^\circ$  [C]  $45^\circ$  [D]  $90^\circ$

464. 010320b, P.I. A2.A.66

If  $\sin 6A = \cos 9A$ , then  $m\angle A$  is equal to

- [A] 36 [B] 6 [C] 54 [D]  $1\frac{1}{2}$

465. 060731b, P.I. A2.A.68

The average annual snowfall in a certain region is modeled by the function

$$S(t) = 20 + 10\cos\left(\frac{\pi}{5}t\right),$$

where  $S$  represents the

annual snowfall, in inches, and  $t$  represents the number of years since 1970. What is the minimum annual snowfall, in inches, for this region? In which years between 1970 and 2000 did the minimum amount of snow fall? [The use of the grid is optional.]

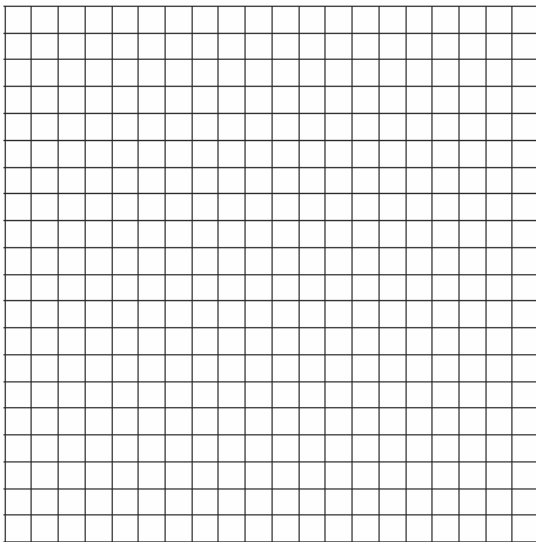

## NY LESSON 11

### DOUBLE ANGLE AND ANGLE SUM AND DIFFERENCE IDENTITIES

466. 010512b, P.I. A2.A.77

If  $A$  is a positive acute angle and  $\sin A = \frac{\sqrt{5}}{3}$ ,

what is  $\cos 2A$ ?

- [A]  $-\frac{1}{3}$  [B]  $\frac{1}{9}$  [C]  $-\frac{1}{9}$  [D]  $\frac{1}{3}$

467. 010418b, P.I. A2.A.77

If  $x$  is an acute angle and  $\sin x = \frac{12}{13}$ , then

$\cos 2x$  equals

[A]  $-\frac{119}{169}$  [B]  $\frac{25}{169}$

[C]  $-\frac{25}{169}$  [D]  $\frac{119}{169}$

468. 010319b, P.I. A2.A.77

If  $\sin \theta = \frac{\sqrt{5}}{3}$ , then  $\cos 2\theta$  equals

- [A]  $\frac{1}{9}$  [B]  $-\frac{1}{9}$  [C]  $-\frac{1}{3}$  [D]  $\frac{1}{3}$

469. 060413b, P.I. A2.A.77

If  $\theta$  is an acute angle such that  $\sin \theta = \frac{5}{13}$ ,

what is the value of  $\sin 2\theta$ ?

- [A]  $\frac{60}{169}$  [B]  $\frac{12}{13}$  [C]  $\frac{10}{26}$  [D]  $\frac{120}{169}$

470. 010609b, P.I. A2.A.77

If  $\theta$  is a positive acute angle and

$\sin 2\theta = \frac{\sqrt{3}}{2}$ , then  $(\cos \theta + \sin \theta)^2$  equals

- [A]  $1 + \frac{\sqrt{3}}{2}$  [B]  $30^\circ$  [C]  $60^\circ$  [D] 1

471. 060604b, P.I. A2.A.77

If  $x$  is a positive acute angle and  $\sin x = \frac{1}{2}$ ,

what is  $\sin 2x$ ?

- [A]  $\frac{\sqrt{3}}{2}$  [B]  $\frac{1}{2}$  [C]  $-\frac{1}{2}$  [D]  $-\frac{\sqrt{3}}{2}$

472. 080617b, P.I. A2.A.77

The expression  $\frac{\sin 2\theta}{\sin^2 \theta}$  is equivalent to

- [A]  $2 \cot \theta$  [B]  $\frac{2}{\sin \theta}$   
[C]  $2 \cos \theta$  [D]  $2 \tan \theta$

473. 080315b, P.I. A2.A.77

The expression  $\frac{2 \cos \theta}{\sin 2\theta}$  is equivalent to

- [A]  $\cot \theta$  [B]  $\sin \theta$   
[C]  $\sec \theta$  [D]  $\csc \theta$

474. 080126b, P.I. A2.A.76

If  $\sin x = \frac{4}{5}$ , where  $0^\circ < x < 90^\circ$ , find the value of  $\cos(x + 180^\circ)$ .

475. 060312b, P.I. A2.A.76

If  $A$  and  $B$  are positive acute angles,  
 $\sin A = \frac{5}{13}$ , and  $\cos B = \frac{4}{5}$ , what is the value of  $\sin(A + B)$ ?

- [A]  $-\frac{16}{65}$  [B]  $\frac{56}{65}$  [C]  $\frac{63}{65}$  [D]  $\frac{33}{65}$

476. 080409b, P.I. A2.A.76

If  $\sin A = \frac{4}{5}$ ,  $\tan B = \frac{5}{12}$ , and angles  $A$  and  $B$  are in Quadrant I, what is the value of  $\sin(A + B)$ ?

- [A]  $-\frac{33}{65}$  [B]  $\frac{33}{65}$  [C]  $\frac{63}{65}$  [D]  $-\frac{63}{65}$

477. 080316b, P.I. A2.A.76

If  $\sin x = \frac{12}{13}$ ,  $\cos y = \frac{3}{5}$ , and  $x$  and  $y$  are acute angles, the value of  $\cos(x - y)$  is

- [A]  $\frac{21}{65}$  [B]  $-\frac{33}{65}$  [C]  $-\frac{14}{65}$  [D]  $\frac{63}{65}$

478. 010401b, P.I. A2.A.76

The expression  $\cos 40^\circ \cos 10^\circ + \sin 40^\circ \sin 10^\circ$  is equivalent to

- [A]  $\cos 50^\circ$  [B]  $\sin 30^\circ$   
[C]  $\cos 30^\circ$  [D]  $\sin 50^\circ$

## CHAPTER 10-4

### EQUATIONS OF ELLIPSES

479. 080517b

An object orbiting a planet travels in a path represented by the equation

$3(y + 1)^2 + 5(x + 4)^2 = 15$ . In which type of pattern does the object travel?

- [A] ellipse [B] parabola  
[C] hyperbola [D] circle

480. 010410b

The accompanying diagram shows the elliptical orbit of a planet. The foci of the elliptical orbit are  $F_1$  and  $F_2$ .

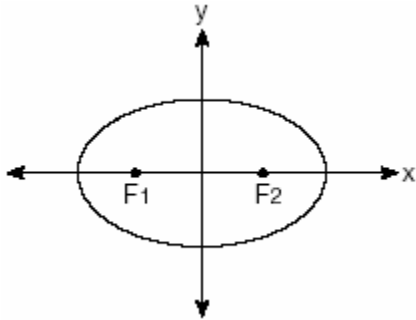

If  $a$ ,  $b$ , and  $c$  are all positive and  $a \neq b \neq c$ , which equation could represent the path of the planet?

- [A]  $ax^2 - by^2 = c^2$       [B]  $ax^2 + by^2 = c^2$   
[C]  $x^2 + y^2 = c^2$       [D]  $y = ax^2 + c^2$

481. 060512b

Which equation, when graphed on a Cartesian coordinate plane, would best represent an elliptical racetrack?

- [A]  $3x + 10y = 288,000$   
[B]  $3x^2 - 10y^2 = 288,000$   
[C]  $3x^2 + 10y^2 = 288,000$   
[D]  $30xy = 288,000$

482. 080609b

A designer who is planning to install an elliptical mirror is laying out the design on a coordinate grid. Which equation could represent the elliptical mirror?

- [A]  $x^2 + 4y^2 = 144$       [B]  $y = 4y^2 + 144$   
[C]  $x^2 = 144 + 36y^2$       [D]  $x^2 + y^2 = 144$

483. 060311b

The accompanying diagram represents the elliptical path of a ride at an amusement park.

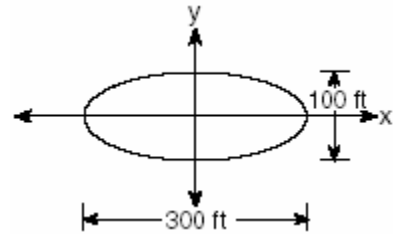

Which equation represents this path?

- [A]  $y = x^2 + 100x + 300$   
[B]  $\frac{x^2}{150^2} - \frac{y^2}{50^2} = 1$   
[C]  $x^2 + y^2 = 300$       [D]  $\frac{x^2}{150^2} + \frac{y^2}{50^2} = 1$

484. 080318b

A commercial artist plans to include an ellipse in a design and wants the length of the horizontal axis to equal 10 and the length of the vertical axis to equal 6. Which equation could represent this ellipse?

- [A]  $9x^2 - 25y^2 = 225$   
[B]  $9x^2 + 25y^2 = 225$   
[C]  $3y = 20x^2$       [D]  $x^2 + y^2 = 100$

485. 080206b

An architect is designing a building to include an arch in the shape of a semi-ellipse (half an ellipse), such that the width of the arch is 20 feet and the height of the arch is 8 feet, as shown in the accompanying diagram.

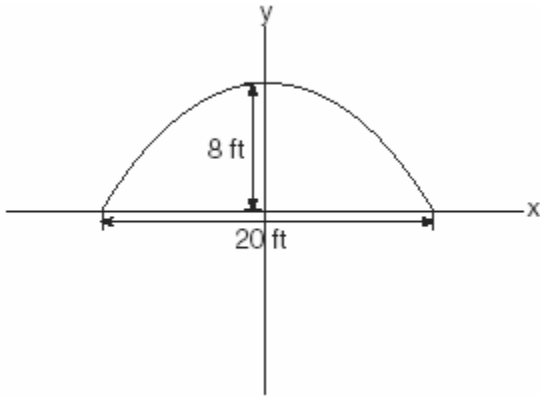

Which equation models this arch?

- [A]  $\frac{x^2}{64} + \frac{y^2}{400} = 1$       [B]  $\frac{x^2}{100} + \frac{y^2}{64} = 1$   
 [C]  $\frac{x^2}{64} + \frac{y^2}{100} = 1$       [D]  $\frac{x^2}{400} + \frac{y^2}{64} = 1$

486. 010517b

The accompanying diagram shows the construction of a model of an elliptical orbit of a planet traveling around a star. Point  $P$  and the center of the star represent the foci of the orbit.

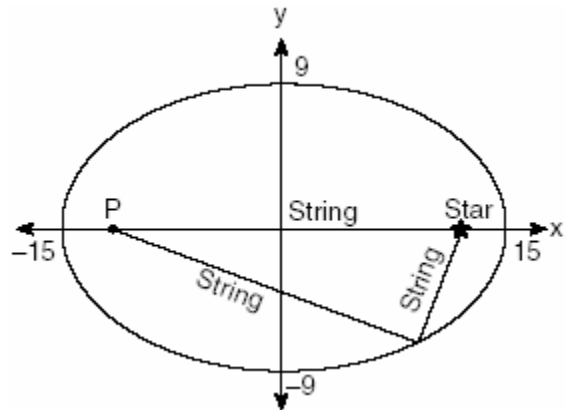

Which equation could represent the relation shown?

- [A]  $\frac{x^2}{15} - \frac{y^2}{9} = 1$       [B]  $\frac{x^2}{225} + \frac{y^2}{81} = 1$   
 [C]  $\frac{x^2}{15} + \frac{y^2}{9} = 1$       [D]  $\frac{x^2}{81} + \frac{y^2}{225} = 1$



487. 060730b

A landscape architect is working on the plans for a new horse farm. He is laying out the exercise ring and racetrack on the accompanying graph. The location of the circular exercise ring, with point  $R$  as its center, has already been plotted.

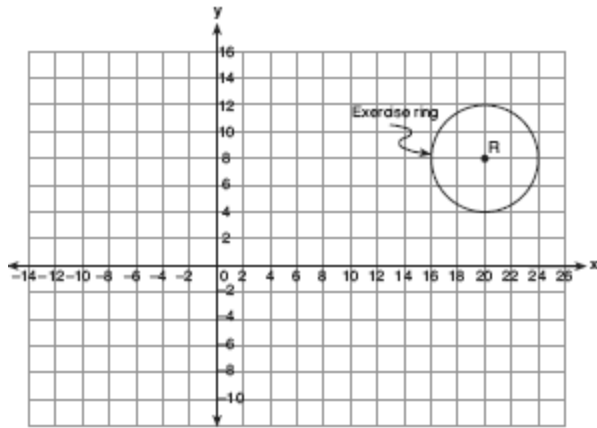

Write an equation that represents the outside edge of the exercise ring. The equation of the

outside edge of the racetrack is  $\frac{x^2}{144} + \frac{y^2}{36} = 1$ .

Sketch the outside edge of the racetrack on the graph.

**SOLVING NONLINEAR SYSTEMS**

488. 060627b

Solve the following system of equations algebraically:

$$9x^2 + y^2 = 9$$

$$3x - y = 3$$

**CHAPTER 11-3**

**CORRELATION COEFFICIENT**

489. 060211b, P.I. A2.S.8

A linear regression equation of best fit between a student's attendance and the degree of success in school is  $h = 0.5x + 68.5$ . The correlation coefficient,  $r$ , for these data would be

- [A]  $r = 0$                       [B]  $-1 < r < 0$   
[C]  $0 < r < 1$                 [D]  $r = -1$

490. 060109b, P.I. A2.S.8

The relationship of a woman's shoe size and length of a woman's foot, in inches, is given in the accompanying table.

Woman's Shoe Size	5	6	7	8
Foot Length (in)	9.00	9.25	9.50	9.75

The linear correlation coefficient for this relationship is

- [A] -1      [B] 1      [C] 0      [D] 0.5

491. 010515b, P.I. A2.S.8

Which scatter diagram shows the strongest positive correlation?

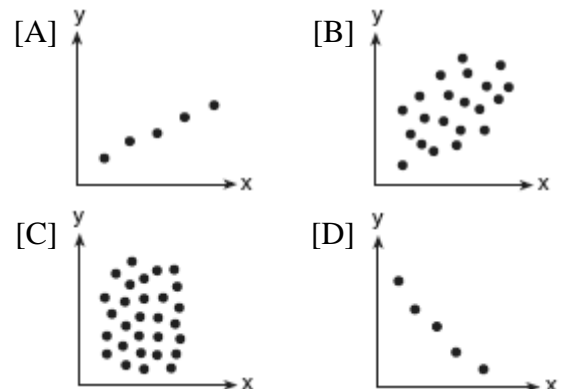

492. 080306b, P.I. A2.S.8

Which graph represents data used in a linear regression that produces a correlation coefficient closest to  $-1$ ?

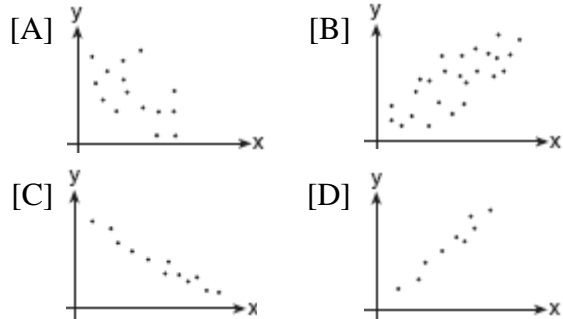

493. 010816b, P.I. A2.S.8

In the physics lab, Thelma determined the kinetic energy,  $KE$ , of an object at various velocities,  $V$ , and found the linear correlation coefficient between  $KE$  and  $V$  to be  $+0.8$ . Which graph shows this relationship?

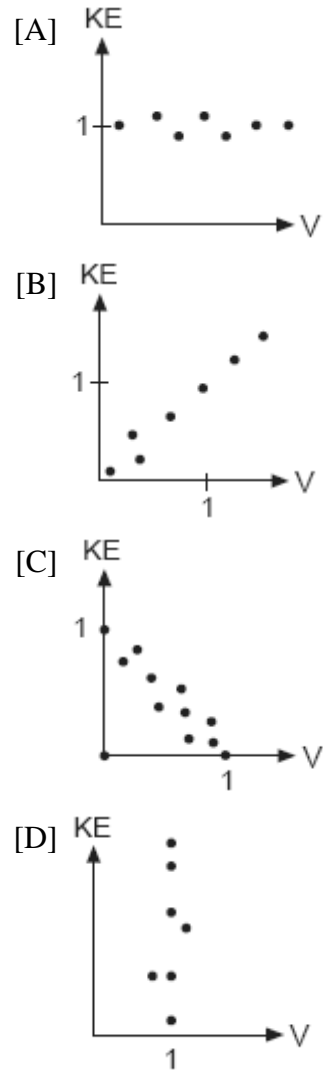

494. 060705b, P.I. A2.S.8

What could be the approximate value of the correlation coefficient for the accompanying scatter plot?

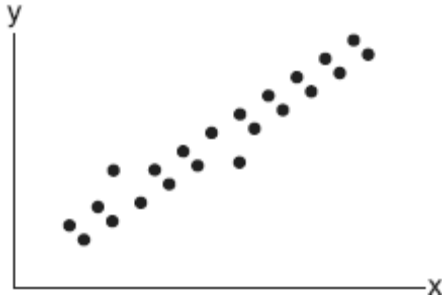

- [A] 0.90 [B] -0.85 [C] -0.16 [D] 0.21

## CHAPTER 11-4

### STANDARD DEVIATION

495. 010604b

On a standardized test, a score of 86 falls exactly 1.5 standard deviations below the mean. If the standard deviation for the test is 2, what is the mean score for this test?

- [A] 89 [B] 84.5 [C] 84 [D] 87.5

496. 060221b

On a nationwide examination, the Adams School had a mean score of 875 and a standard deviation of 12. The Boswell School had a mean score of 855 and a standard deviation of 20. In which school was there greater consistency in the scores? Explain how you arrived at your answer.

497. 010707b, P.I. A2.S.4

The term “snowstorms of note” applies to all snowfalls over 6 inches. The snowfall amounts for snowstorms of note in Utica, New York, over a four-year period are as follows: 7.1, 9.2, 8.0, 6.1, 14.4, 8.5, 6.1, 6.8, 7.7, 21.5, 6.7, 9.0, 8.4, 7.0, 11.5, 14.1, 9.5, 8.6. What are the mean and population standard deviation for these data, to the *nearest hundredth*?

- [A] mean = 9.45; standard deviation = 3.74  
[B] mean = 9.46; standard deviation = 3.85  
[C] mean = 9.45; standard deviation = 3.85  
[D] mean = 9.46; standard deviation = 3.74

498. 060630b, P.I. A2.S.4

The number of children of each of the first 41 United States presidents is given in the accompanying table. For this population, determine the mean and the standard deviation to the *nearest tenth*. How many of these presidents fall within one standard deviation of the mean?

Number of Children ( $x_j$ )	Number of Presidents ( $f_j$ )
0	6
1	2
2	8
3	6
4	7
5	3
6	5
7	1
8	1
10	1
15	1

499. 060729b, P.I. A2.S.4  
Conant High School has 17 students on its championship bowling team. Each student bowled one game. The scores are listed in the accompanying table.

Score ( $x_i$ )	Frequency ( $f_i$ )
140	4
145	3
150	2
160	3
170	2
180	2
194	1

Find, to the *nearest tenth*, the population standard deviation of these scores. How many of the scores fall within one standard deviation of the mean?

500. 080730b, P.I. A2.S.4  
Mr. Koziol has 17 students in his high school golf club. Each student played one round of golf. The summarized scores of the students are listed in the accompanying table.

Score	Frequency
70	4
73	3
75	2
80	3
85	1
86	1
90	2
92	1

Find the population standard deviation of this set of students' scores, to the *nearest tenth*. How many of the individual students' golf scores fall within one population standard deviation of the mean?

501. 080625b, P.I. A2.S.4  
Beth's scores on the six Earth science tests she took this semester are 100, 95, 55, 85, 75, and 100. For this population, how many scores are within one standard deviation of the mean?
502. 010529b, P.I. A2.S.4  
From 1984 to 1995, the winning scores for a golf tournament were 276, 279, 279, 277, 278, 278, 280, 282, 285, 272, 279, and 278. Using the standard deviation for the sample,  $S_x$ , find the percent of these winning scores that fall within one standard deviation of the mean.
503. 060227b, P.I. A2.S.4  
An electronics company produces a headphone set that can be adjusted to accommodate different-sized heads. Research into the distance between the top of people's heads and the top of their ears produced the following data, in inches: 4.5, 4.8, 6.2, 5.5, 5.6, 5.4, 5.8, 6.0, 5.8, 6.2, 4.6, 5.0, 5.4, 5.8. The company decides to design their headphones to accommodate three standard deviations from the mean. Find, to the *nearest tenth*, the mean, the standard deviation, and the range of distances that must be accommodated.

504. 010406b, P.I. A2.S.4  
Jean's scores on five mathematics tests were 98, 97, 99, 98, and 96. Her scores on five English tests were 78, 84, 95, 72, and 79. Which statement is true about the standard deviations for the scores?
- [A] The standard deviation for the English scores is greater than the standard deviation for the math scores.
- [B] The standard deviations for both sets of scores are equal.
- [C] More information is needed to determine the relationship between the standard deviations.
- [D] The standard deviation for the math scores is greater than the standard deviation for the English scores.

## CHAPTER 11-7

### NORMAL DISTRIBUTIONS

505. 010308b, P.I. A2.S.5  
The national mean for verbal scores on an exam was 428 and the standard deviation was 113. Approximately what percent of those taking this test had verbal scores between 315 and 541?
- [A] 38.2%                      [B] 26.4%
- [C] 68.2%                      [D] 52.8%
506. 080202b, P.I. A2.S.5  
In a New York City high school, a survey revealed the mean amount of cola consumed each week was 12 bottles and the standard deviation was 2.8 bottles. Assuming the survey represents a normal distribution, how many bottles of cola per week will approximately 68.2% of the students drink?
- [A] 12 to 20.4                      [B] 6.4 to 12
- [C] 6.4 to 17.6                      [D] 9.2 to 14.8
507. 060412b, P.I. A2.S.5  
The amount of juice dispensed from a machine is normally distributed with a mean of 10.50 ounces and a standard deviation of 0.75 ounce. Which interval represents the amount of juice dispensed about 68.2% of the time?
- [A] 9.00-12.00                      [B] 9.75-10.50
- [C] 9.75-11.25                      [D] 10.50-11.25
508. 080129b, P.I. A2.S.5  
Twenty high school students took an examination and received the following scores: 70, 60, 75, 68, 85, 86, 78, 72, 82, 88, 88, 73, 74, 79, 86, 82, 90, 92, 93, 73. Determine what percent of the students scored within one standard deviation of the mean. Do the results of the examination approximate a normal distribution? Justify your answer.
509. 060432b, P.I. A2.S.5  
Mrs. Ramírez is a real estate broker. Last month, the sale prices of homes in her area approximated a normal distribution with a mean of \$150,000 and a standard deviation of \$25,000. A house had a sale price of \$175,000. What is the percentile rank of its sale price, to the *nearest whole number*? Explain what that percentile means. Mrs. Ramírez told a customer that most of the houses sold last month had selling prices between \$125,000 and \$175,000. Explain why she is correct.
510. 080405b, P.I. A2.S.5  
The mean of a normally distributed set of data is 56, and the standard deviation is 5. In which interval do approximately 95.4% of all cases lie?
- [A] 46-56                      [B] 51-61
- [C] 56-71                      [D] 46-66

511. 010411b, P.I. A2.S.5  
Battery lifetime is normally distributed for large samples. The mean lifetime is 500 days and the standard deviation is 61 days. Approximately what percent of batteries have lifetimes *longer than* 561 days?  
[A] 34% [B] 84% [C] 16% [D] 68%
512. 080317b, P.I. A2.S.5  
The amount of ketchup dispensed from a machine at Hamburger Palace is normally distributed with a mean of 0.9 ounce and a standard deviation of 0.1 ounce. If the machine is used 500 times, approximately how many times will it be expected to dispense 1 or more ounces of ketchup?  
[A] 100 [B] 5 [C] 80 [D] 16
513. 060126b, P.I. A2.S.5  
Professor Bartrich has 184 students in her mathematics class. The scores on the final examination are normally distributed and have a mean of 72.3 and a standard deviation of 8.9. How many students in the class can be expected to receive a score between 82 and 90?
514. 010809b, P.I. A2.S.5  
On a standardized test with a normal distribution, the mean was 64.3 and the standard deviation was 5.4. What is the best approximation of the percent of scores that fell between 61.6 and 75.1?  
[A] 38.2% [B] 95%  
[C] 68.2% [D] 66.8%
515. 060206b, P.I. A2.S.5  
On a standardized test, the distribution of scores is normal, the mean of the scores is 75, and the standard deviation is 5.8. If a student scored 83, the student's score ranks  
[A] above the 97th percentile  
[B] between the 75th percentile and the 84th percentile  
[C] between the 84th percentile and the 97th percentile  
[D] below the 75th percentile
516. 080515b, P.I. A2.S.5  
The mean score on a normally distributed exam is 42 with a standard deviation of 12.1. Which score would be expected to occur less than 5% of the time?  
[A] 32 [B] 67 [C] 60 [D] 25
517. 060324b, P.I. A2.S.5  
In a certain school district, the ages of all new teachers hired during the last 5 years are normally distributed. Within this curve, 95.4% of the ages, centered about the mean, are between 24.6 and 37.4 years. Find the mean age and the standard deviation of the data.

### **NORMAL PROBABILITY**

518. 010226b, P.I. A2.S.5  
A set of normally distributed student test scores has a mean of 80 and a standard deviation of 4. Determine the probability that a randomly selected score will be between 74 and 82.
519. 080222b, P.I. A2.S.5  
The amount of time that a teenager plays video games in any given week is normally distributed. If a teenager plays video games an average of 15 hours per week, with a standard deviation of 3 hours, what is the probability of a teenager playing video games between 15 and 18 hours a week?

520. 010327b, P.I. A2.S.5  
A shoe manufacturer collected data regarding men's shoe sizes and found that the distribution of sizes exactly fits the normal curve. If the mean shoe size is 11 and the standard deviation is 1.5, find:  
*a* the probability that a man's shoe size is greater than or equal to 11  
*b* the probability that a man's shoe size is greater than or equal to 12.5  
*c*  $\frac{P(\text{size} \geq 12.5)}{P(\text{size} \geq 8)}$
521. 060326b, P.I. A2.N.10  
Evaluate:  $2 \sum_{n=1}^5 (2n - 1)$
522. 010601b, P.I. A2.N.10  
What is the value of  $\sum_{n=1}^5 (-2n + 100)$ ?  
[A] 470 [B] 70 [C] 530 [D] 130
523. 060201b, P.I. A2.N.10  
What is the value of  $\sum_{m=2}^5 (m^2 - 1)$ ?  
[A] 53 [B] 50 [C] 54 [D] 58
524. 080521b, P.I. A2.N.10  
Evaluate:  $\sum_{n=1}^5 (n^2 + n)$
525. 060117b, P.I. A2.N.10  
What is the value of  $\sum_{m=1}^3 (2m + 1)^{m-1}$ ?  
[A] 55 [B] 245 [C] 15 [D] 57
526. 060421b, P.I. A2.N.10  
The projected total annual profits, in dollars, for the Nutyme Clothing Company from 2002 to 2004 can be approximated by the model  $\sum_{n=0}^2 (13,567n + 294)$ , where *n* is the year and *n* = 0 represents 2002. Use this model to find the company's projected total annual profits, in dollars, for the period 2002 to 2004.
527. 080418b, P.I. A2.N.10  
A ball is dropped from a height of 8 feet and allowed to bounce. Each time the ball bounces, it bounces back to half its previous height. The vertical distance the ball travels, *d*, is given by the formula  $d = 8 + 16 \sum_{k=1}^n \left(\frac{1}{2}\right)^k$ , where *n* is the number of bounces. Based on this formula, what is the total vertical distance that the ball has traveled after four bounces?  
[A] 22.0 ft [B] 8.9 ft  
[C] 23.0 ft [D] 15.0 ft
528. 060624b, P.I. A2.N.10  
Evaluate:  $\sum_{k=1}^2 \frac{(-1)^{k-1}}{(2k - 1)!}$
529. 080213b, P.I. A2.N.10  
If  ${}_n C_r$  represents the number of combinations of *n* items taken *r* at a time, what is the value of  $\sum_{r=1}^3 {}_4 C_r$ ?  
[A] 6 [B] 4 [C] 24 [D] 14
530. 010505b, P.I. A2.N.10  
The value of  $\sum_{r=2}^4 {}_5 C_r$  is  
[A] 5 [B] 25 [C] 45 [D] 10
531. 060523b, P.I. A2.N.10  
Evaluate:  $\sum_{k=0}^3 (3 \cos k\pi + 1)$

532. 010304b, P.I. A2.N.10

What is the value of  $\sum_{b=0}^3 (2 - (b)i)$  ?

- [A]  $2-6i$  [B]  $8-6i$  [C]  $8-5i$  [D]  $2-5i$

533. 010825b, P.I. A2.N.10

If  $i = \sqrt{-1}$ , what is the value of the  
expression  $\sum_{n=1}^{20} i^{4n}$  ?

534. 080614b, P.I. A2.N.10

Jonathan's teacher required him to express the

sum  $\frac{2}{3} + \frac{3}{4} + \frac{4}{5} + \frac{5}{6} + \frac{6}{7}$  using sigma notation.

Jonathan proposed four possible answers.

Which of these four answers is *not* correct?

[A]  $\sum_{k=1}^5 \frac{k}{k+1}$

[B]  $\sum_{k=1}^5 \frac{k+1}{k+2}$

[C]  $\sum_{k=3}^7 \frac{k-1}{k}$

[D]  $\sum_{k=2}^6 \frac{k}{k+1}$

535. 060714b, P.I. A2.N.10

The expression  $1 + \sqrt{2} + \sqrt[3]{3}$  is equivalent to

[A]  $\sum_{n=1}^3 n^{\frac{1}{n}}$

[B]  $\sum_{n=1}^3 \sqrt[n]{n}$

[C]  $\sum_{n=1}^3 n^{-n}$

[D]  $\sum_{n=0}^3 n^n$