

# JEFFERSON MATH PROJECT

## REGENTS BY CHAPTER

All 1530 NY Math A & B Regents Exam Questions from  
June 1999 to June 2007 Sorted by Prentice Hall Chapter  
ADVANCED ALGEBRA

[www.jmap.org](http://www.jmap.org)



Dear Sir

I have to acknowledge the receipt of your favor of May 14. in which you mention that you have finished the 6. first books of Euclid, plane trigonometry, surveying & algebra and ask whether I think a further pursuit of that branch of science would be useful to you. there are some propositions in the latter books of Euclid, & some of Archimedes, which are useful, & I have no doubt you have been made acquainted with them. trigonometry, so far as this, is most valuable to every man, there is scarcely a day in which he will not resort to it for some of the purposes of common life. the science of calculation also is indispensable as far as the extraction of the square & cube roots; Algebra as far as the quadratic equation & the use of logarithms are often of value in ordinary cases: but all beyond these is but a luxury; a delicious luxury indeed; but not to be indulged in by one who is to have a profession to follow for his subsistence. in this light I view the conic sections, curves of the higher orders, perhaps even spherical trigonometry, Algebraical operations beyond the 2d dimension, and fluxions.

Letter from Thomas Jefferson to William G. Munford, Monticello, June 18, 1799.

# TABLE OF CONTENTS

## ADVANCED ALGEBRA

	<u>PRENTICE HALL CHAPTER</u>	<u>QUESTION NUMBER</u>
CH1	Patterns, Models, and Functions	1-29
CH2	Linear Relationships and Functions	30-44
CH5	Quadratic Equations and Functions	45-127
CH6	Polynomials and Polynomial Functions	128-164
CH7	Exponential and Logarithmic Functions	165-223
CH8	Rational Functions	224-285
CH9	Periodic Functions and Trigonometry	286-405
CH10	Quadratic Relations	406-422
CH11	More Probability and Statistics	423-455
CH12	Sequences and Series	456-469

# CHAPTER 1-3

## DEFINING FUNCTIONS

1. Which graph is *not* a function?

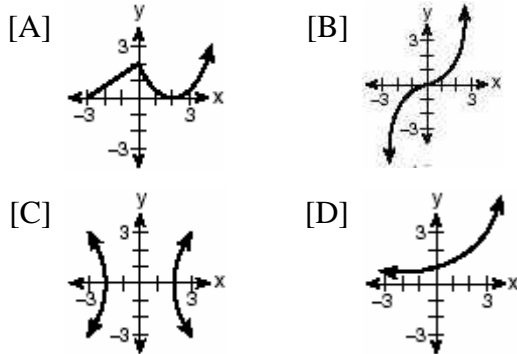

2. Which graph does not represent a function of  $x$ ?

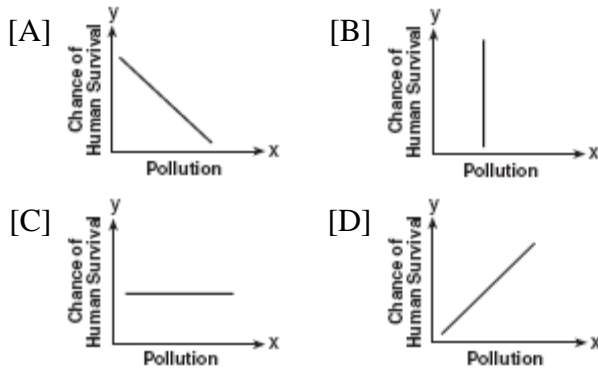

3. Each graph below represents a possible relationship between temperature and pressure. Which graph does *not* represent a function?

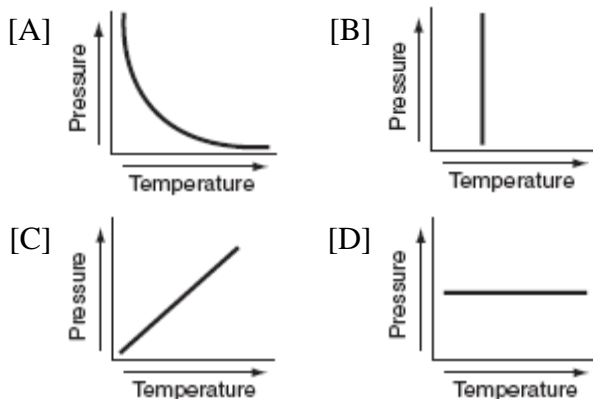

4. Which set of ordered pairs is *not* a function?

- [A]  $\{(4,1), (5,1), (6,1), (7,1)\}$
- [B]  $\{(1,2), (3,4), (4,5), (5,6)\}$
- [C]  $\{(3,1), (2,1), (1,2), (3,2)\}$
- [D]  $\{(0,0), (1,1), (2,2), (3,3)\}$

5. Which set of ordered pairs does *not* represent a function?

- [A]  $\{(3,-2), (4,-3), (5,-4), (6,-5)\}$
- [B]  $\{(3,-2), (-2,3), (4,-1), (-1,4)\}$
- [C]  $\{(3,-2), (3,-4), (4,-1), (4,-3)\}$
- [D]  $\{(3,-2), (5,-2), (4,-2), (-1,-2)\}$

6. Which relation is *not* a function?

- [A]  $y = 2x + 4$
- [B]  $y = x^2 - 4x + 3$
- [C]  $x = 3y - 2$
- [D]  $x = y^2 + 2x - 3$

7. Which equation does *not* represent a function?

- [A]  $y = 4$
- [B]  $y = x^2 + 5x$
- [C]  $x = \pi$
- [D]  $y = |x|$

8. On the accompanying diagram, draw a mapping of a relation from set  $A$  to set  $B$  that is *not* a function. Explain why the relationship you drew is *not* a function.

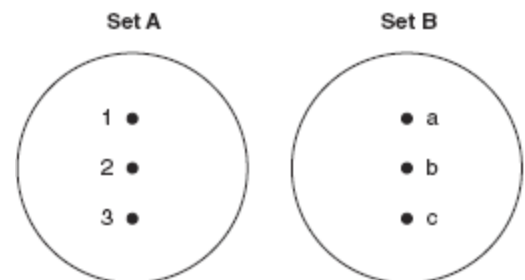

9. Which relation is a function?

- [A]  $y = \sin x$
- [B]  $x = y^2 + 1$
- [C]  $x = 4$
- [D]  $x^2 + y^2 = 16$

10. Which equation represents a function?

[A]  $y = x^2 - 3x - 4$       [B]  $x = y^2 - 6x + 8$

[C]  $x^2 + y^2 = 4$       [D]  $4y^2 = 36 - 9x^2$

11. Which relation is a function?

[A]  $x = 7$       [B]  $x^2 + y^2 = 7$

[C]  $xy = 7$       [D]  $x^2 - y^2 = 7$

12. Which diagram represents a relation in which each member of the domain corresponds to only one member of its range?

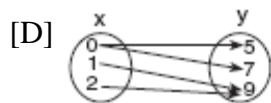
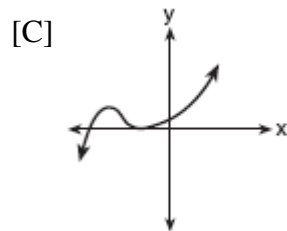
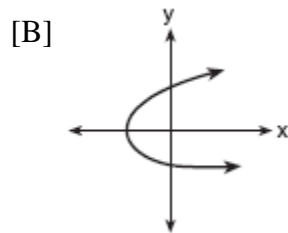
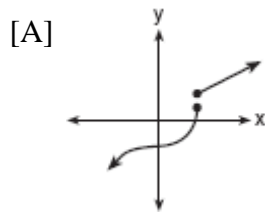

13. Which diagram represents a one-to-one function?

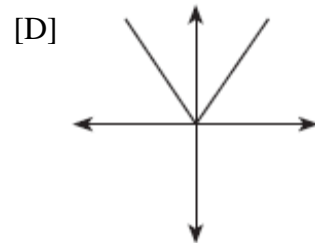
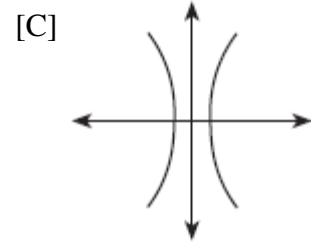
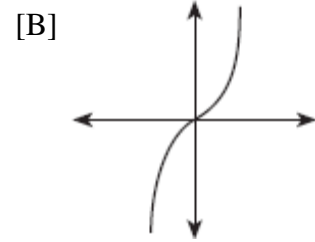
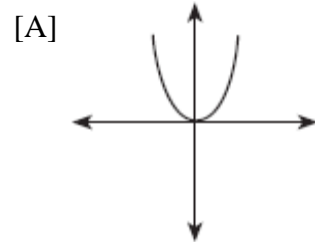

## CHAPTER 1-4

### COMPOSITIONS OF FUNCTIONS

14. If  $f(x) = -2x + 7$  and  $g(x) = x^2 - 2$ , then  $f(g(3))$  is equal to

- [A] -1      [B] -3      [C] -7      [D] 7

15. If  $f(x) = 5x^2 - 1$  and  $g(x) = 3x - 1$ , find  $g(f(1))$ .

16. If  $f(x) = 2^x - 1$  and  $g(x) = x^2 - 1$ , determine the value of  $(f \circ g)(3)$ .



28. The cost ( $C$ ) of selling  $x$  calculators in a store is modeled by the equation  $C = \frac{3,200,000}{x} + 60,000$ . The store profit ( $P$ ) for these sales is modeled by the equation  $P = 500x$ . What is the minimum number of calculators that have to be sold for profit to be greater than cost?
29. A company calculates its profit by finding the difference between revenue and cost. The cost function of producing  $x$  hammers is  $C(x) = 4x + 170$ . If each hammer is sold for \$10, the revenue function for selling  $x$  hammers is  $R(x) = 10x$ .  
How many hammers must be sold to make a profit?  
How many hammers must be sold to make a profit of \$100?

32. What is the solution set of the inequality  $|3 - 2x| \geq 4$ ?
- [A]  $\{x | -\frac{1}{2} \leq x \leq \frac{7}{2}\}$   
[B]  $\{x | x \leq -\frac{1}{2} \text{ or } x \geq \frac{7}{2}\}$   
[C]  $\{x | x \leq \frac{7}{2} \text{ or } x \geq \frac{1}{2}\}$   
[D]  $\{x | \frac{7}{2} \leq x \leq -\frac{1}{2}\}$
33. What is the solution of the inequality  $|x + 3| \leq 5$ ?
- [A]  $x \leq -8 \text{ or } x \geq 2$       [B]  $-8 \leq x \leq 2$   
[C]  $-2 \leq x \leq 8$       [D]  $x \leq -2 \text{ or } x \geq 8$

## CHAPTER 2-4

### ABSOLUTE VALUE INEQUALITIES

30. Which equation states that the temperature,  $t$ , in a room is less than  $3^\circ$  from  $68^\circ$ ?
- [A]  $|68 + t| < 3$       [B]  $|68 - t| < 3$   
[C]  $|3 - t| < 68$       [D]  $|3 + t| < 68$
31. The solution set of  $|3x + 2| < 1$  contains
- [A] both positive and negative real numbers  
[B] only negative real numbers  
[C] only positive real numbers  
[D] no real numbers

34. The solution of  $|2x - 3| < 5$  is
- [A]  $x < 4$       [B]  $-1 < x < 4$   
[C]  $x > -1$       [D]  $x < -1 \text{ or } x > 4$
35. What is the solution of the inequality  $|y + 8| > 3$ ?
- [A]  $-11 < y < -5$       [B]  $y > -5 \text{ or } y < -11$   
[C]  $-5 < y < 11$       [D]  $y > -5$
36. What is the solution set of the inequality  $|2x - 1| < 9$ ?
- [A]  $\{x | x < -4\}$       [B]  $\{x | x < -4 \text{ or } x > 5\}$   
[C]  $\{x | -4 < x < 5\}$       [D]  $\{x | x < 5\}$
37. Which graph represents the solution set of  $|2x - 1| < 7$ ?

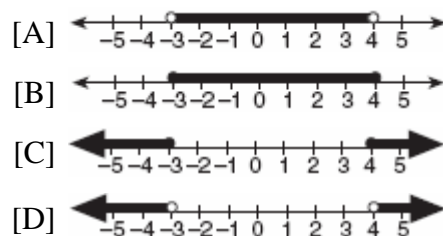

38. Which graph represents the solution set for the expression  $|2x + 3| > 7$ ?

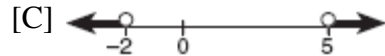

39. The solution set of which inequality is represented by the accompanying graph?

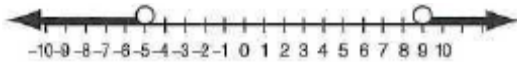

[A]  $|x - 2| < 7$       [B]  $|x - 2| > 7$

[C]  $|2 - x| > -7$       [D]  $|2 - x| < -7$

40. The inequality  $|15C - 24| \leq 30$  represents the range of monthly average temperatures,  $C$ , in degrees Celsius, for Toledo, Ohio. Solve for  $C$ .

41. The heights,  $h$ , of the students in the chorus at Central Middle School satisfy the inequality

$$\left| \frac{h - 57.5}{2} \right| \leq 3.25, \text{ when } h \text{ is measured in}$$

*inches*. Determine the interval in which these heights lie and express your answer to the *nearest tenth of a foot*. [Only an algebraic solution can receive full credit.]

42. A depth finder shows that the water in a certain place is 620 feet deep. The difference between  $d$ , the actual depth of the water, and the reading is  $|d - 620|$  and must be less than or equal to  $0.05d$ . Find the minimum and maximum values of  $d$ , to the *nearest tenth of a foot*.

## CHAPTER 2-5

### ABSOLUTE VALUE

43. Which equation is represented by the accompanying graph?

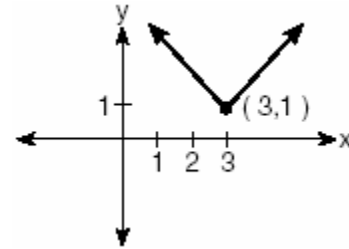

[A]  $y = (x - 3)^2 + 1$       [B]  $y = |x + 3| - 1$

[C]  $y = |x - 3| + 1$       [D]  $y = |x| - 3$

44. The graph below represents  $f(x)$ .

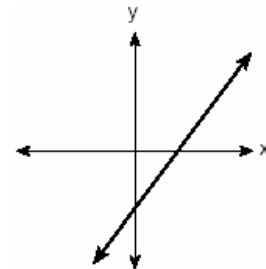

Which graph best represents  $|f(x)|$ ?

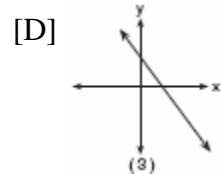
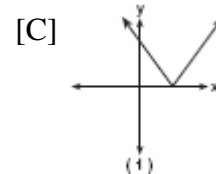
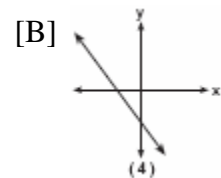
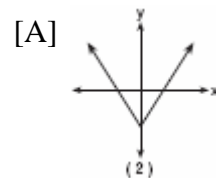

## CHAPTER 5-2

### MINIMUM AND MAXIMUM OF QUADRATICS

45. What is the turning point, or vertex, of the parabola whose equation is  $y = 3x^2 + 6x - 1$ ?

- [A] (-1,-4)                      [B] (-3,8)  
[C] (1,8)                         [D] (3,44)

46. What is the minimum point of the graph of the equation  $y = 2x^2 + 8x + 9$ ?

- [A] (2,33)                        [B] (-2,1)  
[C] (-2,-15)                    [D] (2,17)

47. An archer shoots an arrow into the air such that its height at any time,  $t$ , is given by the function  $h(t) = -16t^2 + kt + 3$ . If the maximum height of the arrow occurs at time  $t = 4$ , what is the value of  $k$ ?

- [A] 8            [B] 128        [C] 64        [D] 4

48. The height of an object,  $h(t)$ , is determined by the formula  $h(t) = -16t^2 + 256t$ , where  $t$  is time, in seconds. Will the object reach a maximum or a minimum? Explain or show your reasoning.

49. Vanessa throws a tennis ball in the air. The function  $h(t) = -16t^2 + 45t + 7$  represents the distance, in feet, that the ball is from the ground at any time  $t$ . At what time, to the nearest tenth of a second, is the ball at its maximum height?

50. The height,  $h$ , in feet, a ball will reach when thrown in the air is a function of time,  $t$ , in seconds, given by the equation  $h(t) = -16t^2 + 30t + 6$ . Find, to the nearest tenth, the maximum height, in feet, the ball will reach.

51. When a current,  $I$ , flows through a given electrical circuit, the power,  $W$ , of the circuit can be determined by the formula  $W = 120I - 12I^2$ . What amount of current,  $I$ , supplies the maximum power,  $W$ ?

52. The equation  $W = 120I - 12I^2$  represents the power ( $W$ ), in watts, of a 120-volt circuit having a resistance of 12 ohms when a current ( $I$ ) is flowing through the circuit. What is the maximum power, in watts, that can be delivered in this circuit?

53. A baseball player throws a ball from the outfield toward home plate. The ball's height above the ground is modeled by the equation  $y = -16x^2 + 48x + 6$  where  $y$  represents height, in feet, and  $x$  represents time, in seconds. The ball is initially thrown from a height of 6 feet. How many seconds after the ball is thrown will it again be 6 feet above the ground? What is the maximum height, in feet, that the ball reaches? [The use of the accompanying grid is optional.]

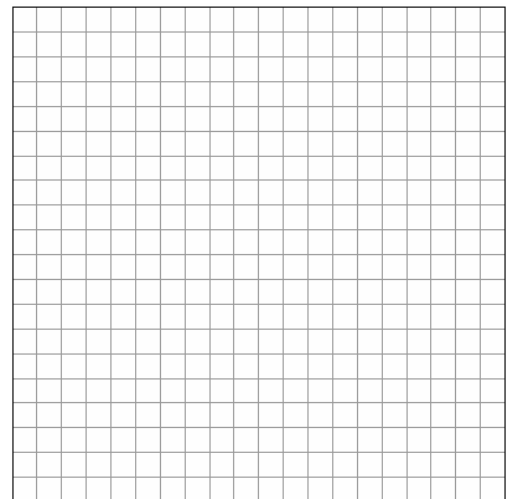



54. A rock is thrown vertically from the ground with a velocity of 24 meters per second, and it reaches a height of  $2 + 24t - 4.9t^2$  after  $t$  seconds. How many seconds after the rock is thrown will it reach maximum height, and what is the maximum height the rock will reach, in meters? How many seconds after the rock is thrown will it hit the ground? Round your answers to the *nearest hundredth*. [Only an algebraic or graphic solution will be accepted.]

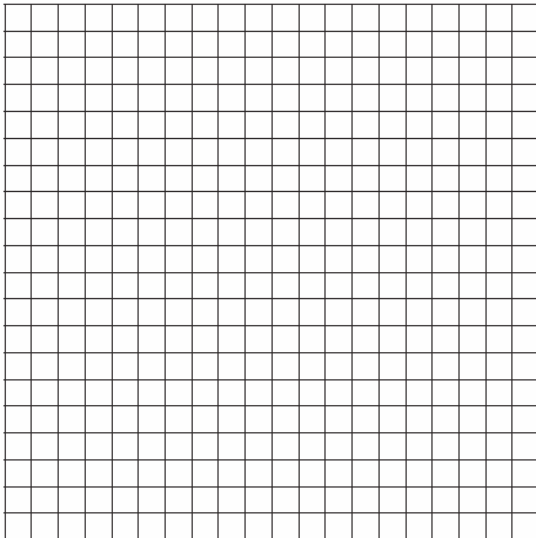

55. The path of a rocket fired during a fireworks display is given by the equation  $s(t) = 64t - 16t^2$ , where  $t$  is the time, in seconds, and  $s$  is the height, in feet. What is the maximum height, in feet, the rocket will reach? In how many seconds will the rocket hit the ground? [The grid is optional.]

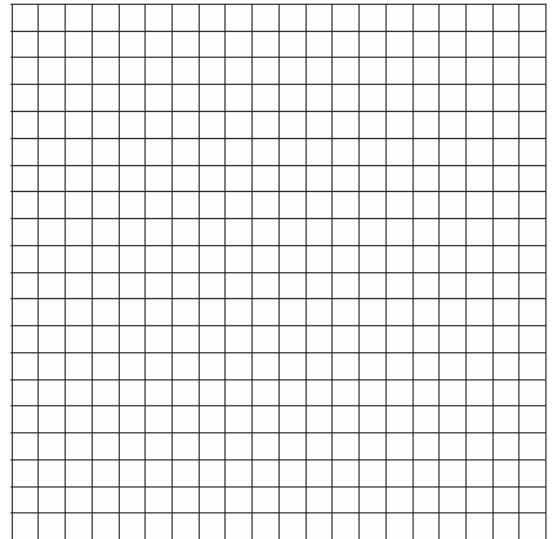

## CHAPTER 5-4

### INVERSE OF FUNCTIONS

56. If a function is defined by the equation  $y = 3x + 2$ , which equation defines the inverse of this function?
- [A]  $y = -3x - 2$       [B]  $y = \frac{1}{3}x + \frac{1}{2}$
- [C]  $y = \frac{1}{3}x - \frac{2}{3}$       [D]  $x = \frac{1}{3}y + \frac{1}{2}$
57. A function is defined by the equation  $y = 5x - 5$ . Which equation defines the inverse of this function?
- [A]  $y = \frac{1}{5x - 5}$       [B]  $x = 5y - 5$
- [C]  $y = 5x + 5$       [D]  $x = \frac{1}{5y - 5}$

58. A function is defined by the equation  $y = \frac{1}{2}x - \frac{3}{2}$ . Which equation defines the inverse of this function?

- [A]  $y = 2x - \frac{3}{2}$       [B]  $y = 2x + \frac{3}{2}$   
 [C]  $y = 2x - 3$       [D]  $y = 2x + 3$

59. Given:  $f(x) = x^2$  and  $g(x) = 2^x$   
 a The inverse of  $g$  is a function, but the inverse of  $f$  is not a function. Explain why this statement is true.  
 b Find  $g^{-1}(f(3))$  to the *nearest tenth*.

60. If the point  $(a, b)$  lies on the graph  $y = f(x)$ , the graph of  $y = f^{-1}(x)$  must contain point

- [A]  $(b, a)$       [B]  $(0, b)$   
 [C]  $(-a, -b)$       [D]  $(a, 0)$

61. Which graph represents the inverse of  $f(x) = \{(0,1), (1,4), (2,3)\}$ ?

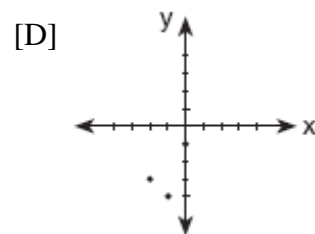
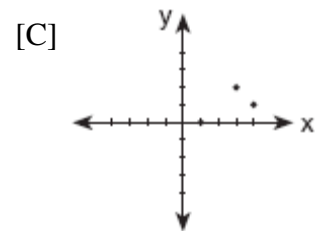
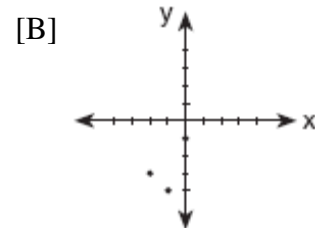
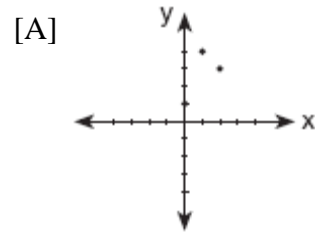

62. Draw  $f(x) = 2x^2$  and  $f^{-1}(x)$  in the interval  $0 \leq x \leq 2$  on the accompanying set of axes. State the coordinates of the points of intersection.

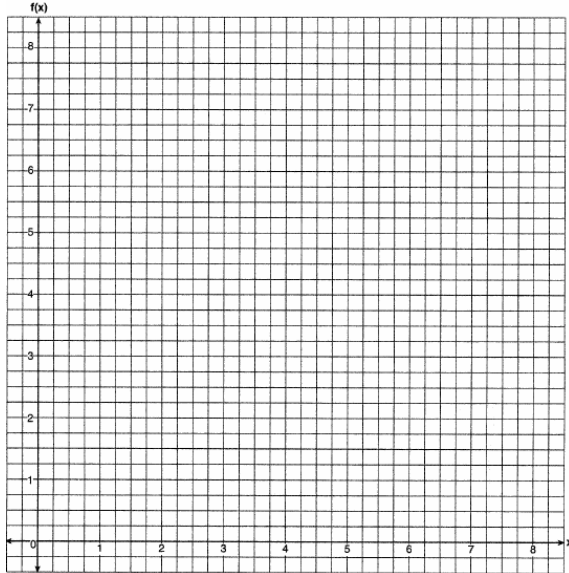

63. The accompanying diagram shows the graph of the line whose equation is  $y = -\frac{1}{3}x + 2$ . On the same set of axes, sketch the graph of the inverse of this function. State the coordinates of a point on the inverse function.

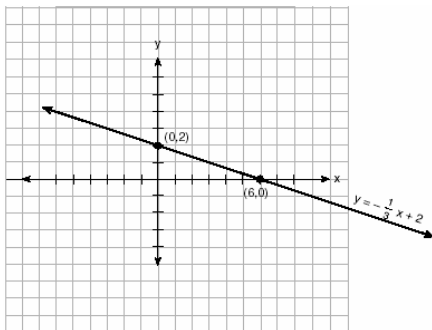

64. What is the inverse of the function  $y = \log_4 x$ ?
- [A]  $x^4 = y$                       [B]  $y^4 = x$   
[C]  $4^y = x$                         [D]  $4^x = y$

65. The inverse of a function is a logarithmic function in the form  $y = \log_b x$ . Which equation represents the original function?
- [A]  $y = bx$                         [B]  $x = b^y$   
[C]  $by = x$                         [D]  $y = b^x$

## CHAPTER 5-6

### IMAGINARY NUMBERS

66. The expression  $i^{25}$  is equivalent to  
[A]  $-i$     [B]  $i$     [C]  $1$     [D]  $-1$
67. Mrs. Donahue made up a game to help her class learn about imaginary numbers. The winner will be the student whose expression is equivalent to  $-i$ . Which expression will win the game?  
[A]  $i^{48}$     [B]  $i^{49}$     [C]  $i^{47}$     [D]  $i^{46}$
68. Expressed in simplest form,  $i^{16} + i^6 - 2i^5 + i^{13}$  is equivalent to  
[A]  $i$     [B]  $-1$     [C]  $1$     [D]  $-i$
69. When simplified,  $i^{27} + i^{34}$  is equal to  
[A]  $i-1$     [B]  $i$     [C]  $-i-1$     [D]  $i^{61}$
70. What is the value of  $i^{99} - i^3$ ?  
[A]  $i^{96}$     [B]  $1$     [C]  $-i$     [D]  $0$
71. What is the sum of  $\sqrt{-2}$  and  $\sqrt{-18}$ ?  
[A]  $5i\sqrt{2}$                               [B]  $6i$   
[C]  $4i\sqrt{2}$                                 [D]  $2i\sqrt{5}$
72. The expression  $i^0 \cdot i^1 \cdot i^2 \cdot i^3 \cdot i^4$  is equal to  
[A]  $i$     [B]  $1$     [C]  $-i$     [D]  $-1$

73. The expression  $\frac{i^{16}}{i^3}$  is equivalent to  
 [A] 1      [B]  $-i$       [C]  $i$       [D]  $-1$
74. What is the multiplicative inverse of  $3i$ ?  
 [A]  $-\frac{i}{3}$       [B]  $\frac{1}{3}$       [C]  $-3i$       [D]  $-3$

**COMPLEX NUMBERS**

75. Fractal geometry uses the complex number plane to draw diagrams, such as the one shown in the accompanying graph.

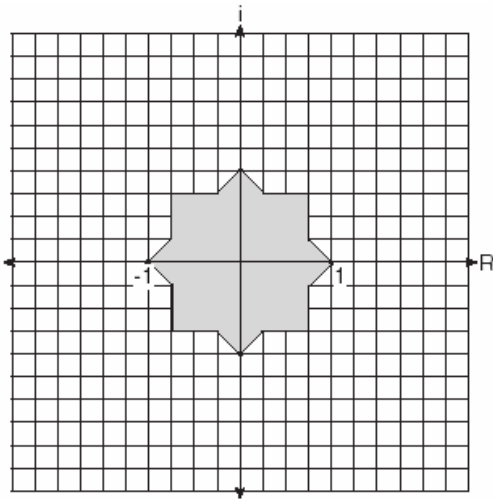

Which number is *not* included in the shaded area?

- [A]  $-0.9$       [B]  $-0.5i$   
 [C]  $-0.5 - 0.5i$       [D]  $-0.9 - 0.9i$

76. Two complex numbers are graphed below.

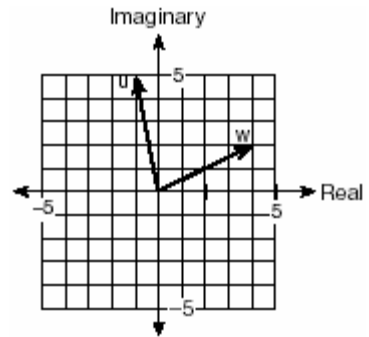

What is the sum of  $w$  and  $u$ , expressed in standard complex number form?

- [A]  $7 + 3i$       [B]  $5 + 7i$   
 [C]  $3 + 7i$       [D]  $-5 + 3i$
77. On a stamp honoring the German mathematician Carl Gauss, several complex numbers appear. The accompanying graph shows two of these numbers. Express the sum of these numbers in  $a + bi$  form.

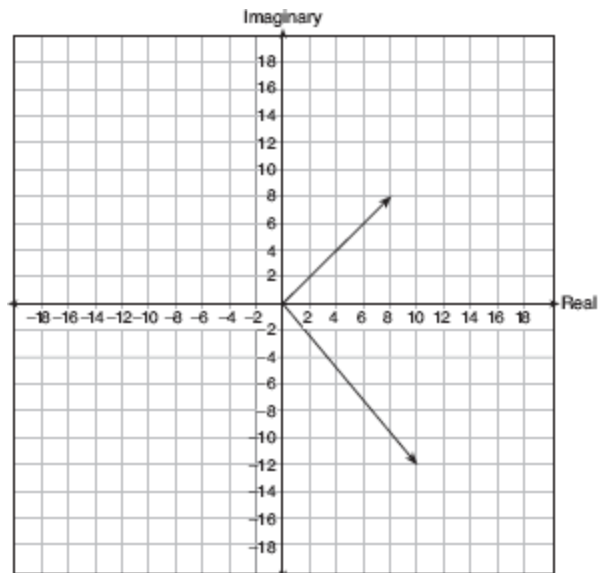

78. Find the sum of  $-2 + 3i$  and  $-1 - 2i$ .  
Graph the resultant on the accompanying set of axes.

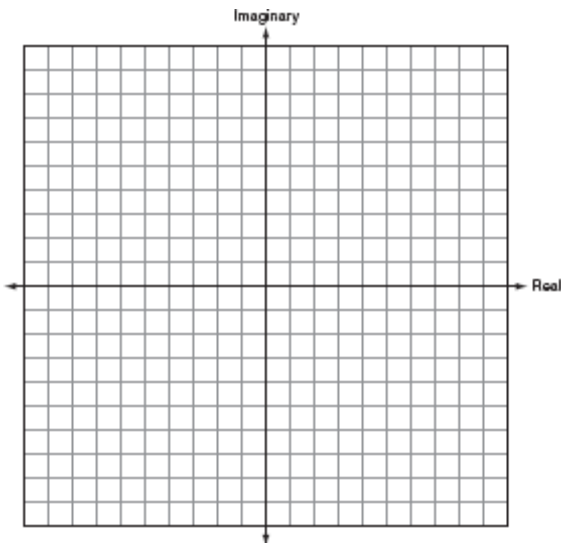

79. On the accompanying set of axes, graphically represent the sum of  $3 + 4i$  and  $-1 + 2i$ .

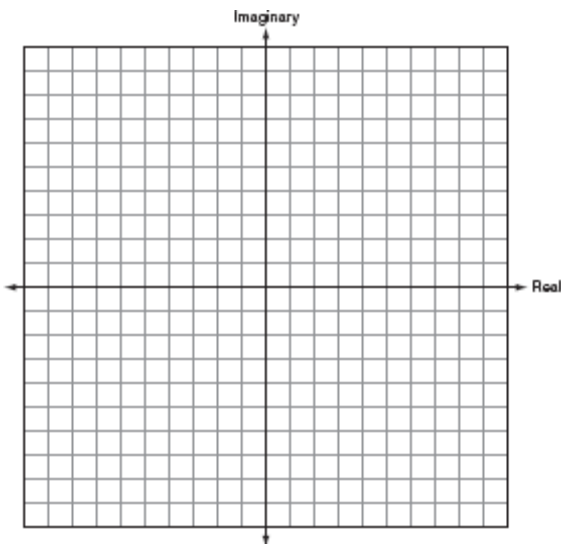

80. Melissa and Joe are playing a game with complex numbers. If Melissa has a score of  $5 - 4i$  and Joe has a score of  $3 + 2i$ , what is their total score?

- [A]  $8 - 6i$                       [B]  $8 + 6i$   
[C]  $8 - 2i$                       [D]  $8 + 2i$

81. Express  $\sqrt{-48} + 3.5 + \sqrt{25} + \sqrt{-27}$  in simplest  $a + bi$  form.
82. What is the sum of  $2 - \sqrt{-4}$  and  $-3 + \sqrt{-16}$  expressed in simplest  $a + bi$  form?  
[A]  $-1 + i\sqrt{20}$                       [B]  $-1 + 12i$   
[C]  $-1 + 2i$                               [D]  $-14 + i$
83. When expressed as a monomial in terms of  $i$ ,  $2\sqrt{-32} - 5\sqrt{-8}$  is equivalent to  
[A]  $18i\sqrt{2}$                               [B]  $2i\sqrt{2}$   
[C]  $2\sqrt{2}i$                                 [D]  $-2i\sqrt{2}$
84. What is the product of  $5 + \sqrt{-36}$  and  $1 - \sqrt{-49}$ , expressed in simplest  $a + bi$  form?  
[A]  $-37 + 41i$                               [B]  $47 - 29i$   
[C]  $5 - 71i$                                 [D]  $47 + 41i$
85. Show that the product of  $a + bi$  and its conjugate is a real number.
86. In an electrical circuit, the voltage,  $E$ , in volts, the current,  $I$ , in amps, and the opposition to the flow of current, called impedance,  $Z$ , in ohms, are related by the equation  $E = IZ$ . A circuit has a current of  $(3 + i)$  amps and an impedance of  $(-2 + i)$  ohms. Determine the voltage in  $a + bi$  form.
87. The relationship between voltage,  $E$ , current,  $I$ , and resistance,  $Z$ , is given by the equation  $E = IZ$ . If a circuit has a current  $I = 3 + 2i$  and a resistance  $Z = 2 - i$ , what is the voltage of this circuit?  
[A]  $4 + i$     [B]  $8 + i$     [C]  $8 + 7i$     [D]  $4 - i$
88. The complex number  $c + di$  is equal to  $(2 + i)^2$ . What is the value of  $c$ ?

89. The expression  $(-1+i)^3$  is equivalent to  
 [A]  $-3i$  [B]  $2+2i$   
 [C]  $-1-i$  [D]  $-2-2i$
90. If  $f(x) = x^3 - 2x^2$ , then  $f(i)$  is equivalent to  
 [A]  $2+i$  [B]  $-2+i$  [C]  $2-i$  [D]  $-2-i$
91. What is the value of  $x$  in the equation  
 $\sqrt{5-2x} = 3i$ ?  
 [A] 1 [B] 7 [C] 4 [D] -2
92. The expression  $\frac{2+i}{3+i}$  is equivalent to  
 [A]  $\frac{7+i}{10}$  [B]  $\frac{7-5i}{10}$   
 [C]  $\frac{6+i}{8}$  [D]  $\frac{6+5i}{8}$
93. Impedance measures the opposition of an electrical circuit to the flow of electricity. The total impedance in a particular circuit is given by the formula  $Z_T = \frac{Z_1 Z_2}{Z_1 + Z_2}$ . What is the total impedance of a circuit,  $Z_T$ , if  $Z_1 = 1+2i$  and  $Z_2 = 1-2i$ ?  
 [A]  $-\frac{3}{2}$  [B] 0 [C]  $\frac{5}{2}$  [D] 1
95. Barb pulled the plug in her bathtub and it started to drain. The amount of water in the bathtub as it drains is represented by the equation  $L = -5t^2 - 8t + 120$ , where  $L$  represents the number of liters of water in the bathtub and  $t$  represents the amount of time, in minutes, since the plug was pulled. How many liters of water were in the bathtub when Barb pulled the plug? Show your reasoning.  
 Determine, to the *nearest tenth of a minute*, the amount of time it takes for all the water in the bathtub to drain.
96. Matt's rectangular patio measures 9 feet by 12 feet. He wants to increase the patio's dimensions so its area will be twice the area it is now. He plans to increase both the length and the width by the same amount,  $x$ . Find  $x$ , to the *nearest hundredth of a foot*.
97. If  $2 + 3i$  is one root of a quadratic equation with real coefficients, what is the sum of the roots of the equation?
98. Express, in simplest  $a + bi$  form, the roots of the equation  $x^2 + 5 = 4x$ .
99. Solve for  $x$  in simplest  $a + bi$  form:  
 $x^2 + 8x + 25 = 0$
100. In physics class, Taras discovers that the behavior of electrical power,  $x$ , in a particular circuit can be represented by the function  $f(x) = x^2 + 2x + 7$ . If  $f(x) = 0$ , solve the equation and express your answer in simplest  $a + bi$  form.
101. Which quadratic equation has the roots  $3+i$  and  $3-i$ ?  
 [A]  $x^2 - 6x - 8 = 0$  [B]  $x^2 + 6x - 10 = 0$   
 [C]  $x^2 + 6x + 8 = 0$  [D]  $x^2 - 6x + 10 = 0$

## CHAPTER 5-8

### QUADRATICS WITH NONINTEGER SOLUTIONS

94. If the sum of the roots of  $x^2 + 3x - 5$  is added to the product of its roots, the result is  
 [A] 15 [B] -15 [C] -2 [D] -8

102. If  $2 + i$  and  $2 - i$  are the roots of the equation  $x^2 - 4x + c = 0$ , what is the value of  $c$ ?  
[A] 4      [B] 5      [C] -4      [D] -5

109. The roots of the equation  $2x^2 - 5 = 0$  are  
[A] real, rational, and unequal  
[B] imaginary      [C] real and irrational  
[D] real, rational, and equal

**USING THE DISCRIMINANT**

103. The roots of a quadratic equation are real, rational, and equal when the discriminant is  
[A] 0      [B] 2      [C] -2      [D] 4

110. Which equation has imaginary roots?  
[A]  $x^2 - 1 = 0$       [B]  $x^2 - x - 1 = 0$   
[C]  $x^2 + x + 1 = 0$       [D]  $x^2 - 2 = 0$

104. Which number is the discriminant of a quadratic equation whose roots are real, unequal, and irrational?  
[A] 7      [B] 4      [C] -5      [D] 0

111. Which equation has imaginary roots?  
[A]  $(2x + 1)(x - 3) = 7$       [B]  $x(x + 6) = -10$   
[C]  $x(5 - x) = -3$       [D]  $x(5 + x) = 8$

105. Jacob is solving a quadratic equation. He executes a program on his graphing calculator and sees that the roots are real, rational, and unequal. This information indicates to Jacob that the discriminant is  
[A] zero      [B] a perfect square  
[C] not a perfect square      [D] negative

112. For which positive value of  $m$  will the equation  $4x^2 + mx + 9 = 0$  have roots that are real, equal, and rational?  
[A] 12      [B] 9      [C] 3      [D] 4

106. The roots of the equation  $x^2 - 3x - 2 = 0$  are  
[A] imaginary  
[B] real, rational, and equal  
[C] real, rational, and unequal  
[D] real, irrational, and unequal

113. The roots of the equation  $ax^2 + 4x = -2$  are real, rational, and equal when  $a$  has a value of  
[A] 3      [B] 1      [C] 2      [D] 4

107. The roots of the equation  $2x^2 - 8x - 4 = 0$  are  
[A] real, irrational, and unequal  
[B] real, rational, and unequal  
[C] real, rational, and equal  
[D] imaginary

114. In the equation  $ax^2 + 6x - 9 = 0$ , imaginary roots will be generated if  
[A]  $-1 < a < 1$       [B]  $a < -1$   
[C]  $a > -1$ , only      [D]  $a < 1$ , only

108. The roots of the equation  $2x^2 - x = 4$  are  
[A] real, rational, and unequal  
[B] real and irrational      [C] imaginary  
[D] real, rational, and equal

115. The equation  $2x^2 + 8x + n = 0$  has imaginary roots when  $n$  is equal to  
[A] 6      [B] 8      [C] 10      [D] 4
116. Find all values of  $k$  such that the equation  $3x^2 - 2x + k = 0$  has imaginary roots.
117. Given the function  $y = f(x)$ , such that the entire graph of the function lies above the  $x$ -axis. Explain why the equation  $f(x) = 0$  has no real solutions.

118. Which statement must be true if a parabola represented by the equation  $y = ax^2 + bx + c$  does not intersect the  $x$ -axis?
- [A]  $b^2 - 4ac > 0$ , and  $b^2 - 4ac$  is not a perfect square.  
 [B]  $b^2 - 4ac = 0$       [C]  $b^2 - 4ac < 0$   
 [D]  $b^2 - 4ac > 0$ , and  $b^2 - 4ac$  is a perfect square.
119. If the roots of  $ax^2 + bx + c = 0$  are real, rational, and equal, what is true about the graph of the function  $y = ax^2 + bx + c$ ?
- [A] It lies entirely below the  $x$ -axis.  
 [B] It is tangent to the  $x$ -axis.  
 [C] It intersects the  $x$ -axis in two distinct points.  
 [D] It lies entirely above the  $x$ -axis.
120. Which is a true statement about the graph of the equation  $y = x^2 - 7x - 60$ ?
- [A] It intersects the  $x$ -axis in two distinct points that have irrational coordinates.  
 [B] It does not intersect the  $x$ -axis.  
 [C] It is tangent to the  $x$ -axis.  
 [D] It intersects the  $x$ -axis in two distinct points that have rational coordinates.

121. Which graph represents a quadratic function with a negative discriminant?

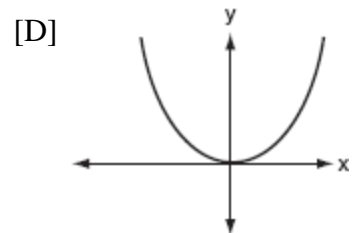
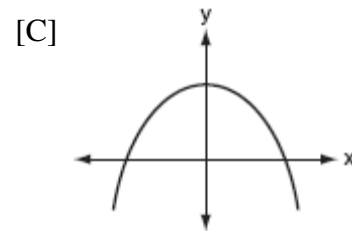
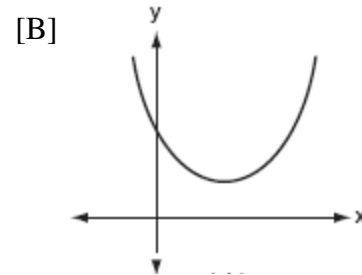
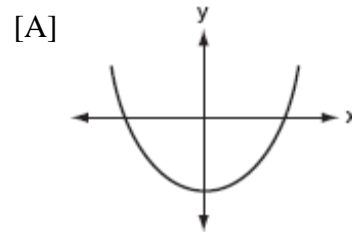

## NY LESSON 2

### QUADRATIC INEQUALITIES

122. Which graph represents the solution set of the inequality  $x^2 - 4x - 5 < 0$ ?

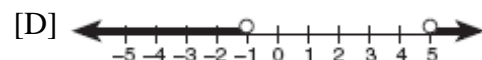
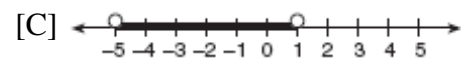
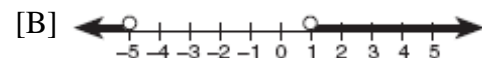
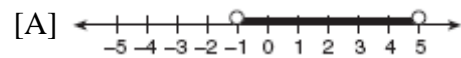



123. Which graph represents the solution set of  $x^2 - x - 12 < 0$ ?

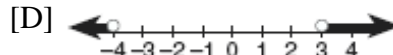
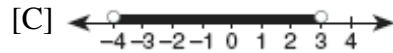
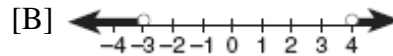
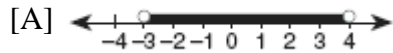

124. When a baseball is hit by a batter, the height of the ball,  $h(t)$ , at time  $t$ ,  $t \geq 0$ , is determined by the equation  $h(t) = -16t^2 + 64t + 4$ . For which interval of time is the height of the ball greater than or equal to 52 feet?

125. The height of a projectile is modeled by the equation  $y = -2x^2 + 38x + 10$ , where  $x$  is time, in seconds, and  $y$  is height, in feet. During what interval of time, to the *nearest tenth of a second*, is the projectile *at least* 125 feet above ground? [The use of the accompanying grid is optional.]

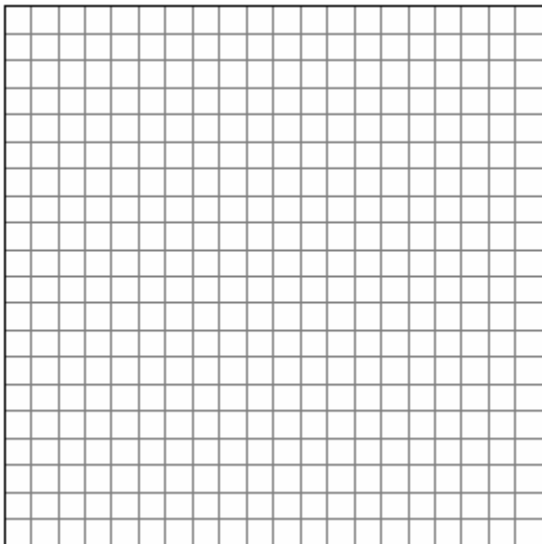

126. The profit a coat manufacturer makes each day is modeled by the equation  $P(x) = -x^2 + 120x - 2000$ , where  $P$  is the profit and  $x$  is the price for each coat sold. For what values of  $x$  does the company make a profit? [The use of the accompanying grid is optional.]

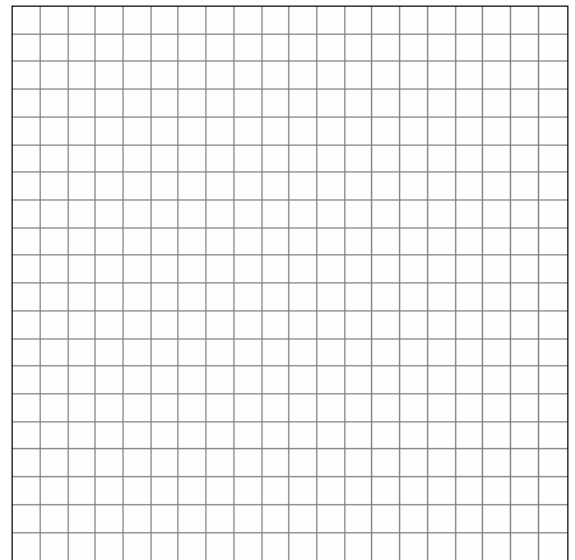

127. The profit,  $P$ , for manufacturing a wireless device is given by the equation  $P = -10x^2 + 750x - 9,000$ , where  $x$  is the selling price, in dollars, for each wireless device. What range of selling prices allows the manufacturer to make a profit on this wireless device? [The use of the grid is optional.]

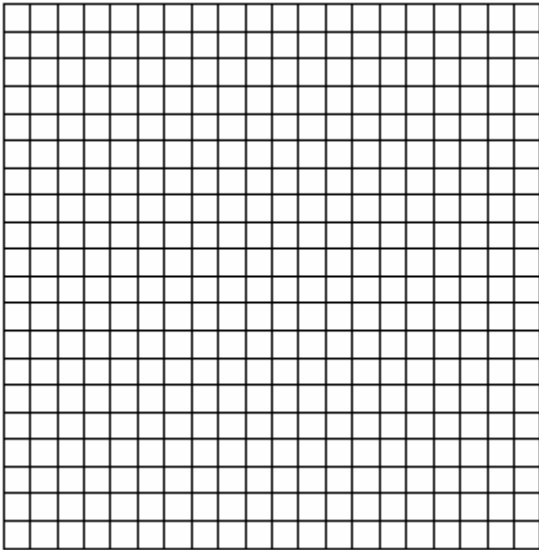

131. If  $x$  is a positive integer,  $4x^{\frac{1}{2}}$  is equivalent to  
[A]  $\frac{2}{x}$  [B]  $4\frac{1}{x}$  [C]  $2x$  [D]  $4\sqrt{x}$

132. The expression  $b^{-\frac{3}{2}}$ ,  $b > 0$ , is equivalent to  
[A]  $\frac{1}{(\sqrt[3]{b})^2}$  [B]  $-(\sqrt{b})^3$   
[C]  $(\sqrt[3]{b})^2$  [D]  $\frac{1}{(\sqrt{b})^3}$

133. The volume of a soap bubble is represented by the equation  $V = 0.094\sqrt{A^3}$ , where  $A$  represents the surface area of the bubble. Which expression is also equivalent to  $V$ ?

- [A]  $0.094A^6$  [B]  $0.094A^{\frac{2}{3}}$   
[C]  $0.094A^{\frac{3}{2}}$  [D]  $(0.094A^3)^{\frac{1}{2}}$

134. The expression  $\sqrt[4]{16a^6b^4}$  is equivalent to

- [A]  $4a^{\frac{3}{2}}b$  [B]  $2a^2b$   
[C]  $4a^2b$  [D]  $2a^{\frac{3}{2}}b$

135. When simplified, the expression  $(\sqrt[3]{m^4})(m^{-\frac{1}{2}})$  is equivalent to

- [A]  $\sqrt[6]{m^5}$  [B]  $\sqrt[4]{m^3}$   
[C]  $\sqrt[5]{m^{-4}}$  [D]  $\sqrt[3]{m^{-2}}$

136. Find the value of  $(x+2)^0 + (x+1)^{-\frac{2}{3}}$  when  $x = 7$ .

137. If  $f(x) = x^{\frac{3}{2}}$ , then  $f(\frac{1}{4})$  is equal to

- [A]  $-2$  [B]  $-4$  [C]  $-\frac{1}{8}$  [D]  $8$

## CHAPTER 6-1

### EXPONENTS AS RADICALS

128. The expression  $4^{\frac{1}{2}} \cdot 2^3$  is equal to

- [A]  $4^{\frac{3}{2}}$  [B]  $4$  [C]  $16$  [D]  $8^{\frac{3}{2}}$

129. The expression  $\frac{3^{\frac{1}{3}}}{3^{\frac{2}{3}}}$  is equivalent to

- [A]  $\sqrt{3}$  [B]  $\frac{1}{\sqrt[3]{3}}$  [C]  $3$  [D]  $1$

130. The value of  $(\frac{3^0}{27^{\frac{2}{3}}})^{-1}$  is

- [A]  $\frac{1}{9}$  [B]  $-\frac{1}{9}$  [C]  $9$  [D]  $-9$

138. If  $(a^x)^{\frac{2}{3}} = \frac{1}{a^2}$ , what is the value of  $x$ ?

- [A] -1      [B] 2      [C] -3      [D] 1

139. Meteorologists can determine how long a storm lasts by using the function

$t(d) = 0.07d^{\frac{3}{2}}$ , where  $d$  is the diameter of the storm, in miles, and  $t$  is the time, in hours. If the storm lasts 4.75 hours, find its diameter, to the *nearest tenth of a mile*.

142. What is the middle term in the expansion of  $(x + y)^4$ ?

- [A]  $2x^2y^2$       [B]  $4x^2y^2$   
[C]  $6x^2y^2$       [D]  $x^2y^2$

143. What is the fourth term in the expansion of  $(y - 1)^7$ ?

- [A]  $35y^4$       [B]  $-35y^3$   
[C]  $-35y^4$       [D]  $35y^3$

144. What is the fourth term in the expansion of  $(2x - y)^5$ ?

145. What is the third term in the expansion of  $\ln(\cos x + 3)^5$ ?

- [A]  $90\cos^2 x$       [B]  $270\cos^2 x$   
[C]  $60\cos^3 x$       [D]  $90\cos^3 x$

## CHAPTER 6-2

### REGRESSION

140. The accompanying table shows the number of new cases reported by the Nassau and Suffolk County Police Crime Stoppers program for the years 2000 through 2002.

Year ( $x$ )	New Cases ( $y$ )
2000	457
2001	369
2002	353

If  $x = 1$  represents the year 2000, and  $y$  represents the number of new cases, find the equation of best fit using a power regression, rounding all values to the *nearest thousandth*. Using this equation, find the estimated number of new cases, to the *nearest whole number*, for the year 2007.

### BINOMIAL PROBABILITY

146. The probability that Kyla will score above a 90 on a mathematics test is  $\frac{4}{5}$ . What is the probability that she will score above a 90 on three of the four tests this quarter?

- [A]  ${}_4C_3\left(\frac{4}{5}\right)^3\left(\frac{1}{5}\right)^1$       [B]  ${}_4C_3\left(\frac{4}{5}\right)^1\left(\frac{1}{5}\right)^3$   
[C]  $\frac{3}{4}\left(\frac{4}{5}\right)^3\left(\frac{1}{5}\right)^1$       [D]  $\frac{3}{4}\left(\frac{4}{5}\right)^1\left(\frac{1}{5}\right)^3$

147. The Hiking Club plans to go camping in a State park where the probability of rain on any given day is 0.7. Which expression can be used to find the probability that it will rain on *exactly* three of the seven days they are there?

- [A]  ${}_4C_3(0.7)^3(0.7)^4$       [B]  ${}_7C_3(0.3)^3(0.7)^4$   
[C]  ${}_4C_3(0.4)^4(0.3)^3$       [D]  ${}_7C_3(0.7)^3(0.3)^4$

## CHAPTER 6-7

### BINOMIAL EXPANSIONS

141. What is the *last* term in the expansion of  $(x + 2y)^5$ ?

- [A]  $2y^5$       [B]  $10y^5$       [C]  $32y^5$       [D]  $y^5$

148. During a single day at radio station WMZH, the probability that a particular song is played is .38. Which expression represents the probability that this song will be played on *exactly* 5 days out of 7 days?

[A]  ${}_7P_5(.38)^5(.62)^2$       [B]  ${}_7C_5(.38)^5(.62)^2$   
 [C]  ${}_5C_2(.38)^5(.62)^2$       [D]  ${}_7C_5(.38)^2(.62)^5$

149. Which fraction represents the probability of obtaining *exactly* eight heads in ten tosses of a fair coin?

[A]  $\frac{45}{1,024}$       [B]  $\frac{90}{1,024}$   
 [C]  $\frac{180}{1,024}$       [D]  $\frac{64}{1,024}$

150. At a certain intersection, the light for eastbound traffic is red for 15 seconds, yellow for 5 seconds, and green for 30 seconds. Find, to the *nearest tenth*, the probability that out of the next eight eastbound cars that arrive randomly at the light, exactly three will be stopped by a red light.

151. After studying a couple's family history, a doctor determines that the probability of any child born to this couple having a gene for disease X is 1 out of 4. If the couple has three children, what is the probability that *exactly* two of the children have the gene for disease X?

152. If the probability that it will rain on any given day this week is 60%, find the probability it will rain *exactly* 3 out of 7 days this week.

153. The Coolidge family's favorite television channels are 3, 6, 7, 10, 11, and 13. If the Coolidge family selects a favorite channel at random to view each night, what is the probability that they choose *exactly* three even-numbered channels in five nights? Express your answer as a fraction or as a decimal rounded to *four decimal places*.

154. During a recent survey, students at Franconia College were asked if they drink coffee in the morning. The results showed that two-thirds of the students drink coffee in the morning and the remainder do not. What is the probability that of six students selected at random, *exactly* two of them drink coffee in the morning? Express your answer as a fraction or as a decimal rounded to *four decimal places*.

155. Ginger and Mary Anne are planning a vacation trip to the island of Capri, where the probability of rain on any day is 0.3. What is the probability that during their five days on the island, they have *no* rain on *exactly* three of the five days?

156. As shown in the accompanying diagram, a circular target with a radius of 9 inches has a bull's-eye that has a radius of 3 inches. If five arrows randomly hit the target, what is the probability that *at least* four hit the bull's-eye?

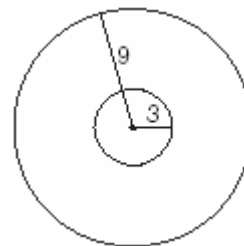

157. Team A and team B are playing in a league. They will play each other five times. If the probability that team A wins a game is  $\frac{1}{3}$ , what is the probability that team A will win *at least* three of the five games?
158. On any given day, the probability that the entire Watson family eats dinner together is  $\frac{2}{5}$ . Find the probability that, during any 7-day period, the Watsons eat dinner together *at least* six times.

## MATH TOOLBOX P. 311

### REGRESSION

159. Tim Parker, a star baseball player, hits one home run for every ten times he is at bat. If Parker goes to bat five times during tonight's game, what is the probability that he will hit *at least* four home runs?
160. The probability that a planted watermelon seed will sprout is  $\frac{3}{4}$ . If Peyton plants seven seeds from a slice of watermelon, find, to the *nearest ten thousandth*, the probability that *at least* five will sprout.
161. On mornings when school is in session in January, Sara notices that her school bus is late one-third of the time. What is the probability that during a 5-day school week in January her bus will be late *at least* three times?
162. A board game has a spinner on a circle that has five equal sectors, numbered 1, 2, 3, 4, and 5, respectively. If a player has four spins, find the probability that the player spins an even number *no more than* two times on those four spins.
163. Dr. Glendon, the school physician in charge of giving sports physicals, has compiled his information and has determined that the probability a student will be on a team is 0.39. Yesterday, Dr. Glendon examined five students chosen at random.  
Find, to the *nearest hundredth*, the probability that at least four of the five students will be on a team.  
Find, to the *nearest hundredth*, the probability that exactly one of the five students will not be on a team.
164. When Joe bowls, he can get a strike (knock down all the pins) 60% of the time. How many times more likely is it for Joe to bowl *at least* three strikes out of four tries as it is for him to bowl zero strikes out of four tries? Round your answer to the *nearest whole number*.

165. A box containing 1,000 coins is shaken, and the coins are emptied onto a table. Only the coins that land heads up are returned to the box, and then the process is repeated. The accompanying table shows the number of trials and the number of coins returned to the box after each trial.

Trial	0	1	3	4	6
Coins Returned	1,000	610	220	132	45

Write an exponential regression equation, rounding the calculated values to the *nearest ten-thousandth*.

Use the equation to predict how many coins would be returned to the box after the eighth trial.

166. The table below, created in 1996, shows a history of transit fares from 1955 to 1995. On the accompanying grid, construct a scatter plot where the independent variable is years. State the exponential regression equation with the coefficient and base rounded to the *nearest thousandth*. Using this equation, determine the prediction that should have been made for the year 1998, to the *nearest cent*.

Year	Fare (\$)
55	0.10
60	0.15
65	0.20
70	0.30
75	0.40
80	0.60
85	0.80
90	1.15
95	1.50

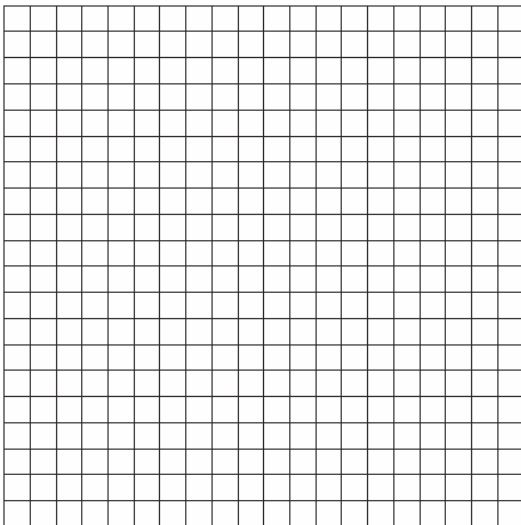

167. The breaking strength,  $y$ , in tons, of steel cable with diameter  $d$ , in inches, is given in the table below.

$d$ (in)	$y$ (tons)
0.50	9.85
0.75	21.80
1.00	38.30
1.25	59.20
1.50	84.40
1.75	114.00

On the accompanying grid, make a scatter plot of these data. Write the exponential regression equation, expressing the regression coefficients to the *nearest tenth*.

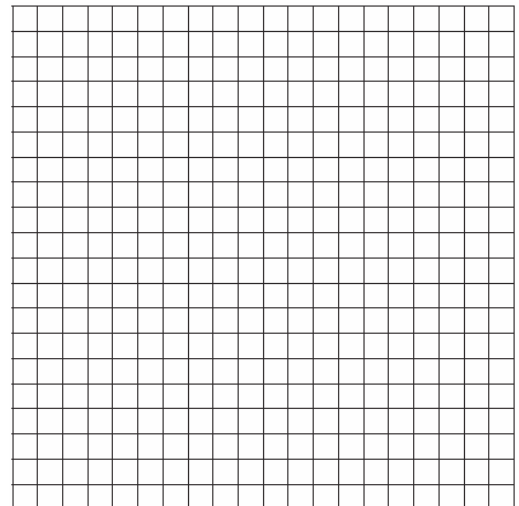

168. The accompanying table shows the average salary of baseball players since 1984. Using the data in the table, create a scatter plot on the grid and state the exponential regression equation with the coefficient and base rounded to the *nearest hundredth*. Using your written regression equation, estimate the salary of a baseball player in the year 2005, to the *nearest thousand dollars*.

Baseball Players' Salaries

Numbers of Years Since 1984	Average Salary (thousands of dollars)
0	290
1	320
2	400
3	495
4	600
5	700
6	820
7	1,000
8	1,250
9	1,580

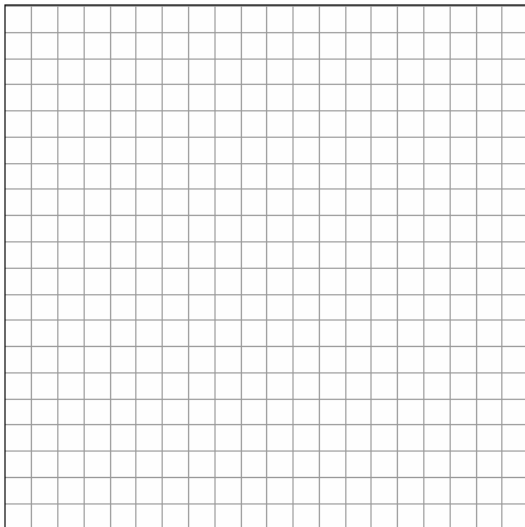

169. Jean invested \$380 in stocks. Over the next 5 years, the value of her investment grew, as shown in the accompanying table.

Years Since Investment ( $x$ )	Value of Stock, in Dollars ( $y$ )
0	380
1	395
2	411
3	427
4	445
5	462

Write the exponential regression equation for this set of data, rounding all values to *two decimal places*. Using this equation, find the value of her stock, to the *nearest dollar*, 10 years after her initial purchase.

## CHAPTER 7-2

### EXPONENTIAL FUNCTIONS

170. Which equation models the data in the accompanying table?

Time in hours, $x$	0	1	2	3	4	5	6
Population, $y$	5	10	20	40	80	160	320

- [A]  $y = 2x$                       [B]  $y = 2^x$   
 [C]  $y = 5(2^x)$                 [D]  $y = 2x + 5$

171. What is the domain of  $f(x) = 2^x$ ?

- [A]  $x \leq 0$                       [B] all real numbers  
 [C]  $x \geq 0$                       [D] all integers

172. A population of wolves in a county is represented by the equation  $P(t) = 80(0.98)^t$ , where  $t$  is the number of years since 1998. Predict the number of wolves in the population in the year 2008.

173. The height,  $f(x)$ , of a bouncing ball after  $x$  bounces is represented by  $f(x) = 80(0.5)^x$ . How many times higher is the first bounce than the fourth bounce?

[A] 8      [B] 4      [C] 16      [D] 2

174. The accompanying graph represents the value of a bond over time.

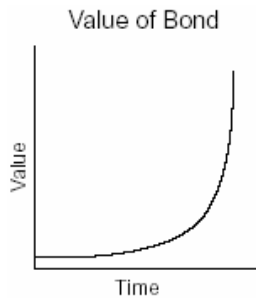

Which type of function does this graph best model?

[A] quadratic                      [B] trigonometric  
[C] exponential                  [D] logarithmic

175. The strength of a medication over time is represented by the equation  $y = 200(1.5)^{-x}$ , where  $x$  represents the number of hours since the medication was taken and  $y$  represents the number of micrograms per millimeter left in the blood. Which graph best represents this relationship?

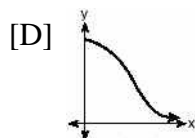
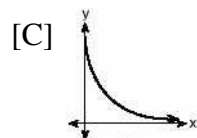
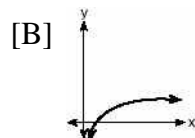
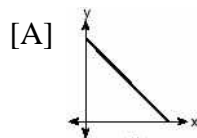

176. Which equation best represents the accompanying graph?

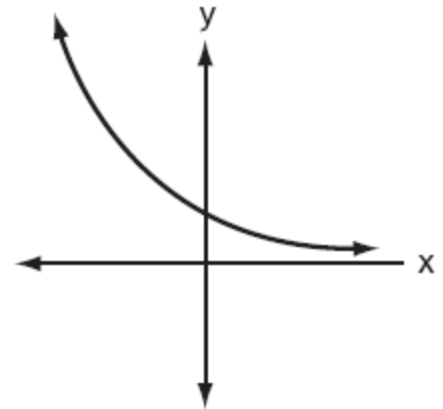

[A]  $y = 2^x$                       [B]  $y = 2^{-x}$   
[C]  $y = x^2 + 2$               [D]  $y = -2^x$

177. On January 1, 1999, the price of gasoline was \$1.39 per gallon. If the price of gasoline increased by 0.5% per month, what was the cost of one gallon of gasoline, to the *nearest cent*, on January 1 one year later?

178. A used car was purchased in July 1999 for \$11,900. If the car depreciates 13% of its value each year, what is the value of the car, to the *nearest hundred dollars*, in July 2002?

179. The Franklins inherited \$3,500, which they want to invest for their child's future college expenses. If they invest it at 8.25% with interest compounded monthly, determine the value of the account, in dollars, after 5 years.

Use the formula  $A = P\left(1 + \frac{r}{n}\right)^{nt}$ , where  $A =$  value of the investment after  $t$  years,  $P =$  principal invested,  $r =$  annual interest rate, and  $n =$  number of times compounded per year.



**SOLVING NONLINEAR SYSTEMS**

180. The graphs of the equations  $y = 2^x$  and  $y = -2x + a$  intersect in Quadrant I for which values of  $a$ ?

- [A]  $a > 1$                       [B]  $a < 1$   
[C]  $a \geq 1$                       [D]  $0 < a < 1$

181. On the accompanying grid, sketch the graphs of  $y = 2^x$  and  $3y = 7x + 3$  over the interval  $-3 \leq x \leq 4$ . Identify and state the coordinates of all points of intersection.

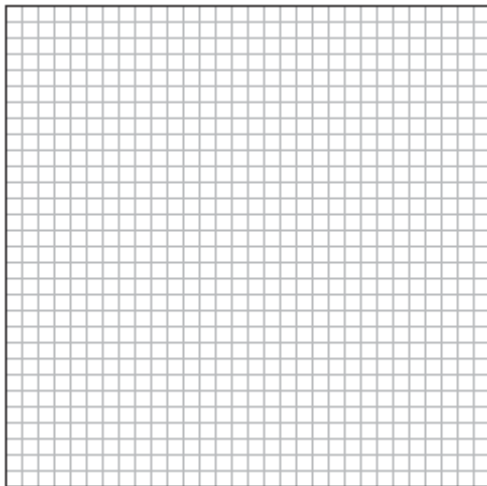

182. On the accompanying grid, solve the following system of equations graphically:

$$y = -x^2 + 2x + 1$$

$$y = 2^x$$

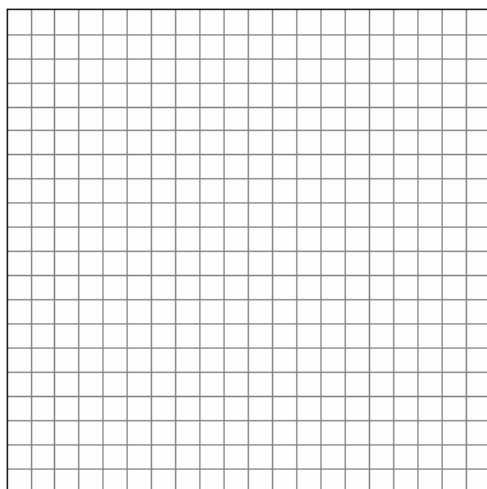

**CHAPTER 7-3**

**GRAPHING LOGARITHMIC FUNCTIONS**

183. The cells of a particular organism increase logarithmically. If  $g$  represents cell growth and  $h$  represents time, in hours, which graph best represents the growth pattern of the cells of this organism?

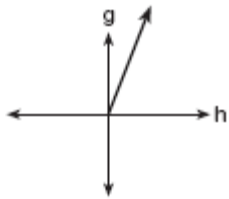
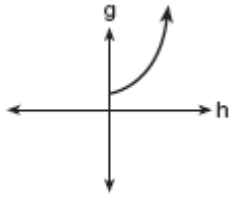
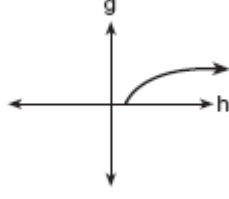
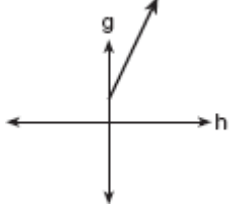
- [A] 
- [B] 
- [C] 
- [D] 



195. The speed of sound,  $v$ , at temperature  $T$ , in degrees Kelvin, is represented by the equation

$v = 1087\sqrt{\frac{T}{273}}$ . Which expression is equivalent to  $\log v$ ?

[A]  $\log 1087 + \frac{1}{2}\log T - \frac{1}{2}\log 273$

[B]  $1087(\frac{1}{2}\log T - \frac{1}{2}\log 273)$

[C]  $\log 1087 + 2\log(T + 273)$

[D]  $1087 + \frac{1}{2}\log T - \log 273$

196. A black hole is a region in space where objects seem to disappear. A formula used in the study of black holes is the Schwarzschild formula,  $R = \frac{2GM}{c^2}$ .

Based on the laws of logarithms,  $\log R$  can be represented by

[A]  $\log 2 + \log G + \log M - 2\log c$

[B]  $2\log G + \log M - \log 2c$

[C]  $\log 2G + \log M - \log 2c$

[D]  $2\log GM - 2\log c$

## CHAPTER 7-4

### LOGARITHMIC EQUATIONS

197. Solve for  $x$ :  $\log_4(x^2 + 3x) - \log_4(x + 5) = 1$

198. In the equation  $\log_x 4 + \log_x 9 = 2$ ,  $x$  is equal to

[A]  $\sqrt{13}$  [B] 6 [C] 18 [D] 6.5

199. If  $\log_5 x = 2$ , what is the value of  $\sqrt{x}$ ?

[A] 25 [B]  $2^{\frac{2}{5}}$  [C] 5 [D]  $\sqrt{5}$

200. Solve for  $x$ :  $\log_2(x + 1) = 3$

201. Solve for  $x$ :  $\log_b 36 - \log_b 2 = \log_b x$

202. If  $\log k = c\log v + \log p$ ,  $k$  equals

[A]  $v^c p$  [B]  $(vp)^c$

[C]  $v^c + p$  [D]  $cv + p$

203. The relationship between the relative size of an earthquake,  $S$ , and the measure of the earthquake on the Richter scale,  $R$ , is given by the equation  $\log S = R$ . If an earthquake measured 3.2 on the Richter scale, what was its relative size to the *nearest hundredth*?

204. The magnitude ( $R$ ) of an earthquake is related to its intensity ( $I$ ) by  $R = \log\left(\frac{I}{T}\right)$ , where  $T$  is

the threshold below which the earthquake is not noticed. If the intensity is doubled, its magnitude can be represented by

[A]  $2(\log I - \log T)$  [B]  $2\log I - \log T$

[C]  $\log 2 + \log I - \log T$  [D]  $\log I - \log T$

205. The scientists in a laboratory company raise amebas to sell to schools for use in biology classes. They know that one ameba divides into two amebas every hour and that the formula  $t = \log_2 N$  can be used to determine how long in hours,  $t$ , it takes to produce a certain number of amebas,  $N$ . Determine, to the *nearest tenth of an hour*, how long it takes to produce 10,000 amebas if they start with one ameba.

## CHAPTER 7-5

### EXPONENTIAL EQUATIONS

206. The solution set of  $2^{x^2+2x} = 2^{-1}$  is

[A] {1} [B] {} [C] {-1} [D] {-1, 1}

207. What is the value of  $b$  in the equation

$$4^{2b-3} = 8^{1-b} ?$$

- [A]  $\frac{10}{7}$     [B]  $\frac{-3}{7}$     [C]  $\frac{9}{7}$     [D]  $\frac{7}{9}$

208. Solve algebraically for  $x$ :  $8^{2x} = 4^6$

209. What is the value of  $x$  in the equation

$$81^{x+2} = 27^{5x+4} ?$$

- [A]  $-\frac{3}{2}$     [B]  $-\frac{4}{11}$     [C]  $\frac{4}{11}$     [D]  $-\frac{2}{11}$

210. Solve algebraically for  $x$ :  $27^{2x+1} = 9^{4x}$

211. Solve for  $m$ :  $3^{m+1} - 5 = 22$

212. Determine the value of  $x$  and  $y$  if  $2^y = 8^x$  and  $3^y = 3^{x+4}$ .

- [A]  $x = -2, y = -6$     [B]  $x = 6, y = 2$   
 [C]  $x = 2, y = 6$     [D]  $x = y$

213. The growth of bacteria in a dish is modeled by the function  $f(t) = 2^{\frac{t}{3}}$ . For which value of  $t$  is  $f(t) = 32$ ?

- [A] 8    [B] 16    [C] 15    [D] 2

214. Growth of a certain strain of bacteria is modeled by the equation  $G = A(2.7)^{0.584t}$ , where:

- $G$  = final number of bacteria  
 $A$  = initial number of bacteria  
 $t$  = time (in hours)

In approximately how many hours will 4 bacteria first increase to 2,500 bacteria? Round your answer to the *nearest hour*.

215. Since January 1980, the population of the city of Brownville has grown according to the mathematical model  $y = 720,500(1.022)^x$ , where  $x$  is the number of years since January 1980.

Explain what the numbers 720,500 and 1.022 represent in this model.

If this trend continues, use this model to predict the year during which the population of Brownville will reach 1,548,800. [The use of the grid is optional.]

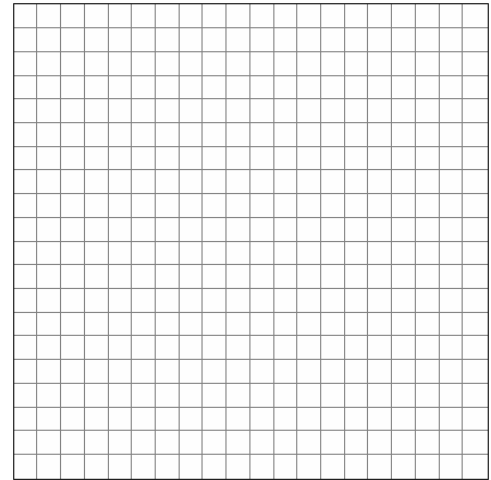

216. After an oven is turned on, its temperature,  $T$ , is represented by the equation  $T = 400 - 350(3.2)^{-0.1m}$  where  $m$  represents the number of minutes after the oven is turned on and  $T$  represents the temperature of the oven, in degrees Fahrenheit. How many minutes does it take for the oven's temperature to reach  $300^\circ\text{F}$ ? Round your answer to the *nearest minute*. [The use of the grid is optional.]

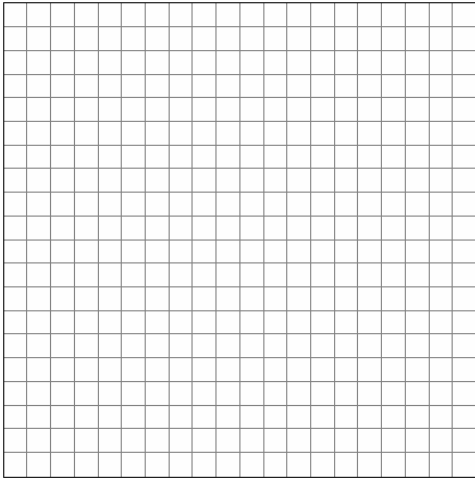

217. An amount of  $P$  dollars is deposited in an account paying an annual interest rate  $r$  (as a decimal) compounded  $n$  times per year. After  $t$  years, the amount of money in the account, in dollars, is given by the equation

$$A = P\left(1 + \frac{r}{n}\right)^{nt}$$

Rachel deposited \$1,000 at 2.8% annual interest, compounded monthly. In how many years, to the *nearest tenth of a year*, will she have \$2,500 in the account? [The use of the grid is optional.]

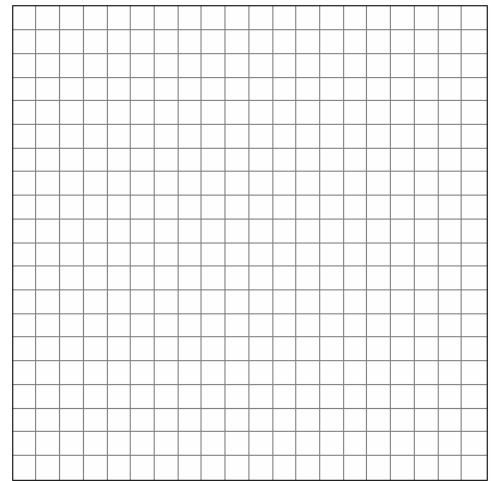

218. The equation for radioactive decay is  $p = (0.5)^{\frac{t}{H}}$ , where  $p$  is the part of a substance with half-life  $H$  remaining radioactive after a period of time,  $t$ . A given substance has a half-life of 6,000 years. After  $t$  years, one-fifth of the original sample remains radioactive. Find  $t$ , to the *nearest thousand years*.

219. An archaeologist can determine the approximate age of certain ancient specimens by measuring the amount of carbon-14, a radioactive substance, contained in the specimen. The formula used to determine the age of a specimen is  $A = A_0 2^{\frac{-t}{5760}}$ , where  $A$  is the amount of carbon-14 that a specimen contains,  $A_0$  is the original amount of carbon-14,  $t$  is time, in years, and 5760 is the half-life of carbon-14.  
A specimen that originally contained 120 milligrams of carbon-14 now contains 100 milligrams of this substance. What is the age of the specimen, to the *nearest hundred years*?

220. Depreciation (the decline in cash value) on a car can be determined by the formula  $V = C(1 - r)^t$ , where  $V$  is the value of the car after  $t$  years,  $C$  is the original cost, and  $r$  is the rate of depreciation. If a car's cost, when new, is \$15,000, the rate of depreciation is 30%, and the value of the car now is \$3,000, how old is the car to the *nearest tenth of a year*?

221. The amount  $A$ , in milligrams, of a 10-milligram dose of a drug remaining in the body after  $t$  hours is given by the formula  $A = 10(0.8)^t$ . Find, to the *nearest tenth of an hour*, how long it takes for half of the drug dose to be left in the body.

222. The current population of Little Pond, New York, is 20,000. The population is *decreasing*, as represented by the formula  $P = A(1.3)^{-0.234t}$ , where  $P$  = final population,  $t$  = time, in years, and  $A$  = initial population. What will the population be 3 years from now? Round your answer to the *nearest hundred people*.  
To the *nearest tenth of a year*, how many years will it take for the population to reach half the present population? [The use of the grid is optional.]

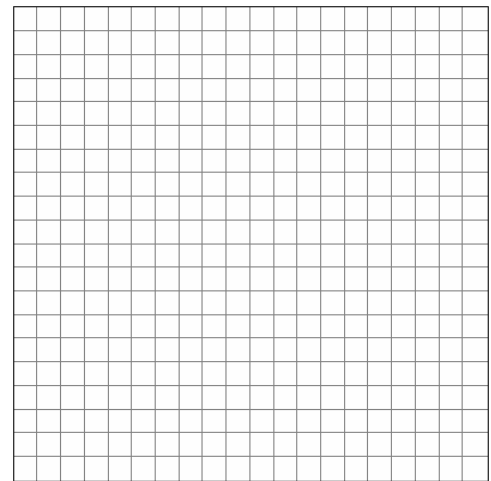

## CHAPTER 7-6

223. Sean invests \$10,000 at an annual rate of 5% compounded continuously, according to the formula  $A = Pe^{rt}$ , where  $A$  is the amount,  $P$  is the principal,  $e = 2.718$ ,  $r$  is the rate of interest, and  $t$  is time, in years.  
Determine, to the *nearest dollar*, the amount of money he will have after 2 years.  
Determine how many years, to the *nearest year*, it will take for his initial investment to double.

## CHAPTER 8-1

### INVERSE VARIATION

224. Explain how a person can determine if a set of data represents inverse variation and give an example using a table of values.
225. For a rectangular garden with a fixed area, the length of the garden varies inversely with the width. Which equation represents this situation for an area of 36 square units?
- [A]  $y = \frac{36}{x}$                       [B]  $x - y = 36$   
[C]  $x + y = 36$                       [D]  $y = 36x$
226. If  $R$  varies inversely as  $S$ , when  $S$  is doubled,  $R$  is multiplied by
- [A]  $\frac{1}{4}$                       [B]  $\frac{1}{2}$                       [C] 4                      [D] 2
227. In a given rectangle, the length varies inversely as the width. If the length is doubled, the width will
- [A] increase by 2                      [B] be multiplied by 2  
[C] be divided by 2                      [D] remain the same
228. The speed of a laundry truck varies inversely with the time it takes to reach its destination. If the truck takes 3 hours to reach its destination traveling at a constant speed of 50 miles per hour, how long will it take to reach the same location when it travels at a constant speed of 60 miles per hour?
- [A] 2 hours                      [B]  $2\frac{2}{3}$  hours  
[C]  $2\frac{1}{3}$  hours                      [D]  $2\frac{1}{2}$  hours
229. The time it takes to travel to a location varies inversely to the speed traveled. It takes 4 hours driving at an average speed of 55 miles per hour to reach a location. To the *nearest tenth of an hour*, how long will it take to reach the same location driving at an average speed of 50 miles per hour?
230. When air is pumped into an automobile tire, the pressure is inversely proportional to the volume. If the pressure is 35 pounds when the volume is 120 cubic inches, what is the pressure, in pounds, when the volume is 140 cubic inches?
231. Boyle's Law states that the pressure of compressed gas is inversely proportional to its volume. The pressure of a certain sample of a gas is 16 kilopascals when its volume is 1,800 liters. What is the pressure, in kilopascals, when its volume is 900 liters?
232. According to Boyle's Law, the pressure,  $p$ , of a compressed gas is inversely proportional to the volume,  $v$ . If a pressure of 20 pounds per square inch exists when the volume of the gas is 500 cubic inches, what is the pressure when the gas is compressed to 400 cubic inches?
- [A] 50 lb / in<sup>2</sup>                      [B] 25 lb / in<sup>2</sup>  
[C] 16 lb / in<sup>2</sup>                      [D] 40 lb / in<sup>2</sup>
233. Camisha is paying a band \$330 to play at her graduation party. The amount each member earns,  $d$ , varies inversely as the number of members who play,  $n$ . The graph of the equation that represents the relationship between  $d$  and  $n$  is an example of
- [A] an ellipse                      [B] a hyperbola  
[C] a line                      [D] a parabola

234. The price per person to rent a limousine for a prom varies inversely as the number of passengers. If five people rent the limousine, the cost is \$70 each. How many people are renting the limousine when the cost *per couple* is \$87.50?
235. To balance a seesaw, the distance, in feet, a person is from the fulcrum is inversely proportional to the person's weight, in pounds. Bill, who weighs 150 pounds, is sitting 4 feet away from the fulcrum. If Dan weighs 120 pounds, how far from the fulcrum should he sit to balance the seesaw?
- [A] 3.5 ft [B] 5 ft [C] 3 ft [D] 4.5 ft
236. A pulley that has a diameter of 8 inches is belted to a pulley that has a diameter of 12 inches. The 8-inch-diameter pulley is running at 1,548 revolutions per minute. If the speeds of the pulleys vary inversely to their diameters, how many revolutions per minute does the larger pulley make?

## CHAPTER 8-2

### RATIONAL FUNCTIONS

237. Which function is symmetrical with respect to the origin?
- [A]  $y = \sqrt{x+5}$  [B]  $y = |5-x|$   
[C]  $y = -\frac{5}{x}$  [D]  $y = 5^x$
238. Which equation represents a hyperbola?
- [A]  $y = 16 - x^2$  [B]  $y = \frac{16}{x}$   
[C]  $y^2 = 16 - x^2$  [D]  $y = 16x^2$

239. The accompanying graph shows the relationship between a person's weight and the distance that the person must sit from the center of a seesaw to make it balanced.

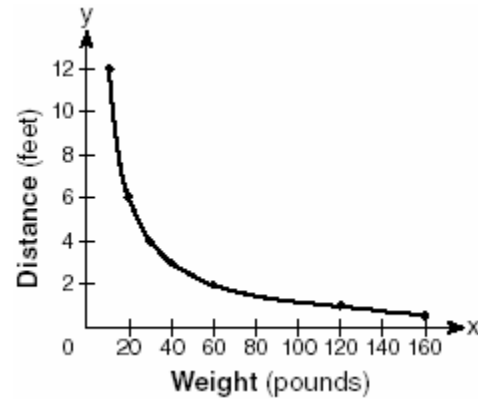

Which equation best represents this graph?

- [A]  $y = 12x^2$  [B]  $y = -120x$   
[C]  $y = 2 \log x$  [D]  $y = \frac{120}{x}$

240. Which graph shows that soil permeability varies inversely to runoff?

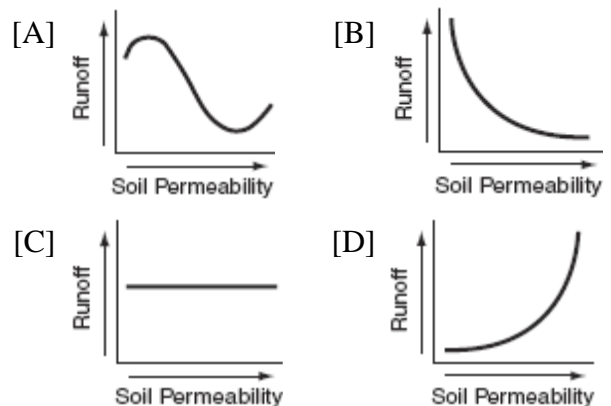

241. Which graph represents an inverse variation between stream velocity and the distance from the center of the stream?

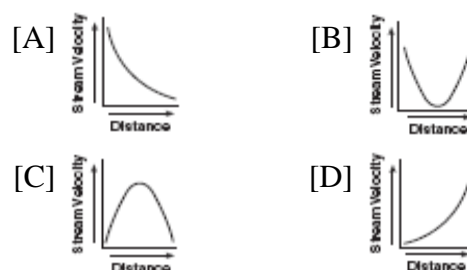



## MATH TOOLBOX P. 375

### RATIONALIZING DENOMINATORS

242. Which expression is equivalent to  $\frac{4}{3+\sqrt{2}}$ ?

[A]  $\frac{12-4\sqrt{2}}{7}$  [B]  $\frac{12+4\sqrt{2}}{11}$

[C]  $\frac{12-4\sqrt{2}}{11}$  [D]  $\frac{12+4\sqrt{2}}{7}$

243. The expression  $\frac{12}{3+\sqrt{3}}$  is equivalent to

[A]  $6-2\sqrt{3}$  [B]  $4-2\sqrt{3}$

[C]  $2+\sqrt{3}$  [D]  $12-\sqrt{3}$

244. The expression  $\frac{7}{2-\sqrt{3}}$  is equivalent to

[A]  $14-7\sqrt{3}$  [B]  $\frac{14+\sqrt{3}}{7}$

[C]  $14+7\sqrt{3}$  [D]  $\frac{2+\sqrt{3}}{7}$

245. The expression  $\frac{7}{3-\sqrt{2}}$  is equivalent to

[A]  $\frac{3+\sqrt{2}}{7}$  [B]  $3+\sqrt{2}$

[C]  $\frac{21+\sqrt{2}}{7}$  [D]  $3-\sqrt{2}$

246. The expression  $\frac{1}{5-\sqrt{13}}$  is equivalent to

[A]  $\frac{5+\sqrt{13}}{-8}$  [B]  $\frac{5+\sqrt{13}}{12}$

[C]  $\frac{5+\sqrt{13}}{-12}$  [D]  $\frac{5+\sqrt{13}}{8}$

247. The expression  $\frac{4}{5-\sqrt{13}}$  is equivalent to

[A]  $\frac{2(5-\sqrt{13})}{19}$  [B]  $\frac{2(5+\sqrt{13})}{19}$

[C]  $\frac{5+\sqrt{13}}{3}$  [D]  $\frac{5-\sqrt{13}}{3}$

248. The expression  $\frac{11}{\sqrt{3}-5}$  is equivalent to

[A]  $\frac{-\sqrt{3}+5}{2}$  [B]  $\frac{\sqrt{3}+5}{2}$

[C]  $\frac{\sqrt{3}-5}{2}$  [D]  $\frac{-\sqrt{3}-5}{2}$

249. The expression  $\frac{5}{\sqrt{5}-1}$  is equivalent to

[A]  $\frac{5}{4}$  [B]  $\frac{5\sqrt{5}-5}{4}$

[C]  $\frac{5\sqrt{5}-5}{6}$  [D]  $\frac{5\sqrt{5}+5}{4}$

250. The fraction  $\frac{3}{\sqrt{6}-1}$  is equivalent to

[A]  $3\sqrt{6}+3$  [B]  $3\sqrt{6}-3$

[C]  $\frac{3\sqrt{6}-3}{5}$  [D]  $\frac{3\sqrt{6}+3}{5}$

251. Which expression is equal to  $\frac{2+\sqrt{3}}{2-\sqrt{3}}$ ?

[A]  $\frac{1-4\sqrt{3}}{7}$  [B]  $\frac{7+4\sqrt{3}}{7}$

[C]  $7+4\sqrt{3}$  [D]  $1-4\sqrt{3}$

252. Which expression represents the sum of

$$\frac{1}{\sqrt{3}} + \frac{1}{\sqrt{2}}?$$

[A]  $\frac{\sqrt{3} + \sqrt{2}}{3}$

[B]  $\frac{\sqrt{3} + \sqrt{2}}{2}$

[C]  $\frac{2}{\sqrt{5}}$

[D]  $\frac{2\sqrt{3} + 3\sqrt{2}}{6}$

257. Express the following rational expression in simplest form:

$$\frac{9 - x^2}{10x^2 - 28x - 6}$$

258. For all values of  $x$  for which the expression is defined,  $\frac{2x + x^2}{x^2 + 5x + 6}$  is equivalent to

[A]  $\frac{1}{x+2}$

[B]  $\frac{x}{x+2}$

[C]  $\frac{x}{x+3}$

[D]  $\frac{1}{x+3}$

## CHAPTER 8-4

### RATIONAL EXPRESSIONS

253. Which expression is in simplest form?

[A]  $\frac{9}{x^2 + 9}$

[B]  $\frac{x}{x^2}$

[C]  $\frac{x^2 - 6x + 9}{x^2 - x - 6}$

[D]  $\frac{x^2 - 4}{x + 2}$

254. Written in simplest form, the expression

$$\frac{x^2y^2 - 9}{3 - xy}$$
 is equivalent to

[A]  $-(3 + xy)$

[B]  $\frac{1}{3 + xy}$

[C]  $-1$

[D]  $3 + xy$

255. Written in simplest form, the expression

$$\frac{x^2 - 9x}{45x - 5x^2}$$
 is equivalent to

[A] 5    [B]  $-\frac{1}{5}$     [C]  $-5$     [D]  $\frac{1}{5}$

256. The expression  $\frac{3y^2 - 12y}{4y^2 - y^3}$  is equivalent to

[A]  $-\frac{9}{4}$     [B]  $-\frac{3}{y}$     [C]  $\frac{3}{4} - \frac{12}{y^2}$     [D]  $\frac{3}{y}$

### COMPLEX FRACTIONS

259. The expression  $\frac{\frac{a}{b} - \frac{b}{a}}{\frac{1}{a} + \frac{1}{b}}$  is equivalent to

[A]  $\frac{a-b}{ab}$

[B]  $a + b$

[C]  $ab$

[D]  $a - b$

260. The fraction  $\frac{\frac{x}{y} + x}{\frac{1}{y} + 1}$  is equivalent to

[A]  $x$     [B]  $\frac{x^2y}{1+y}$     [C]  $2x$     [D]  $\frac{2xy}{1+y}$

261. In simplest form,  $\frac{\frac{1}{x^2} - \frac{1}{y^2}}{\frac{1}{y} + \frac{1}{x}}$  is equal to

[A]  $\frac{y-x}{xy}$

[B]  $x - y$

[C]  $\frac{x-y}{xy}$

[D]  $y - x$

262. The expression  $\frac{\frac{1}{3} + \frac{1}{3x}}{\frac{1}{x} + \frac{1}{3}}$  is equivalent to

- [A] 2    [B]  $\frac{x+1}{x+3}$     [C]  $\frac{3x+3}{x+3}$     [D]  $\frac{1}{3}$

263. The expression  $\frac{\frac{1}{3} - \frac{1}{3x}}{\frac{3}{x} - 1}$  is equivalent to

- [A]  $-\frac{1}{3}$     [B] -3    [C] 3    [D]  $\frac{1}{3}$

264. Express in simplest form:  $\frac{\frac{x}{4} - \frac{4}{x}}{1 - \frac{4}{x}}$

265. The expression  $\frac{\frac{1}{x} + \frac{1}{y}}{\frac{1}{x^2} - \frac{1}{y^2}}$  is equivalent to

- [A]  $\frac{y-x}{xy}$     [B]  $y-x$   
[C]  $\frac{xy}{y-x}$     [D]  $\frac{xy}{x-y}$

266. Which expression is equivalent to the

complex fraction  $\frac{\frac{x}{x+2}}{1 - \frac{x}{x+2}}$ ?

- [A]  $\frac{2x}{x+2}$     [B]  $\frac{2x}{x^2+4}$     [C]  $\frac{2}{x}$     [D]  $\frac{x}{2}$

267. Express in simplest form:  $\frac{\frac{1}{r} - \frac{1}{s}}{\frac{r^2}{s^2} - 1}$

268. When simplified, the complex fraction

$\frac{1 + \frac{1}{x}}{\frac{1}{1-x}}$ ,  $x \neq 0$ , is equivalent to

- [A] 1    [B] -1    [C]  $\frac{1}{x-1}$     [D]  $\frac{1}{1-x}$

269. Simplify completely:  $\frac{\frac{1-m}{m}}{m - \frac{1}{m}}$

270. Simplify for all values of  $a$  for which the

expression is defined:  $\frac{1 - \frac{2}{a}}{\frac{4}{a^2} - 1}$

271. In a science experiment, when resistor  $A$  and resistor  $B$  are connected in a parallel circuit, the total resistance is  $\frac{1}{\frac{1}{A} + \frac{1}{B}}$ . This complex

fraction is equivalent to

- [A]  $A + B$     [B]  $\frac{AB}{A+B}$     [C] 1    [D]  $AB$

### MULTIPLICATION AND DIVISION OF RATIONALS

272. A rectangular prism has a length of

$\frac{2x^2 + 2x - 24}{4x^2 + x}$ , a width of  $\frac{x^2 + x - 6}{x + 4}$ , and a

height of  $\frac{8x^2 + 2x}{x^2 - 9}$ . For all values of  $x$  for

which it is defined, express, in terms of  $x$ , the volume of the prism in simplest form.

273. If the length of a rectangular garden is represented by  $\frac{x^2 + 2x}{x^2 + 2x - 15}$  and its width is represented by  $\frac{2x - 6}{2x + 4}$ , which expression represents the area of the garden?
- [A]  $x$                       [B]  $x + 5$
- [C]  $\frac{x}{x + 5}$                       [D]  $\frac{x^2 + 2x}{2(x + 5)}$

274. If  $f(x) = \frac{3x^2 - 27}{18x + 30}$  and  $g(x) = \frac{x^2 - 7x + 12}{3x^2 - 7x - 20}$ , find  $f(x) \div g(x)$  for all values of  $x$  for which the expression is defined and express your answer in simplest form.

275. Express in simplest form:

$$\frac{4x + 8}{x + 1} \cdot \frac{2 - x}{3x - 15} \div \frac{x^2 - 4}{2x^2 - 8x - 10}$$

276. Perform the indicated operations and simplify completely:

$$\frac{x^2 - 9}{x^2 - 5x} \cdot \frac{5x - x^2}{x^2 - x - 12} \div \frac{x - 4}{x^2 - 8x + 16}$$

## CHAPTER 8-5

### ADDITION AND SUBTRACTION OF RATIONALS

277. Express in simplest form:  $\frac{1}{x} + \frac{1}{x + 3}$
278. What is the sum of  $\frac{3}{x - 3}$  and  $\frac{x}{3 - x}$ ?
- [A] 1      [B] 0      [C] -1      [D]  $\frac{x + 3}{x - 3}$

279. What is the sum of  $(y - 5) + \frac{3}{y + 2}$ ?

- [A]  $y - 5$                       [B]  $\frac{y^2 - 3y - 7}{y + 2}$
- [C]  $\frac{y - 2}{y + 2}$                       [D]  $\frac{y^2 - 7}{y + 2}$

## CHAPTER 8-6

### SOLVING RATIONALS

280. Solve for all values of  $x$ :  $\frac{9}{x} + \frac{9}{x - 2} = 12$
281. Solve for  $x$  and express your answer in simplest radical form:
- $$\frac{4}{x} - \frac{3}{x + 1} = 7$$
282. What is the solution set of the equation  $\frac{x}{x - 4} - \frac{1}{x + 3} = \frac{28}{x^2 - x - 12}$ ?
- [A] {4, -6}      [B] { }      [C] {-6}      [D] {4}
283. A rectangle is said to have a golden ratio when  $\frac{w}{h} = \frac{h}{w - h}$ , where  $w$  represents width and  $h$  represents height. When  $w = 3$ , between which two consecutive integers will  $h$  lie?
284. Working by herself, Mary requires 16 minutes more than Antoine to solve a mathematics problem. Working together, Mary and Antoine can solve the problem in 6 minutes. If this situation is represented by the equation  $\frac{6}{t} + \frac{6}{t + 16} = 1$ , where  $t$  represents the number of minutes Antoine works alone to solve the problem, how many minutes will it take Antoine to solve the problem if he works by himself?

285. Electrical circuits can be connected in series, one after another, or in parallel circuits that branch off a main line. If circuits are hooked up in parallel, the reciprocal of the total resistance in the series is found by adding the reciprocals of each resistance, as shown in the accompanying diagram.

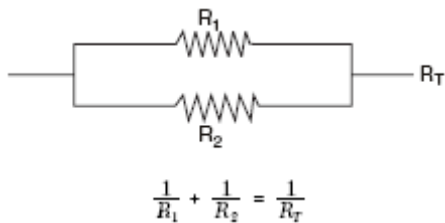

If  $R_1 = x$ ,  $R_2 = x + 3$ , and the total resistance,  $R_T$ , is 2.25 ohms, find the positive value of  $R_1$  to the nearest tenth of an ohm.

289. In the accompanying diagram, point  $P(0.6, -0.8)$  is on unit circle  $O$ . What is the value of  $\theta$ , to the nearest degree?

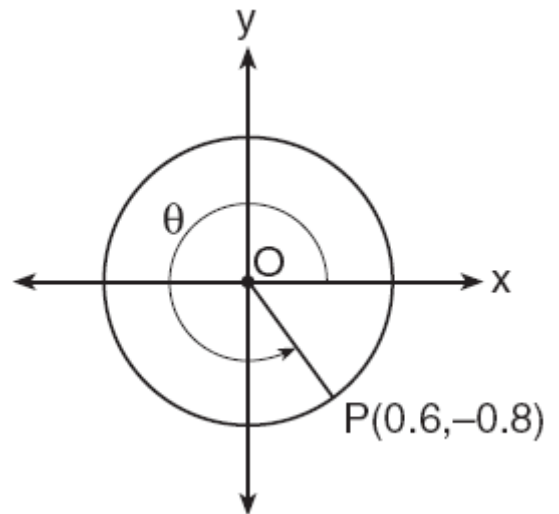

290. In the accompanying diagram of a unit circle, the ordered pair  $(-\frac{\sqrt{3}}{2}, -\frac{1}{2})$  represents the point where the terminal side of  $\theta$  intersects the unit circle.

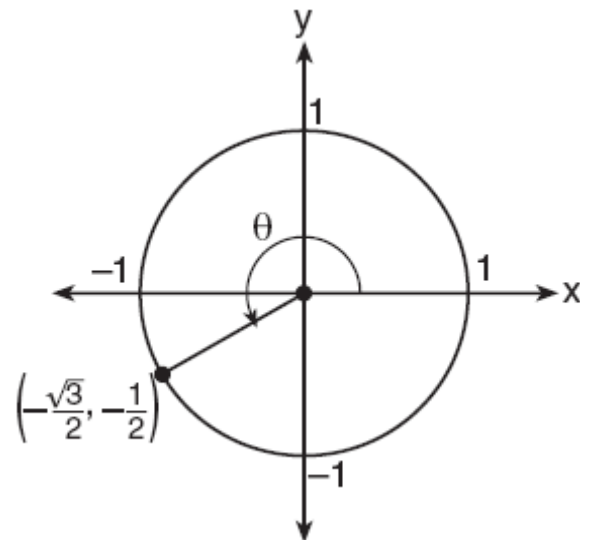

What is  $m\angle\theta$ ?

## CHAPTER 9-2

### UNIT CIRCLE

286. Which angle is coterminal with an angle of  $125^\circ$ ?
- [A]  $235^\circ$                       [B]  $-235^\circ$   
[C]  $-125^\circ$                       [D]  $425^\circ$
287. Expressed as a function of a positive acute angle,  $\sin(-230^\circ)$  is equal to
- [A]  $-\cos 50^\circ$                       [B]  $-\sin 50^\circ$   
[C]  $\sin 50^\circ$                       [D]  $\cos 50^\circ$
288. If  $\theta$  is an angle in standard position and its terminal side passes through the point  $(\frac{1}{2}, \frac{\sqrt{3}}{2})$  on a unit circle, a possible value of  $\theta$  is
- [A]  $120^\circ$     [B]  $30^\circ$     [C]  $150^\circ$     [D]  $60^\circ$

- [A] 233    [B] 240    [C] 210    [D] 225

291. In the unit circle shown in the accompanying diagram, what are the coordinates of  $(x, y)$ ?

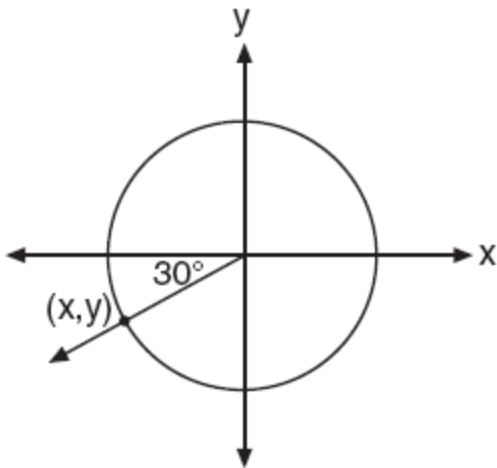

- [A]  $(-30, -210)$       [B]  $(-\frac{\sqrt{2}}{2}, -\frac{\sqrt{2}}{2})$   
 [C]  $(-0.5, -\frac{\sqrt{3}}{2})$       [D]  $(-\frac{\sqrt{3}}{2}, -0.5)$

292. If the sine of an angle is  $\frac{3}{5}$  and the angle is *not* in Quadrant I, what is the value of the cosine of the angle?

293. In the accompanying diagram,  $\overline{PR}$  is tangent to circle  $O$  at  $R$ ,  $\overline{QS} \perp \overline{OR}$ , and  $\overline{PR} \perp \overline{OR}$ .

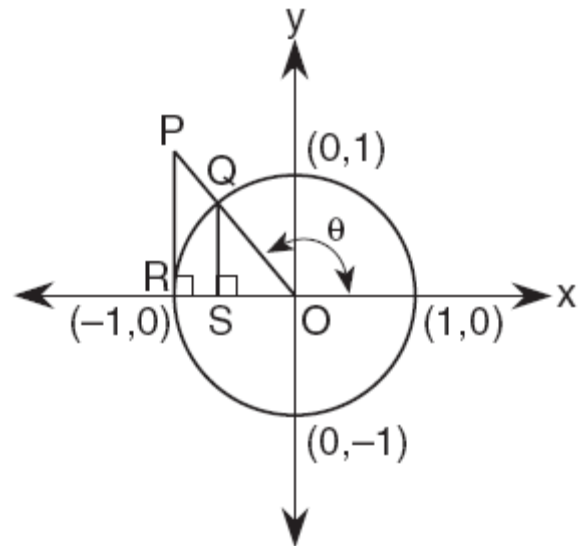

Which measure represents  $\sin \theta$ ?

- [A] QS    [B] PR    [C] SO    [D] RO

294. If  $x$  is a positive acute angle and  $\cos x = \frac{\sqrt{3}}{4}$ , what is the exact value of  $\sin x$ ?

- [A]  $\frac{3}{5}$     [B]  $\frac{\sqrt{13}}{4}$     [C]  $\frac{4}{5}$     [D]  $\frac{\sqrt{3}}{5}$

295. The accompanying diagram shows unit circle  $O$ , with radius  $OB = 1$ .

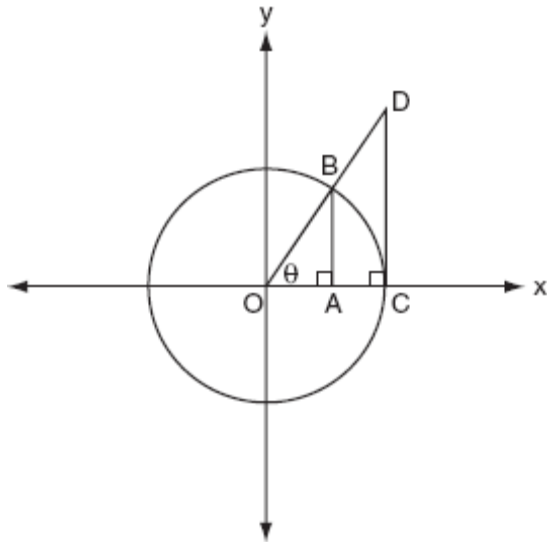

Which line segment has a length equivalent to  $\cos \theta$ ?

- [A]  $\overline{OC}$  [B]  $\overline{AB}$  [C]  $\overline{OA}$  [D]  $\overline{CD}$
296. Two straight roads intersect at an angle whose measure is  $125^\circ$ . Which expression is equivalent to the cosine of this angle?
- [A]  $\cos 35^\circ$  [B]  $-\cos 55^\circ$   
[C]  $\cos 55^\circ$  [D]  $-\cos 35^\circ$
297. If  $\theta$  is an angle in standard position and  $P(-3,4)$  is a point on the terminal side of  $\theta$ , what is the value of  $\sin \theta$ ?
- [A]  $-\frac{4}{5}$  [B]  $\frac{4}{5}$  [C]  $\frac{3}{5}$  [D]  $-\frac{3}{5}$
298. If  $\sin \theta > 0$  and  $\sec \theta < 0$ , in which quadrant does the terminal side of angle  $\theta$  lie?
- [A] IV [B] III [C] II [D] I
299. If the tangent of an angle is negative and its secant is positive, in which quadrant does the angle terminate?
- [A] I [B] IV [C] II [D] III

300. If  $\sin \theta$  is negative and  $\cos \theta$  is negative, in which quadrant does the terminal side of  $\theta$  lie?
- [A] I [B] III [C] IV [D] II
301. If  $\tan \theta = 2.7$  and  $\csc \theta < 0$ , in which quadrant does  $\theta$  lie?
- [A] IV [B] II [C] I [D] III
302. If  $\theta$  is an obtuse angle and  $\sin \theta = b$ , then it can be concluded that
- [A]  $\cos \theta > b$  [B]  $\cos 2\theta > b$   
[C]  $\tan \theta > b$  [D]  $\sin 2\theta < b$
303. Is  $\frac{1}{2} \sin 2x$  the same expression as  $\sin x$ ? Justify your answer.

## CHAPTER 9-3

### RADIAN MEASURE

304. What is the number of degrees in an angle whose radian measure is  $\frac{7\pi}{12}$ ?
305. Through how many radians does the minute hand of a clock turn in 24 minutes?
- [A]  $0.6\pi$  [B]  $0.2\pi$   
[C]  $0.4\pi$  [D]  $0.8\pi$
306. What is the radian measure of the angle formed by the hands of a clock at 2:00 p.m.?
- [A]  $\frac{\pi}{4}$  [B]  $\frac{\pi}{6}$  [C]  $\frac{\pi}{2}$  [D]  $\frac{\pi}{3}$
307. An art student wants to make a string collage by connecting six equally spaced points on the circumference of a circle to its center with string. What would be the radian measure of the angle between two adjacent pieces of string, in simplest form?

308. A wedge-shaped piece is cut from a circular pizza. The radius of the pizza is 6 inches. The rounded edge of the crust of the piece measures 4.2 inches. To the *nearest tenth*, the angle of the pointed end of the piece of pizza, in radians, is
- [A] 1.4    [B] 0.7    [C] 7.0    [D] 25.2

309. A dog has a 20-foot leash attached to the corner where a garage and a fence meet, as shown in the accompanying diagram. When the dog pulls the leash tight and walks from the fence to the garage, the arc the leash makes is 55.8 feet.

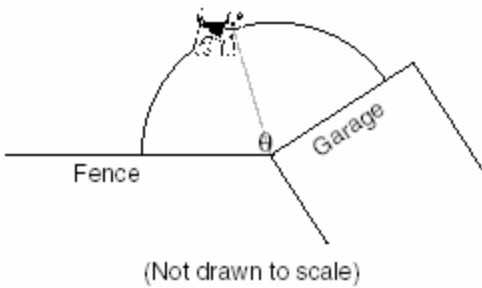

What is the measure of angle  $\theta$  between the garage and the fence, in radians?

- [A] 0.36    [B] 3.14    [C] 2.79    [D] 160

310. Kristine is riding in car 4 of the Ferris wheel represented in the accompanying diagram. The Ferris wheel is rotating in the direction indicated by the arrows. The eight cars are equally spaced around the circular wheel. Express, in radians, the measure of the *smallest* angle through which she will travel to reach the bottom of the Ferris wheel.

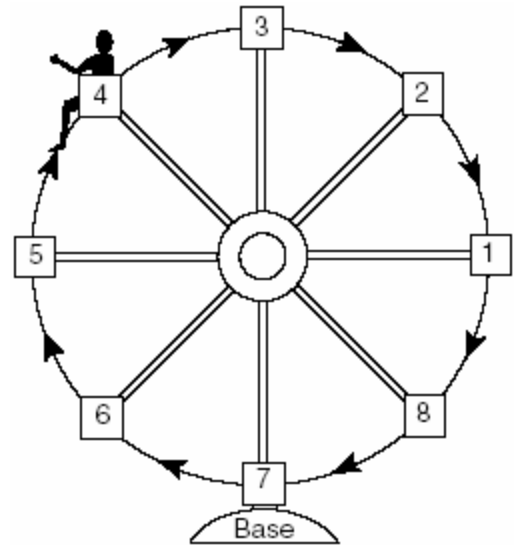

311. An arc of a circle that is 6 centimeters in length intercepts a central angle of 1.5 radians. Find the number of centimeters in the radius of the circle.
312. The pendulum of a clock swings through an angle of 2.5 radians as its tip travels through an arc of 50 centimeters. Find the length of the pendulum, in centimeters.

## CHAPTER 9-4

### TRIGONOMETRIC GRAPHS

313. What is the period of the function  $y = 5\sin 3x$ ?

- [A] 5    [B] 3    [C]  $\frac{2\pi}{5}$     [D]  $\frac{2\pi}{3}$



314. What is the period of the graph of the equation  $y = 2 \sin \frac{1}{3}x$ ?

- [A]  $\frac{3\pi}{2}$  [B]  $2\pi$  [C]  $\frac{2}{3}\pi$  [D]  $6\pi$

315. A sound wave is modeled by the curve  $y = 3 \sin 4x$ . What is the period of this curve?

- [A] 4 [B]  $\frac{\pi}{2}$  [C]  $\pi$  [D] 3

316. A certain radio wave travels in a path represented by the equation  $y = 5 \sin 2x$ . What is the period of this wave?

- [A]  $2\pi$  [B]  $\pi$  [C] 2 [D] 5

317. A modulated laser heats a diamond. Its variable temperature, in degrees Celsius, is given by  $f(t) = T \sin at$ . What is the period of the curve?

- [A]  $\frac{2\pi}{a}$  [B]  $\frac{1}{a}$  [C]  $|T|$  [D]  $\frac{2a\pi}{a}$

318. The brightness of the star MIRA over time is given by the equation  $y = 2 \sin \frac{\pi}{4}x + 6$ , where  $x$  represents time and  $y$  represents brightness. What is the period of this function, in radian measure?

319. What is the amplitude of the function shown in the accompanying graph?

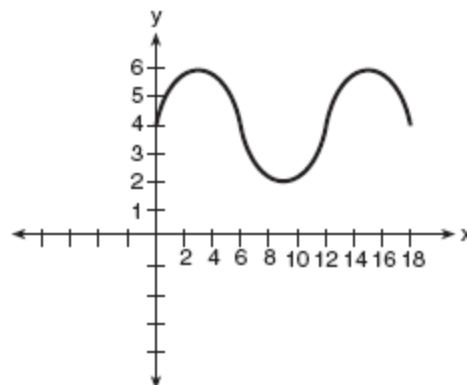

- [A] 2 [B] 1.5 [C] 12 [D] 6

320. What is the amplitude of the function  $y = \frac{2}{3} \sin 4x$ ?

- [A] 4 [B]  $3\pi$  [C]  $\frac{\pi}{2}$  [D]  $\frac{2}{3}$

321. A monitor displays the graph  $y = 3 \sin 5x$ . What will be the amplitude after a dilation of 2?

- [A] 6 [B] 5 [C] 7 [D] 10

322. The path traveled by a roller coaster is modeled by the equation  $y = 27 \sin 13x + 30$ . What is the maximum altitude of the roller coaster?

- [A] 27 [B] 57 [C] 13 [D] 30

323. In physics class, Eva noticed the pattern shown in the accompanying diagram on an oscilloscope.

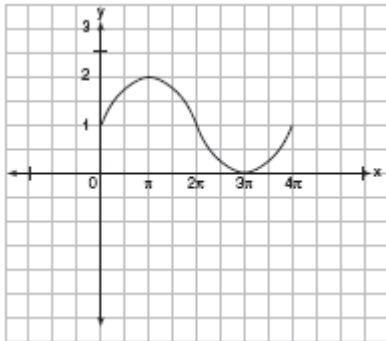

Which equation best represents the pattern shown on this oscilloscope?

- [A]  $y = 2 \sin(-\frac{1}{2}x) + 1$
- [B]  $y = \sin x + 1$       [C]  $y = \sin(\frac{1}{2}x) + 1$
- [D]  $y = 2 \sin x + 1$
324. A radio transmitter sends a radio wave from the top of a 50-foot tower. The wave is represented by the accompanying graph.

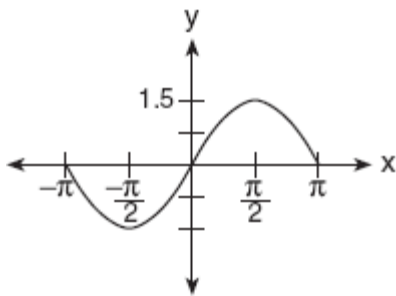

What is the equation of this radio wave?

- [A]  $y = \sin x$       [B]  $y = 2 \sin x$
- [C]  $y = 1.5 \sin x$       [D]  $y = \sin 1.5x$

325. A student attaches one end of a rope to a wall at a fixed point 3 feet above the ground, as shown in the accompanying diagram, and moves the other end of the rope up and down, producing a wave described by the equation  $y = a \sin bx + c$ . The range of the rope's height above the ground is between 1 and 5 feet. The period of the wave is  $4\pi$ . Write the equation that represents this wave.

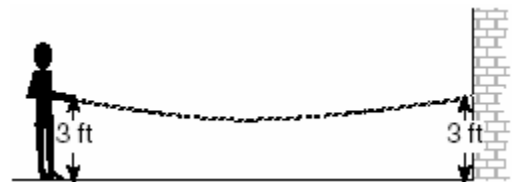

## CHAPTER 9-5

326. An object that weighs 2 pounds is suspended in a liquid. When the object is depressed 3 feet from its equilibrium point, it will oscillate according to the formula  $x = 3 \cos(8t)$ , where  $t$  is the number of seconds after the object is released. How many seconds are in the period of oscillation?

- [A] 3      [B]  $2\pi$       [C]  $\frac{\pi}{4}$       [D]  $\pi$

327. The shaded portion of the accompanying map indicates areas of night, and the unshaded portion indicates areas of daylight at a particular moment in time.

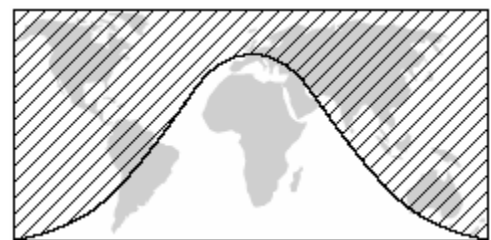

Which type of function best represents the curve that divides the area of night from the area of daylight?

- [A] cosine      [B] logarithmic
- [C] tangent      [D] quadratic

328. Which transformation could be used to make the graph of the equation  $y = \sin x$  coincide with the graph of the equation  $y = \cos x$ ?

- [A] dilation                      [B] rotation  
[C] translation                [D] point reflection

329. The graphs below show the average annual precipitation received at different latitudes on Earth. Which graph is a translated cosine curve?

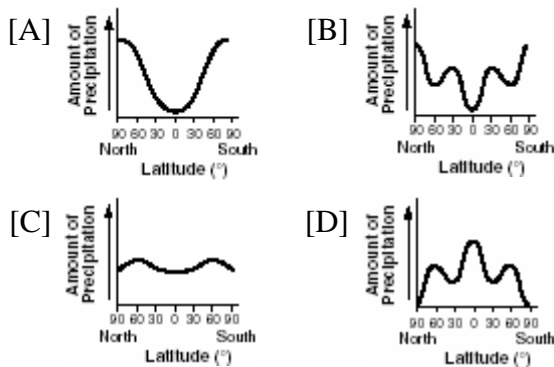

330. Which type of symmetry does the equation  $y = \cos x$  have?

- [A] line symmetry with respect to the  $x$ -axis  
[B] point symmetry with respect to the origin  
[C] point symmetry with respect to  $(\frac{\pi}{2}, 0)$   
[D] line symmetry with respect to  $y = x$

331. Which equation is represented by the accompanying graph?

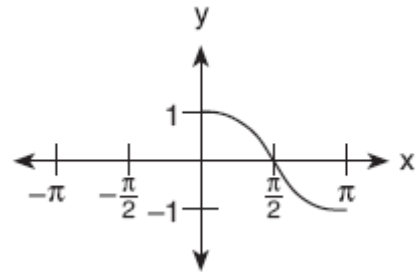

- [A]  $y = \cos 2x$                 [B]  $y = \cos \frac{1}{2}x$   
[C]  $y = \frac{1}{2} \cos x$             [D]  $y = \cos x$

332. The accompanying diagram shows a section of a sound wave as displayed on an oscilloscope.

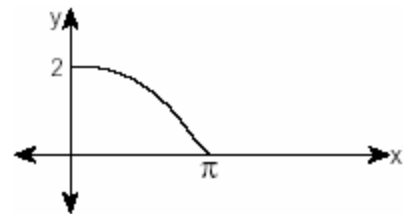

Which equation could represent this graph?

- [A]  $y = \frac{1}{2} \cos 2x$             [B]  $y = \frac{1}{2} \sin \frac{\pi}{2}x$   
[C]  $y = 2 \cos \frac{x}{2}$             [D]  $y = 2 \sin \frac{x}{2}$

333. The times of average monthly sunrise, as shown in the accompanying diagram, over the course of a 12-month interval can be modeled by the equation  $y = A \cos(Bx) + D$ . Determine the values of  $A$ ,  $B$ , and  $D$ , and explain how you arrived at your values.

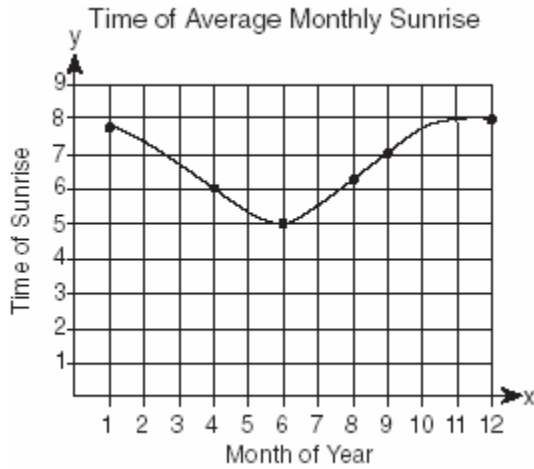

**TRIGONOMETRIC INEQUALITIES**

334. A building's temperature,  $T$ , varies with time of day,  $t$ , during the course of 1 day, as follows:

$$T = 8 \cos t + 78$$

The air-conditioning operates when  $T \geq 80^\circ F$ . Graph this function for  $6 \leq t < 17$  and determine, to the *nearest tenth of an hour*, the amount of time in 1 day that the air-conditioning is on in the building.

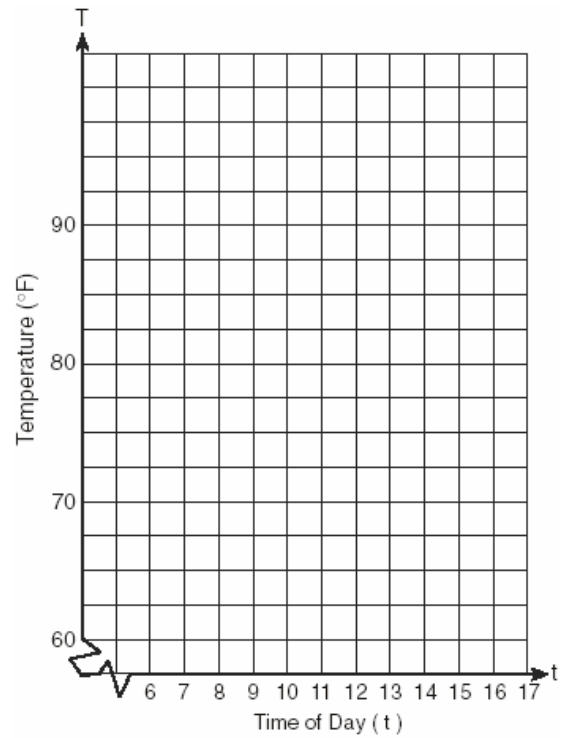

335. The tide at a boat dock can be modeled by the equation  $y = -2\cos\left(\frac{\pi}{6}t\right) + 8$ , where  $t$  is the number of hours past noon and  $y$  is the height of the tide, in feet. For how many hours between  $t = 0$  and  $t = 12$  is the tide at least 7 feet? [The use of the grid is optional.]

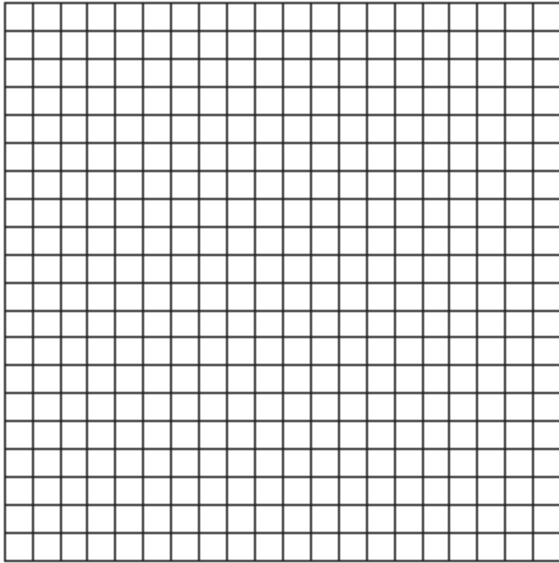

336. On the accompanying set of axes, graph the equations  $y = 4\cos x$  and  $y = 2$  in the domain  $-\pi \leq x \leq \pi$ . Express, in terms of  $\pi$ , the interval for which  $4\cos x \geq 2$ .

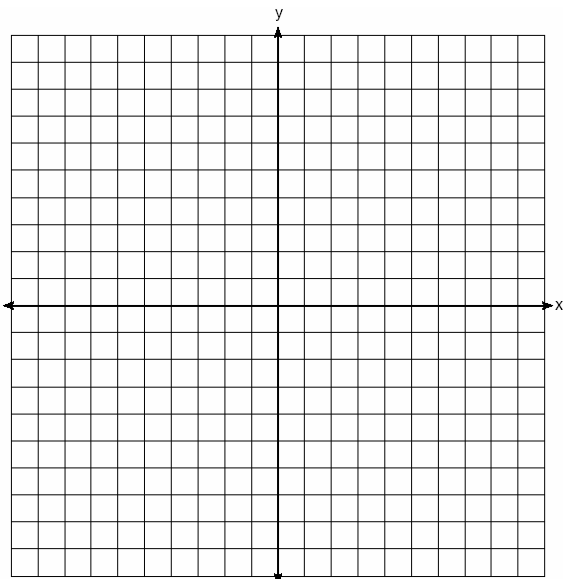

**SYSTEMS**

337. A pair of figure skaters graphed part of their routine on a grid. The male skater's path is represented by the equation  $m(x) = 3\sin\frac{1}{2}x$ , and the female skater's path is represented by the equation  $f(x) = -2\cos x$ . On the accompanying grid, sketch both paths and state how many times the paths of the skaters intersect between  $x = 0$  and  $x = 4\pi$ .

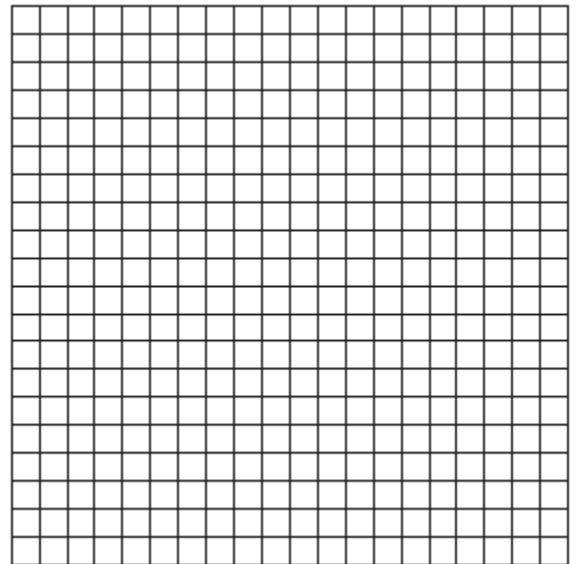

338. On a monitor, the graphs of two impulses are recorded on the same screen, where  $0^\circ \leq x < 360^\circ$ . The impulses are given by the following equations:  

$$y = 2\sin^2 x$$

$$y = 1 - \sin x$$
 Find all values of  $x$ , in degrees, for which the two impulses meet in the interval  $0^\circ \leq x < 360^\circ$ . [Only an algebraic solution will be accepted.]

## CHAPTER 9-7

### LAW OF COSINES

339. Two straight roads, Elm Street and Pine Street, intersect creating a  $40^\circ$  angle, as shown in the accompanying diagram. John's house ( $J$ ) is on Elm Street and is 3.2 miles from the point of intersection. Mary's house ( $M$ ) is on Pine Street and is 5.6 miles from the intersection. Find, to the *nearest tenth of a mile*, the direct distance between the two houses.

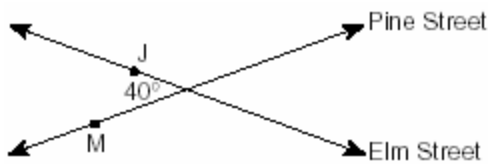

340. A ship at sea is 70 miles from one radio transmitter and 130 miles from another. The angle between the signals sent to the ship by the transmitters is  $117.4^\circ$ . Find the distance between the two transmitters, to the *nearest mile*.
341. The Vietnam Veterans Memorial in Washington, D.C., is made up of two walls, each 246.75 feet long, that meet at an angle of  $125.2^\circ$ . Find, to the *nearest foot*, the distance between the ends of the walls that do not meet.
342. To measure the distance through a mountain for a proposed tunnel, surveyors chose points  $A$  and  $B$  at each end of the proposed tunnel and a point  $C$  near the mountain. They determined that  $AC = 3,800$  meters,  $BC = 2,900$  meters, and  $m\angle ACB = 110$ . Draw a diagram to illustrate this situation and find the length of the tunnel, to the *nearest meter*.

343. A wooden frame is to be constructed in the form of an isosceles trapezoid, with diagonals acting as braces to strengthen the frame. The sides of the frame each measure 5.30 feet, and the longer base measures 12.70 feet. If the angles between the sides and the longer base each measure  $68.4^\circ$ , find the length of one brace to the *nearest tenth of a foot*.
344. Kieran is traveling from city  $A$  to city  $B$ . As the accompanying map indicates, Kieran could drive directly from  $A$  to  $B$  along County Route 21 at an average speed of 55 miles per hour or travel on the interstates, 45 miles along I-85 and 20 miles along I-64. The two interstates intersect at an angle of  $150^\circ$  at  $C$  and have a speed limit of 65 miles per hour. How much time will Kieran save by traveling along the interstates at an average speed of 65 miles per hour?

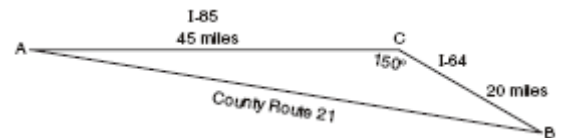

345. A surveyor is mapping a triangular plot of land. He measures two of the sides and the angle formed by these two sides and finds that the lengths are 400 yards and 200 yards and the included angle is  $50^\circ$ . What is the measure of the third side of the plot of land, to the *nearest yard*? What is the area of this plot of land, to the *nearest square yard*?
346. A triangular plot of land has sides that measure 5 meters, 7 meters, and 10 meters. What is the area of this plot of land, to the *nearest tenth of a square meter*?

347. A farmer has determined that a crop of strawberries yields a yearly profit of \$1.50 per square yard. If strawberries are planted on a triangular piece of land whose sides are 50 yards, 75 yards, and 100 yards, how much profit, to the *nearest hundred dollars*, would the farmer expect to make from this piece of land during the next harvest?

**LAW OF SINES**

348. The accompanying diagram shows the approximate linear distances traveled by a sailboat during a race. The sailboat started at point *S*, traveled to points *E* and *A*, respectively, and ended at point *S*.

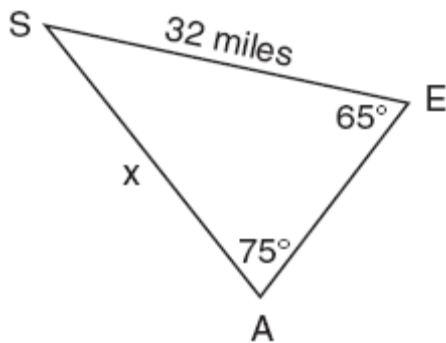

Based on the measures shown in the diagram, which equation can be used to find *x*, the distance from point *A* to point *S*?

- [A]  $\frac{\sin 65^\circ}{x} = \frac{\sin 75^\circ}{32}$   
 [B]  $\frac{x}{\sin 65^\circ} = \frac{\sin 75^\circ}{32}$   
 [C]  $\frac{65}{x} = \frac{32}{75}$       [D]  $\frac{x}{65} = \frac{32}{75}$

349. In  $\triangle ABC$ ,  $a = 19$ ,  $c = 10$ , and  $m\angle A = 111$ . Which statement can be used to find the value of  $\angle C$ ?

[A]  $\sin C = \frac{19 \sin 69^\circ}{10}$

[B]  $\sin C = \frac{10 \sin 21^\circ}{19}$

[C]  $\sin C = \frac{10}{19}$       [D]  $\sin C = \frac{10 \sin 69^\circ}{19}$

350. In  $\triangle ABC$ ,  $m\angle A = 53$ ,  $m\angle B = 14$ , and  $a = 10$ . Find  $b$  to the *nearest integer*.
351. In  $\triangle ABC$ ,  $m\angle A = 33$ ,  $a = 12$ , and  $b = 15$ . What is  $m\angle B$  to the *nearest degree*?
- [A] 41    [B] 43    [C] 48    [D] 44

352. A ski lift begins at ground level 0.75 mile from the base of a mountain whose face has a  $50^\circ$  angle of elevation, as shown in the accompanying diagram. The ski lift ascends in a straight line at an angle of  $20^\circ$ . Find the length of the ski lift from the beginning of the ski lift to the top of the mountain, to the *nearest hundredth of a mile*.

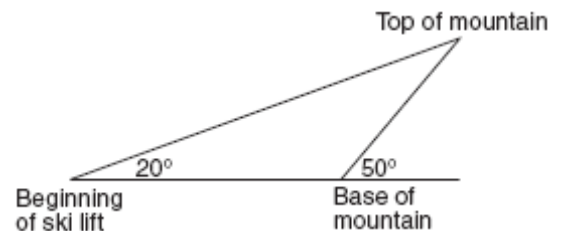

353. In the accompanying diagram of  $\triangle ABC$ ,  $m\angle A = 30$ ,  $m\angle C = 50$ , and  $AC = 13$ .

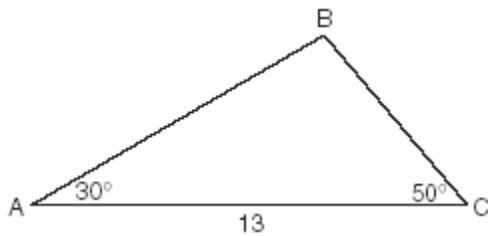

What is the length of side  $\overline{AB}$  to the nearest tenth?

- [A] 11.5 [B] 10.1 [C] 12.0 [D] 6.6

354. As shown in the accompanying diagram, two tracking stations,  $A$  and  $B$ , are on an east-west line 110 miles apart. A forest fire is located at  $F$ , on a bearing  $42^\circ$  northeast of station  $A$  and  $15^\circ$  northeast of station  $B$ . How far, to the nearest mile, is the fire from station  $A$ ?

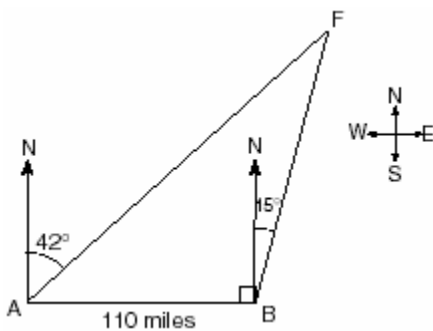

355. In the accompanying diagram of  $\triangle ABC$ ,  $m\angle A = 65$ ,  $m\angle B = 70$ , and the side opposite vertex  $B$  is 7. Find the length of the side opposite vertex  $A$ , and find the area of  $\triangle ABC$ .

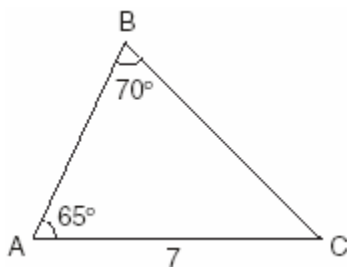

356. Carmen and Jamal are standing 5,280 feet apart on a straight, horizontal road. They observe a hot-air balloon between them directly above the road. The angle of elevation from Carmen is  $60^\circ$  and from Jamal is  $75^\circ$ . Draw a diagram to illustrate this situation and find the height of the balloon to the nearest foot.

357. In the accompanying diagram of a streetlight, the light is attached to a pole at  $R$  and supported by a brace,  $\overline{PQ}$ ,  $RQ = 10$  feet,  $RP = 6$  feet,  $\angle PRQ$  is an obtuse angle, and  $m\angle PQR = 30$ . Find the length of the brace,  $\overline{PQ}$ , to the nearest foot.

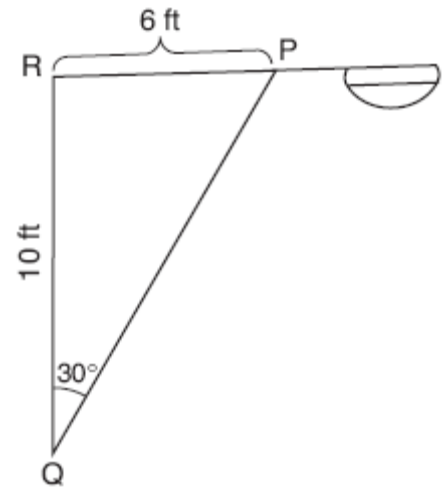

358. A ship at sea heads directly toward a cliff on the shoreline. The accompanying diagram shows the top of the cliff,  $D$ , sighted from two locations,  $A$  and  $B$ , separated by distance  $S$ . If  $m\angle DAC = 30$ ,  $m\angle DBC = 45$ , and  $S = 30$  feet, what is the height of the cliff, to the nearest foot?

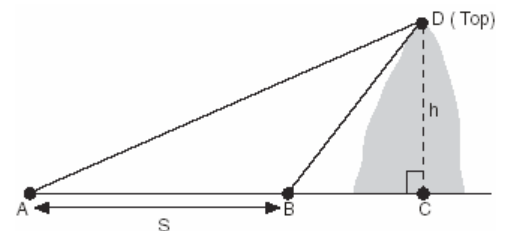



359. The accompanying diagram shows the plans for a cell-phone tower that is to be built near a busy highway. Find the height of the tower, to the *nearest foot*.

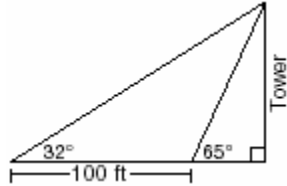

360. A ship captain at sea uses a sextant to sight an angle of elevation of  $37^\circ$  to the top of a lighthouse. After the ship travels 250 feet directly toward the lighthouse, another sighting is made, and the new angle of elevation is  $50^\circ$ . The ship's charts show that there are dangerous rocks 100 feet from the base of the lighthouse. Find, to the *nearest foot*, how close to the rocks the ship is at the time of the second sighting.
361. While sailing a boat offshore, Donna sees a lighthouse and calculates that the angle of elevation to the top of the lighthouse is  $3^\circ$ , as shown in the accompanying diagram. When she sails her boat 700 feet closer to the lighthouse, she finds that the angle of elevation is now  $5^\circ$ . How tall, to the *nearest tenth of a foot*, is the lighthouse?

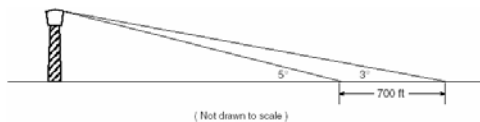

362. A sign 46 feet high is placed on top of an office building. From a point on the sidewalk level with the base of the building, the angle of elevation to the top of the sign and the angle of elevation to the bottom of the sign are  $40^\circ$  and  $32^\circ$ , respectively. Sketch a diagram to represent the building, the sign, and the two angles, and find the height of the building to the *nearest foot*.

## MATH TOOLBOX P. 449

### USING TRIGONOMETRY TO SOLVE TRIANGLE INEQUALITIES

363. How many distinct triangles can be formed if  $m\angle A = 30^\circ$ , side  $b = 12$ , and side  $a = 8$ ?  
[A] 3 [B] 2 [C] 0 [D] 1
364. What is the total number of distinct triangles that can be constructed if  $AC = 13$ ,  $BC = 8$ , and  $m\angle A = 36^\circ$ ?  
[A] 2 [B] 3 [C] 0 [D] 1
365. An architect commissions a contractor to produce a triangular window. The architect describes the window as  $\triangle ABC$ , where  $m\angle A = 50^\circ$ ,  $BC = 10$  inches, and  $AB = 12$  inches. How many distinct triangles can the contractor construct using these dimensions?  
[A] more than 2 [B] 1 [C] 2 [D] 0
366. Sam is designing a triangular piece for a metal sculpture. He tells Martha that two of the sides of the piece are 40 inches and 15 inches, and the angle opposite the 40-inch side measures  $120^\circ$ . Martha decides to sketch the piece that Sam described. How many different triangles can she sketch that match Sam's description?  
[A] 1 [B] 0 [C] 3 [D] 2
367. Sam needs to cut a triangle out of a sheet of paper. The only requirements that Sam must follow are that one of the angles must be  $60^\circ$ , the side opposite the  $60^\circ$  angle must be 40 centimeters, and one of the other sides must be 15 centimeters. How many different triangles can Sam make?  
[A] 1 [B] 3 [C] 2 [D] 0

368. A landscape designer is designing a triangular garden with two sides that are 4 feet and 6 feet, respectively. The angle opposite the 4-foot side is  $30^\circ$ . How many distinct triangular gardens can the designer make using these measurements?
369. Main Street and Central Avenue intersect, making an angle measuring  $34^\circ$ . Angela lives at the intersection of the two roads, and Caitlin lives on Central Avenue 10 miles from the intersection. If Leticia lives 7 miles from Caitlin, which conclusion is valid?
- [A] Leticia can live at one of two locations on Main Street.
- [B] Leticia cannot live on Main Street.
- [C] Leticia can live at only one location on Main Street.
- [D] Leticia can live at one of three locations on Main Street.
370. In  $\triangle ABC$ , if  $AC = 12$ ,  $BC = 11$ , and  $m\angle A = 30$ , angle  $C$  could be
- [A] an acute angle, only
- [B] a right angle, only
- [C] an obtuse angle, only
- [D] either an obtuse angle or an acute angle
371. In  $\triangle ABC$ ,  $m\angle A = 30$ ,  $a = 14$ , and  $b = 20$ . Which type of angle is  $\angle B$ ?
- [A] It must be a right angle.
- [B] It must be an acute angle.
- [C] It must be an obtuse angle.
- [D] It may be either an acute angle or an obtuse angle.

## NY LESSONS 8 & 9

### TRIGONOMETRIC IDENTITIES

372. The expression  $\frac{1 - \cos^2 x}{\sin^2 x}$  is equivalent to
- [A]  $\sin x$  [B] 1 [C]  $\cos x$  [D]  $-1$
373. The expression  $(1 + \cos x)(1 - \cos x)$  is equivalent to
- [A]  $\sec^2 x$  [B] 1
- [C]  $\csc^2 x$  [D]  $\sin^2 x$
374. Express in simplest terms:  $\frac{2 - 2\sin^2 x}{\cos x}$
375. The expression  $\sin A + \frac{\cos^2 A}{\sin A}$  is equivalent to
- [A]  $\csc A$  [B]  $\sec A$
- [C] 1 [D]  $\sin A$
376. If  $\theta$  is a positive acute angle and  $\sin \theta = a$ , which expression represents  $\cos \theta$  in terms of  $a$ ?
- [A]  $\frac{1}{\sqrt{a}}$  [B]  $\frac{1}{\sqrt{1-a^2}}$
- [C]  $\sqrt{1-a^2}$  [D]  $\sqrt{a}$
377. The expression  $\frac{\tan \theta}{\sec \theta}$  is equivalent to
- [A]  $\cos \theta$  [B]  $\sin \theta$
- [C]  $\frac{\sin \theta}{\cos^2 \theta}$  [D]  $\frac{\cos^2 \theta}{\sin \theta}$

378. The expression  $\frac{\sec \theta}{\csc \theta}$  is equivalent to

- [A]  $\frac{\sin \theta}{\cos \theta}$                       [B]  $\frac{\cos \theta}{\sin \theta}$   
[C]  $\sin \theta$                               [D]  $\cos \theta$

379. A crate weighing  $w$  pounds sits on a ramp positioned at an angle of  $\theta$  with the horizontal. The forces acting on this crate are modeled by the equation  $Mw \cos \theta = w \sin \theta$ , where  $M$  is the coefficient of friction. What is an expression for  $M$  in terms of  $\theta$ ?

- [A]  $M = \cot \theta$                       [B]  $M = \csc \theta$   
[C]  $M = \sec \theta$                       [D]  $M = \tan \theta$

## NY LESSON 10

### SOLVING TRIGONOMETRIC EQUATIONS

380. A solution set of the equation  $5 \sin \theta + 3 = 3$  contains all multiples of

- [A]  $45^\circ$     [B]  $90^\circ$     [C]  $180^\circ$     [D]  $135^\circ$

381. Solve the following equation algebraically for all values of  $\theta$  in the interval  $0^\circ \leq \theta \leq 180^\circ$ .

$$2 \sin \theta - 1 = 0$$

382. An architect is using a computer program to design the entrance of a railroad tunnel. The outline of the opening is modeled by the function  $f(x) = 8 \sin x + 2$ , in the interval  $0 \leq x \leq \pi$ , where  $x$  is expressed in radians. Solve algebraically for all values of  $x$  in the interval  $0 \leq x \leq \pi$ , where the height of the opening,  $f(x)$ , is 6. Express your answer in terms of  $\pi$ .

If the  $x$ -axis represents the base of the tunnel, what is the maximum height of the entrance of the tunnel?

383. What value of  $x$  in the interval  $0^\circ \leq x \leq 180^\circ$  satisfies the equation  $\sqrt{3} \tan x + 1 = 0$ ?

- [A]  $150^\circ$     [B]  $-30^\circ$     [C]  $30^\circ$     [D]  $60^\circ$

384. Solve algebraically for all values of  $\theta$  in the interval  $0^\circ \leq \theta \leq 360^\circ$  that satisfy the equation

$$\frac{\sin^2 \theta}{1 + \cos \theta} = 1.$$

385. In the interval  $0^\circ \leq A \leq 360^\circ$ , solve for all values of  $A$  in the equation  $\cos 2A = -3 \sin A - 1$ .

386. Navigators aboard ships and airplanes use nautical miles to measure distance. The length of a nautical mile varies with latitude. The length of a nautical mile,  $L$ , in feet, on the latitude line  $\theta$  is given by the formula  $L = 6,077 - 31 \cos 2\theta$ .

Find, to the *nearest degree*, the angle  $\theta$ ,  $0 \leq \theta \leq 90^\circ$ , at which the length of a nautical mile is approximately 6,076 feet.

387. Find, to the *nearest degree*, all values of  $\theta$  in the interval  $0^\circ < \theta < 360^\circ$  that satisfy the equation  $3 \cos 2\theta + \sin \theta - 1 = 0$ .

388. If  $(\sec x - 2)(2 \sec x - 1) = 0$ , then  $x$  terminates in

- [A] Quadrants I and II, only  
[B] Quadrants I and IV, only  
[C] Quadrant I, only  
[D] Quadrants I, II, III, and IV

389. Find, to the *nearest degree*, all values of  $\theta$  in the interval  $0^\circ \leq \theta \leq 180^\circ$  that satisfy the equation  $8 \cos^2 \theta - 2 \cos \theta - 1 = 0$ .

390. What is a positive value of  $x$  for which

$$9^{-\cos x} = \frac{1}{3}?$$

- [A]  $30^\circ$     [B]  $45^\circ$     [C]  $60^\circ$     [D]  $90^\circ$

391. If  $\sin 6A = \cos 9A$ , then  $m\angle A$  is equal to

- [A] 36 [B] 6 [C] 54 [D]  $1\frac{1}{2}$

392. The average annual snowfall in a certain region is modeled by the function

$$S(t) = 20 + 10\cos\left(\frac{\pi}{5}t\right),$$

where  $S$  represents the

annual snowfall, in inches, and  $t$  represents the number of years since 1970. What is the minimum annual snowfall, in inches, for this region? In which years between 1970 and 2000 did the minimum amount of snow fall? [The use of the grid is optional.]

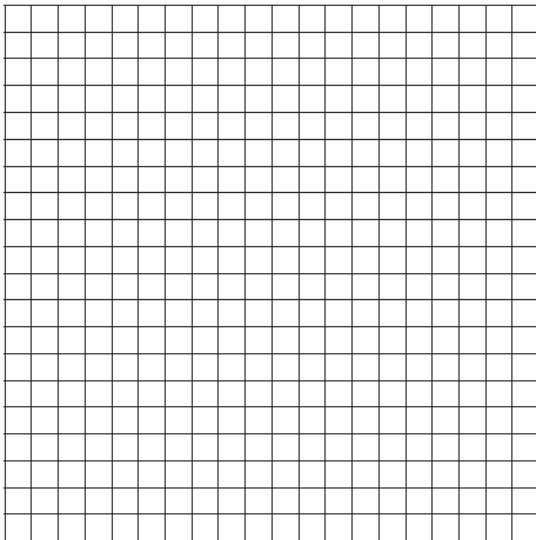

394. If  $x$  is an acute angle and  $\sin x = \frac{12}{13}$ , then  $\cos 2x$  equals

- [A]  $-\frac{119}{169}$  [B]  $-\frac{25}{169}$   
[C]  $\frac{25}{169}$  [D]  $\frac{119}{169}$

395. If  $\sin \theta = \frac{\sqrt{5}}{3}$ , then  $\cos 2\theta$  equals

- [A]  $-\frac{1}{3}$  [B]  $\frac{1}{3}$  [C]  $\frac{1}{9}$  [D]  $-\frac{1}{9}$

396. If  $\theta$  is an acute angle such that  $\sin \theta = \frac{5}{13}$ , what is the value of  $\sin 2\theta$ ?

- [A]  $\frac{12}{13}$  [B]  $\frac{60}{169}$  [C]  $\frac{10}{26}$  [D]  $\frac{120}{169}$

397. If  $\theta$  is a positive acute angle and  $\sin 2\theta = \frac{\sqrt{3}}{2}$ , then  $(\cos \theta + \sin \theta)^2$  equals

- [A]  $30^\circ$  [B]  $60^\circ$  [C] 1 [D]  $1 + \frac{\sqrt{3}}{2}$

398. If  $x$  is a positive acute angle and  $\sin x = \frac{1}{2}$ , what is  $\sin 2x$ ?

- [A]  $-\frac{1}{2}$  [B]  $\frac{1}{2}$  [C]  $\frac{\sqrt{3}}{2}$  [D]  $-\frac{\sqrt{3}}{2}$

399. The expression  $\frac{\sin 2\theta}{\sin^2 \theta}$  is equivalent to

- [A]  $2 \cot \theta$  [B]  $2 \tan \theta$   
[C]  $2 \cos \theta$  [D]  $\frac{2}{\sin \theta}$

## NY LESSON 11

### DOUBLE ANGLE AND ANGLE SUM AND DIFFERENCE IDENTITIES

393. If  $A$  is a positive acute angle and  $\sin A = \frac{\sqrt{5}}{3}$ , what is  $\cos 2A$ ?

- [A]  $\frac{1}{3}$  [B]  $-\frac{1}{9}$  [C]  $-\frac{1}{3}$  [D]  $\frac{1}{9}$

400. The expression  $\frac{2\cos\theta}{\sin 2\theta}$  is equivalent to
- [A]  $\sin \theta$                       [B]  $\sec \theta$   
[C]  $\cot \theta$                       [D]  $\csc \theta$
401. If  $\sin x = \frac{4}{5}$ , where  $0^\circ < x < 90^\circ$ , find the value of  $\cos(x + 180^\circ)$ .
402. If  $A$  and  $B$  are positive acute angles,  $\sin A = \frac{5}{13}$ , and  $\cos B = \frac{4}{5}$ , what is the value of  $\sin(A + B)$ ?
- [A]  $\frac{63}{65}$     [B]  $\frac{33}{65}$     [C]  $\frac{56}{65}$     [D]  $-\frac{16}{65}$
403. If  $\sin A = \frac{4}{5}$ ,  $\tan B = \frac{5}{12}$ , and angles  $A$  and  $B$  are in Quadrant I, what is the value of  $\sin(A + B)$ ?
- [A]  $\frac{63}{65}$     [B]  $-\frac{33}{65}$     [C]  $\frac{33}{65}$     [D]  $-\frac{63}{65}$
404. If  $\sin x = \frac{12}{13}$ ,  $\cos y = \frac{3}{5}$ , and  $x$  and  $y$  are acute angles, the value of  $\cos(x - y)$  is
- [A]  $-\frac{33}{65}$     [B]  $\frac{21}{65}$     [C]  $\frac{63}{65}$     [D]  $-\frac{14}{65}$
405. The expression  $\cos 40^\circ \cos 10^\circ + \sin 40^\circ \sin 10^\circ$  is equivalent to
- [A]  $\sin 30^\circ$                       [B]  $\cos 50^\circ$   
[C]  $\cos 30^\circ$                       [D]  $\sin 50^\circ$

## CHAPTER 10-3

### EQUATIONS OF CIRCLES

406. The center of a circular sunflower with a diameter of 4 centimeters is  $(-2, 1)$ . Which equation represents the sunflower?
- [A]  $(x - 2)^2 + (y + 1)^2 = 2$   
[B]  $(x + 2)^2 + (y - 1)^2 = 4$   
[C]  $(x - 2)^2 + (y - 1)^2 = 4$   
[D]  $(x + 2)^2 + (y - 1)^2 = 2$
407. What is the equation of a circle with center  $(-3, 1)$  and radius 7?
- [A]  $(x + 3)^2 + (y - 1)^2 = 49$   
[B]  $(x - 3)^2 + (y + 1)^2 = 7$   
[C]  $(x + 3)^2 + (y - 1)^2 = 7$   
[D]  $(x - 3)^2 + (y + 1)^2 = 49$
408. Which equation represents the circle shown in the accompanying graph?

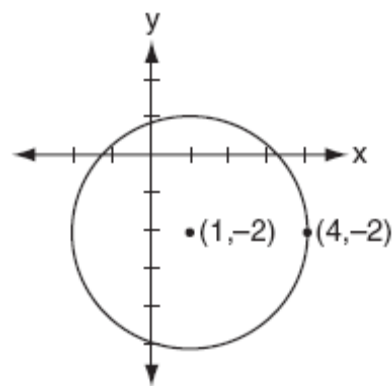

- [A]  $(x - 1)^2 + (y + 2)^2 = 9$   
[B]  $(x - 1)^2 - (y + 2)^2 = 9$   
[C]  $(x + 1)^2 - (y - 2)^2 = 9$   
[D]  $(x + 1)^2 + (y - 2)^2 = 9$

409. For a carnival game, John is painting two circles,  $V$  and  $M$ , on a square dartboard.  
a On the accompanying grid, draw and label circle  $V$ , represented by the equation  $x^2 + y^2 = 25$ , and circle  $M$ , represented by the equation  $(x - 8)^2 + (y + 6)^2 = 4$ .

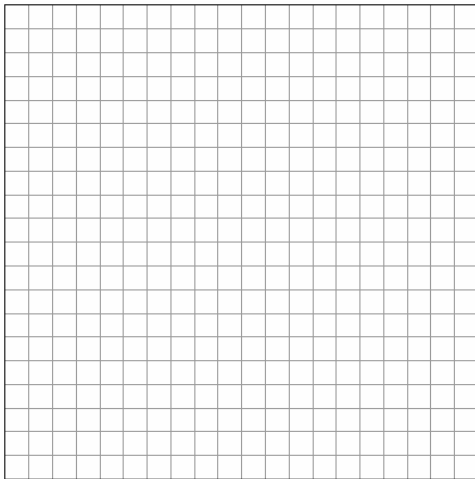

b A point,  $(x,y)$ , is randomly selected such that  $-10 \leq x \leq 10$  and  $-10 \leq y \leq 10$ . What is the probability that point  $(x,y)$  lies outside both circle  $V$  and circle  $M$ ?

410. A circle has the equation  $(x + 1)^2 + (y - 3)^2 = 16$ . What are the coordinates of its center and the length of its radius?  
[A]  $(-1,3)$  and 16      [B]  $(1,-3)$  and 4  
[C]  $(-1,3)$  and 4      [D]  $(1,-3)$  and 16
411. What are the coordinates of the center of the circle represented by the equation  $(x + 3)^2 + (y - 4)^2 = 25$ ?  
[A]  $(3,4)$       [B]  $(-3,4)$   
[C]  $(-3,-4)$       [D]  $(3,-4)$
412. The center of a circle represented by the equation  $(x - 2)^2 + (y + 3)^2 = 100$  is located in Quadrant  
[A] IV      [B] III      [C] I      [D] II

## CHAPTER 10-4

### EQUATIONS OF ELLIPSES

413. An object orbiting a planet travels in a path represented by the equation  $3(y + 1)^2 + 5(x + 4)^2 = 15$ . In which type of pattern does the object travel?  
[A] circle      [B] parabola  
[C] ellipse      [D] hyperbola
414. The accompanying diagram shows the elliptical orbit of a planet. The foci of the elliptical orbit are  $F_1$  and  $F_2$ .

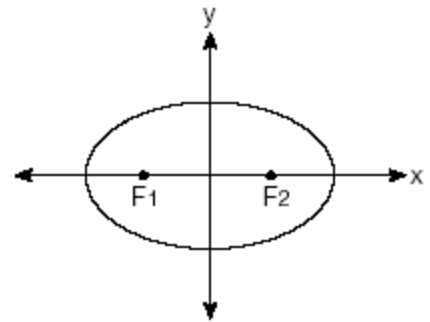

If  $a$ ,  $b$ , and  $c$  are all positive and  $a \neq b \neq c$ , which equation could represent the path of the planet?

- [A]  $ax^2 - by^2 = c^2$       [B]  $y = ax^2 + c^2$   
[C]  $x^2 + y^2 = c^2$       [D]  $ax^2 + by^2 = c^2$
415. Which equation, when graphed on a Cartesian coordinate plane, would best represent an elliptical racetrack?  
[A]  $3x^2 - 10y^2 = 288,000$   
[B]  $30xy = 288,000$   
[C]  $3x^2 + 10y^2 = 288,000$   
[D]  $3x + 10y = 288,000$

416. A designer who is planning to install an elliptical mirror is laying out the design on a coordinate grid. Which equation could represent the elliptical mirror?

- [A]  $x^2 + 4y^2 = 144$     [B]  $y = 4y^2 + 144$   
 [C]  $x^2 + y^2 = 144$     [D]  $x^2 = 144 + 36y^2$

417. The accompanying diagram represents the elliptical path of a ride at an amusement park.

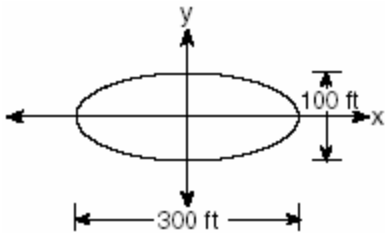

Which equation represents this path?

- [A]  $x^2 + y^2 = 300$     [B]  $\frac{x^2}{150^2} - \frac{y^2}{50^2} = 1$   
 [C]  $\frac{x^2}{150^2} + \frac{y^2}{50^2} = 1$   
 [D]  $y = x^2 + 100x + 300$

418. A commercial artist plans to include an ellipse in a design and wants the length of the horizontal axis to equal 10 and the length of the vertical axis to equal 6. Which equation could represent this ellipse?

- [A]  $3y = 20x^2$     [B]  $x^2 + y^2 = 100$   
 [C]  $9x^2 + 25y^2 = 225$   
 [D]  $9x^2 - 25y^2 = 225$

419. An architect is designing a building to include an arch in the shape of a semi-ellipse (half an ellipse), such that the width of the arch is 20 feet and the height of the arch is 8 feet, as shown in the accompanying diagram.

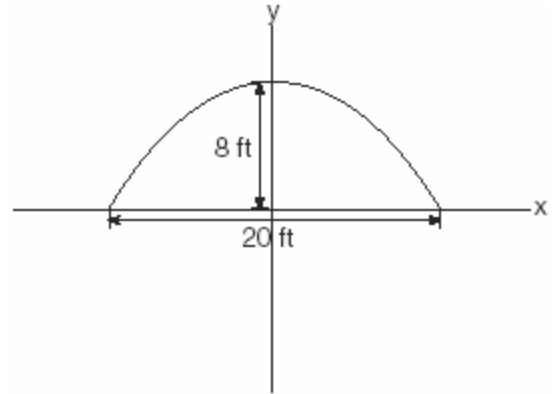

Which equation models this arch?

- [A]  $\frac{x^2}{400} + \frac{y^2}{64} = 1$     [B]  $\frac{x^2}{100} + \frac{y^2}{64} = 1$   
 [C]  $\frac{x^2}{64} + \frac{y^2}{400} = 1$     [D]  $\frac{x^2}{64} + \frac{y^2}{100} = 1$

420. The accompanying diagram shows the construction of a model of an elliptical orbit of a planet traveling around a star. Point  $P$  and the center of the star represent the foci of the orbit.

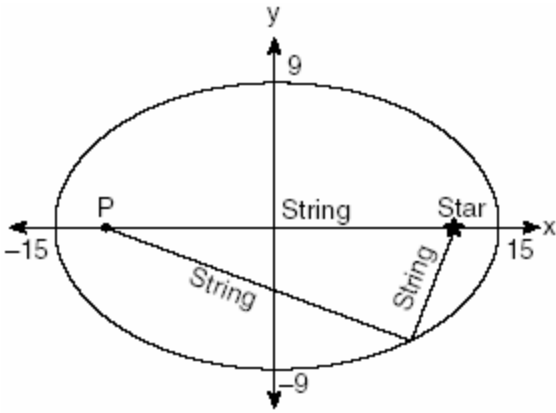

Which equation could represent the relation shown?

- [A]  $\frac{x^2}{225} + \frac{y^2}{81} = 1$       [B]  $\frac{x^2}{15} + \frac{y^2}{9} = 1$   
 [C]  $\frac{x^2}{81} + \frac{y^2}{225} = 1$       [D]  $\frac{x^2}{15} - \frac{y^2}{9} = 1$

421. A landscape architect is working on the plans for a new horse farm. He is laying out the exercise ring and racetrack on the accompanying graph. The location of the circular exercise ring, with point  $R$  as its center, has already been plotted.

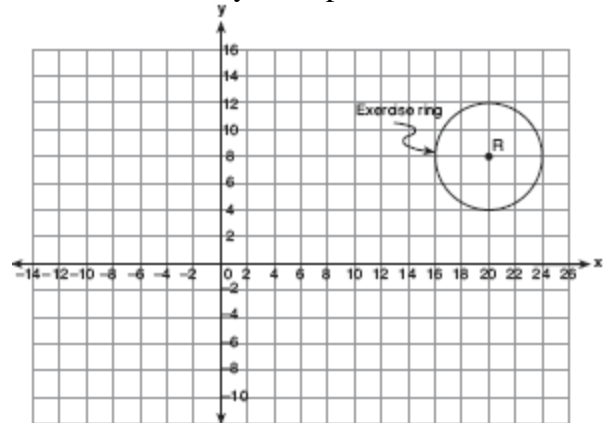

Write an equation that represents the outside edge of the exercise ring. The equation of the

outside edge of the racetrack is  $\frac{x^2}{144} + \frac{y^2}{36} = 1$ .

Sketch the outside edge of the racetrack on the graph.

### SOLVING NONLINEAR SYSTEMS

422. Solve the following system of equations algebraically:

$$9x^2 + y^2 = 9$$

$$3x - y = 3$$

## CHAPTER 11-3

### CENTRAL TENDENCY

423. Two social studies classes took the same current events examination that was scored on the basis of 100 points. Mr. Wong's class had a median score of 78 and a range of 4 points, while Ms. Rizzo's class had a median score of 78 and a range of 22 points. Explain how these classes could have the same median score while having very different ranges.



424. The accompanying graph shows the heart rate, in beats per minute, of a jogger during a 4-minute interval.

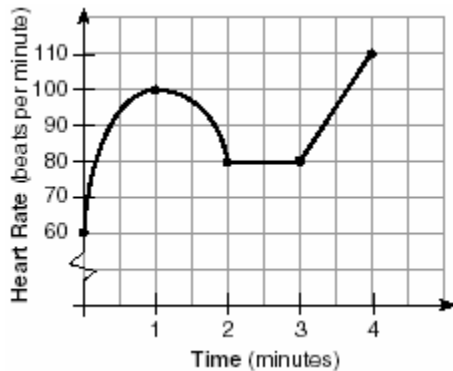

What is the range of the jogger's heart rate during this interval?

- [A] 60-110                      [B] 0-4  
[C] 1-4                              [D] 0-110
425. Data collected during an experiment are shown in the accompanying graph.

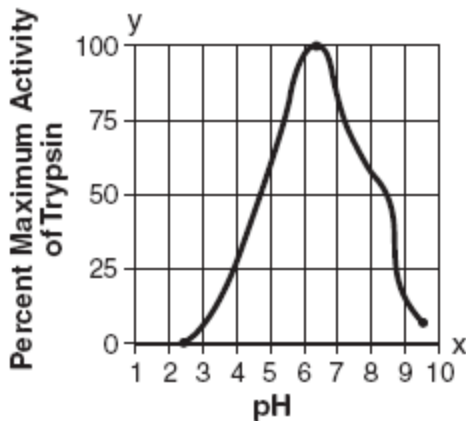

What is the range of this set of data?

- [A]  $1 \leq x \leq 10$                       [B]  $0 \leq y \leq 100$   
[C]  $2.5 \leq y \leq 9.5$                       [D]  $2.5 \leq x \leq 9.5$

426. The effect of pH on the action of a certain enzyme is shown on the accompanying graph.

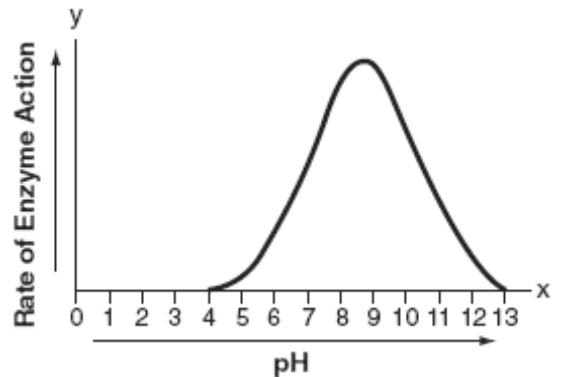

What is the domain of this function?

- [A]  $x \geq 0$                               [B]  $y \geq 0$   
[C]  $4 \leq x \leq 13$                       [D]  $4 \leq y \leq 13$

**CORRELATION COEFFICIENT**

427. A linear regression equation of best fit between a student's attendance and the degree of success in school is  $h = 0.5x + 68.5$ . The correlation coefficient,  $r$ , for these data would be
- [A]  $0 < r < 1$                               [B]  $-1 < r < 0$   
[C]  $r = 0$                                       [D]  $r = -1$
428. The relationship of a woman's shoe size and length of a woman's foot, in inches, is given in the accompanying table.

Woman's Shoe Size	5	6	7	8
Foot Length (in)	9.00	9.25	9.50	9.75

The linear correlation coefficient for this relationship is

- [A] 0                      [B] -1                      [C] 1                      [D] 0.5

429. Which scatter diagram shows the strongest positive correlation?

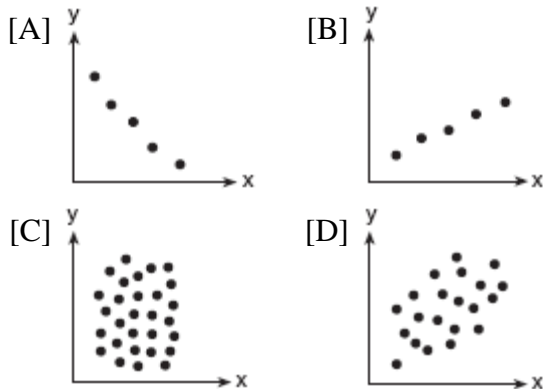

430. Which graph represents data used in a linear regression that produces a correlation coefficient closest to  $-1$ ?

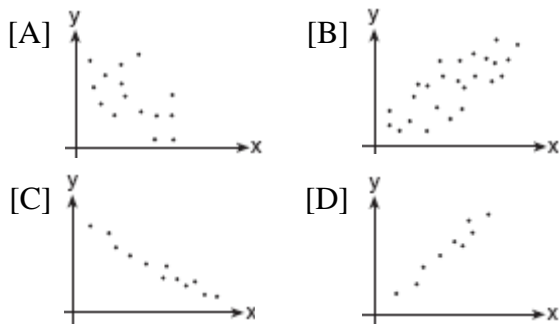

431. What could be the approximate value of the correlation coefficient for the accompanying scatter plot?

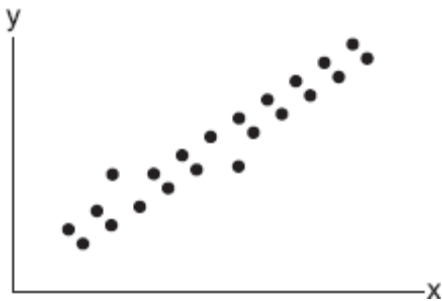

- [A] 0.21 [B] 0.90 [C] -0.16 [D] -0.85

## CHAPTER 11-4

### STANDARD DEVIATION

432. Jean's scores on five mathematics tests were 98, 97, 99, 98, and 96. Her scores on five English tests were 78, 84, 95, 72, and 79. Which statement is true about the standard deviations for the scores?

- [A] More information is needed to determine the relationship between the standard deviations.  
 [B] The standard deviation for the math scores is greater than the standard deviation for the English scores.  
 [C] The standard deviations for both sets of scores are equal.  
 [D] The standard deviation for the English scores is greater than the standard deviation for the math scores.

433. On a nationwide examination, the Adams School had a mean score of 875 and a standard deviation of 12. The Boswell School had a mean score of 855 and a standard deviation of 20. In which school was there greater consistency in the scores? Explain how you arrived at your answer.

434. The term "snowstorms of note" applies to all snowfalls over 6 inches. The snowfall amounts for snowstorms of note in Utica, New York, over a four-year period are as follows: 7.1, 9.2, 8.0, 6.1, 14.4, 8.5, 6.1, 6.8, 7.7, 21.5, 6.7, 9.0, 8.4, 7.0, 11.5, 14.1, 9.5, 8.6. What are the mean and population standard deviation for these data, to the *nearest hundredth*?

- [A] mean = 9.46; standard deviation = 3.85  
 [B] mean = 9.45; standard deviation = 3.74  
 [C] mean = 9.46; standard deviation = 3.74  
 [D] mean = 9.45; standard deviation = 3.85

435. The number of children of each of the first 41 United States presidents is given in the accompanying table. For this population, determine the mean and the standard deviation to the *nearest tenth*.  
How many of these presidents fall within one standard deviation of the mean?

Number of Children ( $x_i$ )	Number of Presidents ( $f_i$ )
0	6
1	2
2	8
3	6
4	7
5	3
6	5
7	1
8	1
10	1
15	1

436. Conant High School has 17 students on its championship bowling team. Each student bowled one game. The scores are listed in the accompanying table.

Score ( $x_i$ )	Frequency ( $f_i$ )
140	4
145	3
150	2
160	3
170	2
180	2
194	1

Find, to the *nearest tenth*, the population standard deviation of these scores. How many of the scores fall within one standard deviation of the mean?

437. Beth's scores on the six Earth science tests she took this semester are 100, 95, 55, 85, 75, and 100. For this population, how many scores are within one standard deviation of the mean?

438. From 1984 to 1995, the winning scores for a golf tournament were 276, 279, 279, 277, 278, 278, 280, 282, 285, 272, 279, and 278. Using the standard deviation for the sample,  $S_x$ , find the percent of these winning scores that fall within one standard deviation of the mean.

439. An electronics company produces a headphone set that can be adjusted to accommodate different-sized heads. Research into the distance between the top of people's heads and the top of their ears produced the following data, in inches:  
4.5, 4.8, 6.2, 5.5, 5.6, 5.4, 5.8, 6.0, 5.8, 6.2, 4.6, 5.0, 5.4, 5.8  
The company decides to design their headphones to accommodate three standard deviations from the mean. Find, to the *nearest tenth*, the mean, the standard deviation, and the range of distances that must be accommodated.

440. On a standardized test, a score of 86 falls exactly 1.5 standard deviations below the mean. If the standard deviation for the test is 2, what is the mean score for this test?

[A] 87.5 [B] 89 [C] 84.5 [D] 84

## CHAPTER 11-7

### NORMAL DISTRIBUTIONS

441. Twenty high school students took an examination and received the following scores:  
70, 60, 75, 68, 85, 86, 78, 72, 82, 88, 88, 73, 74, 79, 86, 82, 90, 92, 93, 73  
Determine what percent of the students scored within one standard deviation of the mean. Do the results of the examination approximate a normal distribution? Justify your answer.

442. Mrs. Ramírez is a real estate broker. Last month, the sale prices of homes in her area approximated a normal distribution with a mean of \$150,000 and a standard deviation of \$25,000.  
A house had a sale price of \$175,000. What is the percentile rank of its sale price, to the nearest whole number? Explain what that percentile means.  
Mrs. Ramírez told a customer that most of the houses sold last month had selling prices between \$125,000 and \$175,000. Explain why she is correct.
443. On a standardized test, the distribution of scores is normal, the mean of the scores is 75, and the standard deviation is 5.8. If a student scored 83, the student's score ranks
- [A] below the 75th percentile  
[B] above the 97th percentile  
[C] between the 75th percentile and the 84th percentile  
[D] between the 84th percentile and the 97th percentile
444. In a New York City high school, a survey revealed the mean amount of cola consumed each week was 12 bottles and the standard deviation was 2.8 bottles. Assuming the survey represents a normal distribution, how many bottles of cola per week will approximately 68.2% of the students drink?
- [A] 6.4 to 12                      [B] 12 to 20.4  
[C] 9.2 to 14.8                    [D] 6.4 to 17.6
445. The amount of juice dispensed from a machine is normally distributed with a mean of 10.50 ounces and a standard deviation of 0.75 ounce. Which interval represents the amount of juice dispensed about 68.2% of the time?
- [A] 9.00-12.00                    [B] 9.75-11.25  
[C] 10.50-11.25                    [D] 9.75-10.50
446. The mean of a normally distributed set of data is 56, and the standard deviation is 5. In which interval do approximately 95.4% of all cases lie?
- [A] 51-61                            [B] 46-66  
[C] 56-71                            [D] 46-56
447. The national mean for verbal scores on an exam was 428 and the standard deviation was 113. Approximately what percent of those taking this test had verbal scores between 315 and 541?
- [A] 26.4%                            [B] 38.2%  
[C] 68.2%                            [D] 52.8%
448. Battery lifetime is normally distributed for large samples. The mean lifetime is 500 days and the standard deviation is 61 days. Approximately what percent of batteries have lifetimes longer than 561 days?
- [A] 34%    [B] 84%    [C] 16%    [D] 68%
449. The amount of ketchup dispensed from a machine at Hamburger Palace is normally distributed with a mean of 0.9 ounce and a standard deviation of 0.1 ounce. If the machine is used 500 times, approximately how many times will it be expected to dispense 1 or more ounces of ketchup?
- [A] 16    [B] 100    [C] 80    [D] 5
450. Professor Bartrich has 184 students in her mathematics class. The scores on the final examination are normally distributed and have a mean of 72.3 and a standard deviation of 8.9. How many students in the class can be expected to receive a score between 82 and 90?

451. In a certain school district, the ages of all new teachers hired during the last 5 years are normally distributed. Within this curve, 95.4% of the ages, centered about the mean, are between 24.6 and 37.4 years. Find the mean age and the standard deviation of the data.

452. The mean score on a normally distributed exam is 42 with a standard deviation of 12.1. Which score would be expected to occur less than 5% of the time?

- [A] 32    [B] 25    [C] 60    [D] 67

**NORMAL PROBABILITY**

453. A set of normally distributed student test scores has a mean of 80 and a standard deviation of 4. Determine the probability that a randomly selected score will be between 74 and 82.

454. The amount of time that a teenager plays video games in any given week is normally distributed. If a teenager plays video games an average of 15 hours per week, with a standard deviation of 3 hours, what is the probability of a teenager playing video games between 15 and 18 hours a week?

455. A shoe manufacturer collected data regarding men's shoe sizes and found that the distribution of sizes exactly fits the normal curve. If the mean shoe size is 11 and the standard deviation is 1.5, find:

*a* the probability that a man's shoe size is greater than or equal to 11

*b* the probability that a man's shoe size is greater than or equal to 12.5

*c*  $\frac{P(\text{size} \geq 12.5)}{P(\text{size} \geq 8)}$

**CHAPTER 12-4**

**SUMMATIONS**

456. Evaluate:  $2 \sum_{n=1}^5 (2n - 1)$

457. What is the value of  $\sum_{n=1}^5 (-2n + 100)$ ?

- [A] 530    [B] 130    [C] 470    [D] 70

458. What is the value of  $\sum_{m=2}^5 (m^2 - 1)$ ?

- [A] 58    [B] 50    [C] 53    [D] 54

459. Evaluate:  $\sum_{n=1}^5 (n^2 + n)$

460. What is the value of  $\sum_{m=1}^3 (2m + 1)^{m-1}$ ?

- [A] 245    [B] 57    [C] 55    [D] 15

461. The projected total annual profits, in dollars, for the Nutyme Clothing Company from 2002 to 2004 can be approximated by the model  $\sum_{n=0}^2 (13,567n + 294)$ , where *n* is the year and *n* = 0 represents 2002. Use this model to find the company's projected total annual profits, in dollars, for the period 2002 to 2004.

462. A ball is dropped from a height of 8 feet and allowed to bounce. Each time the ball bounces, it bounces back to half its previous height. The vertical distance the ball travels, *d*, is given by the formula  $d = 8 + 16 \sum_{k=1}^n \left(\frac{1}{2}\right)^k$ ,

where *n* is the number of bounces. Based on this formula, what is the total vertical distance that the ball has traveled after four bounces?

- [A] 15.0 ft    [B] 23.0 ft  
[C] 22.0 ft    [D] 8.9 ft

463. Evaluate:  $\sum_{k=1}^2 \frac{(-1)^{k-1}}{(2k-1)!}$

464. If  ${}_n C_r$  represents the number of combinations of  $n$  items taken  $r$  at a time, what is the value of  $\sum_{r=1}^3 {}_4 C_r$ ?

- [A] 4      [B] 24      [C] 6      [D] 14

465. The value of  $\sum_{r=2}^4 {}_5 C_r$  is

- [A] 45      [B] 25      [C] 10      [D] 5

466. Evaluate:  $\sum_{k=0}^3 (3 \cos k\pi + 1)$

467. What is the value of  $\sum_{b=0}^3 (2 - (b)i)$ ?

- [A]  $2-6i$     [B]  $8-6i$     [C]  $2-5i$     [D]  $8-5i$

468. Jonathan's teacher required him to express the sum  $\frac{2}{3} + \frac{3}{4} + \frac{4}{5} + \frac{5}{6} + \frac{6}{7}$  using sigma notation.

Jonathan proposed four possible answers. Which of these four answers is *not* correct?

[A]  $\sum_{k=1}^5 \frac{k+1}{k+2}$       [B]  $\sum_{k=3}^7 \frac{k-1}{k}$

[C]  $\sum_{k=2}^6 \frac{k}{k+1}$       [D]  $\sum_{k=1}^5 \frac{k}{k+1}$

469. The expression  $1 + \sqrt{2} + \sqrt[3]{3}$  is equivalent to

[A]  $\sum_{n=1}^3 n^{\frac{1}{n}}$       [B]  $\sum_{n=1}^3 n^{-n}$

[C]  $\sum_{n=1}^3 \sqrt[n]{n}$       [D]  $\sum_{n=0}^3 n^n$