

# JEFFERSON MATH PROJECT

## REGENTS BY CHAPTER

All 1165 NY Math A & B Regents Exam Questions from  
June 1999 to August 2005 Sorted by Prentice Hall Chapter  
ALGEBRA

[www.jmap.org](http://www.jmap.org)



*Dear Sir*

*I have to acknowledge the receipt of your favor of May 14. in which you mention that you have finished the 6. first books of Euclid, plane trigonometry, surveying & algebra and ask whether I think a further pursuit of that branch of science would be useful to you. there are some propositions in the latter books of Euclid, & some of Archimedes, which are useful, & I have no doubt you have been made acquainted with them. trigonometry, so far as this, is most valuable to every man, there is scarcely a day in which he will not resort to it for some of the purposes of common life. the science of calculation also is indispensable as far as the extraction of the square & cube roots; Algebra as far as the quadratic equation & the use of logarithms are often of value in ordinary cases: but all beyond these is but a luxury; a delicious luxury indeed; but not to be indulged in by one who is to have a profession to follow for his subsistence. in this light I view the conic sections, curves of the higher orders, perhaps even spherical trigonometry, Algebraical operations beyond the 2d dimension, and fluxions.*

Letter from Thomas Jefferson to William G. Munford, Monticello, June 18, 1799.

# TABLE OF CONTENTS

## ALGEBRA

	PRENTICE HALL CHAPTER	NUMBER OF REGENTS QUESTIONS	PAGE
1	Tools of Algebra	94	1
2	Functions and Their Graphs	19	12
3	Algebraic Concepts and Simple Equations	37	15
4	Equations and Inequalities	67	18
5	Graphing and Writing Linear Equations	31	25
6	Systems of Equations and Inequalities	44	30
7	Quadratic Equations and Functions	14	38
8	Exponents and Exponential Functions	35	42
9	Right Triangles and Radical Expressions	65	44
10	Polynomials	46	53
11	Rational Expressions and Functions	56	57
		508	

## ALGEBRA CHAPTER 1-1

- From January 3 to January 7, Buffalo recorded the following daily high temperatures:  $5^{\circ}$ ,  $7^{\circ}$ ,  $6^{\circ}$ ,  $5^{\circ}$ , and  $7^{\circ}$ . Which statement about the temperatures is true?  
[A] median = mode [B] mean = median  
[C] mean < median [D] mean = mode
- The ages of five children in a family are 3, 3, 5, 8, and 18. Which statement is true for this group of data?  
[A] median > mean [B] mode > mean  
[C] median = mode [D] mean > median
- Rosario and Enrique are in the same mathematics class. On the first five tests, Rosario received scores of 78, 77, 64, 86, and 70. Enrique received scores of 90, 61, 79, 73, and 87. How much higher was Enrique's average than Rosario's average?  
[A] 3 points [B] 15 points  
[C] 4 points [D] 2 points
- On an English examination, two students received scores of 90, five students received 85, seven students received 75, and one student received 55. The average score on this examination was  
[A] 77 [B] 79 [C] 76 [D] 75

- What was the median high temperature in Middletown during the 7-day period shown in the table below?

Day	Temperature ( $^{\circ}$ F)
Sunday	68
Monday	73
Tuesday	73
Wednesday	75
Thursday	69
Friday	67
Saturday	63

- [A] 75 [B] 70 [C] 73 [D] 69

- The student scores on Mrs. Frederick's mathematics test are shown on the stem-and-leaf plot below.

4	3								
6	0	5	5	7	9				
7	2	5	6	8	9	9	9		
9	0	1	2	5	9				

Key: 4 | 3 = 43 points

Find the median of these scores.

- Jorge made the accompanying stem-and-leaf plot of the weights, in pounds, of each member of the wrestling team he was coaching.

Stem	Leaf
10	9
11	
12	3 8
13	2 4 4 6 8
14	1 3 5 5 9
15	2 3 7 7 9
16	1 3 7 8 8 8 9
17	3 8

Key: 16 | 1 = 161

What is the mode of the weights?

- [A] 168 [B] 152 [C] 150 [D] 145

8. The weights of all the students in grade 9 are arranged from least to greatest. Which statistical measure separates the top half of this set of data from the bottom half?

[A] mode                      [B] median  
[C] mean                      [D] average

9. Seth bought a used car that had been driven 20,000 miles. After he owned the car for 2 years, the total mileage of the car was 49,400. Find the average number of miles he drove *each month* during those 2 years.

10. What is the mean of the data in the accompanying table?

Scores ( $x_i$ )	Frequency ( $f_i$ )
25	3
20	2
11	5
10	4

[A] 16    [B] 14.5    [C] 11    [D] 15

11. The mean (average) weight of three dogs is 38 pounds. One of the dogs, Sparky, weighs 46 pounds. The other two dogs, Eddie and Sandy, have the same weight. Find Eddie's weight.

12. If 6 and  $x$  have the same mean (average) as 2, 4, and 24, what is the value of  $x$ ?

[A] 14    [B] 36    [C] 5    [D] 10

13. During each marking period, there are five tests. If Vanita needs a 65 average to pass this marking period and her first four grades are 60, 72, 55, and 80, what is the *lowest* score she can earn on the last test to have a passing average?

[A] 80    [B] 100    [C] 58    [D] 65

14. The exact average of a set of six test scores is 92. Five of these scores are 90, 98, 96, 94, and 85. What is the other test score?

[A] 91    [B] 86    [C] 89    [D] 92

15. TOP Electronics is a small business with five employees. The mean (average) weekly salary for the five employees is \$360. If the weekly salaries of four of the employees are \$340, \$340, \$345, and \$425, what is the salary of the fifth employee?

16. The students in Woodland High School's meteorology class measured the noon temperature every schoolday for a week. Their readings for the first 4 days were Monday,  $56^\circ$ ; Tuesday,  $72^\circ$ ; Wednesday,  $67^\circ$ ; and Thursday,  $61^\circ$ . If the mean (average) temperature for the 5 days was exactly  $63^\circ$ , what was the temperature on Friday?

17. For five algebra examinations, Maria has an average of 88. What must she score on the sixth test to bring her average up to exactly 90?

[A] 98    [B] 94    [C] 92    [D] 100

18. Judy needs a mean (average) score of 86 on four tests to earn a midterm grade of B. If the mean of her scores for the first three tests was 83, what is the *lowest* score on a 100-point scale that she can receive on the fourth test to have a midterm grade of B?

19. Tamika could not remember her scores from five mathematics tests. She did remember that the mean (average) was exactly 80, the median was 81, and the mode was 88. If all her scores were integers with 100 the highest score possible and 0 the lowest score possible, what was the *lowest* score she could have received on any one test?

20. On the first six tests in her social studies course, Jerelyn's scores were 92, 78, 86, 92, 95, and 91. Determine the median and the mode of her scores. If Jerelyn took a seventh test and raised the mean of her scores exactly 1 point, what was her score on the seventh test?

21. The test scores for 10 students in Ms. Sampson's homeroom were 61, 67, 81, 83, 87, 88, 89, 90, 98, and 100. Which frequency table is accurate for this set of data?

[A] 

Interval	Frequency
61-70	2
71-80	0
81-90	8
91-100	10

[B] 

Interval	Frequency
61-70	2
71-80	2
81-90	8
91-100	10

[C] 

Interval	Frequency
61-70	2
71-80	2
81-90	7
91-100	10

[D] 

Interval	Frequency
61-70	2
71-80	0
81-90	6
91-100	2

22. The following set of data represents the scores on a mathematics quiz:  
 58, 79, 81, 99, 68, 92, 76, 84, 53, 57, 81, 91, 77, 50, 65, 57, 51, 72, 84, 89  
 Complete the frequency table below and, on the accompanying grid, draw and label a frequency histogram of these scores.

Mathematics Quiz Scores

Interval	Tally	Frequency
50-59		
60-69		
70-79		
80-89		
90-99		

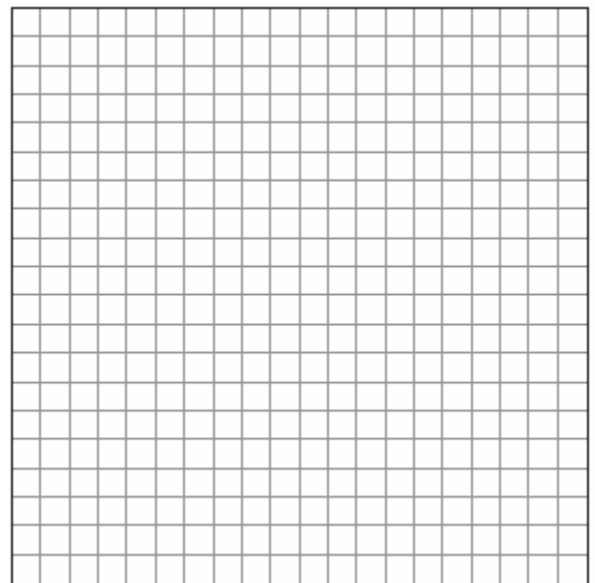

23. The scores on a mathematics test were 70, 55, 61, 80, 85, 72, 65, 40, 74, 68, and 84. Complete the accompanying table, and use the table to construct a frequency histogram for these scores.

Score	Tally	Frequency
40-49		
50-59		
60-69		
70-79		
80-89		

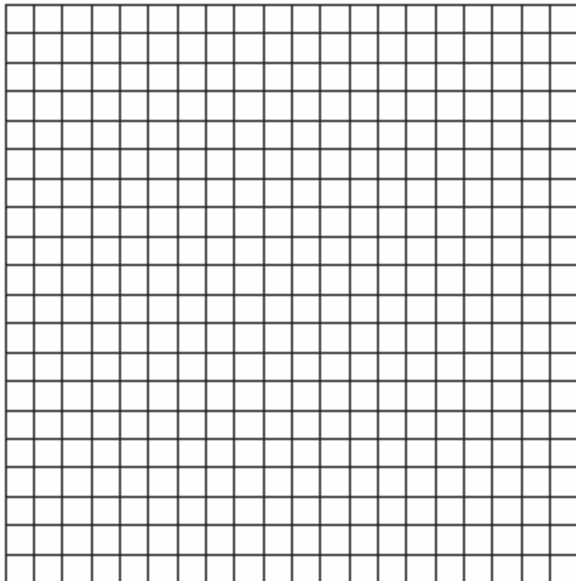

24. On a science quiz, 20 students received the following scores: 100, 95, 95, 90, 85, 85, 85, 80, 80, 80, 80, 75, 75, 75, 70, 70, 65, 65, 60, 55. Construct a statistical graph, such as a histogram or a stem-and-leaf plot, to display this data. [Be sure to title the graph and label all axes or parts used.] If your type of plot requires a grid, show your work here.

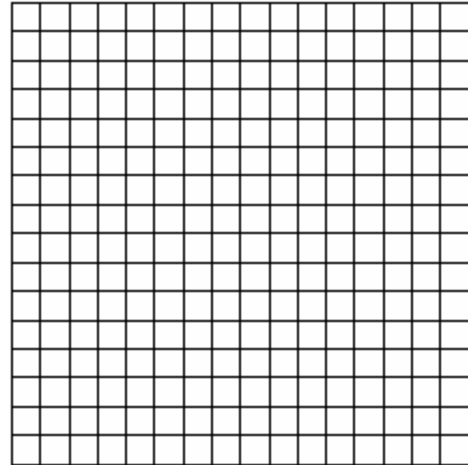

If no grid is necessary, show your work here.

25. In the time trials for the 400-meter run at the state sectionals, the 15 runners recorded the times shown in the table below.

400-Meter Run	
Time (sec)	Frequency
50.0–50.9	
51.0–51.9	
52.0–52.9	
53.0–53.9	
54.0–54.9	

a Using the data from the frequency column, draw a frequency histogram on the grid provided below.

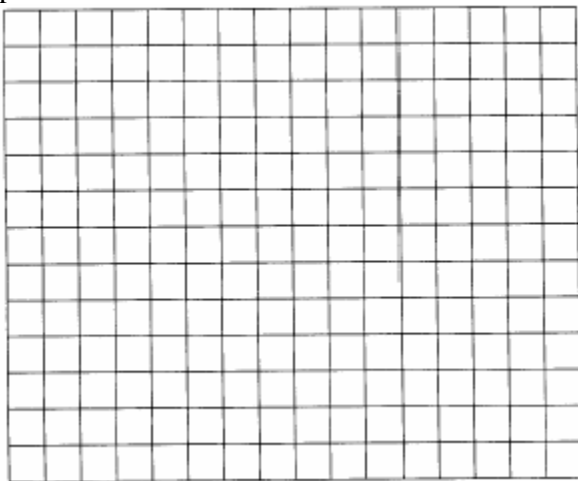

b What percent of the runners completed the time trial between 52.0 and 53.9 seconds?

26. The following data consists of the weights, in pounds, of 30 adults:

195, 206, 100, 98, 150, 210, 195, 106, 195, 168, 180, 212, 104, 195, 100, 216, 195, 209, 112, 99, 206, 116, 195, 100, 142, 100, 135, 98, 160, 155

Using the data, complete the accompanying cumulative frequency table and construct a cumulative frequency histogram on the grid below.

Interval	Frequency	Cumulative Frequency
51–100		
101–150		
151–200		
201–250		

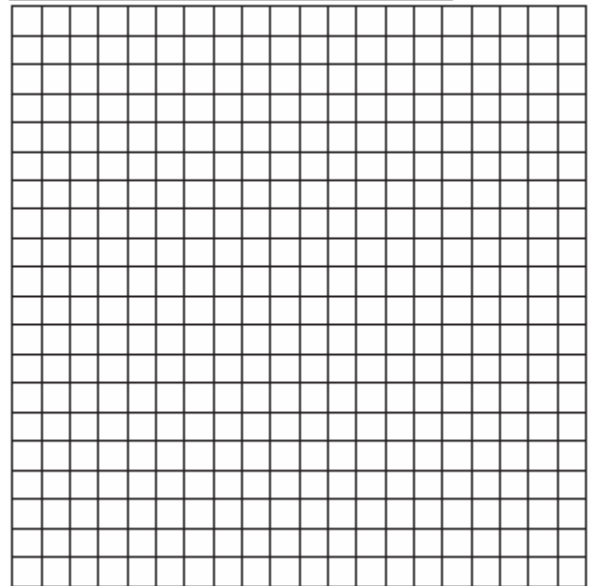

27. Sarah's mathematics grades for one marking period were 85, 72, 97, 81, 77, 93, 100, 75, 86, 70, 96, and 80.

a. Complete the tally sheet and frequency table below, and construct and label a frequency histogram for Sarah's grades using the accompanying grid.

Interval (grades)	Tally	Frequency
61–70		
71–80		
81–90		
91–100		

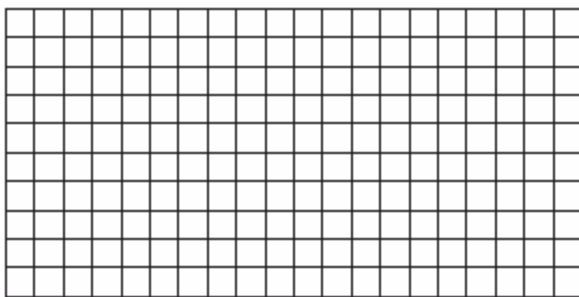

b. Which interval contains the 75th percentile (upper quartile)?

28. The accompanying histogram shows the heights of the students in Kyra's health class.

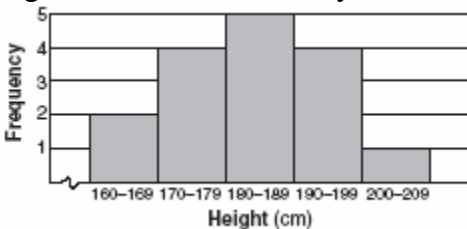

What is the total number of students in the class?

- [A] 209    [B] 16    [C] 5    [D] 15

29. Construct a stem-and-leaf plot listing the scores below in order from lowest to highest. 15, 25, 28, 32, 39, 40, 43, 26, 50, 75, 65, 19, 55, 72, 50

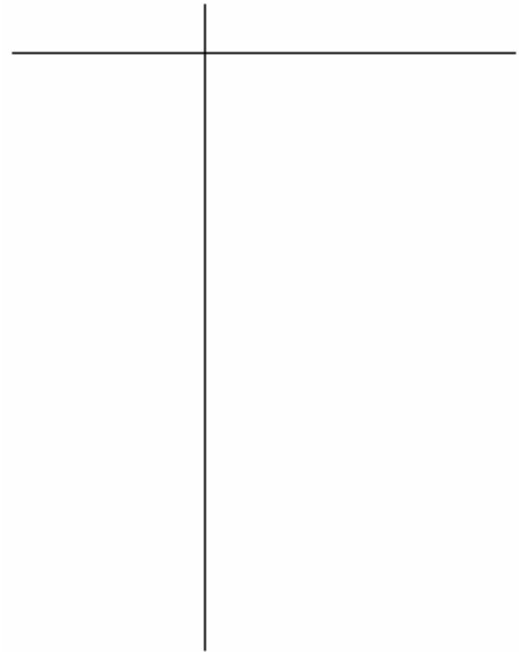

30. The accompanying diagram shows a box-and-whisker plot of student test scores on last year's Mathematics A midterm examination.

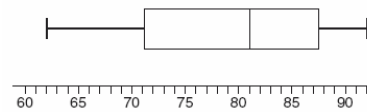

What is the median score?

- [A] 92    [B] 81    [C] 71    [D] 62

31. The accompanying diagram is an example of which type of graph?

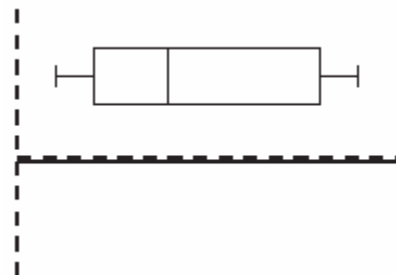

- [A] histogram    [B] box-and-whisker plot  
[C] stem-and-leaf plot    [D] bar graph



## ALGEBRA CHAPTER 1-2

32. Which expression represents the number of yards in  $x$  feet?
- [A]  $12x$    [B]  $\frac{x}{12}$    [C]  $\frac{x}{3}$    [D]  $3x$
33. If rain is falling at the rate of 2 inches per hour, how many inches of rain will fall in  $x$  minutes?
- [A]  $\frac{x}{30}$    [B]  $\frac{60}{x}$    [C]  $2x$    [D]  $\frac{30}{x}$
34. A car travels 110 miles in 2 hours. At the same rate of speed, how far will the car travel in  $h$  hours?
- [A]  $\frac{h}{55}$    [B]  $220h$    [C]  $\frac{h}{220}$    [D]  $55h$
35. Tara buys two items that cost  $d$  dollars each. She gives the cashier \$20. Which expression represents the change she should receive?
- [A]  $20 - d$    [B]  $20 - 2d$   
[C]  $2d - 20$    [D]  $20 + 2d$
36. The sum of Scott's age and Greg's age is 33 years. If Greg's age is represented by  $g$ , Scott's age is represented by
- [A]  $33g$    [B]  $g - 33$   
[C]  $33 - g$    [D]  $g + 33$
37. A store advertises that during its Labor Day sale \$15 will be deducted from every purchase over \$100. In addition, after the deduction is taken, the store offers an early-bird discount of 20% to any person who makes a purchase before 10 a.m. If Hakeem makes a purchase of  $x$  dollars,  $x > 100$ , at 8 a.m., what, in terms of  $x$ , is the cost of Hakeem's purchase?
- [A]  $0.80x - 12$    [B]  $0.20x - 3$   
[C]  $0.20x - 15$    [D]  $0.85x - 20$

## ALGEBRA CHAPTER 1-3

38. If the expression  $3 - 4^2 + \frac{6}{2}$  is evaluated, what would be done *last*?
- [A] subtracting   [B] squaring  
[C] adding   [D] dividing
39. The expression  $15 - 3[2 + 6(-3)]$  simplifies to
- [A] -45   [B] 192   [C] -33   [D] 63
40. Brett was given the problem: "Evaluate  $2x^2 + 5$  when  $x = 3$ ." Brett wrote that the answer was 41. Was Brett correct? Explain your answer.
41. If  $x = -4$  and  $y = 3$ , what is the value of  $x - 3y^2$ ?
- [A] -31   [B] -85   [C] -13   [D] -23
42. If  $t = -3$ , then  $3t^2 + 5t + 6$  equals
- [A] -36   [B] 6   [C] -6   [D] 18
43. What is the value of  $\frac{x^2 - 4y}{2}$ , if  $x = 4$  and  $y = -3$ ?
- [A] -2   [B] 14   [C] 2   [D] 10

## ALGEBRA CHAPTER 1-4

44. On February 18, from 9 a.m. until 2 p.m., the temperature rose from  $-14^\circ\text{F}$  to  $36^\circ\text{F}$ . What was the total increase in temperature during this time period?
- [A]  $22^\circ$    [B]  $32^\circ$    [C]  $50^\circ$    [D]  $36^\circ$
45. If the number represented by  $n-3$  is an odd integer, which expression represents the next greater odd integer?
- [A]  $n - 5$    [B]  $n + 1$    [C]  $n - 2$    [D]  $n - 1$

## ALGEBRA CHAPTER 1-6

46. If  $n + 4$  represents an odd integer, the next larger odd integer is represented by  
[A]  $n + 3$  [B]  $n + 6$   
[C]  $n + 2$  [D]  $n + 5$
47. If  $n$  represents an odd number, which computation results in an answer that is an even number?  
[A]  $3 \times n - 2$  [B]  $2 \times n - 1$   
[C]  $3 \times n + 1$  [D]  $2 \times n + 1$
48. If  $a$  is an odd number,  $b$  an even number, and  $c$  an odd number, which expression will always be equivalent to an odd number?  
[A]  $a(bc)$  [B]  $ac(b)^0$   
[C]  $ac(b)^1$  [D]  $ac(b)^2$
49. If  $a$  and  $b$  are both odd integers, which expression must always equal an odd integer?  
[A]  $a - b$  [B]  $\frac{a}{b}$  [C]  $a \cdot b$  [D]  $a + b$
50. Tom scored 23 points in a basketball game. He attempted 15 field goals and 6 free throws. If each successful field goal is 2 points and each successful free throw is 1 point, is it possible he successfully made all 6 of his free throws? Justify your answer.
51. The expression  $-|-7|$  is equivalent to  
[A] 1 [B] 7 [C] -7 [D] 0
52. If  $r = 2$  and  $s = -7$ , what is the value of  $|r| - |s|$ ?  
[A] 9 [B] -5 [C] -9 [D] 5
53. The number 0.14114111411114... is  
[A] rational [B] integral  
[C] whole [D] irrational
54. Which number is rational?  
[A]  $\frac{5}{4}$  [B]  $\pi$  [C]  $\sqrt{\frac{3}{2}}$  [D]  $\sqrt{7}$
55. Which number is irrational?  
[A]  $\frac{2}{3}$  [B]  $\sqrt{9}$  [C] 0.3333 [D]  $\sqrt{8}$
56. Which expression represents an irrational number?  
[A]  $\sqrt{2}$  [B] 0.17 [C] 0 [D]  $\frac{1}{2}$
57. Which is an irrational number?  
[A]  $\sqrt{3}$  [B] 3.14 [C]  $\sqrt{9}$  [D]  $\frac{3}{4}$
58. Which is an irrational number?  
[A]  $\pi$  [B] 0 [C]  $\sqrt{9}$  [D]  $-\frac{1}{3}$
59. Which is a rational number?  
[A]  $\pi$  [B]  $\sqrt{8}$  [C]  $6\sqrt{2}$  [D]  $5\sqrt{9}$
60. Which expression is rational?  
[A]  $\sqrt{3}$  [B]  $\pi$  [C]  $\sqrt{\frac{1}{2}}$  [D]  $\sqrt{\frac{1}{4}}$
61. Which is an irrational number?  
[A]  $\pi$  [B]  $\frac{3}{8}$  [C]  $0.\bar{3}$  [D]  $\sqrt{49}$

62. Which number below is irrational?

$$\sqrt{\frac{4}{9}}, \sqrt{20}, \sqrt{121}$$

Why is the number you chose an irrational number?

63. Given:  $\frac{\sqrt{99}}{11}$ ,  $\sqrt{164}$ ,  $\sqrt{196}$

Identify the expression that is a rational number and explain why it is rational.

64. If  $t^2 < t < \sqrt{t}$ , then  $t$  could be

[A] 0      [B] 4      [C]  $\frac{1}{4}$       [D]  $-\frac{1}{4}$

65. Let  $x$  and  $y$  be numbers such that  $0 < x < y < 1$ , and let  $d = x - y$ . Which graph could represent the location of  $d$  on the number line?

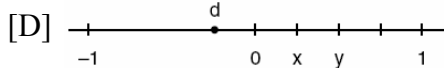
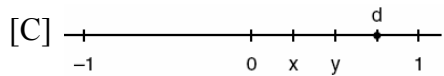
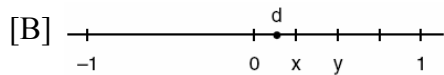
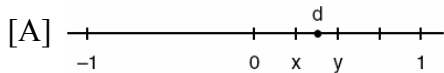

66. If  $a < b$ ,  $c < d$ , and  $a$ ,  $b$ ,  $c$ , and  $d$  are all greater than 0, which expression is always true?

[A]  $a + c > b + d$       [B]  $ac < bd$   
[C]  $a - c + b - d = 0$       [D]  $\frac{a}{d} > \frac{b}{c}$

67. Kyoko's mathematics teacher gave her the accompanying cards and asked her to arrange the cards in order from least to greatest. In what order should Kyoko arrange the cards?

$\pi$	$\sqrt{8}$	$3.\bar{1}$	$2\sqrt{3}$	$2\frac{4}{5}$
-------	------------	-------------	-------------	----------------

68. In which list are the numbers in order from least to greatest?

[A]  $3.2, \pi, 3\frac{1}{3}, \sqrt{3}$       [B]  $3.2, 3\frac{1}{3}, \sqrt{3}, \pi$

[C]  $\sqrt{3}, 3.2, \pi, 3\frac{1}{3}$       [D]  $\sqrt{3}, \pi, 3.2, 3\frac{1}{3}$

69. Which inequality is true if  $x = \frac{3.04}{1.48}$ ,  $y = 1.99 + 0.33$ , and  $z = (1.3)^3$ ?

[A]  $x < z < y$       [B]  $y < x < z$   
[C]  $y < z < x$       [D]  $x < y < z$

70. Which number has the greatest value?

[A]  $1\frac{2}{3}$       [B] 1.5      [C]  $\frac{\pi}{2}$       [D]  $\sqrt{2}$

71. If  $x^3 < x < \frac{1}{x}$ , then  $x$  could be equal to

[A] 1      [B] 5      [C]  $\frac{1}{5}$       [D]  $\frac{6}{5}$

72. Which expression has the *smallest* value?

[A]  $-\frac{16}{5}$       [B]  $-\pi$   
[C]  $-3.02$       [D]  $-\sqrt{10}$

73. Which numbers are arranged from smallest to largest?

[A]  $\sqrt{9.1}, \pi, 3.14, \frac{22}{7}$

[B]  $3.14, \frac{22}{7}, \pi, \sqrt{9.1}$

[C]  $\sqrt{9.1}, 3.14, \frac{22}{7}, \pi$

[D]  $\sqrt{9.1}, 3.14, \pi, \frac{22}{7}$

## MATH TOOLBOX P. 35

### NY LESSON 12

74. Which expression must be added to  $3x - 7$  to equal 0?  
[A] 0 [B]  $3x + 7$   
[C]  $-3x - 7$  [D]  $-3x + 7$
75. Which equation illustrates the distributive property for real numbers?  
[A]  $\sqrt{3} + 0 = \sqrt{3}$   
[B]  $-3(5 + 7) = (-3)(5) + (-3)(7)$   
[C]  $(1.3 \times 0.07) \times 0.63 = 1.3 \times (0.07 \times 0.63)$   
[D]  $\frac{1}{3} + \frac{1}{2} = \frac{1}{2} + \frac{1}{3}$
76. Tori computes the value of  $8 \times 95$  in her head by thinking  $8(100 - 5) = 8 \times 100 - 8 \times 5$ . Which number property is she using?  
[A] distributive [B] closure  
[C] associative [D] commutative
77. Which expression is an example of the associative property?  
[A]  $x(y + z) = xy + xz$   
[B]  $(x + y) + z = x + (y + z)$   
[C]  $x + y + z = z + y + x$  [D]  $x \cdot 1 = x$
78. Which equation illustrates the associative property of addition?  
[A]  $3 + x = 0$  [B]  $3(x + 2) = 3x + 6$   
[C]  $(3 + x) + y = 3 + (x + y)$   
[D]  $x + y = y + x$
79. What is the additive inverse of  $\frac{2}{3}$ ?  
[A]  $\frac{1}{3}$  [B]  $-\frac{2}{3}$  [C]  $\frac{3}{2}$  [D]  $-\frac{3}{2}$
80. Which property of real numbers is illustrated by the equation  $-\sqrt{3} + \sqrt{3} = 0$ ?  
[A] commutative property of addition  
[B] additive inverse [C] additive identity  
[D] associative property of addition
81. Which equation is an illustration of the additive identity property?  
[A]  $x \cdot \frac{1}{x} = 1$  [B]  $x - x = 0$   
[C]  $x + 0 = x$  [D]  $x \cdot 1 = x$
82. Which equation illustrates the multiplicative identity element?  
[A]  $x + 0 = x$  [B]  $x \cdot 1 = x$   
[C]  $x \cdot \frac{1}{x} = 1$  [D]  $x - x = 0$
83. If  $a$  and  $b$  are integers, which equation is always true?  
[A]  $a + 2b = b + 2a$  [B]  $\frac{a}{b} = \frac{b}{a}$   
[C]  $a + b = b + a$  [D]  $a - b = b - a$
84. If  $a \neq 0$  and the sum of  $x$  and  $\frac{1}{a}$  is 0, then  
[A]  $x = -\frac{1}{a}$  [B]  $x = a$   
[C]  $x = -a$  [D]  $x = 1 - a$
85. What is the multiplicative inverse of  $\frac{3}{4}$ ?  
[A]  $-\frac{3}{4}$  [B]  $-\frac{4}{3}$  [C]  $\frac{4}{3}$  [D]  $-1$

86. Which equation illustrates the distributive property?  
 [A]  $a + (b + c) = (a + b) + c$   
 [B]  $a + 0 = a$   
 [C]  $a + b = b + a$       [D]  $5(a + b) = 5a + 5b$

87. The equation  $*(\Delta + \diamond) = * \Delta + * \diamond$  is an example of the  
 [A] commutative law      [B] associative law  
 [C] distributive law      [D] transitive law

88. Which set is closed under division?  
 [A] counting numbers      [B]  $\{1\}$   
 [C] integers      [D] whole numbers

89. Ramón said that the set of integers is *not* closed for one of the basic operations (addition, subtraction, multiplication, or division). You want to show Ramón that his statement is correct. For the operation for which the set of integers is *not* closed, write an example using:  
 o a positive even integer and a zero  
 o a positive and a negative even integer  
 o two negative even integers  
 Be sure to explain why *each* of your examples illustrates that the set of integers is *not* closed for that operation.

90. The operation element @ is determined by the following table:

@	a	b	c
a	a	b	c
b	b	c	a
c	c	a	b

What is the identity element of this operation?

- [A] *b*, only      [B] *c*  
 [C] *a* and *b*      [D] *a*, only

91. The operation  $*$  for the set  $\{p, r, s, v\}$  is defined in the accompanying table. What is the inverse element of *r* under the operation  $*$ ?

*	p	r	s	v
p	s	v	p	r
r	v	p	r	s
s	p	r	s	v
v	r	s	v	p

- [A] *v*      [B] *s*      [C] *r*      [D] *p*

92. What is the identity element for  $\clubsuit$  in the accompanying table?

$\clubsuit$	r	s	t	u
r	t	r	u	s
s	r	s	t	u
t	u	t	s	r
u	s	u	r	t

- [A] *s*      [B] *t*      [C] *r*      [D] *u*

93. In the addition table for a subset of real numbers shown below, which number is the inverse of 3? Explain your answer.

$\oplus$	1	2	3	4
1	2	3	4	1
2	3	4	1	2
3	4	1	2	3
4	1	2	3	4

94. An addition table for a subset of real numbers is shown below. Which number is the identity element? Explain your answer.

+	0	1	2	3
0	0	1	2	3
1	1	2	3	4
2	2	3	4	0
3	3	4	0	1

## ALGEBRA CHAPTER 2-2

95. John left his home and walked 3 blocks to his school, as shown in the accompanying graph.

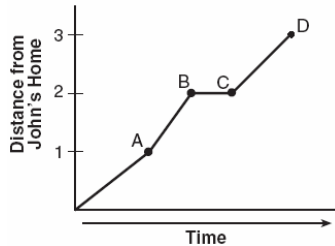

What is one possible interpretation of the section of the graph from point *B* to point *C*?

- [A] John reached the top of a hill and began walking on level ground.  
 [B] John returned home to get his mathematics homework.  
 [C] John arrived at school and stayed throughout the day.  
 [D] John waited before crossing a busy street.
96. The accompanying graph shows the amount of water left in Rover's water dish over a period of time.

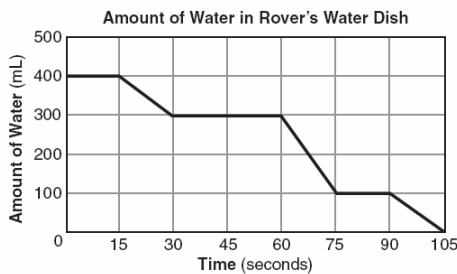

How long did Rover wait from the end of his first drink to the start of his second drink of water?

- [A] 10 sec                      [B] 60 sec  
 [C] 75 sec                      [D] 30 sec

97. The accompanying graph shows Marie's distance from home (*A*) to work (*F*) at various times during her drive.

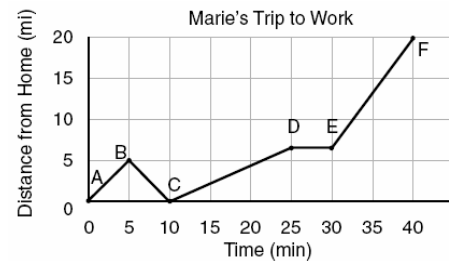

- a* Marie left her briefcase at home and had to return to get it. State which point represents when she turned back around to go home and explain how you arrived at that conclusion.  
*b* Marie also had to wait at the railroad tracks for a train to pass. How long did she wait?
98. A bug travels up a tree, from the ground, over a 30-second interval. It travels fast at first and then slows down. It stops for 10 seconds, then proceeds slowly, speeding up as it goes. Which sketch best illustrates the bug's distance (*d*) from the ground over the 30-second interval (*t*)?

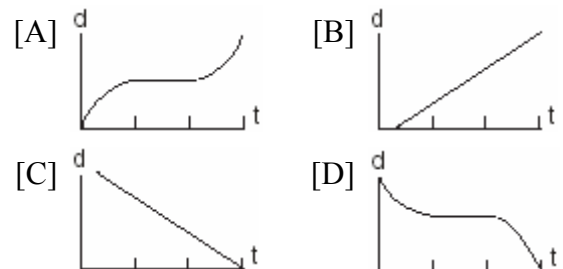

## ALGEBRA CHAPTER 2-6

99. Which linear equation represents the data in the accompanying table?

<i>c</i>	<i>d</i>
0	20.00
1	21.50
2	23.00
3	24.50

- [A]  $d = 21.50c$                       [B]  $d = 20.00c + 1.50$   
 [C]  $d = 1.50c$                       [D]  $d = 1.50c + 20.00$

100. Which equation could represent the relationship between the  $x$  and  $y$  values shown in the accompanying table?

$x$	$y$
0	2
1	3
2	6
3	11
4	18

- [A]  $y = x + 2$                       [B]  $y = x^2 + 2$   
 [C]  $y = x^2$                               [D]  $y = 2^x$
101. If  $x$  and  $y$  are defined as indicated by the accompanying table, which equation correctly represents the relationship between  $x$  and  $y$ ?

$x$	$y$
2	1
3	3
5	7
7	11

- [A]  $y = 2x + 3$                       [B]  $y = 2x + 2$   
 [C]  $y = 2x - 3$                       [D]  $y = x + 2$
102. If the temperature in Buffalo is  $23^\circ$  Fahrenheit, what is the temperature in degrees Celsius? [Use the formula  $C = \frac{5}{9}(F - 32)$ .]
- [A]  $-45$     [B]  $-5$     [C]  $45$     [D]  $5$
103. The formula  $C = \frac{5}{9}(F - 32)$  can be used to find the Celsius temperature ( $C$ ) for a given Fahrenheit temperature ( $F$ ). What Celsius temperature is equal to a Fahrenheit temperature of  $77^\circ$ ?
- [A]  $45^\circ$     [B]  $8^\circ$     [C]  $25^\circ$     [D]  $171^\circ$

104. The formula for changing Celsius ( $C$ ) temperature to Fahrenheit ( $F$ ) temperature is  $F = \frac{9}{5}C + 32$ . Calculate, to the nearest degree, the Fahrenheit temperature when the Celsius temperature is  $-8$ .
105. Connor wants to compare Celsius and Fahrenheit temperatures by drawing a conversion graph. He knows that  $-40^\circ C = -40^\circ F$  and that  $20^\circ C = 68^\circ F$ . On the accompanying grid, construct the conversion graph and, using the graph, determine the Celsius equivalent of  $25^\circ F$ .

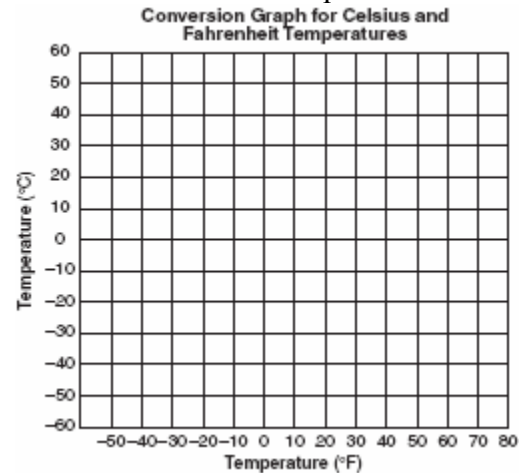

## ALGEBRA CHAPTER 2-8

106. Mary chooses an integer at random from 1 to 6. What is the probability that the integer she chooses is a prime number?
- [A]  $\frac{4}{6}$     [B]  $\frac{5}{6}$     [C]  $\frac{3}{6}$     [D]  $\frac{2}{6}$
107. A box contains six black balls and four white balls. What is the probability of selecting a black ball at random from the box?
- [A]  $\frac{1}{10}$     [B]  $\frac{6}{4}$     [C]  $\frac{6}{10}$     [D]  $\frac{4}{6}$

108. A fair coin is thrown in the air four times. If the coin lands with the head up on the first three tosses, what is the probability that the coin will land with the head up on the fourth toss?

- [A] 0      [B]  $\frac{1}{8}$       [C]  $\frac{1}{16}$       [D]  $\frac{1}{2}$

109. A fair coin is tossed three times. What is the probability that the coin will land tails up on the second toss?

- [A]  $\frac{1}{3}$       [B]  $\frac{2}{3}$       [C]  $\frac{1}{2}$       [D]  $\frac{3}{4}$

110. If the probability that it will rain on Thursday is  $\frac{5}{6}$ , what is the probability that it will *not* rain on Thursday?

- [A] 1      [B]  $\frac{5}{6}$       [C] 0      [D]  $\frac{1}{6}$

111. The party registration of the voters in Jonesville is shown in the table below.

Registered Voters in Jonesville	
Party Registration	Number of Voters Registered
Democrat	6,000
Republican	5,300
Independent	3,700

If one of the registered Jonesville voters is selected at random, what is the probability that the person selected is *not* a Democrat?

- [A] 0.400      [B] 0.333  
[C] 0.600      [D] 0.667

112. If Laquisha can enter school by any one of three doors and the school has two staircases to the second floor, in how many different ways can Laquisha reach a room on the second floor? Justify your answer by drawing a tree diagram or listing a sample space.

113. The Grimaldis have three children born in different years.

- a* Draw a tree diagram or list a sample space to show all the possible arrangements of boy and girl children in the Grimaldi family.  
*b* Using your information from part *a*, what is the probability that the Grimaldis have three boys?

## ALGEBRA CHAPTER 3-2

114. If  $2x + 5 = -25$  and  $-3m - 6 = 48$ , what is the product of  $x$  and  $m$ ?

- [A] -270      [B] 3      [C] 270      [D] -33

115. If  $-2x + 3 = 7$  and  $3x + 1 = 5 + y$ , the value of  $y$  is

- [A] 1      [B] -10      [C] 0      [D] 10

116. How many times larger than  $\frac{1}{4}x$  is  $5x$ ?

- [A]  $\frac{5}{4}$       [B] 20      [C] 9      [D]  $\frac{4}{5}$

117. At the beginning of her mathematics class, Mrs. Reno gives a warm-up problem. She says, "I am thinking of a number such that 6 less than the product of 7 and this number is 85." Which number is she thinking of?

- [A] 637      [B] 84      [C] 13      [D]  $11\frac{2}{7}$

118. Mr. Perez owns a sneaker store. He bought 350 pairs of basketball sneakers and 150 pairs of soccer sneakers from the manufacturers for \$62,500. He sold all the sneakers and made a 25% profit. If he sold the soccer sneakers for \$130 per pair, how much did he charge for one pair of basketball sneakers?



## ALGEBRA CHAPTER 3-3

119. Ashanti and Maria went to the store to buy snacks for their back-to-school party. They bought bags of chips, pretzels, and nachos. They bought three times as many bags of pretzels as bags of chips, and two fewer bags of nachos than bags of pretzels. If  $x$  represents the number of bags of chips they bought, express, in terms of  $x$ , how many bags of snacks they bought in all.
120. At a concert, \$720 was collected for hot dogs, hamburgers, and soft drinks. All three items sold for \$1.00 each. Twice as many hot dogs were sold as hamburgers. Three times as many soft drinks were sold as hamburgers. The number of soft drinks sold was  
[A] 120 [B] 240 [C] 360 [D] 480
121. Sara's telephone service costs \$21 per month plus \$0.25 for each local call, and long-distance calls are extra. Last month, Sara's bill was \$36.64, and it included \$6.14 in long-distance charges. How many local calls did she make?
122. What is the solution of the equation  $3y - 5y + 10 = 36$ ?  
[A] 2 [B] 4.5 [C] -13 [D] 13
123. The sum of the ages of the three Romano brothers is 63. If their ages can be represented as consecutive integers, what is the age of the middle brother?
124. What is the solution set of the equation  $\frac{x}{5} + \frac{x}{2} = 14$ ?  
[A] {4} [B] {10} [C] {20} [D] {49}

125. Mary and Amy had a total of 20 yards of material from which to make costumes. Mary used three times more material to make her costume than Amy used, and 2 yards of material was not used. How many yards of materials did Amy use for her costume?

## ALGEBRA CHAPTER 3-4

126. Which equation illustrates the distributive property of multiplication over addition?  
[A]  $6(3a + 4b) = 18a + 4b$   
[B]  $6(3a + 4b) = (3a + 4b)6$   
[C]  $6(3a + 4b) = 18a + 24b$   
[D]  $6(3a + 4b) = 6(4b + 3a)$
127. Solve for  $x$ :  $15x - 3(3x + 4) = 6$   
[A] 3 [B]  $-\frac{1}{2}$  [C]  $\frac{1}{3}$  [D] 1
128. What is the value of  $n$  in the equation  $0.6(n + 10) = 3.6$ ?  
[A] -0.4 [B] 5 [C] 4 [D] -4
129. Parking charges at Superior Parking Garage are \$5.00 for the first hour and \$1.50 for each additional 30 minutes. If Margo has \$12.50, what is the maximum amount of time she will be able to park her car at the garage?  
[A]  $3\frac{1}{2}$  hours [B]  $2\frac{1}{2}$  hours  
[C]  $6\frac{1}{2}$  hours [D] 6 hours

## ALGEBRA CHAPTER 3-5

130. In his will, a man leaves one-half of his money to his wife, one-half of what is then left to his older child, and one-half of what is then left to his younger child. His two cousins divide the remainder equally, each receiving \$2,000. What was the total amount of money in the man's will?
- [A] \$16,000                      [B] \$32,000  
[C] \$24,000                      [D] \$40,000
131. There are 28 students in a mathematics class. If  $\frac{1}{4}$  of the students are called to the guidance office,  $\frac{1}{3}$  of the remaining students are called to the nurse, and, finally,  $\frac{1}{2}$  of those left go to the library, how many students remain in the classroom?
132. In a town election, candidates  $A$  and  $B$  were running for mayor. There were 30,500 people eligible to vote, and  $\frac{3}{4}$  of them actually voted. Candidate  $B$  received  $\frac{1}{3}$  of the votes cast. How many people voted for candidate  $B$ ? What percent of the votes cast, to the nearest tenth of a percent, did candidate  $A$  receive?

133. After an ice storm, the following headlines were reported in the *Glacier County Times*:  
Monday: Ice Storm Devastates County - 8 out of every 10 homes lose electrical power  
Tuesday: Restoration Begins - Power restored to  $\frac{1}{2}$  of affected homes  
Wednesday: More Freezing Rain - Power lost by 20% of homes that had power on Tuesday  
Based on these headlines, what fractional portion of homes in Glacier County had electrical power on Wednesday?

## ALGEBRA CHAPTER 3-6

134. Selena and Tracey play on a softball team. Selena has 8 hits out of 20 times at bat, and Tracey has 6 hits out of 16 times at bat. Based on their past performance, what is the probability that both girls will get a hit next time at bat?
- [A]  $\frac{14}{36}$     [B]  $\frac{31}{40}$     [C]  $\frac{48}{320}$     [D] 1
135. Bob and Laquisha have volunteered to serve on the Junior Prom Committee. The names of twenty volunteers, including Bob and Laquisha, are put into a bowl. If two names are randomly drawn from the bowl without replacement, what is the probability that Bob's name will be drawn first and Laquisha's name will be drawn second?
- [A]  $\frac{1}{20} \cdot \frac{1}{20}$                       [B]  $\frac{2}{20}$   
[C]  $\frac{1}{20} \cdot \frac{1}{19}$                       [D]  $\frac{2}{20!}$

136. A student council has seven officers, of which five are girls and two are boys. If two officers are chosen at random to attend a meeting with the principal, what is the probability that the first officer chosen is a girl and the second is a boy?

[A]  $\frac{2}{7}$       [B]  $\frac{10}{42}$       [C]  $\frac{7}{13}$       [D]  $\frac{7}{14}$

137. The probability that the Cubs win their first game is  $\frac{1}{3}$ . The probability that the Cubs win their second game is  $\frac{3}{7}$ . What is the probability that the Cubs win both games?

[A]  $\frac{6}{7}$       [B]  $\frac{1}{7}$       [C]  $\frac{16}{21}$       [D]  $\frac{2}{5}$

138. There are four students, all of different heights, who are to be randomly arranged in a line. What is the probability that the tallest student will be first in line and the shortest student will be last in line?

139. Mr. Yee has 10 boys and 15 girls in his mathematics class. If he chooses two students at random to work on the blackboard, what is the probability that both students chosen are girls?

140. A bookshelf contains six mysteries and three biographies. Two books are selected at random without replacement.
- a* What is the probability that both books are mysteries?
- b* What is the probability that one book is a mystery and the other is a biography?

## ALGEBRA CHAPTER 3-7

141. Twenty-five percent of 88 is the same as what percent of 22?

[A]  $12\frac{1}{2}\%$       [B] 40%  
[C] 100%      [D] 50%

142. Ninety percent of the ninth grade students at Richbartville High School take algebra. If 180 ninth grade students take algebra, how many ninth grade students do *not* take algebra?

143. Linda paid \$48 for a jacket that was on sale for 25% of the original price. What was the original price of the jacket?

[A] \$96      [B] \$60      [C] \$72      [D] \$192

144. A painting that regularly sells for a price of \$55 is on sale for 20% off. The sales tax on the painting is 7%. Will the final total cost of the painting differ depending on whether the salesperson deducts the discount before adding the sales tax or takes the discount after computing the sum of the original price and the sales tax on \$55?

145. In bowling leagues, some players are awarded extra points called their "handicap." The "handicap" in Anthony's league is 80% of the difference between 200 and the bowler's average. Anthony's average is 145. What is Anthony's "handicap"?

146. Sue bought a picnic table on sale for 50% off the original price. The store charged her 10% tax and her final cost was \$22.00. What was the original price of the picnic table?

147. Walter is a waiter at the Towne Diner. He earns a daily wage of \$50, plus tips that are equal to 15% of the total cost of the dinners he serves. What was the total cost of the dinners he served if he earned \$170 on Tuesday?

153. In a molecule of water, there are two atoms of hydrogen and one atom of oxygen. How many atoms of hydrogen are in 28 molecules of water?

[A] 56 [B] 42 [C] 29 [D] 14

## ALGEBRA CHAPTER 3-8

148. The world population was 4.2 billion people in 1982. The population in 1999 reached 6 billion. Find the percent of change from 1982 to 1999.

154. A cake recipe calls for 1.5 cups of milk and 3 cups of flour. Seth made a mistake and used 5 cups of flour. How many cups of milk should he use to keep the proportions correct?

[A] 1.75 [B] 2 [C] 2.5 [D] 2.25

149. Rashawn bought a CD that cost \$18.99 and paid \$20.51, including sales tax. What was the rate of the sales tax?

[A] 5% [B] 2% [C] 8% [D] 3%

155. A girl can ski down a hill five times as fast as she can climb up the same hill. If she can climb up the hill and ski down in a total of 9 minutes, how many minutes does it take her to climb up the hill?

[A] 7.5 [B] 7.2 [C] 4.5 [D] 1.8

## NY LESSON 11

150. A factory packs CD cases into cartons for a music company. Each carton is designed to hold 1,152 CD cases. The Quality Control Unit in the factory expects an error of less than 5% over or under the desired packing number. What is the *least* number and the *most* number of CD cases that could be packed in a carton and still be acceptable to the Quality Control Unit?

156. A truck traveling at a constant rate of 45 miles per hour leaves Albany. One hour later a car traveling at a constant rate of 60 miles per hour also leaves Albany traveling in the same direction on the same highway. How long will it take for the car to catch up to the truck, if both vehicles continue in the same direction on the highway?

157. A truck travels 40 miles from point *A* to point *B* in exactly 1 hour. When the truck is halfway between point *A* and point *B*, a car starts from point *A* and travels at 50 miles per hour. How many miles has the car traveled when the truck reaches point *B*?

[A] 60 [B] 40 [C] 25 [D] 50

## ALGEBRA CHAPTER 4-1

151. Julio's wages vary directly as the number of hours that he works. If his wages for 5 hours are \$29.75, how much will he earn for 30 hours?

152. If the instructions for cooking a turkey state "Roast turkey at 325° for 20 minutes per pound," how many hours will it take to roast a 20-pound turkey at 325°?

158. Bob and Latoya both drove to a baseball game at a college stadium. Bob lives 70 miles from the stadium and Latoya lives 60 miles from it, as shown in the accompanying diagram. Bob drove at a rate of 50 miles per hour, and Latoya drove at a rate of 40 miles per hour. If they both left home at the same time, who got to the stadium first?

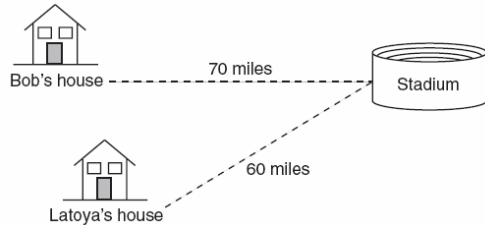

159. Two trains leave the same station at the same time and travel in opposite directions. One train travels at 80 kilometers per hour and the other at 100 kilometers per hour. In how many hours will they be 900 kilometers apart?
160. A rocket car on the Bonneville Salt Flats is traveling at a rate of 640 miles per hour. How much time would it take for the car to travel 384 miles at this rate?
- [A] 36 minutes            [B] 245 minutes  
[C] 1.7 hours            [D] 256 minutes
161. A hockey team played  $n$  games, losing four of them and winning the rest. The ratio of games won to games lost is
- [A]  $\frac{n}{4}$     [B]  $\frac{n-4}{4}$     [C]  $\frac{4}{n-4}$     [D]  $\frac{4}{n}$
162. A total of \$450 is divided into equal shares. If Kate receives four shares, Kevin receives three shares, and Anna receives the remaining two shares, how much money did Kevin receive?
- [A] \$250                    [B] \$150  
[C] \$200                    [D] \$100
163. During a recent winter, the ratio of deer to foxes was 7 to 3 in one county of New York State. If there were 210 foxes in the county, what was the number of deer in the county?
- [A] 147    [B] 90    [C] 280    [D] 490
164. Sterling silver is made of an alloy of silver and copper in the ratio of 37:3. If the mass of a sterling silver ingot is 600 grams, how much silver does it contain?
- [A] 555 g                    [B] 200 g  
[C] 450 g                    [D] 48.65 g
165. There are 357 seniors in Harris High School. The ratio of boys to girls is 7:10. How many boys are in the senior class?
- [A] 147    [B] 210    [C] 107    [D] 117
166. The profits in a business are to be shared by the three partners in the ratio of 3 to 2 to 5. The profit for the year was \$176,500. Determine the number of dollars each partner is to receive.
167. At the Phoenix Surfboard Company, \$306,000 in profits was made last year. This profit was shared by the four partners in the ratio 3:3:5:7. How much *more* money did the partner with the largest share make than one of the partners with the smallest share?
168. On a map, 1 centimeter represents 40 kilometers. How many kilometers are represented by 8 centimeters?
- [A] 5            [B] 280    [C] 48            [D] 320
169. An image of a building in a photograph is 6 centimeters wide and 11 centimeters tall. If the image is similar to the actual building and the actual building is 174 meters wide, how tall is the actual building, in meters?

170. If a girl 1.2 meters tall casts a shadow 2 meters long, how many meters tall is a tree that casts a shadow 75 meters long at the same time?
171. A 12-foot tree casts a 16-foot shadow. How many feet tall is a nearby tree that casts a 20-foot shadow at the same time?
172. On her first trip, Sari biked 24 miles in  $T$  hours. The following week Sari biked 32 miles in  $T$  hours. Determine the ratio of her average speed on her second trip to her average speed on her first trip.
- [A]  $\frac{2}{3}$  [B]  $\frac{3}{4}$  [C]  $\frac{3}{2}$  [D]  $\frac{4}{3}$
173. On a trip, a student drove 40 miles per hour for 2 hours and then drove 30 miles per hour for 3 hours. What is the student's average rate of speed, in miles per hour, for the whole trip?
- [A] 34 [B] 36 [C] 35 [D] 37
174. If Jamar can run  $\frac{3}{5}$  of a mile in 2 minutes 30 seconds, what is his rate in miles per minute?
- [A]  $\frac{4}{5}$  [B]  $\frac{6}{25}$  [C]  $4\frac{1}{6}$  [D]  $3\frac{1}{10}$
175. A bicyclist leaves Bay Shore traveling at an average speed of 12 miles per hour. Three hours later, a car leaves Bay Shore, on the same route, traveling at an average speed of 30 miles per hour. How many hours after the car leaves Bay Shore will the car catch up to the cyclist?
- [A] 5 [B] 2 [C] 4 [D] 8
177. What is the value of  $x$  in the equation  $\frac{3}{4}x + 2 = \frac{5}{4}x - 6$ ?
- [A] -16 [B] 16 [C] 4 [D] -4
178. If  $2(x + 3) = x + 10$ , then  $x$  equals
- [A] 5 [B] 4 [C] 7 [D] 14
179. Solve for  $m$ :  $0.6m + 3 = 2m + 0.2$
180. Solve for  $x$ :  $2(x - 3) = 1.2 - x$
181. If  $x + y = 9x + y$ , then  $x$  is equal to
- [A] 8 [B]  $y$  [C]  $\frac{1}{5}y$  [D] 0
182. If  $9x + 2a = 3a - 4x$ , then  $x$  equals
- [A]  $a$  [B]  $-a$  [C]  $\frac{5a}{12}$  [D]  $\frac{a}{13}$
183. If  $7x + 2a = 3x + 5a$ , then  $x$  is equivalent to
- [A]  $\frac{7a}{10}$  [B]  $\frac{3a}{4}$  [C]  $\frac{3a}{10}$  [D]  $\frac{7a}{4}$
184. The number of people on the school board is represented by  $x$ . Two subcommittees with an equal number of members are formed, one with  $\frac{2}{3}x - 5$  members and the other with  $\frac{x}{4}$  members. How many people are on the school board?
- [A] 4 [B] 12 [C] 8 [D] 20
185. A boy got 50% of the questions on a test correct. If he had 10 questions correct out of the first 12, and  $\frac{1}{4}$  of the remaining questions correct, how many questions were on the test?
- [A] 26 [B] 16 [C] 24 [D] 28

## ALGEBRA CHAPTER 4-2

176. If  $3(x - 2) = 2x + 6$ , the value of  $x$  is
- [A] 20 [B] 0 [C] 5 [D] 12

186. If one-half of a number is 8 less than two-thirds of the number, what is the number?  
[A] 24 [B] 32 [C] 54 [D] 48

### ALGEBRA CHAPTER 4-4

187. The equation  $P = 2L + 2W$  is equivalent to

[A]  $L = \frac{P-2W}{2}$  [B]  $2L = \frac{P}{2W}$   
[C]  $L = P - W$  [D]  $L = \frac{P+2W}{2}$

188. Shoe sizes and foot length are related by the formula  $S = 3F - 24$ , where  $S$  represents the shoe size and  $F$  represents the length of the foot, in inches.

- a Solve the formula for  $F$ .  
b To the *nearest tenth of an inch*, how long is the foot of a person who wears a size  $10\frac{1}{2}$  shoe?

189. If  $2m + 2p = 16$ ,  $p$  equals

[A]  $9m$  [B]  $16 - m$   
[C]  $16 + 2m$  [D]  $8 - m$

190. If  $bx - 2 = K$ , then  $x$  equals

[A]  $\frac{K}{b} + 2$  [B]  $\frac{K-2}{b}$   
[C]  $\frac{2-K}{b}$  [D]  $\frac{K+2}{b}$

191. If  $x = 2a - b^2$ , then  $a$  equals

[A]  $\frac{x+b^2}{2}$  [B]  $\frac{x-b^2}{2}$   
[C]  $x+b^2$  [D]  $\frac{b^2-x}{2}$

### ALGEBRA CHAPTER 4-7

192. The inequality  $\frac{1}{2}x + 3 < 2x - 6$  is equivalent to

[A]  $x < 6$  [B]  $x > 6$   
[C]  $x < -\frac{5}{6}$  [D]  $x > -\frac{5}{6}$

### ALGEBRA CHAPTER 4-8

193. Which inequality is represented in the graph below?



[A]  $-4 \leq x \leq 2$  [B]  $-4 < x \leq 2$   
[C]  $-4 \leq x < 2$  [D]  $-4 < x < 2$

194. Which inequality is represented in the accompanying graph?



[A]  $-3 \leq x \leq 4$  [B]  $-3 < x < 4$   
[C]  $-3 < x \leq 4$  [D]  $-3 \leq x < 4$

195. Which graph represents the solution set for  $2x - 4 \leq 8$  and  $x + 5 \geq 7$ ?

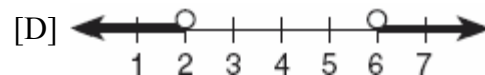
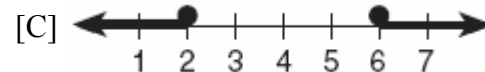
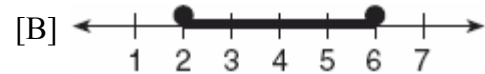
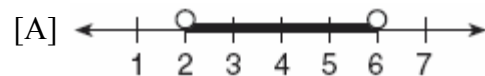

196. If  $a + b$  is less than  $c + d$ , and  $d + e$  is less than  $a + b$ , then  $e$  is

- [A] less than  $d$             [B] equal to  $c$   
[C] less than  $c$             [D] greater than  $d$

197. On June 17, the temperature in New York City ranged from  $90^\circ$  to  $99^\circ$ , while the temperature in Niagara Falls ranged from  $60^\circ$  to  $69^\circ$ . The difference in the temperatures in these two cities must be between

- [A]  $20^\circ$  and  $30^\circ$             [B]  $30^\circ$  and  $40^\circ$   
[C]  $20^\circ$  and  $40^\circ$             [D]  $25^\circ$  and  $35^\circ$

198. The manufacturer of Ron's car recommends that the tire pressure be at least 26 pounds per square inch and less than 35 pounds per square inch. On the accompanying number line, graph the inequality that represents the recommended tire pressure.

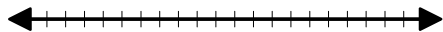

## MATH TOOLBOX P. 201

199. The accompanying diagram shows the results of a survey asking which sports the members of the Key Club watch on television.

**Sports Watched on Television**

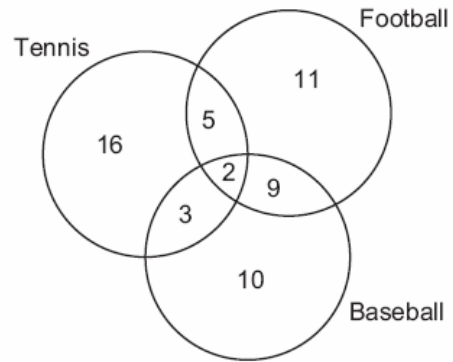

Which statement or statements are true?

- I The most watched sport is tennis.
- II The least watched sport is baseball.
- III More Key Club members watch tennis than football.

- [A] II and III, only    [B] II, only  
[C] I and II, only    [D] I, only

200. The accompanying Venn diagram shows the number of students who take various courses. All students in circle A take mathematics. All in circle B take science. All in circle C take technology. What percentage of the students take mathematics or technology?

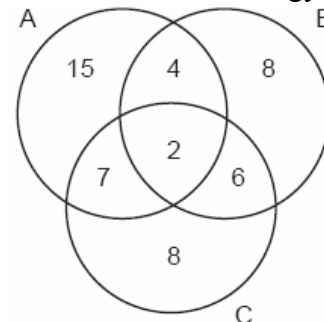



201. Seventy-eight students participate in one or more of three sports: baseball, tennis, and golf. Four students participate in all three sports; five play both baseball and golf, only; two play both tennis and golf, only; and three play both baseball and tennis, only. If seven students play only tennis and one plays only golf, what is the total number of students who play only baseball?  
[A] 12 [B] 60 [C] 44 [D] 56
202. A school district offers hockey and basketball. The result of a survey of 300 students showed:  
120 students play hockey, only  
90 students play basketball, only  
30 students do not participate in either sport  
Of those surveyed, how many students play both hockey and basketball?
203. In a class of 450 students, 300 are taking a mathematics course and 260 are taking a science course. If 140 of these students are taking both courses, how many students are not taking either of these courses?  
[A] 40 [B] 140 [C] 30 [D] 110
204. In a class of 50 students, 18 take music, 26 take art, and 2 take both art and music. How many students in the class are not enrolled in either music or art?  
[A] 16 [B] 24 [C] 6 [D] 8
205. The senior class at South High School consists of 250 students. Of these students, 130 have brown hair, 160 have brown eyes, and 90 have both brown hair and brown eyes. How many members of the senior class have *neither* brown hair *nor* brown eyes?
206. In a telephone survey of 100 households, 32 households purchased Brand A cereal and 45 purchased Brand B cereal. If 10 households purchased both items, how many of the households surveyed did *not* purchase either Brand A or Brand B cereal?
207. A car dealer has 22 vehicles on his lot. If 8 of the vehicles are vans and 6 of the vehicles are red, and 10 vehicles are neither vans nor red, how many red vans does he have on his lot?
208. In Ms. Wright's English class, 16 students are in band, 7 students play sports, 3 students participate in both activities, and 9 students are not in band and do not play sports. How many students are in Ms. Wright's English class?  
[A] 26 [B] 10 [C] 29 [D] 7
209. In a survey of 400 teenage shoppers at a large mall, 240 said they shopped at Abernathy's, 210 said they shopped at Bongo Republic, and 90 said they shopped at both stores. How many of the teenage shoppers surveyed did not shop at either store?
210. There are 30 students on a school bus. Of these students, 24 either play in the school band or sing in the chorus. Six of the students play in the school band but do not sing in the chorus. Fourteen of the students sing in the chorus and also play in the school band. How many students on the school bus sing in the chorus but do not play in the band?

## ALGEBRA CHAPTER 4-9

211. In the set of positive integers, what is the solution set of the inequality  $2x - 3 < 5$ ?  
[A]  $\{0, 1, 2, 3\}$  [B]  $\{1, 2, 3, 4\}$   
[C]  $\{0, 1, 2, 3, 4\}$  [D]  $\{1, 2, 3\}$
212. Which number is in the solution set of the inequality  $5x + 3 > 38$ ?  
[A] 6 [B] 8 [C] 5 [D] 7
213. Find all negative odd integers that satisfy the following inequality:  
 $-3x + 1 \leq 17$

214. There are 461 students and 20 teachers taking buses on a trip to a museum. Each bus can seat a maximum of 52. What is the *least* number of buses needed for the trip?

- [A] 8 [B] 9 [C] 11 [D] 10

215. In a hockey league, 87 players play on seven different teams. Each team has at least 12 players. What is the largest possible number of players on any one team?

- [A] 15 [B] 14 [C] 21 [D] 13

216. A doughnut shop charges \$0.70 for each doughnut and \$0.30 for a carryout box. Shirley has \$5.00 to spend. At most, how many doughnuts can she buy if she also wants them in one carryout box?

217. A swimmer plans to swim at least 100 laps during a 6-day period. During this period, the swimmer will increase the number of laps completed each day by one lap. What is the *least* number of laps the swimmer must complete on the first day?

219. If the value of dependent variable  $y$  increases as the value of independent variable  $x$  increases, the graph of this relationship could be a

- [A] line with a negative slope  
[B] vertical line [C] horizontal line  
[D] line with a positive slope

220. What is the slope of line  $\ell$  in the accompanying diagram?

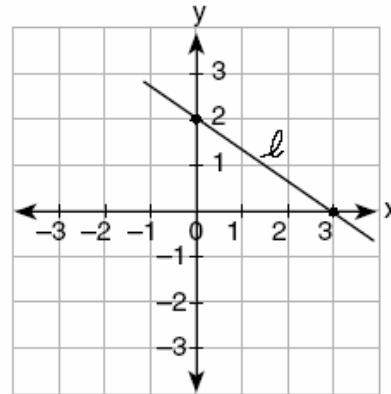

- [A]  $-\frac{3}{2}$  [B]  $\frac{2}{3}$  [C]  $-\frac{2}{3}$  [D]  $\frac{3}{2}$

221. What is the slope of line  $\ell$  shown in the accompanying diagram?

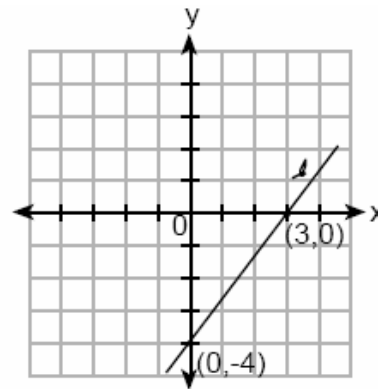

- [A]  $\frac{4}{3}$  [B]  $\frac{3}{4}$  [C]  $-\frac{4}{3}$  [D]  $-\frac{3}{4}$

## ALGEBRA CHAPTER 5-1

218. Which graph represents the equation  $x = 2$ ?

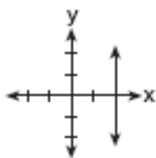
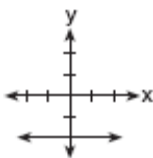
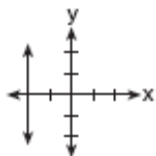
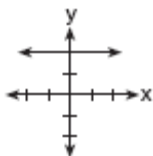
- [A]  [B]   
[C]  [D] 

222. The accompanying figure shows the graph of the equation  $x = 5$ .

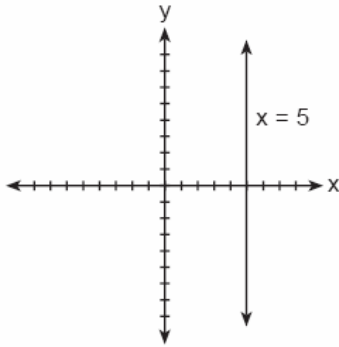

What is the slope of the line  $x = 5$ ?

- [A] -5    [B] 5    [C] undefined    [D] 0
223. A straight line with slope 5 contains the points  $(1,2)$  and  $(3,K)$ . Find the value of  $K$ .  
[The use of the accompanying grid is optional.]

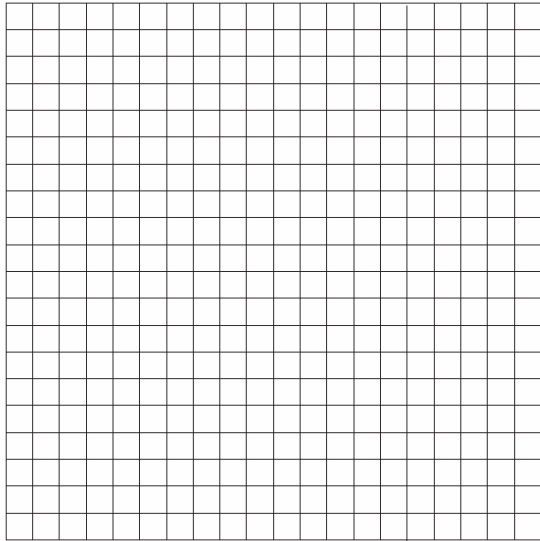

## ALGEBRA CHAPTER 5-2

224. During a 45-minute lunch period, Albert ( $A$ ) went running and Bill ( $B$ ) walked for exercise. Their times and distances are shown in the accompanying graph. How much faster was Albert running than Bill was walking, in miles per hour?

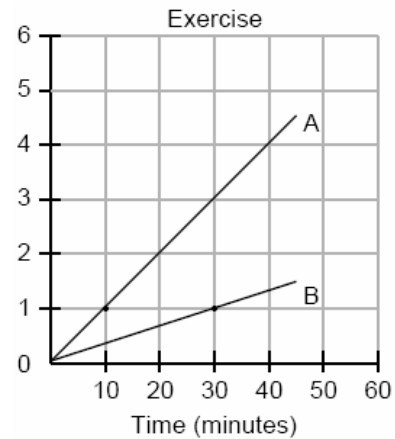

## ALGEBRA CHAPTER 5-3

225. Which table does *not* show an example of direct variation?

[A]

$x$	$y$
2	24
4	12
6	8
8	6

[B]

$x$	$y$
1	$\frac{1}{2}$
2	1
3	$\frac{3}{2}$
4	2

[C]

$x$	$y$
-4	-20
-3	-15
-2	-10
-1	-5

[D]

$x$	$y$
1	4
2	8
3	12
4	16

## ALGEBRA CHAPTER 5-4

226. What is the slope of the line whose equation is  $2y = 5x + 4$ ?

- [A]  $\frac{5}{2}$     [B] 2    [C] 5    [D]  $\frac{2}{5}$

227. An equation of the line that has a slope of 3 and a  $y$ -intercept of -2 is

[A]  $x = 3y - 2$                       [B]  $y = -2x + 3$

[C]  $y = 3x - 2$                       [D]  $y = -x$

228. If point  $(-1,0)$  is on the line whose equation is  $y = 2x + b$ , what is the value of  $b$ ?

- [A] 3            [B] 0            [C] 2            [D] 1

## ALGEBRA CHAPTER 5-5

229. Write the equation for the line shown in the accompanying graph. Explain your answer.

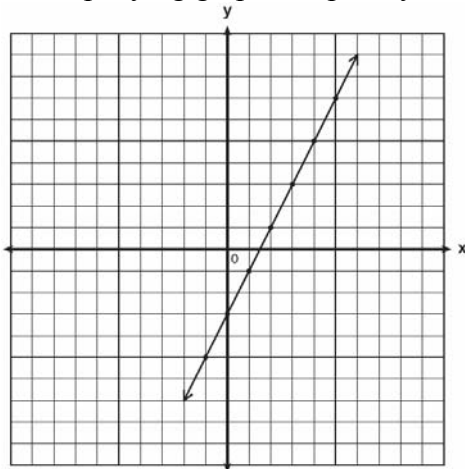

230. The accompanying graph represents the yearly cost of playing 0 to 5 games of golf at the Shadybrook Golf Course. What is the total cost of joining the club and playing 10 games during the year?

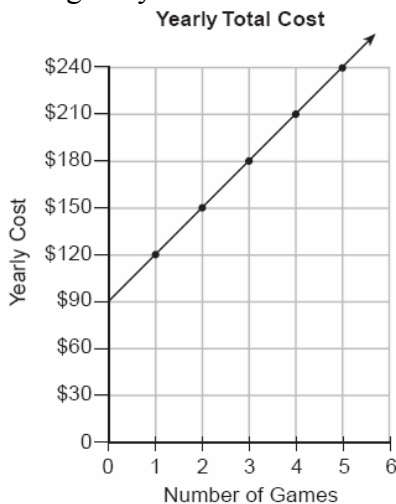

231. Line  $\ell$  contains the points  $(0,4)$  and  $(2,0)$ . Show that the point  $(-25,81)$  does or does not lie on line  $\ell$ .

## ALGEBRA CHAPTER 5-6

232. The 1999 win-loss statistics for the American League East baseball teams on a particular date is shown in the accompanying chart.

	W	L
New York	52	34
Boston	49	39
Toronto	47	43
Tampa Bay	39	49
Baltimore	36	51

Find the mean for the number of wins,  $\bar{W}$ , and the mean for the number of losses,  $\bar{L}$ , and determine if the point  $(\bar{W}, \bar{L})$  is a point on the line of best fit. Justify your answer.

233. A real estate agent plans to compare the price of a cottage,  $y$ , in a town on the seashore to the number of blocks,  $x$ , the cottage is from the beach. The accompanying table shows a random sample of sales and location data. Write a linear regression equation that relates the price of a cottage to its distance from the beach.

Use the equation to predict the price of a cottage, to the *nearest dollar*, located three blocks from the beach.

Number of Blocks from the Beach ( $x$ )	Price of a Cottage ( $y$ )
5	\$132,000
0	\$310,000
4	\$204,000
2	\$238,000
1	\$275,000
7	\$60,800

234. The accompanying table illustrates the number of movie theaters showing a popular film and the film's weekly gross earnings, in millions of dollars.

Number of Theaters ( $x$ )	443	455	493	530	569	657	723	1,064
Gross Earnings ( $y$ ) (millions of dollars)	2.57	2.65	3.73	4.05	4.76	4.76	5.15	9.35

Write the linear regression equation for this set of data, rounding values to *five decimal places*.

Using this linear regression equation, find the approximate gross earnings, in millions of dollars, generated by 610 theaters. Round your answer to *two decimal places*.

Find the minimum number of theaters that would generate at least 7.65 million dollars in gross earnings in one week.

235. The availability of leaded gasoline in New York State is decreasing, as shown in the accompanying table.

Year	1984	1988	1992	1996	2000
Gallons Available (in thousands)	150	124	104	76	50

Determine a linear relationship for  $x$  (years) versus  $y$  (gallons available), based on the data given. The data should be entered using the year and gallons available (in thousands), such as (1984,150).

If this relationship continues, determine the number of gallons of leaded gasoline available in New York State in the year 2005. If this relationship continues, during what year will leaded gasoline first become unavailable in New York State?

236. In a mathematics class of ten students, the teacher wanted to determine how a homework grade influenced a student's performance on the subsequent test. The homework grade and subsequent test grade for each student are given in the accompanying table.

Homework Grade ( $x$ )	Test Grade ( $y$ )
94	98
95	94
92	95
87	89
82	85
80	78
75	73
65	67
50	45
20	40

a Give the equation of the linear regression line for this set of data.

b A new student comes to the class and earns a homework grade of 78. Based on the equation in part *a*, what grade would the teacher predict the student would receive on the subsequent test, to the *nearest integer*?

237. The table below shows the results of an experiment that relates the height at which a ball is dropped,  $x$ , to the height of its first bounce,  $y$ .

Drop Height ( $x$ ) (cm)	Bounce Height ( $y$ ) (cm)
100	26
90	23
80	21
70	18
60	16

Find  $\bar{x}$ , the mean of the drop heights.  
 Find  $\bar{y}$ , the mean of the bounce heights.  
 Find the linear regression equation that best fits the data.  
 Show that  $(\bar{x}, \bar{y})$  is a point on the line of regression. [The use of the grid is optional.]

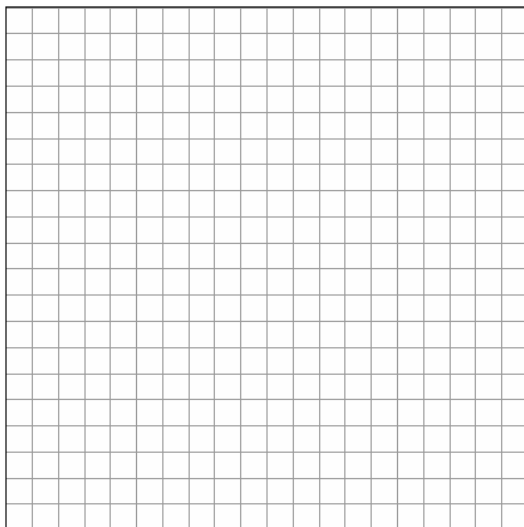

238. Two different tests were designed to measure understanding of a topic. The two tests were given to ten students with the following results:

Test $x$	75	78	88	92	95	67	58	72	74	81
Test $y$	81	73	85	88	89	73	66	75	70	78

Construct a scatter plot for these scores, and then write an equation for the line of best fit (round slope and intercept to the *nearest hundredth*).

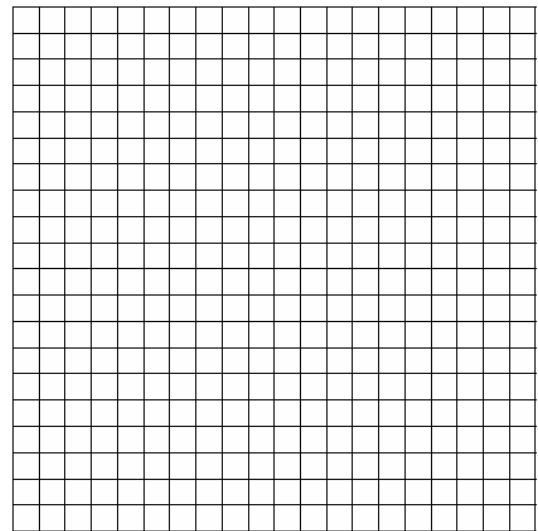

Find the correlation coefficient.  
 Predict the score, to the *nearest integer*, on test  $y$  for a student who scored 87 on test  $x$ .

## ALGEBRA CHAPTER 5-7

239. What is the slope of the line whose equation is  $3x - 4y - 16 = 0$ ?
- [A] 3      [B] -4      [C]  $\frac{4}{3}$       [D]  $\frac{3}{4}$
240. What is the slope of the linear equation  $5y - 10x = -15$ ?
- [A] 10      [B] -10      [C] 2      [D] -15

241. The line  $3x - 2y = 12$  has
- [A] a slope of  $\frac{3}{2}$  and a  $y$ -intercept of -6
  - [B] a slope of -3 and a  $y$ -intercept of -6
  - [C] a slope of  $-\frac{3}{2}$  and a  $y$ -intercept of 6
  - [D] a slope of 3 and a  $y$ -intercept of -2

## ALGEBRA CHAPTER 5-8

242. Which equation represents a line parallel to the line  $y = 2x - 5$ ?
- [A]  $y = 5x - 2$
  - [B]  $y = -2x - 5$
  - [C]  $y = -\frac{1}{2}x - 5$
  - [D]  $y = 2x + 5$
243. Which equation represents a line that is parallel to the line whose equation is  $2x + 3y = 12$ ?
- [A]  $4x - 6y = 2$
  - [B]  $6y + 4x = 2$
  - [C]  $6y - 4x = 2$
  - [D]  $6x + 4y = -2$
244. Which equation represents a line that is perpendicular to the line whose equation is  $-2y = 3x + 7$ ?
- [A]  $y = \frac{3}{2}x - 3$
  - [B]  $2y = 3x - 3$
  - [C]  $y = x + 7$
  - [D]  $y = \frac{2}{3}x - 3$
245. Shanaya graphed the line represented by the equation  $y = x - 6$ .  
Write an equation for a line that is parallel to the given line.  
Write an equation for a line that is perpendicular to the given line.  
Write an equation for a line that is identical to the given line but has different coefficients.

246. Line  $P$  and line  $C$  lie on a coordinate plane and have equal slopes. Neither line crosses the second or third quadrant. Lines  $P$  and  $C$  must
- [A] be horizontal
  - [B] be vertical
  - [C] form an angle of  $45^\circ$
  - [D] be perpendicular
247. Which properties best describe the coordinate graph of two distinct parallel lines?
- [A] different slopes and different intercepts
  - [B] same slopes and different intercepts
  - [C] same slopes and same intercepts
  - [D] different slopes and same intercepts
248. If two lines are parallel and the slope of one of the lines is  $m$ , what is the product of their slopes?
- [A] 0
  - [B]  $2m$
  - [C]  $m^2$
  - [D] 1

## ALGEBRA CHAPTER 6-3

249. Which ordered pair is the solution of the following system of equations?
- $$\begin{aligned} 3x + 2y &= 4 \\ -2x + 2y &= 24 \end{aligned}$$
- [A] (2,-1)
  - [B] (-4,8)
  - [C] (2,-5)
  - [D] (-4,-8)
250. What point is the intersection of the graphs of the lines  $2x - y = 3$  and  $x + y = 3$ ?
- [A] (3, 0)
  - [B] (3, 3)
  - [C] (2, 1)
  - [D] (1, 2)
251. What is the value of  $y$  in the following system of equations?
- $$\begin{aligned} 2x + 3y &= 6 \\ 2x + y &= -2 \end{aligned}$$
- [A] 1
  - [B] 4
  - [C] -3
  - [D] 2

252. When solved graphically, which system of equations will have exactly one point of intersection?

[A]  $y = \frac{3}{5}x + 12$       [B]  $y = -x - 20$   
 $y = 0.6x - 19$        $y = x + 17$

[C]  $y = 0.5x + 30$       [D]  $y = -x + 15$   
 $y = 0.5x - 30$        $y = -x + 25$

## ALGEBRA CHAPTER 6-4

253. Tanisha and Rachel had lunch at the mall. Tanisha ordered three slices of pizza and two colas. Rachel ordered two slices of pizza and three colas. Tanisha's bill was \$6.00, and Rachel's bill was \$5.25. What was the price of one slice of pizza? What was the price of one cola?

254. When Tony received his weekly allowance, he decided to purchase candy bars for all his friends. Tony bought three Milk Chocolate bars and four Creamy Nougat bars, which cost a total of \$4.25 without tax. Then he realized this candy would not be enough for all his friends, so he returned to the store and bought an additional six Milk Chocolate bars and four Creamy Nougat bars, which cost a total of \$6.50 without tax. How much did *each* type of candy bar cost?

255. Alexandra purchases two doughnuts and three cookies at a doughnut shop and is charged \$3.30. Briana purchases five doughnuts and two cookies at the same shop for \$4.95. All the doughnuts have the same price and all the cookies have the same price. Find the cost of one doughnut and find the cost of one cookie.

256. Ramón rented a sprayer and a generator. On his first job, he used each piece of equipment for 6 hours at a total cost of \$90. On his second job, he used the sprayer for 4 hours and the generator for 8 hours at a total cost of \$100. What was the hourly cost of *each* piece of equipment?

257. Three times as many robins as cardinals visited a bird feeder. If a total of 20 robins and cardinals visited the feeder, how many were robins?

[A] 5      [B] 10      [C] 15      [D] 20

258. A group of 148 people is spending five days at a summer camp. The cook ordered 12 pounds of food for each adult and 9 pounds of food for each child. A total of 1,410 pounds of food was ordered.

*a* Write an equation or a system of equations that describes the above situation and define your variables.

*b* Using your work from part *a*, find:

(1) the total number of adults in the group

(2) the total number of children in the group

259. Seth has one less than twice the number of compact discs (CDs) that Jason has. Raoul has 53 more CDs than Jason has. If Seth gives Jason 25 CDs, Seth and Jason will have the same number of CDs. How many CDs did *each* of the three boys have to begin with?

260. Arielle has a collection of grasshoppers and crickets. She has 561 insects in all. The number of grasshoppers is twice the number of crickets. Find the number of *each* type of insect that she has.

261. Ben had twice as many nickels as dimes. Altogether, Ben had \$4.20. How many nickels *and* how many dimes did Ben have?



262. Using only 32-cent and 20-cent stamps, Charlie put \$3.36 postage on a package he sent to his sister. He used twice as many 32-cent stamps as 20-cent stamps. Determine how many of *each* type of stamp he used.
263. The owner of a movie theater was counting the money from 1 day's ticket sales. He knew that a total of 150 tickets were sold. Adult tickets cost \$7.50 each and children's tickets cost \$4.75 each. If the total receipts for the day were \$891.25, how many of *each* kind of ticket were sold?
264. There were 100 more balcony tickets than main-floor tickets sold for a concert. The balcony tickets sold for \$4 and the main-floor tickets sold for \$12. The total amount of sales for both types of tickets was \$3,056.  
*a* Write an equation or a system of equations that describes the given situation. Define the variables.  
*b* Find the number of balcony tickets that were sold.
265. The ninth graders at a high school are raising money by selling T-shirts and baseball caps. The number of T-shirts sold was three times the number of caps. The profit they received for each T-shirt sold was \$5.00, and the profit on each cap was \$2.50. If the students made a total profit of \$210, how many T-shirts *and* how many caps were sold?
266. The tickets for a dance recital cost \$5.00 for adults and \$2.00 for children. If the total number of tickets sold was 295 and the total amount collected was \$1,220, how many adult tickets were sold? [Only an algebraic solution can receive full credit.]
267. A ribbon 56 centimeters long is cut into two pieces. One of the pieces is three times longer than the other. Find the lengths, in centimeters, of both pieces of ribbon.
268. The ratio of Tariq's telephone bill to Pria's telephone bill was 7:5. Tariq's bill was \$14 more than Pria's bill. What was Tariq's bill?  
[A] \$49 [B] \$21 [C] \$28 [D] \$35
269. Two numbers are in the ratio 2:5. If 6 is subtracted from their sum, the result is 50. What is the larger number?  
[A] 35 [B] 45 [C] 40 [D] 55
270. Jamie is 5 years older than her sister Amy. If the sum of their ages is 19, how old is Jamie?  
[A] 5 [B] 12 [C] 14 [D] 7
271. A total of 600 tickets were sold for a concert. Twice as many tickets were sold in advance than were sold at the door. If the tickets sold in advance cost \$25 each and the tickets sold at the door cost \$32 each, how much money was collected for the concert?
272. At the local video rental store, José rents two movies and three games for a total of \$15.50. At the same time, Meg rents three movies and one game for a total of \$12.05. How much money is needed to rent a combination of one game and one movie?
273. The cost of a long-distance telephone call is determined by a flat fee for the first 5 minutes and a fixed amount for each additional minute. If a 15-minute telephone call costs \$3.25 and a 23-minute call costs \$5.17, find the cost of a 30-minute call.

274. Two health clubs offer different membership plans. The graph below represents the total cost of belonging to Club *A* and Club *B* for one year.

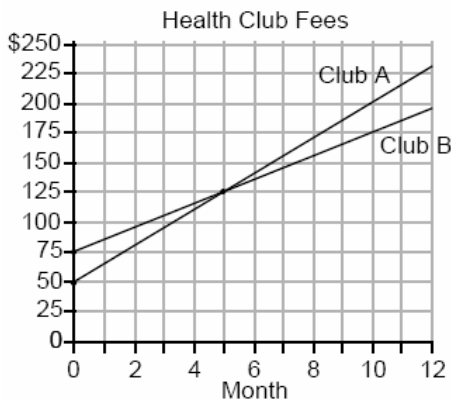

- a* If the yearly cost includes a membership fee plus a monthly charge, what is the membership fee for Club *A*?
- b* (1) What is the number of the month when the total cost is the same for both clubs?
- (2) What is the total cost for Club *A* when both plans are the same?
- c* What is the monthly charge for Club *B*?

275. At Ron's Rental, a person can rent a big-screen television for \$10 a month plus a one-time "wear-and-tear" fee of \$100. At Josie's Rental, the charge is \$20 a month and an additional charge of \$20 for delivery with no "wear-and-tear" fee.

- a* If *c* equals the cost, write one equation representing the cost of the rental for *m* months at Ron's Rental and one equation representing the cost of the rental for *m* months at Josie's Rental.
- b* On the accompanying grid, graph and label each equation.
- c* From your graph, determine in which month Josie's cost will equal Ron's cost.

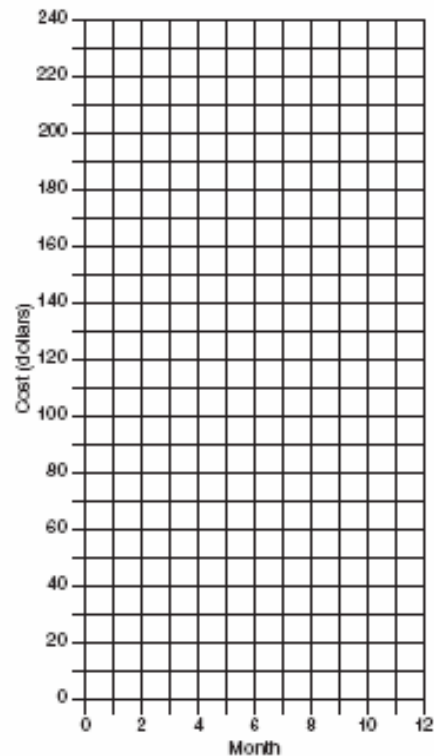

276. The senior class is sponsoring a dance. The cost of a student disk jockey is \$40, and tickets sell for \$2 each. Write a linear equation and, on the accompanying grid, graph the equation to represent the relationship between the number of tickets sold and the profit from the dance. Then find how many tickets must be sold to break even.

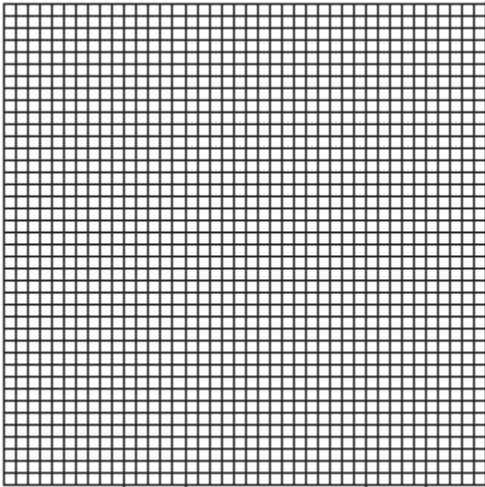

277. Currently, Tyrone has \$60 and his sister has \$135. Both get an allowance of \$5 each week. Tyrone decides to save his entire allowance, but his sister spends all of hers each week plus an additional \$10 each week. After how many weeks will they each have the same amount of money?  
[The use of the grid is optional.]

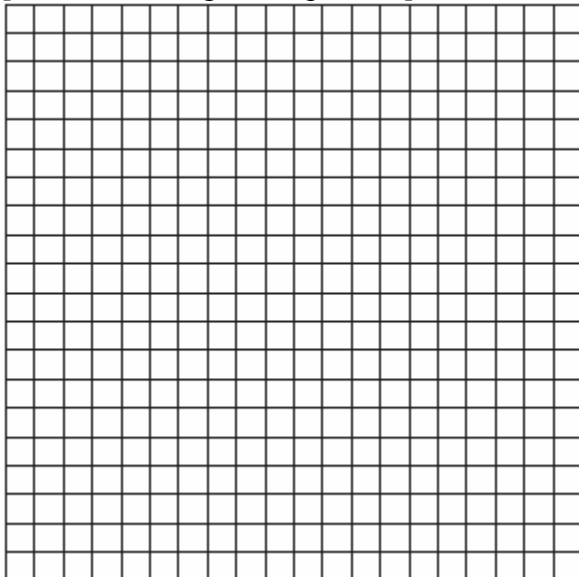

278. Juan has a cellular phone that costs \$12.95 per month plus 25¢ per minute for each call. Tiffany has a cellular phone that costs \$14.95 per month plus 15¢ per minute for each call. For what number of minutes do the two plans cost the same?
279. A hotel charges \$20 for the use of its dining room and \$2.50 a plate for each dinner. An association gives a dinner and charges \$3 a plate but invites four nonpaying guests. If each person has one plate, how many paying persons must attend for the association to collect the exact amount needed to pay the hotel?  
[A] 60    [B] 40    [C] 44    [D] 20
280. The Excel Cable Company has a monthly fee of \$32.00 and an additional charge of \$8.00 for each premium channel. The Best Cable Company has a monthly fee of \$26.00 and additional charge of \$10.00 for each premium channel. The Horton family is deciding which of these two cable companies to subscribe to.  
a For what number of premium channels will the total monthly subscription fee for the Excel and Best Cable companies be the same?  
b The Horton family decides to subscribe to 2 premium channels for a period of one year.  
(1) Which cable company should they subscribe to in order to spend less money?  
(2) How much money will the Hortons save in one year by using the less expensive company?
281. A cellular telephone company has two plans. Plan *A* charges \$11 a month and \$0.21 per minute. Plan *B* charges \$20 a month and \$0.10 per minute. After how much time, to the *nearest minute*, will the cost of plan *A* be equal to the cost of plan *B*?  
[A] 81 hr 8 min    [B] 1 hr 22 m  
[C] 1 hr 36 min    [D] 81 hr 48 min

282. Island Rent-a-Car charges a car rental fee of \$40 plus \$5 per hour or fraction of an hour. Wayne's Wheels charges a car rental fee of \$25 plus \$7.50 per hour or fraction of an hour. Under what conditions does it cost *less* to rent from Island Rent-a-Car? [The use of the accompanying grid is optional.]

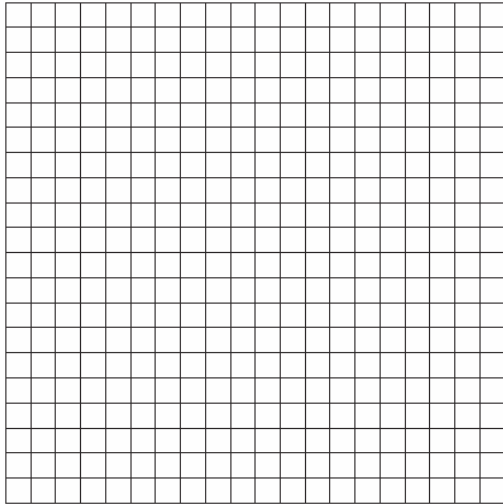

## ALGEBRA CHAPTER 6-6

285. Which point is in the solution set of the system of inequalities shown in the accompanying graph?

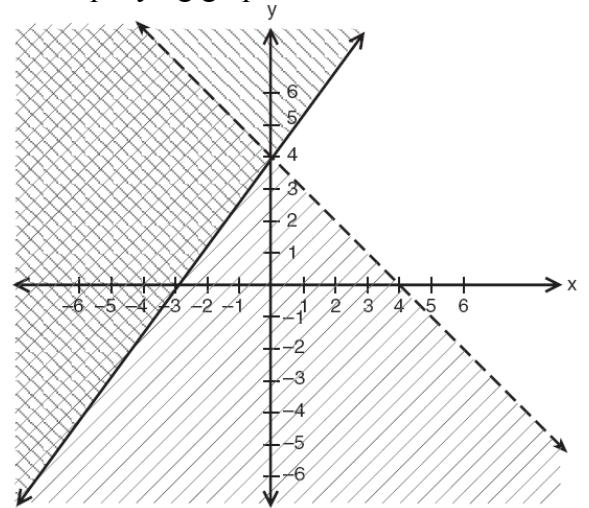

- [A] (4, -1)                      [B] (-4, 1)  
[C] (2, 4)                        [D] (0, 4)

## ALGEBRA CHAPTER 6-5

283. In the graph of  $y \leq -x$ , which quadrant is completely shaded?  
[A] I      [B] III      [C] IV      [D] II
284. Which ordered pair is not in the solution set of  $y > 2x + 1$ ?  
[A] (1,6)    [B] (2,5)    [C] (3,8)    [D] (1,4)

## ALGEBRA CHAPTER 6-7

286. A company manufactures bicycles and skateboards. The company's daily production of bicycles cannot exceed 10, and its daily production of skateboards must be less than or equal to 12. The combined number of bicycles and skateboards cannot be more than 16. If  $x$  is the number of bicycles and  $y$  is the number of skateboards, graph on the accompanying set of axes the region that contains the number of bicycles and skateboards the company can manufacture daily.

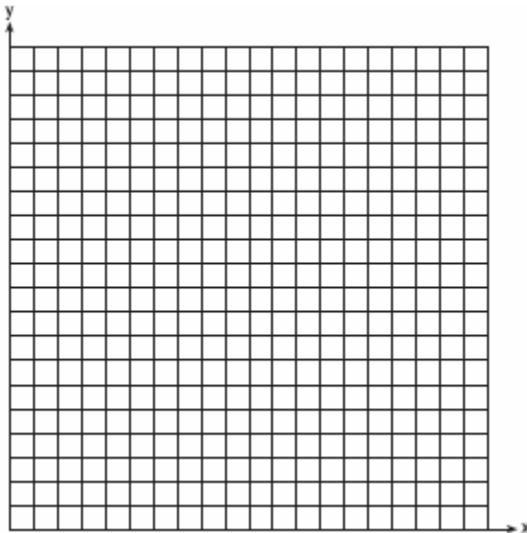

288. A rocket is launched from the ground and follows a parabolic path represented by the equation  $y = -x^2 + 10x$ . At the same time, a flare is launched from a height of 10 feet and follows a straight path represented by the equation  $y = -x + 10$ . Using the accompanying set of axes, graph the equations that represent the paths of the rocket and the flare, and find the coordinates of the point or points where the paths intersect.

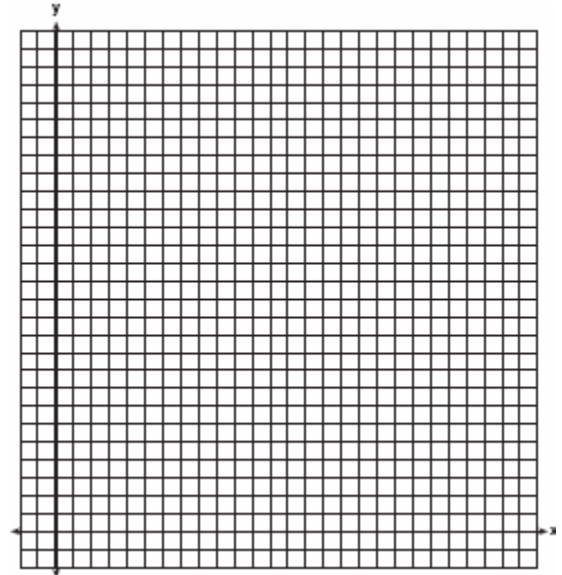

## ALGEBRA CHAPTER 6-8

287. The graphs of the equations  $y = x^2 + 4x - 1$  and  $y + 3 = x$  are drawn on the same set of axes. At which point do the graphs intersect?

- [A] (-2, 1)                      [B] (-2, -5)  
[C] (1, 4)                        [D] (1, -2)

289. Solve the following system of equations:

$$y = x^2 + 4x + 1$$

$$y = 5x + 3$$

[The use of the grid is optional.]

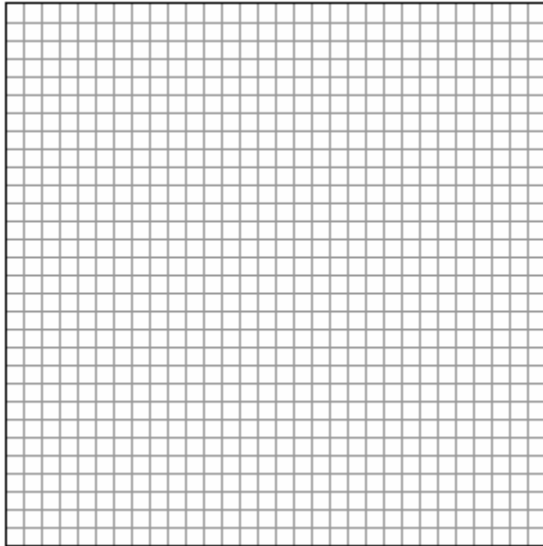

290. The accompanying diagram shows the graphs of a linear equation and a quadratic equation.

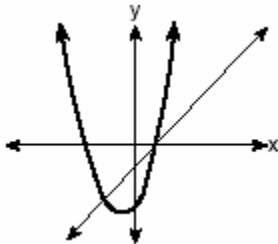

How many solutions are there to this system of equations?

- [A] 0      [B] 3      [C] 2      [D] 1

291. A pelican flying in the air over water drops a crab from a height of 30 feet. The distance the crab is from the water as it falls can be represented by the function  $h(t) = -16t^2 + 30$ , where  $t$  is time, in seconds. To catch the crab as it falls, a gull flies along a path represented by the function  $g(t) = -8t + 15$ . Can the gull catch the crab before the crab hits the water? Justify your answer. [The use of the accompanying grid is optional.]

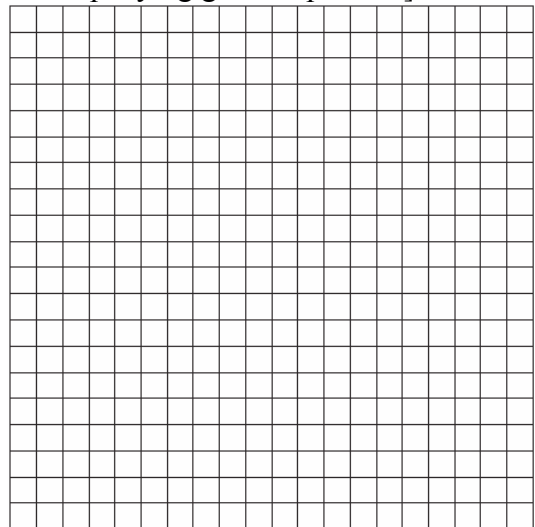

292. The price of a stock,  $A(x)$ , over a 12-month period decreased and then increased according to the equation  $A(x) = 0.75x^2 - 6x + 20$ , where  $x$  equals the number of months. The price of another stock,  $B(x)$ , increased according to the equation  $B(x) = 2.75x + 1.50$  over the same 12-month period. Graph and label both equations on the accompanying grid. State all prices, to the *nearest dollar*, when both stock values were the same.

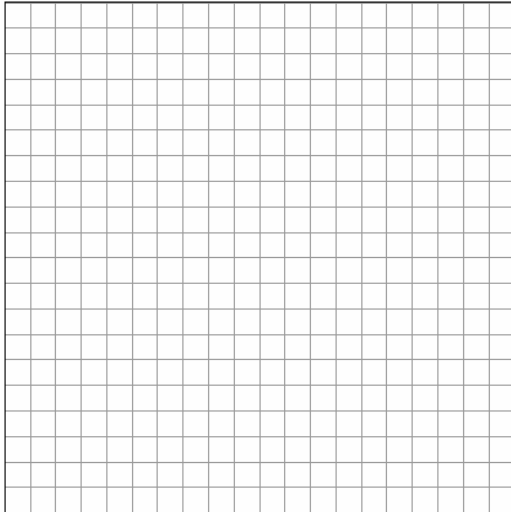

## ALGEBRA CHAPTER 7-1

293. Which quadratic function is shown in the accompanying graph?

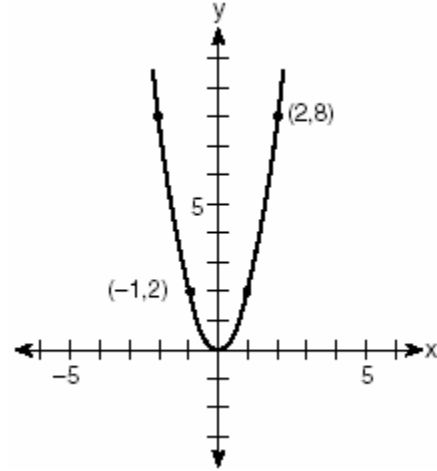

- [A]  $y = -\frac{1}{2}x^2$       [B]  $y = 2x^2$   
 [C]  $y = \frac{1}{2}x^2$       [D]  $y = -2x^2$

## ALGEBRA CHAPTER 7-3

294. Amy tossed a ball in the air in such a way that the path of the ball was modeled by the equation  $y = -x^2 + 6x$ . In the equation,  $y$  represents the height of the ball in feet and  $x$  is the time in seconds.

a Graph  $y = -x^2 + 6x$  for  $0 \leq x \leq 6$  on the grid provided below.

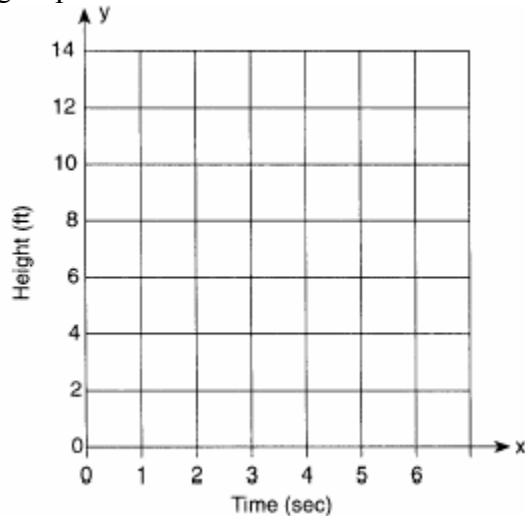

b At what time,  $x$ , is the ball at its highest point?

295. An architect is designing a museum entranceway in the shape of a parabolic arch represented by the equation  $y = -x^2 + 20x$ , where  $0 \leq x \leq 20$  and all dimensions are expressed in feet. On the accompanying set of axes, sketch a graph of the arch and determine its maximum height, in feet.

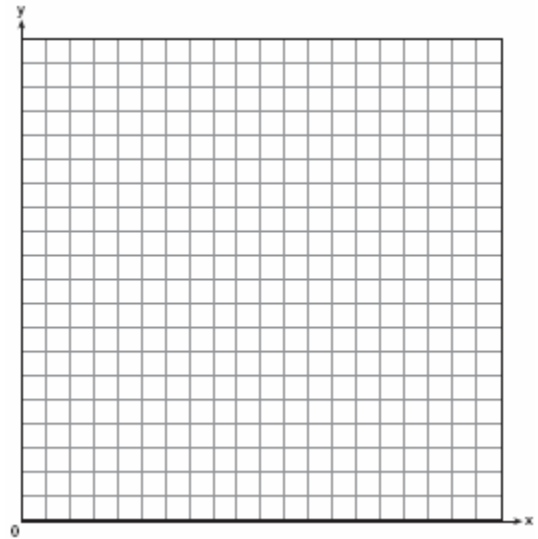



296. Tom throws a ball into the air. The ball travels on a parabolic path represented by the equation  $h = -8t^2 + 40t$ , where  $h$  is the height, in feet, and  $t$  is the time, in seconds.  
a On the accompanying set of axes, graph the equation from  $t = 0$  to  $t = 5$  seconds, including all integral values of  $t$  from 0 to 5.

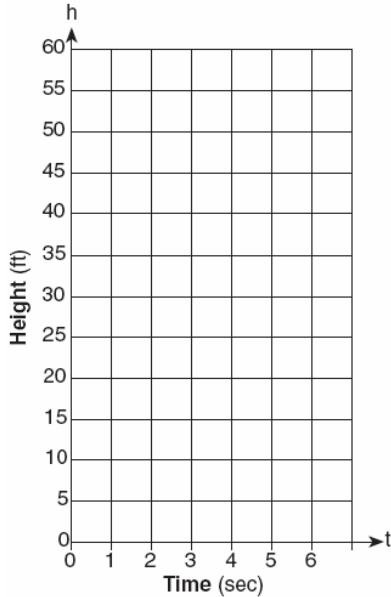

- b What is the value of  $t$  at which  $h$  has its greatest value?

297. An arch is built so that it is 6 feet wide at the base. Its shape can be represented by a parabola with the equation  $y = -2x^2 + 12x$ , where  $y$  is the height of the arch.  
a Graph the parabola from  $x = 0$  to  $x = 6$  on the grid below.

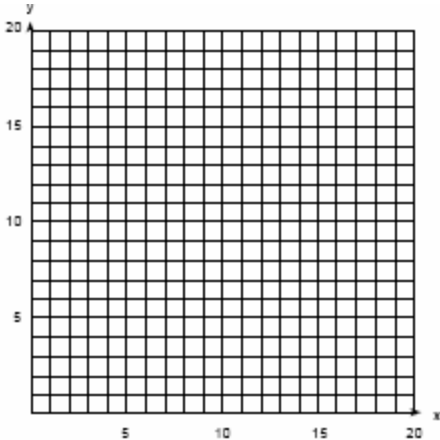

- b Determine the maximum height,  $y$ , of the arch.

298. Which is an equation of the parabola shown in the accompanying diagram?

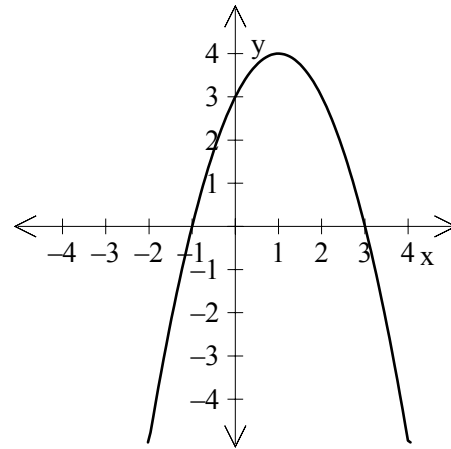

- [A]  $y = -x^2 + 2x + 3$       [B]  $y = -x^2 - 2x + 3$   
[C]  $y = x^2 - 2x + 3$       [D]  $y = x^2 + 2x + 3$

299. What is the equation of a parabola that goes through points  $(0,1)$ ,  $(-1,6)$ , and  $(2,3)$ ?

- [A]  $y = x^2 - 3x + 1$       [B]  $y = x^2 + 1$   
[C]  $y = 2x^2 - 3x + 1$       [D]  $y = 2x^2 + 1$

300. For which quadratic equation is the axis of symmetry  $x = 3$ ?

- [A]  $y = -x^2 + 3x + 5$       [B]  $y = -x^2 + 6x + 2$   
[C]  $y = x^2 + x + 3$       [D]  $y = x^2 + 6x + 3$

## ALGEBRA CHAPTER 7-4

301. The expression  $\sqrt{93}$  is a number between

- [A] 8 and 9      [B] 3 and 9  
[C] 9 and 10      [D] 46 and 47

302. The amount of time,  $t$ , in seconds, it takes an object to fall a distance,  $d$ , in meters, is expressed by the formula  $t = \sqrt{\frac{d}{4.9}}$ .
- Approximately how long will it take an object to fall 75 meters?
- [A] 3.9 sec                      [B] 7.7 sec  
[C] 0.26 sec                    [D] 2.34 sec

305. Greg is in a car at the top of a roller-coaster ride. The distance,  $d$ , of the car from the ground as the car descends is determined by the equation  $d = 144 - 16t^2$ , where  $t$  is the number of seconds it takes the car to travel down to each point on the ride. How many seconds will it take Greg to reach the ground? For an algebraic solution show your work here.  
For a graphic solution show your work here.

## ALGEBRA CHAPTER 7-5

303. What is the solution set of the equation  $3x^2 = 48$ ?
- [A]  $\{-2,-8\}$                       [B]  $\{4,-4\}$   
[C]  $\{2,8\}$                           [D]  $\{4,4\}$
304. The height of a golf ball hit into the air is modeled by the equation  $h = -16t^2 + 48t$ , where  $h$  represents the height, in feet, and  $t$  represents the number of seconds that have passed since the ball was hit. What is the height of the ball after 2 seconds?
- [A] 80 ft    [B] 16 ft    [C] 32 ft    [D] 64 ft

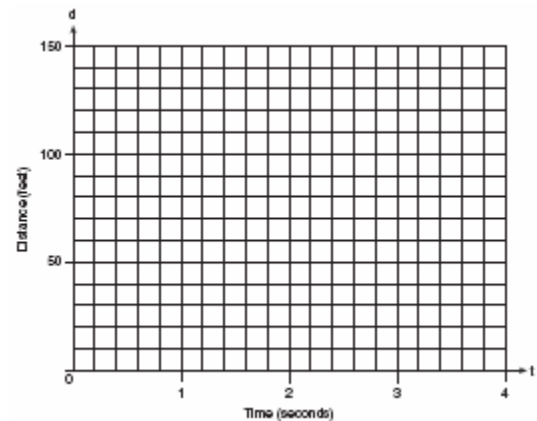

306. An acorn falls from the branch of a tree to the ground 25 feet below. The distance,  $S$ , the acorn is from the ground as it falls is represented by the equation  $S(t) = -16t^2 + 25$ , where  $t$  represents time, in seconds. Sketch a graph of this situation on the accompanying grid. Calculate, to the *nearest hundredth of a second*, the time the acorn will take to reach the ground.

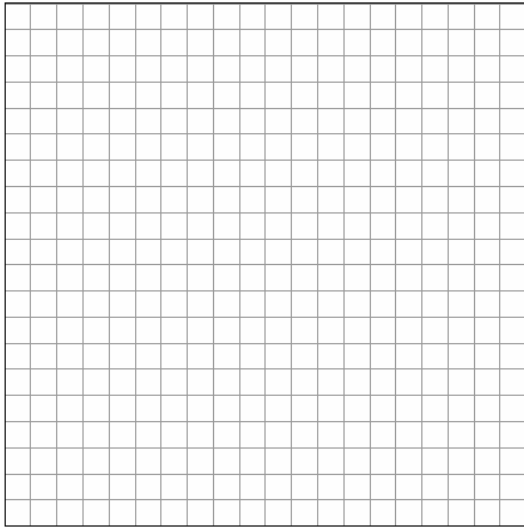

310. What is the value of  $2^{-3}$ ?  
[A]  $\frac{1}{6}$  [B] -8 [C]  $\frac{1}{8}$  [D] -6
311. Solve for  $x$ :  $x^{-3} = \frac{27}{64}$

## ALGEBRA CHAPTER 8-5

312. Expressed in decimal notation,  $4.726 \times 10^{-3}$  is  
[A] 472.6 [B] 0.004726  
[C] 4,726 [D] 0.04726
313. The number  $8.375 \times 10^{-3}$  is equivalent to  
[A] 0.08375 [B] 0.0008375  
[C] 8,375 [D] 0.008375
314. The number  $1.56 \times 10^{-2}$  is equivalent to  
[A] 0.0156 [B] 156  
[C] 0.156 [D] 0.00156
315. Which expression is equivalent to  $6.02 \times 10^{23}$ ?  
[A]  $6020 \times 10^{21}$  [B]  $0.602 \times 10^{21}$   
[C]  $602 \times 10^{21}$  [D]  $60.2 \times 10^{21}$
316. If 0.0347 is written by a scientist in the form  $3.47 \times 10^n$ , the value of  $n$  is  
[A] 2 [B] -3 [C] -2 [D] 3
317. The distance from Earth to the Sun is approximately 93 million miles. A scientist would write that number as  
[A]  $9.3 \times 10^6$  [B]  $9.3 \times 10^7$   
[C]  $93 \times 10^{10}$  [D]  $93 \times 10^7$

## ALGEBRA CHAPTER 8-4

307. What is the value of  $3^{-2}$ ?  
[A]  $-\frac{1}{9}$  [B]  $\frac{1}{9}$  [C] 9 [D] -9
308. Which expression is equivalent to  $x^{-1} \cdot y^2$ ?  
[A]  $\frac{x}{y^2}$  [B]  $\frac{y^2}{x}$  [C]  $xy^2$  [D]  $xy^{-2}$
309. Which expression is equivalent to  $x^{-4}$ ?  
[A]  $-4x$  [B] 0 [C]  $\frac{1}{x^4}$  [D]  $x^4$

318. The approximate number of seconds in a year is 32,000,000. When this number is written in scientific notation, the numerical value of the exponent is  
[A] 8 [B] -7 [C] 7 [D] 6
319. The mass of an orchid seed is approximately 0.0000035 gram. Written in scientific notation, that mass is equivalent to  $3.5 \times 10^n$ . What is the value of  $n$ ?  
[A] -8 [B] -5 [C] -7 [D] -6
320. The expression  $0.62 \times 10^3$  is equivalent to  
[A] 0.062 [B] 62,000  
[C]  $6.2 \times 10^2$  [D]  $6.2 \times 10^4$
321. If  $3.85 \times 10^6$  is divided by  $385 \times 10^4$ , the result is  
[A] 0.01 [B]  $3.85 \times 10^{10}$   
[C]  $3.85 \times 10^4$  [D] 1
322. What is the value of  $\frac{6.3 \times 10^8}{3 \times 10^4}$  in scientific notation?  
[A]  $2.1 \times 10^{-2}$  [B]  $2.1 \times 10^2$   
[C]  $2.1 \times 10^4$  [D]  $2.1 \times 10^{-4}$
323. If the number of molecules in 1 mole of a substance is  $6.02 \times 10^{23}$ , then the number of molecules in 100 moles is  
[A]  $6.02 \times 10^{25}$  [B]  $6.02 \times 10^{24}$   
[C]  $6.02 \times 10^{22}$  [D]  $6.02 \times 10^{21}$
324. If the mass of a proton is  $1.67 \times 10^{-24}$  gram, what is the mass of 1,000 protons?  
[A]  $1.67 \times 10^{-23}$  [B]  $1.67 \times 10^{-27}$   
[C]  $1.67 \times 10^{-21}$  [D]  $1.67 \times 10^{-22}$
325. The distance from Earth to the imaginary planet Med is  $1.7 \times 10^7$  miles. If a spaceship is capable of traveling 1,420 miles per hour, how many days will it take the spaceship to reach the planet Med? Round your answer to the nearest day.
326. Two objects are  $2.4 \times 10^{20}$  centimeters apart. A message from one object travels to the other at a rate of  $1.2 \times 10^5$  centimeters per second. How many seconds does it take the message to travel from one object to the other?  
[A]  $2.0 \times 10^4$  [B]  $2.0 \times 10^{15}$   
[C]  $1.2 \times 10^{15}$  [D]  $2.88 \times 10^{25}$

## ALGEBRA CHAPTER 8-6

327. The expression  $8^{-4} \cdot 8^6$  is equivalent to  
[A]  $8^{10}$  [B]  $8^{-2}$  [C]  $8^2$  [D]  $8^{-24}$
328. The expression  $3^2 \cdot 3^3 \cdot 3^4$  is equivalent to  
[A]  $27^9$  [B]  $3^{24}$  [C]  $3^9$  [D]  $27^{24}$
329. The expression  $2^3 \cdot 4^2$  is equivalent to  
[A]  $8^5$  [B]  $8^6$  [C]  $2^7$  [D]  $2^{12}$
330. The expression  $(x^2z^3)(xy^2z)$  is equivalent to  
[A]  $x^2y^2z^3$  [B]  $x^3y^2z^4$   
[C]  $x^4y^2z^5$  [D]  $x^3y^3z^4$
331. The product of  $2x^3$  and  $6x^5$  is  
[A]  $10x^{15}$  [B]  $12x^8$   
[C]  $12x^{15}$  [D]  $10x^8$
332. The product of  $3x^2y$  and  $-4xy^3$  is  
[A]  $12x^2y^3$  [B]  $-12x^3y^4$   
[C]  $-12x^2y^3$  [D]  $12x^3y^4$

333. The product of  $3x^5$  and  $2x^4$  is  
 [A]  $6x^{20}$  [B]  $6x^9$  [C]  $5x^9$  [D]  $5x^{20}$
334. The product of  $4x^2y$  and  $2xy^3$  is  
 [A]  $8x^2y^4$  [B]  $8x^3y^3$   
 [C]  $8x^2y^3$  [D]  $8x^3y^4$

340. The expression  $\frac{5x^6y^2}{x^8y}$  is equivalent to  
 [A]  $5x^2y$  [B]  $\frac{5y^3}{x^{14}}$   
 [C]  $\frac{5y}{x^2}$  [D]  $5x^{14}y^3$

341. The expression  $\frac{(b^{2n+1})^3}{b^n \cdot b^{4n+3}}$  is equivalent to

- [A]  $b^{-3n}$  [B]  $b^{-3n+1}$  [C]  $b^n$  [D]  $\frac{b^n}{2}$

## ALGEBRA CHAPTER 8-7

335. Expressed in its simplest form,  $(3x^3)(2y)^2(4x^4)$  is equivalent to  
 [A]  $24x^{12}y^2$  [B]  $24x^7y^2$   
 [C]  $48x^{12}y^2$  [D]  $48x^7y^2$
336. The product of  $(5ab)$  and  $(-2a^2b)^3$  is  
 [A]  $-40a^7b^4$  [B]  $-30a^7b^4$   
 [C]  $-40a^6b^4$  [D]  $-30a^6b^4$

## ALGEBRA CHAPTER 8-8

337. When  $-9x^5$  is divided by  $-3x^3$ ,  $x \neq 0$ , the quotient is  
 [A]  $3x^2$  [B]  $-3x^2$   
 [C]  $-27x^{15}$  [D]  $27x^8$
338. The quotient of  $-\frac{15x^8}{5x^2}$ ,  $x \neq 0$ , is  
 [A]  $-10x^6$  [B]  $-10x^4$   
 [C]  $-3x^6$  [D]  $-3x^4$
339. If  $x \neq 0$ , then  $\frac{(x^2)^3}{x^5} \cdot 1000$  is equivalent to  
 [A] 1000 [B] 0  
 [C]  $1000x$  [D]  $1000 + x$

## ALGEBRA CHAPTER 9-1

342. In the accompanying diagram, triangle  $A$  is similar to triangle  $B$ . Find the value of  $n$ .

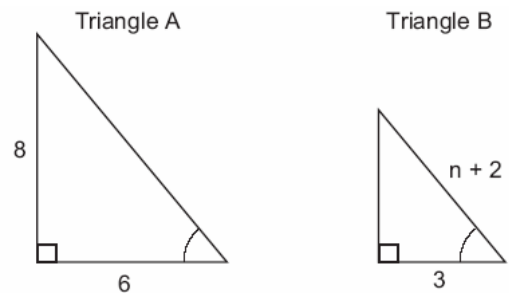

343. A wall is supported by a brace 10 feet long, as shown in the diagram below. If one end of the brace is placed 6 feet from the base of the wall, how many feet up the wall does the brace reach?

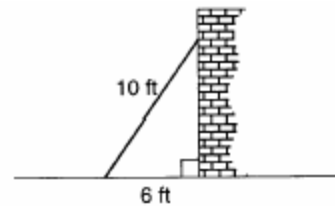

344. The NuFone Communications Company must run a telephone line between two poles at opposite ends of a lake, as shown in the accompanying diagram. The length and width of the lake are 75 feet and 30 feet, respectively.

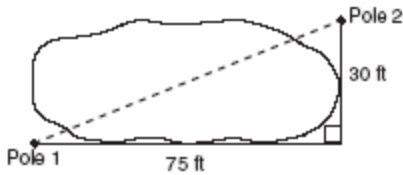

What is the distance between the two poles, to the nearest foot?

- [A] 45    [B] 81    [C] 69    [D] 105
345. How many feet from the base of a house must a 39-foot ladder be placed so that the top of the ladder will reach a point on the house 36 feet from the ground?
346. A woman has a ladder that is 13 feet long. If she sets the base of the ladder on level ground 5 feet from the side of a house, how many feet above the ground will the top of the ladder be when it rests against the house?
- [A] 12    [B] 11    [C] 9    [D] 8
347. If the length of the legs of a right triangle are 5 and 7, what is the length of the hypotenuse?
- [A]  $2\sqrt{3}$                       [B]  $\sqrt{2}$   
[C]  $\sqrt{74}$                         [D]  $2\sqrt{6}$
348. The set of integers  $\{3,4,5\}$  is a Pythagorean triple. Another such set is
- [A]  $\{8,15,17\}$                       [B]  $\{6,12,13\}$   
[C]  $\{6,7,8\}$                         [D]  $\{6,8,12\}$

349. A straw is placed into a rectangular box that is 3 inches by 4 inches by 8 inches, as shown in the accompanying diagram. If the straw fits exactly into the box diagonally from the bottom left front corner to the top right back corner, how long is the straw, to the nearest tenth of an inch?

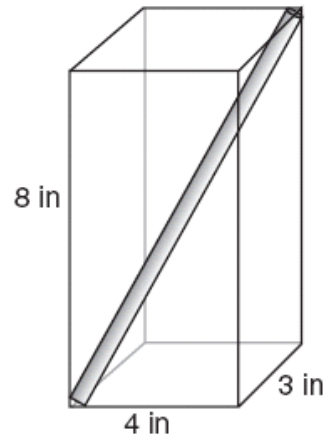

350. The accompanying diagram shows a kite that has been secured to a stake in the ground with a 20-foot string. The kite is located 12 feet from the ground, directly over point X. What is the distance, in feet, between the stake and point X?

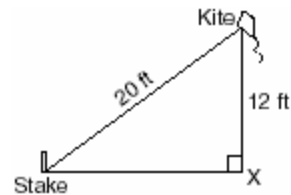

## ALGEBRA CHAPTER 9-2

351. Determine the distance between point  $A(-1,-3)$  and point  $B(5,5)$ . Write an equation of the perpendicular bisector of  $\overline{AB}$ . [The use of the accompanying grid is optional.]

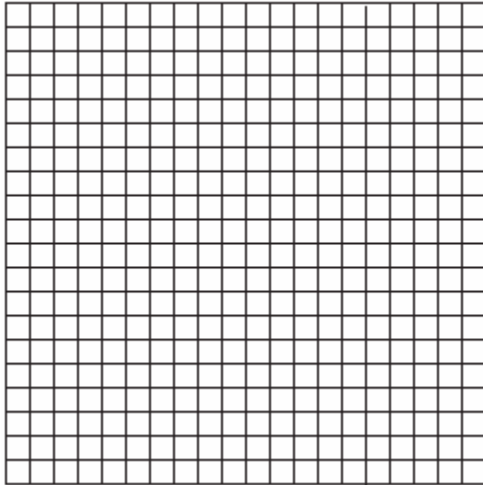

352. The coordinates of point  $R$  are  $(-3,2)$  and the coordinates of point  $T$  are  $(4,1)$ . What is the length of  $\overline{RT}$ ?
- [A]  $5\sqrt{2}$                       [B]  $4\sqrt{3}$   
 [C]  $2\sqrt{2}$                       [D]  $\sqrt{10}$

353. Jerry and Jean Jogger start at the same time from point A shown on the accompanying set of axes. Jerry jogs at a rate of 5 miles per hour traveling from point A to point R to point S and then to point C. Jean jogs directly from point A to point C on  $\overline{AC}$  at the rate of 3 miles per hour. Which jogger reaches point C first? Explain or show your reasoning.

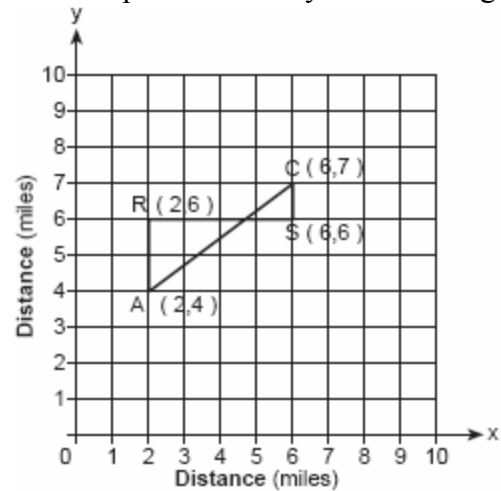

354. Katrina hikes 5 miles north, 7 miles east, and then 3 miles north again. To the *nearest tenth of a mile*, how far, in a straight line, is Katrina from her starting point?

355. To get from his high school to his home, Jamal travels 5.0 miles east and then 4.0 miles north. When Sheila goes to her home from the same high school, she travels 8.0 miles east and 2.0 miles south. What is the measure of the shortest distance, to the *nearest tenth of a mile*, between Jamal's home and Sheila's home? [The use of the accompanying grid is optional.]

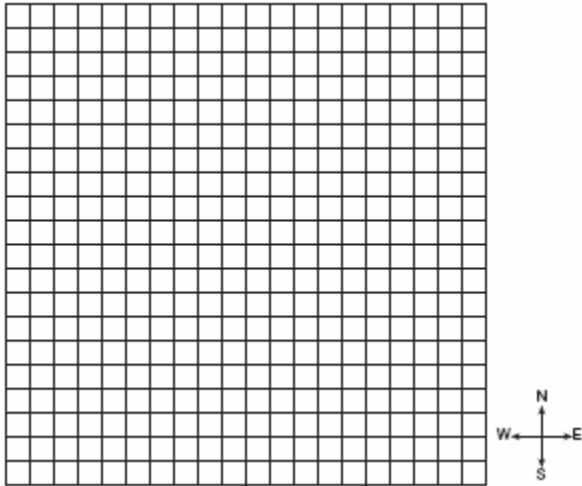

356. The coordinates of the midpoint of  $\overline{AB}$  are (2,4), and the coordinates of point  $B$  are (3,7). What are the coordinates of point  $A$ ? [The use of the accompanying grid is optional.]

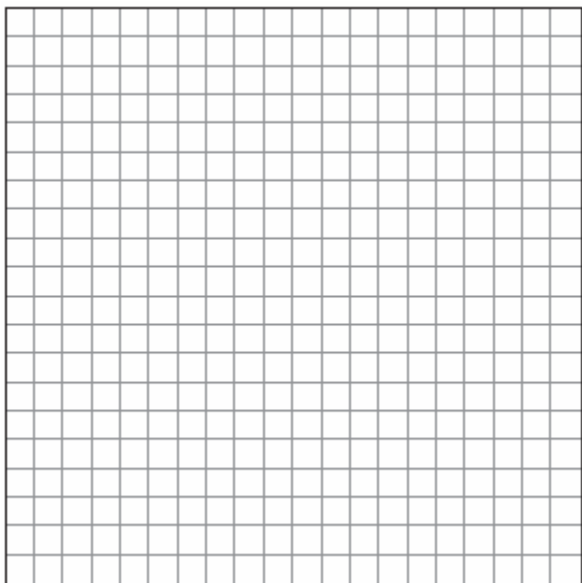

357. The midpoint  $M$  of line segment  $AB$  has coordinates (-3,4). If point  $A$  is the origin, (0,0), what are the coordinates of point  $B$ ? [The use of the accompanying grid is optional.]

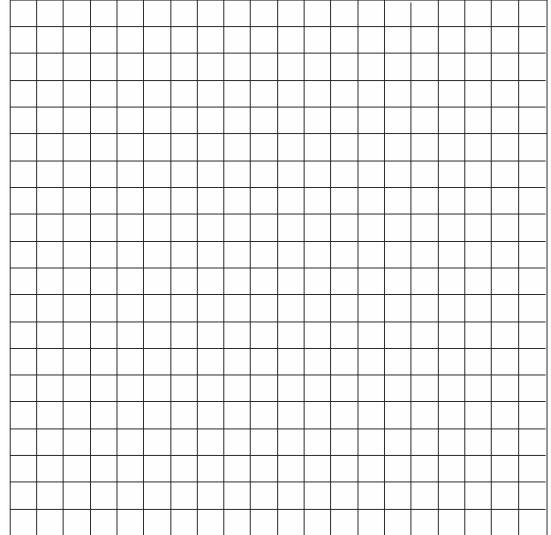

358.  $M$  is the midpoint of  $\overline{AB}$ . If the coordinates of  $A$  are (-1,5) and the coordinates of  $M$  are (3,3), what are the coordinates of  $B$ ?

- [A] (1,4)                      [B] (7,1)  
 [C] (2,8)                      [D] (-5,7)

359. A line segment on the coordinate plane has endpoints (2,4) and (4, $y$ ). The midpoint of the segment is point (3,7). What is the value of  $y$ ?

- [A] 5            [B] -2            [C] 10            [D] 11



## ALGEBRA CHAPTER 9-3

360. Which ratio represents  $\cos A$  in the accompanying diagram of  $\triangle ABC$ ?

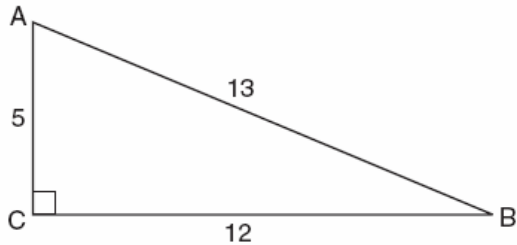

- [A]  $\frac{12}{13}$     [B]  $\frac{13}{5}$     [C]  $\frac{5}{13}$     [D]  $\frac{12}{5}$

361. In the accompanying diagram of right triangle  $ABC$ ,  $AB = 8$ ,  $BC = 15$ ,  $AC = 17$ , and  $m\angle ABC = 90$ .

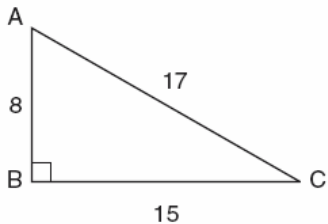

What is  $\tan \angle C$ ?

- [A]  $\frac{8}{17}$     [B]  $\frac{15}{17}$     [C]  $\frac{8}{15}$     [D]  $\frac{17}{15}$

362. The angle of elevation from a point 25 feet from the base of a tree on level ground to the top of the tree is  $30^\circ$ . Which equation can be used to find the height of the tree?

- [A]  $\cos 30^\circ = \frac{x}{25}$     [B]  $30^2 + 25^2 = x^2$   
[C]  $\sin 30^\circ = \frac{x}{25}$     [D]  $\tan 30^\circ = \frac{x}{25}$

363. Joe is holding his kite string 3 feet above the ground, as shown in the accompanying diagram. The distance between his hand and a point directly under the kite is 95 feet. If the angle of elevation to the kite is  $50^\circ$ , find the height,  $h$ , of his kite, to the nearest foot.

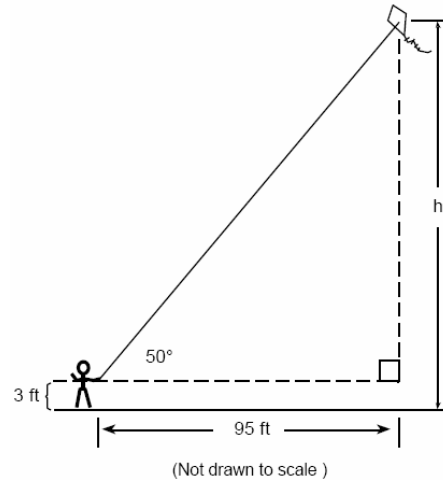

364. A person standing on level ground is 2,000 feet away from the foot of a 420-foot-tall building, as shown in the accompanying diagram. To the nearest degree, what is the value of  $x$ ?

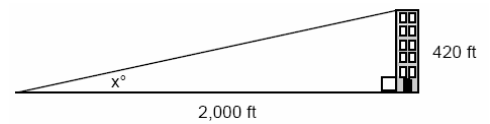

365. A surveyor needs to determine the distance across the pond shown in the accompanying diagram. She determines that the distance from her position to point  $P$  on the south shore of the pond is 175 meters and the angle from her position to point  $X$  on the north shore is  $32^\circ$ . Determine the distance,  $PX$ , across the pond, rounded to the nearest meter.

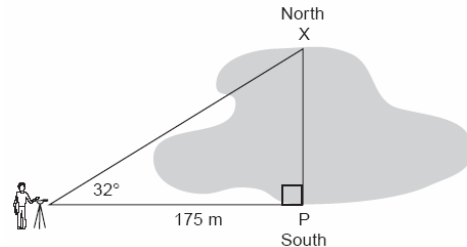

366. A 10-foot ladder is to be placed against the side of a building. The base of the ladder must be placed at an angle of  $72^\circ$  with the level ground for a secure footing. Find, to the *nearest inch*, how far the base of the ladder should be from the side of the building and how far up the side of the building the ladder will reach.

367. Find, to the *nearest tenth of a foot*, the height of the tree represented in the accompanying diagram.

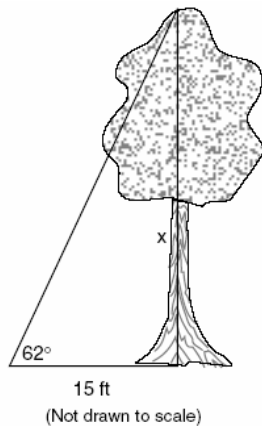

368. A ship on the ocean surface detects a sunken ship on the ocean floor at an angle of depression of  $50^\circ$ . The distance between the ship on the surface and the sunken ship on the ocean floor is 200 meters. If the ocean floor is level in this area, how far above the ocean floor, to the *nearest meter*, is the ship on the surface?

369. As seen in the accompanying diagram, a person can travel from New York City to Buffalo by going north 170 miles to Albany and then west 280 miles to Buffalo.

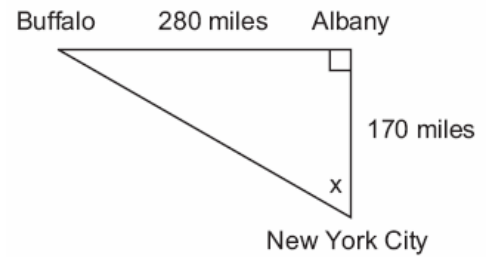

*a* If an engineer wants to design a highway to connect New York City directly to Buffalo, at what angle,  $x$ , would she need to build the highway? Find the angle to the *nearest degree*.

*b* To the *nearest mile*, how many miles would be saved by traveling directly from New York City to Buffalo rather than by traveling first to Albany and then to Buffalo?

370. In the accompanying diagram, the base of a 15-foot ladder rests on the ground 4 feet from a 6-foot fence.

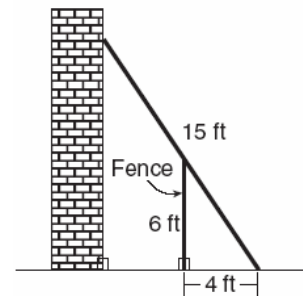

*a* If the ladder touches the top of the fence and the side of a building, what angle, to the *nearest degree*, does the ladder make with the ground?

*b* Using the angle found in part *a*, determine how far the top of the ladder reaches up the side of the building, to the *nearest foot*.

371. In the accompanying diagram, a ladder leaning against a building makes an angle of  $58^\circ$  with level ground. If the distance from the foot of the ladder to the building is 6 feet, find, to the *nearest foot*, how far up the building the ladder will reach.



372. Draw and label a diagram of the path of an airplane climbing at an angle of  $11^\circ$  with the ground. Find, to the *nearest foot*, the ground distance the airplane has traveled when it has attained an altitude of 400 feet.

373. In the accompanying diagram,  $x$  represents the length of a ladder that is leaning against a wall of a building, and  $y$  represents the distance from the foot of the ladder to the base of the wall. The ladder makes a  $60^\circ$  angle with the ground and reaches a point on the wall 17 feet above the ground. Find the number of feet in  $x$  and  $y$ .

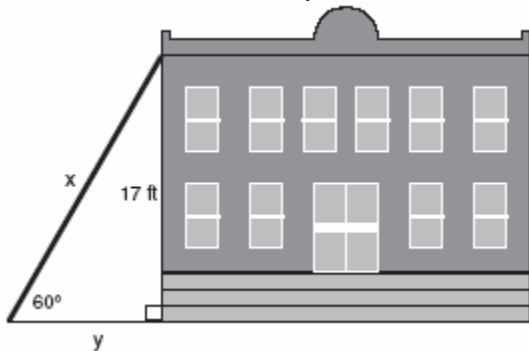

374. The accompanying diagram shows a flagpole that stands on level ground. Two cables,  $r$  and  $s$ , are attached to the pole at a point 16 feet above the ground. The combined length of the two cables is 50 feet. If cable  $r$  is attached to the ground 12 feet from the base of the pole, what is the measure of the angle,  $x$ , to the *nearest degree*, that cable  $s$  makes with the ground?

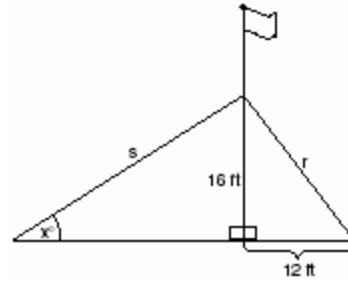

375. A tree casts a shadow that is 20 feet long. The angle of elevation from the end of the shadow to the top of the tree is  $66^\circ$ . Determine the height of the tree, to the *nearest foot*.

## ALGEBRA CHAPTER 9-4

376. Which expression is equivalent to  $\frac{4}{3+\sqrt{2}}$ ?

[A]  $\frac{12+4\sqrt{2}}{7}$

[B]  $\frac{12-4\sqrt{2}}{11}$

[C]  $\frac{12-4\sqrt{2}}{7}$

[D]  $\frac{12+4\sqrt{2}}{11}$

377. Which expression is equal to  $\frac{2+\sqrt{3}}{2-\sqrt{3}}$ ?

[A]  $\frac{1-4\sqrt{3}}{7}$

[B]  $7+4\sqrt{3}$

[C]  $\frac{7+4\sqrt{3}}{7}$

[D]  $1-4\sqrt{3}$

378. The expression  $\frac{7}{2-\sqrt{3}}$  is equivalent to

[A]  $\frac{2+\sqrt{3}}{7}$  [B]  $\frac{14+\sqrt{3}}{7}$

[C]  $14+7\sqrt{3}$  [D]  $14-7\sqrt{3}$

379. The expression  $\frac{11}{\sqrt{3}-5}$  is equivalent to

[A]  $\frac{\sqrt{3}-5}{2}$  [B]  $\frac{-\sqrt{3}-5}{2}$

[C]  $\frac{\sqrt{3}+5}{2}$  [D]  $\frac{-\sqrt{3}+5}{2}$

380. The expression  $\frac{7}{3-\sqrt{2}}$  is equivalent to

[A]  $\frac{21+\sqrt{2}}{7}$  [B]  $\frac{3+\sqrt{2}}{7}$

[C]  $3-\sqrt{2}$  [D]  $3+\sqrt{2}$

381. The expression  $\frac{1}{5-\sqrt{13}}$  is equivalent to

[A]  $\frac{5+\sqrt{13}}{-12}$  [B]  $\frac{5+\sqrt{13}}{8}$

[C]  $\frac{5+\sqrt{13}}{-8}$  [D]  $\frac{5+\sqrt{13}}{12}$

382. Which expression represents the sum of  $\frac{1}{\sqrt{3}} + \frac{1}{\sqrt{2}}$ ?

[A]  $\frac{2\sqrt{3}+3\sqrt{2}}{6}$  [B]  $\frac{\sqrt{3}+\sqrt{2}}{3}$

[C]  $\frac{2}{\sqrt{5}}$  [D]  $\frac{\sqrt{3}+\sqrt{2}}{2}$

383. The expression  $\sqrt{50}$  can be simplified to

[A]  $5\sqrt{10}$  [B]  $25\sqrt{2}$

[C]  $5\sqrt{2}$  [D]  $2\sqrt{25}$

384. Simplify:  $\sqrt{50r^2s^4}$

385. If  $x > 0$ , the expression  $(\sqrt{x})(\sqrt{2x})$  is equivalent to

[A]  $\sqrt{2x}$  [B]  $2x$

[C]  $x^2\sqrt{2}$  [D]  $x\sqrt{2}$

386. If  $a > 0$ , then  $\sqrt{9a^2+16a^2}$  equals

[A]  $5a$  [B]  $5\sqrt{a}$  [C]  $\sqrt{7a}$  [D]  $7a$

387. When  $\sqrt{72}$  is expressed in simplest  $a\sqrt{b}$  form, what is the value of  $a$ ?

[A] 2 [B] 8 [C] 6 [D] 3

## ALGEBRA CHAPTER 9-5

388. The sum of  $\sqrt{18}$  and  $\sqrt{72}$  is

[A]  $3\sqrt{10}$  [B]  $6\sqrt{3}$

[C]  $9\sqrt{2}$  [D]  $\sqrt{90}$

389. The sum of  $\sqrt{75}$  and  $\sqrt{3}$  is

[A] 18 [B]  $\sqrt{78}$  [C]  $6\sqrt{3}$  [D] 15

390. The expression  $\sqrt{27} + \sqrt{12}$  is equivalent to

[A]  $13\sqrt{3}$  [B]  $\sqrt{39}$

[C]  $5\sqrt{6}$  [D]  $5\sqrt{3}$

391. The expression  $2\sqrt{50} - \sqrt{2}$  is equivalent to

[A] 10 [B]  $2\sqrt{48}$

[C]  $9\sqrt{2}$  [D]  $49\sqrt{2}$

392. The expression  $\sqrt{90} \cdot \sqrt{40} - \sqrt{8} \cdot \sqrt{18}$  simplifies to  
[A] 48 [B] 3,456 [C] 864 [D] 22.9
393. The expression  $\sqrt{50} + \sqrt{32}$  is equivalent to  
[A]  $\sqrt{82}$  [B] 6 [C] 18 [D]  $9\sqrt{2}$
394. What is the sum of  $5\sqrt{7}$  and  $3\sqrt{28}$ ?  
[A]  $11\sqrt{7}$  [B]  $60\sqrt{7}$   
[C]  $9\sqrt{7}$  [D]  $8\sqrt{35}$

## ALGEBRA CHAPTER 9-6

395. The solution set of the equation  $\sqrt{x+6} = x$  is  
[A]  $\{-2,3\}$  [B]  $\{\}$  [C]  $\{-2\}$  [D]  $\{3\}$
396. What is the solution set of the equation  $x = 2\sqrt{2x-3}$ ?  
[A]  $\{\}$  [B]  $\{2\}$  [C]  $\{2,6\}$  [D]  $\{6\}$
397. Solve algebraically:  $\sqrt{x+5} + 1 = x$
398. What is the solution set of the equation  $\sqrt{9x+10} = x$   
[A]  $\{-1\}$  [B]  $\{10\}$   
[C]  $\{9\}$  [D]  $\{10, -1\}$
399. Solve for all values of  $q$  that satisfy the equation  $\sqrt{3q+7} = q+3$ .
400. A wrecking ball suspended from a chain is a type of pendulum. The relationship between the rate of speed of the ball,  $R$ , the mass of the ball,  $m$ , the length of the chain,  $L$ , and the force,  $F$ , is  $R = 2\pi\sqrt{\frac{mL}{F}}$ . Determine the force,  $F$ , to the nearest hundredth, when  $L = 12$ ,  $m = 50$ , and  $R = 0.6$ .

401. The lateral surface area of a right circular cone,  $s$ , is represented by the equation  $s = \pi r\sqrt{r^2 + h^2}$ , where  $r$  is the radius of the circular base and  $h$  is the height of the cone. If the lateral surface area of a large funnel is 236.64 square centimeters and its radius is 4.75 centimeters, find its height, to the nearest hundredth of a centimeter.
402. The equation  $V = 20\sqrt{C+273}$  relates speed of sound,  $V$ , in meters per second, to air temperature,  $C$ , in degrees Celsius. What is the temperature, in degrees Celsius, when the speed of sound is 320 meters per second? [The use of the accompanying grid is optional.]

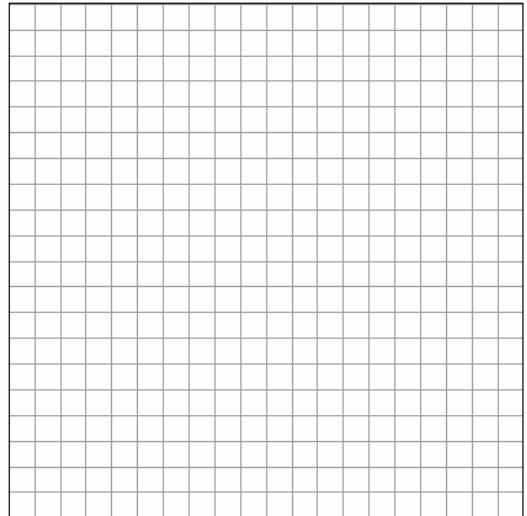

403. The number of people,  $y$ , involved in recycling in a community is modeled by the function  $y = 90\sqrt{3x} + 400$ , where  $x$  is the number of months the recycling plant has been open.

Construct a table of values, sketch the function on the grid, and find the number of people involved in recycling exactly 3 months after the plant opened.

After how many months will 940 people be involved in recycling?

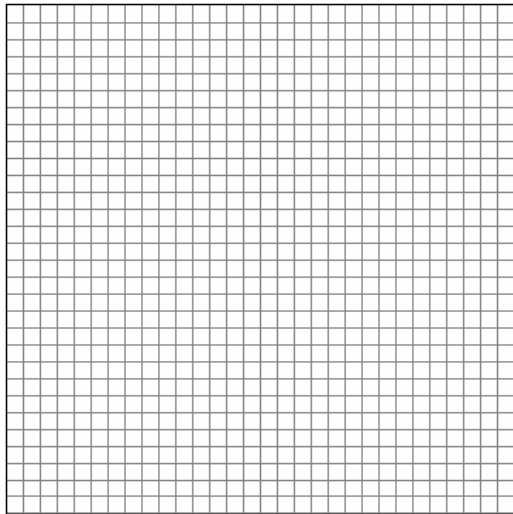

### ALGEBRA CHAPTER 9-7

404. What is the domain of  $h(x) = \sqrt{x^2 - 4x - 5}$ ?
- [A]  $\{x|x \geq 1 \text{ or } x \leq -5\}$   
 [B]  $\{x|-1 \leq x \leq 5\}$   
 [C]  $\{x|-5 \leq x \leq 1\}$       [D]  $\{x|x \geq 5 \text{ or } x \leq -1\}$
405. Which statement is true for all real number values of  $x$ ?
- [A]  $|x - 1| > (x - 1)$       [B]  $\sqrt{x^2} = x$   
 [C]  $|x - 1| > 0$       [D]  $\sqrt{x^2} = |x|$

406. What is the axis of symmetry of the graph of the equation  $x = y^2$ ?

- [A] line  $y = x$       [B]  $x$ -axis  
 [C]  $y$ -axis      [D] line  $y = -x$

### ALGEBRA CHAPTER 10-1

407. The sum of  $3x^2 + x + 8$  and  $x^2 - 9$  can be expressed as
- [A]  $3x^4 + x - 1$       [B]  $4x^4 + x - 1$   
 [C]  $4x^2 + x - 17$       [D]  $4x^2 + x - 1$
408. The sum of  $3x^2 + 4x - 2$  and  $x^2 - 5x + 3$  is
- [A]  $4x^2 + x - 1$       [B]  $4x^2 + x + 1$   
 [C]  $4x^2 - x + 1$       [D]  $4x^2 - x - 1$
409. If  $2x^2 - 4x + 6$  is subtracted from  $5x^2 + 8x - 2$ , the difference is
- [A]  $3x^2 + 12x - 8$       [B]  $-3x^2 + 4x + 4$   
 [C]  $3x^2 + 4x + 4$       [D]  $-3x^2 - 12x + 8$
410. The expression  $(3x^2 + 2xy + 7) - (6x^2 - 4xy + 3)$  is equivalent to
- [A]  $-3x^2 - 2xy + 4$       [B]  $3x^2 - 2xy + 4$   
 [C]  $-3x^2 + 6xy + 4$       [D]  $3x^2 - 6xy - 4$
411. When  $3a^2 - 2a + 5$  is subtracted from  $a^2 + a - 1$ , the result is
- [A]  $-2a^2 + 3a - 6$       [B]  $-2a^2 + 3a + 6$   
 [C]  $2a^2 - 3a + 6$       [D]  $2a^2 - 3a - 6$
412. When  $3x^2 - 2x + 1$  is subtracted from  $2x^2 + 7x + 5$ , the result will be
- [A]  $x^2 - 9x - 4$       [B]  $-x^2 + 9x + 4$   
 [C]  $-x^2 + 5x + 6$       [D]  $x^2 + 5x + 6$

413. When  $-2x^2 + 4x + 2$  is subtracted from  $x^2 + 6x - 4$ , the result is
- [A]  $-x^2 + 10x - 2$       [B]  $3x^2 + 2x - 6$   
[C]  $-3x^2 - 2x + 6$       [D]  $2x^2 - 2x - 6$
414. If  $2x^2 - x + 6$  is subtracted from  $x^2 + 3x - 2$ , the result is
- [A]  $x^2 - 4x + 8$       [B]  $-x^2 + 2x - 8$   
[C]  $x^2 + 2x - 8$       [D]  $-x^2 + 4x - 8$
415. When  $3x^2 - 8x$  is subtracted from  $2x^2 + 3x$ , the difference is
- [A]  $-x^2 - 11x$       [B]  $-x^2 + 11x$   
[C]  $-x^2 - 5x$       [D]  $x^2 - 5x$
416. Subtract  $5x^2 - 7x - 6$  from  $9x^2 + 3x - 4$ .
417. The expression  $(x^2 - 5x - 2) - (-6x^2 - 7x - 3)$  is equivalent to
- [A]  $7x^2 - 12x - 5$       [B]  $7x^2 + 2x - 5$   
[C]  $7x^2 - 2x + 1$       [D]  $7x^2 + 2x + 1$

## ALGEBRA CHAPTER 10-2

418. If  $3x$  is one factor of  $3x^2 - 9x$ , what is the other factor?
- [A]  $x^2 - 6x$       [B]  $x - 3$   
[C]  $x + 3$       [D]  $3x$
419. If one factor of  $56x^4y^3 - 42x^2y^6$  is  $14x^2y^3$ , what is the other factor?
- [A]  $4x^2y - 3xy^2$       [B]  $4x^2 - 3y^3$   
[C]  $4x^2 - 3y^2$       [D]  $4x^2y - 3xy^3$
420. When  $3x^2 - 6x$  is divided by  $3x$ , the result is
- [A]  $x + 2$       [B]  $x - 2$   
[C]  $-2x$       [D]  $2x$

## ALGEBRA CHAPTER 10-3

421. The expression  $(a^2 + b^2)^2$  is equivalent to
- [A]  $a^4 + a^2b^2 + b^4$       [B]  $a^4 + 4a^2b^2 + b^4$   
[C]  $a^4 + b^4$       [D]  $a^4 + 2a^2b^2 + b^4$
422. The expression  $(x - 6)^2$  is equivalent to
- [A]  $x^2 + 36$       [B]  $x^2 - 36$   
[C]  $x^2 + 12x + 36$       [D]  $x^2 - 12x + 36$

## ALGEBRA CHAPTER 10-4

423. Which expression is a factor of  $x^2 + 2x - 15$
- [A]  $(x - 3)$       [B]  $(x + 15)$   
[C]  $(x + 3)$       [D]  $(x - 5)$
424. Which expression is a factor of  $n^2 + 3n - 54$ ?
- [A]  $n + 9$       [B]  $n - 9$   
[C]  $n + 6$       [D]  $n^2 + 9$
425. What are the factors of  $x^2 - 10x - 24$ ?
- [A]  $(x - 4)(x - 6)$       [B]  $(x + 12)(x - 2)$   
[C]  $(x - 4)(x + 6)$       [D]  $(x - 12)(x + 2)$

426. Factor completely:  $3x^2 + 15x - 42$

## ALGEBRA CHAPTER 10-5

427. What is a common factor of  $x^2 - 9$  and  $x^2 - 5x + 6$ ?
- [A]  $x^2$       [B]  $x + 3$   
[C]  $x - 3$       [D]  $x - 2$

428. Expressed in factored form, the binomial  $4a^2 - 9b^2$  is equivalent to  
[A]  $(2a - 9b)(2a + b)$   
[B]  $(2a + 3b)(2a - 3b)$   
[C]  $(4a - 3b)(a + 3b)$   
[D]  $(2a - 3b)(2a - 3b)$
429. One of the factors of  $4x^2 - 9$  is  
[A]  $(x + 3)$  [B]  $(4x - 3)$   
[C]  $(x - 3)$  [D]  $(2x + 3)$
430. Factor completely:  $3x^2 - 27$   
[A]  $3(x + 3)(x - 3)$  [B]  $3(x^2 - 27)$   
[C]  $3(x - 3)^2$  [D]  $(3x + 3)(x - 9)$
431. Written in simplest factored form, the binomial  $2x^2 - 50$  can be expressed as  
[A]  $2(x - 5)(x - 5)$  [B]  $2(x - 5)(x + 5)$   
[C]  $(x - 5)(x + 5)$  [D]  $2x(x - 50)$
432. Factor completely:  $3ax^2 - 27a$
433. Factor completely:  $5n^2 - 80$
434. If  $2ax - 5x = 2$ , then  $x$  is equivalent to  
[A]  $7 - 2a$  [B]  $\frac{2 + 5a}{2a}$   
[C]  $\frac{1}{a - 5}$  [D]  $\frac{2}{2a - 5}$
435. If  $(x - 4)$  is a factor of  $x^2 - x - w = 0$ , then the value of  $w$  is  
[A] -12 [B] 12 [C] -3 [D] 3
436. One root of the equation  $2x^2 - x - 15 = 0$  is  
[A] -3 [B] 3 [C]  $\frac{5}{2}$  [D]  $\frac{3}{2}$
437. The larger root of the equation  $(x + 4)(x - 3) = 0$  is  
[A] 4 [B] -3 [C] 3 [D] -4
438. What is the solution set of the equation  $3x^2 - 34x - 24 = 0$ ?  
[A]  $\{-2, 6\}$  [B]  $\{-6, 2\}$   
[C]  $\left\{-\frac{2}{3}, 12\right\}$  [D]  $\left\{-12, \frac{2}{3}\right\}$
439. The solution set for the equation  $x^2 - 2x - 15 = 0$  is  
[A]  $\{5, 3\}$  [B]  $\{-5, -3\}$   
[C]  $\{5, -3\}$  [D]  $\{-5, 3\}$
440. What is the solution set of  $m^2 - 3m - 10 = 0$ ?  
[A]  $\{3, -10\}$  [B]  $\{3, 10\}$   
[C]  $\{5, -2\}$  [D]  $\{2, -5\}$
441. What is the solution set of the equation  $x^2 - 5x - 24 = 0$ ?  
[A]  $\{-3, -8\}$  [B]  $\{-3, 8\}$   
[C]  $\{3, 8\}$  [D]  $\{3, -8\}$
442. What is the solution set for the equation  $x^2 - 5x + 6 = 0$   
[A]  $\{-2, -3\}$  [B]  $\{6, -1\}$   
[C]  $\{-6, 1\}$  [D]  $\{2, 3\}$
443. What is the solution set of the equation  $x^2 + 11x + 28 = 0$ ?  
[A]  $\{-7, 4\}$  [B]  $\{-7, -4\}$   
[C]  $\{-3, -4\}$  [D]  $\{3, 4\}$

## ALGEBRA CHAPTER 10-6



444. The solution set for the equation  $x^2 - 5x = 6$  is

- [A]  $\{-2,3\}$                       [B]  $\{1,-6\}$   
[C]  $\{2,-3\}$                       [D]  $\{-1,6\}$

445. Solve for  $x$ :  $x^2 + 3x - 40 = 0$

446. Solve for  $x$ :  $x^2 + 3x - 28 = 0$

447. Solve the following system of equations algebraically or graphically for  $x$  and  $y$ :

$$y = x^2 + 2x - 1$$

$$y = 3x + 5$$

For an algebraic solution, show your work here .

For a graphic solution, show your work here.

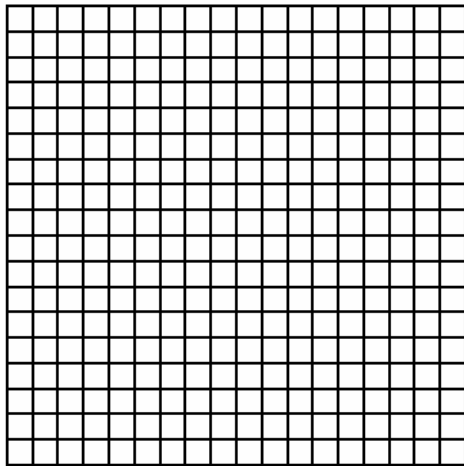

448. Solve the following system of equations algebraically.

$$y = x^2 + 4x - 2$$

$$y = 2x + 1$$

449. The graph of a quadratic equation is shown in the accompanying diagram. The scale on the axes is a unit scale. Write an equation of this graph in standard form.

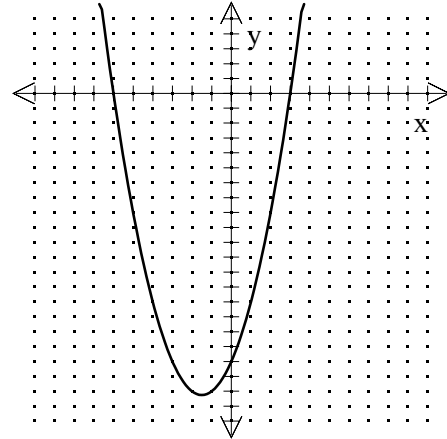

450. Three brothers have ages that are consecutive even integers. The product of the first and third boys' ages is 20 more than twice the second boy's age. Find the age of *each* of the three boys.

451. Find three consecutive odd integers such that the product of the first and the second exceeds the third by 8.

452. A ball is thrown straight up at an initial velocity of 54 feet per second. The height of the ball  $t$  seconds after it is thrown is given by the formula  $h(t) = 54t - 12t^2$ . How many seconds after the ball is thrown will it return to the ground?

- [A] 4.5      [B] 6      [C] 9.2      [D] 4

## ALGEBRA CHAPTER 11-2

453. What is the domain of the function

$$f(x) = \frac{2x^2}{x^2 - 9}?$$

- [A] all real numbers except 3 and -3
- [B] all real numbers except 0
- [C] all real numbers except 3
- [D] all real numbers

454. What is the domain of the function

$$f(x) = \frac{3x^2}{x^2 - 49}?$$

- [A]  $\{x \mid x \in \text{real numbers}, x \neq 0\}$
- [B]  $\{x \mid x \in \text{real numbers}, x \neq \pm 7\}$
- [C]  $\{x \mid x \in \text{real numbers}\}$
- [D]  $\{x \mid x \in \text{real numbers}, x \neq 7\}$

455. If  $f(x) = \frac{1}{\sqrt{2x-4}}$ , the domain of  $f(x)$  is

- [A]  $x < 2$
- [B]  $x = 2$
- [C]  $x > 2$
- [D]  $x \geq 2$

## ALGEBRA CHAPTER 11-3

456. For which value of  $x$  is the expression  $\frac{x-7}{x+2}$  undefined?

- [A] 0
- [B] 7
- [C] -2
- [D] 2

457. For which value of  $x$  is the expression  $\frac{3x-6}{x-4}$  undefined?

- [A] 0
- [B] -4
- [C] 4
- [D] 2

458. If  $x \neq 0$ , the expression  $\frac{x^2+2x}{x}$  is equivalent to

- [A]  $3x$
- [B] 4
- [C]  $x+2$
- [D] 2

459. Which polynomial is the quotient of  $\frac{6x^3+9x^2+3x}{3x}$ ?

- [A]  $2x+3$
- [B]  $6x^2+9x$
- [C]  $2x^2+3x+1$
- [D]  $2x^2+3x$

460. Simplify:  $\frac{9x^2-15xy}{9x^2-25y^2}$

461. Perform the indicated operation and express the result in simplest terms:

$$\frac{x}{x+3} \div \frac{3x}{x^2-9}$$

## ALGEBRA CHAPTER 11-4

462. Which expression is equivalent to  $\frac{a}{x} + \frac{b}{2x}$ ?

- [A]  $\frac{2a+b}{x}$
- [B]  $\frac{2a+b}{2x}$
- [C]  $\frac{a+b}{2x}$
- [D]  $\frac{a+b}{3x}$

463. Expressed as a single fraction, what is

$$\frac{1}{x+1} + \frac{1}{x}, x \neq 0, -1?$$

- [A]  $\frac{2}{2x+1}$
- [B]  $\frac{2x+3}{x^2+x}$
- [C]  $\frac{3}{x^2}$
- [D]  $\frac{2x+1}{x^2+x}$

464. The sum of  $\frac{3}{x} + \frac{2}{5}$ ,  $x \neq 0$ , is

- [A]  $\frac{1}{x}$                       [B]  $\frac{5}{x+5}$   
[C]  $\frac{2x+15}{5x}$                 [D]  $\frac{2x+15}{x+5}$

465. What is the sum of  $\frac{2}{x}$  and  $\frac{x}{2}$ ?

- [A]  $\frac{4+x^2}{2x}$                     [B]  $\frac{4+x}{2x}$   
[C] 1                            [D]  $\frac{2+x}{2x}$

466. The expression  $\frac{y}{x} - \frac{1}{2}$  is equivalent to

- [A]  $\frac{x-2y}{2x}$                       [B]  $\frac{y-1}{x-2}$   
[C]  $\frac{2y-x}{2x}$                       [D]  $\frac{1-y}{2x}$

467. What is the least common denominator of  $\frac{1}{2}$ ,

$\frac{2}{7x}$ , and  $\frac{5}{x}$ ?

- [A]  $9x$     [B]  $14x$     [C]  $2x$     [D]  $14x^2$

## ALGEBRA CHAPTER 11-5

468. Solve for all values of  $x$  that satisfy the

equation  $\frac{x}{x+3} = \frac{5}{x+7}$ .

469. Solve algebraically for  $x$ :  $\frac{1}{x} = \frac{x+1}{6}$

470. If  $\frac{x}{4} - \frac{a}{b} = 0$ ,  $b \neq 0$ , then  $x$  is equal to

- [A]  $\frac{a}{4b}$     [B]  $-\frac{4a}{b}$     [C]  $\frac{4a}{b}$     [D]  $-\frac{a}{4b}$

## ALGEBRA CHAPTER 11-6

471. A certain car comes in three body styles with a choice of two engines, a choice of two transmissions, and a choice of six colors. What is the minimum number of cars a dealer must stock to have one car of every possible combination?

- [A] 36    [B] 72    [C] 13    [D] 42

472. How many different outfits consisting of a hat, a pair of slacks, and a sweater can be made from two hats, three pairs of slacks, and four sweaters?

- [A] 12    [B] 29    [C] 9    [D] 24

473. Juan has three blue shirts, two green shirts, seven red shirts, five pairs of denim pants, and two pairs of khaki pants. How many different outfits consisting of one shirt and one pair of pants are possible?

- [A] 420    [B] 19    [C] 84    [D] 130

474. In a school building, there are 10 doors that can be used to enter the building and 8 stairways to the second floor. How many different routes are there from outside the building to a class on the second floor?

- [A] 80    [B] 10    [C] 18    [D] 1

475. The school cafeteria offers five sandwich choices, four desserts, and three beverages. How many different meals consisting of one sandwich, one dessert, and one beverage can be ordered?

- [A] 1    [B] 60    [C] 3    [D] 12

476. A deli has five types of meat, two types of cheese, and three types of bread. How many different sandwiches, consisting of one type of meat, one type of cheese, and one type of bread, does the deli serve?

- [A] 75    [B] 30    [C] 25    [D] 10

477. When Kimberly bought her new car, she found that there were 72 different ways her car could be equipped. Her choices included four choices of engine and three choices of transmission. If her only other choice was color, how many choices of color did she have?  
[A] 65 [B] 6 [C] 12 [D] 60
478. Megan decides to go out to eat. The menu at the restaurant has four appetizers, three soups, seven entrees, and five desserts. If Megan decides to order an appetizer *or* a soup, and one entree, and two different desserts, how many different choices can she make?
479. Paloma has 3 jackets, 6 scarves, and 4 hats. Determine the number of different outfits consisting of a jacket, a scarf, and a hat that Paloma can wear.
480. Jeremy's bedroom has two doors leading into the hallway. His house has four doors leading to the outside. Using the doorways, in how many different ways can Jeremy leave his room and go outside?  
[A] 4 [B] 5 [C] 6 [D] 8
481. Cole's Ice Cream Stand serves sixteen different flavors of ice cream, three types of syrup, and seven types of sprinkles. If an ice cream sundae consists of one flavor of ice cream, one type of syrup, and one type of sprinkles, how many different ice cream sundaes can Cole serve?  
[A] 3 [B] 336 [C] 10,836 [D] 26
482. The value of  $5!$  is  
[A] 20 [B] 5 [C]  $\frac{1}{5}$  [D] 120
483. The value of  $\frac{7!}{3!}$  is  
[A] 24 [B] 7 [C] 4 [D] 840
484. The expression  ${}_9C_2$  is equivalent to  
[A]  ${}_9P_2$  [B]  ${}_9P_7$  [C]  ${}_9C_7$  [D]  $\frac{9!}{2!}$
485. A locker combination system uses three digits from 0 to 9. How many different three-digit combinations with no digit repeated are possible?  
[A] 720 [B] 1,000 [C] 504 [D] 30
486. How many different 6-letter arrangements can be formed using the letters in the word "**ABSENT**," if each letter is used only once?  
[A] 6 [B] 36 [C] 46,656 [D] 720
487. How many different 4-letter arrangements can be formed using the letters of the word "**JUMP**," if each letter is used only once?  
[A] 24 [B] 12 [C] 16 [D] 4
488. How many different five-digit numbers can be formed from the digits 1, 2, 3, 4, and 5 if each digit is used only once?  
[A] 120 [B] 20 [C] 60 [D] 24
489. All seven-digit telephone numbers in a town begin with 245. How many telephone numbers may be assigned in the town if the last four digits do *not* begin or end in a zero?
490. The telephone company has run out of seven-digit telephone numbers for an area code. To fix this problem, the telephone company will introduce a new area code. Find the number of new seven-digit telephone numbers that will be generated for the new area code if both of the following conditions must be met:  
o The first digit cannot be a zero or a one.  
o The first three digits cannot be the emergency number (911) or the number used for information (411).

491. In Jackson County, Wyoming, license plates are made with two letters ( $A$  through  $Z$ ) followed by three digits (0 through 9). The plates are made according to the following restrictions:
- o the first letter must be  $J$  or  $W$ , and the second letter can be any of the 26 letters in the alphabet
  - o no digit can be repeated
- How many different license plates can be made with these restrictions?
492. A certain state is considering changing the arrangement of letters and numbers on its license plates. The two options the state is considering are:
- Option 1: three letters followed by a four-digit number with repetition of both letters and digits allowed
- Option 2: four letters followed by a three-digit number without repetition of either letters or digits
- [Zero may be chosen as the first digit of the number in either option.]
- Which option will enable the state to issue more license plates? How many *more* different license plates will that option yield?
493. Six members of a school's varsity tennis team will march in a parade. How many different ways can the players be lined up if Angela, the team captain, is always at the front of the line?
494. There were seven students running in a race. How many different arrangements of first, second, and third place are possible?
496. In a game, each player receives 5 cards from a deck of 52 different cards. How many different groupings of cards are possible in this game?
- [A]  $5!$  [B]  $\frac{52!}{5!}$  [C]  ${}_{52}C_5$  [D]  ${}_{52}P_5$
497. How many different three-member teams can be formed from six students?
- [A] 120 [B] 720 [C] 216 [D] 20
498. There are 12 people on a basketball team, and the coach needs to choose 5 to put into a game. How many different possible ways can the coach choose a team of 5 if each person has an equal chance of being selected?
- [A]  ${}_5P_{12}$  [B]  ${}_{12}P_5$  [C]  ${}_{12}C_5$  [D]  ${}_5C_{12}$
499. How many different five-member teams can be made from a group of eight students, if each student has an equal chance of being chosen?
- [A] 56 [B] 6,720 [C] 336 [D] 40
500. Five people have volunteered to work on an awards dinner at Madison High School. How many different committees of four can be formed from the five people?
- [A] 10 [B] 1 [C] 20 [D] 5
501. If there are four teams in a league, how many games will have to be played so that each team plays every other team once?
- [A] 6 [B] 3 [C] 16 [D] 8

## ALGEBRA CHAPTER 11-7

495. How many different three-member teams can be selected from a group of seven students?
- [A] 5,040 [B] 35 [C] 1 [D] 210
502. On a bookshelf, there are five different mystery books and six different biographies. How many different sets of four books can Emilio choose if two of the books must be mystery books and two of the books must be biographies?

503. Alan, Becky, Jesus, and Mariah are four students in the chess club. If two of these students will be selected to represent the school at a national convention, how many combinations of two students are possible?
504. An algebra class of 21 students must send 5 students to meet with the principal. How many different groups of 5 students could be formed from this class?
505. Three roses will be selected for a flower vase. The florist has 1 red rose, 1 white rose, 1 yellow rose, 1 orange rose and 1 pink rose from which to choose.
- a* How many different three rose selections can be formed from the 5 roses?
- b* What is the probability that 3 roses selected at random will contain 1 red rose, 1 white rose, and 1 pink rose?
- c* What is the probability that 3 roses selected at random will *not* contain an orange rose?
506. Paul orders a pizza. Chef Carl randomly chooses two different toppings to put on the pizza from the following: pepperoni, onion, sausage, mushrooms, and anchovies. If Paul will not eat pizza with mushrooms, determine the probability that Paul will *not* eat the pizza Chef Carl has made.
507. Sal has a small bag of candy containing three green candies and two red candies. While waiting for the bus, he ate two candies out of the bag, one after another, without looking. What is the probability that both candies were the same color?
508. Alexi's wallet contains four \$1 bills, three \$5 bills, and one \$10 bill. If Alexi randomly removes two bills without replacement, determine whether the probability that the bills will total \$15 is greater than the probability that the bills will total \$2.