

PHYSICAL SETTING EARTH SCIENCE

Thursday, August 17, 2023 — 8:30 to 11:30 a.m., only

The possession or use of any communications device is strictly prohibited when taking this examination. If you have or use any communications device, no matter how briefly, your examination will be invalidated and no score will be calculated for you.

Use your knowledge of Earth science to answer all questions in this examination. Before you begin this examination, you must be provided with the *2011 Edition Reference Tables for Physical Setting/Earth Science*. You will need these reference tables to answer some of the questions.

You are to answer all questions in all parts of this examination. You may use scrap paper to work out the answers to the questions, but be sure to record your answers on your answer sheet and in your answer booklet. A separate answer sheet for Part A and Part B–1 has been provided to you. Follow the instructions from the proctor for completing the student information on your answer sheet. Record your answers to the Part A and Part B–1 multiple-choice questions on this separate answer sheet. Record your answers for the questions in Part B–2 and Part C in your separate answer booklet. Be sure to fill in the heading on the front of your answer booklet.

All answers in your answer booklet should be written in pen, except for graphs and drawings, which should be done in pencil.

When you have completed the examination, you must sign the declaration printed on your separate answer sheet, indicating that you had no unlawful knowledge of the questions or answers prior to the examination and that you have neither given nor received assistance in answering any of the questions during the examination. Your answer sheet and answer booklet cannot be accepted if you fail to sign this declaration.

Notice ...

A four-function or scientific calculator and a copy of the *2011 Edition Reference Tables for Physical Setting/Earth Science* must be available for you to use while taking this examination.

DO NOT OPEN THIS EXAMINATION BOOKLET UNTIL THE SIGNAL IS GIVEN.

Part A

Answer all questions in this part.

Directions (1–35): For *each* statement or question, choose the word or expression that, of those given, best completes the statement or answers the question. Some questions may require the use of the *2011 Edition Reference Tables for Physical Setting/Earth Science*. Record your answers on your separate answer sheet.

1 Which two factors caused Earth and the other planets to become layered during the formation of our solar system?

- (1) gravity and densities of materials making up the planet
- (2) gravity and percent of water in the planet's composition
- (3) distance from the Moon and densities of materials making up the planet
- (4) distance from the Moon and percent of water in the planet's composition

2 The photograph below shows an object, labeled A, that was observed in the night sky for several weeks.



What is the celestial object labeled A?

- (1) a meteor
- (2) an asteroid
- (3) a galaxy
- (4) a comet

3 The latitudes of the Tropic of Cancer and the Tropic of Capricorn are determined by Earth's

- (1) rotation
- (2) axial tilt
- (3) surface ocean currents
- (4) average surface air temperature

4 The Coriolis effect can best be used to explain the

- (1) cyclic time pattern of ocean tides
- (2) direction of convection currents in the asthenosphere
- (3) deflection of winds to the right in the Northern Hemisphere
- (4) movement of air in a straight path from low pressure to high pressure

5 What is Earth's approximate rate of revolution?

- (1) 1°/hour
- (2) 1°/day
- (3) 15°/hour
- (4) 15°/day

6 At a location in the Northern Hemisphere, a camera was placed outside at night with the lens pointing at a group of stars. The shutter was left open for a few hours, resulting in the image of star trails shown below.

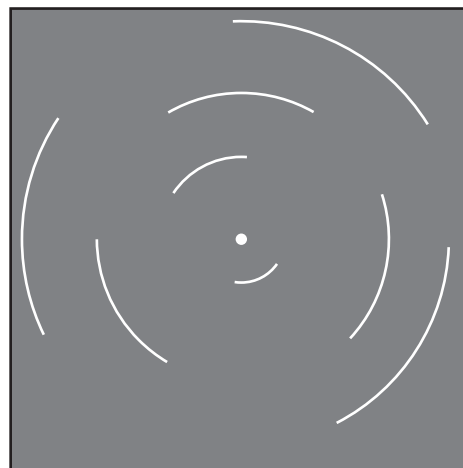

The star at the center of the image did not leave a trail because the star is

- (1) too far away to observe its movement
- (2) too massive to move in space
- (3) not luminous enough to leave a trail
- (4) centered over Earth's axis

7 Which table best lists the differences between a terrestrial planet and a Jovian planet in our solar system?

(1)

Terrestrial Planet	Jovian Planet
mainly rocky in composition	mainly gaseous in composition
small in size	large in size

(2)

Terrestrial Planet	Jovian Planet
mainly gaseous in composition	mainly rocky in composition
small in size	large in size

(3)

Terrestrial Planet	Jovian Planet
mainly rocky in composition	mainly gaseous in composition
large in size	small in size

(4)

Terrestrial Planet	Jovian Planet
mainly gaseous in composition	mainly rocky in composition
large in size	small in size

8 The names and appearances of four Moon phases viewed by an observer in New York State in June are shown below.

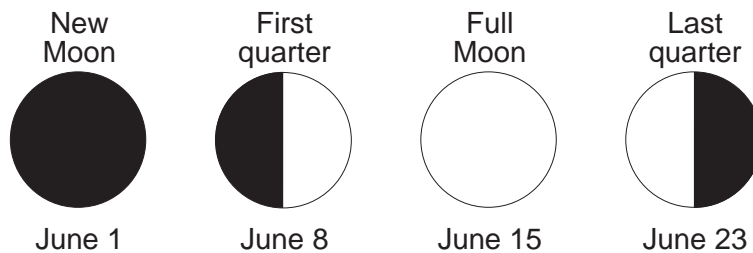

Which diagram best represents the Moon's appearance on June 3?

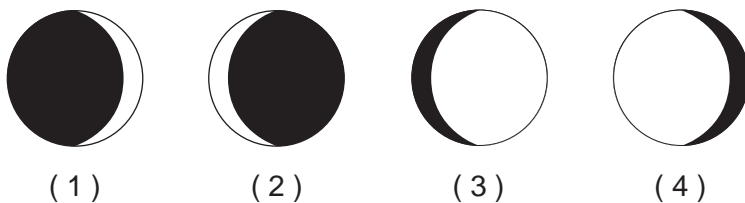

9 Which graph most accurately represents the approximate percentage of Earth's surface covered by the hydrosphere?

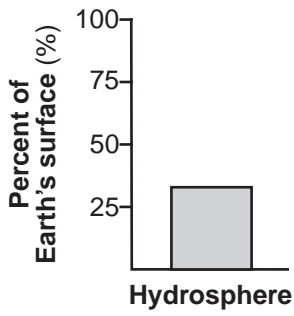

(1)

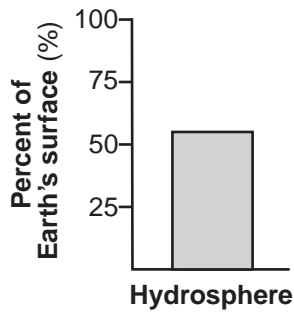

(2)

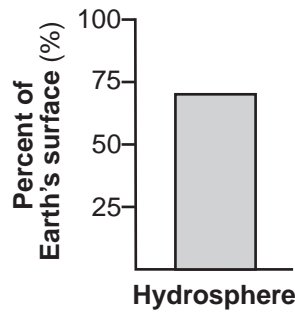

(3)

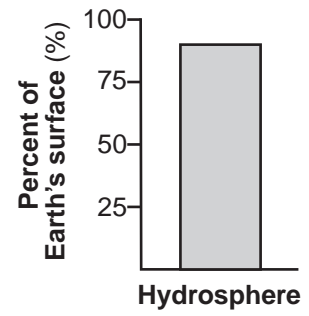

(4)

10 Which diagram shows the correct position of Polaris in the night sky as seen by an observer at Watertown, NY?

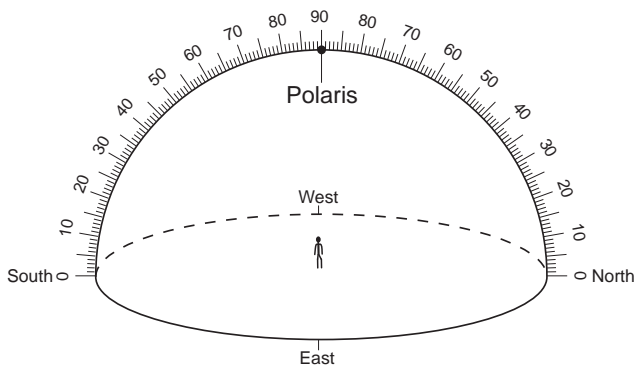

(1)

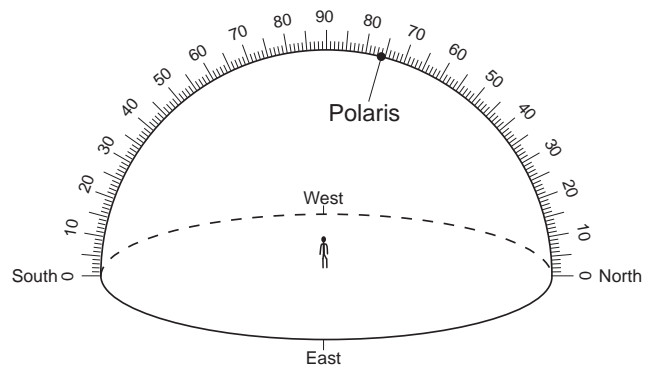

(3)

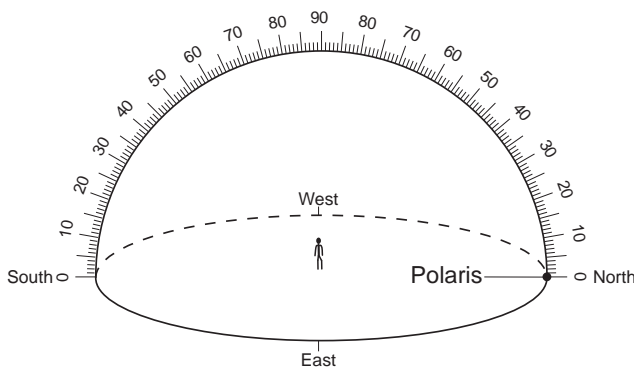

(2)

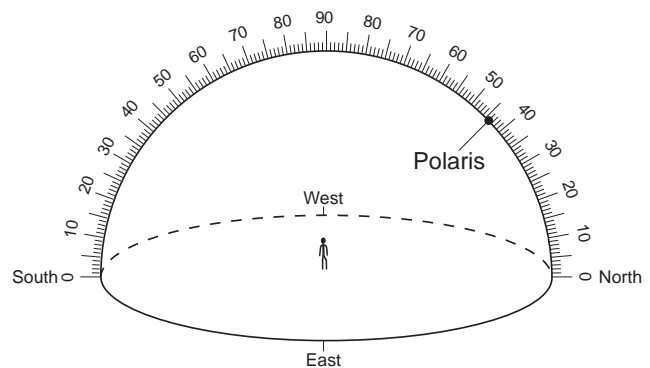

(4)

11 Which process transports groundwater upward through the soil to the surface, where it quickly evaporates during a dry season?

- (1) capillarity
- (2) convection

- (3) infiltration
- (4) saturation

12 The diagram below represents four cylinders of particles, labeled 1 through 4. Cylinders 1 through 3 each contain equal volumes of round particles of uniform size. Cylinder 4 contains round mixed-size particles. Sizes of particles are indicated for each cylinder.

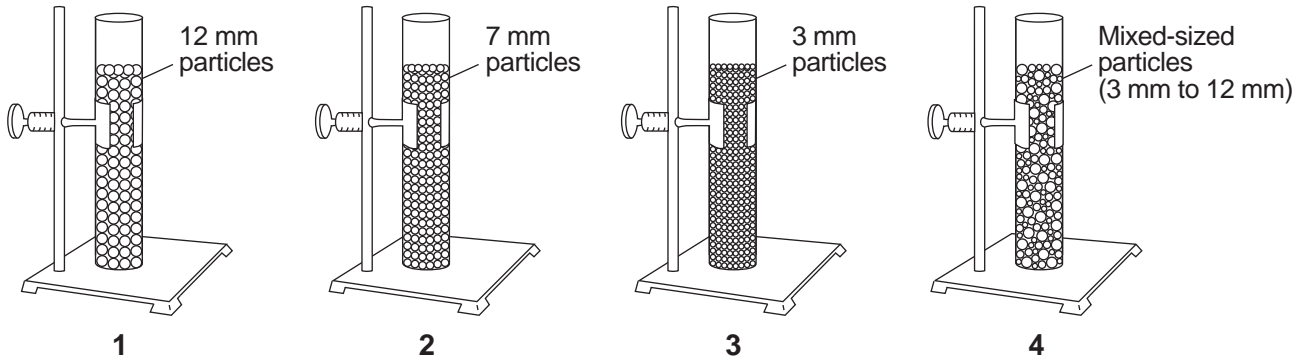

(Not drawn to scale)

Which cylinder contains the particles with the *lowest* porosity?

- (1) 1
- (2) 2
- (3) 3
- (4) 4

13 Which factor is responsible for the circulation of convection currents occurring in the hydrosphere, troposphere, and mantle?

- (1) radioactive decay
- (2) solar radiation
- (3) density differences
- (4) planetary winds

14 The arrows on the two maps below show how the monsoon winds blow over India during the summer and winter seasons.

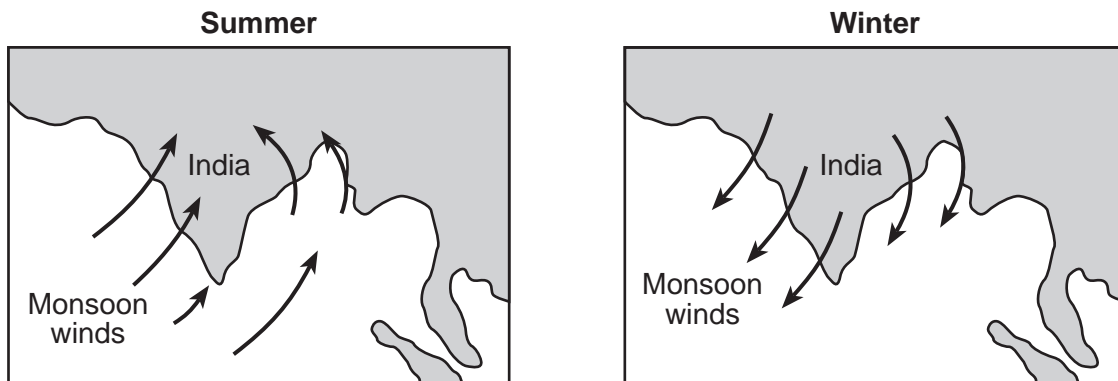

Compared to the amount of rainfall that India receives during the summer monsoon season, the amount of rainfall that India receives during the winter monsoon season is

- (1) less because winds blow from the water to the land
- (2) less because winds blow from the land to the water
- (3) more because winds blow from the water to the land
- (4) more because winds blow from the land to the water

Base your answers to questions 15 and 16 on the map below and on your knowledge of Earth science. The map shows the location of the polar front jet stream during winter. This winter weather pattern brings extremely cold air from the far north into the United States.



15 Which map shows the type of air mass and the direction of polar front jet stream flow associated with this winter weather pattern?

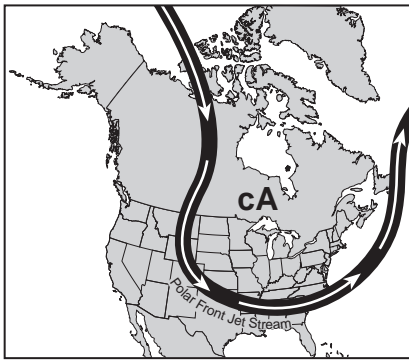

(1)



(3)

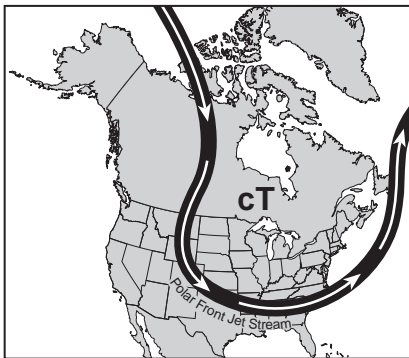

(2)

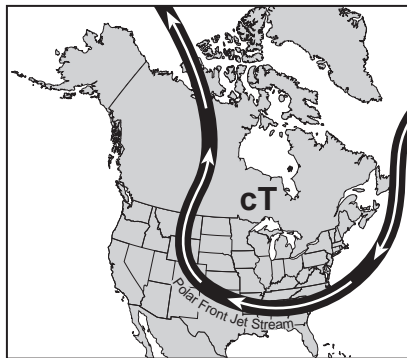

(4)

16 In which atmospheric temperature zone is the polar front jet stream located?

- (1) thermosphere
- (2) mesosphere
- (3) stratosphere
- (4) troposphere

17 Which diagram correctly matches the weather front symbol with its atmospheric cross section?

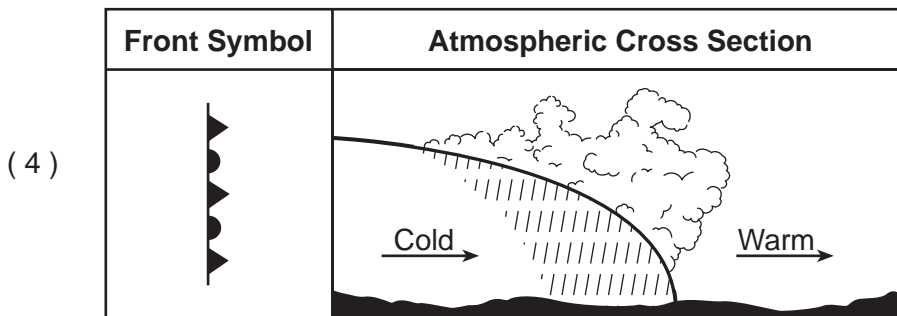
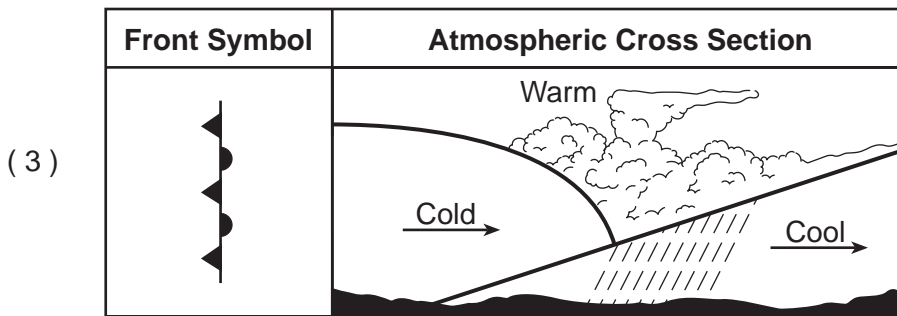
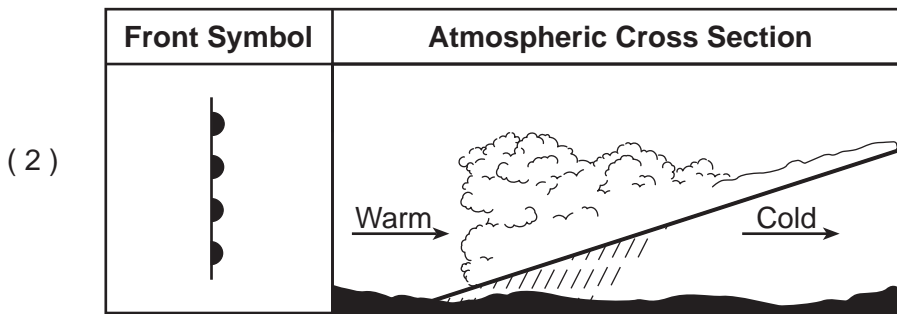
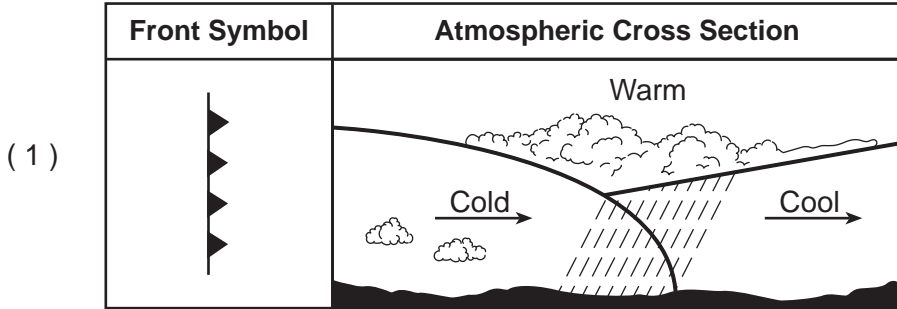

18 If the Tug Hill Plateau region of New York State is experiencing lake-effect snow, winds are most likely blowing in which direction?

- (1) north to south (3) east to west
 (2) south to north (4) west to east

19 Which set of psychrometer measurements was recorded when the dewpoint was 4°C?

- (1) dry bulb, 4°C; wet bulb, 1°C
 (2) dry bulb, 14°C; wet bulb, 9°C
 (3) dry bulb, 20°C; wet bulb, 16°C
 (4) dry bulb, 28°C; wet bulb, 13°C

20 Compared to the summer and winter temperatures at low elevations, higher elevations at the same latitude have

- (1) warmer summers and warmer winters
 (2) warmer summers and cooler winters
 (3) cooler summers and cooler winters
 (4) cooler summers and warmer winters

21 During which geologic period did humans first appear on Earth?

- (1) Quaternary (3) Triassic
 (2) Paleogene (4) Permian

22 The graph below shows the radioactive decay of potassium-40.

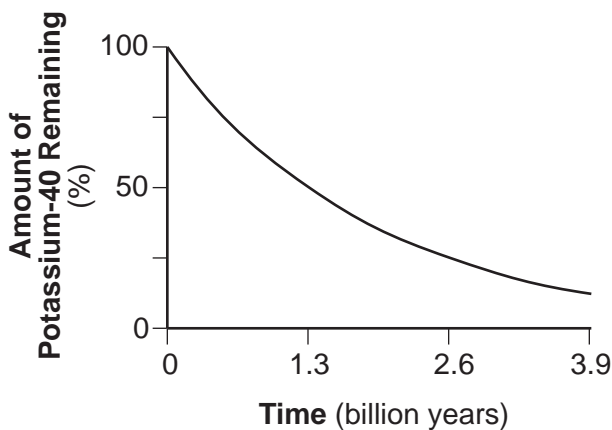

Approximately what percentage of potassium-40 remains in the 1.0 billion-year-old bedrock of the Hudson Highlands landscape region of New York State?

- (1) 10% (3) 60%
 (2) 25% (4) 75%

23 The surface bedrock at Old Forge, New York, is mostly

- (1) flat-lying, sedimentary rock formed during the Grenville Orogeny
 (2) flat-lying, sedimentary rock formed during the Acadian Orogeny
 (3) intensely metamorphosed rock formed during the Grenville Orogeny
 (4) intensely metamorphosed rock formed during the Acadian Orogeny

24 Which agent of erosion produced many of the large parallel grooves and scratches seen in surface bedrock across New York State?

- (1) mass movement (3) running water
 (2) wind (4) glaciers

25 The diagram below represents rock A changing into rock B.

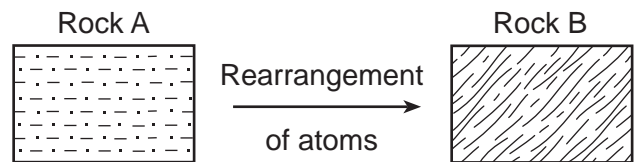

Which process causes rock A to change into rock B?

- (1) melting (3) precipitation
 (2) solidification (4) metamorphism

26 Which mineral is usually present in pegmatite, phyllite, and siltstone?

- (1) quartz (3) olivine
 (2) garnet (4) pyroxene

27 The table below shows the hardness of some common items.

Item	Hardness
fingernail	2.5
penny coin	3
iron nail	4.5
steel file	6

Which mineral could be scratched by an iron nail, but not by a penny coin?

- (1) quartz (3) dolomite
 (2) halite (4) amphibole

28 Which graph shows the general relationship between an increase in urbanization in an area and the average annual air temperature for that area?

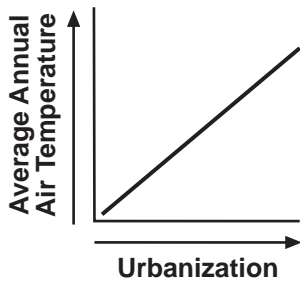

(1)

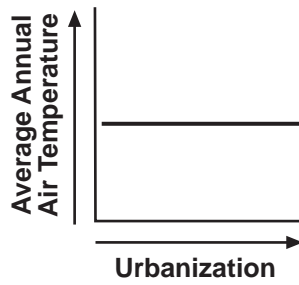

(2)

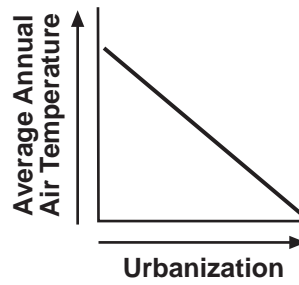

(3)

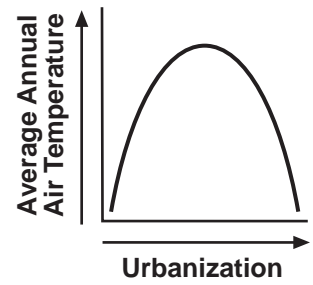

(4)

29 The cross section below represents sedimentary rock layers A, B, and C. An igneous intrusion is labeled D. Line E represents a fault. Overturning has *not* occurred.

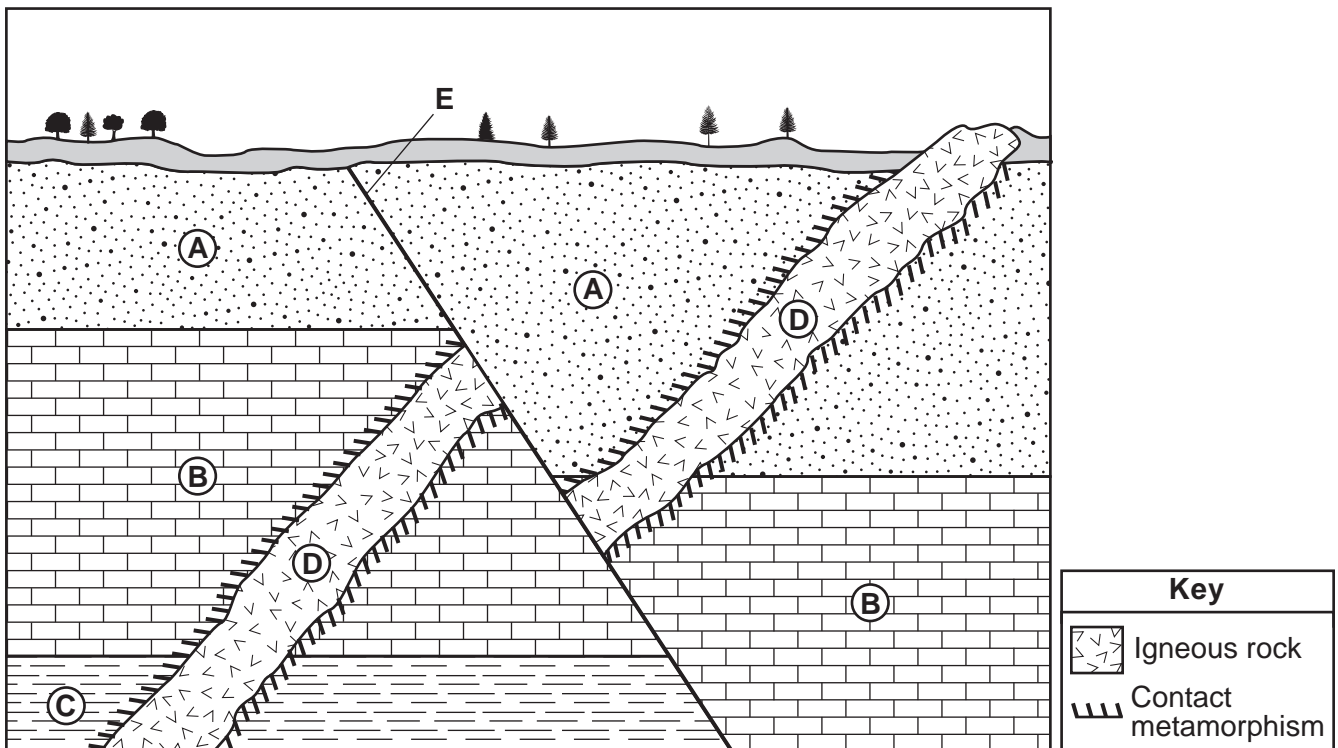

Which events occurred after the formation of rock layer A?

- (1) igneous intrusion *D* and faulting at *E*
- (2) deposition of sediments in rock layers *B* and *C*
- (3) faulting at *E* and deposition of sediments in rock layer *C*
- (4) formation of sedimentary rock layer *B* and igneous intrusion *D*

30 The diagram below represents magnetic patterns of normal and reversed polarity of ocean crust on the west side of a mid-ocean ridge. Letters *A*, *B*, *C*, *D*, and *E* represent locations on the seafloor on the east side of the mid-ocean ridge.

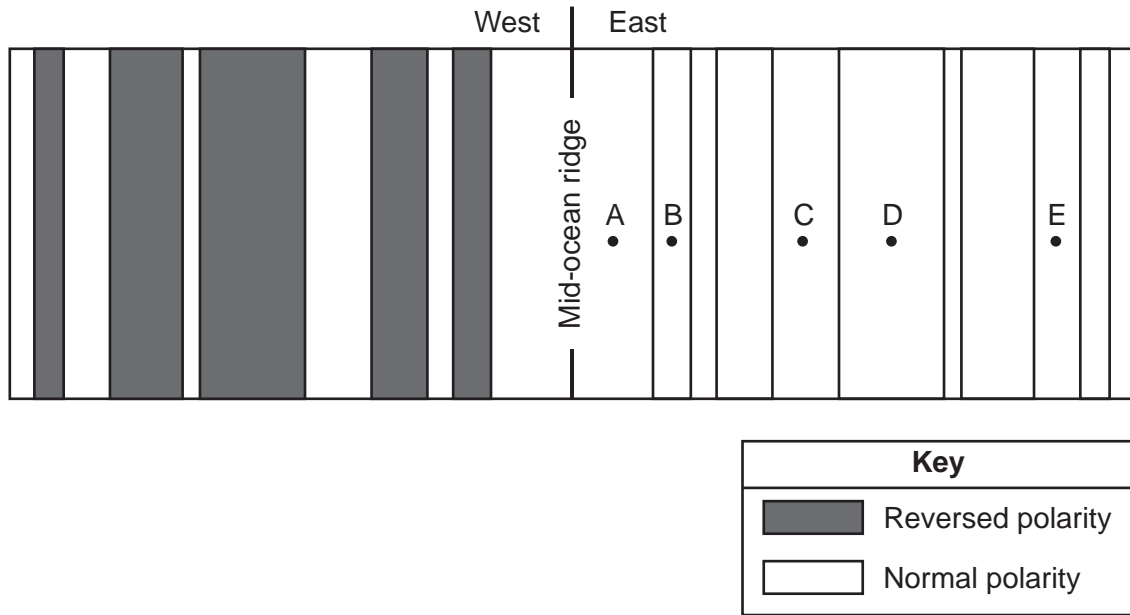

Which two locations on the east side of the mid-ocean ridge represent areas of reversed magnetic polarity?

- (1) *A* and *B*
- (2) *B* and *D*
- (3) *C* and *D*
- (4) *E* and *A*

31 Letters *A* through *D* on the block diagram below represent four features resulting from glaciers.

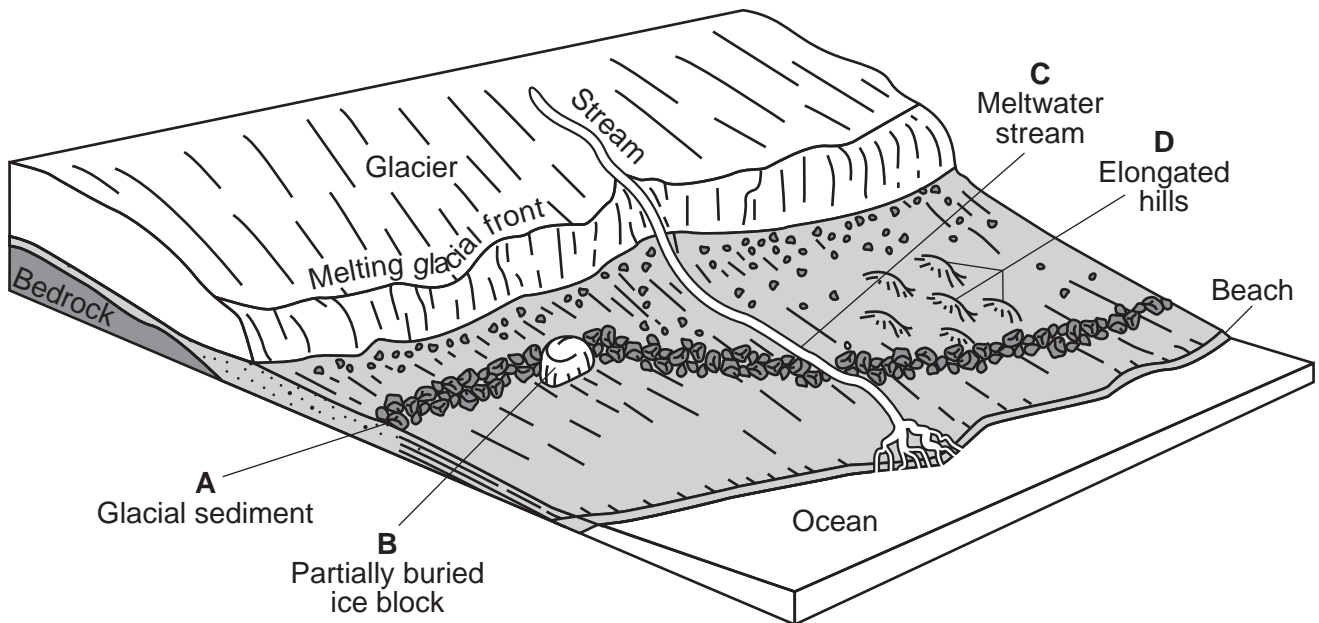

(Not drawn to scale)

Which feature will later form a kettle lake?

- (1) *A*
- (2) *B*
- (3) *C*
- (4) *D*

32 A seismic station is located 2000 kilometers from the epicenter of an earthquake. Which seismogram indicates the correct time difference between the arrival of the first *P*-wave and the first *S*-wave at this station?

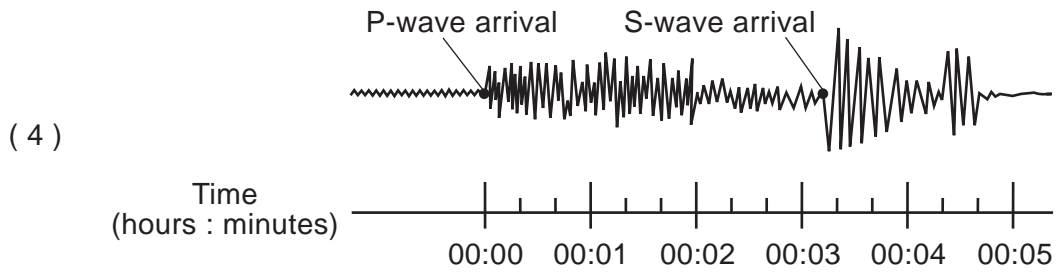
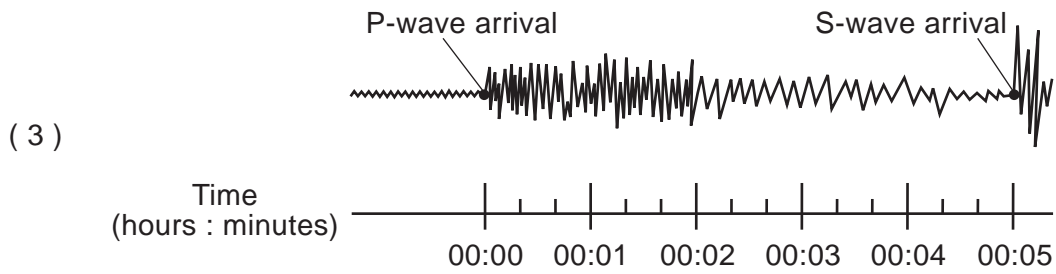
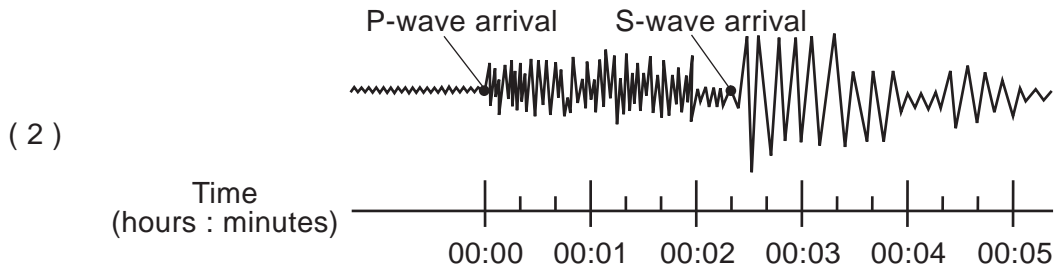
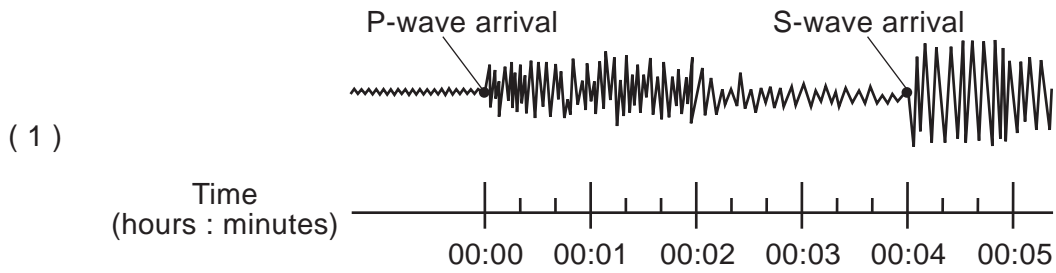

33 The topographic map below shows the path of a river. Points *A* through *E* are locations in the river.

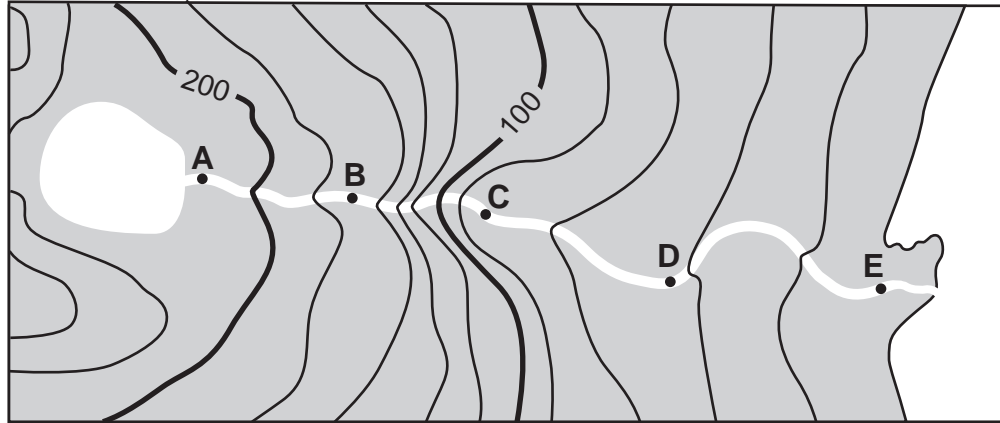

Between which two points is the river flowing the fastest?

- (1) *A* and *B*
- (2) *B* and *C*
- (3) *C* and *D*
- (4) *D* and *E*

34 The diagrams below represent landscapes in regions *A* and *B*.

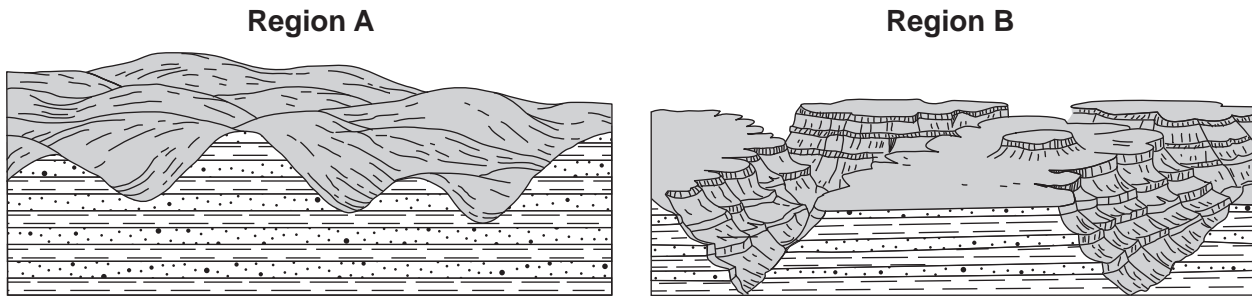

Which chart best summarizes the landscape type and climate of regions *A* and *B*?

	Region A	Region B
Landscape Type	mountain	mountain
Climate	humid	arid

(1)

	Region A	Region B
Landscape Type	plateau	plateau
Climate	humid	arid

(3)

	Region A	Region B
Landscape Type	mountain	mountain
Climate	arid	humid

(2)

	Region A	Region B
Landscape Type	plateau	plateau
Climate	arid	humid

(4)

35 The map below shows a coastal landscape feature, labeled X, that resulted from wave action and offshore currents parallel to the coastline.

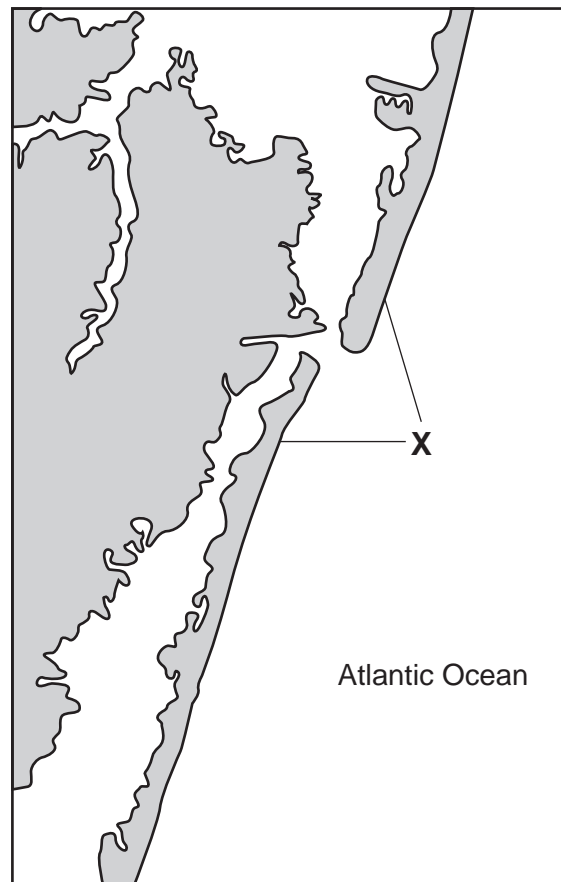

Which landscape feature is represented by X?

- (1) moraines
 - (2) drumlins
 - (3) barrier islands
 - (4) sand dunes
-

Part B-1

Answer all questions in this part.

Directions (36–50): For each statement or question, choose the word or expression that, of those given, best completes the statement or answers the question. Some questions may require the use of the 2011 Edition Reference Tables for Physical Setting/Earth Science. Record your answers on your separate answer sheet.

Base your answers to questions 36 and 37 on the passage below and on your knowledge of Earth science.

Hurricane Sandy

Hurricane Sandy was one of the most severe hurricanes to affect the northeastern United States in many years. On October 29, 2012, this storm made landfall in New Jersey. It produced a 14-foot storm surge, which is a rise in the level of ocean water along a coast caused by strong winds and low air pressure. The Moon also enhanced the effects of this storm surge, since the Moon was in full phase at the time Hurricane Sandy made landfall. During a full Moon, above-normal high tides occur on Earth.

- 36 What was the surface wind circulation pattern around the center of Hurricane Sandy?
- (1) counterclockwise and outward (3) clockwise and outward
(2) counterclockwise and inward (4) clockwise and inward
- 37 Which air temperature and moisture characteristics are associated with the source region over which Hurricane Sandy formed?
- (1) cool and dry (3) warm and dry
(2) cool and moist (4) warm and moist
-

Base your answers to questions 38 and 39 on the diagram below and on your knowledge of Earth science. The diagram represents a model of a portion of our solar system.

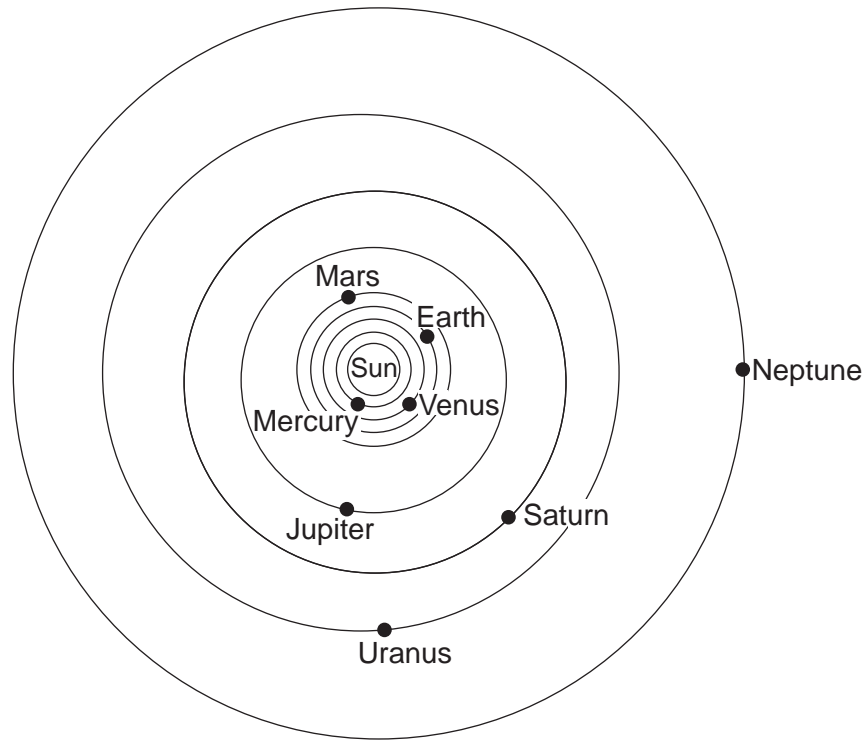

(Not drawn to scale)

38 In our solar system, the orbits of the planets are best described as

- (1) elliptical with the Sun at one focus
- (2) elliptical with Earth at one focus
- (3) circular with the Sun at one focus
- (4) circular with Earth at one focus

39 Which planet takes approximately twice as long as Earth to complete one revolution around the Sun?

- (1) Venus
- (2) Mars
- (3) Jupiter
- (4) Saturn

Base your answers to questions 40 and 41 on the diagram below and on your knowledge of Earth science. The diagram of Earth shows the longitude lines that are used to determine time zones.

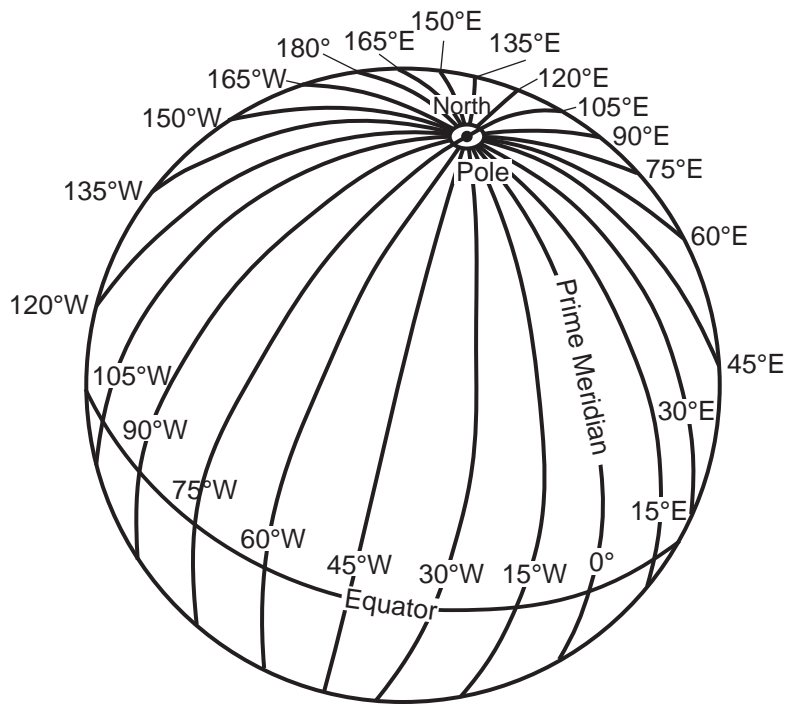

40 Which longitude line passes through New York State?

- | | |
|-----------|-----------|
| (1) 45° W | (3) 75° W |
| (2) 45° E | (4) 75° E |

41 What is the time at 30° W when it is 7:00 a.m. at 30° E?

- | | |
|---------------|----------------|
| (1) 1:00 p.m. | (3) 3:00 a.m. |
| (2) 7:00 p.m. | (4) 11:00 a.m. |
-

Base your answers to questions 42 through 45 on the cross section below and on your knowledge of Earth science. Letters *A* through *E* represent rock units. Letter *F* represents a geologic feature. Some layers contain index fossils.

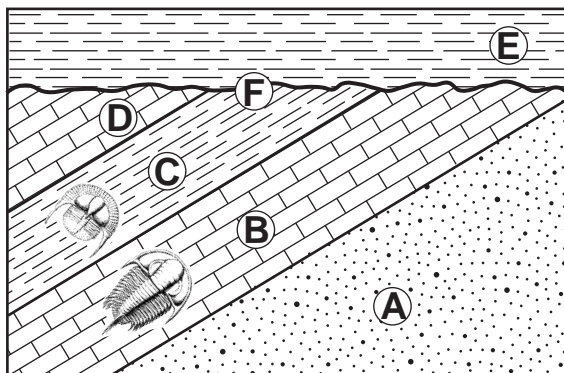

- 42 Which geologic principle could be used to support the inference that rock layers *A* through *D* experienced crustal movement?
- | | |
|--------------------------------|--------------------------|
| (1) original horizontality | (3) superposition |
| (2) crosscutting relationships | (4) contact metamorphism |
- 43 During the Ordovician Period when layer *C* was forming, most of the United States was inferred to be located
- | | |
|-----------------------------------|-----------------------|
| (1) slightly north of the equator | (3) at the North Pole |
| (2) slightly south of the equator | (4) at the South Pole |
- 44 The geologic feature represented by letter *F* is most likely a
- | | |
|---------------------------------|-----------------------------|
| (1) buried erosional surface | (3) meteoritic debris layer |
| (2) contact metamorphic surface | (4) volcanic ash layer |
- 45 Carbon-14 was *not* used to date the trilobite fossils represented in the cross section because these trilobites
- | | |
|---------------------------------|------------------------|
| (1) were never living organisms | (3) lived too long ago |
| (2) were buried too deep | (4) became extinct |
-

Base your answers to questions 46 and 47 on the block diagram below and on your knowledge of Earth science. The diagram represents the water cycle. Letters *A* through *F* represent water cycle processes. The water table has been labeled.

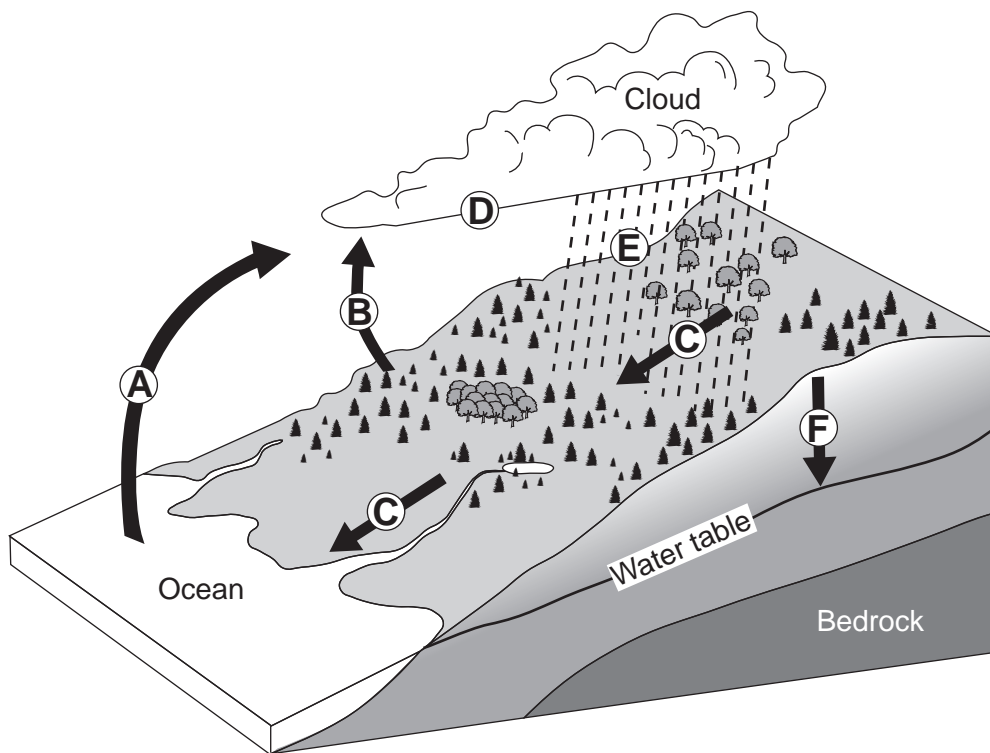

46 Which water cycle process releases 2260 joules of heat energy per gram of water?

- (1) *A*
- (2) *E*
- (3) *F*
- (4) *D*

47 Which diagram would most likely represent the height of the water table if processes *E* and *F* increased?

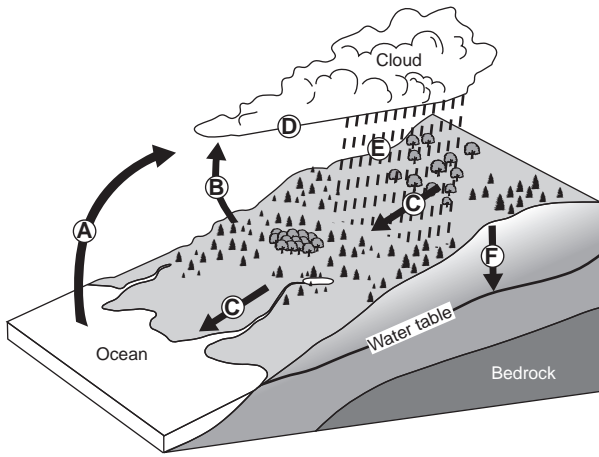

(1)

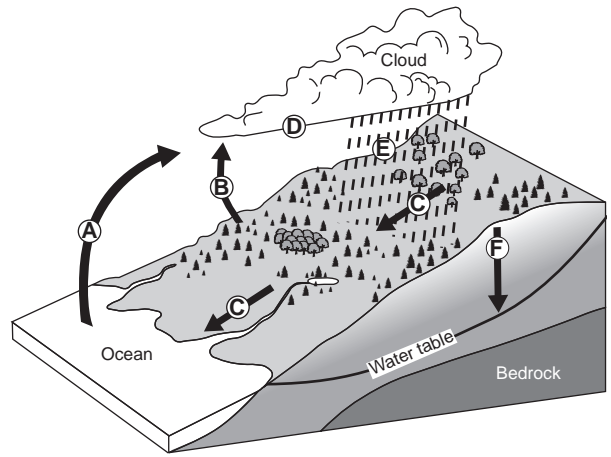

(3)

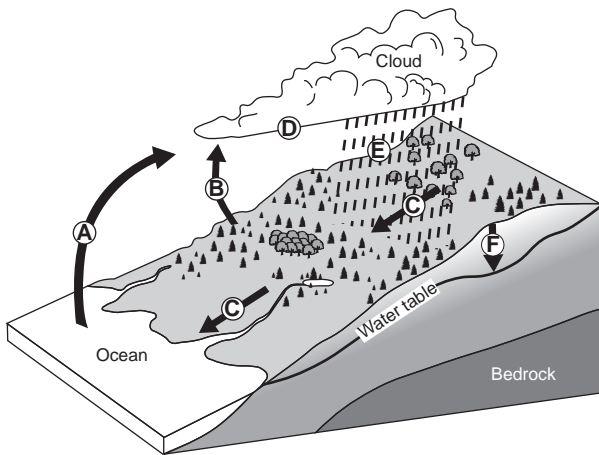

(2)

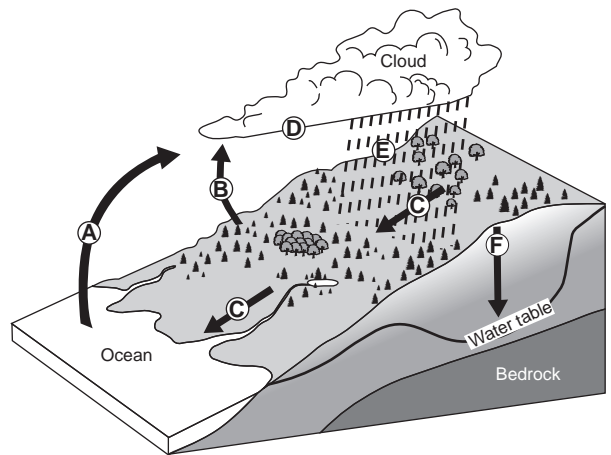

(4)

Base your answers to questions 48 through 50 on the diagram below and on your knowledge of Earth science. The diagram represents insolation received on four Earth land surfaces at locations A, B, C, and D.

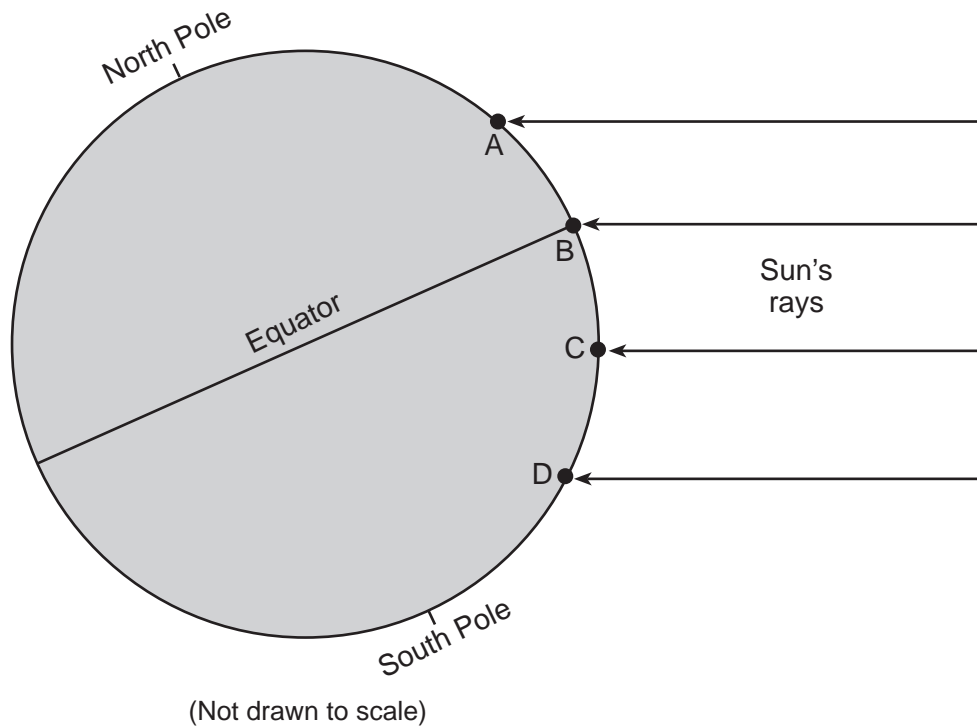

48 Which location is receiving direct rays from the Sun?

- (1) A
- (2) B
- (3) C
- (4) D

49 Equal areas of which type of land surface usually absorb the most insolation and reflect the *least* insolation?

- (1) light-colored and smooth
- (2) light-colored and rough
- (3) dark-colored and smooth
- (4) dark-colored and rough

50 Most of the energy radiated by these land surfaces into space is in the form of

- (1) gamma rays
 - (2) infrared
 - (3) ultraviolet
 - (4) visible light
-

Part B–2

Answer all questions in this part.

Directions (51–65): Record your answers in the spaces provided in your answer booklet. Some questions may require the use of the *2011 Edition Reference Tables for Physical Setting/Earth Science*.

Base your answers to questions 51 through 53 on the passage and the data table below and on your knowledge of Earth science. The data table shows the percentage of quarries in New York State that mine specific types of bedrock to produce crushed stone. A quarry is an area where rock material is removed.

Crushed Stone in New York State

Crushed stone is any bedrock that has been broken into smaller, irregularly shaped fragments. The fragment sizes can range from silt to boulders. The smallest sizes could be used to make concrete and cement while the largest could be used to line a river bank to prevent stream erosion. Although some crushed stone is used in agriculture, most is used in the building and construction industry. Shale, a common rock found in New York State, is rarely mined because it tends to weather too easily to be used as a construction material.

Crushed Stone Production in New York State

Type of Bedrock Mined	Percentage of Quarries (%)
dolostone	14
granite and gneiss	6
limestone	46
sandstone	11
slate and marble	4
all others	19

- 51 Explain why shale is rarely used in the building and construction industry. [1]
- 52 In the building and construction industry, rock sold as granite might actually be gneiss. Identify *one* observable property of gneiss that could be used to distinguish it from granite. [1]
- 53 Identify *one* mineral found in crushed sandstone that is used to make glass in the building and construction industry. [1]
-

Base your answers to questions 54 through 58 on the graph below and on your knowledge of Earth science. The graph shows the predicted distance of five nearby stars in our galaxy in relation to our Sun over the next 60,000 years (y). Distance is represented in light-years (ly) from the Sun. One light-year is the distance light travels in one year.

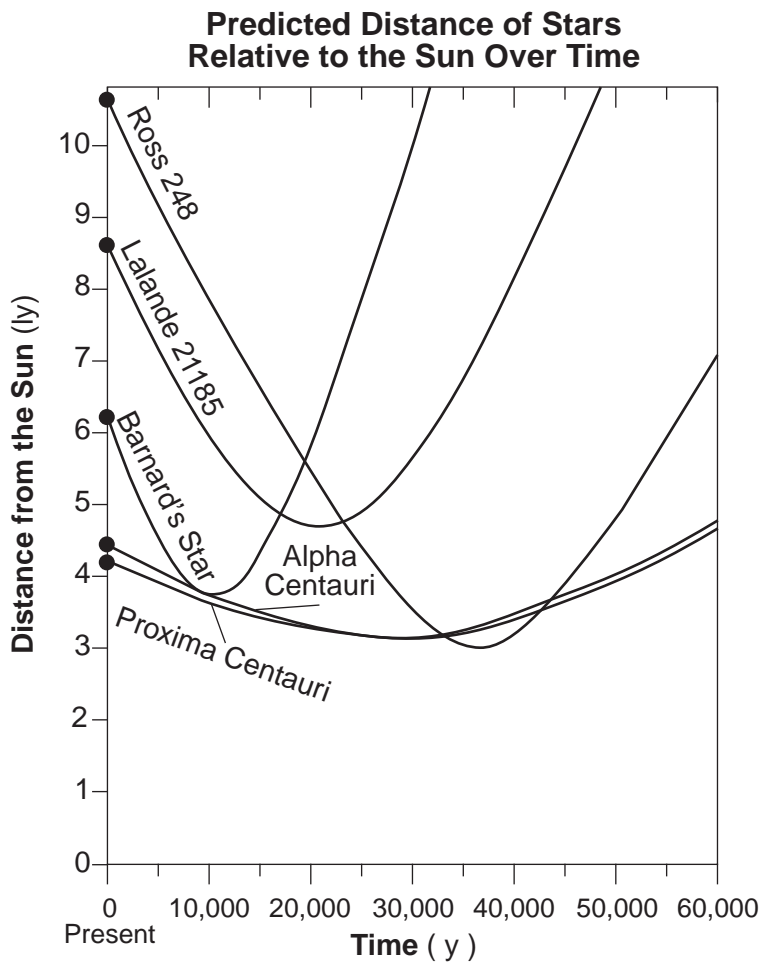

- 54 Determine the approximate present-day distance, in light-years, from the Sun to Lalande 21185. [1]
- 55 Identify the star that will show a redshift in its wavelengths of light as viewed from Earth 15,000 years from the present. [1]
- 56 At present, Proxima Centauri is the closest star to our Sun. However, Alpha Centauri is more easily visible in the night sky. *In your answer booklet*, circle the relative luminosity and relative mass of Alpha Centauri compared with the luminosity and mass of Proxima Centauri. [1]
- 57 State the name of the galaxy in which all of these stars are located. [1]
- 58 Identify the nuclear process that produces most of the energy released from all of these stars. [1]
-

Base your answers to questions 59 and 60 on the station model below and on your knowledge of Earth science. The station model indicates weather conditions at Albany, New York.

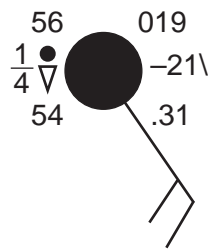

- 59 In the table *in your answer booklet*, identify the numerical value of the data on the station model measured by each weather instrument given. Include units with your answer. [1]
- 60 Based on data from the station model, explain how a scientist could infer that there was a high relative humidity in Albany. [1]
-

Base your answers to questions 61 through 65 on the passage and the map of Alaska below, on the partial isoline map in your answer booklet, and on your knowledge of Earth science. The map of Alaska shows the region from where the isoline map is taken. The isoline map shows the uplift (increase in elevation), in millimeters per year (mm/y), that has occurred for an area in southeastern Alaska. Some isolines have been drawn on the map. Letter A represents a surface location.

Alaskan Rebound

The fastest measured rates of uplift on Earth today are in southeast Alaska. Scientists first hypothesized that the cause of this uplift may have been due to tectonic forces, since this region of Alaska is located on a plate boundary where mountain building occurred. Scientists now hypothesize there is another factor causing the uplift of this region. They determined that, during the last ice age, the weight of mountain glaciers caused Earth's lithosphere to sink lower into the plastic mantle. As atmospheric greenhouse gases increased, the climate changed, causing these glaciers to melt. The lost weight of glacial ice on the lithosphere allowed the crust to rebound and float higher on the plastic mantle below, thus increasing land surface elevations. This phenomenon is called glacial rebound and accounts for the continued uplift rates seen on the rebound map on your answer sheet.

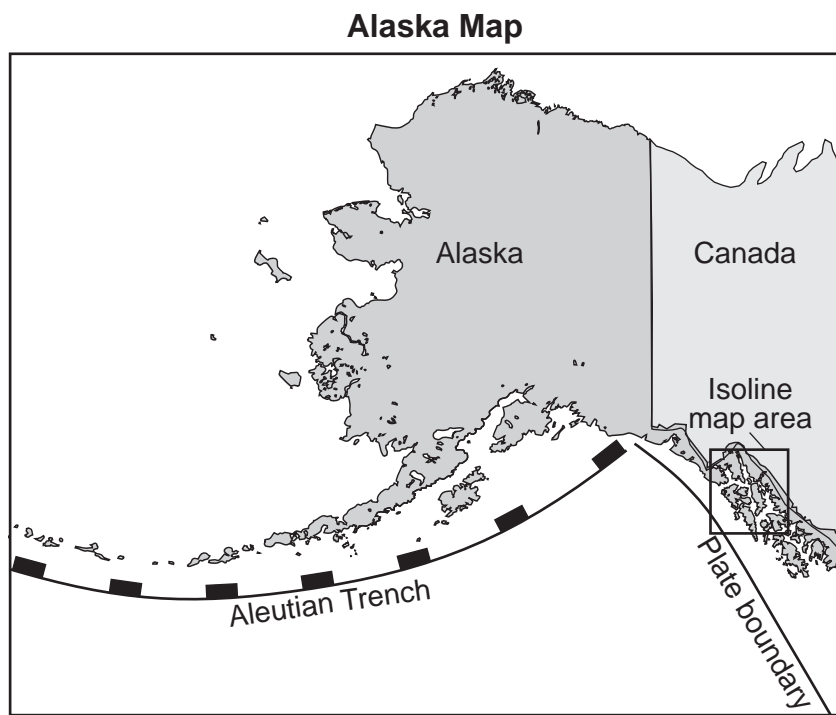

- 61 On the map *in your answer booklet*, draw the 8 mm/y and the 12 mm/y isolines. Extend the isolines to the edge of the map or the edge of the land area. [1]
- 62 The greatest rate of uplift occurred around location A. State *one* possible value, in millimeters/year (mm/y), for location A. [1]
- 63 Identify the name of the plastic mantle layer into which the lithosphere sank due to the weight of the mountain glaciers. [1]

- 64 Identify the names of the *two* tectonic plates that are on either side of the two plate boundaries that are located within the area shown on the Alaska map. [1]
- 65 Identify *two* major greenhouse gases that contribute to climate change and the melting of these Alaskan glaciers. [1]
-

Part C

Answer all questions in this part.

Directions (66–85): Record your answers in the spaces provided in your answer booklet. Some questions may require the use of the *2011 Edition Reference Tables for Physical Setting/Earth Science*.

Base your answers to questions 66 through 69 on the diagram in your answer booklet and on your knowledge of Earth science. The diagram represents three apparent paths of the Sun, labeled A, B, and C, on the first day of each season, as seen by an observer at Binghamton, New York. The Sun's position on path B indicates a specific time of day. Compass directions are indicated along the horizon.

- 66 On the diagram *in your answer booklet*, draw the path of the Sun for November 5. The line representing the Sun's path must begin and end on the horizon. [1]
- 67 Describe how the length of the observer's shadow changes from sunrise to sunset as the Sun appears to travel along path A. [1]
- 68 Identify the time of day indicated by the Sun's position on path B. Indicate a.m. or p.m. in your response. [1]
- 69 *In your answer booklet*, circle the relative intensity of insolation and the relative duration of insolation of the Sun for path C compared to the intensity and duration of insolation of the Sun for path B. [1]
-

Base your answers to questions 70 through 72 on the diagram below and on your knowledge of Earth science. The diagram represents a specific New York State index fossil that is a member of a group of extinct marine animals called eurypterids.

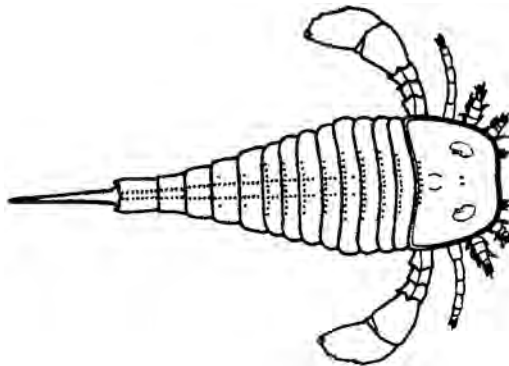

- 70 Identify the geologic period of the bedrock in which this specific New York State index fossil can be found. [1]
- 71 Describe *one* characteristic necessary for this fossil to be classified as an index fossil. [1]
- 72 Infer the past environment that existed at a New York State location where eurypterid fossils have been discovered in the bedrock. [1]
-

Base your answers to questions 73 through 75 on the passage below and on your knowledge of Earth science.

A Geologist's Tour of New York City

When taking a tour of New York City, one can find many geologic points of interest at locations such as Federal Plaza, Wall Street, Foley Square, and Central Park.

Federal Plaza: These buildings contain granite from Avalon, a small continent that was once attached to our east coast when Africa, Europe, and North America pulled apart.

Wall Street: Some buildings contain stone that comes from Morocco in North Africa and contains coral fossils. The same 370-million-year-old coral fossils are also found in some New York State surface bedrock.

Foley Square: A building here is made of limestone that came from Indiana, a region that was a sea floor during the Pennsylvanian Period.

Central Park: The exposed bedrock is schist, and is what remains of an ancient mountain that stood 15,000 feet high. This mountain formed from ocean-bottom mud that was heated, squeezed, and folded upward under pressure.

- 73 *In your answer booklet*, circle either felsic or mafic to indicate the composition of the rock at Federal Plaza and list *two* minerals likely to be found in this rock. [1]
- 74 Identify the New York State landscape region where the surface bedrock most likely contains the same coral fossils as the ones found in Morocco. [1]
- 75 Explain how the 15,000-foot-high ancient mountain was reduced to small hills in today's Central Park. [1]
-

Base your answers to questions 76 through 79 on the map below and on your knowledge of Earth science. The map shows a portion of Earth's Tectonic Plates map from the *2011 Edition Reference Tables for Physical Setting/Earth Science*. The arrows represent relative crustal plate movement. Letters A, B, C, D, E, F, G, and H represent locations on Earth's surface.

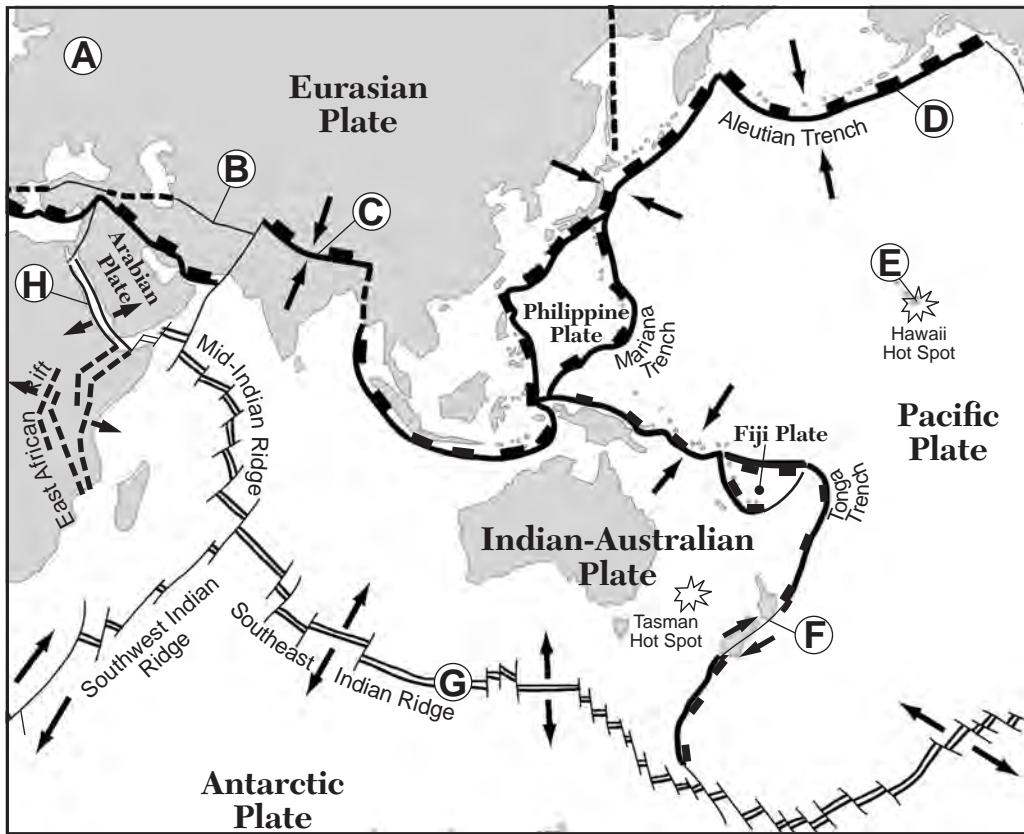

- 76 Identify the *two* letters that indicate locations on transform plate boundaries. [1]
- 77 Explain why earthquakes are more likely to occur near location *H* than near location *A*. [1]
- 78 Scientists infer that the magma that formed the hot spot at location *E* originates at the boundary between the stiffer mantle and the outer core. Determine the depth, in kilometers, below Earth's surface where the boundary between the stiffer mantle and the outer core is located. [1]
- 79 State the name and the density of the igneous rock found at the surface of the Pacific Ocean crust. [1]
-

Base your answers to questions 80 through 82 on the map in your answer booklet and on your knowledge of Earth science. The map shows a stream and its tributary. Letters *A* and *B* are locations in the stream. The arrows indicate the direction of streamflow.

80 On the map *in your answer booklet*, draw an **X** along the streambank where erosion is most likely greater than deposition. [1]

81 The velocity of the stream was determined to be greater at location *B* than at location *A*. State *one* possible reason why the stream velocity was greater at location *B*. [1]

82 Describe *one* change that would occur to an angular pebble as it is transported by this stream for a longer period of time. [1]

Base your answers to questions 83 through 85 on the map below, the data table on the next page, and on your knowledge of Earth science. The map shows the location of the Atacama and Patagonia deserts in relation to the Andes Mountains in South America. The cities of Antofagasta, Chile, and La Junta, Argentina, are shown. The data table shows the average monthly high air temperatures for Antofagasta and La Junta.

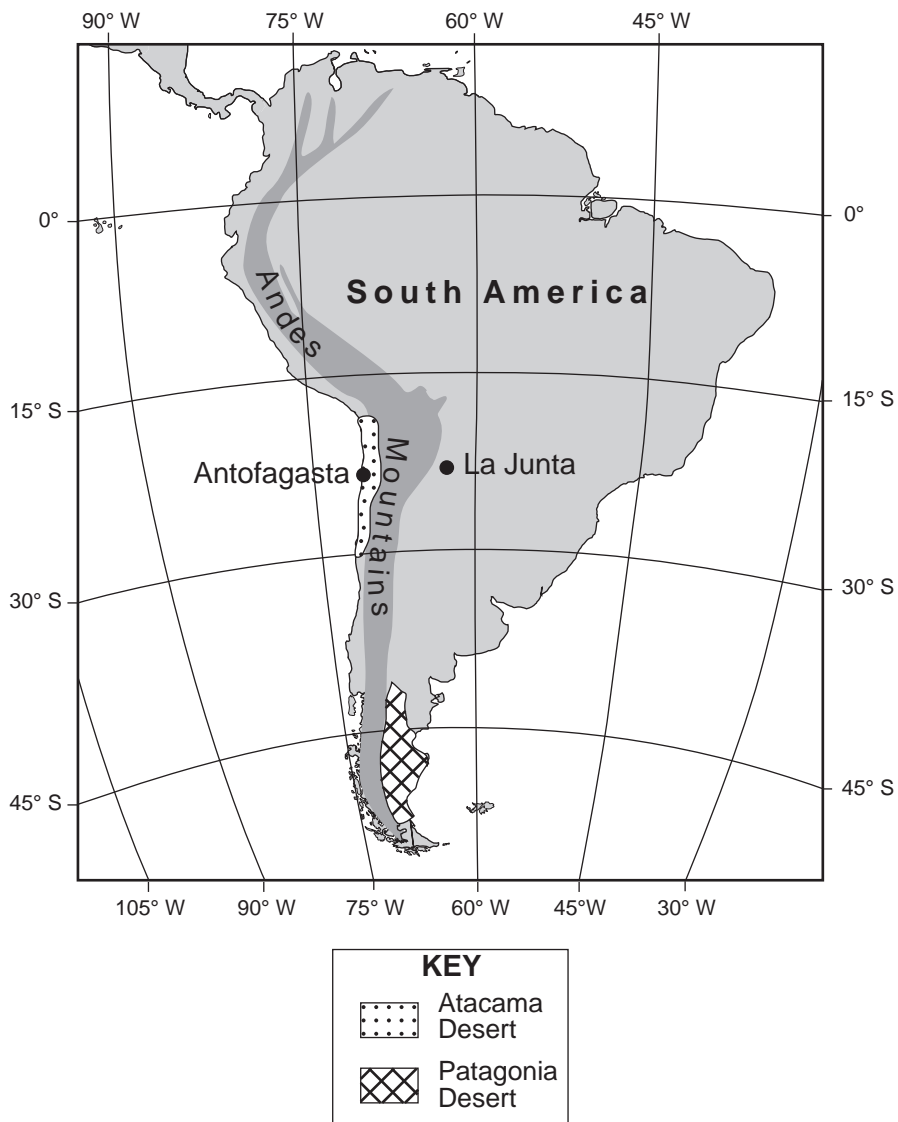

Average Monthly High Air Temperatures

Month	Antofagasta Air Temperature (°C)	La Junta Air Temperature (°C)
January	24	29
February	24	28
March	23	25
April	21	20
May	19	16
June	18	13
July	17	13
August	17	15
September	18	17
October	19	22
November	20	25
December	22	28

- 83 On the graph *in your answer booklet*, construct a line graph by plotting the average monthly high air temperature for La Junta, Argentina, for each month listed on the data table. Connect the plots with a line. The average monthly high air temperatures for Antofagasta, Chile, have already been plotted on the graph. [1]
- 84 State *one* reason Antofagasta, Chile, has a smaller yearly temperature range than La Junta, Argentina. [1]
- 85 Explain why both Antofagasta and La Junta have their coolest air temperatures for the year in June, July, and August, and their warmest air temperatures for the year in December, January, and February. [1]
-

PHYSICAL SETTING EARTH SCIENCE

Thursday, August 17, 2023 — 8:30 to 11:30 a.m., only

ANSWER BOOKLET

Student

Teacher

School Grade

Record your answers for Part B–2 and Part C in this booklet.

Part B–2

51 _____

52 _____

53 _____

54 _____ ly

55 _____

56 Relative luminosity of Alpha Centauri (circle one):
lower luminosity
greater luminosity
same luminosity

Relative mass of Alpha Centauri (circle one):
lower mass
greater mass
same mass

57 _____ **Galaxy**

58 _____

59

Albany, New York Weather Data

Weather Instrument	Numerical Value with Units
anemometer	
precipitation gauge	

60 _____

Alaskan Rebound Isoline Map

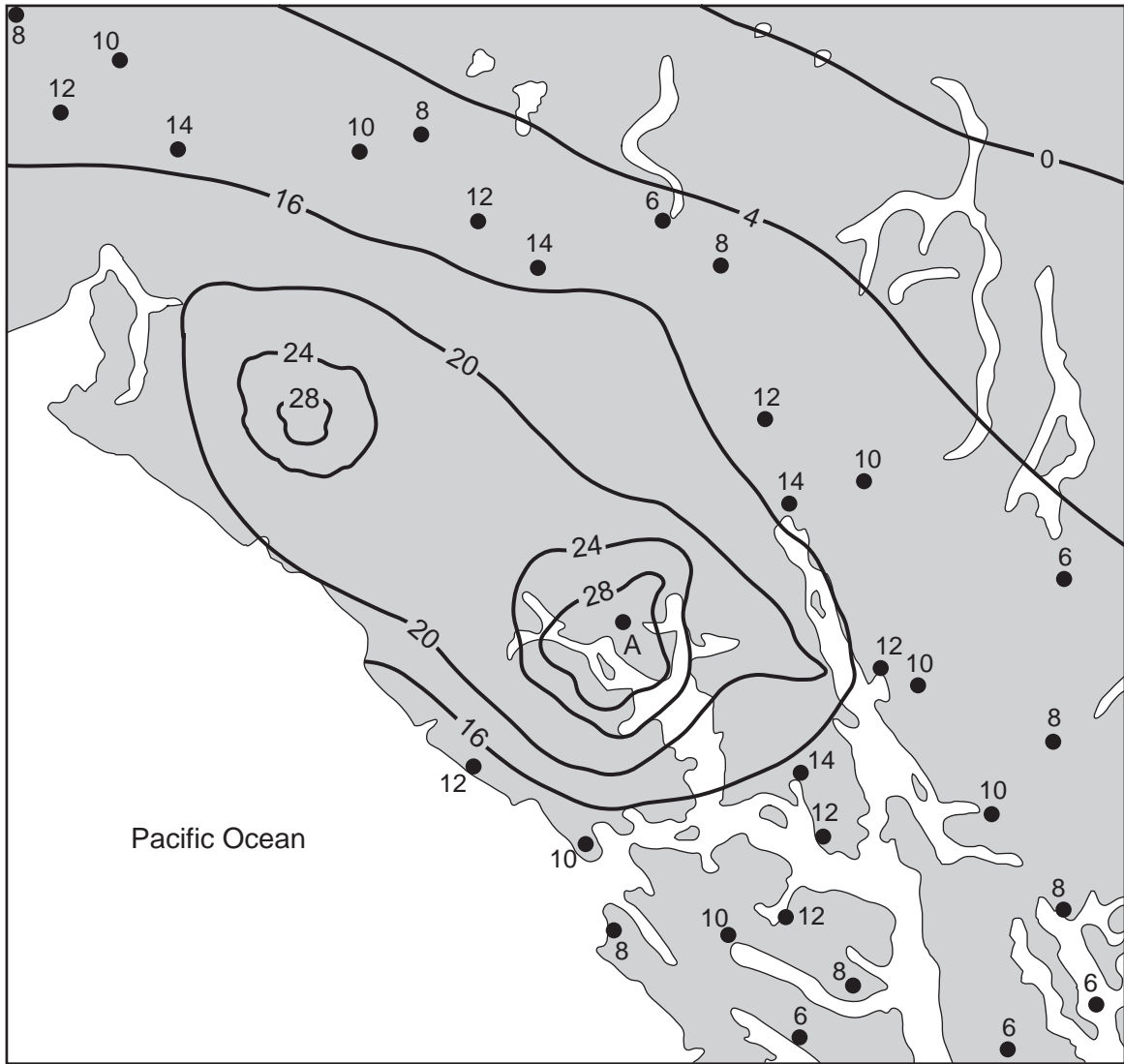

62 _____ mm/y

63 _____

64 _____ Plate and _____ Plate

65 _____ and _____

Part C

66

The Sun's Changing Position at Binghamton, NY

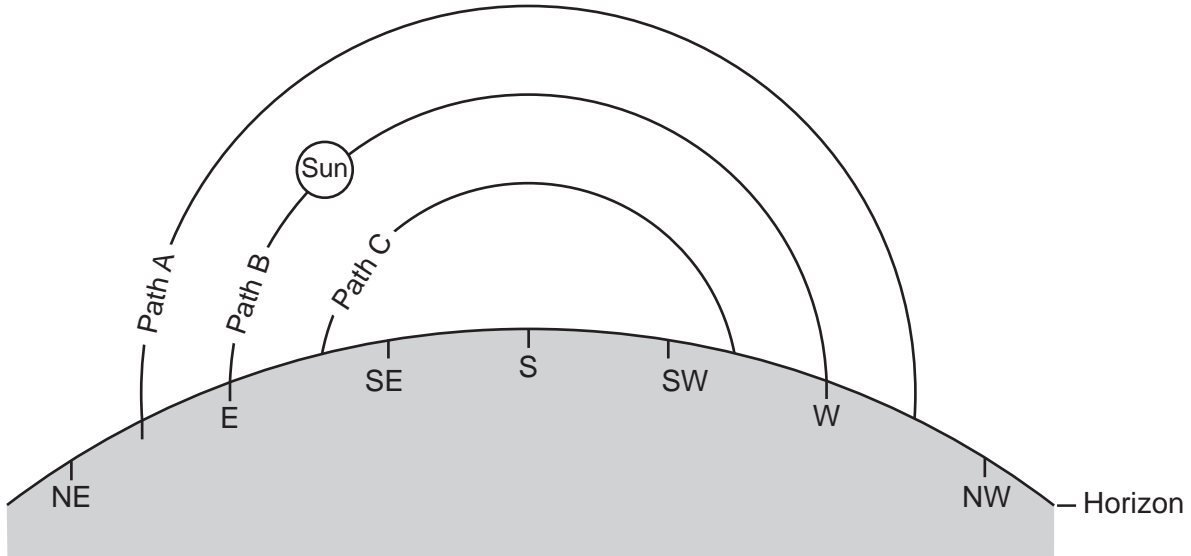

(Not drawn to scale)

67 _____

68 _____

69 Relative intensity of insolation for C (circle one): less intensity
 greater intensity
 same intensity

Relative duration of insolation for C (circle one): shorter duration
 longer duration
 same duration

70 _____ Period

71 _____

72 _____

73 Composition: felsic mafic

Minerals: (1) _____

(2) _____

74 _____

75 _____

76 _____ and _____

77 _____

78 _____ km

79 Rock name: _____

Rock density: _____ g/cm³

80

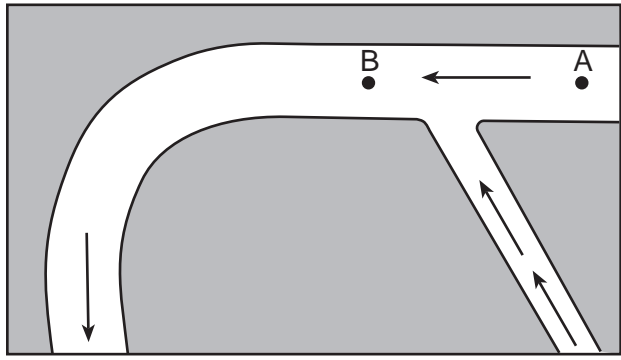

(Not drawn to scale)

81 _____

82 _____

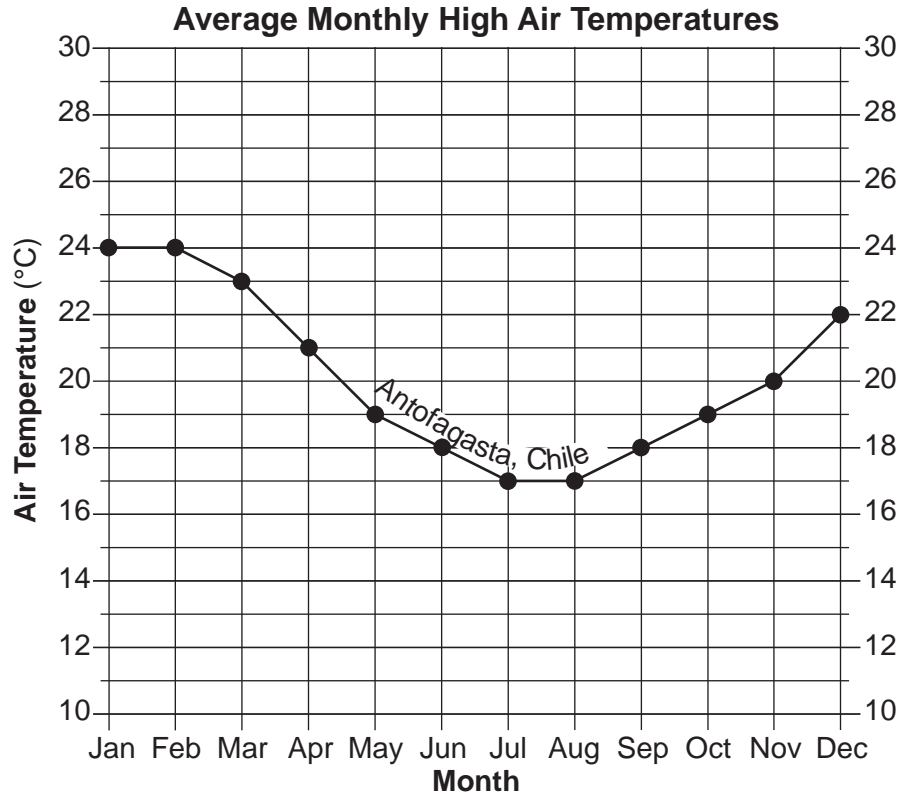

84

85

Regents Examination in Physical Setting/Earth Science – August 2023**Scoring Key: Parts A and B-1 (Multiple-Choice Questions)**

Examination	Date	Question Number	Scoring Key	Question Type	Credit	Weight
Physical Setting/Earth Science	August '23	1	1	MC	1	1
Physical Setting/Earth Science	August '23	2	4	MC	1	1
Physical Setting/Earth Science	August '23	3	2	MC	1	1
Physical Setting/Earth Science	August '23	4	3	MC	1	1
Physical Setting/Earth Science	August '23	5	2	MC	1	1
Physical Setting/Earth Science	August '23	6	4	MC	1	1
Physical Setting/Earth Science	August '23	7	1	MC	1	1
Physical Setting/Earth Science	August '23	8	1	MC	1	1
Physical Setting/Earth Science	August '23	9	3	MC	1	1
Physical Setting/Earth Science	August '23	10	4	MC	1	1
Physical Setting/Earth Science	August '23	11	1	MC	1	1
Physical Setting/Earth Science	August '23	12	4	MC	1	1
Physical Setting/Earth Science	August '23	13	3	MC	1	1
Physical Setting/Earth Science	August '23	14	2	MC	1	1
Physical Setting/Earth Science	August '23	15	1	MC	1	1
Physical Setting/Earth Science	August '23	16	4	MC	1	1
Physical Setting/Earth Science	August '23	17	2	MC	1	1
Physical Setting/Earth Science	August '23	18	4	MC	1	1
Physical Setting/Earth Science	August '23	19	2	MC	1	1
Physical Setting/Earth Science	August '23	20	3	MC	1	1
Physical Setting/Earth Science	August '23	21	1	MC	1	1
Physical Setting/Earth Science	August '23	22	3	MC	1	1
Physical Setting/Earth Science	August '23	23	3	MC	1	1
Physical Setting/Earth Science	August '23	24	4	MC	1	1
Physical Setting/Earth Science	August '23	25	4	MC	1	1
Physical Setting/Earth Science	August '23	26	1	MC	1	1
Physical Setting/Earth Science	August '23	27	3	MC	1	1
Physical Setting/Earth Science	August '23	28	1	MC	1	1
Physical Setting/Earth Science	August '23	29	1	MC	1	1
Physical Setting/Earth Science	August '23	30	2	MC	1	1
Physical Setting/Earth Science	August '23	31	2	MC	1	1
Physical Setting/Earth Science	August '23	32	4	MC	1	1
Physical Setting/Earth Science	August '23	33	2	MC	1	1
Physical Setting/Earth Science	August '23	34	3	MC	1	1
Physical Setting/Earth Science	August '23	35	3	MC	1	1
Physical Setting/Earth Science	August '23	36	2	MC	1	1
Physical Setting/Earth Science	August '23	37	4	MC	1	1
Physical Setting/Earth Science	August '23	38	1	MC	1	1
Physical Setting/Earth Science	August '23	39	2	MC	1	1
Physical Setting/Earth Science	August '23	40	3	MC	1	1
Physical Setting/Earth Science	August '23	41	3	MC	1	1
Physical Setting/Earth Science	August '23	42	1	MC	1	1
Physical Setting/Earth Science	August '23	43	2	MC	1	1
Physical Setting/Earth Science	August '23	44	1	MC	1	1
Physical Setting/Earth Science	August '23	45	3	MC	1	1
Physical Setting/Earth Science	August '23	46	4	MC	1	1
Physical Setting/Earth Science	August '23	47	2	MC	1	1
Physical Setting/Earth Science	August '23	48	3	MC	1	1
Physical Setting/Earth Science	August '23	49	4	MC	1	1
Physical Setting/Earth Science	August '23	50	2	MC	1	1

Regents Examination in Physical Setting/Earth Science – August 2023

Scoring Key: Parts B-2 and C (Constructed-Response Questions)

Examination	Date	Question Number	Scoring Key	Question Type	Credit	Weight
Physical Setting/Earth Science	August '23	51		CR	1	1
Physical Setting/Earth Science	August '23	52		CR	1	1
Physical Setting/Earth Science	August '23	53		CR	1	1
Physical Setting/Earth Science	August '23	54		CR	1	1
Physical Setting/Earth Science	August '23	55		CR	1	1
Physical Setting/Earth Science	August '23	56		CR	1	1
Physical Setting/Earth Science	August '23	57		CR	1	1
Physical Setting/Earth Science	August '23	58		CR	1	1
Physical Setting/Earth Science	August '23	59		CR	1	1
Physical Setting/Earth Science	August '23	60		CR	1	1
Physical Setting/Earth Science	August '23	61		CR	1	1
Physical Setting/Earth Science	August '23	62		CR	1	1
Physical Setting/Earth Science	August '23	63		CR	1	1
Physical Setting/Earth Science	August '23	64		CR	1	1
Physical Setting/Earth Science	August '23	65		CR	1	1
Physical Setting/Earth Science	August '23	66		CR	1	1
Physical Setting/Earth Science	August '23	67		CR	1	1
Physical Setting/Earth Science	August '23	68		CR	1	1
Physical Setting/Earth Science	August '23	69		CR	1	1
Physical Setting/Earth Science	August '23	70		CR	1	1
Physical Setting/Earth Science	August '23	71		CR	1	1
Physical Setting/Earth Science	August '23	72		CR	1	1
Physical Setting/Earth Science	August '23	73		CR	1	1
Physical Setting/Earth Science	August '23	74		CR	1	1
Physical Setting/Earth Science	August '23	75		CR	1	1
Physical Setting/Earth Science	August '23	76		CR	1	1
Physical Setting/Earth Science	August '23	77		CR	1	1
Physical Setting/Earth Science	August '23	78		CR	1	1
Physical Setting/Earth Science	August '23	79		CR	1	1
Physical Setting/Earth Science	August '23	80		CR	1	1
Physical Setting/Earth Science	August '23	81		CR	1	1
Physical Setting/Earth Science	August '23	82		CR	1	1
Physical Setting/Earth Science	August '23	83		CR	1	1
Physical Setting/Earth Science	August '23	84		CR	1	1
Physical Setting/Earth Science	August '23	85		CR	1	1

Key
MC = Multiple-choice question
CR = Constructed-response question

The chart for determining students' final examination scores for the **August 2023 Regents Examination in Physical Setting/Earth Science** will be posted on the Department's web site at <https://www.nysedregents.org/EarthScience/> on the day of the examination. Conversion charts provided for the previous administrations of the Physical Setting/Earth Science examination must NOT be used to determine students' final scores for this administration.

FOR TEACHERS ONLY

The University of the State of New York
REGENTS HIGH SCHOOL EXAMINATION

PHYSICAL SETTING/EARTH SCIENCE

Thursday, August 17, 2023 — 8:30 to 11:30 a.m., only

RATING GUIDE

Directions to the Teacher:

Refer to the directions on page 2 before rating student papers.

Updated information regarding the rating of this examination may be posted on the New York State Education Department's web site during the rating period. Check this web site at: <https://www.nysed.gov/state-assessment/high-school-regents-examinations> and select the link "Scoring Information" for any recently posted information regarding this examination. This site should be checked before the rating process for this examination begins and several times throughout the Regents Examination period.

Directions to the Teacher

Follow the procedures below for scoring student answer papers for the Regents Examination in Physical Setting/Earth Science. Additional information about scoring is provided in the publication *Information Booklet for Scoring Regents Examinations in the Sciences*.

Allow 1 credit for each correct response.

At least two science teachers must participate in the scoring of the Part B–2 and Part C open-ended questions on a student’s paper. Each of these teachers should be responsible for scoring a selected number of the open-ended questions on each answer paper. No one teacher is to score more than approximately one-half of the open-ended questions on a student’s answer paper. Teachers may not score their own students’ answer papers.

Students’ responses must be scored strictly according to the Rating Guide. For open-ended questions, credit may be allowed for responses other than those given in the rating guide if the response is a scientifically accurate answer to the question and demonstrates adequate knowledge as indicated by the examples in the rating guide. Do not attempt to correct the student’s work by making insertions or changes of any kind. On the student’s separate answer sheet, for each question, record the number of credits earned and the teacher’s assigned rater/scorer letter.

Fractional credit is *not* allowed. Only whole-number credit may be given for a response. If the student gives more than one answer to a question, only the first answer should be rated. Units need not be given when the wording of the questions allows such omissions.

For hand scoring, raters should enter the scores earned in the appropriate boxes printed on the separate answer sheet. Next, the rater should add these scores and enter the total in the space provided. The student’s score for the Earth Science Performance Test should be recorded in the space provided. Then the student’s raw scores on the written test and the performance test should be converted to a scale score by using the conversion chart that will be posted on the Department’s web site at: <https://www.nysed.gov/state-assessment/high-school-regents-examinations> on Thursday, August 17, 2023. The student’s scale score should be entered in the box labeled “Scale Score” on the student’s answer sheet. The scale score is the student’s final examination score.

Schools are not permitted to rescore any of the open-ended questions on this exam after each question has been rated once, regardless of the final exam score. Schools are required to ensure that the raw scores have been added correctly and that the resulting scale score has been determined accurately.

Because scale scores corresponding to raw scores in the conversion chart may change from one administration to another, it is crucial that, for each administration, the conversion chart provided for that administration be used to determine the student’s final score.

Part B–2

Allow a maximum of 15 credits for this part.

To ensure the accuracy of overlays, select a printer setting such as *full*, *actual size*, or *100%* when printing this document. Do **not** select the *fit to page* setting.

51 [1] Allow 1 credit. Acceptable responses include, but are not limited to:

- Shale weathers too easily.
- Shale may split easily.
- Shale will break down too quickly.

52 [1] Allow 1 credit. Acceptable responses include, but are not limited to:

- banding
- minerals segregated into bands
- foliation
- contains pyroxene and/or garnet crystals

53 [1] Allow 1 credit. Acceptable responses include, but are not limited to:

- quartz
- potassium feldspar (orthoclase)
- plagioclase feldspar
- feldspar

54 [1] Allow 1 credit for any value from 8.5 to 8.8 ly.

Note: Allow credit if a student indicates a fraction, such as $8\frac{2}{3}$.

55 [1] Allow 1 credit for Barnard's Star.

56 [1] Allow 1 credit for circling *both* greater luminosity and greater mass.

57 [1] Allow 1 credit for the Milky Way Galaxy.

58 [1] Allow 1 credit. Acceptable responses include, but are not limited to:

- fusion
- nuclear fusion
- combining lighter elements into heavier elements
- combining hydrogen into helium

59 [1] Allow 1 credit if *both* responses include the correct numerical value and unit. Acceptable responses include, but are not limited to:

Note: Allow credit for any value from 20.7 miles/hour to 25.3 miles/hour for the anemometer.
Allow credit for “0.31 inches in past 6 hours” for a precipitation gauge unit.

Albany, New York Weather Data

Weather Instrument	Numerical Value with Units
anemometer	Any value from 18 knots to 22 knots
precipitation gauge	.31 inches <i>or</i> 0.31 in <i>or</i> $\frac{31}{100}$ in

60 [1] Allow 1 credit. Acceptable responses include, but are not limited to:

- The air temperature and dewpoint were close in value.
- There is only a 2 F° difference between air temperature and dewpoint.
- A rain shower/rain was occurring.
- Cloud cover was 100%.
- There is low pressure in Albany at this time. / The pressure in Albany has dropped during the past 3 hours.
- low visibility

61 [1] Allow 1 credit if *both* the 8 mm/y and 12 mm/y isolines are correctly drawn with each end drawn to the edge of the map or edge of the land area.

Note: Do *not* allow credit if student-drawn isolines do *not* pass through or touch all 8 and 12 data points.

If additional isolines are drawn, *all* isolines must be correct to receive credit. The isolines need not be continued over the Pacific Ocean.

Example of a 1-credit response:

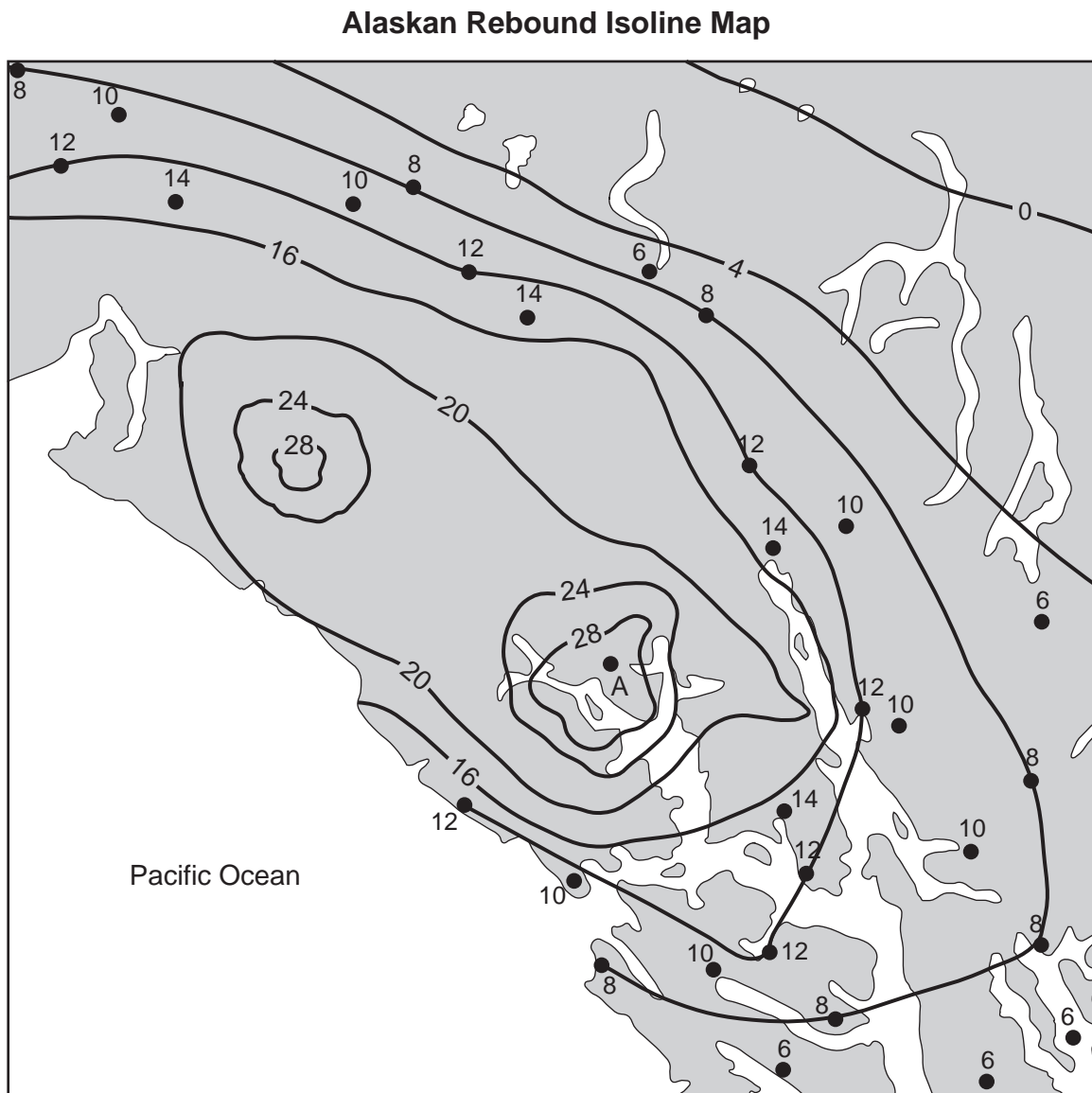

62 [1] Allow 1 credit for any value greater than 28 mm/y but less than 32 mm/y.

63 [1] Allow 1 credit for asthenosphere.

64 [1] Allow 1 credit for *both* Pacific Plate and North American Plate.

65 [1] Allow 1 credit for *two* correct responses. Acceptable responses include, but are not limited to:

- carbon dioxide *or* CO_2
- methane *or* CH_4
- water vapor *or* H_2O
- nitrous oxide *or* N_2O
- ozone *or* O_3
- chlorofluorocarbons *or* CFCs

Part C

Allow a maximum of 20 credits for this part.

- 66 [1] Allow 1 credit if the line is located between path B and path C as shown below. The line representing the Sun's path must extend to the horizon line.

Example of a 1-credit response:

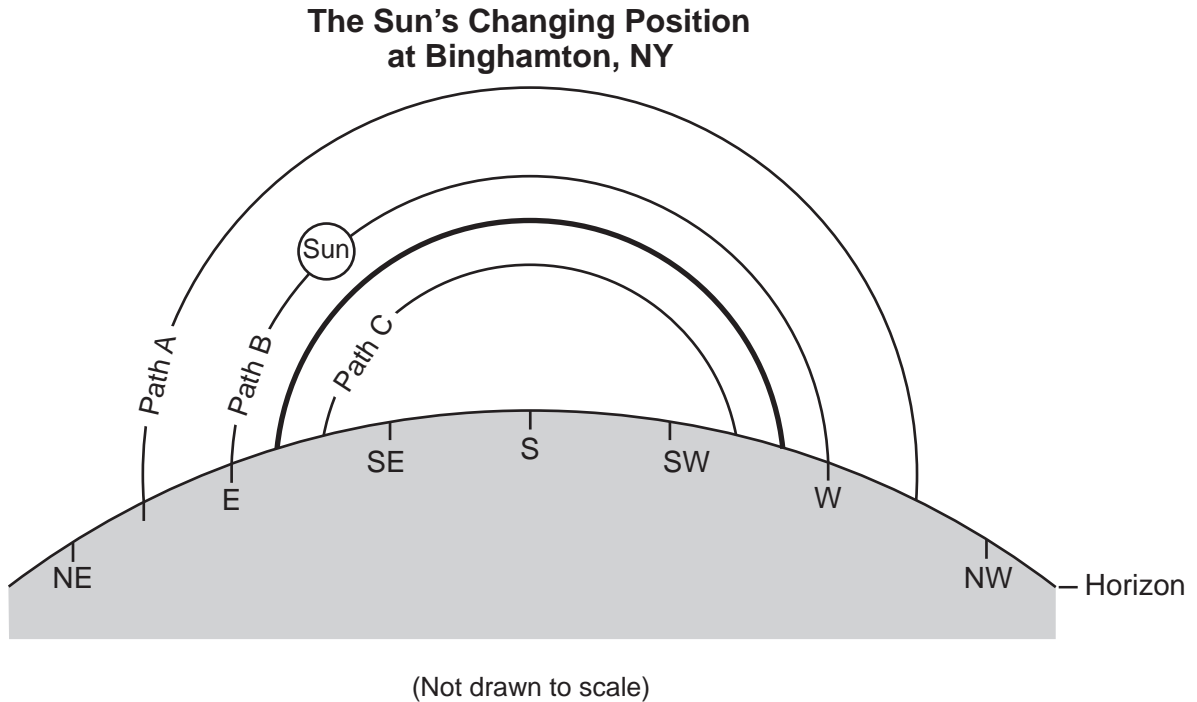

- 67 [1] Allow 1 credit. Acceptable responses include, but are not limited to:
- The length of the shadow will get shorter until solar noon, then longer until sunset.
 - decreases then increases
 - starts long, gets short, then long again

- 68 [1] Allow 1 credit for any value from 8 a.m. to 10 a.m.

Note: Allow credit for a response that indicates “a.m.”, such as 9 in the morning *or* 0900.

- 69 [1] Allow 1 credit for circling *both* less intensity and shorter duration.

70 [1] Allow 1 credit for Silurian Period.

71 [1] Allow 1 credit. Acceptable responses include, but are not limited to:

- widespread geographic distribution
- existed for a short period of geologic time
- easily distinguishable/recognizable

72 [1] Allow 1 credit. Acceptable responses include, but are not limited to:

- A marine environment existed.
- There was an inland sea.
- warm shallow sea
- Part of New York State was underwater.

73 [1] Allow 1 credit for *both* circling felsic and listing two correct minerals. Acceptable responses include, but are not limited to:

- potassium feldspar/orthoclase
- quartz
- plagioclase/plagioclase feldspar
- biotite/biotite mica
- amphibole/hornblende

Note: Allow credit for “feldspar” alone if it is paired only with quartz, biotite/biotite mica *or* amphibole/hornblende.

74 [1] Allow 1 credit for Allegheny Plateau *or* the Catskills *or* Appalachian Plateau (Uplands) *or* Hudson-Mohawk Lowlands *or* Erie-Ontario Lowlands *or* Hudson Highlands.

75 [1] Allow 1 credit. Acceptable responses include, but are not limited to:

- weathering and/or erosion
- The mountain was weathered and eroded by ice and running water.
- Glaciers wore away rock materials.

Note: Do *not* allow credit for the name of an erosional agent along, such as “glaciers” or “running water,” without an explanation of how these erosional agents reduce the mountain size.

76 [1] Allow 1 credit for *both* B and F.

77 [1] Allow 1 credit. Acceptable responses include, but are not limited to:

- H is near a tectonic plate boundary.
- A is farther away from a plate boundary.
- Earthquakes are more frequent at plate boundaries.

78 [1] Allow 1 credit for any value from 2800 km to 2999 km.

79 [1] Allow 1 credit if *both* responses are acceptable. Acceptable responses include, but are not limited to:

Rock name:

- Basalt/basaltic

Rock density:

- 3.0 g/cm^3
- 3 g/cm^3

80 [1] Allow 1 credit if the center of an **X** is within or touches the clear region shown below.

Note: It is recommended that an overlay of the same scale as the student answer sheet be used to ensure reliability in rating.

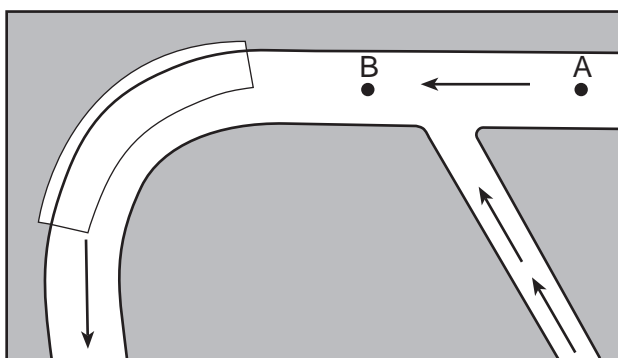

(Not drawn to scale)

81 [1] Allow 1 credit. Acceptable responses include, but are not limited to:

- The discharge volume of water at location B is greater with the additional water from the tributary.
- The volume of water is greater at B.
- The slope at location B could be steeper so the water flows faster.

82 [1] Allow 1 credit. Acceptable responses include, but are not limited to:

- The pebble will become rounder.
- The pebble will decrease in size and mass.
- The pebble will become smoother.
- The pebble will become smaller.

83 [1] Allow 1 credit if the centers of *all twelve* student plots are within or touch the circles shown and are correctly connected with a line that passes within or touches each circle.

Note: Allow credit if the student line does not pass through the student plots but is still within or touches the circles.

It is recommended that an overlay of the same scale as the student answer sheet be used to ensure reliability in rating.

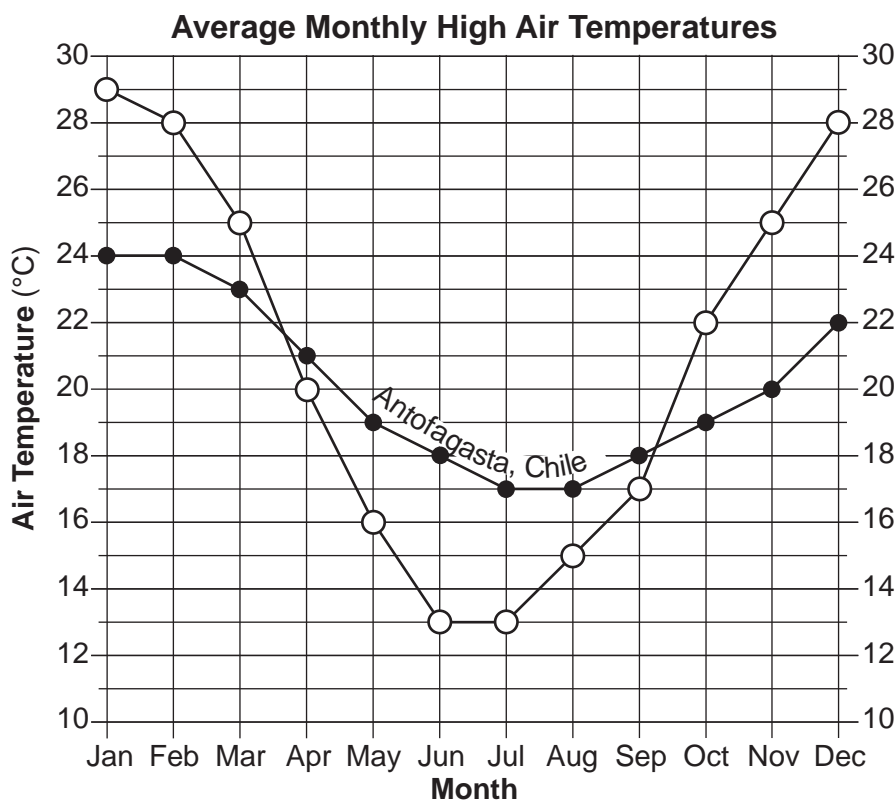

84 [1] Allow 1 credit. Acceptable responses include, but are not limited to:

- Antofagasta is located near a large body of water/ocean.
- La Junta is located in the interior of the continent.
- Large bodies of water moderate air temperatures.
- Antofagasta is a coastal location.
- La Junta's climate is not moderated by a large body of water.
- Water has a high specific heat and changes temperatures more slowly, and Antofagasta is closer to a large body of water.

85 [1] Allow 1 credit. Acceptable responses include, but are not limited to:

- Earth’s southern axis is tilted toward the Sun in December, January, and February, producing warmer temperatures.
- In the Southern Hemisphere, summer occurs in December, January, and February, and winter occurs in June, July, and August.
- The intensity and duration of insolation is greatest in December, January, and February at these locations.
- Both cities are located in the Southern Hemisphere.

Note: Do *not* allow credit for “the cities are located in South America” or “South America is located below the equator” because parts of South America are located above the equator.

Do *not* allow credit for “the Southern Hemisphere faces the Sun” because part of the Northern Hemisphere also faces the Sun during daylight hours.

Do *not* allow credit for “Earth is tilted toward the Sun” because only the Southern Hemisphere is tilted toward the Sun.

Regents Examination in Physical Setting/Earth Science

August 2023

Chart for Converting Total Test Raw Scores to Final Examination Scores (Scale Scores)

The *Chart for Determining the Final Examination Score for the August 2023 Regents Examination in Physical Setting/Earth Science* will be posted on the Department's web site at: <https://www.nysed.gov/state-assessment/high-school-regents-examinations> on Thursday, August 17, 2023. Conversion charts provided for previous administrations of the Regents Examination in Physical Setting/Earth Science must NOT be used to determine students' final scores for this administration.

Online Submission of Teacher Evaluations of the Test to the Department

Suggestions and feedback from teachers provide an important contribution to the test development process. The Department provides an online evaluation form for State assessments. It contains spaces for teachers to respond to several specific questions and to make suggestions. Instructions for completing the evaluation form are as follows:

1. Go to <https://www.nysed.gov/state-assessment/teacher-feedback-state-assessments>.
2. Select the test title.
3. Complete the required demographic fields.
4. Complete each evaluation question and provide comments in the space provided.
5. Click the SUBMIT button at the bottom of the page to submit the completed form.

Map to Core Curriculum

August 2023 Physical Setting/Earth Science			
Question Numbers			
Key Ideas/Performance Indicators	Part A	Part B	Part C
Standard 1			
Math Key Idea 1			83
Math Key Idea 2	9, 22, 28	54, 55, 56	
Math Key Idea 3	10	33	80
Science Inquiry Key Idea 1	29	36, 37, 45, 49, 58	71, 75, 77, 81, 84, 85
Science Inquiry Key Idea 2			
Science Inquiry Key Idea 3	5, 7, 10, 15, 16, 17, 18, 19, 21, 23, 25, 26, 27, 32	39, 40, 43, 45, 46, 50, 51, 52, 53, 56, 59, 60, 63, 64	67, 70, 72, 73, 74, 76, 78, 79
Engineering Design Key Idea 1			
Standard 2			
Key Idea 1			
Key Idea 2			
Key Idea 3			
Standard 6			
Key Idea 1		57	80
Key Idea 2	2, 6, 8, 10, 12, 14, 15, 16, 17, 29, 30, 31, 32, 33, 34, 35	38, 41, 42, 44, 47, 48, 54, 55, 59, 60, 61, 62, 63, 64	66, 67, 68, 70, 72, 77, 78, 81
Key Idea 3		62	
Key Idea 4			
Key Idea 5	8	41, 47, 61, 65	66, 67, 68, 69, 75, 78, 82, 84
Key Idea 6			
Standard 7			
Key Idea 1			
Key Idea 2			
Standard 4			
Key Idea 1	1, 2, 3, 4, 5, 6, 7, 8, 9, 10, 11, 12, 21, 22, 23, 29	38, 39, 40, 41, 42, 43, 44, 45, 46, 47, 54, 55, 56, 57, 58	66, 67, 68, 70, 71, 74
Key Idea 2	13, 14, 15, 16, 17, 18, 19, 20, 24, 28, 30, 31, 32, 33, 34, 35	36, 37, 48, 49, 50, 59, 60, 61, 62, 63, 64, 65	69, 74, 75, 76, 77, 78, 79, 80, 81, 82, 83, 84, 85
Key Idea 3	25, 26, 27	51, 52, 53	73
Reference Tables			
ESRT 2011 Edition (Revised)	5, 7, 10, 15, 16, 17, 18, 19, 21, 23, 25, 26, 27, 32	39, 40, 43, 45, 46, 50, 52, 53, 56, 59, 60, 63, 64	70, 72, 73, 74, 76, 78, 79

The State Education Department / The University of the State of New York
Regents Examination in Physical Setting/Earth Science – August 2023
Chart for Converting Total Test Raw Scores to Final Examination Scores (Scale Scores)
(Not to be used for the Braille Edition)

To determine the student's final score, locate the student's Total Performance Test Score across the top of the chart and the Total Written Test Score down the side of the chart. The point where the two scores intersect is the student's final examination score. For example, a student receiving a Total Performance Test Score of 9 and Total Written Test Score of 65 would receive a final examination score of 85.

		Total Performance Test Score																
		16	15	14	13	12	11	10	9	8	7	6	5	4	3	2	1	0
Total Written Test Score	85	100	99	99	99	98	98	97	96	96	95	94	93	91	90	88	87	85
	84	99	99	98	98	98	97	96	96	95	94	93	92	91	89	88	86	84
	83	99	99	98	98	98	97	96	96	95	94	93	92	91	89	88	86	84
	82	98	98	98	97	97	96	95	95	94	93	92	91	90	88	87	85	83
	81	98	98	98	97	97	96	95	95	94	93	92	91	90	88	87	85	83
	80	97	97	97	96	96	95	95	94	93	92	91	90	89	88	86	84	82
	79	97	96	96	95	95	94	94	93	92	91	90	89	88	87	85	83	82
	78	97	96	96	95	95	94	94	93	92	91	90	89	88	87	85	83	82
	77	96	95	95	95	94	94	93	92	91	91	89	88	87	86	84	83	81
	76	95	95	94	94	93	93	92	91	91	90	89	88	86	85	83	82	80
	75	95	95	94	94	93	93	92	91	91	90	89	88	86	85	83	82	80
	74	94	94	93	93	92	92	91	90	90	89	88	87	86	84	83	81	79
	73	93	93	92	92	92	91	90	90	89	88	87	86	85	83	82	80	78
	72	92	92	92	91	91	90	90	89	88	87	86	85	84	82	81	79	77
	71	92	92	92	91	91	90	90	89	88	87	86	85	84	82	81	79	77
	70	92	91	91	90	90	89	89	88	87	86	85	84	83	82	80	78	77
	69	91	90	90	89	89	88	88	87	86	85	84	83	82	81	79	77	76
	68	90	90	89	89	88	88	87	86	85	85	84	82	81	80	78	77	75
	67	89	89	88	88	87	87	86	85	85	84	83	82	80	79	77	76	74
	66	89	89	88	88	87	87	86	85	85	84	83	82	80	79	77	76	74
	65	88	88	87	87	86	86	85	85	84	83	82	81	80	78	77	75	73
64	87	87	87	86	86	85	84	84	83	82	81	80	79	77	76	74	72	
63	86	86	86	85	85	84	84	83	82	81	80	79	78	77	75	73	71	
62	86	85	85	84	84	83	83	82	81	80	79	78	77	76	74	72	71	
61	85	84	84	84	83	82	82	81	80	79	78	77	76	75	73	72	70	
60	84	84	83	83	82	82	81	80	80	79	78	77	75	74	72	71	69	
59	83	83	82	82	81	81	80	79	79	78	77	76	74	73	71	70	68	
58	83	83	82	82	81	81	80	79	79	78	77	76	74	73	71	70	68	
57	82	82	81	81	81	80	79	79	78	77	76	75	74	72	71	69	67	
56	81	81	81	80	80	79	78	78	77	76	75	74	73	71	70	68	66	
55	80	80	80	79	79	78	78	77	76	75	74	73	72	71	69	67	65	
54	80	79	79	78	78	77	77	76	75	74	73	72	71	70	68	66	65	
53	79	78	78	78	77	77	76	75	74	74	72	71	70	69	67	66	64	
52	78	78	77	77	76	76	75	74	74	73	72	71	69	68	66	65	63	
51	77	77	76	76	75	75	74	73	73	72	71	70	69	67	66	64	62	
50	76	76	75	75	75	74	73	73	72	71	70	69	68	66	65	63	61	
49	75	75	75	74	74	73	73	72	71	70	69	68	67	65	64	62	60	
48	75	74	74	73	73	72	72	71	70	69	68	67	66	65	63	61	60	
47	74	73	73	72	72	71	71	70	69	68	67	66	65	64	62	60	59	
46	72	72	71	71	70	70	69	68	68	67	66	65	63	62	60	59	57	
45	71	71	70	70	69	69	68	68	67	66	65	64	63	61	60	58	56	

Final Examination Scores
Regents Examination in Physical Setting/Earth Science – August 2023 – continued

		Total Performance Test Score																
		16	15	14	13	12	11	10	9	8	7	6	5	4	3	2	1	0
Total Written Test Score	44	70	70	70	69	69	68	67	67	66	65	64	63	62	60	59	57	55
	43	69	69	69	68	68	67	67	66	65	64	63	62	61	60	58	56	54
	42	69	68	68	67	67	66	66	65	64	63	62	61	60	59	57	55	54
	41	68	67	67	67	66	65	65	64	63	62	61	60	59	58	56	55	53
	40	67	67	66	66	65	65	64	63	63	62	61	60	58	57	55	54	52
	39	65	65	64	64	64	63	62	62	61	60	59	58	57	55	54	52	50
	38	64	64	64	63	63	62	61	61	60	59	58	57	56	54	53	51	49
	37	63	63	63	62	62	61	61	60	59	58	57	56	55	54	52	50	48
	36	63	62	62	61	61	60	60	59	58	57	56	55	54	53	51	49	48
	35	62	61	61	61	60	60	59	58	57	57	55	54	53	52	50	49	47
	34	60	60	59	59	58	58	57	56	56	55	54	53	52	50	49	47	45
	33	59	59	58	58	58	57	56	56	55	54	53	52	51	49	48	46	44
	32	58	58	58	57	57	56	56	55	54	53	52	51	50	48	47	45	43
	31	57	56	56	55	55	54	54	53	52	51	50	49	48	47	45	43	42
	30	56	56	55	55	54	54	53	52	51	51	50	48	47	46	44	43	41
	29	55	55	54	54	53	53	52	51	51	50	49	48	46	45	43	42	40
	28	53	53	53	52	52	51	50	50	49	48	47	46	45	43	42	40	38
	27	52	52	52	51	51	50	50	49	48	47	46	45	44	43	41	39	37
	26	51	50	50	50	49	48	48	47	46	45	44	43	42	41	39	38	36
	25	50	50	49	49	48	48	47	46	46	45	44	43	41	40	38	37	35
	24	48	48	47	47	47	46	45	45	44	43	42	41	40	38	37	35	33
	23	47	47	47	46	46	45	44	44	43	42	41	40	39	37	36	34	32
	22	46	46	46	45	45	44	44	43	42	41	40	39	38	37	35	33	31
	21	45	44	44	44	43	43	42	41	40	40	38	37	36	35	33	32	30
	20	44	44	43	43	42	42	41	40	40	39	38	37	35	34	32	31	29
	19	42	42	41	41	41	40	39	39	38	37	36	35	34	32	31	29	27
	18	41	40	40	39	39	38	38	37	36	35	34	33	32	31	29	27	26
	17	40	39	39	38	38	37	37	36	35	34	33	32	31	30	28	26	25
	16	38	38	37	37	36	36	35	34	34	33	32	31	29	28	26	25	23
	15	37	37	36	36	35	35	34	34	33	32	31	30	29	27	26	24	22
	14	35	35	35	34	34	33	33	32	31	30	29	28	27	26	24	22	20
	13	34	33	33	33	32	31	31	30	29	28	27	26	25	24	22	21	19
	12	33	33	32	32	31	31	30	29	29	28	27	26	24	23	21	20	18
	11	31	31	30	30	30	29	28	28	27	26	25	24	23	21	20	18	16
	10	30	30	30	29	29	28	27	27	26	25	24	23	22	20	19	17	15
	9	29	28	28	27	27	26	26	25	24	23	22	21	20	19	17	15	14
	8	27	27	26	26	25	25	24	23	23	22	21	20	18	17	15	14	12
	7	25	25	24	24	24	23	22	22	21	20	19	18	17	15	14	12	10
	6	24	24	24	23	23	22	22	21	20	19	18	17	16	14	13	11	9
	5	23	22	22	21	21	20	20	19	18	17	16	15	14	13	11	9	8
	4	21	21	20	20	19	19	18	17	17	16	15	14	12	11	9	8	6
	3	19	19	19	18	18	17	16	16	15	14	13	12	11	9	8	6	4
	2	18	18	18	17	17	16	16	15	14	13	12	11	10	9	7	5	3
	1	17	16	16	16	15	14	14	13	12	11	10	9	8	7	5	4	2
	0	15	15	14	14	13	13	12	11	11	10	9	8	6	5	3	2	0