

The University of the State of New York  
REGENTS HIGH SCHOOL EXAMINATION

**PHYSICAL SETTING**  
**EARTH SCIENCE**

Wednesday, August 13, 2008 — 12:30 to 3:30 p.m., only

This is a test of your knowledge of Earth science. Use that knowledge to answer all questions in this examination. Some questions may require the use of the *Earth Science Reference Tables*. The *Earth Science Reference Tables* are supplied separately. Be certain you have a copy of the *2001 Edition (Revised November 2006)* of these reference tables before you begin the examination.

Your answer sheet for Part A and Part B–1 is the last page of this examination booklet. Turn to the last page and fold it along the perforations. Then, slowly and carefully, tear off your answer sheet and fill in the heading.

The answers to the questions in Part B–2 and Part C are to be written in your separate answer booklet. Be sure to fill in the heading on the front of your answer booklet.

You are to answer *all* questions in all parts of this examination according to the directions provided in the examination booklet. Record your answers to the Part A and Part B–1 multiple-choice questions on your separate answer sheet. Write your answers to the Part B–2 and Part C questions in your answer booklet. All work should be written in pen, except for graphs and drawings, which should be done in pencil. You may use scrap paper to work out the answers to the questions, but be sure to record all your answers on your separate answer sheet and in your answer booklet.

When you have completed the examination, you must sign the statement printed at the end of your separate answer sheet, indicating that you had no unlawful knowledge of the questions or answers prior to the examination and that you have neither given nor received assistance in answering any of the questions during the examination. Your answer sheet and answer booklet cannot be accepted if you fail to sign this declaration.

Notice. . .

A four-function or scientific calculator and a copy of the *2001 Earth Science Reference Tables (Revised November 2006)* must be available for you to use while taking this examination.

The use of any communications device is strictly prohibited when taking this examination. If you use any communications device, no matter how briefly, your examination will be invalidated and no score will be calculated for you.

**DO NOT OPEN THIS EXAMINATION BOOKLET UNTIL THE SIGNAL IS GIVEN.**

## Part A

### Answer all questions in this part.

*Directions (1–35):* For *each* statement or question, write on your separate answer sheet the *number* of the word or expression that, of those given, best completes the statement or answers the question. Some questions may require the use of the *Earth Science Reference Tables*.

1 Which statement best describes the age of our solar system and the universe?

- (1) The universe is at least twice as old as our solar system.
- (2) Our solar system is at least twice as old as the universe.
- (3) Our solar system and the universe are estimated to be 5 billion years old.
- (4) Our solar system and the universe are estimated to be 10 billion years old.

2 A Foucault pendulum is used to prove that

- (1) the Sun rotates on its axis
- (2) the Sun revolves around Earth
- (3) Earth rotates on its axis
- (4) Earth revolves around the Sun

3 Compared to the terrestrial planets, the Jovian planets are

- (1) smaller and have lower densities
- (2) smaller and have greater densities
- (3) larger and have lower densities
- (4) larger and have greater densities

4 Which process produces the energy that allows the stars of the universe to radiate visible light?

- (1) convection
- (2) nuclear fusion
- (3) insolation
- (4) radioactive decay

5 A soil sample with a large amount of space between the particles will have a

- (1) low permeability rate
- (2) low infiltration rate
- (3) high porosity
- (4) high capillarity

6 When Earth cools, most of the energy transferred from Earth's surface to space is transferred by the process of

- (1) conduction
- (2) reflection
- (3) refraction
- (4) radiation

7 The spinning of Earth on its axis causes the apparent rising and setting of the

- (1) Sun, only
- (2) Sun and the Moon, only
- (3) Moon and some stars, only
- (4) Sun, the Moon, and some stars

8 On sunny summer days, a breeze often develops that blows from large bodies of water toward nearby landmasses because the

- (1) temperature of the air above the landmasses is greater
- (2) specific heat of the landmasses is greater
- (3) temperatures of the bodies of water are greater
- (4) air over the bodies of water becomes heavier with additional water vapor

9 The topographic map below shows part of a stream.

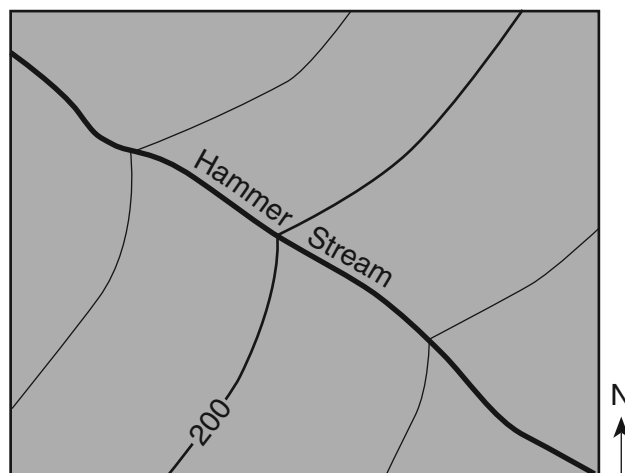

In which general direction is the stream flowing?

- (1) northeast
- (2) northwest
- (3) southeast
- (4) southwest

10 Which pair of shaded circles best represents the relative sizes of Earth and Venus when drawn to scale?

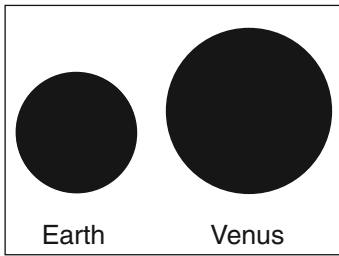

( 1 )

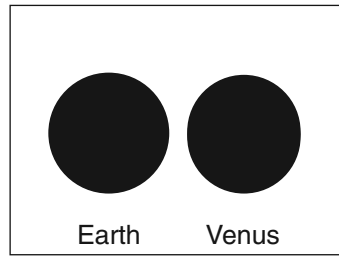

( 2 )

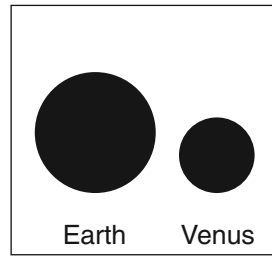

( 3 )

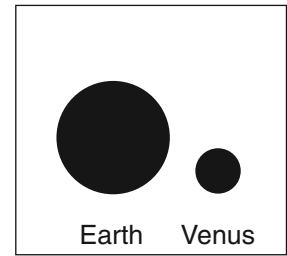

( 4 )

11 The weather instrument below is used to determine dewpoint and relative humidity.

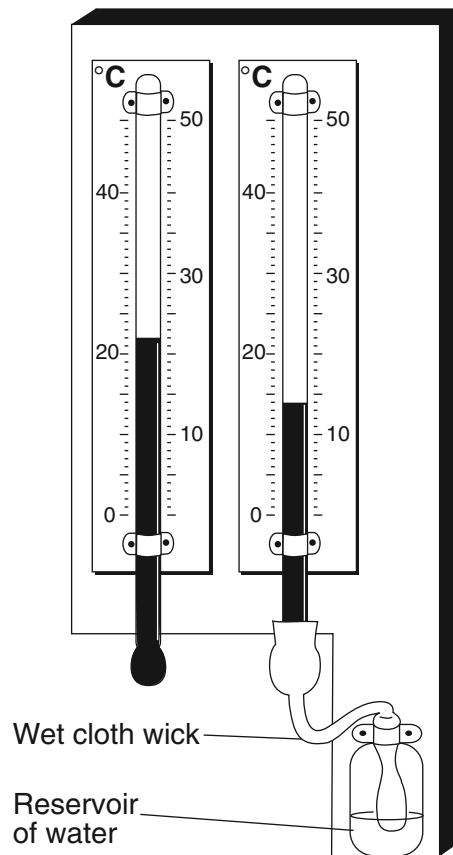

Based on the temperatures shown, the approximate dewpoint and relative humidity are

- (1)  $-19^{\circ}\text{C}$  and 4%  
(2)  $-5^{\circ}\text{C}$  and 25%

- (3)  $8^{\circ}\text{C}$  and 40%  
(4)  $12^{\circ}\text{C}$  and 53%

Base your answers to questions 12 through 14 on the weather map below, which shows a high-pressure center (**H**) and a low-pressure center (**L**), with two fronts extending from the low-pressure center. Points X and Y are locations on the map connected by a reference line.

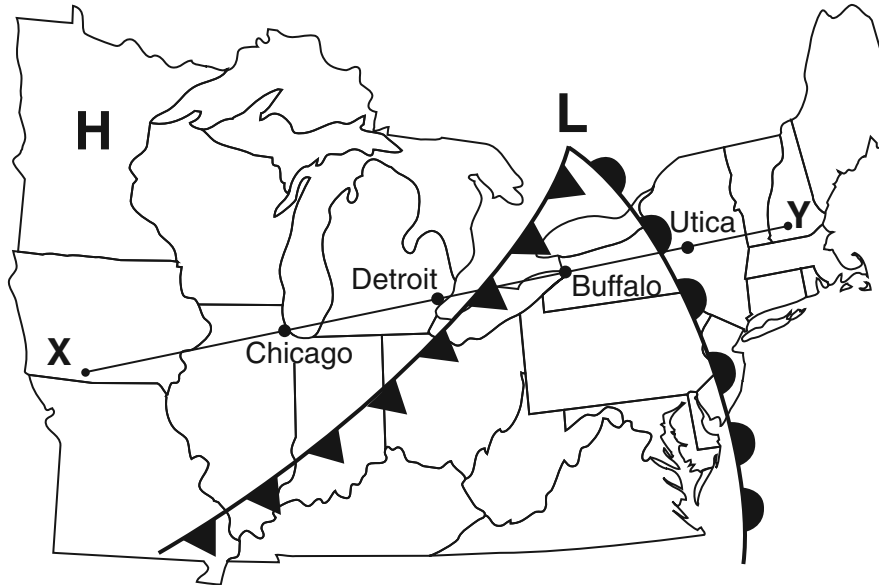

12 Which type of front is located between Buffalo and Detroit?

- (1) stationary
- (2) warm
- (3) occluded
- (4) cold

13 Which cross section best represents the fronts and air movements in the lower atmosphere along line XY?

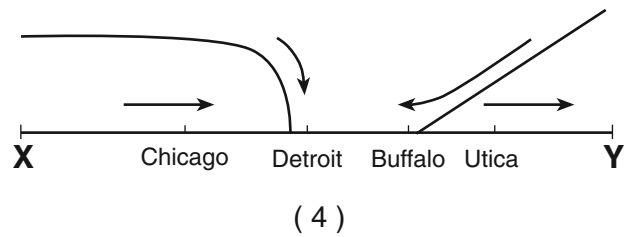
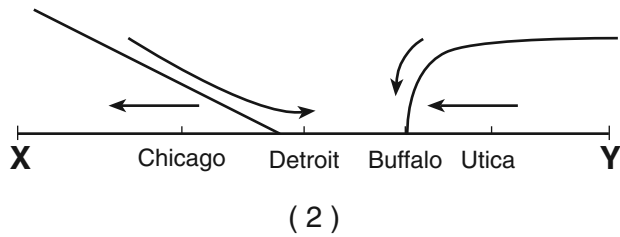
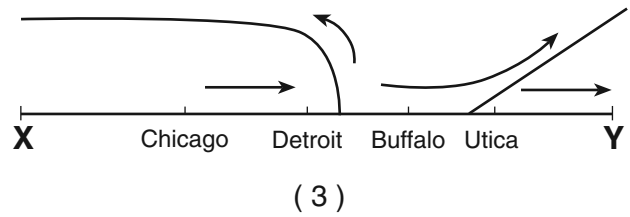
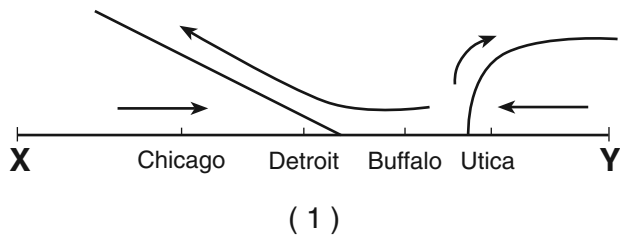

14 Which map best shows the most probable areas of precipitation associated with these weather systems?

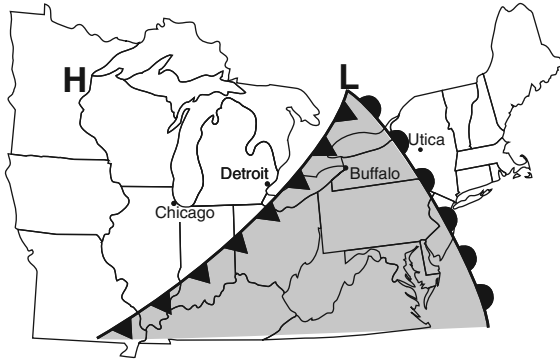
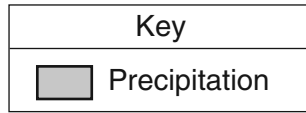

(1)

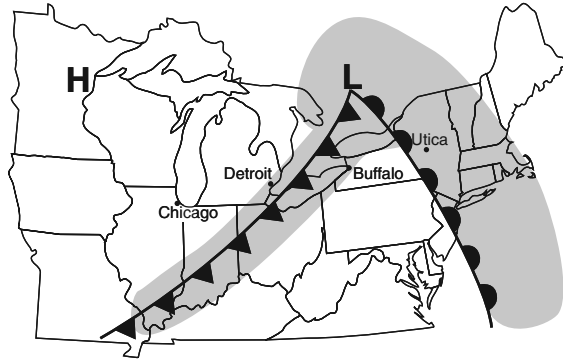

(3)

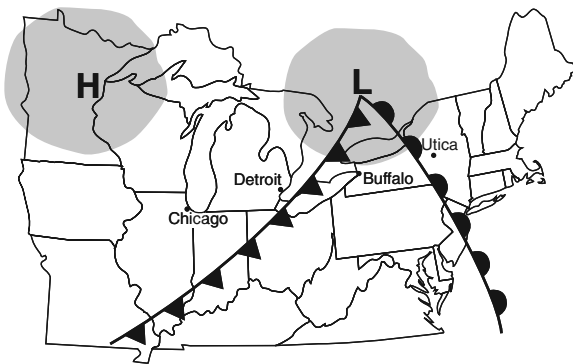

(2)

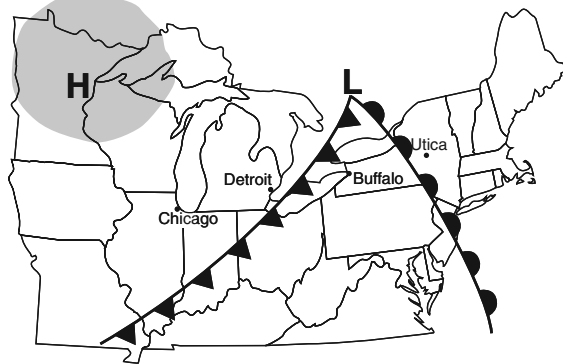

(4)

15 Which graph best shows the general relationship between the altitude of the noontime Sun and the intensity of insolation received at a location?

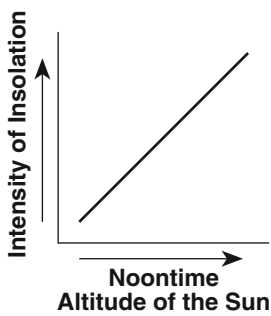

(1)

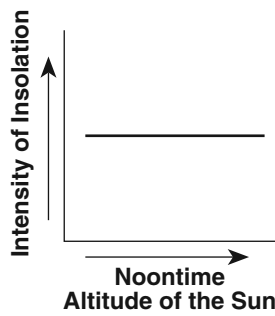

(2)

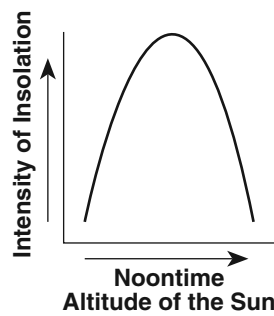

(3)

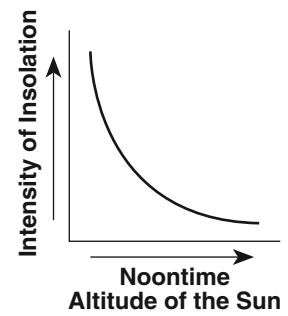

(4)

- 16 The cross section below shows the direction of air flowing over a mountain. Points A and B are at the same elevation on opposite sides of the mountain.

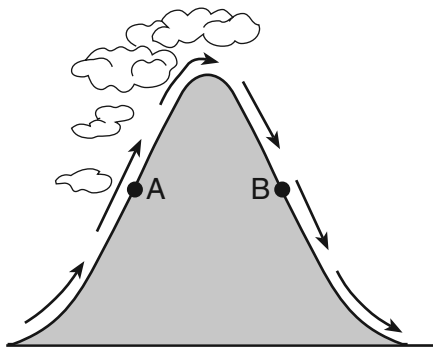

Compared to the air temperature and humidity at point A, the air temperature and humidity at point B are usually

- (1) cooler and drier           (3) warmer and drier  
 (2) cooler and wetter       (4) warmer and wetter
- 17 The cross section below shows rock layers A, B, C, D, and fault F. The rock layers have not been overturned.

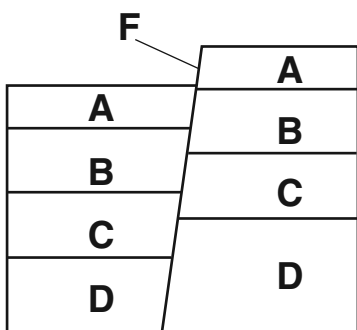

Which sequence places the rock layers and fault in order from oldest to youngest?

- (1)  $D \rightarrow C \rightarrow B \rightarrow A \rightarrow F$   
 (2)  $A \rightarrow B \rightarrow C \rightarrow D \rightarrow F$   
 (3)  $F \rightarrow D \rightarrow C \rightarrow B \rightarrow A$   
 (4)  $F \rightarrow A \rightarrow B \rightarrow C \rightarrow D$
- 18 The largest sediment particles that can be transported by a stream traveling at a velocity of 200 centimeters per second are
- (1) boulders                   (3) pebbles  
 (2) cobbles                   (4) sand

- 19 What happens to the density and temperature of rock within Earth's interior as depth increases?

- (1) density decreases and temperature decreases  
 (2) density decreases and temperature increases  
 (3) density increases and temperature increases  
 (4) density increases and temperature decreases

- 20 Scientists believe that a large asteroid struck Earth approximately 65 million years ago. It is often theorized that this event contributed to the

- (1) end of the last ice age  
 (2) breaking up of the supercontinent Pangea  
 (3) evolution of the first birds  
 (4) extinction of the dinosaurs

- 21 Which two landscape regions in New York State have the oldest surface bedrock?

- (1) Allegheny Plateau and Newark Lowlands  
 (2) Tug Hill Plateau and Erie-Ontario Lowlands  
 (3) Taconic Mountains and the Catskills  
 (4) Adirondack Mountains and Hudson Highlands

- 22 The topographic map below shows locations X and Y.

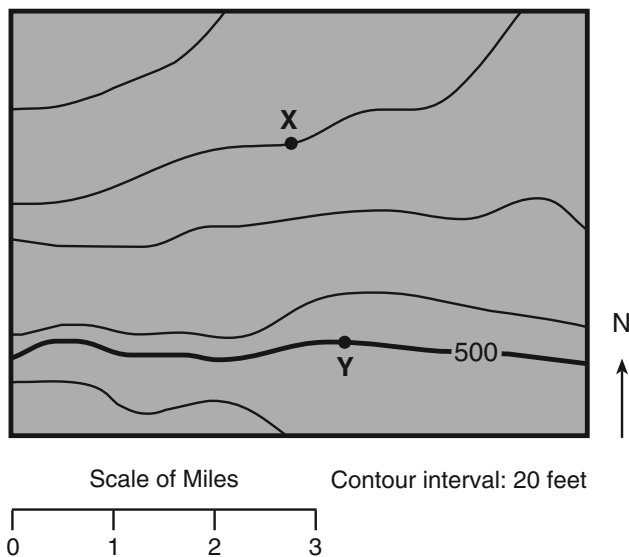



What is the approximate gradient between X and Y?

- (1) 15 ft/mi                   (3) 30 ft/mi  
 (2) 20 ft/mi                   (4) 60 ft/mi

23 The diagram below represents a sample of a radioactive isotope.

Sample before decay



Key	
	Radioactive isotope
	Decay product

Which diagram best represents the percentage of this radioactive isotope sample that will remain after 2 half-lives?



(1)



(2)



(3)



(4)

24 Which map best indicates the probable locations of continents 100 million years from now if tectonic plate movement continues at its present rate and direction?

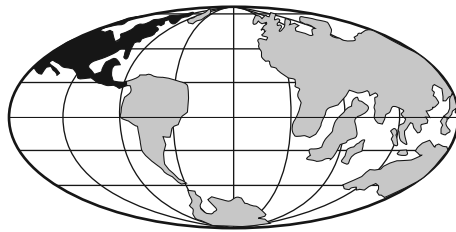

(1)

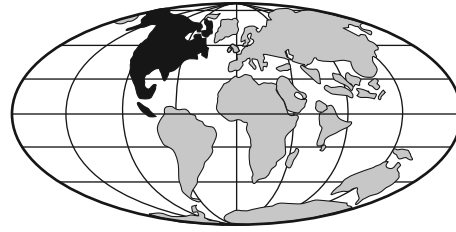

(3)

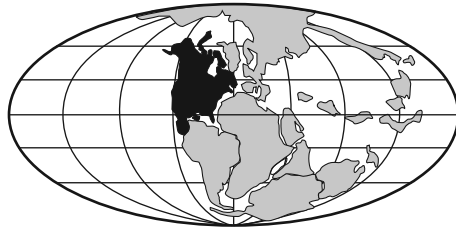

(2)

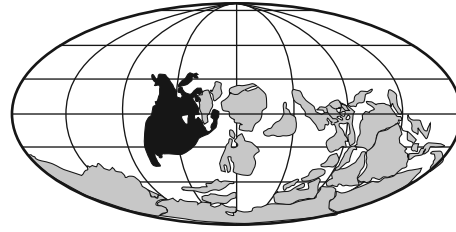

(4)

25 Which graph best represents the relationship between the slope of a river and the particle size that can be transported by that river?

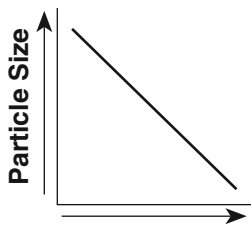

(1)

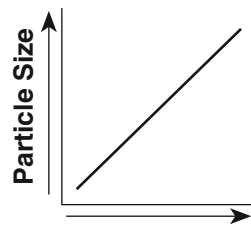

(2)

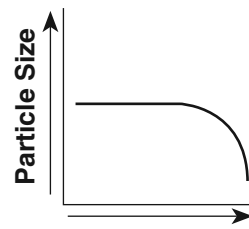

(3)

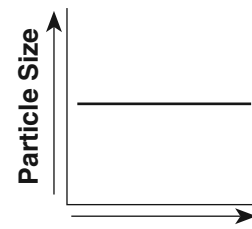

(4)

Base your answers to questions 26 and 27 on the photograph below, which shows a bedrock outcrop in northeastern New York State. Line *AB* is an unconformity between sandstone *C* and metamorphic rock *D*.

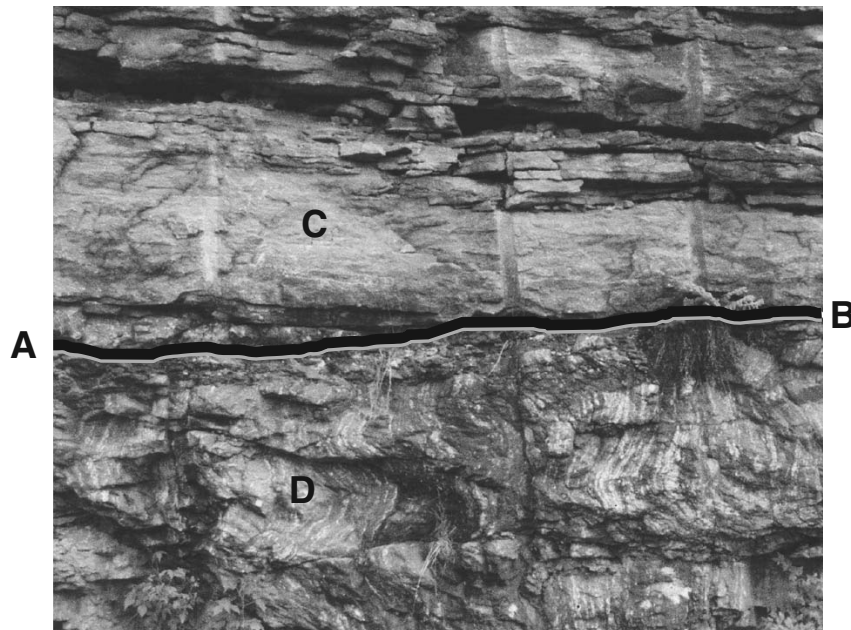

26 The lower layers of sediment found in sandstone *C* were deposited 520 million years ago. During which period of geologic time did this deposition occur?

- (1) Cambrian
- (2) Ordovician
- (3) Silurian
- (4) Triassic

27 After the metamorphism of rock *D*, which sequence of events most probably formed unconformity *AB*?

- (1) flooding → deposition → erosion → uplift
- (2) uplift → erosion → flooding → deposition
- (3) deposition → flooding → uplift → erosion
- (4) erosion → flooding → uplift → deposition

---

28 Which agent of erosion was primarily responsible for forming the long, narrow, U-shaped valleys in the Finger Lakes region of New York State?

- (1) wind
- (2) landslides
- (3) meandering streams
- (4) continental glaciers

29 Which observation about the Mid-Atlantic Ridge region provides the best evidence that the seafloor has been spreading for millions of years?

- (1) The bedrock of the ridge and nearby seafloor is igneous rock.
- (2) The ridge is the location of irregular volcanic eruptions.
- (3) Several faults cut across the ridge and nearby seafloor.
- (4) Seafloor bedrock is younger near the ridge and older farther away.



30 The diagram below shows the index minerals of Mohs hardness scale compared with the hardness of some common objects.

Index Minerals		Common Objects
Diamond	10	
Corundum	9	
Topaz	8	
Quartz	7	Steel file
Orthoclase	6	Glass
Apatite	5	
Fluorite	4	
Calcite	3	Copper penny Fingernail
Gypsum	2	
Talc	1	

Which statement is best supported by the diagram?

- (1) A fingernail will scratch calcite but not gypsum.
  - (2) Calcite will be scratched by a copper penny.
  - (3) The mineral apatite will scratch topaz.
  - (4) A steel file has a hardness of about 7.5.
- 31 The planetary wind belts in the troposphere are primarily caused by the
- (1) Earth's rotation and unequal heating of Earth's surface
  - (2) Earth's revolution and unequal heating of Earth's surface
  - (3) Earth's rotation and Sun's gravitational attraction on Earth's atmosphere
  - (4) Earth's revolution and Sun's gravitational attraction on Earth's atmosphere

32 The map below shows a meandering stream. Points A, B, C, and D represent locations along the stream bottom.

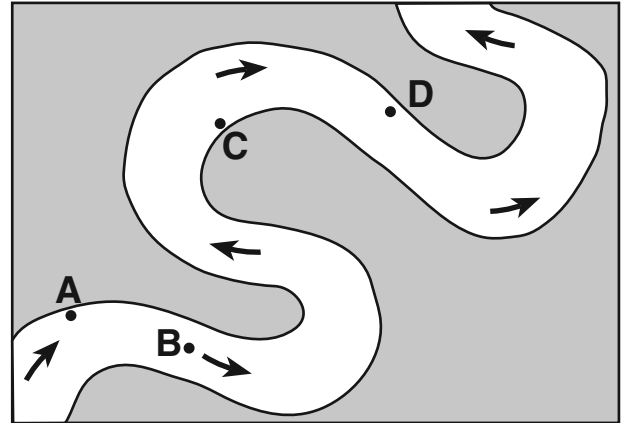

At which location is the greatest amount of sediment most likely being deposited?

- (1) A
  - (2) B
  - (3) C
  - (4) D
- 33 The diagram below shows the surface features of a landscape.

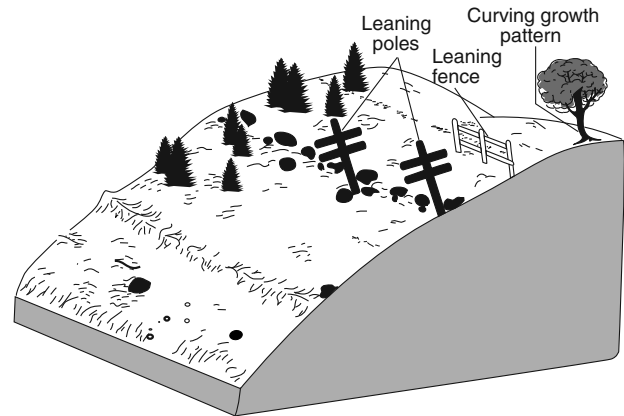

Based on the features shown, which erosional agent had the greatest effect on tree growth and the structures that humans have built on this landscape?

- (1) running water
- (2) moving ice
- (3) prevailing wind
- (4) mass movement

34 The diagram below shows Earth's orbit around the Sun. Locations A, B, C, and D represent Earth on the first day of each season.

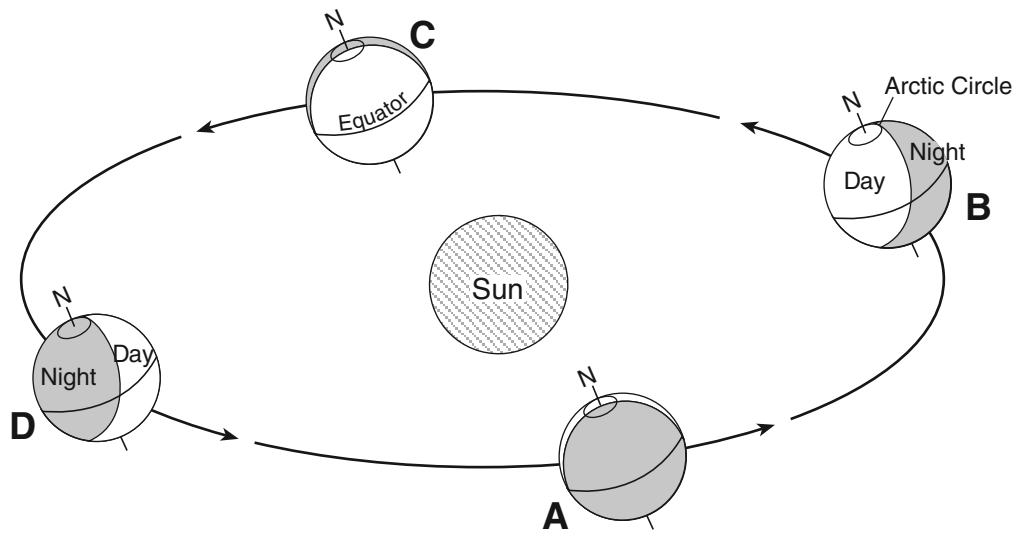

(Not drawn to scale)

Which location represents March 21?

- |       |       |
|-------|-------|
| (1) A | (3) C |
| (2) B | (4) D |

35 The diagram below shows some features in a cave.

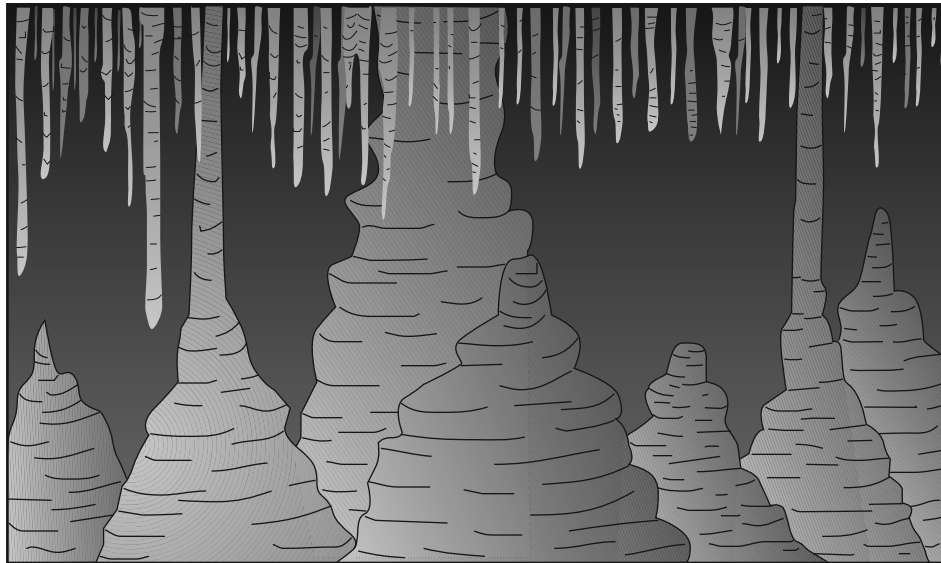

Which type of rock was chemically weathered by acidic groundwater to produce the cave and its features?

- |               |               |
|---------------|---------------|
| (1) siltstone | (3) quartzite |
| (2) basalt    | (4) limestone |

## Part B-1

### Answer all questions in this part.

*Directions (36–50):* For *each* statement or question, write on your separate answer sheet the *number* of the word or expression that, of those given, best completes the statement or answers the question. Some questions may require the use of the *Earth Science Reference Tables*.

Base your answers to questions 36 through 38 on the cross sections below, which represent two bedrock outcrops 15 kilometers apart. The rock layers have been numbered for identification and some contain the index fossil remains shown.

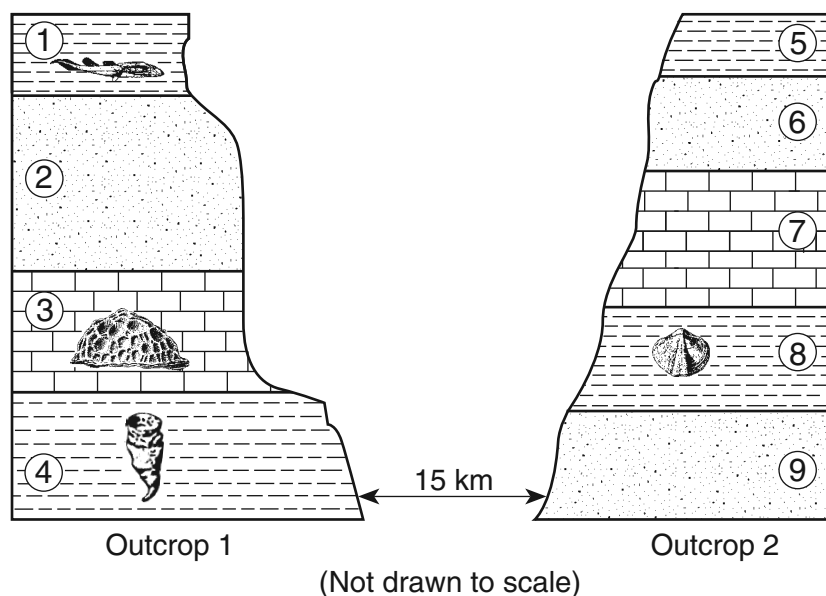

- 36 When these rocks were deposited as sediments, this area was most likely
- (1) under the ocean
  - (2) a desert between high mountains
  - (3) repeatedly covered by lava flows
  - (4) glaciated several times
- 37 Both organisms that formed the fossils found in rock layers 3 and 4
- (1) lived during the same period of geologic time
  - (2) lived in polar regions
  - (3) are members of the same group of organisms
  - (4) are still alive today
- 38 Evidence best indicates that rock layers 4 and 8 were deposited during the same geologic period because both layers
- (1) contain the same index fossil
  - (2) are composed of glacial sediments
  - (3) contain index fossils of the same age
  - (4) are found in the same area

Base your answers to questions 39 through 43 on the passage and map below. The map shows the generalized landscape regions of Vermont.

### Landscape Regions of Vermont

Most of Vermont's landscape regions consist of ancient, weathered mountains that were covered by several ice sheets during the last ice age. When the ice melted, sand, cobbles, and boulders were deposited throughout the state. Vermont is divided into six landscape regions.

- (1) The Vermont Lowlands region has a mild climate, with Lake Champlain moderating its temperature.
- (2) The Green Mountains run the length of Vermont and were formed over 400 million years ago. Most of the bedrock is metamorphic and the region is known for its deposits of talc and asbestos.
- (3) The Taconic Mountains extend into New York State. Slate and marble are commonly mined in this region.
- (4) The Valley of Vermont is a narrow valley between two mountain ranges. Most of the bedrock in the region is limestone and marble.
- (5) The Vermont Piedmont covers the largest area of the state. This region consists of rolling hills and valleys. Granite mining is an important industry.
- (6) The Northeast Highlands is a mountainous region composed of granite bedrock.

### Generalized Landscape Regions of Vermont

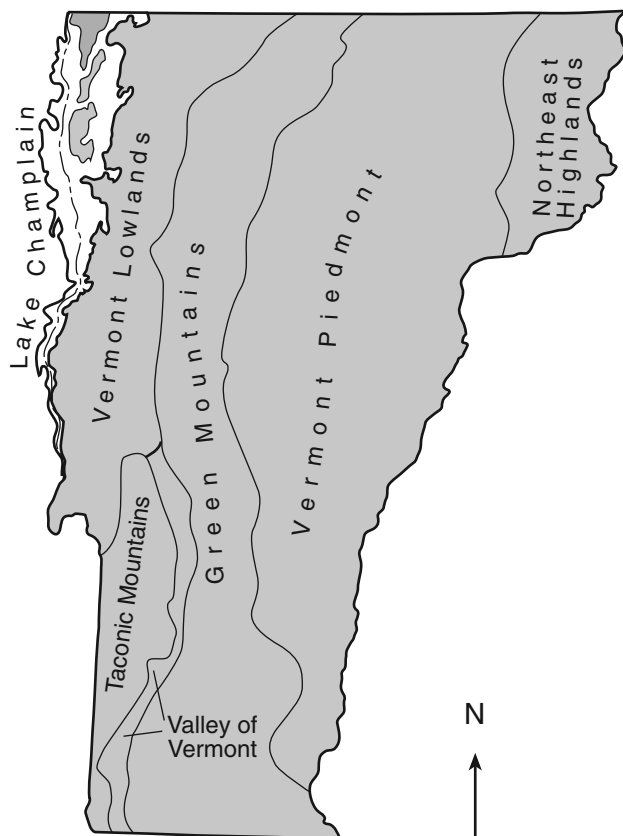

- 39 The classification of landscape regions is primarily based on which factors?
- (1) climate, vegetation, and surface features
  - (2) bedrock type, structure, and elevation
  - (3) state boundaries, streams, and rivers
  - (4) nearness to mountains, lakes, and oceans
- 40 Which Vermont landscape region is a continuation of New York State's Champlain Lowlands landscape?
- (1) Vermont Lowlands
  - (2) Valley of Vermont
  - (3) Taconic Mountains
  - (4) Green Mountains
- 41 During which geologic period did a major orogeny form the Taconic Mountains?
- (1) Cretaceous
  - (2) Permian
  - (3) Devonian
  - (4) Ordovician
- 42 Some of the bedrock in the Green Mountains is actually green in color because of the presence of the mineral chlorite. Which other mineral can cause rocks to appear green?
- (1) sulfur
  - (2) magnetite
  - (3) olivine
  - (4) halite
- 43 Which processes formed the granite that is mined in Vermont?
- (1) compaction and cementation of sediments
  - (2) cooling and solidification of magma
  - (3) uplift and weathering of bedrock
  - (4) application of heat and pressure to shale
-

Base your answers to questions 44 through 46 on the diagram below, which shows Earth in orbit around the Sun, and the Moon in orbit around Earth.  $M_1$ ,  $M_2$ ,  $M_3$ , and  $M_4$  indicate positions of the Moon in its orbit. Letter A indicates a location on Earth's surface.

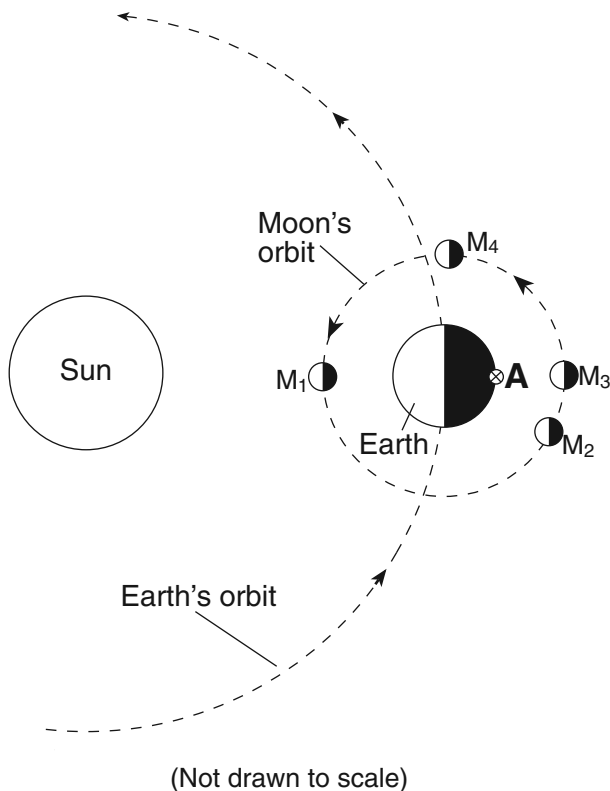

44 An observer at location A on Earth views the Moon when it is at position  $M_3$ . Which phase of the Moon will the observer see?



( 1 )



( 2 )

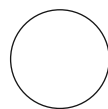

( 3 )



( 4 )

45 At which Moon position could a solar eclipse be seen from Earth?

(1)  $M_1$

(3)  $M_3$

(2)  $M_2$

(4)  $M_4$

46 An observer at location A noticed that the apparent size of the Moon varied slightly from month to month when the Moon was at position  $M_4$  in its orbit. Which statement best explains this variation in the apparent size of the Moon?

(1) The Moon expands in summer and contracts in winter.

(2) The Moon shows complete cycles of phases throughout the year.

(3) The Moon's period of rotation is equal to its period of revolution.

(4) The Moon's distance from Earth varies in a cyclic manner.

Base your answers to questions 47 and 48 on the map and graph below. The map shows two cities, Arica and Rio de Janeiro, located on opposite coasts of South America. Both cities are near sea level. The graph shows the average monthly temperatures for the cities.

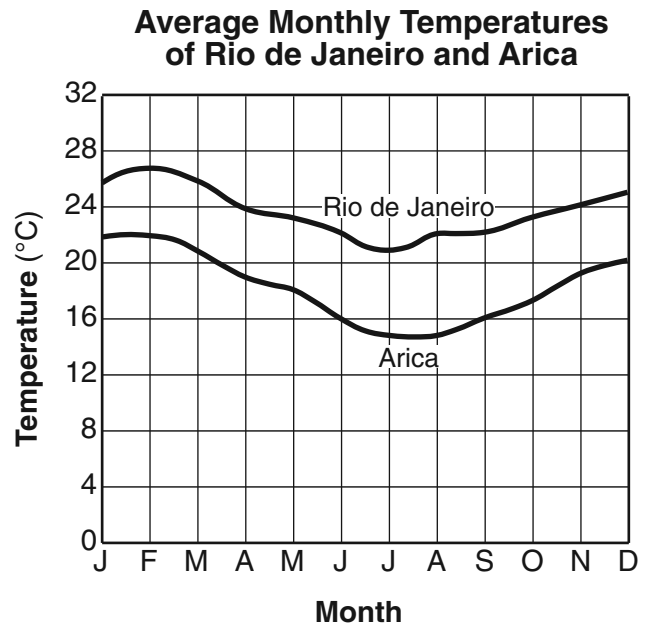
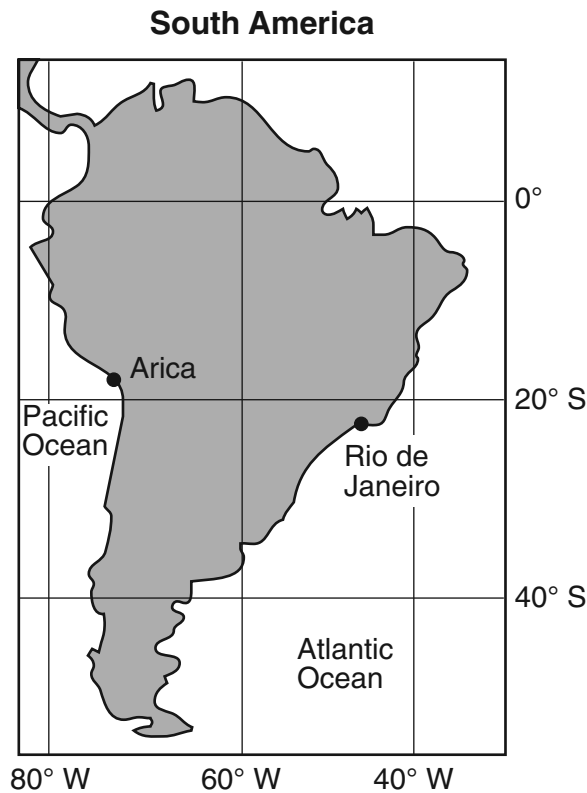

47 Why does Arica have cooler average monthly temperatures than Rio de Janeiro?

- (1) Rio de Janeiro receives insolation at a higher angle than Arica.
- (2) Rio de Janeiro is influenced by a warmer ocean current than Arica.
- (3) Arica is farther north than Rio de Janeiro.
- (4) Arica receives yearly insolation that is less intense than Rio de Janeiro.

48 The summer season at Arica and Rio de Janeiro occurs from approximately

- (1) March 21 through June 20
  - (2) June 21 through September 22
  - (3) September 23 through December 20
  - (4) December 21 through March 20
-

Base your answers to questions 49 and 50 on the graph below, which shows the duration of daylight hours throughout the year for five cities located in the Northern Hemisphere.

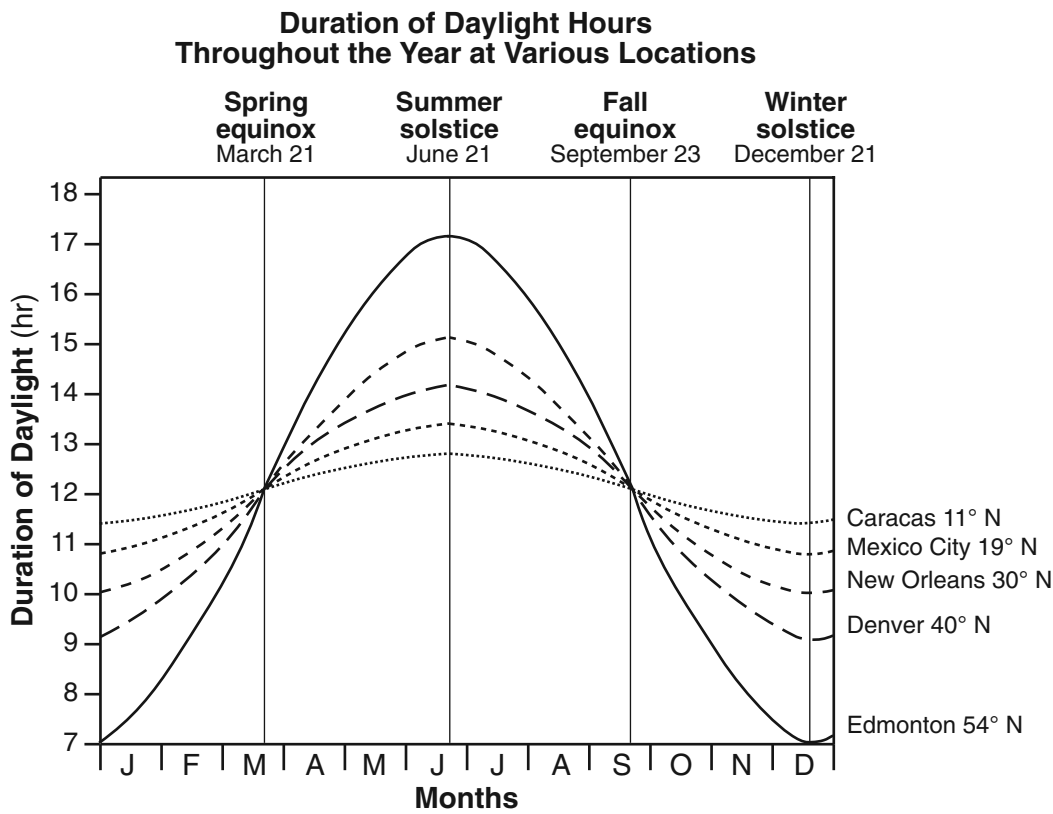

49 Which city experiences the greatest variation in daylight hours during one year?

- (1) Caracas
- (2) Mexico City
- (3) New Orleans
- (4) Edmonton

50 What is the primary reason each city's duration of daylight hours changes throughout the year?

- (1) Earth's axis is tilted  $23.5^\circ$  to the plane of its orbit.
- (2) Earth's rotation rate is  $15^\circ$  per day.
- (3) The cities are located at different longitudes.
- (4) The cities are located at different elevations.



## Part B–2

### Answer all questions in this part.

*Directions (51–65):* Record your answers in the spaces provided in your answer booklet. Some questions may require the use of the *Earth Science Reference Tables*.

Base your answers to questions 51 through 53 on the star chart below, which shows part of the winter sky visible from New York State. Some of the brighter stars are labeled and the constellation Orion is outlined.

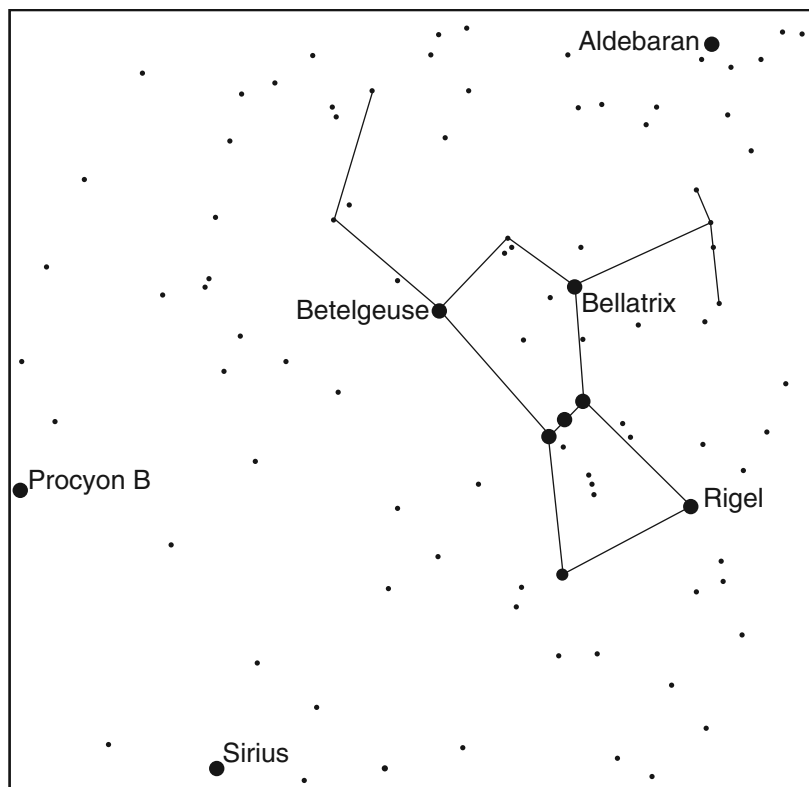

- 51 Identify the color of the star *Bellatrix*, which has a surface temperature of approximately  $21,000^{\circ}\text{C}$ . [1]
- 52 In the space *in your answer booklet*, list the stars, other than *Bellatrix*, found on the chart in order of *decreasing* luminosity. *Rigel*, the most luminous star, has been listed. [1]
- 53 Explain why the constellation Orion is visible at night to an observer in New York State in December and January, but *not* in June and July. [1]
-

Base your answers to questions 54 through 57 on the model and data table shown below. A student constructed a model to demonstrate how water is recycled by natural processes on Earth. The model consisted of a clear plastic tent over a pan containing a bowl of water. The model was sealed so no air could enter or leave the tent. The data table shows the observations recorded when the model was placed in direct sunlight for 60 minutes.

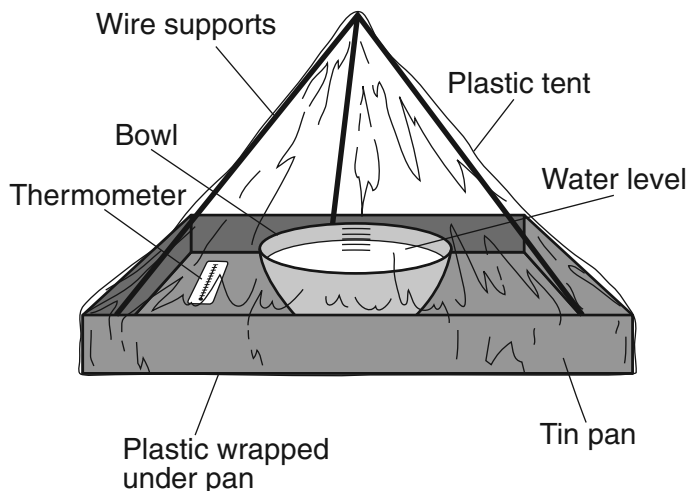

**Data Table**

Time (min)	Observations
0	Water level in bowl = 10 cm Inside walls of the plastic tent are dry. Inside air temperature = 20°C
30	Water level in bowl = 9.9 cm Small drops of water form on the inside walls of the tent. Inside air temperature = 23°C
60	Water level in bowl = 9.8 cm Large drops of water form on the inside walls of the tent. Inside air temperature = 26°C

- 54 Identify the process that caused the water level in the bowl to decrease. [1]
- 55 How much heat energy, in calories per gram, is released as water droplets are formed on the inside walls of the tent? [1]
- 56 If the model is changed and the bowl of water is replaced with a green plant, by which process would the plant supply water vapor to the air inside the tent? [1]

- 57 A student glues a Y-shaped piece of plastic, as shown below, near the top of the inside of the tent and repeats the demonstration. Drops of water are seen dripping from the bottom of the Y after 60 minutes. Which process of the water cycle is represented by the dripping water? [1]

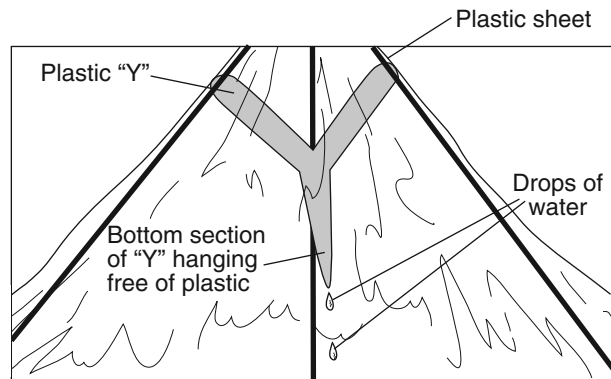

---

Base your answers to questions 58 through 61 on the map provided in your answer booklet, which shows weather station models and some weather variables for a portion of the United States. Selected weather stations are labeled A, B, and C.

- 58 On the map *in your answer booklet*, draw the 50°F isotherm. The isotherm must extend to the edges of the map. [1]
- 59 State the air pressure, in millibars, at weather station A. [1]
- 60 The city represented by weather station B is currently being affected by an air mass that originated over the Gulf of Mexico. What is the two-letter air-mass symbol used to represent this air mass? [1]
- 61 Which weather condition is indicated by the present weather symbol at station C? [1]
-

Base your answers to questions 62 through 65 on the map below and the cross sections on the next page. The map shows a portion of the Indian Ocean and surrounding landmasses. The location of the epicenter of a large undersea earthquake that occurred on December 26, 2004, is shown by an **X**. The isolines surrounding the epicenter show the approximate location of the first tsunami wave produced by this earthquake in half-hour intervals after the initial earthquake. Cross sections I and II illustrate how this undersea earthquake produced the tsunami. Cross section III shows the tsunami approaching a shoreline. The cross sections are not drawn to scale.

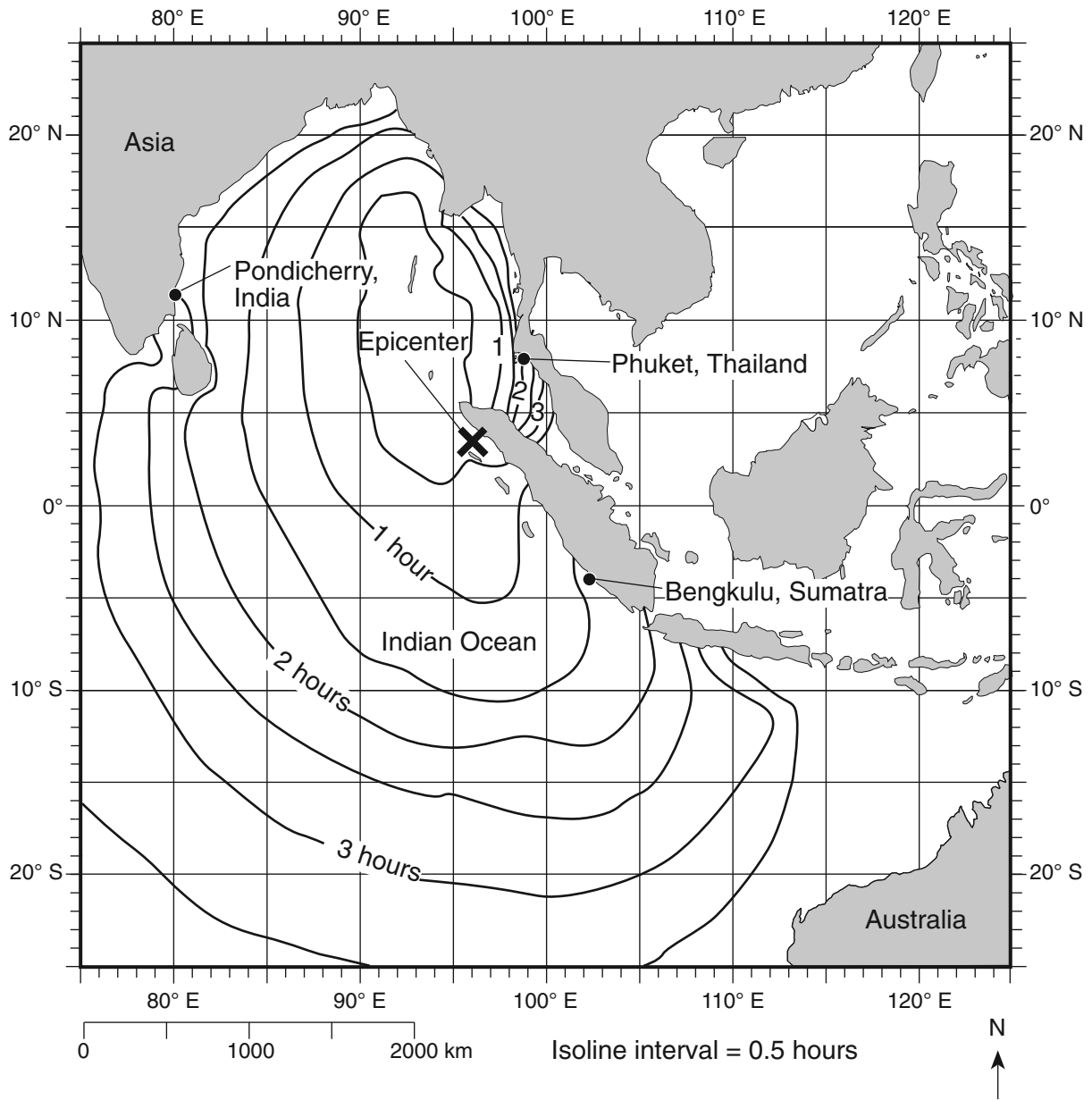

### Cross section I

Tectonic setting before the earthquake occurred

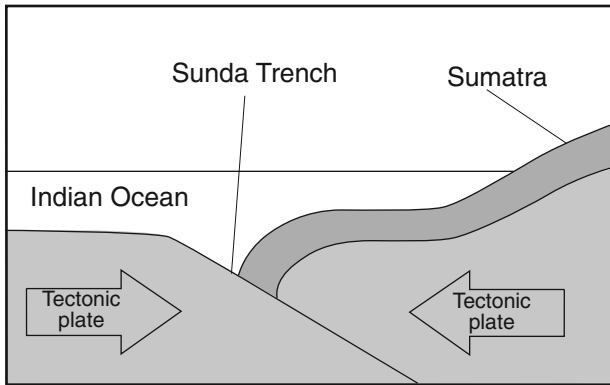

### Cross section II

Chain reaction caused by tectonic plate motion and the resulting movement of the seafloor

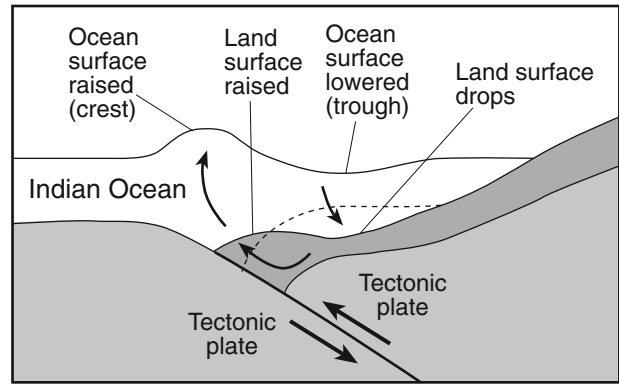

### Cross section III

As the tsunami moves into shallow waters and approaches land, the trough reaches land before the first wave crest hits land.

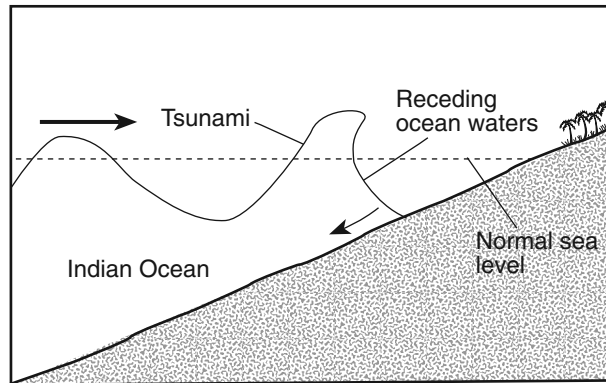

- 62 According to the map, how long after this earthquake did the first tsunami wave arrive at Bengkulu, Sumatra? [1]
  - 63 State the latitude and longitude of the epicenter of this earthquake. Include the units and compass directions in your answer. [1]
  - 64 Identify the overriding tectonic plate at the convergent plate boundary where this earthquake occurred. [1]
  - 65 Based on cross section III, describe the ocean water-level change at the shoreline that people observed just before the first tsunami wave approached the shore. [1]
-

## Part C

### Answer all questions in this part.

*Directions (66–85):* Record your answers in the spaces provided in your answer booklet. Some questions may require the use of the *Earth Science Reference Tables*.

Base your answers to questions 66 through 69 on the map below, which shows a portion of the United States where 148 tornadoes occurred during a 24-hour period in April 1974. The paths of the tornadoes are shown.

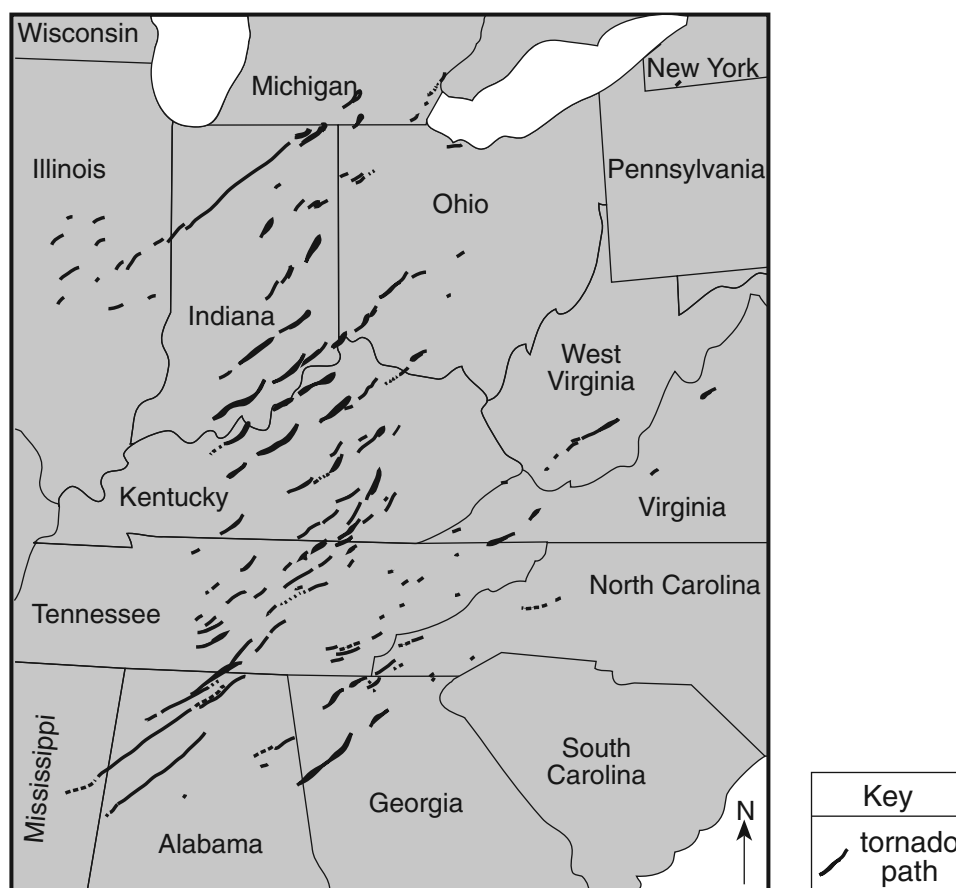

- 66 Explain why all the tornadoes moved toward the northeast. [1]
- 67 Describe the air movement most likely found within these tornadoes. [1]
- 68 A school receives a tornado warning. Describe *one* emergency action that a teacher and the students in a classroom should immediately take to protect themselves from injury. [1]
- 69 Most of these tornadoes occurred with thunderstorms along cold fronts. Identify the water cycle process that forms clouds along cold fronts. [1]

Base your answers to questions 70 and 71 on the data table below, which shows the diameters of three particles, *A*, *B*, and *C*, made of the same uniform material. These particles were carried by a stream into a lake.

**Data Table**

<b>Particle</b>	<b>Particle Diameter (cm)</b>
A	0.5
B	1.0
C	0.1

70 The cross-sectional diagram *in your answer booklet* shows the stream entering the lake. On the diagram, indicate the expected pattern of deposition of the three particles by placing the letters *A*, *B*, and *C* in the appropriate boxes along the lake bottom. [1]

71 Explain why the particles are deposited after the stream enters the lake. [1]

---

Base your answers to questions 72 through 76 on the diagram in your answer booklet, which represents a model of the sky above a vertical post in New York State. The diagram shows the position of the Sun at solar noon on September 23 and the position of *Polaris* above the horizon.

72 On the diagram *in your answer booklet*, draw the apparent path of the Sun across the sky on September 23 from sunrise to sunset. [1]

73 On the diagram *in your answer booklet*, draw the shadow of the vertical post as it would appear at solar noon on September 23. [1]

74 Place an **X** on the diagram *in your answer booklet* to indicate the altitude of the Sun at solar noon on June 21. [1]

75 How many degrees will the Sun appear to move across the sky from 1 p.m. to 3 p.m. on June 21? [1]

76 At which latitude is this vertical post located? Include the unit and compass direction in your answer. [1]

---

Base your answers to questions 77 through 81 on the passage and map below and the tide table on the next page. The map shows the tidal range (the difference between the highest and lowest tides) in meters for the Bay of Fundy, Chignecto Bay, and the Minas Basin. The table shows the times of high and low tides for Hopewell Cape for August 21 and 22, 2005.

### The Bay of Fundy has the Highest Tides on Earth

The unique shape of the Bay of Fundy contributes to the extremely high ocean tides experienced there. Frequently described as funnel shaped, the bay gradually becomes more narrow and shallow to the northeast where it splits to form Chignecto Bay and the Minas Basin. The highest tides of the Bay of Fundy are found within these fingers of the bay and are caused by the incoming tides encountering seaward-moving river currents as the bay narrows. The tide height is also affected by the amount of time it takes for high tide to flood the bay. This time is nearly identical from one high tide to the next.

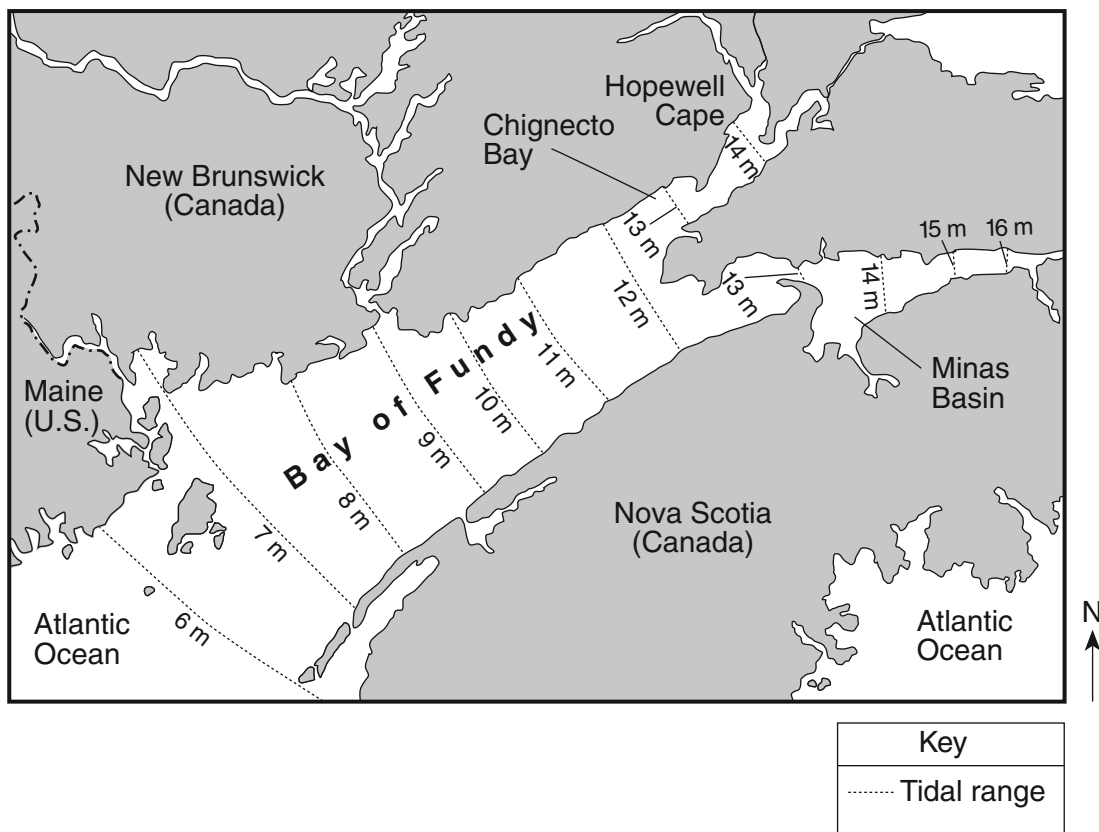



**Hopewell Cape  
Tide Table, August 2005**

<b>Date</b>	<b>Time</b>	<b>Tide Height (m)</b>
21	1:28 a.m.	14.0
21	8:03 a.m.	-0.1
21	1:54 p.m.	13.7
21	8:26 p.m.	0.0
22	2:20 a.m.	14.0
22	8:52 a.m.	-0.2
22	2:46 p.m.	13.8
22	9:16 p.m.	0.0

- 77 Describe *two* characteristics of the Bay of Fundy that cause the extremely high tides to occur at Hopewell Cape. [1]
- 78 On the grid *in your answer booklet*, plot with an **X** the height of the water for *each* time listed on the tide table. Connect the centers of the **X**s with a smooth, curved line. [1]
- 79 Using the tide table for Hopewell Cape, calculate the time difference between two consecutive high tides. Express your answer to the *nearest minute*. [1]
- 80 The diagram *in your answer booklet* shows an observer standing near a measuring stick at the 0-meter tide height location at Hopewell Cape. The diagram is drawn to a scale of 1 centimeter equals 2 meters. On the measuring stick, place an **X** to show the highest tide level shown on the tide table for August 21. [1]
- 81 The diagram *in your answer booklet* shows the Moon's orbital path and Earth as viewed from space. The points on Earth indicate two locations where high ocean tides are occurring. Place an **X** on the Moon's orbital path to show where the Moon could be located when these high tides are produced. [1]
-

Base your answers to questions 82 through 85 on the map and passage below. The map shows the outlines and ages of several calderas created as a result of volcanic activity over the last 16 million years as the North American Plate moved over the Yellowstone Hot Spot. *A* and *B* represent locations within the calderas.

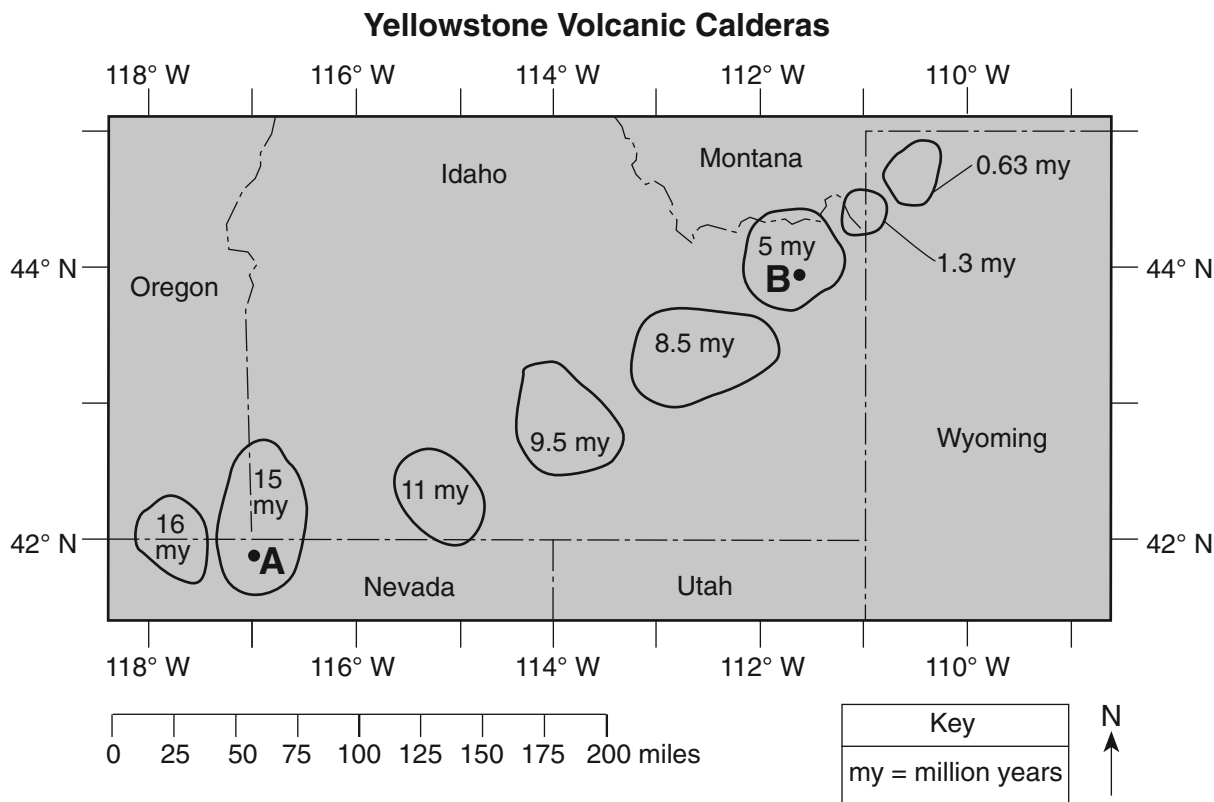

### The Yellowstone Hot Spot

The Yellowstone Hot Spot has interacted with the North American Plate, causing widespread outpourings of basalt that buried about 200,000 square miles under layers of lava flows that are a half mile or more thick. Some of the basaltic magma produced by the hot spot accumulates near the base of the plate, where it melts the crust above. The melted crust, in turn, rises closer to the surface to form large reservoirs of potentially explosive rhyolite magma. Catastrophic eruptions have partly emptied some of these reservoirs, causing their roofs to collapse. The resulting craters, some of which are more than 30 miles across, are known as volcanic calderas.

- 82 Describe the texture and color of the basalt produced by the Yellowstone Hot Spot. [1]
- 83 Identify *two* minerals found in the igneous rock that is produced from the explosive rhyolite magma. [1]
- 84 Based on the age pattern of the calderas shown on the map, in which compass direction has the North American Plate moved during the last 16 million years? [1]
- 85 Calculate, in miles per million years, the rate at which the North American Plate has moved over the Yellowstone Hot Spot between point *A* and point *B*. [1]

Tear Here

The University of the State of New York

REGENTS HIGH SCHOOL EXAMINATION

PHYSICAL SETTING  
EARTH SCIENCE

Wednesday, August 13, 2008 — 12:30 to 3:30 p.m., only

ANSWER SHEET

Student ..... Sex:  Male  Female Grade .....

Teacher ..... School .....

Record your answers to Part A and Part B-1 on this answer sheet.

Part A

- 1 ..... 13 ..... 25 .....
- 2 ..... 14 ..... 26 .....
- 3 ..... 15 ..... 27 .....
- 4 ..... 16 ..... 28 .....
- 5 ..... 17 ..... 29 .....
- 6 ..... 18 ..... 30 .....
- 7 ..... 19 ..... 31 .....
- 8 ..... 20 ..... 32 .....
- 9 ..... 21 ..... 33 .....
- 10 ..... 22 ..... 34 .....
- 11 ..... 23 ..... 35 .....
- 12 ..... 24 .....

Part A Score

Part B-1

- 36 ..... 44 .....
- 37 ..... 45 .....
- 38 ..... 46 .....
- 39 ..... 47 .....
- 40 ..... 48 .....
- 41 ..... 49 .....
- 42 ..... 50 .....
- 43 .....

Part B-1 Score

Write your answers to Part B-2 and Part C in your answer booklet.

The declaration below must be signed when you have completed the examination.

I do hereby affirm, at the close of this examination, that I had no unlawful knowledge of the questions or answers prior to the examination and that I have neither given nor received assistance in answering any of the questions during the examination.

Signature

Tear Here

**PHYSICAL SETTING  
 EARTH SCIENCE**

Wednesday, August 13, 2008 — 12:30 to 3:30 p.m., only

**ANSWER BOOKLET**

Student ..... Sex:  Male  
 Female  
 Teacher .....  
 School ..... Grade .....

Answer all questions in Part B-2 and Part C. Record your answers in this booklet.

<input type="text"/>		<b>Performance Test Score</b> (Maximum Score: 16)
.....		
<b>Part</b>	<b>Maximum Score</b>	<b>Student's Score</b>
A	35	
B-1	15	
B-2	15	
C	20	
<b>Total Written Test Score</b> (Maximum Raw Score: 85)		<input type="text"/>
<b>Final Score</b> (from conversion chart)		<input type="text"/>
<b>Raters' Initials:</b>		
Rater 1 ..... Rater 2 .....		

<b>Part B-2</b>		<b>For Raters Only</b>
51 _____		51 <input type="text"/>
52 Most luminous (1) <u>Rigel</u>		
↓	(2) _____	
	(3) _____	52 <input type="text"/>
	(4) _____	
Least luminous (5) _____		
53 _____		53 <input type="text"/>
_____		
54 _____		54 <input type="text"/>
55 _____ calories per gram		55 <input type="text"/>
56 _____		56 <input type="text"/>
57 _____		57 <input type="text"/>

58

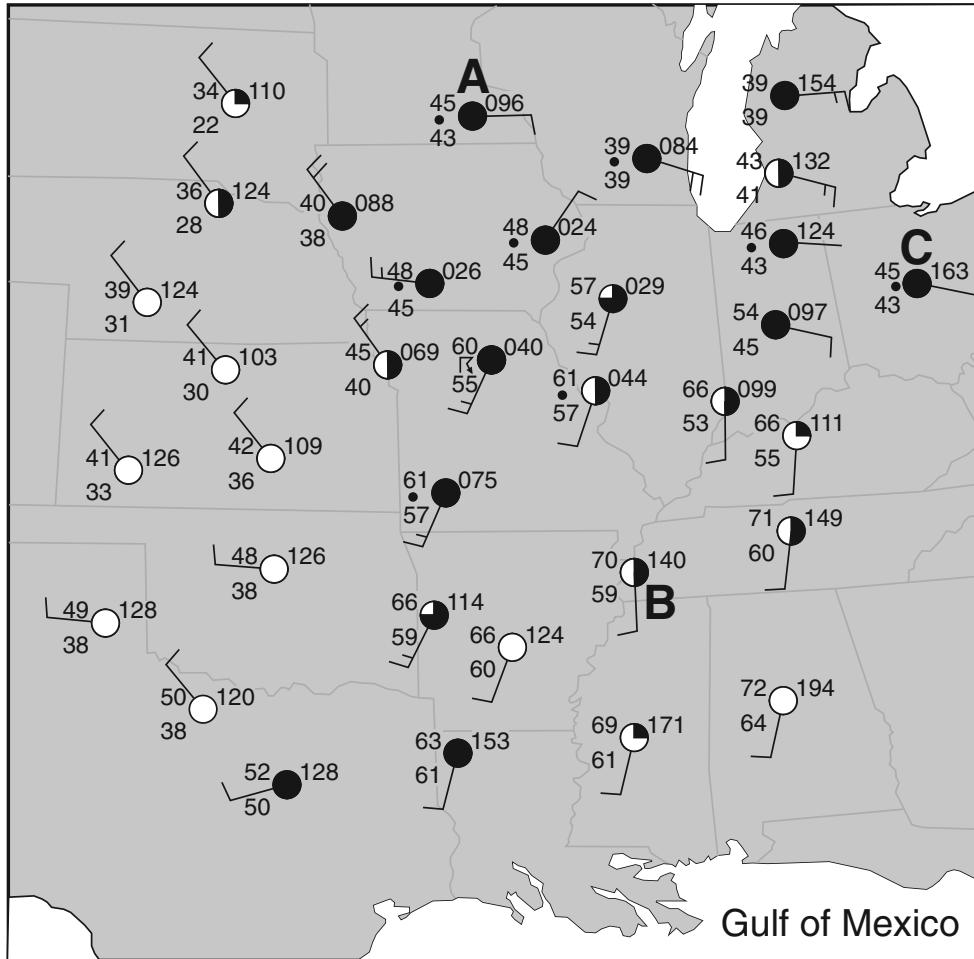

58



59 \_\_\_\_\_ mb

59



60 \_\_\_\_\_

60



61 \_\_\_\_\_

61



**For Raters  
Only**

62 \_\_\_\_\_ **hr** \_\_\_\_\_ **min**

62

63 Latitude: \_\_\_\_\_

63

Longitude: \_\_\_\_\_

64 \_\_\_\_\_ **Plate**

64

65 \_\_\_\_\_

65

\_\_\_\_\_

\_\_\_\_\_

**Total Score for  
Part B-2**

Part C

For Raters Only

66

---

---

66

67

---

---

67

68

---

---

68

69

---

---

69

70

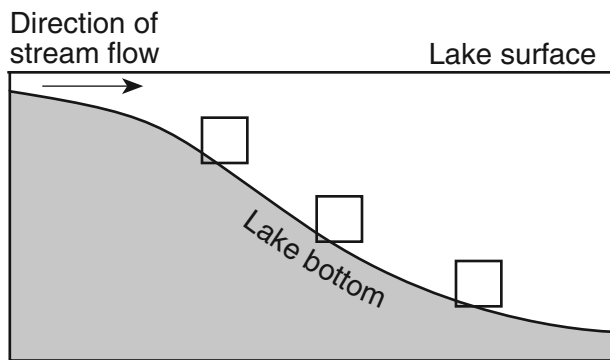

70

71

---

---

71

For Raters Only

72-74

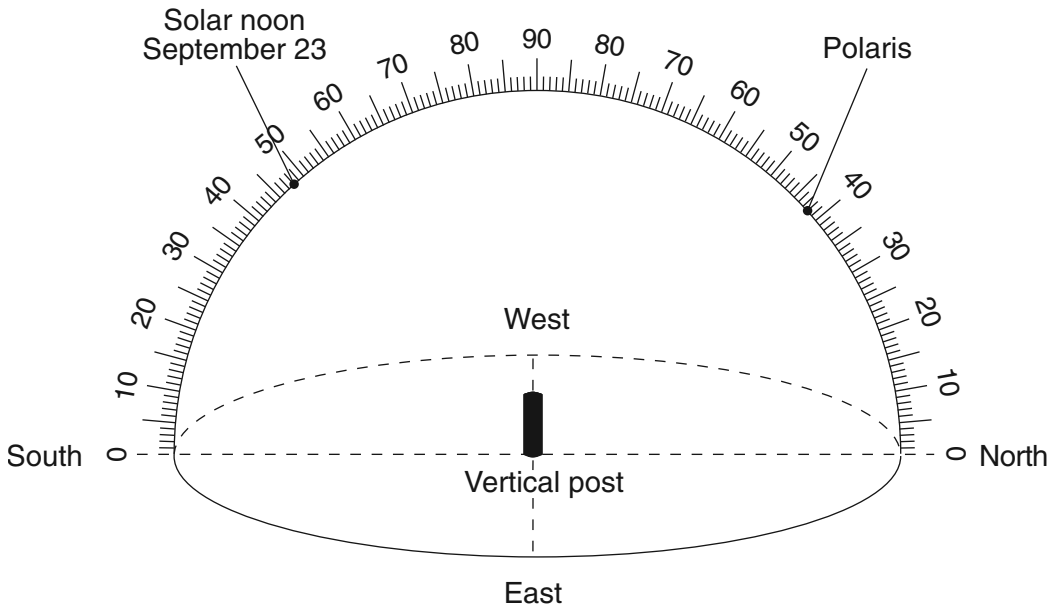

72

73

74

75

\_\_\_\_\_

75

76

\_\_\_\_\_

76

77 Characteristic 1:

\_\_\_\_\_

77

Characteristic 2:

\_\_\_\_\_



For Raters Only

### Hopewell Cape Tides

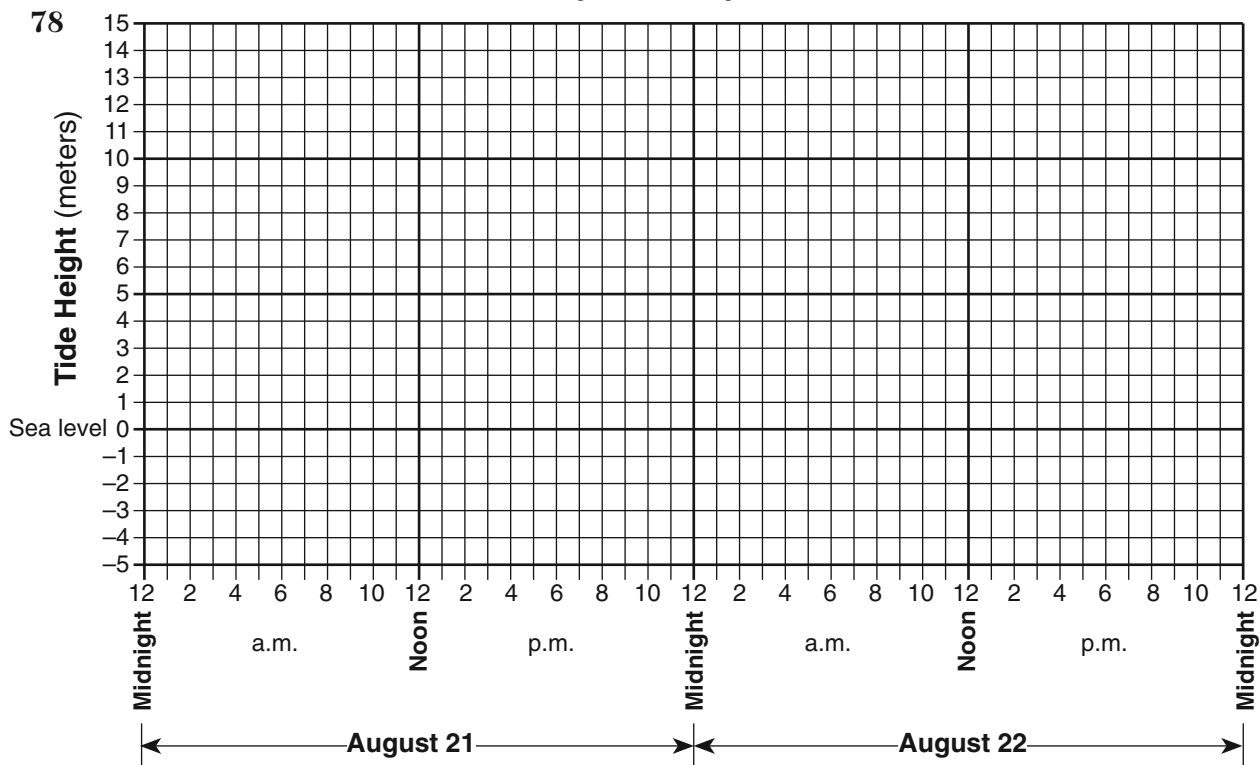

78

79 \_\_\_\_\_ hr \_\_\_\_\_ min

79

80

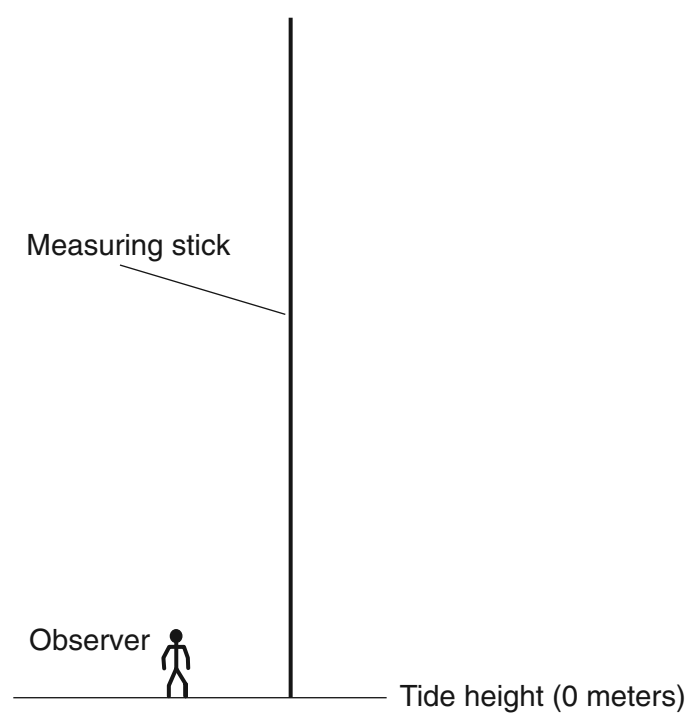

80

(Drawn to scale)  
1 cm = 2 m

**For Raters Only**

81

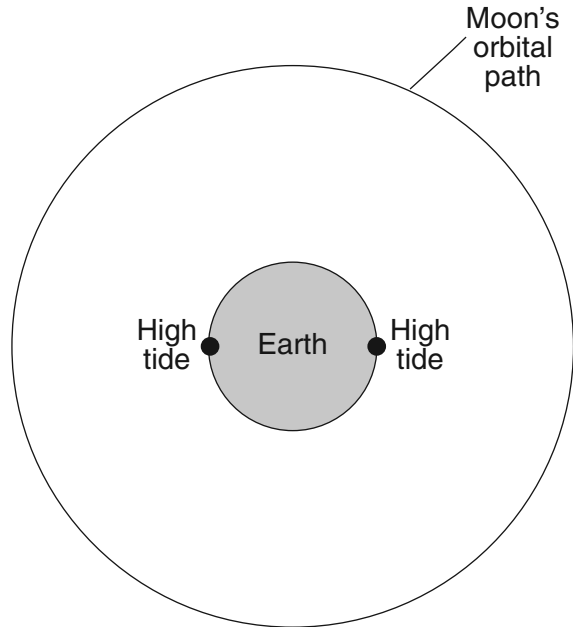

(Not drawn to scale)

81

82 Texture: \_\_\_\_\_

82

Color: \_\_\_\_\_

83 (1) \_\_\_\_\_

83

(2) \_\_\_\_\_

84 \_\_\_\_\_

84

85 \_\_\_\_\_ miles per million years

85

**Total Score  
for Part C**

# FOR TEACHERS ONLY

The University of the State of New York  
REGENTS HIGH SCHOOL EXAMINATION

## PS-ES PHYSICAL SETTING/EARTH SCIENCE

Wednesday, August 13, 2008 — 12:30 to 3:30 p.m., only

### SCORING KEY AND RATING GUIDE

**Directions to the Teacher:**

Refer to the directions on page 3 before rating student papers.

Updated information regarding the rating of this examination may be posted on the New York State Education Department's web site during the rating period. Check this web site <http://www.emsc.nysed.gov/osa/> and select the link "Examination Scoring Information" for any recently posted information regarding this examination. This site should be checked before the rating process for this examination begins and several times throughout the Regents examination period.

**Part A and Part B-1**

Allow 1 credit for each correct response.

Part A			Part B-1	
1 . . . . . <b>1</b> . . . . .	13 . . . . . <b>3</b> . . . . .	25 . . . . . <b>2</b> . . . . .	36 . . . . . <b>1</b> . . . . .	44 . . . . . <b>3</b> . . . . .
2 . . . . . <b>3</b> . . . . .	14 . . . . . <b>3</b> . . . . .	26 . . . . . <b>1</b> . . . . .	37 . . . . . <b>3</b> . . . . .	45 . . . . . <b>1</b> . . . . .
3 . . . . . <b>3</b> . . . . .	15 . . . . . <b>1</b> . . . . .	27 . . . . . <b>2</b> . . . . .	38 . . . . . <b>3</b> . . . . .	46 . . . . . <b>4</b> . . . . .
4 . . . . . <b>2</b> . . . . .	16 . . . . . <b>3</b> . . . . .	28 . . . . . <b>4</b> . . . . .	39 . . . . . <b>2</b> . . . . .	47 . . . . . <b>2</b> . . . . .
5 . . . . . <b>3</b> . . . . .	17 . . . . . <b>1</b> . . . . .	29 . . . . . <b>4</b> . . . . .	40 . . . . . <b>1</b> . . . . .	48 . . . . . <b>4</b> . . . . .
6 . . . . . <b>4</b> . . . . .	18 . . . . . <b>2</b> . . . . .	30 . . . . . <b>2</b> . . . . .	41 . . . . . <b>4</b> . . . . .	49 . . . . . <b>4</b> . . . . .
7 . . . . . <b>4</b> . . . . .	19 . . . . . <b>3</b> . . . . .	31 . . . . . <b>1</b> . . . . .	42 . . . . . <b>3</b> . . . . .	50 . . . . . <b>1</b> . . . . .
8 . . . . . <b>1</b> . . . . .	20 . . . . . <b>4</b> . . . . .	32 . . . . . <b>3</b> . . . . .	43 . . . . . <b>2</b> . . . . .	
9 . . . . . <b>3</b> . . . . .	21 . . . . . <b>4</b> . . . . .	33 . . . . . <b>4</b> . . . . .		
10 . . . . . <b>2</b> . . . . .	22 . . . . . <b>3</b> . . . . .	34 . . . . . <b>1</b> . . . . .		
11 . . . . . <b>3</b> . . . . .	23 . . . . . <b>2</b> . . . . .	35 . . . . . <b>4</b> . . . . .		
12 . . . . . <b>4</b> . . . . .	24 . . . . . <b>1</b> . . . . .			

**Directions to the Teacher**

Follow the procedures below for scoring student answer papers for the Physical Setting/Earth Science examination. Additional information about scoring is provided in the publication *Information Booklet for Scoring Regents Examinations in the Sciences*.

Use only *red* ink or *red* pencil in rating Regents papers. Do *not* correct the student's work by making insertions or changes of any kind.

On the detachable answer sheet for Part A and Part B–1, indicate by means of a check mark each incorrect or omitted answer. In the box provided at the end of each part, record the number of questions the student answered correctly for that part.

At least two science teachers must participate in the scoring of each student's responses to the Part B–2 and Part C open-ended questions. Each of these teachers should be responsible for scoring a selected number of the open-ended questions on each answer paper. No one teacher is to score all the open-ended questions on a student's answer paper.

Students' responses must be scored strictly according to the Scoring Key and Rating Guide. For open-ended questions, credit may be allowed for responses other than those given in the rating guide if the response is a scientifically accurate answer to the question and demonstrates adequate knowledge as indicated by the examples in the rating guide. In the student's answer booklet, record the number of credits earned for each answer in the box printed to the right of the answer lines or spaces for that question.

Fractional credit is *not* allowed. Only whole-number credit may be given to a response. Units need not be given when the wording of the questions allows such omissions.

Raters should enter the scores earned for Part A, Part B–1, Part B–2, and Part C on the appropriate lines in the box printed on the answer booklet and then should add these four scores and enter the total in the box labeled "Total Written Test Score." The student's score for the Earth Science Performance Test should be entered in the space provided. Then, the student's raw scores on the performance test and written test should be converted to a scaled score by using the conversion chart that will be posted on the Department's web site <http://www.emsc.nysed.gov/osa/> on Wednesday, August 13, 2008. The student's scaled score should be entered in the labeled box on the student's answer booklet. The scaled score is the student's final examination score.

All student answer papers that receive a scaled score of 60 through 64 **must** be scored a second time. For the second scoring, a different committee of teachers may score the student's paper or the original committee may score the paper, except that no teacher may score the same open-ended questions that he/she scored in the first rating of the paper. The school principal is responsible for assuring that the student's final examination score is based on a fair, accurate, and reliable scoring of the student's answer paper.

Because scaled scores corresponding to raw scores in the conversion chart may change from one examination to another, it is crucial that for each administration, the conversion chart provided for that administration be used to determine the student's final score.

**Part B–2**

**Allow a total of 15 credits for this part. The student must answer all questions in this part.**

**51** [1] Allow 1 credit for blue.

**52** [1] Allow 1 credit for a list in the order shown.

Most luminous	(1)	<i>Rigel</i>
↓	(2)	<i>Betelgeuse</i>
	(3)	<i>Aldebaran</i>
	(4)	<i>Sirius</i>
Least luminous	(5)	<i>Procyon B</i>

**53** [1] Allow 1 credit. Acceptable responses include, but are not limited to:

- Earth is revolving around the Sun.
- Different regions of space are visible at night from different positions in Earth’s orbit.

**54** [1] Allow 1 credit for evaporation.

**55** [1] Allow 1 credit for 540 calories per gram.

**56** [1] Allow 1 credit for transpiration.

**57** [1] Allow 1 credit. Acceptable responses include, but are not limited to:

- precipitation
- rain

- 58** [1] Allow 1 credit for a correctly drawn 50°F isotherm. An example of a 50°F isotherm is shown on the map below. The isotherm does *not* have to be labeled but must extend to the edges of the map. If more than one isotherm is drawn, all must be correct to receive credit.

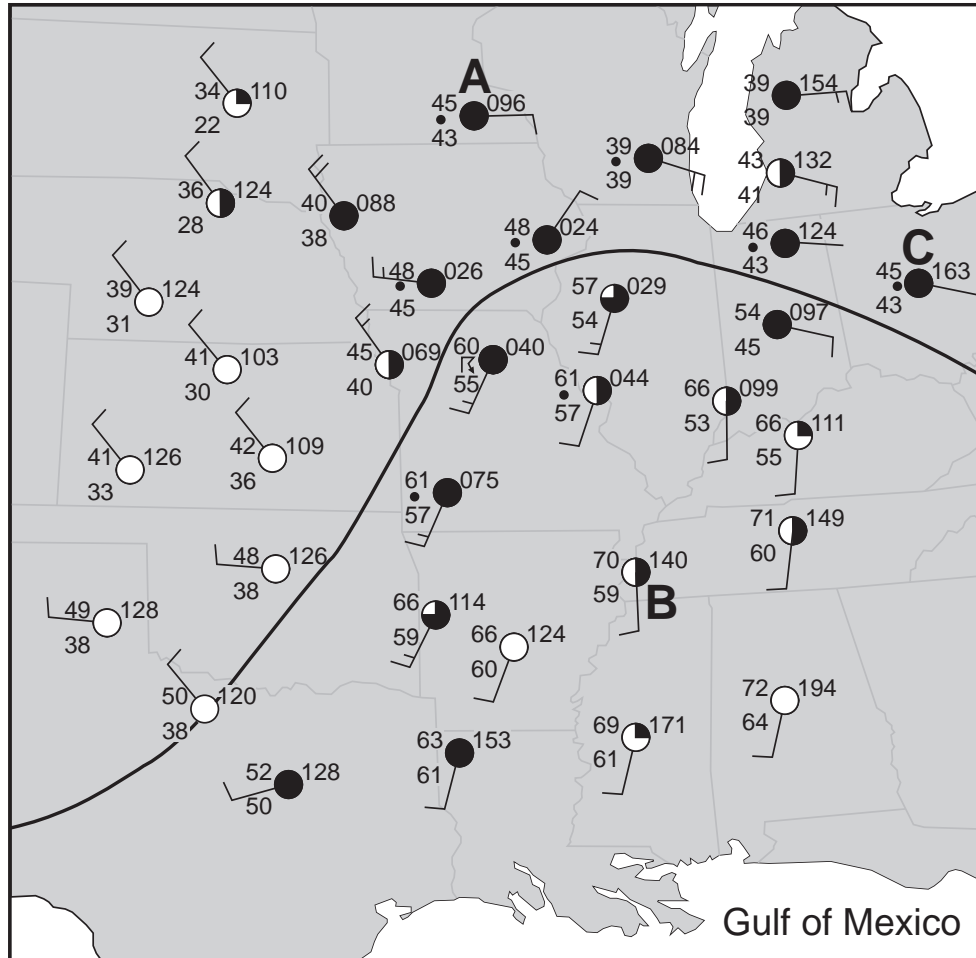

- 59** [1] Allow 1 credit for 1009.6 mb.
- 60** [1] Allow 1 credit for the correct two-letter symbol mT *or* MT. Do *not* accept a response where letters are reversed, such as Tm.
- 61** [1] Allow 1 credit for rain.

- 62** [1] Allow 1 credit for any value from 1 hr 32 min to 1 hr 42 min.
- 63** [1] Allow 1 credit if latitude, longitude, units, and compass directions are all correct.
- Latitude: Allow credit for any value from 3.0° to 4.0° N.
  - Longitude: Allow credit for any value from 95.5° to 96.5° E.
- 64** [1] Allow 1 credit for Eurasian Plate.
- 65** [1] Allow 1 credit. Acceptable responses include, but are not limited to:
- The ocean water receded.
  - The water level dropped.

**Part C**

**Allow a total of 20 credits for this part. The student must answer all questions in this part.**

- 66** [1] Allow 1 credit. Acceptable responses include, but are not limited to:
- The tornadoes are located within the SW wind belt.
  - The planetary winds moved them toward the northeast.
  - The tornadoes are moving this way because of the prevailing winds.

- 67** [1] Allow 1 credit. Acceptable responses include, but are not limited to:
- counterclockwise
  - toward the center
  - upward air movement

- 68** [1] Allow 1 credit. Acceptable responses include, but are not limited to:
- go to the structurally strongest area in the school nearest your location
  - go to the lowest level in the school
  - go to an interior location with no windows
  - go under a desk or table

- 69** [1] Allow 1 credit. Acceptable responses include, but are not limited to:
- condensation (gas to liquid)
  - deposition (gas to solid)

- 70** [1] Allow 1 credit for the correct sequence as shown below.

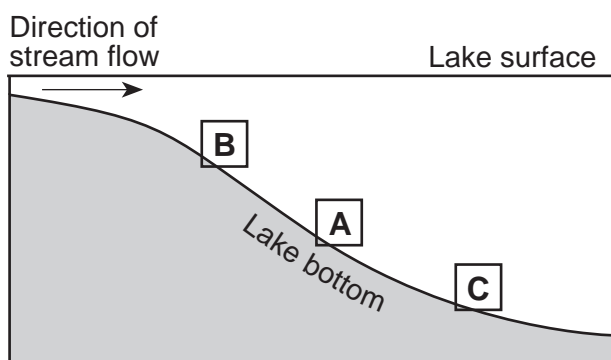



- 71 [1] Allow 1 credit. Acceptable responses include, but are not limited to:
- The water velocity decreases.
  - The particles slow down.
- 72 [1] Allow 1 credit for drawing the apparent path of the Sun from due east to due west and passing through the given solar noon position.
- 73 [1] Allow 1 credit for drawing a shadow that extends due north. Allow credit even if the shadow length is incorrect.
- 74 [1] Allow 1 credit for any altitude of the Sun from  $70.5^\circ$  to  $72.5^\circ$ .

**Example of a 3-credit response for questions 72 through 74:**

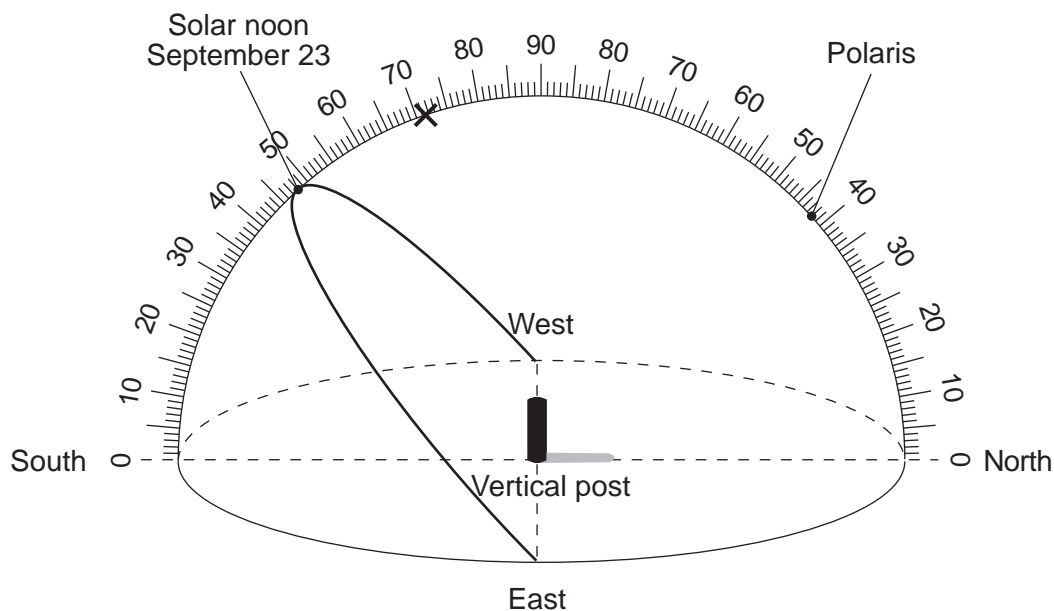

- 75 [1] Allow 1 credit for  $30^\circ$ .
- 76 [1] Allow 1 credit for  $42^\circ$  N.

- 77 [1] Allow 1 credit for *two* correct responses. Acceptable responses include, but are not limited to:
- shape of the bay
  - gradual narrowing
  - shallowing of the bay
  - the time it takes to flood the bay
  - seaward-moving river currents

- 78 [1] Allow 1 credit if the center of seven or eight **X**s are correctly plotted within the circles shown and connected with a line that passes through the circles.

**Example of a 1-credit response:**

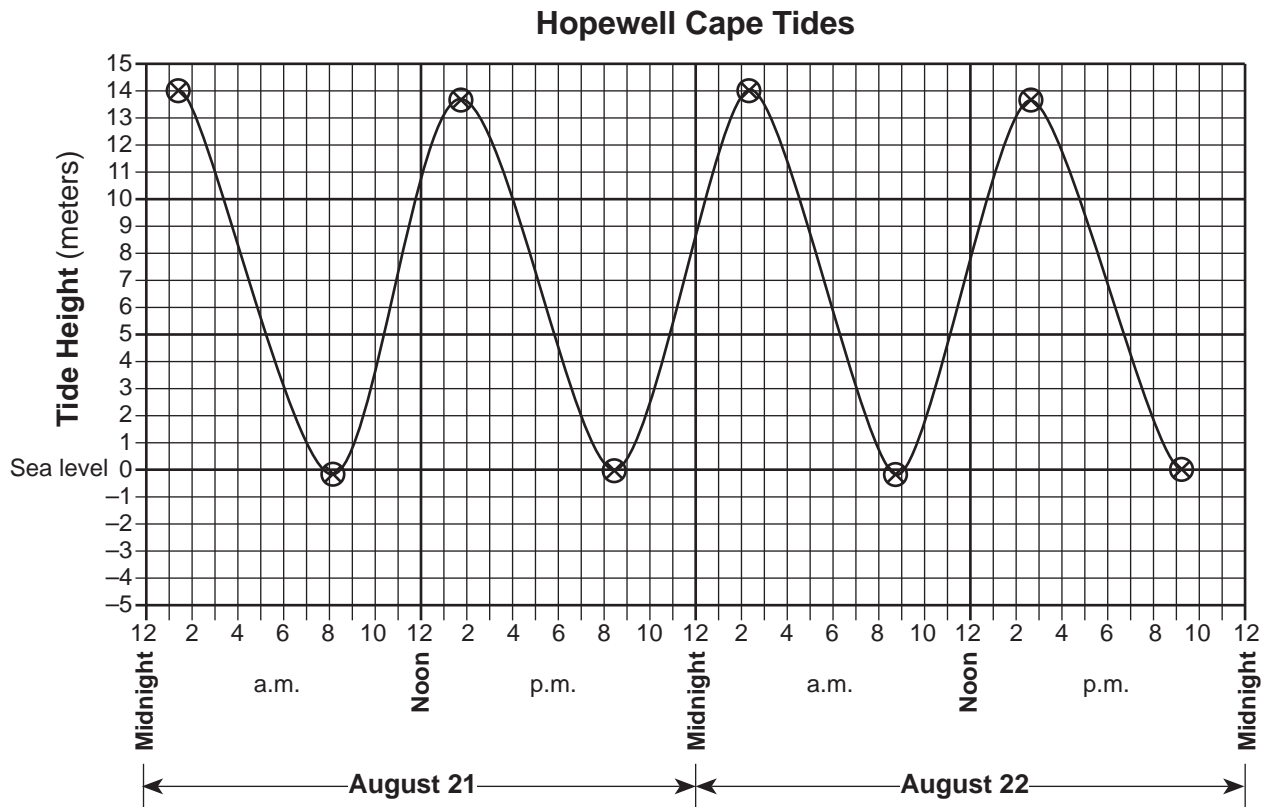

- 79 [1] Allow 1 credit for 12 hr 26 min.

80 [1] Allow 1 credit if the center of the **X** is within the brackets shown on the diagram below.

**Example of a 1-credit response:**

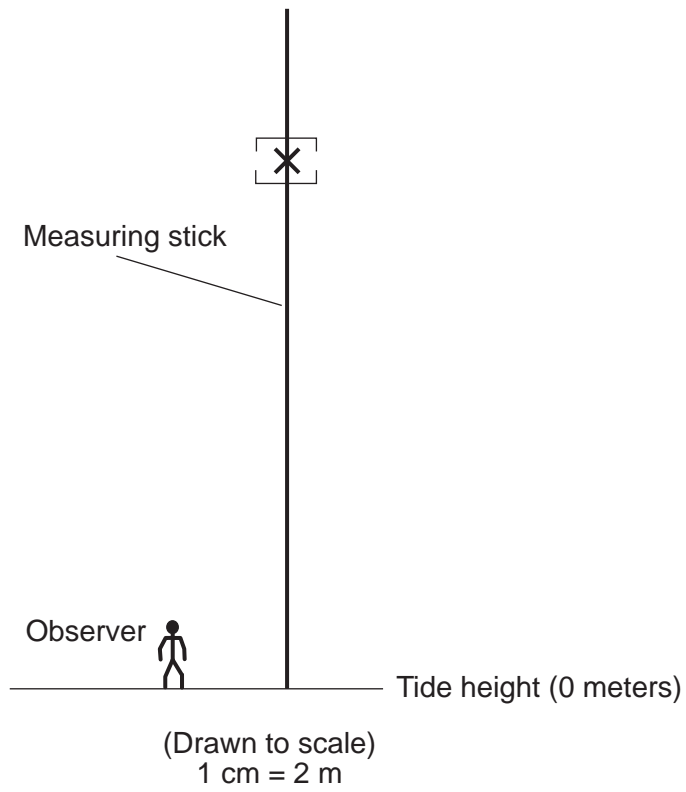

- 81 [1] Allow 1 credit for an **X** that has been placed at either Moon location shown below. The center of the **X** must be within either circle shown.

**Example of a 1-credit response:**

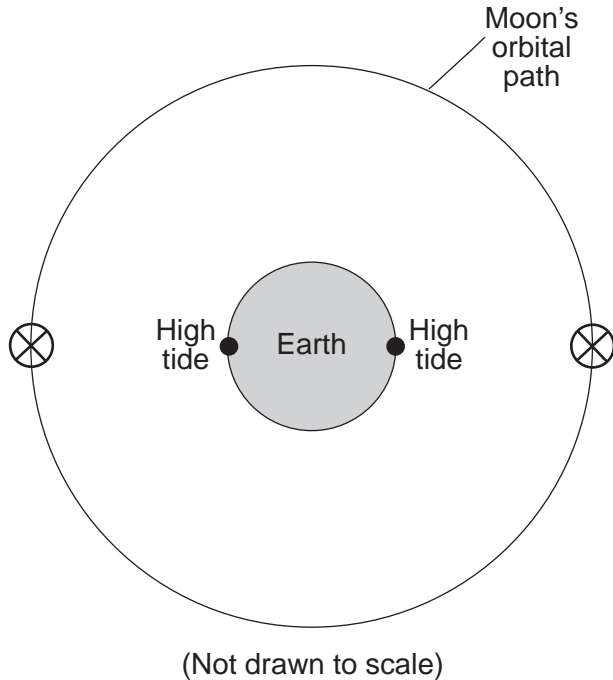

- 82 [1] Allow 1 credit if *both* texture and color are correct. Acceptable responses include, but are not limited to:

- texture: — fine grained  
 — nonvesicular or vesicular  
 — glassy  
 — noncrystalline  
 — grain size less than 1 mm
- color: — dark colored  
 — black  
 — green

- 83** [1] Allow 1 credit if *both* minerals are correct. Acceptable responses include, but are not limited to:
- plagioclase feldspar
  - potassium feldspar (orthoclase)
  - quartz
  - amphibole (hornblende)
  - biotite (mica)
- 84** [1] Allow 1 credit. Acceptable responses include, but are not limited to:
- WSW
  - SW
  - southwest
- 85** [1] Allow 1 credit for any value from 23.5 to 26.5 miles per million years.

## Regents Examination in Physical Setting/Earth Science

August 2008

### Chart for Converting Total Test Raw Scores to Final Examination Scores (Scaled Scores)

**The *Chart for Determining the Final Examination Score for the August 2008 Regents Examination in Physical Setting/Earth Science* will be posted on the Department's web site <http://www.emsc.nysed.gov/osa/> on Wednesday, August 13, 2008. Conversion charts provided for previous administrations of the Regents Examination in Physical Setting/Earth Science must NOT be used to determine students' final scores for this administration.**

### Submitting Teacher Evaluations of the Test to the Department

Suggestions and feedback from teachers provide an important contribution to the test development process. The Department provides an online evaluation form for State assessments. It contains spaces for teachers to respond to several specific questions and to make suggestions. Instructions for completing the evaluation form are as follows:

1. Go to [www.emsc.nysed.gov/osa/exameval](http://www.emsc.nysed.gov/osa/exameval).
2. Select the test title.
3. Complete the required demographic fields.
4. Complete each evaluation question and provide comments in the space provided.
5. Click the SUBMIT button at the bottom of the page to submit the completed form.

## Map to Core Curriculum

<b>August 2008 Physical Setting/Earth Science</b>			
<b>Question Numbers</b>			
Key Ideas/Performance Indicators	Part A	Part B	Part C
<b>Standard 1</b>			
Math Key Idea 1	10, 22	49, 51, 52, 55, 59	75, 78, 85
Math Key Idea 2	11, 15, 18, 25	58, 63	79, 84
Math Key Idea 3		62	
Science Inquiry Key Idea 1	8, 20, 28, 29, 31	42, 46, 47, 53, 54, 56, 57, 60	77
Science Inquiry Key Idea 2			
Science Inquiry Key Idea 3			73
Engineering Design Key Idea 1			
<b>Standard 2</b>			
Key Idea 1			
Key Idea 2			
Key Idea 3		65	
<b>Standard 6</b>			
Key Idea 1	8, 25, 32	39, 43	67, 69, 71, 81
Key Idea 2	9, 10, 11, 12, 13, 14, 16, 17, 19, 21, 22, 23, 27, 30, 32, 33, 34, 35	36, 37, 38, 40, 41, 44, 45, 59, 61, 62, 63, 64, 65	70, 72, 73, 74, 75, 76, 81, 82, 83
Key Idea 3	10, 22	46	80
Key Idea 4	20		
Key Idea 5	13, 14, 16, 17, 19, 23, 24, 27	45, 48, 49, 50, 53	66, 67, 71, 72, 73, 74, 75, 78, 84
Key Idea 6			
<b>Standard 7</b>			
Key Idea 1			
Key Idea 2			68
<b>Standard 4</b>			
Key Idea 1	1, 2, 3, 4, 5, 7, 10, 17, 20, 21, 23, 26, 27, 34	36, 37, 38, 41, 44, 45, 46, 51, 52, 53, 54, 55, 56, 57, 63	72, 73, 74, 75, 76, 77, 78, 79, 80, 81
Key Idea 2	6, 8, 9, 11, 12, 13, 14, 15, 16, 18, 19, 22, 24, 25, 28, 29, 31, 32, 33	39, 40, 47, 48, 49, 50, 58, 59, 60, 61, 62, 64, 65	66, 67, 68, 69, 70, 71, 84, 85
Key Idea 3	30, 35	42, 43	82, 83
<b>Reference Tables</b>			
ESRT 2001 Edition (Revised)	1, 3, 10, 11, 12, 18, 19, 20, 22, 24, 26	36, 37, 38, 40, 41, 42, 43, 47, 51, 52, 55, 58, 59, 60, 64	66, 70, 80, 82, 83, 85



## Regents Examination in Physical Setting/Earth Science – August 2008

### Chart for Converting Total Test Raw Scores to Final Examination Scores (Scale Scores)

To determine the student's final score, locate the student's Total Performance Test Score across the top of the chart and the Total Written Test Score down the side of the chart. The point where the two scores intersect is the student's final examination score. For example, a student receiving a Total Performance Test Score of 10 and Total Written Test Score of 72 would receive a final examination score of 90.

		<b>Total Performance Test Score</b>																
		<b>16</b>	<b>15</b>	<b>14</b>	<b>13</b>	<b>12</b>	<b>11</b>	<b>10</b>	<b>9</b>	<b>8</b>	<b>7</b>	<b>6</b>	<b>5</b>	<b>4</b>	<b>3</b>	<b>2</b>	<b>1</b>	<b>0</b>
<b>Total Written Test Score</b>	<b>85</b>	100	99	99	99	98	98	97	96	96	95	94	93	91	90	88	87	85
	<b>84</b>	99	99	98	98	98	97	96	96	95	94	93	92	91	89	88	86	84
	<b>83</b>	99	99	98	98	98	97	96	96	95	94	93	92	91	89	88	86	84
	<b>82</b>	98	98	98	97	97	96	95	95	94	93	92	91	90	88	87	85	83
	<b>81</b>	98	98	98	97	97	96	95	95	94	93	92	91	90	88	87	85	83
	<b>80</b>	97	97	97	96	96	95	95	94	93	92	91	90	89	88	86	84	82
	<b>79</b>	97	96	96	95	95	94	94	93	92	91	90	89	88	87	85	83	82
	<b>78</b>	97	96	96	95	95	94	94	93	92	91	90	89	88	87	85	83	82
	<b>77</b>	96	95	95	95	94	94	93	92	91	91	89	88	87	86	84	83	81
	<b>76</b>	95	95	94	94	93	93	92	91	91	90	89	88	86	85	83	82	80
	<b>75</b>	95	95	94	94	93	93	92	91	91	90	89	88	86	85	83	82	80
	<b>74</b>	94	94	93	93	92	92	91	90	90	89	88	87	86	84	83	81	79
	<b>73</b>	93	93	92	92	92	91	90	90	89	88	87	86	85	83	82	80	78
	<b>72</b>	92	92	92	91	91	90	90	89	88	87	86	85	84	82	81	79	77
	<b>71</b>	92	91	91	90	90	89	89	88	87	86	85	84	83	82	80	78	77
	<b>70</b>	92	91	91	90	90	89	89	88	87	86	85	84	83	82	80	78	77
	<b>69</b>	91	90	90	89	89	88	88	87	86	85	84	83	82	81	79	77	76
	<b>68</b>	90	90	89	89	88	88	87	86	85	85	84	82	81	80	78	77	75
	<b>67</b>	89	89	88	88	87	87	86	85	85	84	83	82	80	79	77	76	74
	<b>66</b>	88	88	87	87	86	86	85	85	84	83	82	81	80	78	77	75	73
<b>65</b>	87	87	87	86	86	85	84	84	83	82	81	80	79	77	76	74	72	
<b>64</b>	86	86	86	85	85	84	84	83	82	81	80	79	78	77	75	73	71	
<b>63</b>	86	85	85	84	84	83	83	82	81	80	79	78	77	76	74	72	71	
<b>62</b>	85	84	84	84	83	82	82	81	80	79	78	77	76	75	73	72	70	
<b>61</b>	85	84	84	84	83	82	82	81	80	79	78	77	76	75	73	72	70	
<b>60</b>	83	83	82	82	81	81	80	79	79	78	77	76	74	73	71	70	68	
<b>59</b>	83	83	82	82	81	81	80	79	79	78	77	76	74	73	71	70	68	
<b>58</b>	81	81	81	80	80	79	78	78	77	76	75	74	73	71	70	68	66	
<b>57</b>	80	80	80	79	79	78	78	77	76	75	74	73	72	71	69	67	65	
<b>56</b>	80	79	79	78	78	77	77	76	75	74	73	72	71	70	68	66	65	
<b>55</b>	79	78	78	78	77	77	76	75	74	74	72	71	70	69	67	66	64	
<b>54</b>	78	78	77	77	76	76	75	74	74	73	72	71	69	68	66	65	63	
<b>53</b>	77	77	76	76	75	75	74	73	73	72	71	70	69	67	66	64	62	
<b>52</b>	76	76	75	75	75	74	73	73	72	71	70	69	68	66	65	63	61	
<b>51</b>	75	75	75	74	74	73	73	72	71	70	69	68	67	65	64	62	60	
<b>50</b>	75	74	74	73	73	72	72	71	70	69	68	67	66	65	63	61	60	
<b>49</b>	74	73	73	72	72	71	71	70	69	68	67	66	65	64	62	60	59	
<b>48</b>	73	73	72	72	71	71	70	69	68	68	67	66	65	64	63	61	58	
<b>47</b>	72	72	71	71	70	70	69	68	68	67	66	65	63	62	60	59	57	
<b>46</b>	70	70	70	69	69	68	67	67	66	65	64	63	62	60	59	57	55	
<b>45</b>	69	69	69	68	68	67	67	66	65	64	63	62	61	60	58	56	54	
<b>44</b>	69	68	68	67	67	66	66	65	64	63	62	61	60	59	57	55	54	



**Total Performance Test Score**  
**August 2008 Examination in Physical Setting/Earth Science – continued**

**Total Performance Test Score**

	<b>16</b>	<b>15</b>	<b>14</b>	<b>13</b>	<b>12</b>	<b>11</b>	<b>10</b>	<b>9</b>	<b>8</b>	<b>7</b>	<b>6</b>	<b>5</b>	<b>4</b>	<b>3</b>	<b>2</b>	<b>1</b>	<b>0</b>
<b>43</b>	68	67	67	67	66	65	65	64	63	62	61	60	59	58	56	55	53
<b>42</b>	67	67	66	66	65	65	64	63	63	62	61	60	58	57	55	54	52
<b>41</b>	65	65	64	64	64	63	62	62	61	60	59	58	57	55	54	52	50
<b>40</b>	64	64	64	63	63	62	61	61	60	59	58	57	56	54	53	51	49
<b>39</b>	63	63	63	62	62	61	61	60	59	58	57	56	55	54	52	50	48
<b>38</b>	63	62	62	61	61	60	60	59	58	57	56	55	54	53	51	49	48
<b>37</b>	61	61	60	60	59	59	58	57	57	56	55	54	52	51	49	48	46
<b>36</b>	60	60	59	59	58	58	57	56	56	55	54	53	52	50	49	47	45
<b>35</b>	59	59	58	58	58	57	56	56	55	54	53	52	51	49	48	46	44
<b>34</b>	58	57	57	56	56	55	55	54	53	52	51	50	49	48	46	44	43
<b>33</b>	57	56	56	55	55	54	54	53	52	51	50	49	48	47	45	43	42
<b>32</b>	56	56	55	55	54	54	53	52	51	51	50	48	47	46	44	43	41
<b>31</b>	54	54	53	53	52	52	51	51	50	49	48	47	46	44	43	41	39
<b>30</b>	53	53	53	52	52	51	50	50	49	48	47	46	45	43	42	40	38
<b>29</b>	52	52	52	51	51	50	50	49	48	47	46	45	44	43	41	39	37
<b>28</b>	51	50	50	50	49	48	48	47	46	45	44	43	42	41	39	38	36
<b>27</b>	50	50	49	49	48	48	47	46	46	45	44	43	41	40	38	37	35
<b>26</b>	48	48	47	47	47	46	45	45	44	43	42	41	40	38	37	35	33
<b>25</b>	47	47	47	46	46	45	44	44	43	42	41	40	39	37	36	34	32
<b>24</b>	46	45	45	44	44	43	43	42	41	40	39	38	37	36	34	32	31
<b>23</b>	45	44	44	44	43	43	42	41	40	40	38	37	36	35	33	32	30
<b>22</b>	43	43	42	42	41	41	40	39	39	38	37	36	35	33	32	30	28
<b>21</b>	42	42	41	41	41	40	39	39	38	37	36	35	34	32	31	29	27
<b>20</b>	41	40	40	39	39	38	38	37	36	35	34	33	32	31	29	27	26
<b>19</b>	40	39	39	38	38	37	37	36	35	34	33	32	31	30	28	26	25
<b>18</b>	38	38	37	37	36	36	35	34	34	33	32	31	29	28	26	25	23
<b>17</b>	37	37	36	36	35	35	34	34	33	32	31	30	29	27	26	24	22
<b>16</b>	35	35	35	34	34	33	33	32	31	30	29	28	27	26	24	22	20
<b>15</b>	35	34	34	33	33	32	32	31	30	29	28	27	26	25	23	21	20
<b>14</b>	33	33	32	32	31	31	30	29	29	28	27	26	24	23	21	20	18
<b>13</b>	32	32	31	31	30	30	29	28	28	27	26	25	23	22	20	19	17
<b>12</b>	30	30	30	29	29	28	27	27	26	25	24	23	22	20	19	17	15
<b>11</b>	29	29	29	28	28	27	27	26	25	24	23	22	21	20	18	16	14
<b>10</b>	28	27	27	27	26	26	25	24	23	23	21	20	19	18	16	15	13
<b>9</b>	27	27	26	26	25	25	24	23	23	22	21	20	18	17	15	14	12
<b>8</b>	25	25	24	24	24	23	22	22	21	20	19	18	17	15	14	12	10
<b>7</b>	24	24	24	23	23	22	22	21	20	19	18	17	16	14	13	11	9
<b>6</b>	23	22	22	21	21	20	20	19	18	17	16	15	14	13	11	9	8
<b>5</b>	22	22	21	21	20	20	19	18	17	17	16	14	13	12	10	9	7
<b>4</b>	20	20	19	19	18	18	17	17	16	15	14	13	12	10	9	7	5
<b>3</b>	19	19	19	18	18	17	16	16	15	14	13	12	11	9	8	6	4
<b>2</b>	18	17	17	16	16	15	15	14	13	12	11	10	9	8	6	4	3
<b>1</b>	16	16	15	15	14	14	13	12	12	11	10	9	7	6	4	3	1
<b>0</b>	15	15	14	14	13	13	12	11	11	10	9	8	6	5	3	2	0