

The University of the State of New York
REGENTS HIGH SCHOOL EXAMINATION

**PHYSICAL SETTING
EARTH SCIENCE**

Tuesday, June 22, 2010 — 9:15 a.m. to 12:15 p.m., only

This is a test of your knowledge of Earth science. Use that knowledge to answer all questions in this examination. Some questions may require the use of the *2010 Edition Reference Tables for Physical Setting/Earth Science*. The reference tables are supplied separately. Be certain you have a copy of the *2010 Edition* of these reference tables before you begin the examination.

The answers to *all* questions are to be written in your separate answer booklet. Be sure to fill in the heading on the front of your answer booklet.

You are to answer all questions in all parts of this examination according to the directions provided in the examination booklet. All work should be written in pen, except for graphs and drawings, which should be done in pencil. You may use scrap paper to work out the answers to the questions, but be sure to record all your answers in your answer booklet.

When you have completed the examination, you must sign the statement printed on the first page of your answer booklet, indicating that you had no unlawful knowledge of the questions or answers prior to the examination and that you have neither given nor received assistance in answering any of the questions during the examination. Your answer booklet cannot be accepted if you fail to sign this declaration.

Notice . . .

A four-function or scientific calculator and a copy of the *2010 Edition Reference Tables for Physical Setting/Earth Science* must be available for you to use while taking this examination.

The use of any communications device is strictly prohibited when taking this examination. If you use any communications device, no matter how briefly, your examination will be invalidated and no score will be calculated for you.

DO NOT OPEN THIS EXAMINATION BOOKLET UNTIL THE SIGNAL IS GIVEN.

Part A

Answer all questions in this part.

Directions (1–35): For *each* statement or question, write in your answer booklet the *number* of the word or expression that, of those given, best completes the statement or answers the question. Some questions may require the use of the *2010 Edition Reference Tables for Physical Setting/Earth Science*.

- 1 The diagram below shows a heavy mass moving back and forth in a straight-line direction. The apparent direction of movement changes over time.

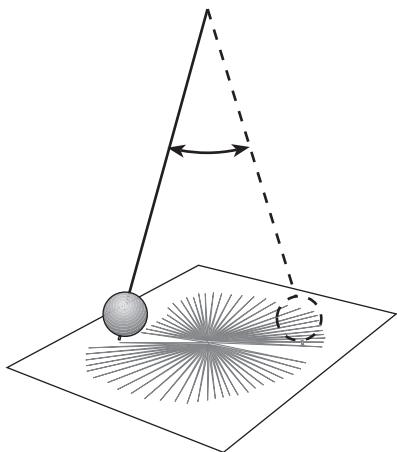

This device provides evidence that

- (1) Earth rotates
 - (2) Earth's axis is tilted
 - (3) Earth revolves
 - (4) Earth has a magnetic pole
- 2 Compared to the terrestrial planets, the Jovian planets have
- (1) smaller diameters
 - (2) greater average densities
 - (3) slower rates of rotation
 - (4) longer periods of revolution
- 3 Which two factors cause the perpendicular rays of the Sun to move between 23.5° N and 23.5° S?
- (1) tilt of Earth's axis and Earth's revolution
 - (2) tilt of Earth's axis and Earth's rotation
 - (3) eccentricity of Earth's orbit and Earth's revolution
 - (4) eccentricity of Earth's orbit and Earth's rotation

- 4 Which two stars are most similar in luminosity?

- (1) *Betelgeuse* and *Barnard's Star*
- (2) *Procyon B* and *Proxima Centauri*
- (3) *Polaris* and the Sun
- (4) *Alpha Centauri* and *Sirius*

- 5 The map below shows the location of Chicxulub Crater created 65.5 million years ago by an asteroid impact.



This impact event occurred at the same time as the

- (1) extinction of the dinosaurs
 - (2) initial opening of the Atlantic Ocean
 - (3) formation of the Catskill Delta
 - (4) evolution of the first mammals
- 6 Where has the process of nuclear fusion been occurring for over four billion years?
- (1) in Earth's inner core
 - (2) on the surface of the Moon
 - (3) at lithospheric plate boundaries
 - (4) in the Sun's interior
- 7 From Utica, New York, *Polaris* is observed at an altitude of approximately
- | | |
|----------------|----------------|
| (1) 43° | (3) 75° |
| (2) 47° | (4) 90° |

8 What is the dewpoint if the relative humidity is 100% and the air temperature is 20°C?

- (1) 0°C (3) 20°C
 (2) 10°C (4) 100°C

9 Which graph best represents the change in air pressure as air temperature increases at Earth's surface?

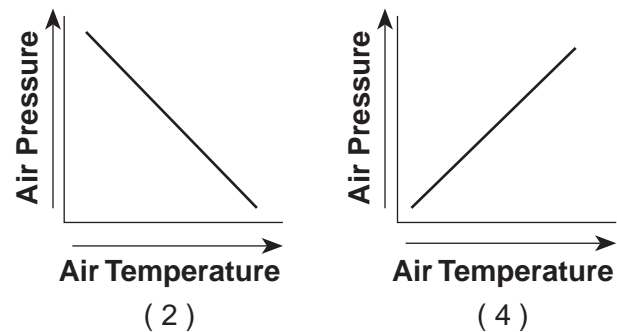
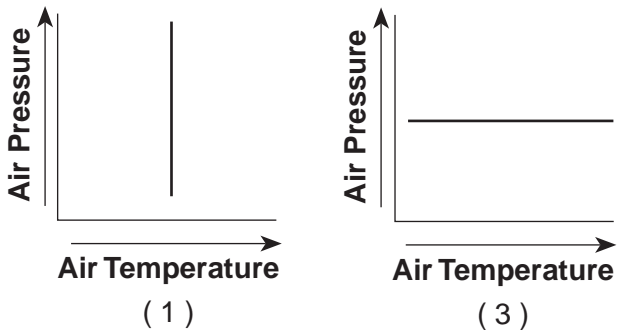

10 Compared to an area of Earth's surface with gentle slopes, an area with steeper slopes most likely has

- (1) less infiltration and more runoff
 (2) less infiltration and less runoff
 (3) more infiltration and more runoff
 (4) more infiltration and less runoff

11 Which geographic region is the most common source region for the mT air masses that move into New York State?

- (1) northern Canada
 (2) Gulf of Mexico
 (3) Arctic Ocean
 (4) southwestern United States

12 Which weather variable would most likely decrease ahead of an approaching storm system?

- (1) wind speed (3) cloud cover
 (2) air pressure (4) relative humidity

13 Which gas in Earth's upper atmosphere is beneficial to humans because it absorbs large amounts of ultraviolet radiation?

- (1) water vapor (3) nitrogen
 (2) methane (4) ozone

14 Which combination of climate factors generally results in the coldest temperatures?

- (1) low elevation and low latitude
 (2) low elevation and high latitude
 (3) high elevation and low latitude
 (4) high elevation and high latitude

15 The cross sections below show the surface bedrock in two different locations 20 miles apart. Rock layers are labeled 1, 2, 3, 4, and X. The rock layers have not been overturned.

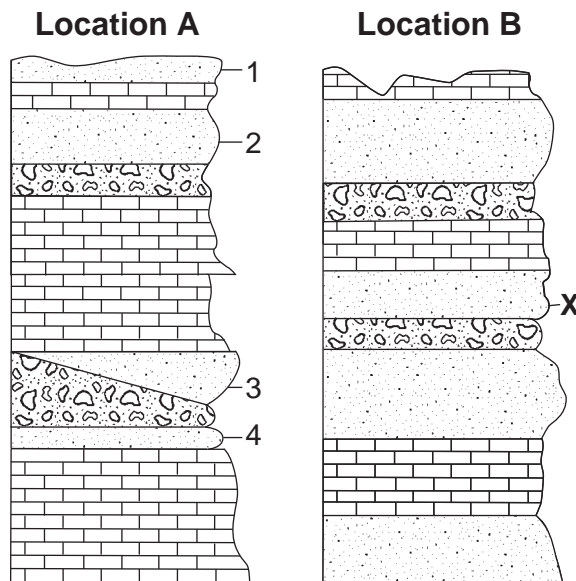

Rock layer X at location B is most likely the same relative age as which rock layer at location A?

- (1) 1 (3) 3
 (2) 2 (4) 4

16 In New York State, the risk of sunburn is greatest between 11 a.m. and 3 p.m. on summer days because

- (1) the air temperature is hot
 (2) the angle of insolation is high
 (3) Earth's surface reflects most of the sunlight
 (4) the Sun is closest to Earth

17 Deforestation increases the greenhouse effect on Earth because deforestation causes the atmosphere to contain

- (1) more carbon dioxide, which absorbs infrared radiation
- (2) less carbon dioxide, which absorbs short-wave radiation
- (3) more oxygen, which absorbs infrared radiation
- (4) less oxygen, which absorbs short-wave radiation

18 The interior of Earth between a depth of 5200 kilometers and 6300 kilometers is inferred to be composed mostly of

- (1) silicon and iron
- (2) silicon and oxygen
- (3) iron and lead
- (4) iron and nickel

19 Which two processes lead directly to the formation of both breccia and conglomerate?

- (1) melting and solidification
- (2) heat and pressure
- (3) compaction and cementation
- (4) evaporation and precipitation

20 Which igneous rock is dark colored, cooled rapidly on Earth's surface, and is composed mainly of plagioclase feldspar, olivine, and pyroxene?

- (1) obsidian
- (2) rhyolite
- (3) gabbro
- (4) scoria

21 Silicate minerals contain the elements silicon and oxygen. Which list contains only silicate minerals?

- (1) graphite, talc, and selenite gypsum
- (2) potassium feldspar, quartz, and amphibole
- (3) calcite, dolomite, and pyroxene
- (4) biotite mica, fluorite, and garnet

22 The maps below labeled A, B, and C show three different stream drainage patterns.

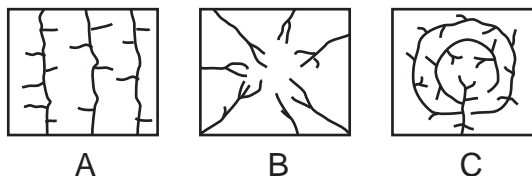

Which factor is primarily responsible for causing these three different drainage patterns?

- (1) amount of precipitation
- (2) bedrock structure
- (3) stream discharge
- (4) prevailing winds

23 Brachiopod fossils were found in a layer of limestone rock. In which type of environment did the limestone layer form?

- (1) shallow marine
- (2) tropical forest
- (3) coastal plain
- (4) interior grassland

24 The block diagram below represents a portion of the Grand Canyon.

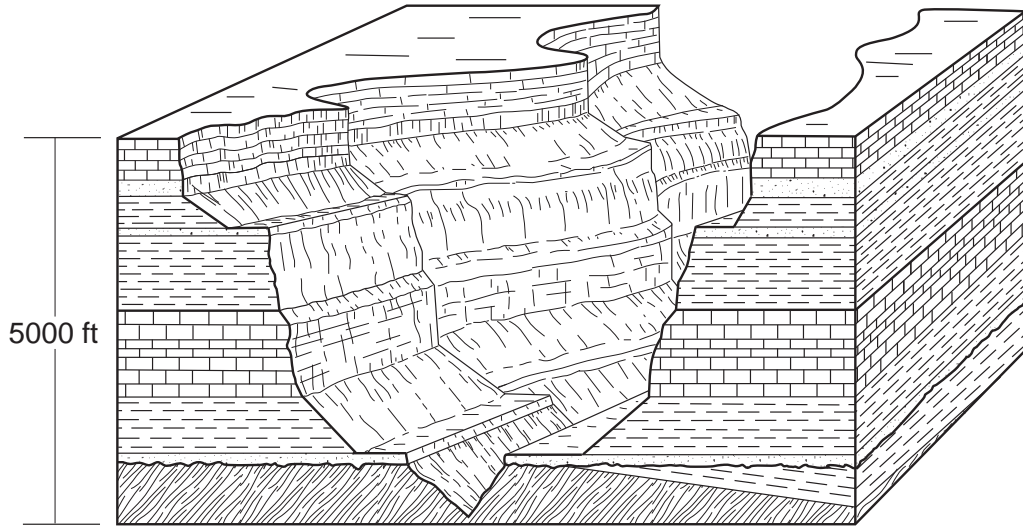

This region is best classified as a

- (1) plateau
- (2) mountain
- (3) plain
- (4) lowland

25 The map below shows four watershed regions in New York State labeled A through D.

Watersheds

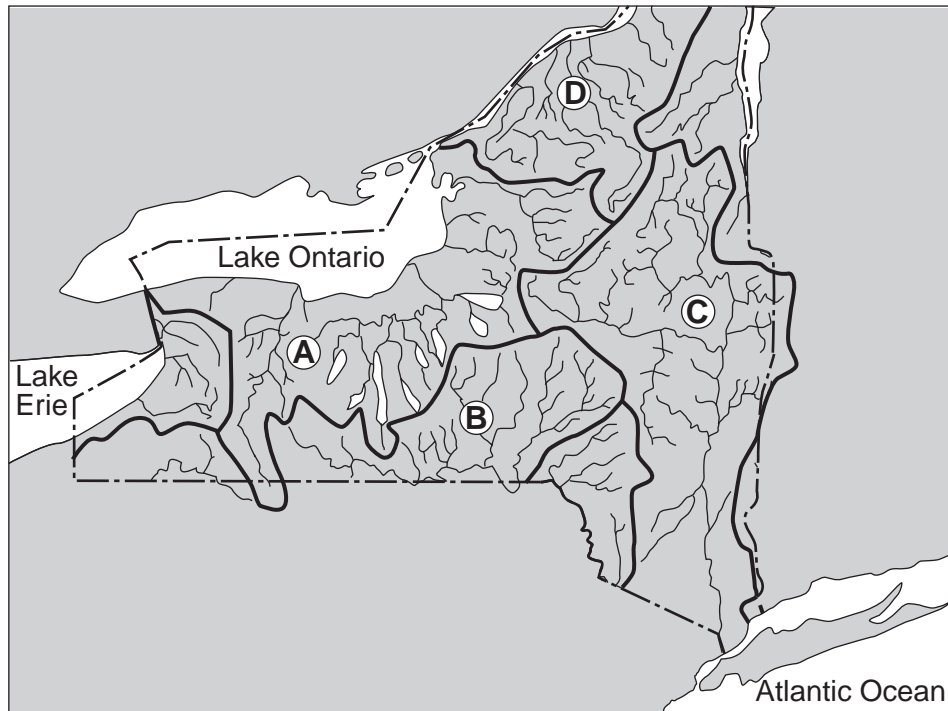

Which lettered section represents the watershed of the Mohawk and Hudson Rivers?

- (1) A
- (2) B
- (3) C
- (4) D

Base your answers to questions 26 and 27 on the diagram below, which shows specific events in the history of Earth from the beginning of the universe to the present.

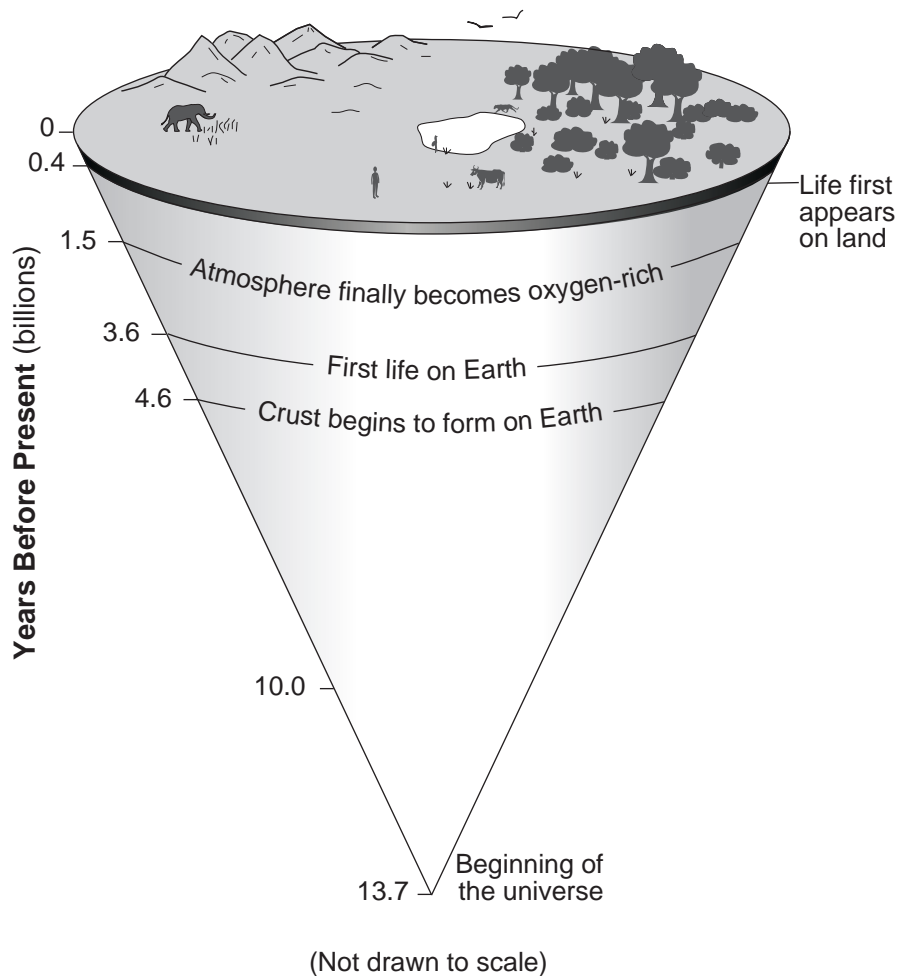

26 Approximately how many billion years after the beginning of the universe did a solid crust form on Earth?

- (1) 0.7 (3) 9.1
(2) 3.9 (4) 13.7

27 During which geologic era did life first appear on land?

- (1) Middle Archean (3) Middle Proterozoic
(2) Paleozoic (4) Cenozoic
-

28 Which cross section below best represents the conditions that cause early winter lake-effect snowstorms in New York State?

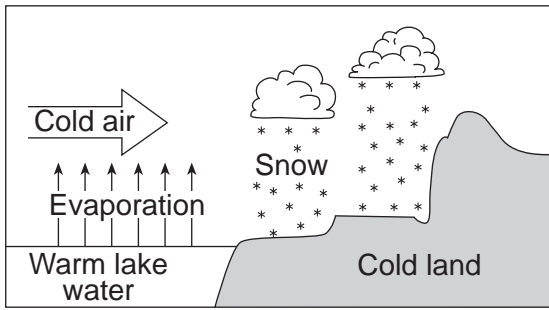

(1)

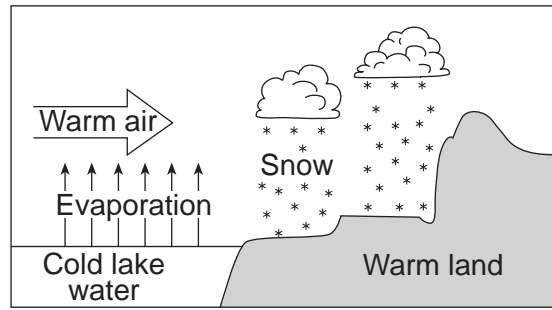

(3)

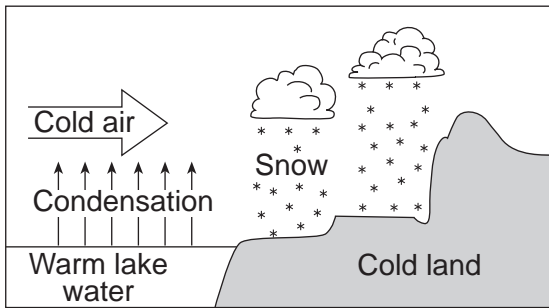

(2)

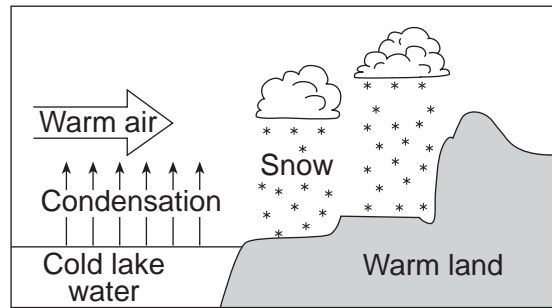

(4)

29 Which block diagram best represents the relative direction of plate motion at the San Andreas Fault?

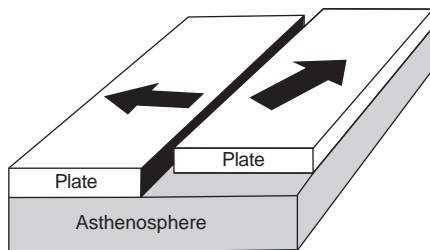

(1)

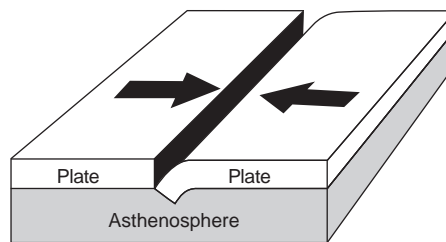

(3)

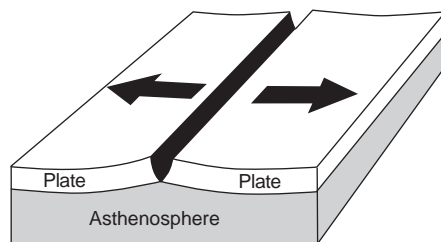

(2)

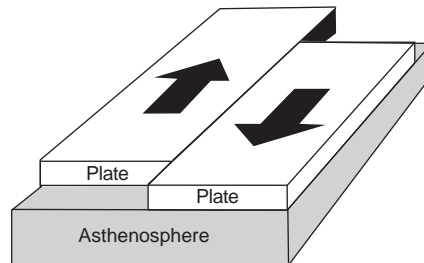

(4)

30 Which diagram best shows the grain size of some common sedimentary rocks?

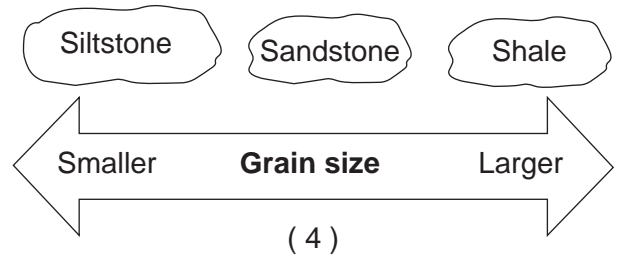
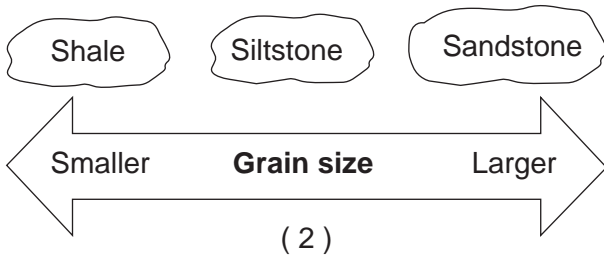
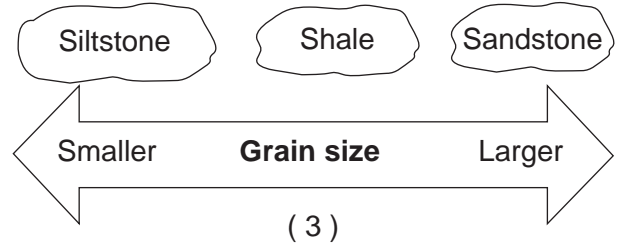
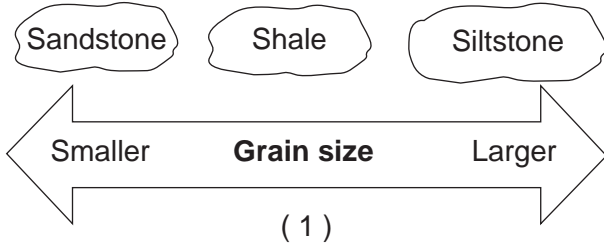

31 Which graph best represents the relative densities of three different types of igneous rock?

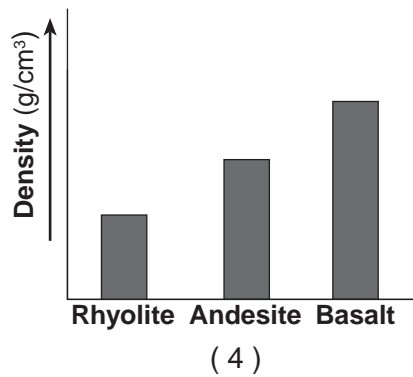
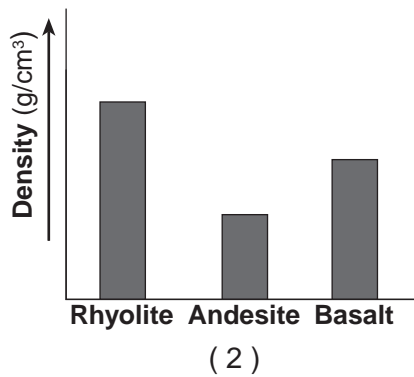
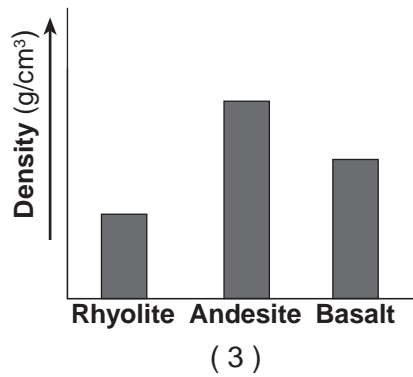
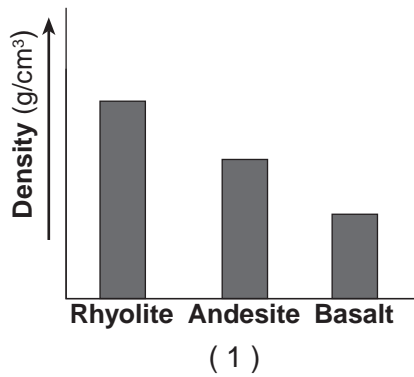

32 The diagram below shows the magnetic polarity preserved by minerals within the bedrock of the oceanic crust near the Mid-Atlantic Ridge. Letters A, B, C, and D represent locations in the ocean-floor bedrock.

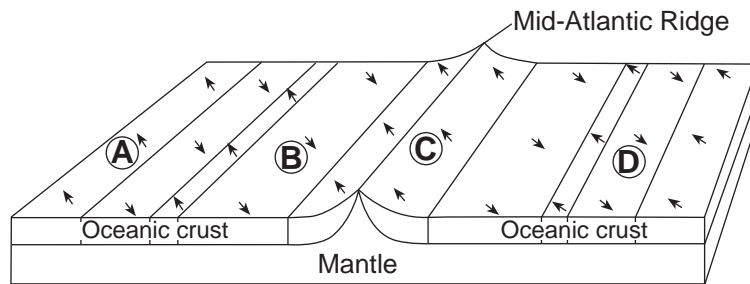

| Key | |
|----------------------------------|------------|
| Magnetic Polarity of the Bedrock | |
| ↖ Normal | ↘ Reversed |

The most recently formed bedrock is found at location

- (1) A
- (2) B
- (3) C
- (4) D

33 The diagram below shows a laboratory box used to demonstrate the process of convection in the atmosphere.

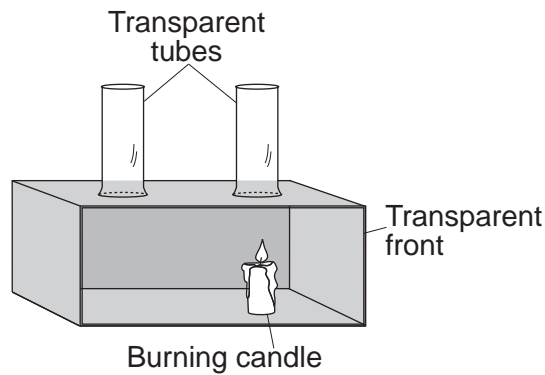

Which diagram has arrows that show the direction of airflow that occurs when the candle is burning?

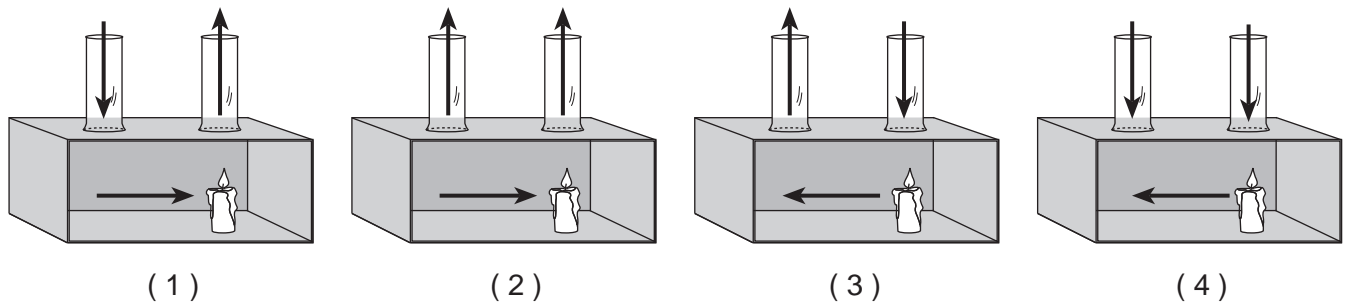

- 34 The diagram below shows the Moon at four positions in its orbit around Earth as viewed from above the North Pole. The date of one of the four positions has been labeled.

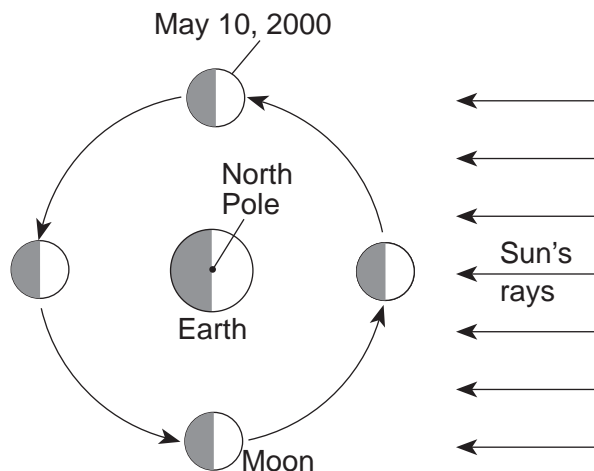

(Not drawn to scale)

Which photograph shows the appearance of the Moon as viewed by an observer in New York State on May 17, 2000?

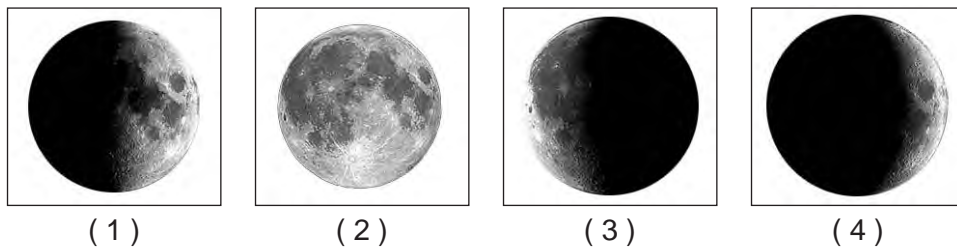

- 35 The diagram below represents a sample of rubidium-87 (^{87}Rb).

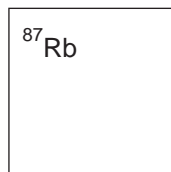

Which diagram represents the correct proportion of ^{87}Rb to its decay product, ^{87}Sr , after two half-lives?

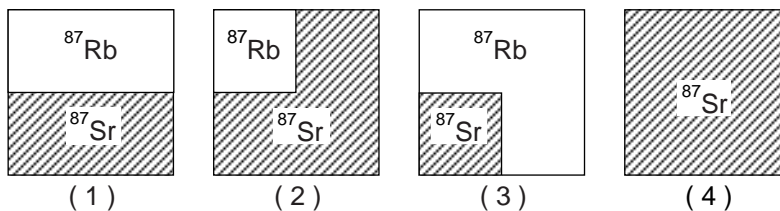

Part B-1

Answer all questions in this part.

Directions (36–50): For each statement or question, write in your answer booklet the number of the word or expression that, of those given, best completes the statement or answers the question. Some questions may require the use of the 2010 Edition Reference Tables for Physical Setting/Earth Science.

Base your answers to questions 36 through 38 on the block diagram below, which represents the landscape features associated with a meandering stream. WX is the location of a cross section. Location A indicates a landscape feature.

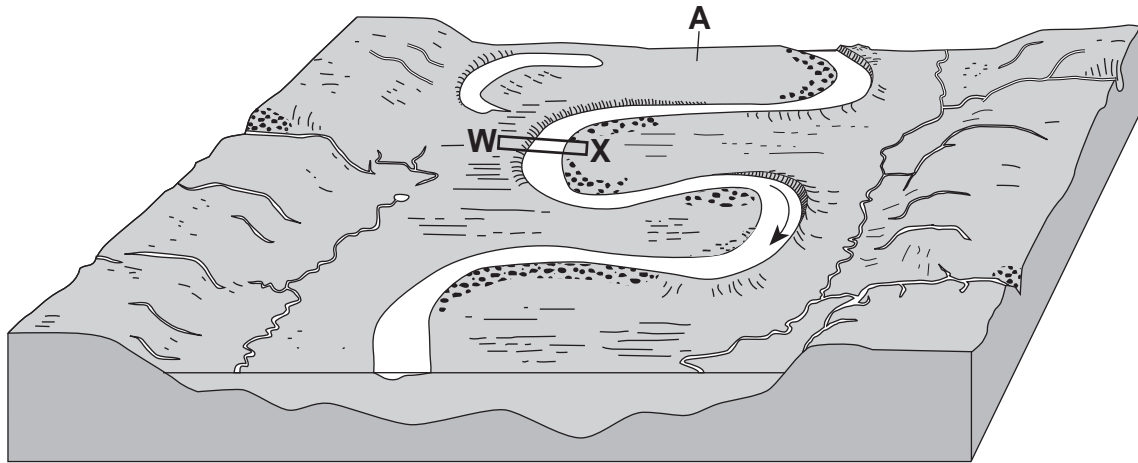

(Not drawn to scale)

- 36 The landscape feature at location A is best described as
- (1) a sandbar
 - (2) an escarpment
 - (3) a delta
 - (4) a floodplain

37 Which particle of quartz shows evidence of being transported the farthest distance by the stream?

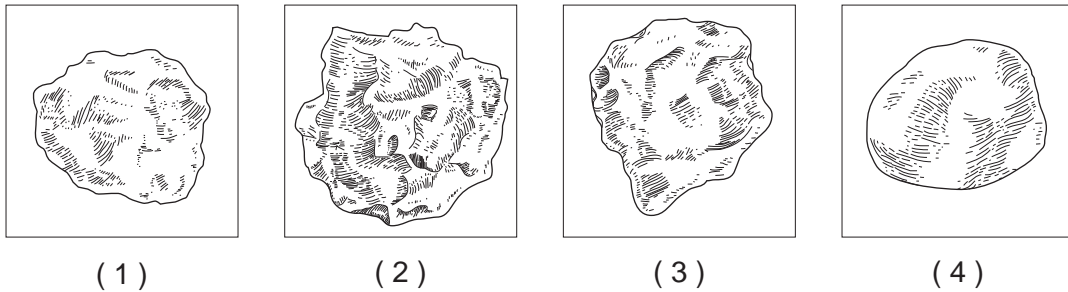

38 Which cross section best represents the shape of the stream bottom at WX?

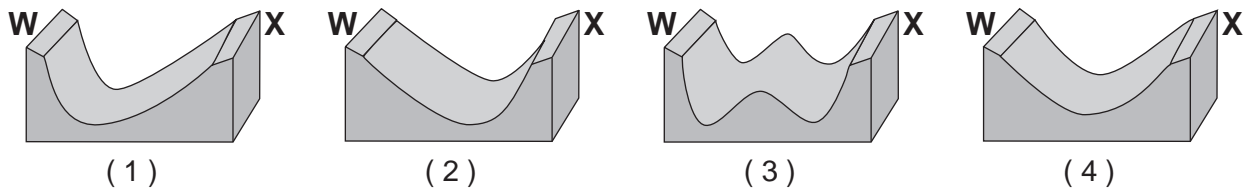

Base your answers to questions 39 through 42 on the geologic cross section below of a region of Earth's crust. Rock layers A through E have been labeled. Two index fossils are shown and their locations within the rock layers are indicated.

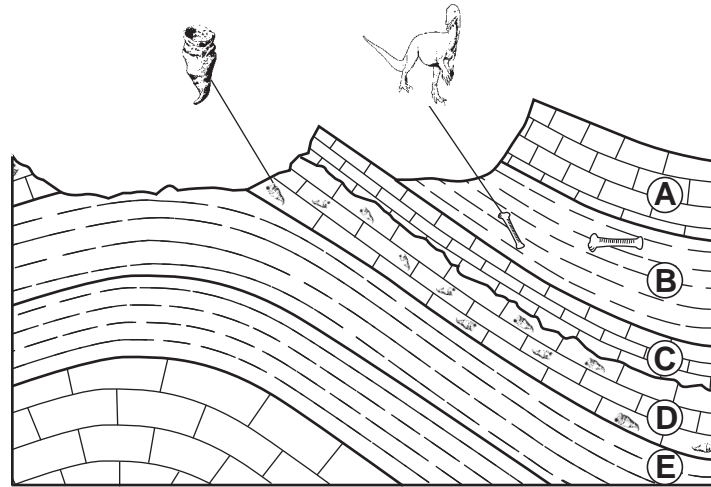

39 What caused the valleys and ridges in this area?

- (1) Some rock layers are folded more than others.
- (2) Rock layers were not deposited in the valley areas.
- (3) Some rock layers are more resistant to weathering and erosion than others.
- (4) Folding caused the ridge rocks to undergo regional metamorphism.

40 Which list of rock layers best matches the deposited sediments from which they were formed?

| |
|------------------------|
| A—calcite precipitates |
| B—clay |
| C—calcite precipitates |
| D—shell fragments |

(1)

| |
|-----------------|
| A—plant remains |
| B—mica |
| C—plant remains |
| D—clay |

(3)

| |
|-------------------|
| A—quartz sand |
| B—silt |
| C—quartz sand |
| D—shell fragments |

(2)

| |
|------------------------|
| A—calcite precipitates |
| B—halite precipitates |
| C—hematite |
| D—gypsum |

(4)

- 41 Approximately how many million years older than bedrock layer *B* is bedrock layer *D*?
- (1) 150 (3) 340
(2) 220 (4) 420
- 42 Evidence of tectonic activity in this cross section is provided by the
- (1) folding and tilting of the rock layers
(2) faulting and movement of the rock layers
(3) igneous intrusion into the rock layers
(4) collision of crustal plate boundaries in the rock layers
-

Base your answer to question 43 on the seismogram below. The seismogram was recorded at a seismic station and shows the arrival times of the first *P*-wave and *S*-wave from an earthquake.

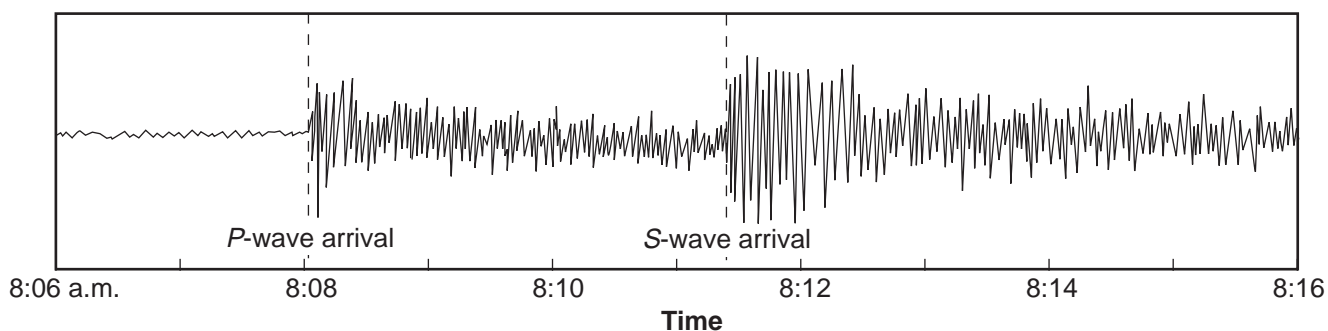

- 43 Which part of this seismogram is used to find the distance to the epicenter of the earthquake?
- (1) *P*-wave arrival time, only
(2) *S*-wave arrival time, only
(3) difference in the arrival time of the *P*-wave and *S*-wave
(4) difference in the height of the *P*-wave and *S*-wave
-

Base your answers to questions 44 through 47 on the maps and the passage below. The maps show differences in trade wind strength, ocean current direction, and water temperature associated with air-pressure changes from normal climate conditions to El Niño conditions.

Normal Climate Conditions

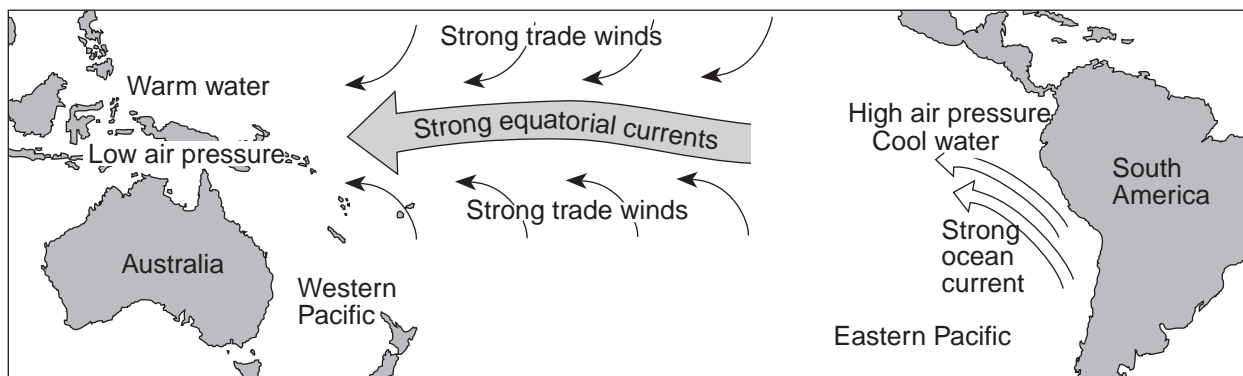

El Niño Conditions

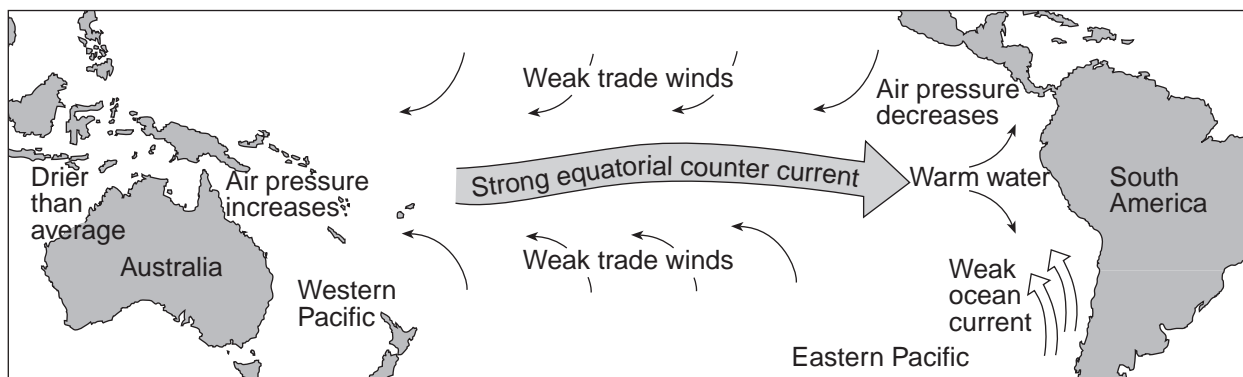

El Niño Conditions

El Niño conditions occur with a buildup of warm water in the equatorial Pacific Ocean off the coast of South America. The immediate cause of this buildup is a change in air pressure that weakens the southern trade winds. These are the planetary winds that move air from 30° S to the equator. Normally, these strong, steady winds, with the help of their counterparts in the Northern Hemisphere, push equatorial water westward away from South America. But, at intervals of two to seven years, these winds weaken, causing the westward water flow to reverse. This results in an accumulation of unusually warm water on the east side of the equatorial Pacific Ocean. This warm water not only changes the characteristics of the air above it, but also is thought to be the cause of weather changes around the world. El Niño conditions may last only a few months, but often last a year or two.

- 44 The trade winds between 30° S and the equator usually blow from the
- (1) northeast
 - (2) southeast
 - (3) northwest
 - (4) southwest
- 45 Under normal climate conditions, what are the characteristics of the surface ocean current that flows along most of the west coast of South America?
- (1) cool water moving toward the equator
 - (2) cool water moving away from the equator
 - (3) warm water moving toward the equator
 - (4) warm water moving away from the equator
- 46 During El Niño conditions, air above the Pacific Ocean moving over the land on the equatorial west coast of South America is likely to be
- (1) cooler and drier than usual
 - (2) cooler and wetter than usual
 - (3) warmer and drier than usual
 - (4) warmer and wetter than usual
- 47 Equatorial Pacific trade winds weaken during El Niño conditions when air pressure
- (1) falls in the western Pacific and rises in the eastern Pacific
 - (2) falls in both the western and eastern Pacific
 - (3) rises in the western Pacific and falls in the eastern Pacific
 - (4) rises in both the western and eastern Pacific
-

Base your answers to questions 48 through 50 on the diagram below, which shows four tubes containing 500 milliliters of sediment labeled A, B, C, and D. Each tube contains well-sorted, loosely packed particles of uniform shape and size and is open at the top. The classification of the sediment in each tube is labeled.

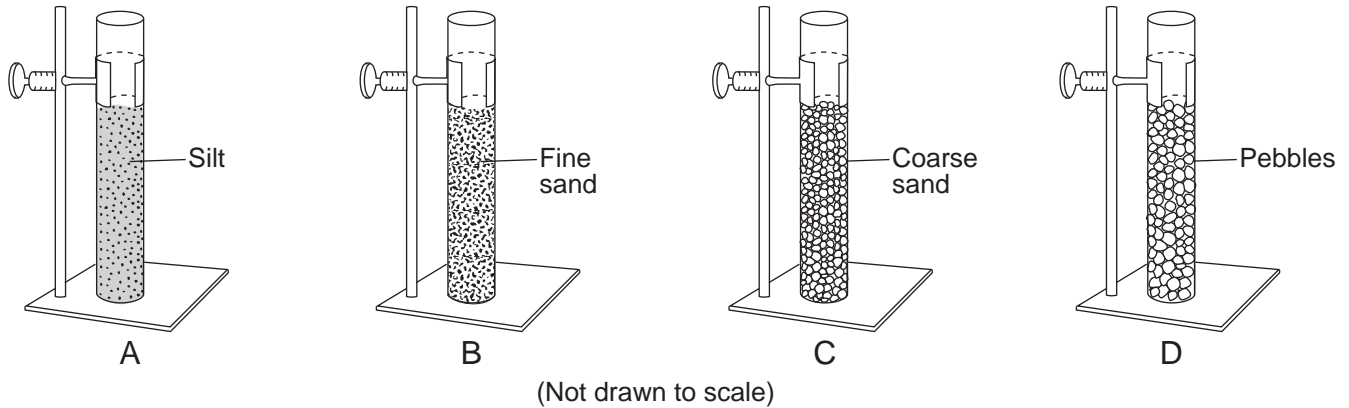

48 Water will be able to infiltrate each of these sediment samples if the sediment is

- (1) saturated and impermeable
- (2) saturated and permeable
- (3) unsaturated and impermeable
- (4) unsaturated and permeable

49 Water was poured into each tube of sediment and the time it took for the water to infiltrate to the bottom was recorded, in seconds. Which data table best represents the recorded results?

| Tubes | Infiltration Time (s) |
|-------|-----------------------|
| A | 5.2 |
| B | 3.4 |
| C | 2.8 |
| D | 2.3 |

(1)

| Tubes | Infiltration Time (s) |
|-------|-----------------------|
| A | 2.4 |
| B | 2.9 |
| C | 3.6 |
| D | 3.8 |

(3)

| Tubes | Infiltration Time (s) |
|-------|-----------------------|
| A | 3.2 |
| B | 3.3 |
| C | 3.2 |
| D | 3.3 |

(2)

| Tubes | Infiltration Time (s) |
|-------|-----------------------|
| A | 3.0 |
| B | 5.8 |
| C | 6.1 |
| D | 2.8 |

(4)

50 Each tube is filled with water to the top of the sediments and the tube is covered with a fine screen. The tubes are then tipped upside down so the water can drain. In which tube would the sediment retain the most water?

- (1) A
- (2) B
- (3) C
- (4) D

Part B–2

Answer all questions in this part.

Directions (51–65): Record your answers in the spaces provided in your answer booklet. Some questions may require the use of the *2010 Edition Reference Tables for Physical Setting/Earth Science*.

Base your answers to questions 51 through 53 on the data table below, which shows some galaxies, their distances from Earth, and the velocities at which they are moving away from Earth.

| Name of Galaxy | Distance (million light-years) | Velocity (thousand km/s) |
|-----------------------|---|-------------------------------------|
| Virgo | 70 | 1.2 |
| Ursa Major 1 | 900 | 15 |
| Leo | 1100 | 19 |
| Bootes | 2300 | 40 |
| Hydra | 3600 | 61 |

One light-year = distance light travels in one year

- 51 On the grid *in your answer booklet*, use an **X** to plot the distance and velocity for each galaxy from the data table to show the relationship between each galaxy's distance from Earth and the velocity at which it is moving away from Earth. Connect the **Xs** with a smooth line. [1]
- 52 State the general relationship between a galaxy's distance from Earth and the velocity at which the galaxy is moving away from Earth. [1]
- 53 Another galaxy is traveling away from Earth at a velocity of 70 thousand kilometers per second. Estimate that galaxy's distance from Earth in million light-years. [1]
-

Base your answers to questions 54 through 57 on map A and map B below, and on map C in your answer booklet, which show evidence that much of New York State was once covered by a glacial ice sheet. Map A shows the location of the Finger Lakes Region in New York State. The boxed areas on map A were enlarged to create maps B and C. Map B shows a portion of a drumlin field near Oswego, New York. Map C, in your answer booklet, shows the locations of glacial moraines and outwash plains on Long Island, New York.

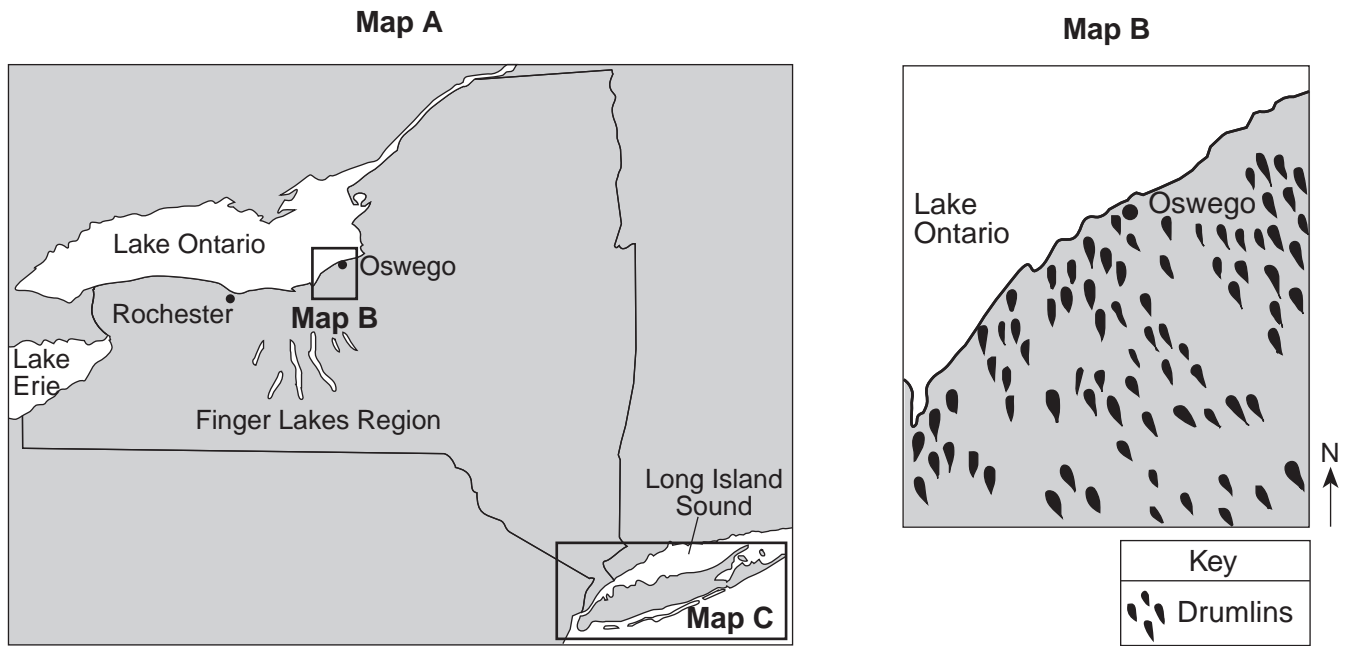

54 The arrangement of the drumlins on map B indicates that a large ice sheet advanced across New York State in which compass direction? [1]

55 The diagrams below represent three sediment samples labeled X, Y, and Z. These samples were collected from three locations marked with empty boxes (□) on map C in your answer booklet.

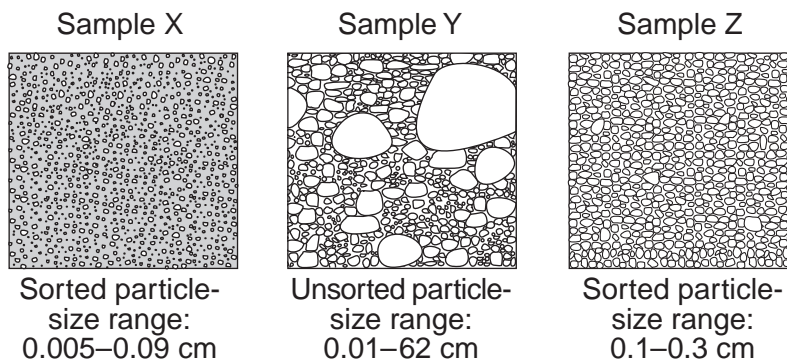

(Not drawn to scale)

In your answer booklet, write the letter of each sample in the correct box on map C to indicate the location from which each sample was most likely collected. [1]

- 56 The drawing below shows a glacial erratic found on the beach of the north shore of Long Island near the Harbor Hill moraine. This boulder is composed of one-billion-year-old gneiss.

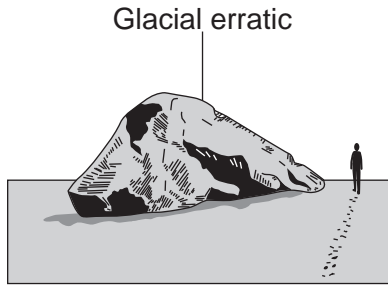

Which New York State landscape region has surface bedrock similar in age to this erratic? [1]

- 57 Explain how the effect of global warming on present-day continental glaciers could affect New York City and Long Island. [1]

Base your answers to questions 58 through 60 on the geologic cross section below. The rock layers have not been overturned.

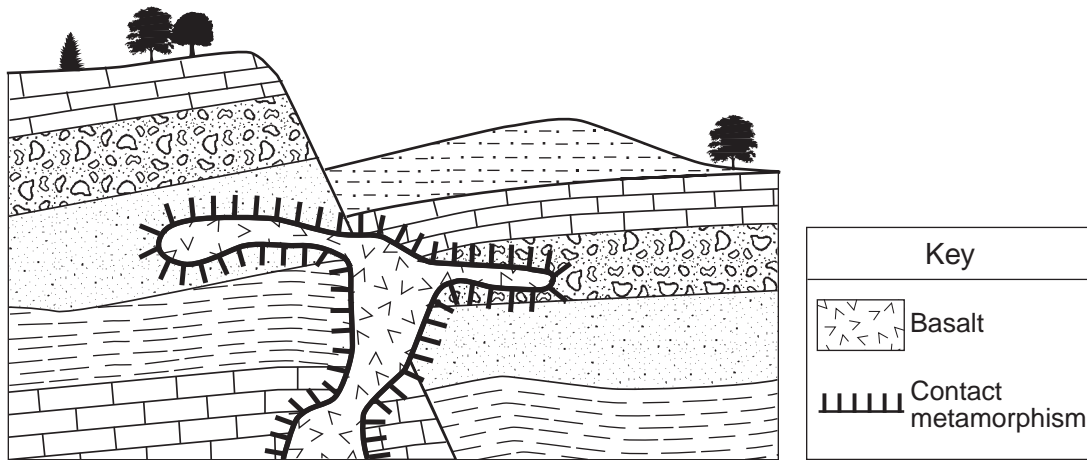

(Not drawn to scale)

- 58 The index fossil *Dicellograptus* was found in the shale layer. During which geologic time period did this shale layer form? [1]
- 59 Describe *one* piece of evidence from the cross section that supports the inference that the fault is older than the basalt intrusion. [1]
- 60 Explain why carbon-14 could *not* be used to determine the age of the *Dicellograptus* fossil. [1]

Base your answers to questions 61 through 65 on the map and the modified Mercalli intensity scale below. The map shows modified Mercalli intensity scale damage zones resulting from a large earthquake that occurred in 1964. The earthquake's epicenter was near Anchorage, Alaska. The cities Kodiak and Anchorage are shown on the map. The Mercalli scale describes earthquake damage at Earth's surface.

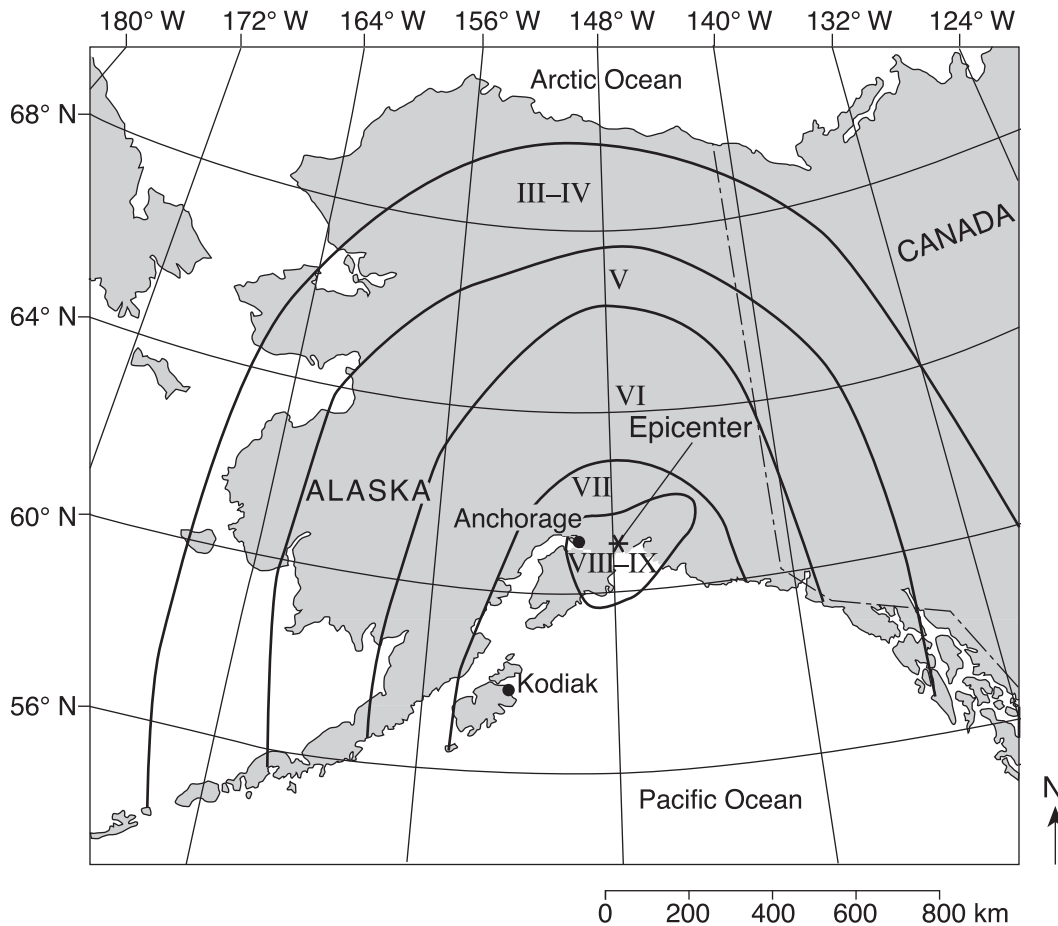

Modified Mercalli Intensity Scale

| | | | |
|-----|--|------|--|
| I | Instrumental: detected only by instruments | VII | Very strong: noticed by people in autos Damage to poor construction |
| II | Very feeble: noticed only by people at rest | VIII | Destructive: chimneys fall, much damage in substantial buildings, heavy furniture overturned |
| III | Slight: felt by people at rest Like passing of a truck | IX | Ruinous: great damage to substantial structures Ground cracked, pipes broken |
| IV | Moderate: generally perceptible by people in motion Loose objects disturbed | X | Disastrous: many buildings destroyed |
| V | Rather strong: dishes broken, bells rung, pendulum clocks stopped People awakened | XI | Very disastrous: few structures left standing |
| VI | Strong: felt by all, some people frightened Damage slight, some plaster cracked | XII | Catastrophic: total destruction |

- 61 Describe *one* type of damage that occurred in Anchorage but *not* in Kodiak. [1]
- 62 Write the names of the *two* converging tectonic plates that caused this earthquake. [1]
- 63 Explain why S-waves from this earthquake were *not* directly received on the opposite side of Earth. [1]
- 64 This earthquake produced a large ocean-floor displacement. Identify *one* dangerous geologic event affecting Pacific Ocean shorelines as a result of this ocean-floor displacement. [1]
- 65 Determine the latitude and longitude of this epicenter. Include the units and compass directions in your answer. [1]
-

Part C

Answer all questions in this part.

Directions (66–85): Record your answers in the spaces provided in your answer booklet. Some questions may require the use of the *2010 Edition Reference Tables for Physical Setting/Earth Science*.

Base your answers to questions 66 through 69 on the map in your answer booklet, which shows partially drawn contour lines. **X**s indicate elevations in meters. Letters *A*, *B*, *C*, and *D* represent locations on the map.

- 66 On the map *in your answer booklet*, complete the 250-meter contour line. [1]
- 67 On the portion of the map showing contour lines *in your answer booklet*, place an **X** in an area where an elevation of 55 meters is located. [1]
- 68 Calculate the stream gradient from elevation *A* to elevation *B*. Label your answer with the correct units. [1]
- 69 On the grid *in your answer booklet*, construct a topographic profile along line *CD*. Plot with an **X** the elevation of *each* contour line that crosses line *CD*. Connect the **X**s from *C* to *D* with a smooth, curved line to complete the profile. Elevations *C* and *D* have already been plotted. [1]
-

Base your answers to questions 70 through 73 on the diagrams below, which show the apparent path and solar noon positions of the Sun on specific dates at three different locations on Earth.

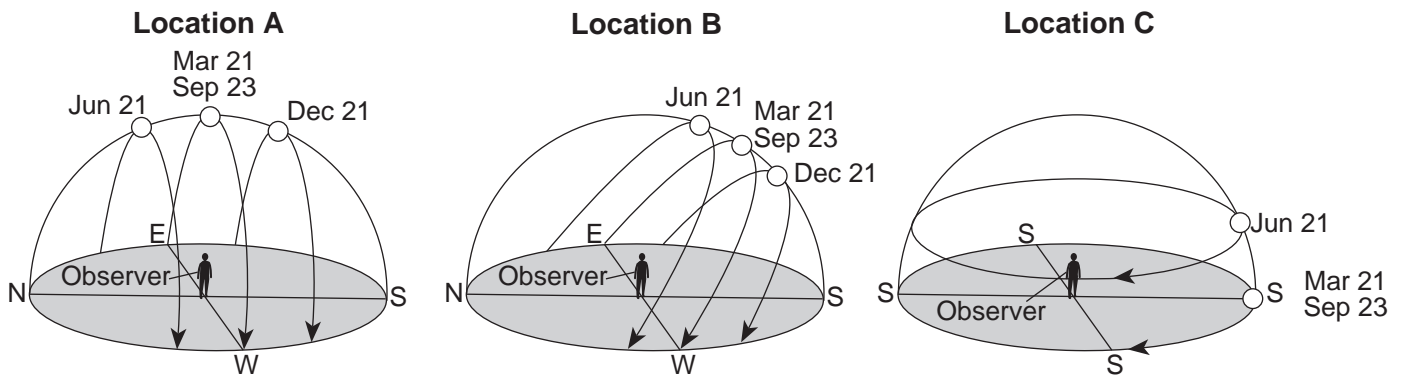

- 70 What evidence indicates that the observer at location *A* is at the equator? [1]
- 71 Explain why the observer's shadow at location *B* will always point northward at solar noon. [1]
- 72 On the diagram *in your answer booklet*, draw a line representing the apparent path of the Sun at location *B* on August 21. [1]
- 73 How many hours of daylight are seen by the observer at location *C* on June 21? [1]
-

Base your answers to questions 74 through 77 on the passage below.

The Moon Is Moving Away While Earth's Rotation Slows

Tides on Earth are primarily caused by the gravitational force of the Moon acting on Earth's surface. The Moon causes two tidal bulges to occur on Earth: the direct tidal bulge occurs on the side facing the Moon, and the indirect tidal bulge occurs on the opposite side of Earth. Since Earth rotates, the bulges are swept forward along Earth's surface. This advancing bulge helps pull the Moon forward in its orbit, resulting in a larger orbital radius. The Moon is actually getting farther away from Earth, at a rate of approximately 3.8 centimeters per year.

The Moon's gravity is also pulling on the direct tidal bulge. This pulling on the bulge causes friction of ocean water against the ocean floor, slowing the rotation of Earth at a rate of 0.002 second per 100 years.

- 74 The diagram *in your answer booklet* shows the Moon and Earth in line with each other in space. On the diagram, place an **X** on Earth's surface to indicate where the direct tidal bulge is occurring. [1]
- 75 Explain why the force of gravity between the Moon and Earth will *decrease* over time. [1]
- 76 In 100,000 years, the rotation of Earth will be slower by how many seconds? [1]
- 77 Explain why the Moon has a greater influence than the Sun on Earth's tides. [1]
-

Base your answers to questions 78 through 81 on the cross section below, which shows the bedrock structure of a portion of the lithosphere. Letters A through D represent locations in the lithosphere.

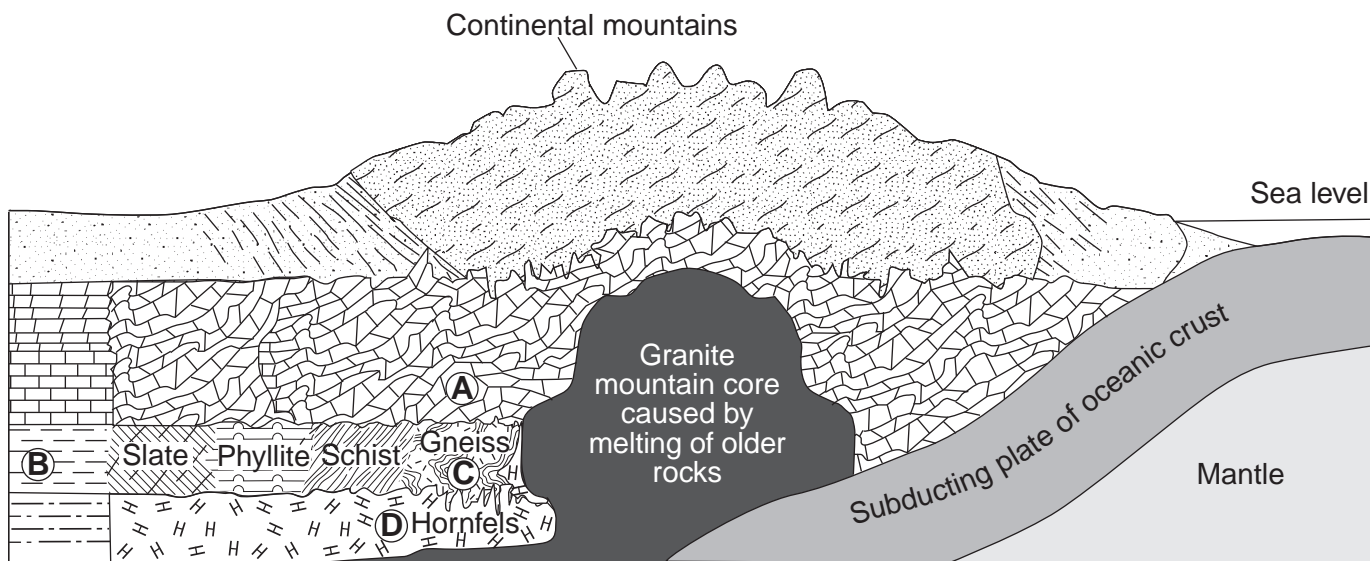

(Not drawn to scale)

- 78 Identify *one* of the most abundant minerals in the metamorphic rock at location A. [1]
- 79 Explain why the type of rock changes between locations B and C. [1]
- 80 Identify the grain size of the metamorphic rock at location D. [1]
- 81 Explain why the oceanic crust subducts beneath the continental crust when the two plates collide. [1]
-

Base your answers to questions 82 through 85 on the information and weather map below. The weather map shows the center of a low-pressure system. The symbol **— · · · —** represents the dry line which separates cT and mT air masses. Isobars are drawn at intervals of 4 millibars. Letter A indicates a weather station model.

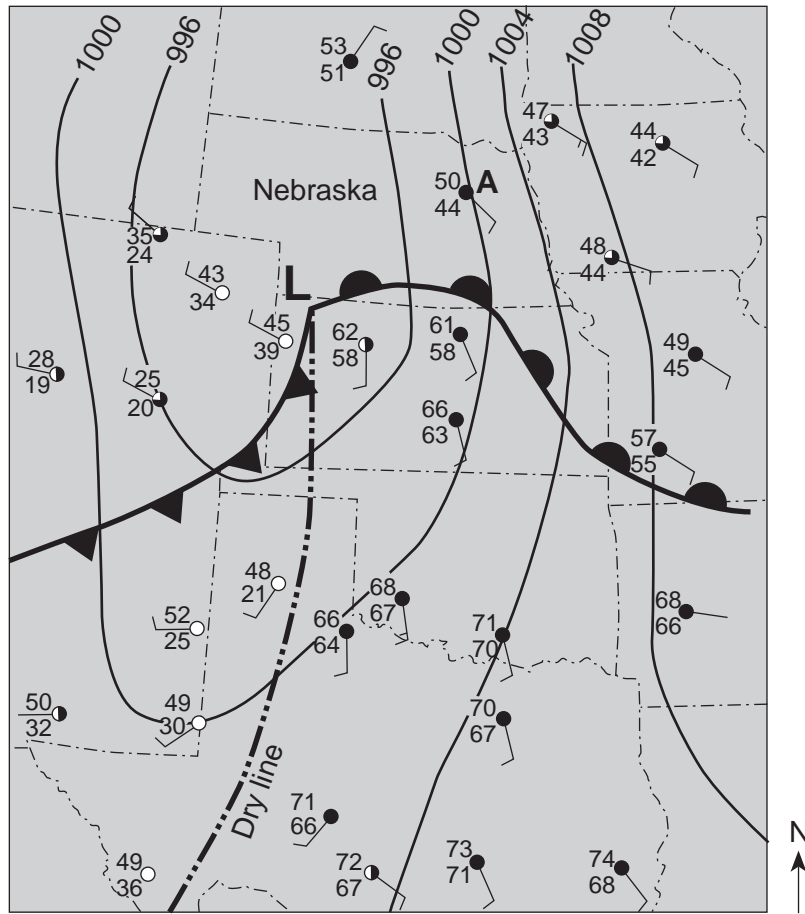

- 82 The atmospheric conditions in eastern Nebraska are represented on the map by a station model labeled A. *In your answer booklet*, fill in the correct information for each weather variable, based on station model A. [1]
- 83 Compared to the temperature and humidity of the air on the east side of the dry line, describe the temperature and humidity of the air on the west side. [1]
- 84 Explain why the warm air is rising along the warm front. [1]
- 85 In what compass direction will the center of this low-pressure system most likely move if it follows a normal storm track? [1]
-

**PHYSICAL SETTING
 EARTH SCIENCE**

Tuesday, June 22, 2010 — 9:15 a.m. to 12:15 p.m., only

ANSWER BOOKLET

Male

Student Sex: Female

Teacher

School Grade

Answer all questions in this examination. Record your answers in this booklet.

Part A

- | | | |
|----------|----------|----------|
| 1 | 13 | 25 |
| 2 | 14 | 26 |
| 3 | 15 | 27 |
| 4 | 16 | 28 |
| 5 | 17 | 29 |
| 6 | 18 | 30 |
| 7 | 19 | 31 |
| 8 | 20 | 32 |
| 9 | 21 | 33 |
| 10 | 22 | 34 |
| 11 | 23 | 35 |
| 12 | 24 | |

Part A Score

**Performance Test Score
 (Maximum Score: 16)**

| Part | Maximum Score | Student's Score |
|------|---------------|-----------------|
| A | 35 | |
| B-1 | 15 | |
| B-2 | 15 | |
| C | 20 | |

**Total Written Test Score
 (Maximum Raw Score: 85)**

**Final Score
 (from conversion chart)**

Raters' Initials:

Rater 1 **Rater 2**

Part B-1

- | | |
|----------|----------|
| 36 | 44 |
| 37 | 45 |
| 38 | 46 |
| 39 | 47 |
| 40 | 48 |
| 41 | 49 |
| 42 | 50 |
| 43 | |

Part B-1 Score

The declaration below must be signed when you have completed the examination.

I do hereby affirm, at the close of this examination, that I had no unlawful knowledge of the questions or answers prior to the examination and that I have neither given nor received assistance in answering any of the questions during the examination.

Signature

Part B-2

For Raters Only

51

Velocity Versus Distance

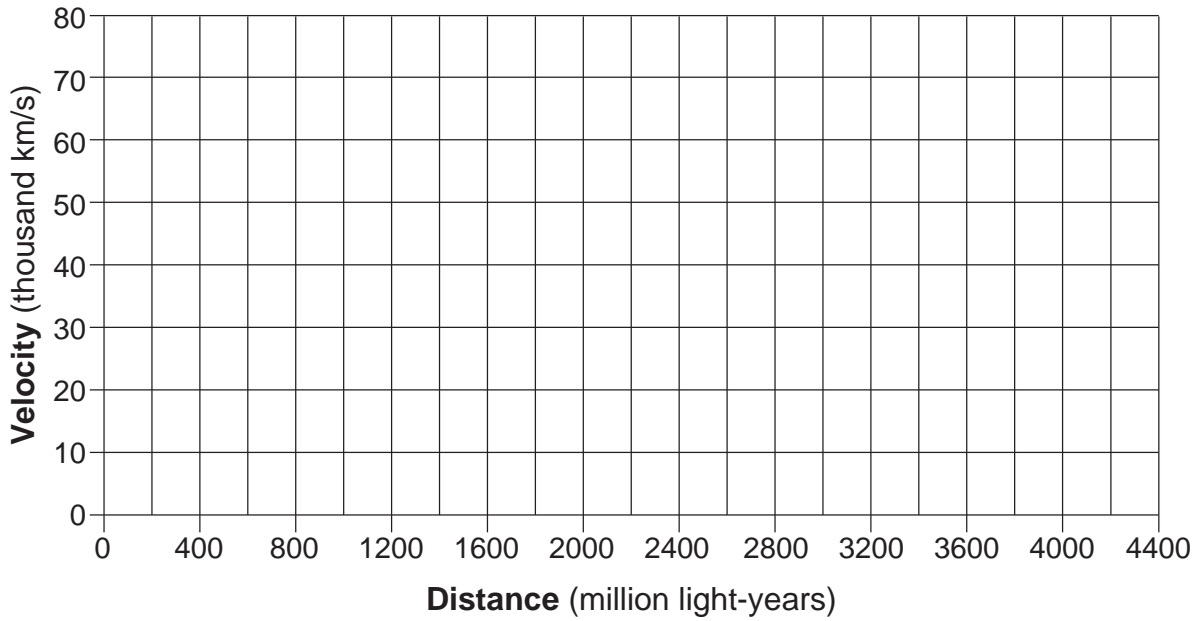

51

52

52

53

_____ million light-years

53

54

54

55

Map C

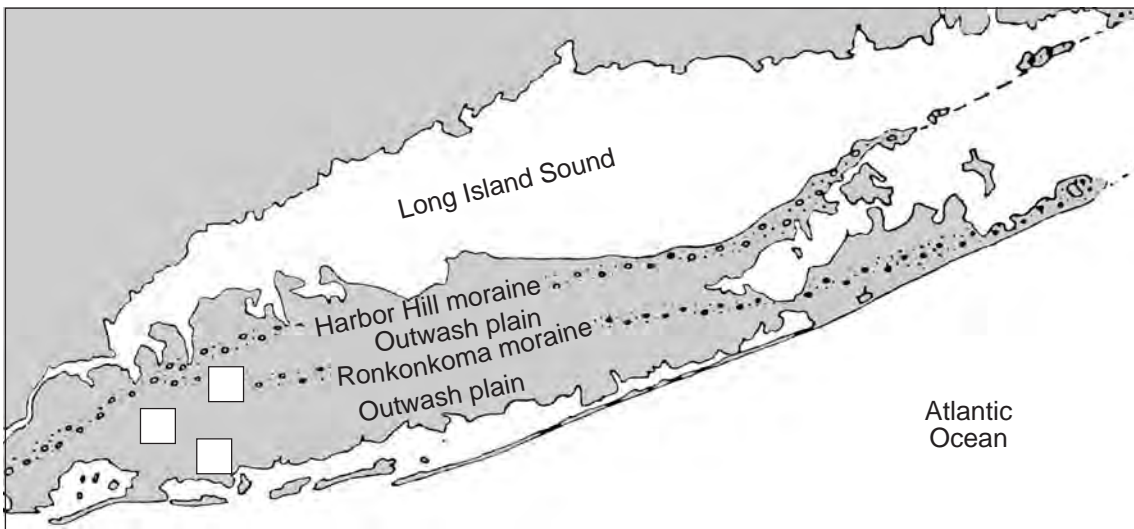

55

**For Raters
Only**

56 _____

56

57 _____

57

58 _____ **Period**

58

59 _____

59

60 _____

60

61 _____

61

62 _____ **Plate** and _____ **Plate**

62

63 _____

63

64 _____

64

65 Latitude: _____

65

Longitude: _____

**Total Score for
Part B-2**

Part C

For Raters Only

66-67

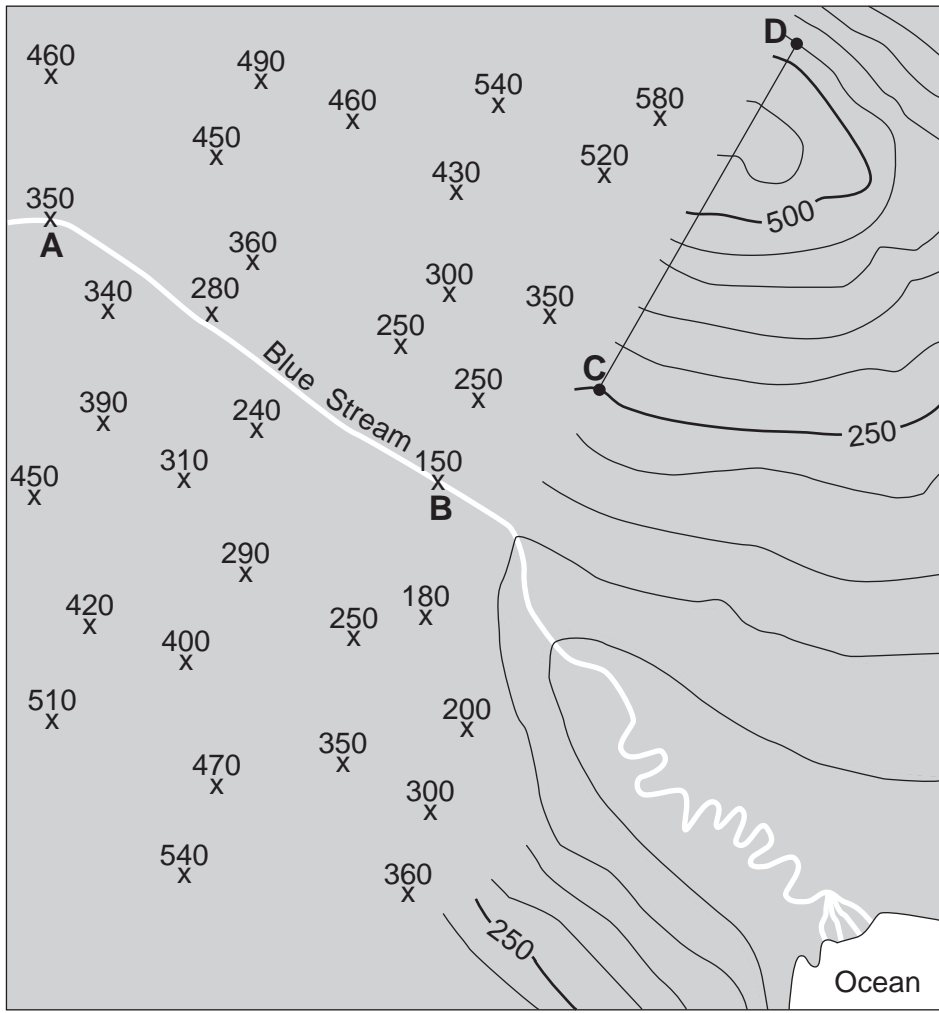

Contour interval = 50 meters

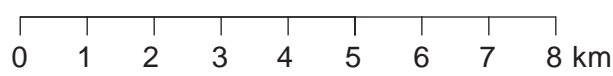

66

67

68 _____

68

69

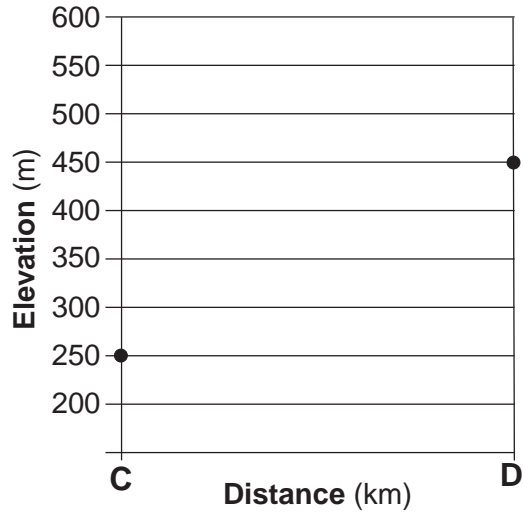

69

70

70

71

71

72

Location B

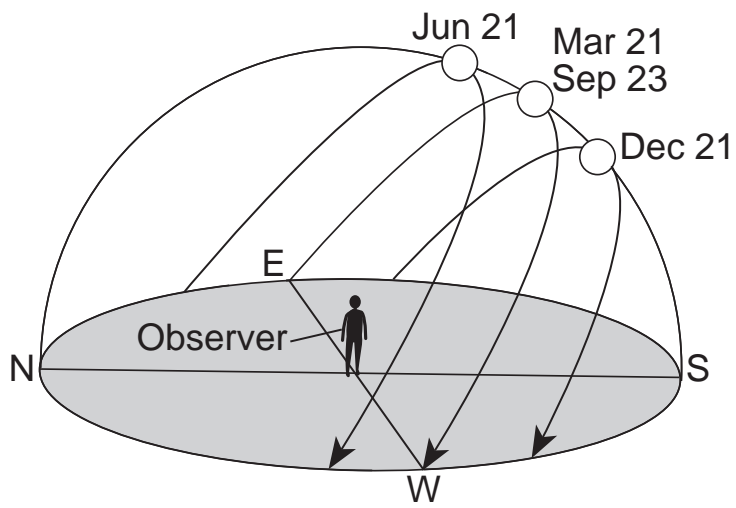

72

73

_____ h

73

74

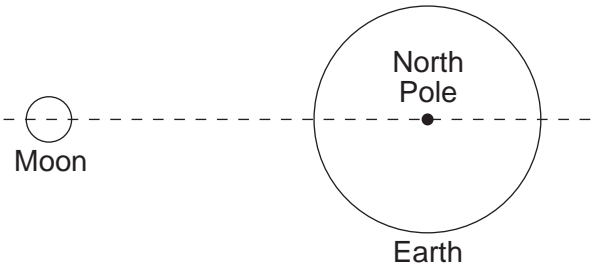

(Not drawn to scale)

74

75

75

76

_____ s

76

77

77

78

78

79

79

80

80

81

81

**For Raters
Only**

82 Air temperature: _____°F

Dewpoint: _____°F

Wind direction from: _____

Wind speed: _____ knots

Cloud cover: _____ %

82

83 Temperature: _____

Humidity: _____

83

84 _____

84

85 _____

85

**Total Score
for Part C**

FOR TEACHERS ONLY

The University of the State of New York
REGENTS HIGH SCHOOL EXAMINATION

PS-ES PHYSICAL SETTING/EARTH SCIENCE

Tuesday, June 22, 2010 — 9:15 a.m. to 12:15 p.m., only

SCORING KEY AND RATING GUIDE

Directions to the Teacher:

Refer to the directions on page 2 before rating student papers.

Updated information regarding the rating of this examination may be posted on the New York State Education Department's web site during the rating period. Check this web site <http://www.emsc.nysed.gov/osa/> and select the link "Examination Scoring Information" for any recently posted information regarding this examination. This site should be checked before the rating process for this examination begins and several times throughout the Regents examination period.

Part A and Part B-1

Allow 1 credit for each correct response.

| Part A | | | Part B-1 | |
|---------------------------------|---------------------------------|---------------------------------|---------------------------------|---------------------------------|
| 1 1 | 13 4 | 25 3 | 36 4 | 44 2 |
| 2 4 | 14 4 | 26 3 | 37 4 | 45 1 |
| 3 1 | 15 3 | 27 2 | 38 1 | 46 4 |
| 4 2 | 16 2 | 28 1 | 39 3 | 47 3 |
| 5 1 | 17 1 | 29 4 | 40 1 | 48 4 |
| 6 4 | 18 4 | 30 2 | 41 2 | 49 1 |
| 7 1 | 19 3 | 31 4 | 42 1 | 50 1 |
| 8 3 | 20 4 | 32 3 | 43 3 | |
| 9 2 | 21 2 | 33 1 | | |
| 10 1 | 22 2 | 34 2 | | |
| 11 2 | 23 1 | 35 2 | | |
| 12 2 | 24 1 | | | |

Directions to the Teacher

Follow the procedures below for scoring student answer papers for the Physical Setting/Earth Science examination. Additional information about scoring is provided in the publication *Information Booklet for Scoring Regents Examinations in the Sciences*.

Use only *red* ink or *red* pencil in rating Regents papers. Do *not* correct the student's work by making insertions or changes of any kind.

For Part A and Part B–1, indicate by means of a check mark each incorrect or omitted answer. In the box provided at the end of each part, record the number of questions the student answered correctly for that part.

At least two science teachers must participate in the scoring of each student's responses to the Part B–2 and Part C open-ended questions. Each of these teachers should be responsible for scoring a selected number of the open-ended questions on each answer paper. No one teacher is to score all the open-ended questions on a student's answer paper.

Students' responses must be scored strictly according to the Scoring Key and Rating Guide. For open-ended questions, credit may be allowed for responses other than those given in the rating guide if the response is a scientifically accurate answer to the question and demonstrates adequate knowledge as indicated by the examples in the rating guide. In the student's answer booklet, record the number of credits earned for each answer in the box printed to the right of the answer lines or spaces for that question.

Fractional credit is *not* allowed. Only whole-number credit may be given to a response. Units need not be given when the wording of the questions allows such omissions.

Raters should enter the scores earned for Part A, Part B–1, Part B–2, and Part C on the appropriate lines in the box printed on the answer booklet, and then should add these four scores and enter the total in the box labeled "Total Written Test Score." The student's score for the Earth Science Performance Test should be entered in the space provided. Then, the student's raw scores on the performance test and written test should be converted to a scale score by using the conversion chart that will be posted on the Department's web site <http://www.emsc.nysed.gov/osa/> on Tuesday, June 22, 2010. The student's scale score should be entered in the labeled box on the student's answer booklet. The scale score is the student's final examination score. On the front of the student's answer booklet, raters must enter their initials on the lines next to "Rater 1" or "Rater 2."

All student answer papers that receive a scale score of 60 through 64 **must** be scored a second time. For the second scoring, a different committee of teachers may score the student's paper or the original committee may score the paper, except that no teacher may score the same open-ended questions that he/she scored in the first rating of the paper. The school principal is responsible for assuring that the student's final examination score is based on a fair, accurate, and reliable scoring of the student's answer paper.

Because scale scores corresponding to raw scores in the conversion chart may change from one examination to another, it is crucial that for each administration, the conversion chart provided for that administration be used to determine the student's final score.

Part B–2

Allow a total of 15 credits for this part. The student must answer all questions in this part.

- 51 [1] Allow 1 credit if the centers of all five **X**s are plotted within the circles shown on the grid below and are correctly connected with a line that passes within the circles.

Note: It is recommended that an overlay be used to ensure reliability in rating.
Allow credit if a symbol other than an **X** is used.

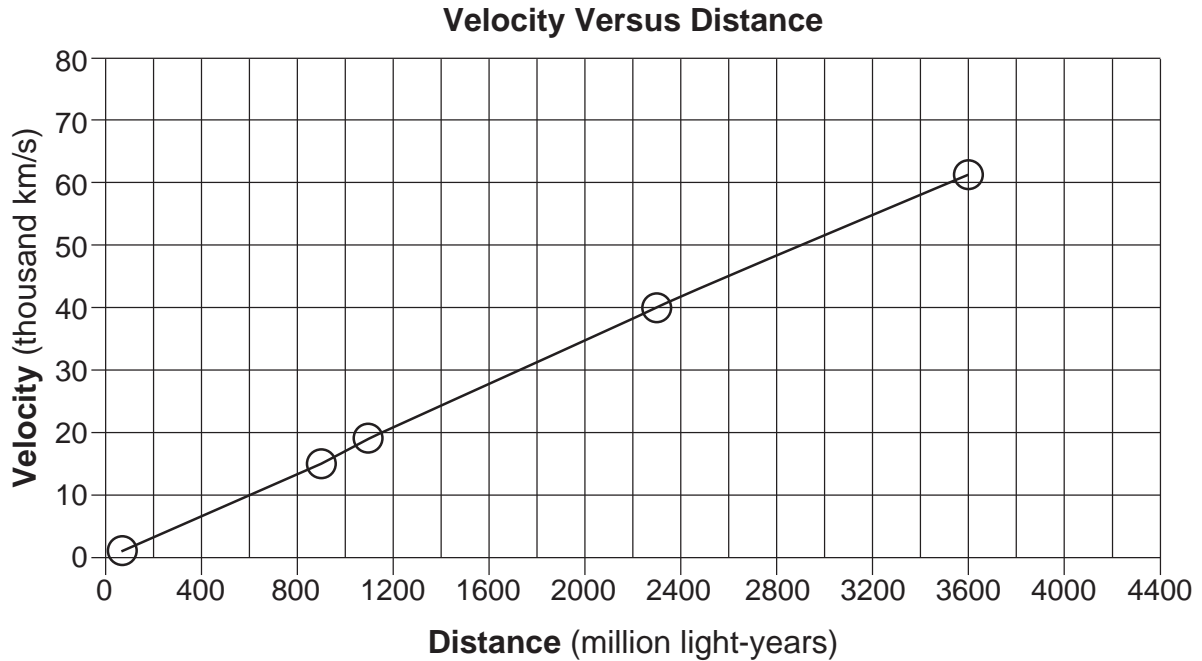

- 52 [1] Allow 1 credit. Acceptable responses include, but are not limited to:
- As the distance increases, the velocity increases.
 - The farther from Earth, the faster it moves.
 - The farther a galaxy is from Earth, the greater the velocity.
 - direct relationship

- 53 [1] Allow 1 credit for any value from 3900 to 4300 million light-years.

- 54 [1] Allow 1 credit. Acceptable responses include, but are not limited to:
- southeastward
 - from NW to SE
 - south–southeastward
 - from N to S

- 55 [1] Allow 1 credit if all three letters are placed in the correct boxes.

Example of a 1-credit response:

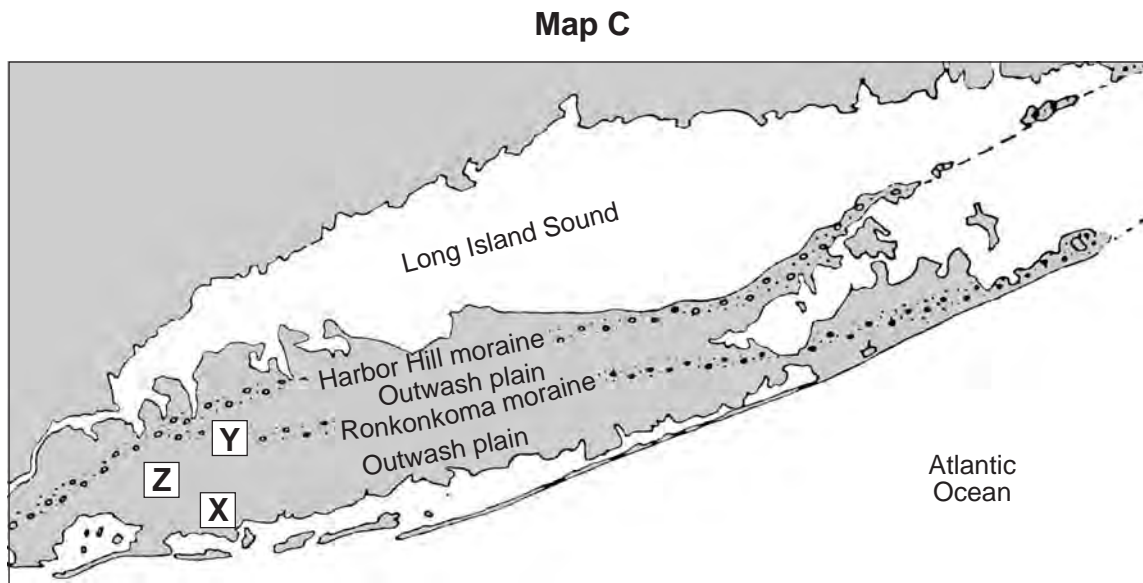

- 56 [1] Allow 1 credit for Hudson Highlands *or* Adirondack Mountains.

- 57 [1] Allow 1 credit. Acceptable responses include, but are not limited to:
- Global warming will cause glaciers to melt, which will raise the sea level.
 - New York City and Long Island could be flooded when the sea level rises.

- 58** [1] Allow 1 credit for Ordovician Period.
- 59** [1] Allow 1 credit. Acceptable responses include, but are not limited to:
- The basalt intrusion cuts across the fault.
 - The intrusion is not displaced by the fault.
 - The fault does not cut across the basalt intrusion.
- 60** [1] Allow 1 credit. Acceptable responses include, but are not limited to:
- The fossil is too old.
 - ^{14}C dating is inaccurate because very little ^{14}C is present.
 - ^{14}C has a short half-life.
- 61** [1] Allow 1 credit. Acceptable responses include, but are not limited to:
- Chimneys fell.
 - Heavy furniture overturned.
 - Anchorage suffered much damage to substantial structures.
- 62** [1] Allow 1 credit for *both* North American Plate and Pacific Plate.
- 63** [1] Allow 1 credit. Acceptable responses include, but are not limited to:
- S-waves were absorbed through the liquid outer core.
 - S-waves cannot travel through the liquid outer core.
- 64** [1] Allow 1 credit. Acceptable responses include, but are not limited to:
- tsunami
 - coastal flooding
- 65** [1] Allow 1 credit if *both* responses are correct.
- Latitude: any value from 61° N to 62° N
- Longitude: any value from 147° W to 148° W

Part C

Allow a total of 20 credits for this part. The student must answer all questions in this part.

- 66** [1] Allow 1 credit. An example of an acceptable response is shown below. If additional contour lines are drawn, all contour lines must be correct to receive credit.
- 67** [1] Allow 1 credit if the center of the **X** is within the shaded sections between the 50- and 100-meter contour lines.

Example of a 2-credit response for questions 66 and 67:

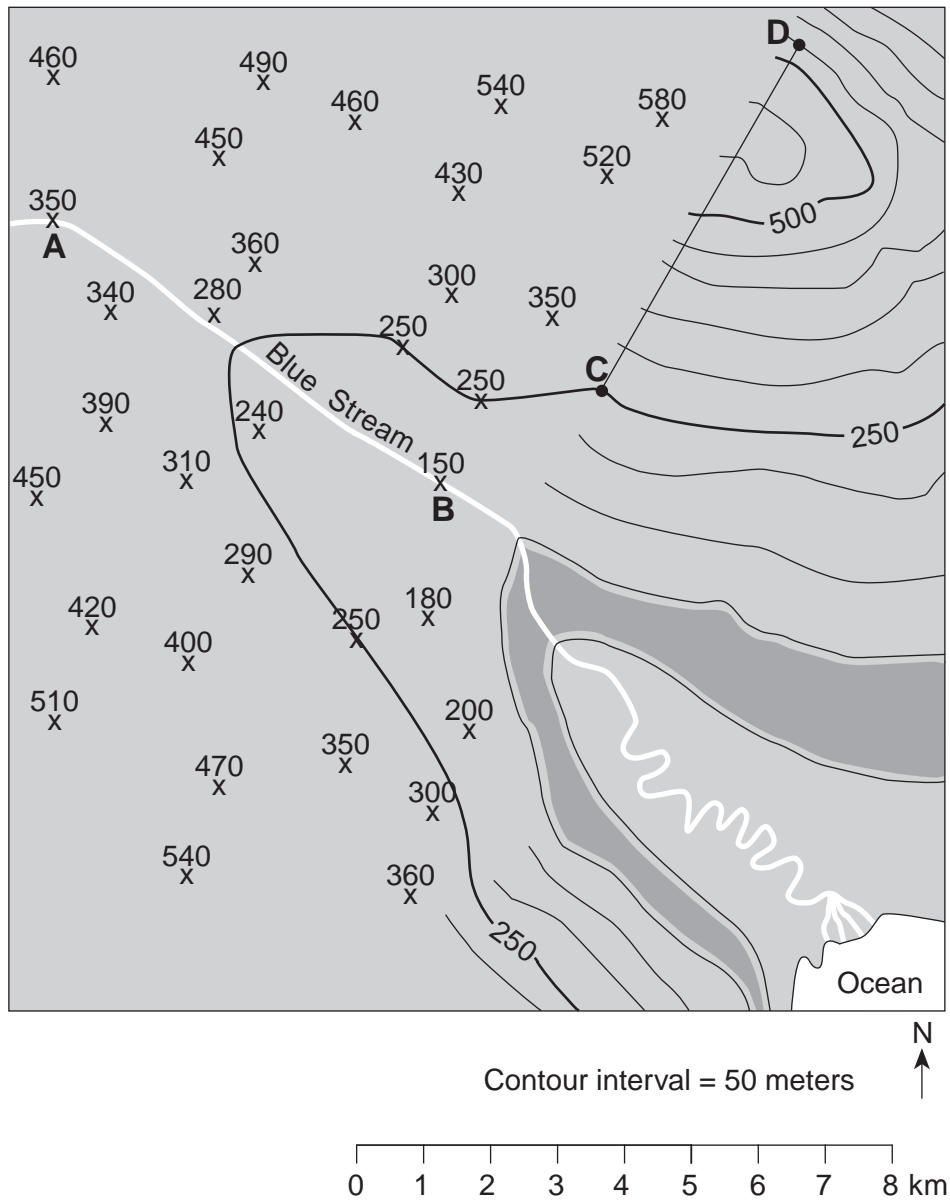

- 68 [1] Allow 1 credit for any value from 28.0 to 29.0 with the correct units. Acceptable units include, but are not limited to:
- m/km
 - meters/kilometer

- 69 [1] Allow 1 credit if the centers of all student-plotted **X**s are located within the circles shown below and are correctly connected with a line that passes within the circles. The line must have the highest elevation between 550 and 600 meters.

Note: It is recommended that an overlay be used to ensure reliability in rating.
Allow credit if a symbol other than an **X** is used.

Example of a 1-credit response:

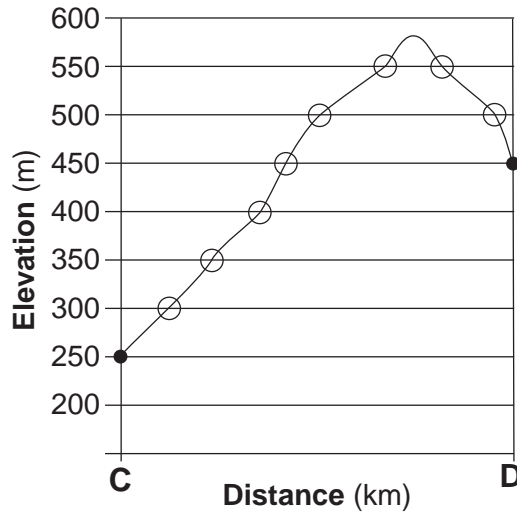

- 70 [1] Allow 1 credit. Acceptable responses include, but are not limited to:
- The Sun is directly overhead at solar noon on March 21.
 - The Sun reaches an altitude of 90° on an equinox.
 - Each apparent path of the Sun has a daylight duration of 12 hours.
- 71 [1] Allow 1 credit. Acceptable responses include, but are not limited to:
- Location *B* represents an area where the Sun is above the southern horizon at solar noon.
 - The Sun is in the southern portion of the sky.

- 72 [1] Allow 1 credit for a line drawn approximately parallel to the existing Sun's paths and within the shaded portion shown below.

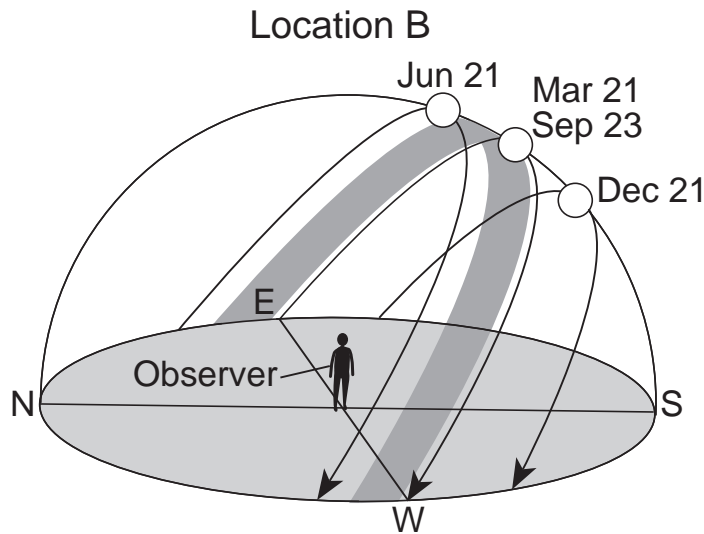

- 73 [1] Allow 1 credit for 24 h.

- 74 [1] Allow 1 credit for the center of an **X** placed within the shaded area on Earth's surface as shown in the diagram below.

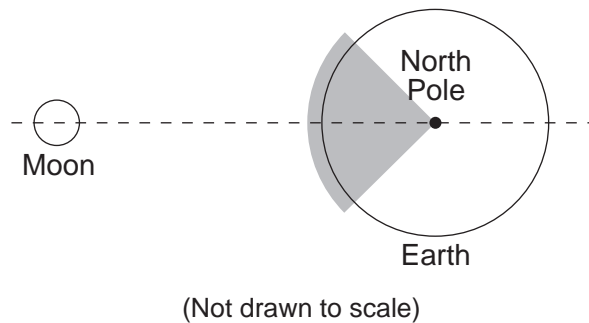

- 75 [1] Allow 1 credit. Acceptable explanations include, but are not limited to:
- The Moon gets farther away from Earth.
 - As distance between objects increases, the gravitational attraction decreases.

- 76 [1] Allow 1 credit for 2 s.

- 77 [1] Allow 1 credit. Acceptable responses include, but are not limited to:
- The Moon is closer to Earth than the Sun.
 - The Moon's gravitational attraction to Earth is greater than the Sun's.

78 [1] Allow 1 credit for calcite *or* dolomite.

79 [1] Allow 1 credit. Acceptable responses include, but are not limited to:

- Heat and pressure increase from *B* to *C*.
- Regional metamorphism is greatest at *C*.
- different grades of metamorphism

80 [1] Allow 1 credit for fine.

81 [1] Allow 1 credit. Acceptable responses include, but are not limited to:

- The oceanic crust is more dense than the continental crust.

82 [1] Allow 1 credit if all *five* responses are correct, as shown below.

Air temperature: 50 °F

Dewpoint: 44 °F

Wind direction from: SE *or* southeast

Wind speed: 10 knots

Cloud cover: 100 %

83 [1] Allow 1 credit for a correct response for temperature *and* for humidity. Acceptable responses include, but are not limited to:

Temperature:

- The air on the west side of the dry line is cooler.
- lower

Humidity:

- lower on the west side
- drier
- less

84 [1] Allow 1 credit. Acceptable responses include, but are not limited to:

- Warm air is less dense than cool air.
- Cool air is more dense than warm air.

85 [1] Allow 1 credit. Acceptable responses include, but are not limited to:

- toward the northeast
- northeastward
- eastward

Regents Examination in Physical Setting/Earth Science

June 2010

Chart for Converting Total Test Raw Scores to Final Examination Scores (Scale Scores)

The *Chart for Determining the Final Examination Score for the June 2010 Regents Examination in Physical Setting/Earth Science* will be posted on the Department's web site <http://www.emsc.nysed.gov/osa/> on Tuesday, June 22, 2010. Conversion charts provided for previous administrations of the Regents Examination in Physical Setting/Earth Science must NOT be used to determine students' final scores for this administration.

Submitting Online Teacher Evaluations of the Test to the Department

Suggestions and feedback from teachers provide an important contribution to the test development process. The Department provides an online evaluation form for State assessments. It contains spaces for teachers to respond to several specific questions and to make suggestions. Instructions for completing the evaluation form are as follows:

1. Go to www.emsc.nysed.gov/osa/exameval.
2. Select the test title.
3. Complete the required demographic fields.
4. Complete each evaluation question and provide comments in the space provided.
5. Click the SUBMIT button at the bottom of the page to submit the completed form.

Map to Core Curriculum

| June 2010 Physical Setting/Earth Science | | | |
|---|---|--|---|
| Question Numbers | | | |
| Key Ideas/Performance Indicators | Part A | Part B | Part C |
| Standard 1 | | | |
| Math Key Idea 1 | | 51 | 68, 76 |
| Math Key Idea 2 | 9, 26, 31, 35 | 49, 50, 52, 53 | |
| Math Key Idea 3 | | | 66, 69 |
| Science Inquiry Key Idea 1 | 3, 5, 6, 12, 13, 14, 17, 22, 23, 28 | 39, 42, 54, 63 | 70, 77, 81, 84 |
| Science Inquiry Key Idea 2 | | | |
| Science Inquiry Key Idea 3 | 2, 4, 5, 7, 8, 20, 21, 25, 27, 29, 31 | 40, 41, 43, 44, 45, 56, 58, 60, 62 | 68, 70, 78, 79, 80, 82, 83 |
| Engineering Design Key Idea 1 | | | |
| Standard 2 | | | |
| Key Idea 1 | | 46 | |
| Key Idea 2 | | | |
| Key Idea 3 | | 64 | 67 |
| Standard 6 | | | |
| Key Idea 1 | 10, 19, 33 | 38, 39, 42, 47, 48, 59, 63 | 74, 77, 79, 81 |
| Key Idea 2 | 1, 15, 22, 24, 25, 26, 27, 28, 29, 30, 32, 33, 34, 35 | 36, 37, 38, 39, 40, 41, 42, 43, 44, 45, 46, 47, 48, 49, 50, 54, 55, 59, 61, 62, 65 | 66, 67, 68, 69, 70, 71, 72, 73, 74, 79, 80, 82, 83, 85 |
| Key Idea 3 | | 41, 60 | |
| Key Idea 4 | | | 75 |
| Key Idea 5 | 3, 11, 12, 16, 19, 32, 34 | 55 | 70, 71, 75, 85 |
| Key Idea 6 | 17 | 57 | |
| Standard 7 | | | |
| Key Idea 1 | | | |
| Key Idea 2 | | 64 | |
| Standard 4 | | | |
| Key Idea 1 | 1, 2, 3, 4, 5, 6, 7, 10, 15, 23, 26, 27, 34, 35 | 41, 48, 49, 50, 51, 52, 53, 58, 59, 60, 65 | 70, 71, 72, 73, 74, 75, 76, 77 |
| Key Idea 2 | 8, 9, 11, 12, 13, 14, 16, 17, 18, 22, 24, 25, 28, 29, 32, 33 | 36, 37, 38, 39, 42, 43, 44, 45, 46, 47, 54, 55, 56, 57, 61, 62, 63, 64 | 66, 67, 68, 69, 73, 81, 82, 83, 84, 85 |
| Key Idea 3 | 19, 20, 21, 30, 31 | 40 | 78, 79, 80 |
| Reference Tables | | | |
| ESRT 2010 Edition (Revised) | 2, 4, 5, 7, 8, 9, 18, 19, 20, 21, 25, 27, 29, 31 | 40, 41, 44, 45, 56, 58, 60, 62 | 68, 78, 80, 82, 83 |

Regents Examination in Physical Setting/Earth Science – June 2010

Chart for Converting Total Test Raw Scores to Final Examination Scores (Scale Scores)

(Not to be used for the Braille Edition)

To determine the student's final score, locate the student's Total Performance Test Score across the top of the chart and the Total Written Test Score down the side of the chart. The point where the two scores intersect is the student's final examination score. For example, a student receiving a Total Performance Test Score of 10 and Total Written Test Score of 71 would receive a final examination score of 90.

| | | Total Performance Test Score | | | | | | | | | | | | | | | | |
|--------------------------|----|-------------------------------------|----|----|----|----|----|----|----|----|----|----|----|----|----|----|----|----|
| | | 16 | 15 | 14 | 13 | 12 | 11 | 10 | 9 | 8 | 7 | 6 | 5 | 4 | 3 | 2 | 1 | 0 |
| Total Written Test Score | 85 | 100 | 99 | 99 | 99 | 98 | 98 | 97 | 96 | 96 | 95 | 94 | 93 | 91 | 90 | 88 | 87 | 85 |
| | 84 | 99 | 99 | 98 | 98 | 98 | 97 | 96 | 96 | 95 | 94 | 93 | 92 | 91 | 89 | 88 | 86 | 84 |
| | 83 | 99 | 99 | 98 | 98 | 98 | 97 | 96 | 96 | 95 | 94 | 93 | 92 | 91 | 89 | 88 | 86 | 84 |
| | 82 | 98 | 98 | 98 | 97 | 97 | 96 | 95 | 95 | 94 | 93 | 92 | 91 | 90 | 88 | 87 | 85 | 83 |
| | 81 | 98 | 98 | 98 | 97 | 97 | 96 | 95 | 95 | 94 | 93 | 92 | 91 | 90 | 88 | 87 | 85 | 83 |
| | 80 | 97 | 97 | 97 | 96 | 96 | 95 | 95 | 94 | 93 | 92 | 91 | 90 | 89 | 88 | 86 | 84 | 82 |
| | 79 | 97 | 97 | 97 | 96 | 96 | 95 | 95 | 94 | 93 | 92 | 91 | 90 | 89 | 88 | 86 | 84 | 82 |
| | 78 | 97 | 96 | 96 | 95 | 95 | 94 | 94 | 93 | 92 | 91 | 90 | 89 | 88 | 87 | 85 | 83 | 82 |
| | 77 | 96 | 95 | 95 | 95 | 94 | 94 | 93 | 92 | 91 | 91 | 89 | 88 | 87 | 86 | 84 | 83 | 81 |
| | 76 | 96 | 95 | 95 | 95 | 94 | 94 | 93 | 92 | 91 | 91 | 89 | 88 | 87 | 86 | 84 | 83 | 81 |
| | 75 | 95 | 95 | 94 | 94 | 93 | 93 | 92 | 91 | 91 | 90 | 89 | 88 | 86 | 85 | 83 | 82 | 80 |
| | 74 | 94 | 94 | 93 | 93 | 92 | 92 | 91 | 90 | 90 | 89 | 88 | 87 | 86 | 84 | 83 | 81 | 79 |
| | 73 | 94 | 94 | 93 | 93 | 92 | 92 | 91 | 90 | 90 | 89 | 88 | 87 | 86 | 84 | 83 | 81 | 79 |
| | 72 | 93 | 93 | 92 | 92 | 92 | 91 | 90 | 90 | 89 | 88 | 87 | 86 | 85 | 83 | 82 | 80 | 78 |
| | 71 | 92 | 92 | 92 | 91 | 91 | 90 | 90 | 89 | 88 | 87 | 86 | 85 | 84 | 82 | 81 | 79 | 77 |
| | 70 | 92 | 92 | 92 | 91 | 91 | 90 | 90 | 89 | 88 | 87 | 86 | 85 | 84 | 82 | 81 | 79 | 77 |
| | 69 | 92 | 91 | 91 | 90 | 90 | 89 | 89 | 88 | 87 | 86 | 85 | 84 | 83 | 82 | 80 | 78 | 77 |
| | 68 | 91 | 90 | 90 | 89 | 89 | 88 | 88 | 87 | 86 | 85 | 84 | 83 | 82 | 81 | 79 | 77 | 76 |
| | 67 | 90 | 90 | 89 | 89 | 88 | 88 | 87 | 86 | 85 | 85 | 84 | 83 | 82 | 81 | 80 | 78 | 75 |
| | 66 | 89 | 89 | 88 | 88 | 87 | 87 | 86 | 85 | 85 | 84 | 83 | 82 | 80 | 79 | 77 | 76 | 74 |
| | 65 | 89 | 89 | 88 | 88 | 87 | 87 | 86 | 85 | 85 | 84 | 83 | 82 | 80 | 79 | 77 | 76 | 74 |
| 64 | 88 | 88 | 87 | 87 | 86 | 86 | 85 | 85 | 84 | 83 | 82 | 81 | 80 | 78 | 77 | 75 | 73 | |
| 63 | 87 | 87 | 87 | 86 | 86 | 85 | 84 | 84 | 83 | 82 | 81 | 80 | 79 | 77 | 76 | 74 | 72 | |
| 62 | 86 | 86 | 86 | 85 | 85 | 84 | 84 | 83 | 82 | 81 | 80 | 79 | 78 | 77 | 75 | 73 | 71 | |
| 61 | 86 | 85 | 85 | 84 | 84 | 83 | 83 | 82 | 81 | 80 | 79 | 78 | 77 | 76 | 74 | 72 | 71 | |
| 60 | 85 | 84 | 84 | 84 | 83 | 82 | 82 | 81 | 80 | 79 | 78 | 77 | 76 | 75 | 73 | 72 | 70 | |
| 59 | 84 | 84 | 83 | 83 | 82 | 82 | 81 | 80 | 80 | 79 | 78 | 77 | 75 | 74 | 72 | 71 | 69 | |
| 58 | 83 | 83 | 82 | 82 | 81 | 81 | 80 | 79 | 79 | 78 | 77 | 76 | 74 | 73 | 71 | 70 | 68 | |
| 57 | 82 | 82 | 81 | 81 | 81 | 80 | 79 | 79 | 78 | 77 | 76 | 75 | 74 | 72 | 71 | 69 | 67 | |
| 56 | 81 | 81 | 81 | 80 | 80 | 79 | 78 | 78 | 77 | 76 | 75 | 74 | 73 | 71 | 70 | 68 | 66 | |
| 55 | 80 | 80 | 80 | 79 | 79 | 78 | 78 | 77 | 76 | 75 | 74 | 73 | 72 | 71 | 69 | 67 | 65 | |
| 54 | 80 | 79 | 79 | 78 | 78 | 77 | 77 | 76 | 75 | 74 | 73 | 72 | 71 | 70 | 68 | 66 | 65 | |
| 53 | 79 | 78 | 78 | 78 | 77 | 77 | 76 | 75 | 74 | 74 | 72 | 71 | 70 | 69 | 67 | 66 | 64 | |
| 52 | 78 | 78 | 77 | 77 | 76 | 76 | 75 | 74 | 74 | 73 | 72 | 71 | 69 | 68 | 66 | 65 | 63 | |
| 51 | 77 | 77 | 76 | 76 | 75 | 75 | 74 | 73 | 73 | 72 | 71 | 70 | 69 | 67 | 66 | 64 | 62 | |
| 50 | 76 | 76 | 75 | 75 | 75 | 74 | 73 | 73 | 72 | 71 | 70 | 69 | 68 | 66 | 65 | 63 | 61 | |
| 49 | 75 | 75 | 75 | 74 | 74 | 73 | 73 | 72 | 71 | 70 | 69 | 68 | 67 | 65 | 64 | 62 | 60 | |
| 48 | 75 | 74 | 74 | 73 | 73 | 72 | 72 | 71 | 70 | 69 | 68 | 67 | 66 | 65 | 63 | 61 | 60 | |
| 47 | 74 | 73 | 73 | 72 | 72 | 71 | 71 | 70 | 69 | 68 | 67 | 66 | 65 | 64 | 62 | 60 | 59 | |
| 46 | 73 | 73 | 72 | 72 | 71 | 71 | 70 | 69 | 68 | 68 | 67 | 65 | 64 | 63 | 61 | 60 | 58 | |
| 45 | 72 | 72 | 71 | 71 | 70 | 70 | 69 | 68 | 68 | 67 | 66 | 65 | 63 | 62 | 60 | 59 | 57 | |
| 44 | 71 | 71 | 70 | 70 | 69 | 69 | 68 | 68 | 67 | 66 | 65 | 64 | 63 | 61 | 60 | 58 | 56 | |

**Final Examination Scores
June 2010 Examination in Physical Setting/Earth Science – continued**

Total Performance Test Score

| | 16 | 15 | 14 | 13 | 12 | 11 | 10 | 9 | 8 | 7 | 6 | 5 | 4 | 3 | 2 | 1 | 0 |
|-----------|-----------|-----------|-----------|-----------|-----------|-----------|-----------|----------|----------|----------|----------|----------|----------|----------|----------|----------|----------|
| 43 | 70 | 70 | 70 | 69 | 69 | 68 | 67 | 67 | 66 | 65 | 64 | 63 | 62 | 60 | 59 | 57 | 55 |
| 42 | 69 | 68 | 68 | 67 | 67 | 66 | 66 | 65 | 64 | 63 | 62 | 61 | 60 | 59 | 57 | 55 | 54 |
| 41 | 68 | 67 | 67 | 67 | 66 | 65 | 65 | 64 | 63 | 62 | 61 | 60 | 59 | 58 | 56 | 55 | 53 |
| 40 | 67 | 67 | 66 | 66 | 65 | 65 | 64 | 63 | 63 | 62 | 61 | 60 | 58 | 57 | 55 | 54 | 52 |
| 39 | 66 | 66 | 65 | 65 | 64 | 64 | 63 | 62 | 62 | 61 | 60 | 59 | 57 | 56 | 54 | 53 | 51 |
| 38 | 65 | 65 | 64 | 64 | 64 | 63 | 62 | 62 | 61 | 60 | 59 | 58 | 57 | 55 | 54 | 52 | 50 |
| 37 | 63 | 63 | 63 | 62 | 62 | 61 | 61 | 60 | 59 | 58 | 57 | 56 | 55 | 54 | 52 | 50 | 48 |
| 36 | 63 | 62 | 62 | 61 | 61 | 60 | 60 | 59 | 58 | 57 | 56 | 55 | 54 | 53 | 51 | 49 | 48 |
| 35 | 62 | 61 | 61 | 61 | 60 | 60 | 59 | 58 | 57 | 57 | 55 | 54 | 53 | 52 | 50 | 49 | 47 |
| 34 | 61 | 61 | 60 | 60 | 59 | 59 | 58 | 57 | 57 | 56 | 55 | 54 | 52 | 51 | 49 | 48 | 46 |
| 33 | 59 | 59 | 58 | 58 | 58 | 57 | 56 | 56 | 55 | 54 | 53 | 52 | 51 | 49 | 48 | 46 | 44 |
| 32 | 58 | 58 | 58 | 57 | 57 | 56 | 56 | 55 | 54 | 53 | 52 | 51 | 50 | 48 | 47 | 45 | 43 |
| 31 | 58 | 57 | 57 | 56 | 56 | 55 | 55 | 54 | 53 | 52 | 51 | 50 | 49 | 48 | 46 | 44 | 43 |
| 30 | 56 | 56 | 55 | 55 | 54 | 54 | 53 | 52 | 51 | 51 | 50 | 48 | 47 | 46 | 44 | 43 | 41 |
| 29 | 55 | 55 | 54 | 54 | 53 | 53 | 52 | 51 | 51 | 50 | 49 | 48 | 46 | 45 | 43 | 42 | 40 |
| 28 | 53 | 53 | 53 | 52 | 52 | 51 | 50 | 50 | 49 | 48 | 47 | 46 | 45 | 43 | 42 | 40 | 38 |
| 27 | 52 | 52 | 52 | 51 | 51 | 50 | 50 | 49 | 48 | 47 | 46 | 45 | 44 | 43 | 41 | 39 | 37 |
| 26 | 52 | 51 | 51 | 50 | 50 | 49 | 49 | 48 | 47 | 46 | 45 | 44 | 43 | 42 | 40 | 38 | 37 |
| 25 | 50 | 50 | 49 | 49 | 48 | 48 | 47 | 46 | 46 | 45 | 44 | 43 | 41 | 40 | 38 | 37 | 35 |
| 24 | 49 | 49 | 48 | 48 | 47 | 47 | 46 | 45 | 45 | 44 | 43 | 42 | 40 | 39 | 37 | 36 | 34 |
| 23 | 47 | 47 | 47 | 46 | 46 | 45 | 44 | 44 | 43 | 42 | 41 | 40 | 39 | 37 | 36 | 34 | 32 |
| 22 | 46 | 46 | 46 | 45 | 45 | 44 | 44 | 43 | 42 | 41 | 40 | 39 | 38 | 37 | 35 | 33 | 31 |
| 21 | 45 | 44 | 44 | 44 | 43 | 43 | 42 | 41 | 40 | 40 | 38 | 37 | 36 | 35 | 33 | 32 | 30 |
| 20 | 44 | 44 | 43 | 43 | 42 | 42 | 41 | 40 | 40 | 39 | 38 | 37 | 35 | 34 | 32 | 31 | 29 |
| 19 | 42 | 42 | 41 | 41 | 41 | 40 | 39 | 39 | 38 | 37 | 36 | 35 | 34 | 32 | 31 | 29 | 27 |
| 18 | 41 | 41 | 41 | 40 | 40 | 39 | 39 | 38 | 37 | 36 | 35 | 34 | 33 | 31 | 30 | 28 | 26 |
| 17 | 40 | 39 | 39 | 38 | 38 | 37 | 37 | 36 | 35 | 34 | 33 | 32 | 31 | 30 | 28 | 26 | 25 |
| 16 | 38 | 38 | 37 | 37 | 36 | 36 | 35 | 34 | 34 | 33 | 32 | 31 | 29 | 28 | 26 | 25 | 23 |
| 15 | 37 | 37 | 36 | 36 | 35 | 35 | 34 | 34 | 33 | 32 | 31 | 30 | 29 | 27 | 26 | 24 | 22 |
| 14 | 35 | 35 | 35 | 34 | 34 | 33 | 33 | 32 | 31 | 30 | 29 | 28 | 27 | 26 | 24 | 22 | 20 |
| 13 | 34 | 33 | 33 | 33 | 32 | 31 | 31 | 30 | 29 | 28 | 27 | 26 | 25 | 24 | 22 | 21 | 19 |
| 12 | 33 | 33 | 32 | 32 | 31 | 31 | 30 | 29 | 29 | 28 | 27 | 26 | 24 | 23 | 21 | 20 | 18 |
| 11 | 31 | 31 | 30 | 30 | 30 | 29 | 28 | 28 | 27 | 26 | 25 | 24 | 23 | 21 | 20 | 18 | 16 |
| 10 | 29 | 29 | 29 | 28 | 28 | 27 | 27 | 26 | 25 | 24 | 23 | 22 | 21 | 20 | 18 | 16 | 14 |
| 9 | 29 | 28 | 28 | 27 | 27 | 26 | 26 | 25 | 24 | 23 | 22 | 21 | 20 | 19 | 17 | 15 | 14 |
| 8 | 27 | 27 | 26 | 26 | 25 | 25 | 24 | 23 | 23 | 22 | 21 | 20 | 18 | 17 | 15 | 14 | 12 |
| 7 | 25 | 25 | 24 | 24 | 24 | 23 | 22 | 22 | 21 | 20 | 19 | 18 | 17 | 15 | 14 | 12 | 10 |
| 6 | 24 | 24 | 24 | 23 | 23 | 22 | 22 | 21 | 20 | 19 | 18 | 17 | 16 | 14 | 13 | 11 | 9 |
| 5 | 23 | 22 | 22 | 21 | 21 | 20 | 20 | 19 | 18 | 17 | 16 | 15 | 14 | 13 | 11 | 9 | 8 |
| 4 | 21 | 21 | 20 | 20 | 19 | 19 | 18 | 17 | 17 | 16 | 15 | 14 | 12 | 11 | 9 | 8 | 6 |
| 3 | 19 | 19 | 19 | 18 | 18 | 17 | 16 | 16 | 15 | 14 | 13 | 12 | 11 | 9 | 8 | 6 | 4 |
| 2 | 18 | 18 | 18 | 17 | 17 | 16 | 16 | 15 | 14 | 13 | 12 | 11 | 10 | 9 | 7 | 5 | 3 |
| 1 | 17 | 16 | 16 | 16 | 15 | 14 | 14 | 13 | 12 | 11 | 10 | 9 | 8 | 7 | 5 | 4 | 2 |
| 0 | 15 | 15 | 14 | 14 | 13 | 13 | 12 | 11 | 11 | 10 | 9 | 8 | 6 | 5 | 3 | 2 | 0 |