

The University of the State of New York
REGENTS HIGH SCHOOL EXAMINATION

PHYSICAL SETTING
EARTH SCIENCE

Friday, June 20, 2008 — 1:15 to 4:15 p.m., only

This is a test of your knowledge of Earth science. Use that knowledge to answer all questions in this examination. Some questions may require the use of the *Earth Science Reference Tables*. The *Earth Science Reference Tables* are supplied separately. Be certain you have a copy of the *2001 Edition (Revised November 2006)* of these reference tables before you begin the examination.

Your answer sheet for Part A and Part B–1 is the last page of this examination booklet. Turn to the last page and fold it along the perforations. Then, slowly and carefully, tear off your answer sheet and fill in the heading.

The answers to the questions in Part B–2 and Part C are to be written in your separate answer booklet. Be sure to fill in the heading on the front of your answer booklet.

You are to answer *all* questions in all parts of this examination according to the directions provided in the examination booklet. Record your answers to the Part A and Part B–1 multiple-choice questions on your separate answer sheet. Write your answers to the Part B–2 and Part C questions in your answer booklet. All work should be written in pen, except for graphs and drawings, which should be done in pencil. You may use scrap paper to work out the answers to the questions, but be sure to record all your answers on your separate answer sheet and in your answer booklet.

When you have completed the examination, you must sign the statement printed at the end of your separate answer sheet, indicating that you had no unlawful knowledge of the questions or answers prior to the examination and that you have neither given nor received assistance in answering any of the questions during the examination. Your answer sheet and answer booklet cannot be accepted if you fail to sign this declaration.

Notice. . .

A four-function or scientific calculator and a copy of the *2001 Earth Science Reference Tables (Revised November 2006)* must be available for you to use while taking this examination.

The use of any communications device is strictly prohibited when taking this examination. If you use any communications device, no matter how briefly, your examination will be invalidated and no score will be calculated for you.

DO NOT OPEN THIS EXAMINATION BOOKLET UNTIL THE SIGNAL IS GIVEN.

Part A

Answer all questions in this part.

Directions (1–35): For *each* statement or question, write on your separate answer sheet the *number* of the word or expression that, of those given, best completes the statement or answers the question. Some questions may require the use of the *Earth Science Reference Tables*.

1 As viewed from Earth, most stars appear to move across the sky each night because

- (1) Earth revolves around the Sun
- (2) Earth rotates on its axis
- (3) stars orbit around Earth
- (4) stars revolve around the center of the galaxy

2 The star *Algol* is estimated to have approximately the same luminosity as the star *Aldebaran* and approximately the same temperature as the star *Rigel*. *Algol* is best classified as a

- (1) main sequence star
- (2) red giant star
- (3) white dwarf star
- (4) red dwarf star

3 The explosion associated with the Big Bang theory and the formation of the universe is inferred to have occurred how many billion years ago?

- (1) less than 1
- (2) 2.5
- (3) 4.6
- (4) over 10

4 The diagram below represents the constellation Lyra.

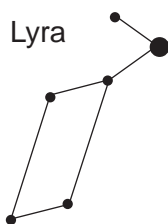

Which statement best explains why Lyra is visible to an observer in New York State at midnight in July but *not* visible at midnight in December?

- (1) Earth spins on its axis.
- (2) Earth orbits the Sun.
- (3) Lyra spins on its axis.
- (4) Lyra orbits Earth.

5 The Coriolis effect provides evidence that Earth

- (1) rotates on its axis
- (2) revolves around the Sun
- (3) undergoes cyclic tidal changes
- (4) has a slightly eccentric orbit

6 The altitude of the ozone layer near the South Pole is 20 kilometers above sea level. Which temperature zone of the atmosphere contains this ozone layer?

- (1) troposphere
- (2) stratosphere
- (3) mesosphere
- (4) thermosphere

7 A low-pressure system in the Northern Hemisphere has a surface air-circulation pattern that is

- (1) clockwise and away from the center
- (2) clockwise and toward the center
- (3) counterclockwise and away from the center
- (4) counterclockwise and toward the center

8 Air masses are identified on the basis of temperature and

- (1) type of precipitation
- (2) wind velocity
- (3) moisture content
- (4) atmospheric transparency

9 During some winters in the Finger Lakes region of New York State, the lake water remains unfrozen even though the land around the lakes is frozen and covered with snow. The primary cause of this difference is that water

- (1) gains heat during evaporation
- (2) is at a lower elevation
- (3) has a higher specific heat
- (4) reflects more radiation

10 The reaction below represents an energy-producing process.

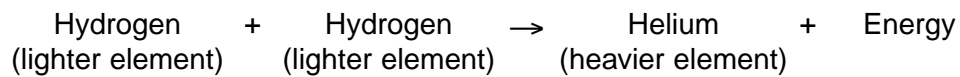

The reaction represents how energy is produced

- (1) in the Sun by fusion
- (2) when water condenses in Earth's atmosphere
- (3) from the movement of crustal plates
- (4) during nuclear decay

11 The diagram below shows the spectral lines for an element.

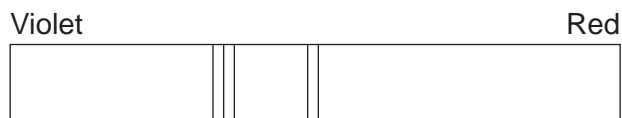

Which diagram best represents the spectral lines of this element when its light is observed coming from a star that is moving away from Earth?

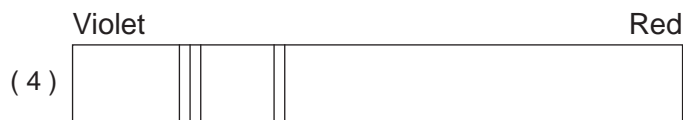

12 Diagram 1 shows the Moon in its orbit at four positions labeled A, B, C, and D. Diagram 2 shows a phase of the Moon as viewed from New York State.

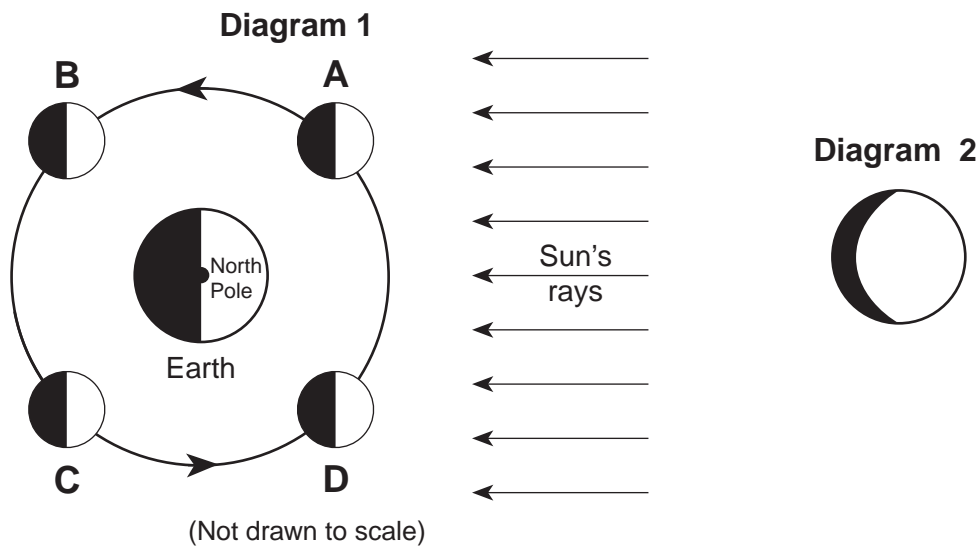

At which labeled Moon position would the phase of the Moon shown in diagram 2 be observed from New York State?

- (1) A
- (2) B
- (3) C
- (4) D

13 The diagram below shows an observer measuring the altitude of *Polaris*.

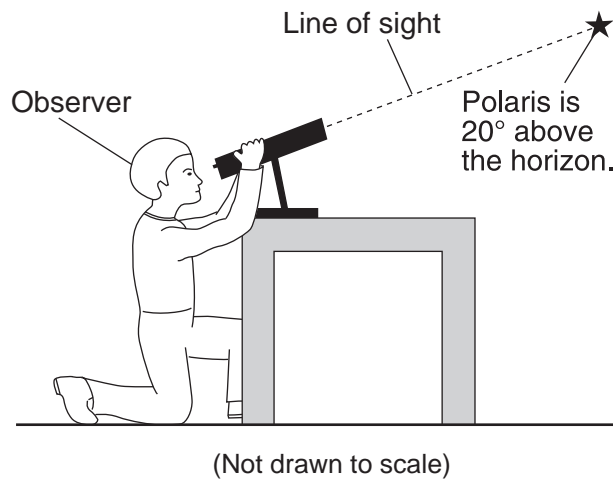

What is the latitude of the observer?

- (1) 20° N
- (2) 20° S
- (3) 70° N
- (4) 70° S

14 The weather instrument shown below can be used to determine dewpoint.

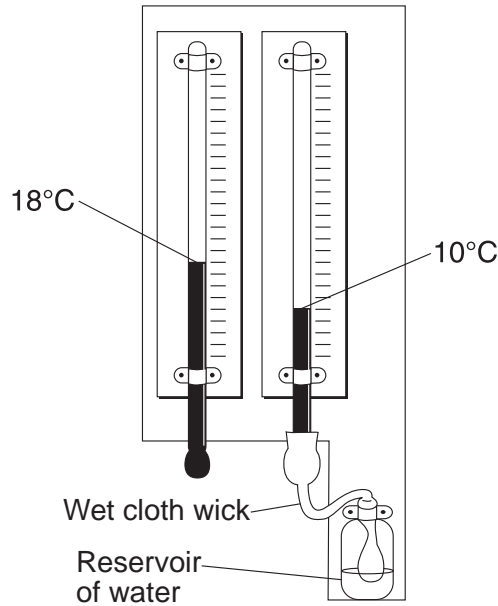

Based on the values shown, the dewpoint is

- (1) -5°C
- (2) 2°C
- (3) 8°C
- (4) 33°C

15 Which arrangement of the Sun, the Moon, and Earth results in the highest high tides, and the lowest low tides on Earth? (Diagrams are not drawn to scale.)

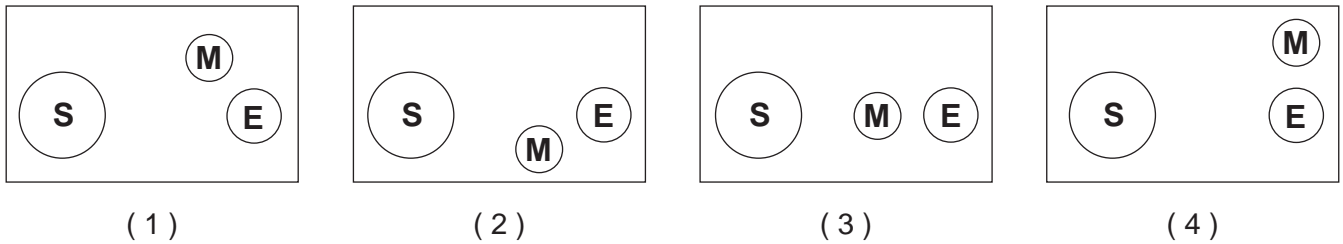

16 Which station model correctly represents the weather conditions in an area that is experiencing winds from the northeast at 25 knots and has had a steady drop in barometric pressure of 2.7 millibars during the last three hours?

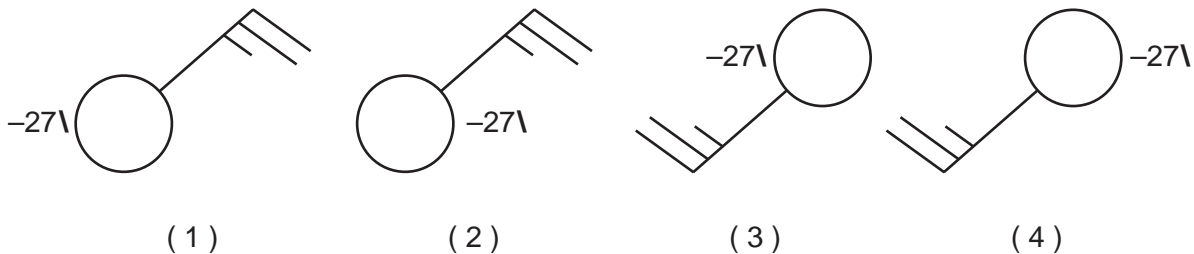

17 The diagram below shows weather instruments A and B.

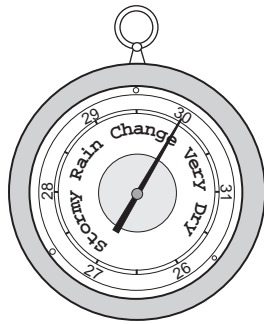

A

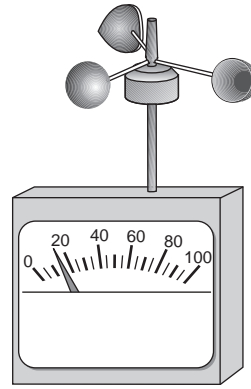

B

Which table correctly indicates the name of the weather instrument and the weather variable that it measures?

Instrument		Weather Variable Measured
Letter	Name	
A	thermometer	humidity
B	wind vane	wind direction

(1)

Instrument		Weather Variable Measured
Letter	Name	
A	barometer	wind speed
B	anemometer	air pressure

(3)

Instrument		Weather Variable Measured
Letter	Name	
A	thermometer	wind direction
B	wind vane	humidity

(2)

Instrument		Weather Variable Measured
Letter	Name	
A	barometer	air pressure
B	anemometer	wind speed

(4)

18 Which ocean current carries cool water toward Earth's equator?

- (1) Alaska Current
- (2) East Australia Current
- (3) Peru Current
- (4) North Atlantic Current

19 Equal areas of which surface would most likely absorb the most insolation?

- (1) smooth, white surface
- (2) rough, white surface
- (3) smooth, black surface
- (4) rough, black surface

20 On the map below, the darkened areas represent locations where living corals currently exist. The arrow points to a location where coral fossils have been found in Devonian-age bedrock in New York State.

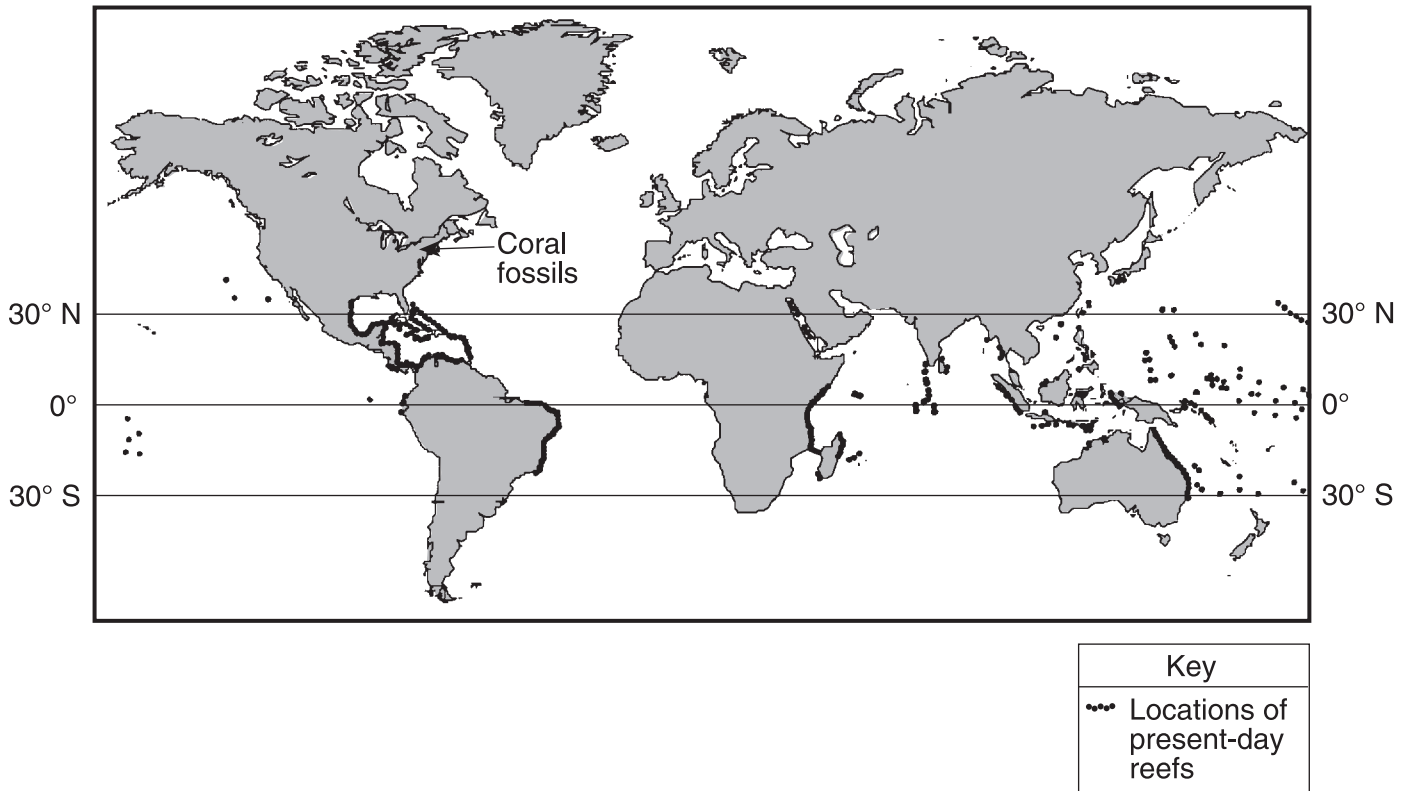

Devonian-age coral fossils found in some New York State bedrock are *not* located in the same general region that present-day corals are living because during the Devonian Period

- (1) corals migrated to New York State
- (2) corals lived everywhere on Earth
- (3) New York State was closer to the equator
- (4) New York State had a colder climate

21 Which index fossil may be found in the surface bedrock near Ithaca, New York?



Elliptocephala
(1)

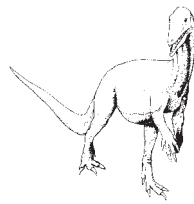

Coelophysis
(2)



Bothriolepis
(3)



Maclurites
(4)

- 22 The cross sections below represent three widely separated outcrops of exposed bedrock. Letters A, B, C, and D represent fossils found in the rock layers.

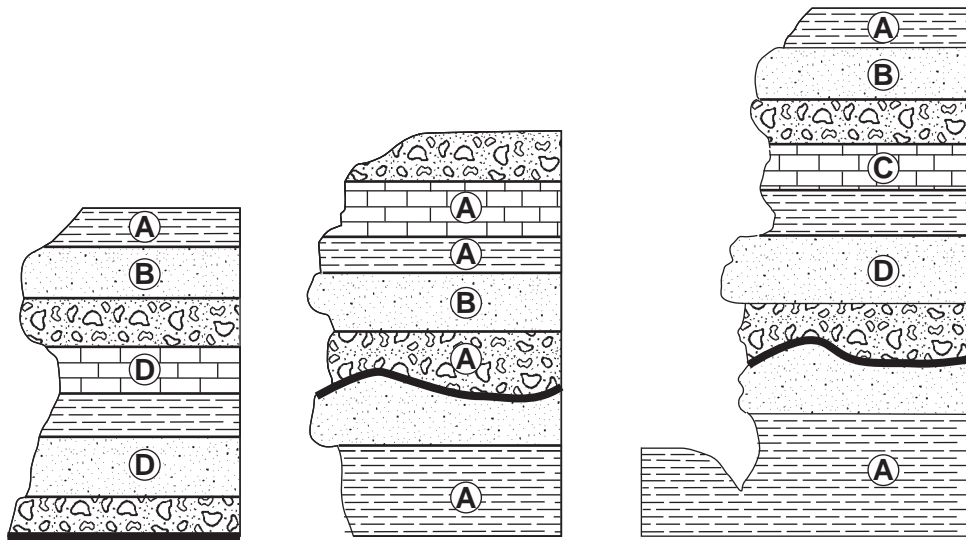

Which fossil appears to have the best characteristics of an index fossil?

- (1) A (2) B (3) C (4) D

- 23 Active volcanoes are most abundant along the

- (1) edges of tectonic plates
 (2) eastern coastline of continents
 (3) 23.5° N and 23.5° S parallels of latitude
 (4) equatorial ocean floor

- 24 Which part of Earth's interior is inferred to have convection currents that cause tectonic plates to move?

- (1) rigid mantle (2) asthenosphere (3) outer core (4) inner core

- 25 Compared to the continental crust, the oceanic crust is

- (1) less dense and less felsic
 (2) less dense and less mafic
 (3) more dense and more felsic
 (4) more dense and more mafic

- 26 The pie graph below shows the elements comprising Earth's crust in percent by mass.

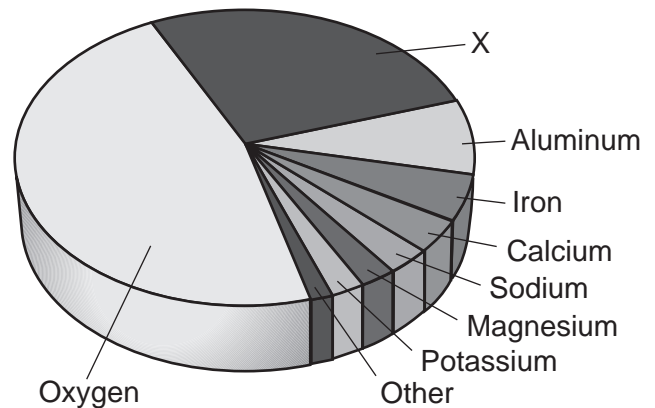

Which element is represented by the letter X?

- (1) silicon (2) lead (3) nitrogen (4) hydrogen

27 The block diagrams below show two landscape regions labeled *A* and *B*.

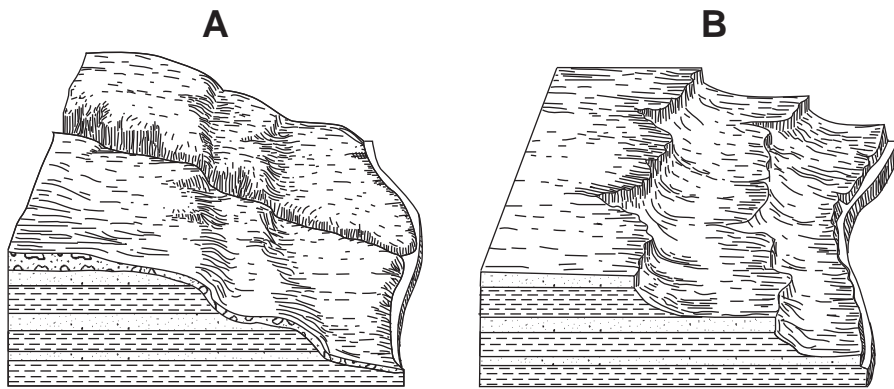

What is the most probable cause of the difference in surface features between *A* and *B*?

- (1) *A* is the result of a humid climate, while *B* is the result of a dry climate.
- (2) *A* is at a high elevation, while *B* is located at sea level.
- (3) *A* is a plateau region, while *B* is a mountainous region.
- (4) *A* is composed of igneous bedrock, while *B* is composed of sedimentary bedrock.

28 The block diagram below shows a region that has undergone faulting.

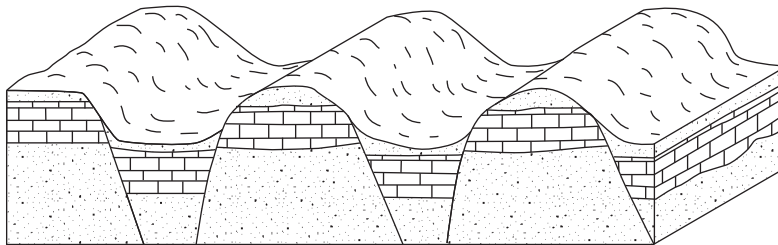

Which map shows the stream drainage pattern that would most likely develop on the surface of this region?

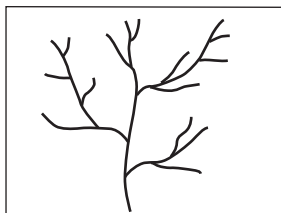

(1)



(2)

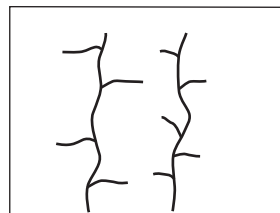

(3)

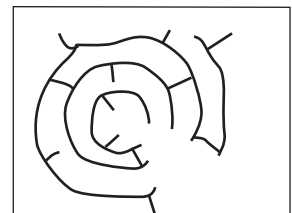

(4)

- 29 The map below shows the bend of a large meandering stream. The arrows show the direction of stream flow. Letters A, B, and C are positions on the streambed where erosion and deposition data were collected.

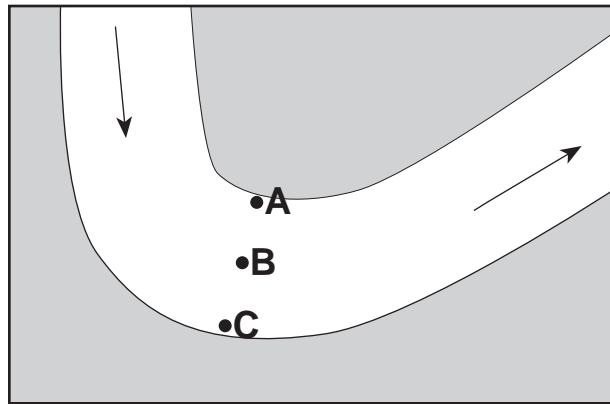

Which table best represents the locations where erosion and deposition are dominant and where an equilibrium exists between the two processes? [A check mark (✓) represents the dominant process for each lettered location.]

	Erosion	Equilibrium	Deposition
A		✓	
B			✓
C	✓		

(1)

	Erosion	Equilibrium	Deposition
A	✓		
B		✓	
C			✓

(3)

	Erosion	Equilibrium	Deposition
A			✓
B	✓		
C		✓	

(2)

	Erosion	Equilibrium	Deposition
A			✓
B		✓	
C	✓		

(4)

- 30 Which graph best represents the relationship between the discharge of a stream and the velocity of stream flow?

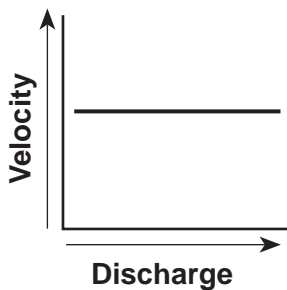

(1)

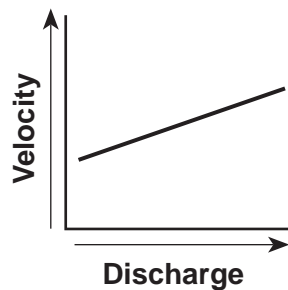

(2)

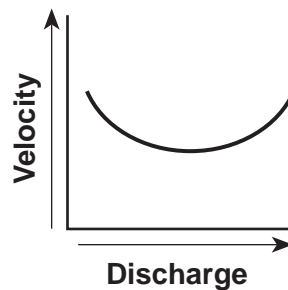

(3)

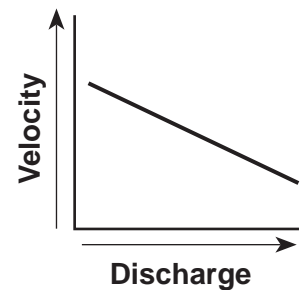

(4)

31 The diagrams below represent four different examples of one process that transports sediments.

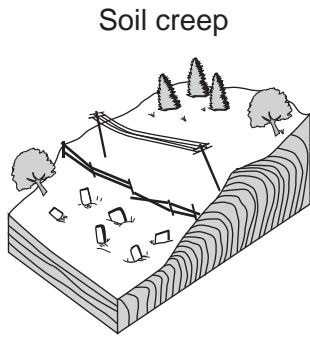

Soil creep
Gradual downhill movement of soil

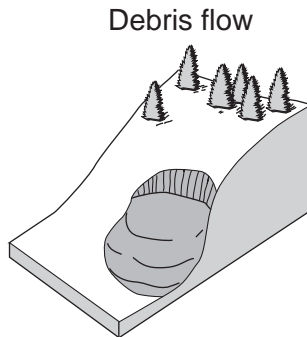

Debris flow
Rapid downslope flow of debris

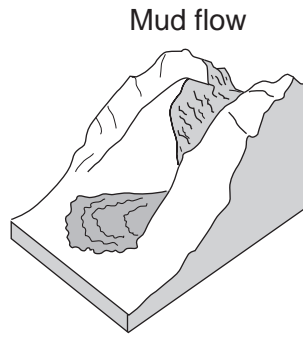

Mud flow
Downward flow of fine particles (mud) and large amounts of water

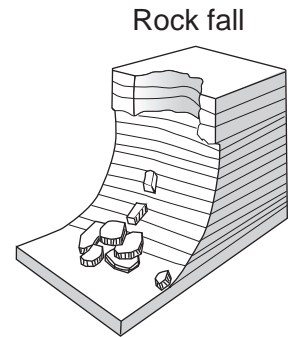

Rock fall
Rapid falling of pieces of rock from a cliff or steep slope

Which process is shown in these diagrams?

- (1) chemical weathering
- (2) wind action
- (3) mass movement
- (4) rock abrasion

32 The cross section below shows a stream flowing downhill. Points A through D are locations in the stream.

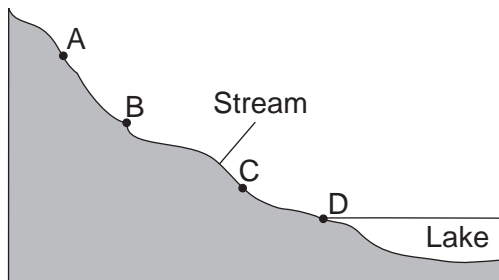

At which point would most deposition occur?

- (1) A
- (2) B
- (3) C
- (4) D

33 A stream flowing at a velocity of 250 centimeters per second is transporting sediment particles ranging in size from clay to cobbles. Which transported particles will be deposited by the stream if its velocity decreases to 100 centimeters per second?

- (1) cobbles, only
- (2) cobbles and some pebbles, only
- (3) cobbles, pebbles, and some sand, only
- (4) cobbles, pebbles, sand, silt, and clay

34 Which rock is sedimentary in origin and formed as a result of chemical processes?

- (1) granite
- (2) shale
- (3) breccia
- (4) dolostone

35 The photograph below shows an igneous rock.



What is the origin and rate of formation of this rock?

- (1) plutonic with slow cooling
- (2) plutonic with rapid cooling
- (3) volcanic with slow cooling
- (4) volcanic with rapid cooling

Part B-1

Answer all questions in this part.

Directions (36–50): For *each* statement or question, write on your separate answer sheet the *number* of the word or expression that, of those given, best completes the statement or answers the question. Some questions may require the use of the *Earth Science Reference Tables*.

Base your answers to questions 36 through 39 on the passage and diagram below. The diagram shows the orbits of the four inner planets and the asteroid Hermes around the Sun. Point A represents a position along Hermes' orbit.

The Curious Tale of Asteroid Hermes

It's dogma [accepted belief] now: an asteroid hit Earth 65 million years ago and wiped out the dinosaurs. But in 1980 when scientists Walter and Luis Alvarez first suggested the idea to a gathering at the American Association for Advancement of Sciences, their listeners were skeptical. Asteroids hitting Earth? Wiping out species? It seemed incredible.

At that very moment, unknown to the audience, an asteroid named Hermes halfway between Mars and Jupiter was beginning a long plunge toward our planet. Six months later it would pass 300,000 miles from Earth's orbit, only a little more than the distance to the Moon....

Hermes approaches Earth's orbit twice every 777 days. Usually our planet is far away when the orbit crossing happens, but in 1937, 1942, 1954, 1974 and 1986, Hermes came harrowingly [dangerously] close to Earth itself. We know about most of these encounters only because Lowell Observatory astronomer Brian Skiff rediscovered Hermes on Oct. 15, 2003.

Astronomers around the world have been tracking it carefully ever since....

Excerpted from "The Curious Tale of Asteroid Hermes," Dr. Tony Phillips, *Science @ NASA*, November 3, 2003

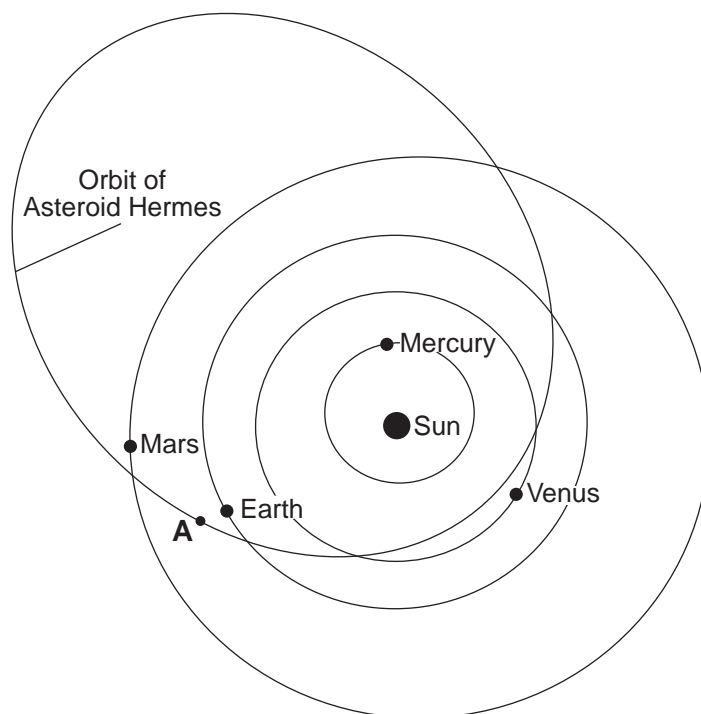

(Not drawn to scale)

36 When Hermes is located at position A and Earth is in the position shown in the diagram, the asteroid can be viewed from Earth at each of the following times *except*

- (1) sunrise
- (2) sunset
- (3) 12 noon
- (4) 12 midnight

37 How does the period of revolution of Hermes compare to the period of revolution of the planets shown in the diagram?

- (1) Hermes has a longer period of revolution than Mercury, but a shorter period of revolution than Venus, Earth, and Mars.
- (2) Hermes has a shorter period of revolution than Mercury, but a longer period of revolution than Venus, Earth, and Mars.
- (3) Hermes has a longer period of revolution than all of the planets shown.
- (4) Hermes has a shorter period of revolution than all of the planets shown.

38 Why is evidence of asteroids striking Earth so difficult to find?

- (1) Asteroids are made mostly of frozen water and gases and are vaporized on impact.
- (2) Asteroids are not large enough to leave impact craters.
- (3) Asteroids do not travel fast enough to create impact craters.
- (4) Weathering, erosion, and deposition on Earth have destroyed or buried most impact craters.

39 According to the diagram, as Hermes and the planets revolve around the Sun, Hermes appears to be a threat to collide with

- (1) Earth, only
- (2) Earth and Mars, only
- (3) Venus, Earth, and Mars, only
- (4) Mercury, Venus, Earth, and Mars

40 The map below shows the location of Grenville-age bedrock found in the northeastern United States.

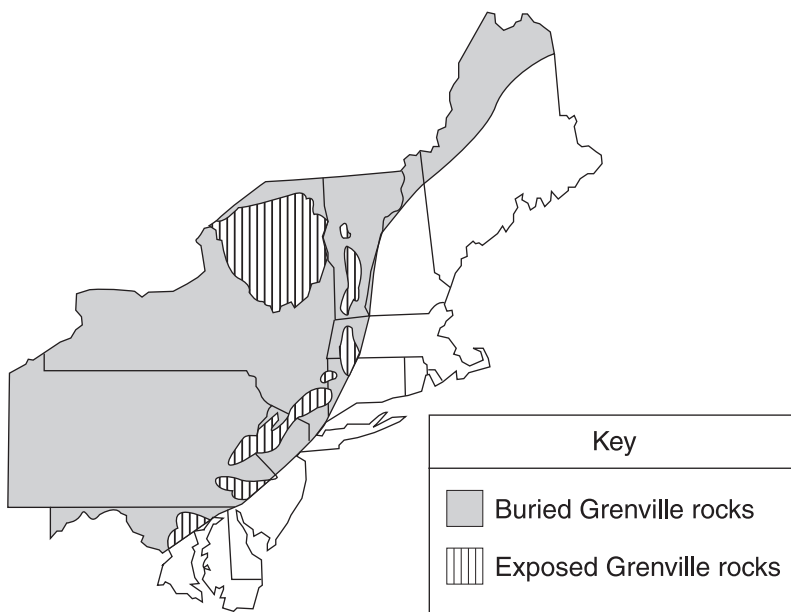

In which New York State landscapes is Grenville-age bedrock exposed at Earth's surface?

- (1) Erie-Ontario Lowlands and St. Lawrence Lowlands
- (2) Catskills and Allegheny Plateau
- (3) Tug Hill Plateau and Atlantic Coastal Plain
- (4) Hudson Highlands and Adirondack Mountains

Base your answers to questions 41 through 44 on the climate graphs below, which show average monthly precipitation and temperatures at four cities, A, B, C, and D.

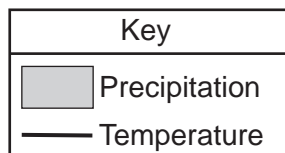
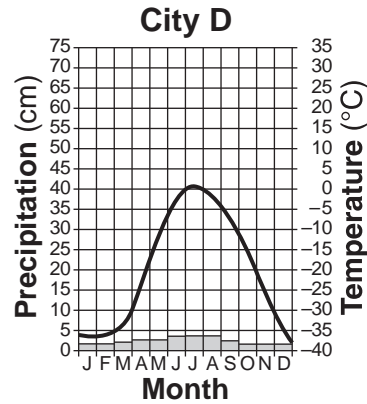
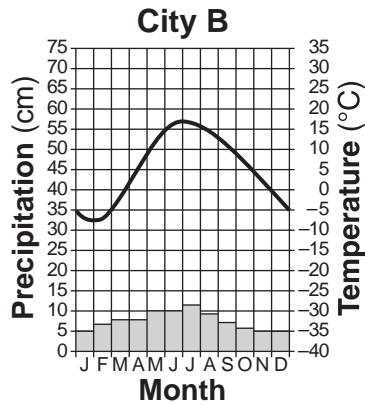
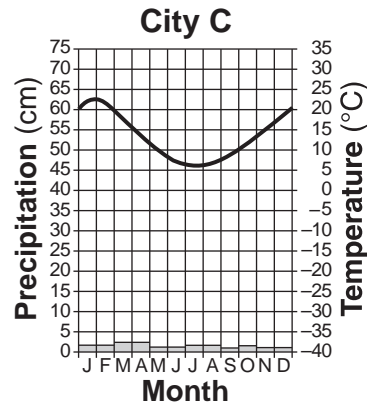
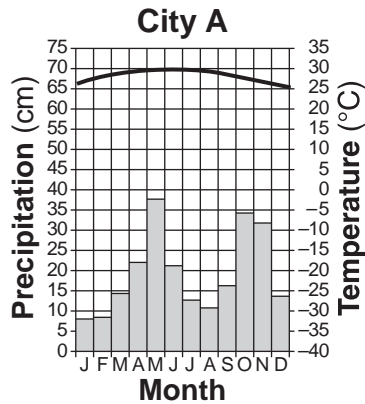

- 41 City A has very little variation in temperature during the year because city A is located
- (1) on the dry side of a mountain
 - (2) on the wet side of a mountain
 - (3) near the center of a large landmass
 - (4) near the equator
- 42 During which season does city B usually experience the month with the highest average precipitation?
- (1) spring
 - (2) summer
 - (3) fall
 - (4) winter

- 43 It can be concluded that city *C* is located in the Southern Hemisphere because city *C* has
- (1) small amounts of precipitation throughout the year
 - (2) large amounts of precipitation throughout the year
 - (3) its warmest temperatures in January and February
 - (4) its warmest temperatures in July and August
- 44 Very little water will infiltrate the soil around city *D* because the region usually has
- (1) a frozen surface
 - (2) nearly flat surfaces
 - (3) a small amount of runoff
 - (4) permeable soil
-

Base your answers to questions 45 through 47 on the block diagram below, which shows a portion of Earth's crust. Letters *A*, *B*, *C*, and *D* indicate sedimentary rock layers.

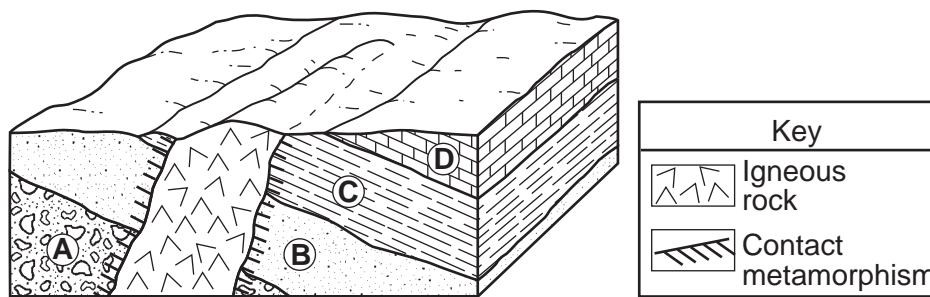

- 45 Which event occurred most recently?
- (1) formation of layer *A*
 - (2) formation of layer *D*
 - (3) tilting of all four sedimentary rock layers
 - (4) erosion of the igneous rock exposed at the surface
- 46 The igneous rock is mostly composed of potassium feldspar and quartz crystals that have an average grain size of 3 millimeters. The igneous rock is most likely
- (1) granite
 - (2) pegmatite
 - (3) gabbro
 - (4) pumice
- 47 Which processes produced rock layer *B*?
- (1) subduction and melting
 - (2) uplift and solidification
 - (3) heat and pressure
 - (4) compaction and cementation
-

Base your answers to questions 48 through 50 on the map of Long Island, New York. *AB*, *CD*, *EF*, and *GH* are reference lines on the map.

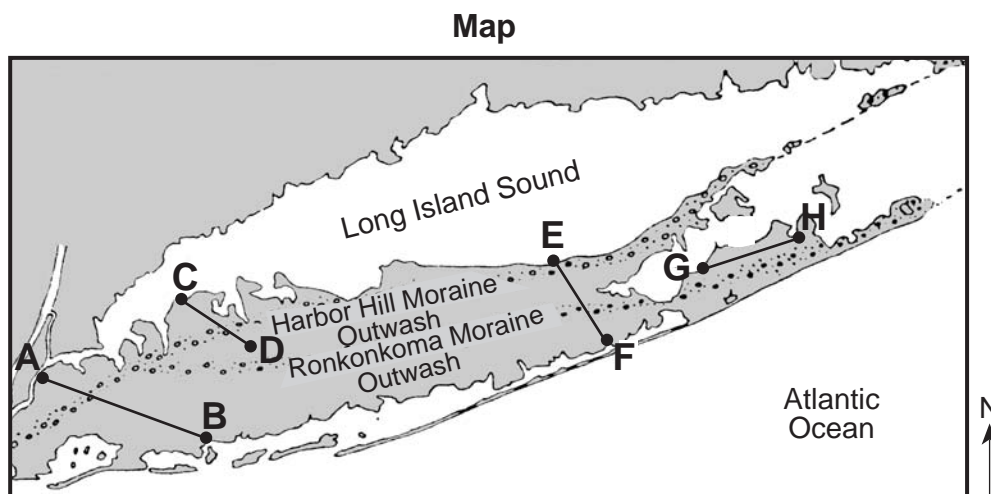

48 Which agent of erosion transported the sediments that formed the moraines shown on the map?

- | | |
|-----------|-------------------|
| (1) water | (3) ice |
| (2) wind | (4) mass movement |

49 The cross section below represents the sediments beneath the land surface along one of the reference lines shown on the map.



Along which reference line was the cross section taken?

- | | |
|---------------|---------------|
| (1) <i>AB</i> | (3) <i>EF</i> |
| (2) <i>CD</i> | (4) <i>GH</i> |

50 A major difference between sediments in the outwash and sediments in the moraines is that the sediments deposited in the outwash are

- | | |
|------------|------------------|
| (1) larger | (3) more angular |
| (2) sorted | (4) older |

Part B–2

Answer all questions in this part.

Directions (51–65): Record your answers in the spaces provided in your answer booklet. Some questions may require the use of the *Earth Science Reference Tables*.

Base your answers to questions 51 through 53 on the cross section in your answer booklet, which shows limestone bedrock with caves.

- 51 In the empty box on the left side of the cross section *in your answer booklet*, draw a horizontal line to indicate the level of the water table. [1]
 - 52 The precipitation in this area is becoming more acidic. Explain why acid rain weathers limestone bedrock. [1]
 - 53 Identify *one* source of pollution caused by human activity that contributes to the precipitation becoming more acidic. [1]
-

Base your answers to questions 54 through 58 on the satellite image shown in your answer booklet. The satellite image shows a low-pressure system over a portion of the United States. Air-mass symbols and frontal boundaries have been added. Line *XY* is one frontal boundary. Points *A*, *B*, *C*, and *D* represent surface locations. White areas represent clouds.

- 54 *In your answer booklet*, draw the proper symbol to represent the most probable front on line *XY*. [1]
 - 55 State *one* process that causes clouds to form in the moist air along the cold front. [1]
 - 56 Describe *one* piece of evidence shown on the map that suggests location *A* has a lower relative humidity than location *B*. [1]
 - 57 Explain why location *C* most likely has a cooler temperature than location *D*. [1]
 - 58 State the compass direction that the center of this low-pressure system will move over the next few days if it follows a normal storm track. [1]
-

Base your answers to questions 59 and 60 on the data table below, which provides information about four of Jupiter's moons.

Data Table

Moons of Jupiter	Density (g/cm³)	Diameter (km)	Distance from Jupiter (km)
Io	3.5	3630	421,600
Europa	3.0	3138	670,900
Ganymede	1.9	5262	1,070,000
Callisto	1.9	4800	1,883,000

59 Identify the planet in our solar system that is closest in diameter to Callisto. [1]

60 In 1610, Galileo was the first person to observe, with the aid of a telescope, these four moons orbiting Jupiter. Explain why Galileo's observation of this motion did *not* support the geocentric model of our solar system. [1]

Base your answers to questions 61 and 62 on the cross section below, which shows a portion of Earth's interior layers and the location of an earthquake epicenter. Letter A represents a seismic station on Earth's surface. Letter B represents a location in Earth's interior.

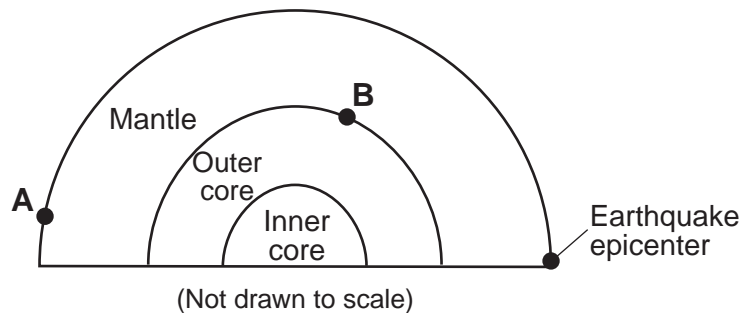

61 Explain why seismic station A receives *P*-waves but *not* *S*-waves from this earthquake. [1]

62 What is the approximate depth at location B? [1]

Base your answers to questions 63 through 65 on the diagram below, which shows Earth's water cycle. Numbers indicate the estimated volume of water, in millions of cubic kilometers, stored at any one time in the atmosphere, the oceans, and on the continents. The yearly amount of water that moves in and out of each of these three portions of Earth is also indicated in millions of cubic kilometers.

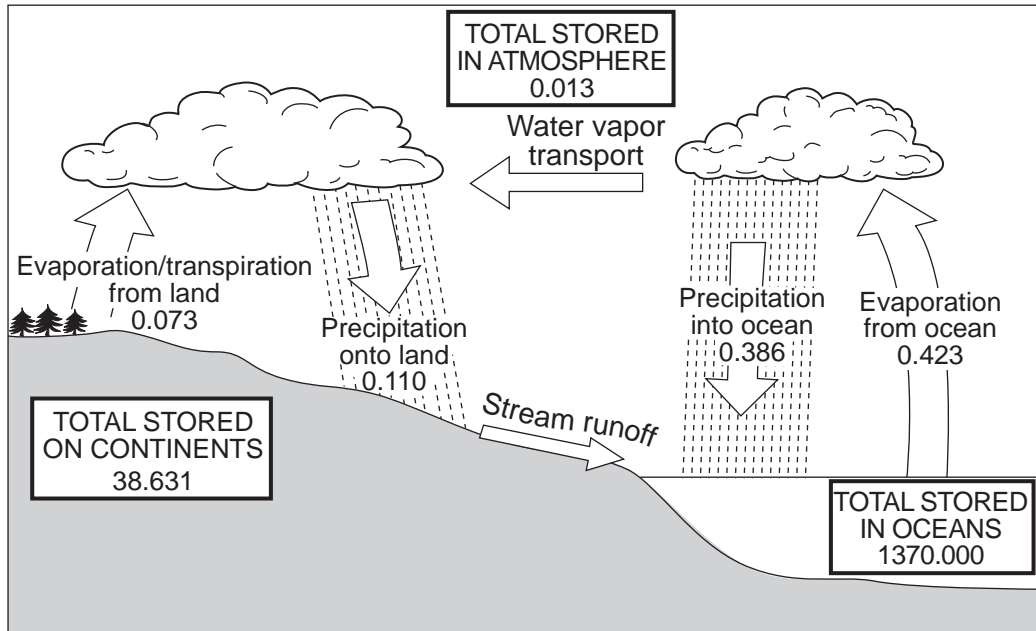

- 63 Calculate the total amount of water stored in the atmosphere, the oceans, and on the continents together at any one time. [1]
- 64 Explain why the yearly total precipitation over the oceans is greater than the yearly total precipitation over the continents. [1]
- 65 Describe *two* surface characteristics that will affect the rate of stream runoff into the ocean. [1]
-

Part C

Answer all questions in this part.

Directions (66–84): Record your answers in the spaces provided in your answer booklet. Some questions may require the use of the *Earth Science Reference Tables*.

Base your answers to questions 66 through 68 on the data table below, which shows the radioactive decay of carbon-14. The number of years required to complete four half-lives has been left blank.

Radioactive Decay of Carbon-14

Number of Half-Lives	Percentage of Original Carbon-14 Remaining	Time (years)
0	100	0
1	50	5700
2	25	11,400
3	12.5	17,100
4	6.3	
5	3.1	28,500
6	1.6	34,200

- 66 On the grid in your answer booklet, construct a graph that shows the radioactive decay of carbon-14 by plotting an **X** to show the percentage of original carbon-14 remaining after *each* half-life. Connect the **X**s with a smooth, curved line. [1]
- 67 How long does it take for radioactive carbon-14 to complete four half-lives? [1]
- 68 The cross section below shows part of Earth's crust. The objects in parentheses indicate materials found within each rock unit or deposit.

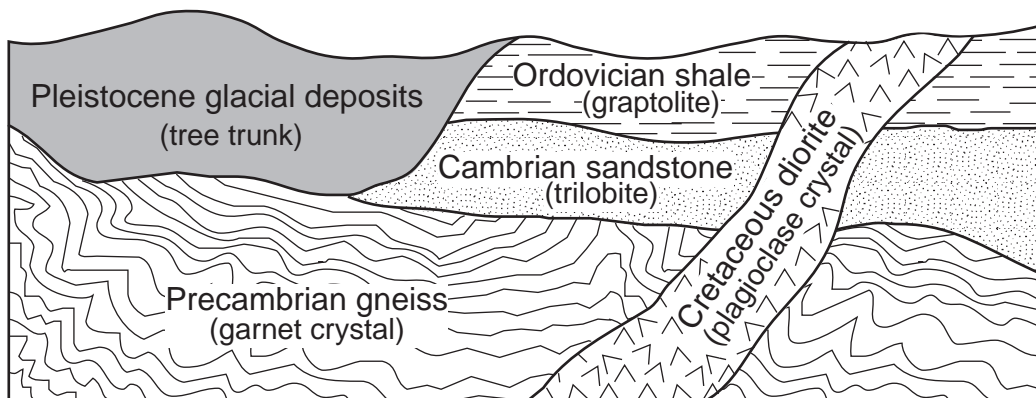

Which object in parentheses could be accurately dated using carbon-14? Explain your answer. [1]

Base your answers to questions 69 through 73 on the passage and cross section below, which explain how some precious gemstones form. The cross section shows a portion of the ancient Tethys Sea, once located between the Indian-Australian Plate and the Eurasian Plate.

Precious Gemstones

Some precious gemstones are a form of the mineral corundum, which has a hardness of 9. Corundum is a rare mineral made up of closely packed aluminum and oxygen atoms, and its formula is Al_2O_3 . If small amounts of chromium replace some of the aluminum atoms in corundum, a bright-red gemstone called a ruby is produced. If traces of titanium and iron replace some aluminum atoms, deep-blue sapphires can be produced.

Most of the world's ruby deposits are found in metamorphic rock that is located along the southern slope of the Himalayas, where plate tectonics played a part in ruby formation. Around 50 million years ago, the Tethys Sea was located between what is now India and Eurasia. Much of the Tethys Sea bottom was composed of limestone that contained the elements needed to make these precious gemstones. The Tethys Sea closed up as the Indian-Australian Plate pushed under the Eurasian Plate, creating the Himalayan Mountains. The limestone rock lining the seafloor underwent metamorphism as it was pushed deep into Earth by the Indian-Australian Plate. For the next 40 to 45 million years, as the Himalayas rose, rubies, sapphires, and other gemstones continued to form.

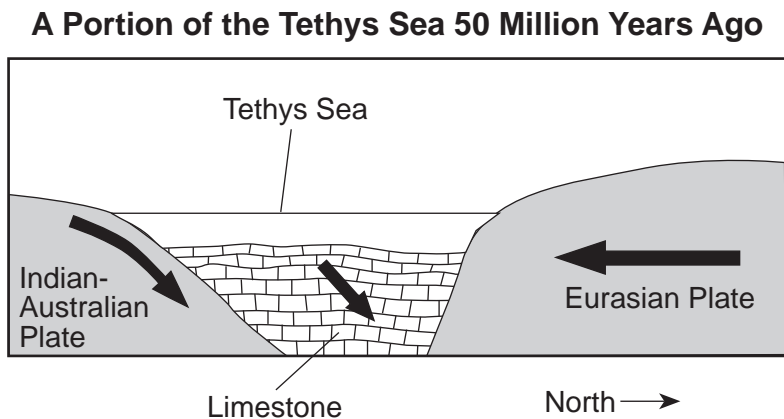

- 69 Which element replaces some of the aluminum atoms, causing the bright-red color of a ruby? [1]
- 70 State *one* physical property of rubies, other than a bright-red color, that makes them useful as gemstones in jewelry. [1]
- 71 Identify the metamorphic rock in which the rubies and sapphires that formed along the Himalayas are usually found. [1]
- 72 During which geologic epoch did the events shown in the cross section of the Tethys Sea occur? [1]
- 73 What type of tectonic plate boundary is shown in the cross section? [1]

Base your answers to questions 74 through 77 on the diagrams below. Diagram 1 shows Earth's location in its orbit on the first day of each of the four seasons, labeled A through D. Diagram 2 shows a north polar view of Earth on March 21. Point E represents a location on Earth's surface. Longitude lines are shown at 15° intervals.

Diagram 1

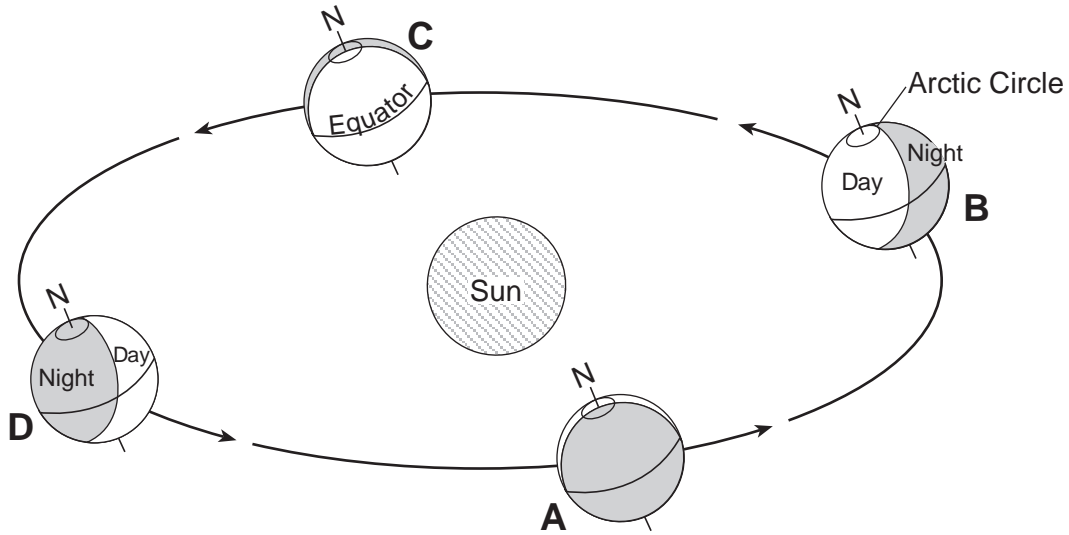

(Not drawn to scale)

Diagram 2

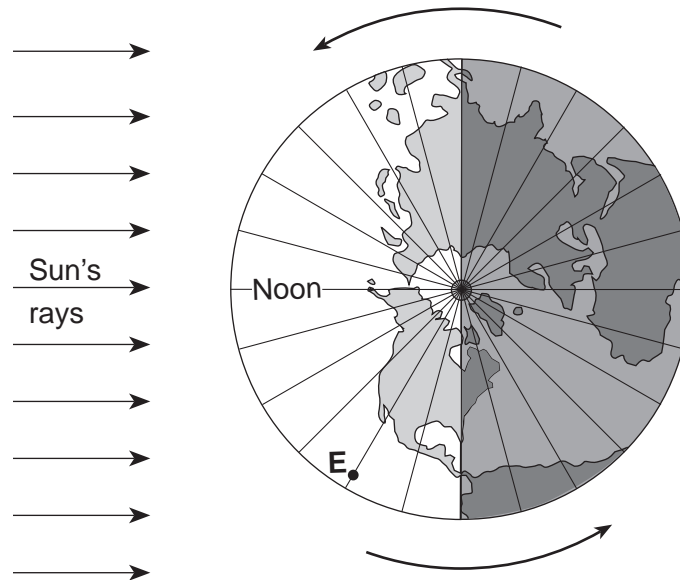

March 21

- 74 How does the altitude of the Sun at solar noon appear to change each day for an observer in New York State as Earth moves from position *A* to position *B* to position *C*? [1]
- 75 Explain why the duration of insolation is 12 hours at both the Arctic Circle and the equator when Earth is at position *C*. [1]
- 76 Describe *one* piece of evidence shown in the diagram which indicates that the Northern Hemisphere is experiencing winter at position *D*. [1]
- 77 State the hour of the day at point *E*. [1]
-

Base your answers to questions 78 through 80 on the map in your answer booklet. The map shows the water depth, measured in feet, at the north end of one of the Finger Lakes. Points *A* and *B* are locations at the lake's shoreline. Points *X* and *Y* are locations on the bottom of the lake.

- 78 On the map *in your answer booklet*, draw the 20-foot-depth isoline. The isoline must extend to the edge of the map. [1]
- 79 On the grid *in your answer booklet*, construct a profile along the line from point *A* to point *B*. Plot the depth along line *AB* by marking an **X** at each numbered point where a water depth is shown. Complete the profile by connecting the **X**s with a smooth, curved line. The **X**s for point *A* and point *B* have been plotted. [2]
- 80 Calculate the gradient between point *X* and point *Y*. Label your answer with the correct units. [1]
-

Base your answers to questions 81 through 84 on the map below, which shows a portion of southwestern United States. On January 17, 1994, an earthquake occurred with an epicenter at Northridge, California.

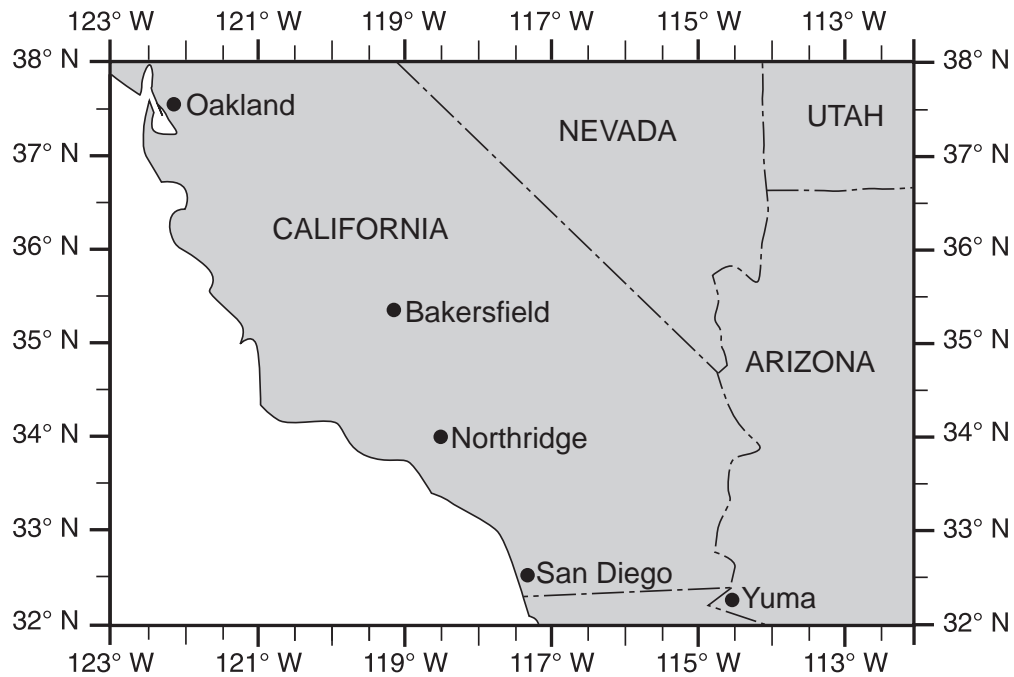

- 81 State the latitude and longitude of Northridge, California. Include the correct units and compass directions in your answer. [1]
- 82 Explain why earthquakes are common in this region of California. [1]
- 83 Of the cities shown on the map, explain why Oakland was the last city to receive *P*-waves from this earthquake. [1]
- 84 List *two* actions that a homeowner could take to prepare the home or family for the next earthquake. [1]
-

Tear Here

The University of the State of New York

REGENTS HIGH SCHOOL EXAMINATION

PHYSICAL SETTING
EARTH SCIENCE

Friday, June 20, 2008 — 1:15 to 4:15 p.m., only

ANSWER SHEET

Student Sex: [] Male [] Female Grade

Teacher School

Record your answers to Part A and Part B-1 on this answer sheet.

Part A

- 1 13 25
2 14 26
3 15 27
4 16 28
5 17 29
6 18 30
7 19 31
8 20 32
9 21 33
10 22 34
11 23 35
12 24

Part A Score

[]

Part B-1

- 36 44
37 45
38 46
39 47
40 48
41 49
42 50
43

Part B-1 Score

[]

Write your answers to Part B-2 and Part C in your answer booklet.

The declaration below must be signed when you have completed the examination.

I do hereby affirm, at the close of this examination, that I had no unlawful knowledge of the questions or answers prior to the examination and that I have neither given nor received assistance in answering any of the questions during the examination.

Signature

Tear Here

Tear Here

Tear Here

PHYSICAL SETTING EARTH SCIENCE

Friday, June 20, 2008 — 1:15 to 4:15 p.m., only

ANSWER BOOKLET

Student..... Sex: Male
 Female
 Teacher
 School..... Grade

Answer all questions in Part B-2 and Part C. Record your answers in this booklet.

<input type="text"/>		
Performance Test Score (Maximum Score: 16)		
.....		
Part	Maximum Score	Student's Score
A	35	
B-1	15	
B-2	15	
C	20	
Total Written Test Score (Maximum Raw Score: 85)		<input type="text"/>
Final Score (from conversion chart)		<input type="text"/>
Raters' Initials:		
Rater 1 Rater 2		

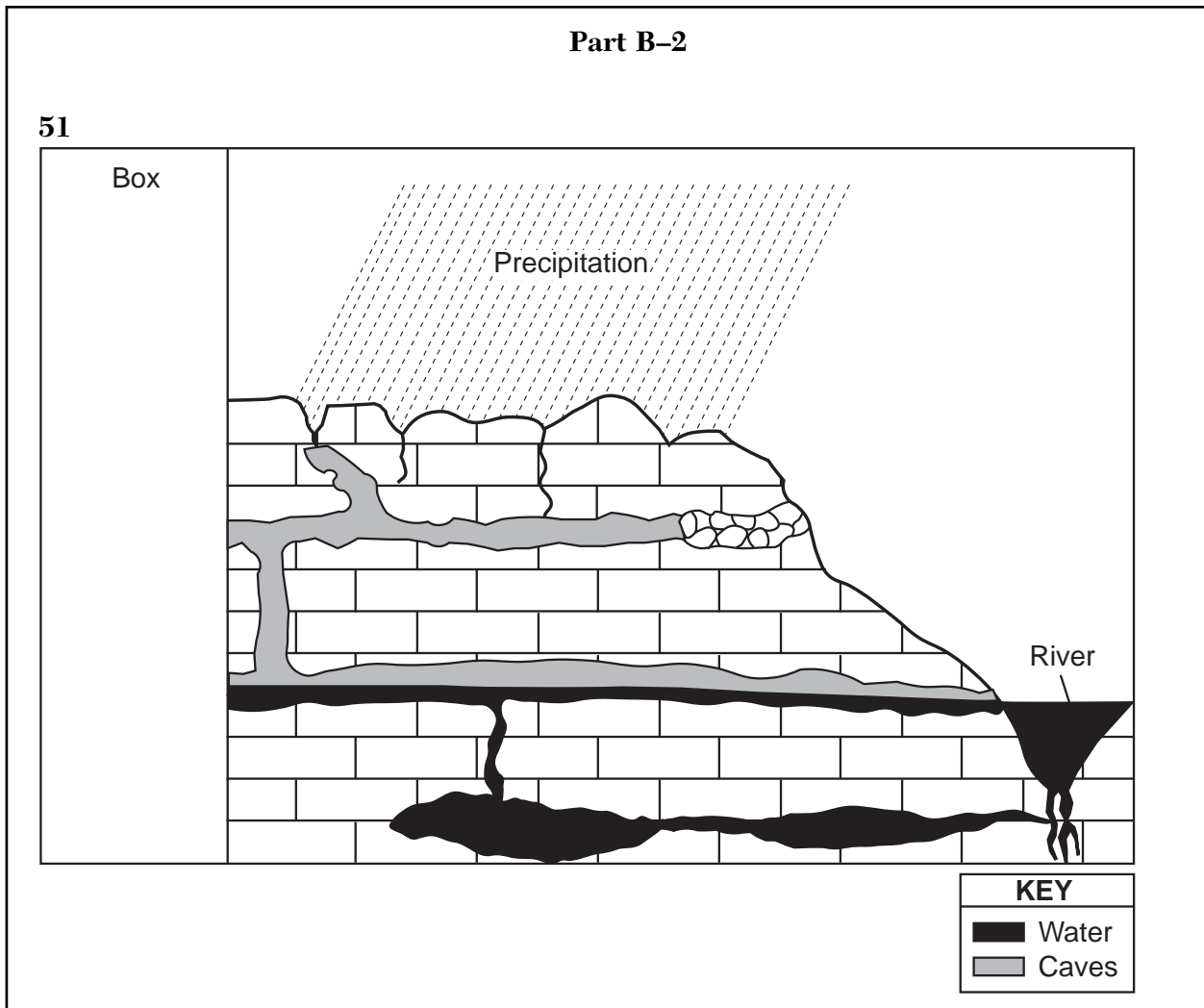

For Raters Only

51

For Raters Only

52

52

53

53

54

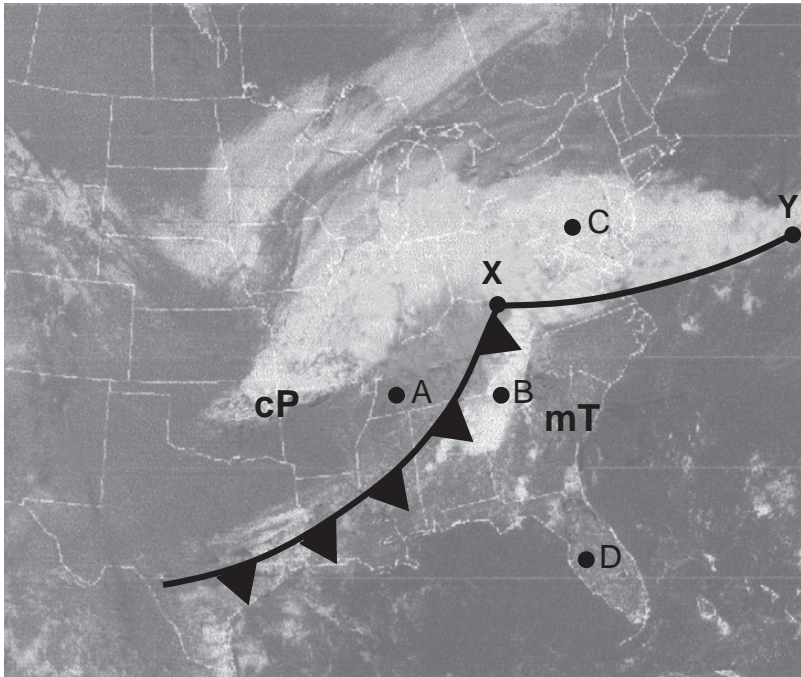

54

55

55

56

56

57

57

58

58

**For Raters
Only**

59 _____

59

60 _____

60

61 _____

61

62 _____ km

62

63 _____ millions of cubic kilometers

63

64 _____

64

65 Characteristic 1: _____

65

Characteristic 2: _____

**Total Score for
Part B-2**

Part C

66

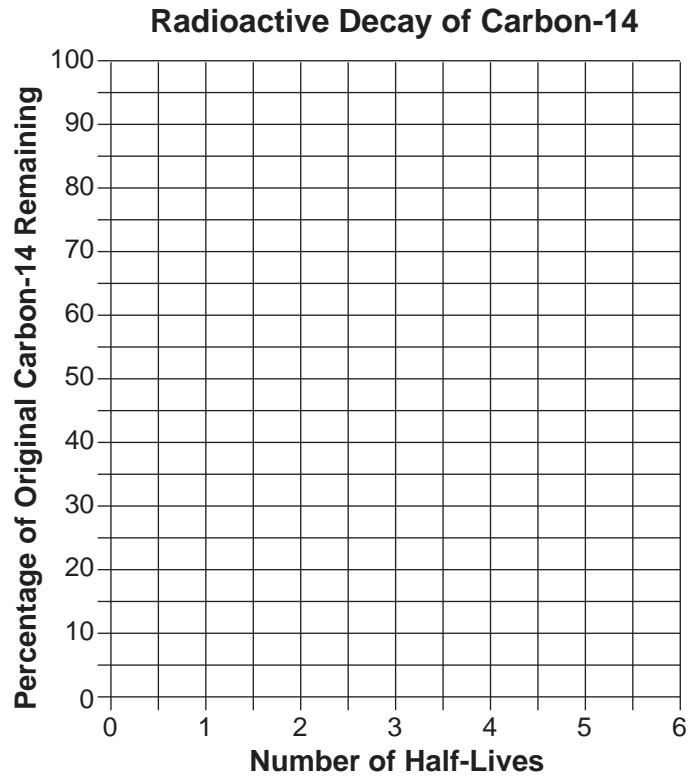

66

67 _____ yr

67

68 Object: _____

Explanation: _____

68

69 _____

69

70 _____

70

71 _____

71

72 _____ Epoch

72

73 _____

73

**For Raters
Only**

74 _____

74

75 _____

75

76 _____

76

77 _____

77

For
Raters
Only

78

Water Depths (feet)

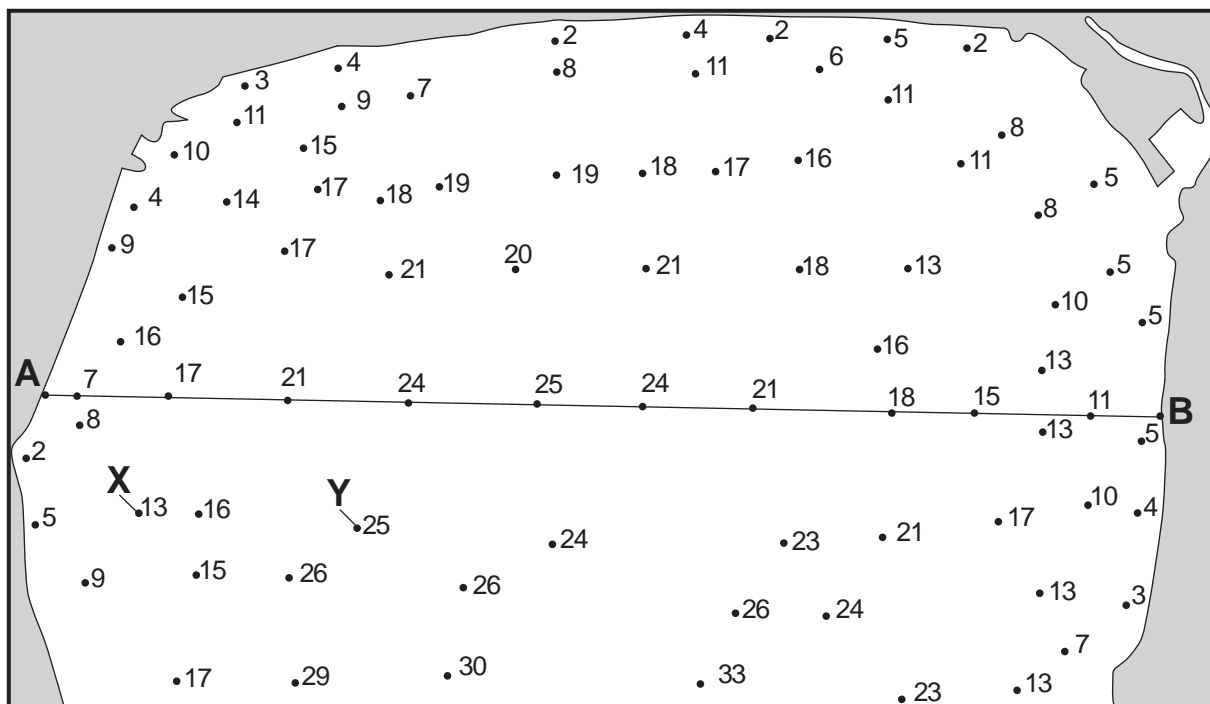

78

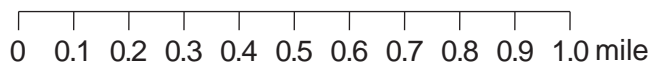

79

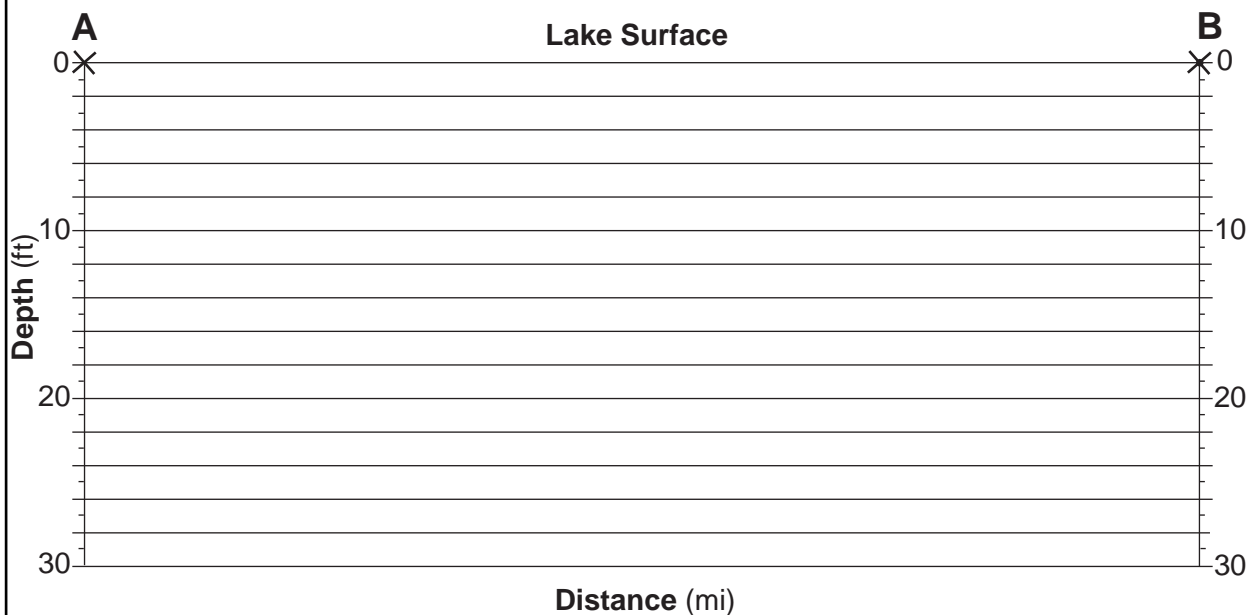

79



**For Raters
Only**

80 Gradient: _____

80

81 Latitude: _____

81

Longitude: _____

82 _____

82

83 _____

83

84 Action 1: _____

84

Action 2: _____

**Total Score
for Part C**

FOR TEACHERS ONLY

The University of the State of New York
REGENTS HIGH SCHOOL EXAMINATION

PS-ES PHYSICAL SETTING/EARTH SCIENCE

Friday, June 20, 2008 — 1:15 to 4:15 p.m., only

SCORING KEY AND RATING GUIDE

Directions to the Teacher:

Refer to the directions on page 3 before rating student papers.

Updated information regarding the rating of this examination may be posted on the New York State Education Department's web site during the rating period. Check this web site <http://www.emsc.nysed.gov/osa/> and select the link "Examination Scoring Information" for any recently posted information regarding this examination. This site should be checked before the rating process for this examination begins and several times throughout the Regents examination period.

Part A and Part B-1

Allow 1 credit for each correct response.

Part A			Part B-1	
1 2	13 1	25 4	36 3	44 1
2 1	14 2	26 1	37 3	45 4
3 4	15 3	27 1	38 4	46 1
4 2	16 2	28 3	39 3	47 4
5 1	17 4	29 4	40 4	48 3
6 2	18 3	30 2	41 4	49 3
7 4	19 4	31 3	42 2	50 2
8 3	20 3	32 4	43 3	
9 3	21 3	33 2		
10 1	22 2	34 4		
11 2	23 1	35 4		
12 2	24 2			

Directions to the Teacher

Follow the procedures below for scoring student answer papers for the Physical Setting/Earth Science examination. Additional information about scoring is provided in the publication *Information Booklet for Scoring Regents Examinations in the Sciences*.

Use only *red* ink or *red* pencil in rating Regents papers. Do *not* correct the student's work by making insertions or changes of any kind.

On the detachable answer sheet for Part A and Part B–1, indicate by means of a check mark each incorrect or omitted answer. In the box provided at the end of each part, record the number of questions the student answered correctly for that part.

At least two science teachers must participate in the scoring of each student's responses to the Part B–2 and Part C open-ended questions. Each of these teachers should be responsible for scoring a selected number of the open-ended questions on each answer paper. No one teacher is to score all the open-ended questions on a student's answer paper.

Students' responses must be scored strictly according to the Scoring Key and Rating Guide. For open-ended questions, credit may be allowed for responses other than those given in the rating guide if the response is a scientifically accurate answer to the question and demonstrates adequate knowledge as indicated by the examples in the rating guide. In the student's answer booklet, record the number of credits earned for each answer in the box printed to the right of the answer lines or spaces for that question.

Fractional credit is *not* allowed. Only whole-number credit may be given to a response. Units need not be given when the wording of the questions allows such omissions.

Raters should enter the scores earned for Part A, Part B–1, Part B–2, and Part C on the appropriate lines in the box printed on the answer booklet and then should add these four scores and enter the total in the box labeled "Total Written Test Score." The student's score for the Earth Science Performance Test should be entered in the space provided. Then, the student's raw scores on the performance test and written test should be converted to a scaled score by using the conversion chart that will be posted on the Department's web site <http://www.emsc.nysed.gov/osa/> on Friday, June 20, 2008. The student's scaled score should be entered in the labeled box on the student's answer booklet. The scaled score is the student's final examination score.

All student answer papers that receive a scaled score of 60 through 64 **must** be scored a second time. For the second scoring, a different committee of teachers may score the student's paper or the original committee may score the paper, except that no teacher may score the same open-ended questions that he/she scored in the first rating of the paper. The school principal is responsible for assuring that the student's final examination score is based on a fair, accurate, and reliable scoring of the student's answer paper.

Because scaled scores corresponding to raw scores in the conversion chart may change from one examination to another, it is crucial that for each administration, the conversion chart provided for that administration be used to determine the student's final score.

Part B–2

Allow a total of 15 credits for this part. The student must answer all questions in this part.

51 [1] Allow 1 credit. The student’s line must be at the same level as the black line shown below.

Example of a 1-credit response:

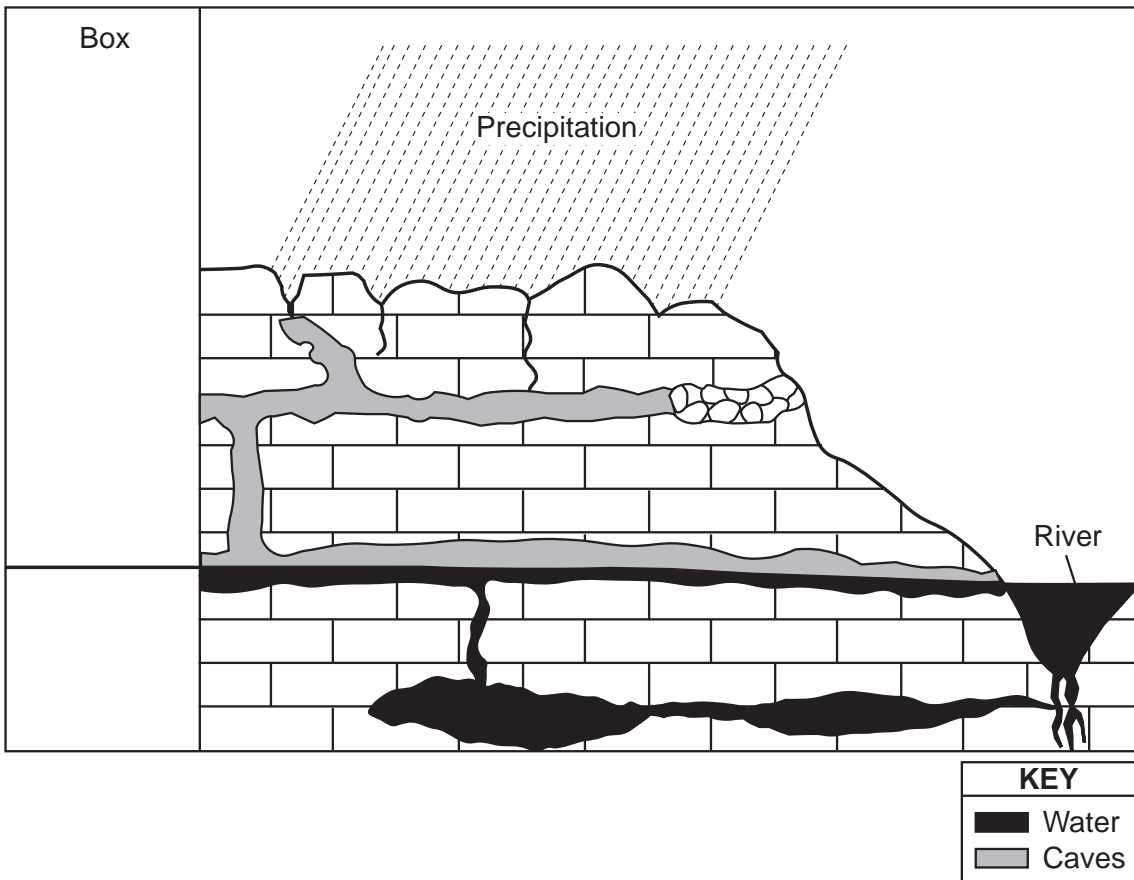

52 [1] Allow 1 credit. Acceptable responses include, but are not limited to:

- The acid rain dissolves the limestone.
- The calcite in limestone chemically reacts with the acid.

53 [1] Allow 1 credit. Acceptable responses include, but are not limited to:

- burning fossil fuels
- exhaust emission from automobiles
- smoke from factories

54 [1] Allow 1 credit for the warm-front symbol drawn on the correct side of line XY.

Example of a 1-credit response:

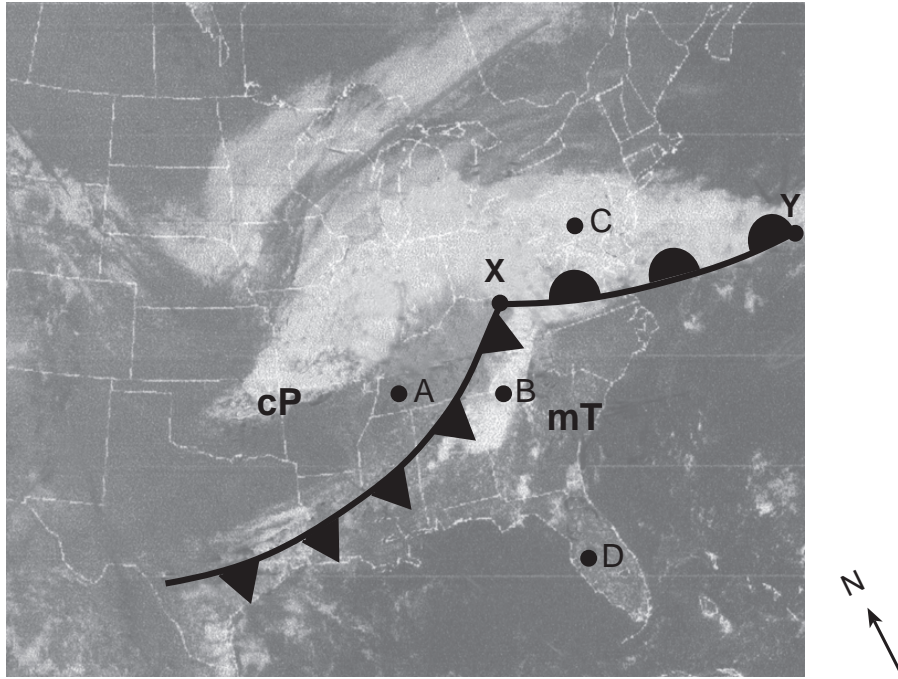

55 [1] Allow 1 credit. Acceptable responses include, but are not limited to:

- condensation
- expanding air
- cooling to the dewpoint
- rising air
- deposition (sublimation)

56 [1] Allow 1 credit. Acceptable responses include, but are not limited to:

- Location A is influenced by a cold, dry air mass.
- Location A has clear skies.
- Location B is in a warm, moist air mass.
- Location B has cloud cover.

57 [1] Allow 1 credit. Acceptable responses include, but are not limited to:

- Location C is cooler because it is farther north.
- C is in a continental polar air mass, which is cold, dry air.
- Location C has clouds that block some of the sunlight.

- 58** [1] Allow 1 credit. Acceptable responses include, but are not limited to:
- east
 - northeast
 - ENE
- 59** [1] Allow 1 credit for Mercury.
- 60** [1] Allow 1 credit. Acceptable responses include, but are not limited to:
- These moons orbit Jupiter, not Earth.
 - The geocentric model has all celestial objects revolving around Earth.
- 61** [1] Allow 1 credit. Acceptable responses include, but are not limited to:
- *P*-waves can travel through the liquid outer core, but *S*-waves cannot.
 - *P*-waves travel through all parts of Earth’s interior.
 - *S*-waves do not pass through the outer core.
- 62** [1] Allow 1 credit for any value from 2800 to 3000 km.
- 63** [1] Allow 1 credit for any value from 1408 to 1409 millions of cubic kilometers.
- 64** [1] Allow 1 credit. Acceptable responses include, but are not limited to:
- The oceans cover a larger portion of Earth’s surface than the continents.
 - Air over oceans has more moisture than air over land.
 - More evaporation occurs over the oceans.
- 65** [1] Allow 1 credit for *two* acceptable characteristics. Acceptable responses include, but are not limited to:
- slope of the land surface
 - soil type or composition
 - vegetation or lack of vegetation
 - land use/a paved surface
 - degree of soil saturation
 - porosity of the soil
 - permeability or impermeability of the surface

Part C

Allow a total of 20 credits for this part. The student must answer all questions in this part.

- 66** [1] Allow 1 credit if the centers of all **Xs** are correctly plotted within the circles shown below and the **Xs** are correctly connected with a line that falls within the circles.

Example of a 1-credit graph:

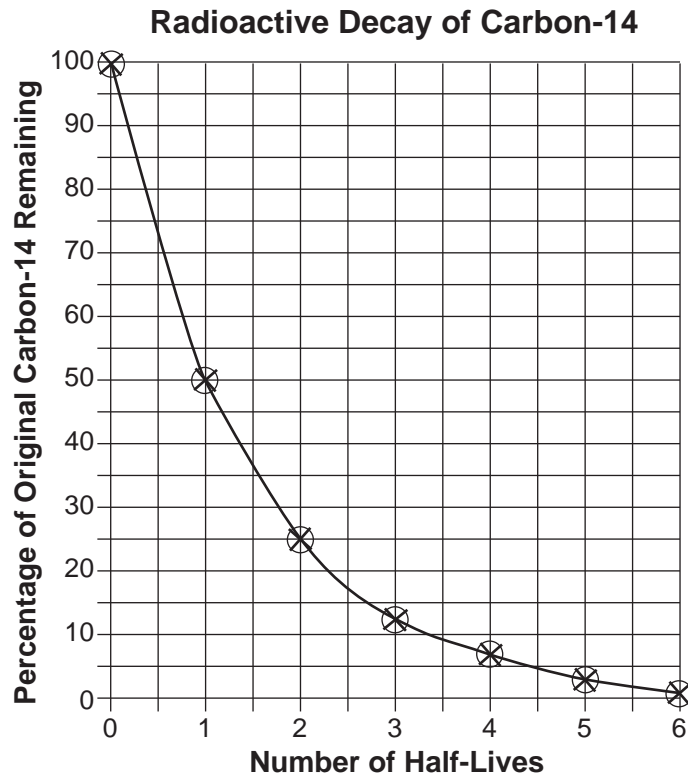

Note: It is recommended that an overlay be used to ensure uniformity in scoring.

- 67** [1] Allow 1 credit for 22,800 yr.
- 68** [1] Allow 1 credit for tree trunk and an acceptable explanation. Acceptable explanations include, but are not limited to:
- The tree trunk is a recent organic remain.
 - Carbon-14 is used to date recent remains.

- 69** [1] Allow 1 credit for chromium *or* Cr.
- 70** [1] Allow 1 credit. Acceptable responses include, but are not limited to:
- hardness
 - luster
 - crystal shape
- 71** [1] Allow 1 credit for marble.
- 72** [1] Allow 1 credit for Eocene Epoch.
- 73** [1] Allow 1 credit. Acceptable responses include, but are not limited to:
- convergent plate boundary
 - subduction zone
 - collision boundary
- 74** [1] Allow 1 credit. Acceptable responses include, but are not limited to:
- The Sun will appear higher in the sky as Earth moves to position *B*, then lower in the sky as it moves to position *C*.
 - The angle increases as it approaches *B*, and decreases as it approaches *C*.
 - The altitude will increase, then decrease.
- 75** [1] Allow 1 credit. Acceptable responses include, but are not limited to:
- On an equinox, all locations will have the same duration of insolation.
 - The Sun’s direct rays are at the equator on this day.
 - Each location is in sunlight for half of the 24-hour Earth rotation.
- 76** [1] Allow 1 credit. Acceptable responses include, but are not limited to:
- Earth’s Northern Hemisphere is tilted away from the Sun.
 - The Arctic Circle is dark and has 24 hours of night.
 - Less sunlight is received in the Northern Hemisphere.
- 77** [1] Allow 1 credit for 4 p.m. *or* 1600 hours. Do *not* allow credit for 4 or 4 a.m.

- 78 [1] Allow 1 credit for correctly drawing the 20-foot-depth isoline. It must extend to the edge of the map to receive credit. If other isolines are drawn, all lines must be correct to receive credit.

Example of a 1-credit response:

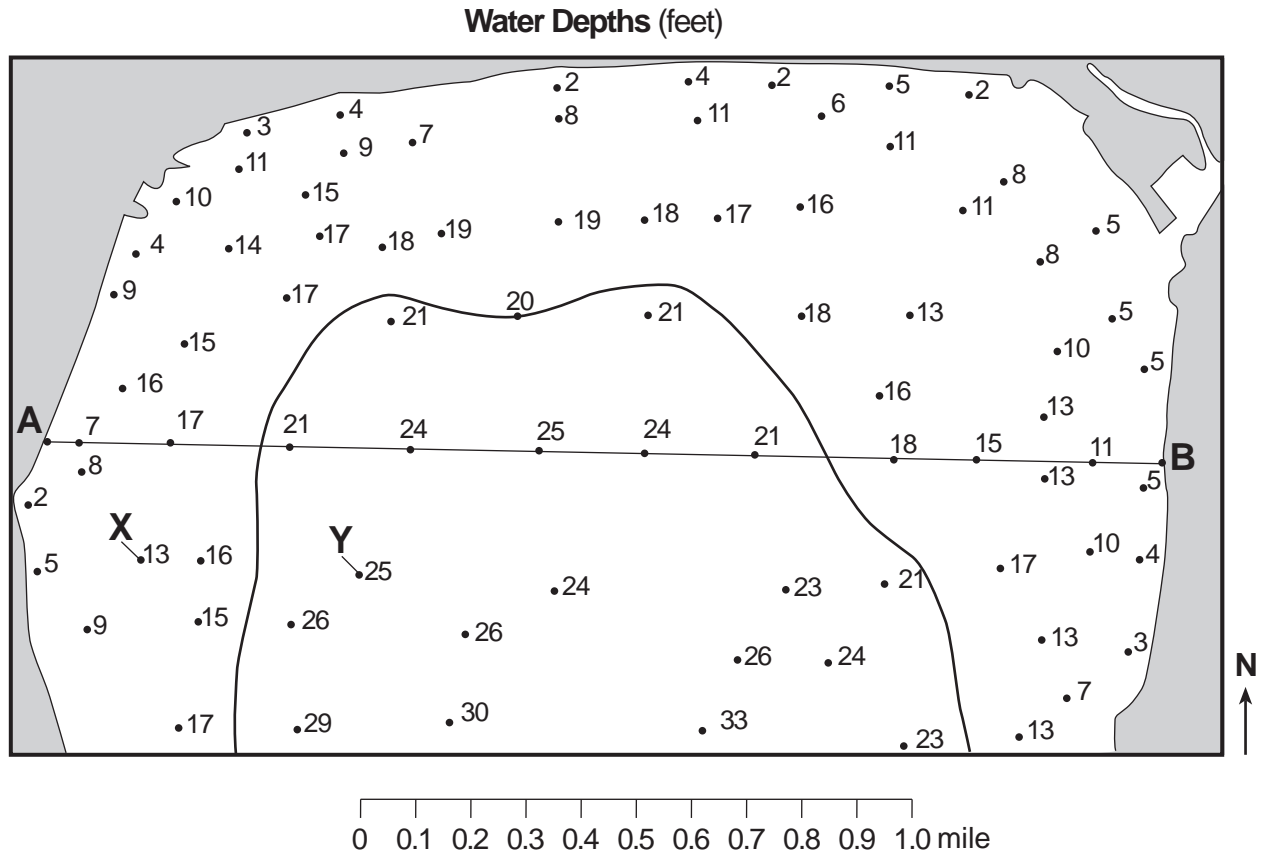

79 [2] Allow a maximum of 2 credits, allocated as follows:

Allow 2 credits if the centers of all ten student-plotted **X**s are within the circles shown below and the **X**s are correctly connected with a line that falls within the circles.

Allow 1 credit if the centers of only eight or nine student-plotted **X**s are within the circles shown below and the **X**s are correctly connected with a line that falls within the circles.

or

Allow 1 credit if all ten student-plotted **X**s are within the circles shown below, but *not* correctly connected with a line.

Example of a 2-credit response:

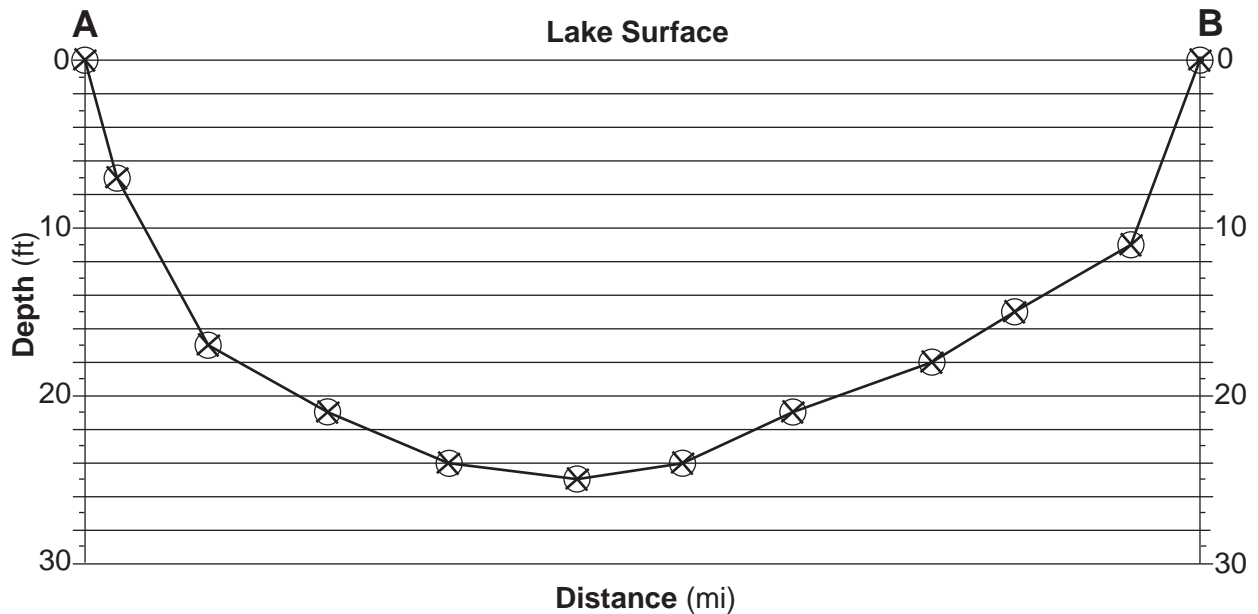

80 [1] Allow 1 credit for any value from 28 to 32 with correct units. Acceptable units include, but are not limited to:

- feet/mile
- ft/mi
- feet per mile

- 81** [1] Allow 1 credit if all values, units, and compass directions for latitude and longitude are correct, as shown.

Latitude: 34° N

Longitude: 118.5° W

118° 30' W

- 82** [1] Allow 1 credit. Acceptable responses include, but are not limited to:

- It is near a plate boundary.
- The San Andreas Fault is nearby.
- The bedrock contains many faults.

- 83** [1] Allow 1 credit. Acceptable responses include, but are not limited to:

- Oakland is farthest from the epicenter.

- 84** [1] Allow 1 credit for *two* acceptable responses. Acceptable responses include, but are not limited to:

- secure heavy objects
- prepare an emergency medical kit
- plan an evacuation route
- locate the nearest shelter
- reinforce house structure

Regents Examination in Physical Setting/Earth Science

June 2008

Chart for Converting Total Test Raw Scores to Final Examination Scores (Scaled Scores)

The *Chart for Determining the Final Examination Score for the June 2008 Regents Examination in Physical Setting/Earth Science* will be posted on the Department's web site <http://www.emsc.nysed.gov/osa/> on Friday, June 20, 2008. Conversion charts provided for previous administrations of the Regents Examination in Physical Setting/Earth Science must NOT be used to determine students' final scores for this administration.

Submitting Teacher Evaluations of the Test to the Department

Suggestions and feedback from teachers provide an important contribution to the test development process. The Department provides an online evaluation form for State assessments. It contains spaces for teachers to respond to several specific questions and to make suggestions. Instructions for completing the evaluation form are as follows:

1. Go to www.emsc.nysed.gov/osa/exameval.
2. Select the test title.
3. Complete the required demographic fields.
4. Complete each evaluation question and provide comments in the space provided.
5. Click the SUBMIT button at the bottom of the page to submit the completed form.

Map to Core Curriculum

June 2008 Physical Setting/Earth Science			
Question Numbers			
Key Ideas/Performance Indicators	Part A	Part B	Part C
Standard 1			
Math Key Idea 1		63	66, 79, 80
Math Key Idea 2	26, 30, 33	37, 38, 41, 42, 43	
Math Key Idea 3		59	67
Science Inquiry Key Idea 1	1, 4, 14	36, 39, 44, 45, 50, 52, 60, 64	68, 69, 82
Science Inquiry Key Idea 2			
Science Inquiry Key Idea 3	6	37, 38, 46, 47, 59	71, 72
Engineering Design Key Idea 1			
Standard 2			
Key Idea 1			
Key Idea 2			
Key Idea 3			
Standard 6			
Key Idea 1		65	69, 70
Key Idea 2	10, 11, 12, 13, 14, 15, 16, 17, 20, 21, 22, 26, 27, 28, 29, 31, 32, 35	36, 40, 45, 48, 49, 51, 54, 55, 56, 57, 58, 61, 62, 63	71, 73, 74, 75, 76, 77, 78, 79, 81, 82, 83
Key Idea 3	2		80, 81
Key Idea 4			
Key Idea 5	12	55, 56, 57, 58	67, 80
Key Idea 6			
Standard 7			
Key Idea 1		53	
Key Idea 2			84
Standard 4			
Key Idea 1	1, 2, 3, 4, 5, 10, 11, 12, 13, 15, 20, 21, 22	36, 37, 38, 39, 44, 45, 51, 59, 60, 63, 64, 65	66, 67, 68, 72, 77, 81
Key Idea 2	6, 7, 8, 9, 14, 16, 17, 18, 19, 23, 24, 25, 27, 28, 29, 30, 31, 32, 33	39, 40, 41, 42, 43, 48, 49, 50, 52, 53, 54, 55, 56, 57, 58, 61, 62	73, 74, 75, 76, 78, 79, 80, 82, 83, 84
Key Idea 3	26, 34, 35	46, 47	69, 70, 71
Reference Tables			
ESRT 2001 Edition (Revised)	2, 3, 6, 14, 16, 18, 20, 21, 23, 24, 25, 26, 33, 34, 35	37, 38, 46, 47, 54, 59, 62	67, 71, 72, 73, 80, 82

Regents Examination in Physical Setting/Earth Science – June 2008

Chart for Converting Total Test Raw Scores to Final Examination Scores (Scaled Scores)

To determine the student's final score, locate the student's Total Performance Test Score across the top of the chart and the Total Written Test Score down the side of the chart. The point where the two scores intersect is the student's final examination score. For example, a student receiving a Total Performance Test Score of 10 and Total Written Test Score of 72 would receive a final examination score of 90.

		Total Performance Test Score																
		16	15	14	13	12	11	10	9	8	7	6	5	4	3	2	1	0
Total Written Test Score	85	100	99	99	99	98	98	97	96	96	95	94	93	91	90	88	87	85
	84	99	99	98	98	98	97	96	96	95	94	93	92	91	89	88	86	84
	83	99	99	98	98	98	97	96	96	95	94	93	92	91	89	88	86	84
	82	98	98	98	97	97	96	95	95	94	93	92	91	90	88	87	85	83
	81	97	97	97	96	96	95	95	94	93	92	91	90	89	88	86	84	82
	80	97	97	97	96	96	95	95	94	93	92	91	90	89	88	86	84	82
	79	97	96	96	95	95	94	94	93	92	91	90	89	88	87	85	83	82
	78	96	95	95	95	94	94	93	92	91	91	89	88	87	86	84	83	81
	77	96	95	95	95	94	94	93	92	91	91	89	88	87	86	84	83	81
	76	95	95	94	94	93	93	92	91	91	90	89	88	86	85	83	82	80
	75	94	94	93	93	92	92	91	90	90	89	88	87	86	84	83	81	79
	74	94	94	93	93	92	92	91	90	90	89	88	87	86	84	83	81	79
	73	93	93	92	92	92	91	90	90	89	88	87	86	85	83	82	80	78
	72	92	92	92	91	91	90	90	89	88	87	86	85	84	82	81	79	77
	71	92	91	91	90	90	89	89	88	87	86	85	84	83	82	80	78	77
	70	91	90	90	89	89	88	88	87	86	85	84	83	82	81	79	77	76
	69	91	90	90	89	89	88	88	87	86	85	84	83	82	81	79	77	76
	68	90	90	89	89	88	88	87	86	85	85	84	82	81	80	78	77	75
	67	89	89	88	88	87	87	86	85	85	84	83	82	80	79	77	76	74
	66	88	88	87	87	86	86	85	85	84	83	82	81	80	78	77	75	73
	65	87	87	87	86	86	85	84	84	83	82	81	80	79	77	76	74	72
64	86	86	86	85	85	84	84	83	82	81	80	79	78	77	75	73	71	
63	86	85	85	84	84	83	83	82	81	80	79	78	77	76	74	72	71	
62	86	85	85	84	84	83	83	82	81	80	79	78	77	76	74	72	71	
61	85	84	84	84	83	82	82	81	80	79	78	77	76	75	73	72	70	
60	84	84	83	83	82	82	81	80	80	79	78	77	75	74	72	71	69	
59	83	83	82	82	81	81	80	79	79	78	77	76	74	73	71	70	68	
58	82	82	81	81	81	80	79	79	78	77	76	75	74	72	71	69	67	
57	81	81	81	80	80	79	78	78	77	76	75	74	73	71	70	68	66	
56	80	80	80	79	79	78	78	77	76	75	74	73	72	71	69	67	65	
55	80	79	79	78	78	77	77	76	75	74	73	72	71	70	68	66	65	
54	79	78	78	78	77	77	76	75	74	74	72	71	70	69	67	66	64	
53	78	78	77	77	76	76	75	74	74	73	72	71	69	68	66	65	63	
52	77	77	76	76	75	75	74	73	73	72	71	70	69	67	66	64	62	
51	76	76	75	75	75	74	73	73	72	71	70	69	68	66	65	63	61	
50	75	75	75	74	74	73	73	72	71	70	69	68	67	65	64	62	60	
49	75	74	74	73	73	72	72	71	70	69	68	67	66	65	63	61	60	
48	73	73	72	72	71	71	70	69	68	68	67	66	65	63	61	60	58	
47	72	72	71	71	70	70	69	68	68	67	66	65	63	62	60	59	57	
46	71	71	70	70	69	69	68	68	67	66	65	64	63	61	60	58	56	
45	70	70	70	69	69	68	67	67	66	65	64	63	62	60	59	57	55	
44	69	69	69	68	68	67	67	66	65	64	63	62	61	60	58	56	54	

Total Performance Test Score
June 2008 Examination in Physical Setting/Earth Science – continued

		Total Performance Test Score																
		16	15	14	13	12	11	10	9	8	7	6	5	4	3	2	1	0
Total Written Test Score	43	69	68	68	67	67	66	66	65	64	63	62	61	60	59	57	55	54
	42	68	67	67	67	66	65	65	64	63	62	61	60	59	58	56	55	53
	41	66	66	65	65	64	64	63	62	62	61	60	59	57	56	54	53	51
	40	65	65	64	64	64	63	62	62	61	60	59	58	57	55	54	52	50
	39	64	64	64	63	63	62	61	61	60	59	58	57	56	54	53	51	49
	38	63	63	63	62	62	61	61	60	59	58	57	56	55	54	52	50	48
	37	63	62	62	61	61	60	60	59	58	57	56	55	54	53	51	49	48
	36	61	61	60	60	59	59	58	57	57	56	55	54	52	51	49	48	46
	35	60	60	59	59	58	58	57	56	56	55	54	53	52	50	49	47	45
	34	59	59	58	58	58	57	56	56	55	54	53	52	51	49	48	46	44
	33	58	57	57	56	56	55	55	54	53	52	51	50	49	48	46	44	43
	32	57	56	56	55	55	54	54	53	52	51	50	49	48	47	45	43	42
	31	56	56	55	55	54	54	53	52	51	51	50	48	47	46	44	43	41
	30	55	55	54	54	53	53	52	51	51	50	49	48	46	45	43	42	40
	29	53	53	53	52	52	51	50	50	49	48	47	46	45	43	42	40	38
	28	52	52	52	51	51	50	50	49	48	47	46	45	44	43	41	39	37
	27	52	51	51	50	50	49	49	48	47	46	45	44	43	42	40	38	37
	26	50	50	49	49	48	48	47	46	46	45	44	43	41	40	38	37	35
	25	49	49	48	48	47	47	46	45	45	44	43	42	40	39	37	36	34
	24	47	47	47	46	46	45	44	44	43	42	41	40	39	37	36	34	32
	23	46	46	46	45	45	44	44	43	42	41	40	39	38	37	35	33	31
	22	45	44	44	44	43	43	42	41	40	40	38	37	36	35	33	32	30
	21	44	44	43	43	42	42	41	40	40	39	38	37	35	34	32	31	29
	20	42	42	41	41	41	40	39	39	38	37	36	35	34	32	31	29	27
	19	41	41	41	40	40	39	39	38	37	36	35	34	33	31	30	28	26
	18	41	40	40	39	39	38	38	37	36	35	34	33	32	31	29	27	26
	17	39	39	38	38	37	37	36	35	34	34	33	31	30	29	27	26	24
	16	37	37	36	36	35	35	34	34	33	32	31	30	29	27	26	24	22
	15	36	36	36	35	35	34	33	33	32	31	30	29	28	26	25	23	21
	14	35	34	34	33	33	32	32	31	30	29	28	27	26	25	23	21	20
	13	34	33	33	33	32	31	31	30	29	28	27	26	25	24	22	21	19
	12	32	32	31	31	30	30	29	28	28	27	26	25	23	22	20	19	17
	11	31	31	30	30	30	29	28	28	27	26	25	24	23	21	20	18	16
	10	29	29	29	28	28	27	27	26	25	24	23	22	21	20	18	16	14
	9	28	27	27	27	26	26	25	24	23	23	21	20	19	18	16	15	13
	8	27	27	26	26	25	25	24	23	23	22	21	20	18	17	15	14	12
	7	25	25	24	24	24	23	22	22	21	20	19	18	17	15	14	12	10
	6	24	23	23	22	22	21	21	20	19	18	17	16	15	14	12	10	9
	5	23	22	22	21	21	20	20	19	18	17	16	15	14	13	11	9	8
	4	21	21	20	20	19	19	18	17	17	16	15	14	12	11	9	8	6
	3	19	19	19	18	18	17	16	16	15	14	13	12	11	9	8	6	4
	2	18	18	18	17	17	16	16	15	14	13	12	11	10	9	7	5	3
	1	17	16	16	16	15	14	14	13	12	11	10	9	8	7	5	4	2
0	15	15	14	14	13	13	12	11	11	10	9	8	6	5	3	2	0	