

The University of the State of New York  
REGENTS HIGH SCHOOL EXAMINATION

**PHYSICAL SETTING**  
**EARTH SCIENCE**

**Wednesday, January 26, 2011 — 9:15 a.m. to 12:15 p.m., only**

This is a test of your knowledge of Earth science. Use that knowledge to answer all questions in this examination. Some questions may require the use of the *2010 Edition Reference Tables for Physical Setting/Earth Science*. The reference tables are supplied separately. Be certain you have a copy of the *2010 Edition* of these reference tables before you begin the examination.

The answers to *all* questions are to be written in your separate answer booklet. Be sure to fill in the heading on the front of your answer booklet.

You are to answer all questions in all parts of this examination according to the directions provided in the examination booklet. All work should be written in pen, except for graphs and drawings, which should be done in pencil. You may use scrap paper to work out the answers to the questions, but be sure to record all your answers in your answer booklet.

When you have completed the examination, you must sign the statement printed on the first page of your answer booklet, indicating that you had no unlawful knowledge of the questions or answers prior to the examination and that you have neither given nor received assistance in answering any of the questions during the examination. Your answer booklet cannot be accepted if you fail to sign this declaration.

Notice . . .

A four-function or scientific calculator and a copy of the *2010 Edition Reference Tables for Physical Setting/Earth Science* must be available for you to use while taking this examination.

The use of any communications device is strictly prohibited when taking this examination. If you use any communications device, no matter how briefly, your examination will be invalidated and no score will be calculated for you.

**DO NOT OPEN THIS EXAMINATION BOOKLET UNTIL THE SIGNAL IS GIVEN.**

**Part A**

**Answer all questions in this part**

*Directions (1–35):* For *each* statement or question, write in your answer booklet the *number* of the word or expression that, of those given, best completes the statement or answers the question. Some questions may require the use of the *2010 Edition Reference Tables for Physical Setting/Earth Science*.

1 If an observer on Earth views *Polaris* on the horizon, the observer is located at the

- (1) equator ( $0^\circ$ )
- (2) North Pole ( $90^\circ$  N)
- (3) Tropic of Cancer ( $23.5^\circ$  N)
- (4) Tropic of Capricorn ( $23.5^\circ$  S)

2 The theory that the universe is expanding is supported by the

- (1) blue shift of light from distant galaxies
- (2) red shift of light from distant galaxies
- (3) nuclear fusion occurring in the Sun
- (4) radioactive decay occurring in the Sun

3 Most scientists believe Earth's Early Archean atmosphere was formed primarily by gases released from

- (1) stream erosion
- (2) chemical weathering
- (3) volcanic eruptions
- (4) plant transpiration

4 During which month does the Sun appear to rise farthest north of due east for an observer in New York State?

- (1) December
- (2) January
- (3) June
- (4) July

5 How many degrees does the Sun appear to move across the sky in four hours?

- (1)  $60^\circ$
- (2)  $45^\circ$
- (3)  $15^\circ$
- (4)  $4^\circ$

6 Which type of land surface will most likely absorb the greatest amount of incoming solar radiation?

- (1) rough, dark-colored surface
- (2) rough, light-colored surface
- (3) smooth, dark-colored surface
- (4) smooth, light-colored surface

7 Which graph best shows the general relationship between altitude and temperature in the troposphere?

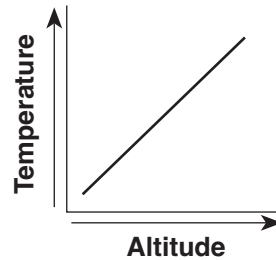

( 1 )

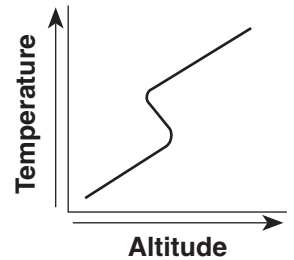

( 3 )

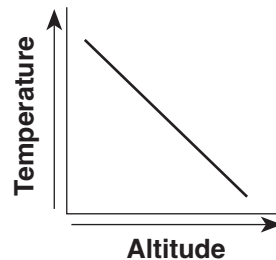

( 2 )

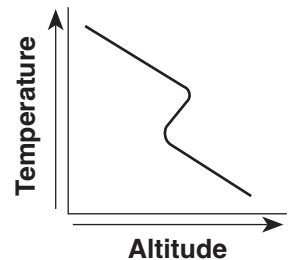

( 4 )

8 Which weather variable is measured by a barometer?

- (1) dewpoint
- (2) wind speed
- (3) air pressure
- (4) visibility

9 During which phase change will the greatest amount of energy be absorbed by 1 gram of water?

- (1) melting
- (2) freezing
- (3) evaporation
- (4) condensation

- 10 The *least* amount of surface water runoff will occur when soil pore spaces are
- (1) saturated and the slope is steep
  - (2) saturated and the slope is gentle
  - (3) unsaturated and the slope is steep
  - (4) unsaturated and the slope is gentle

- 11 Which map best shows the general surface wind pattern in a low-pressure system located over the eastern United States?

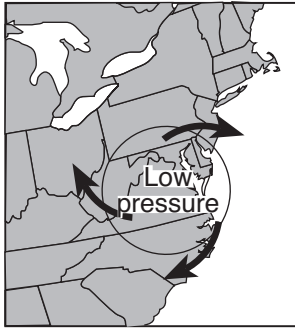

(1)

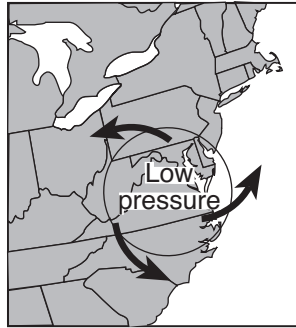

(3)

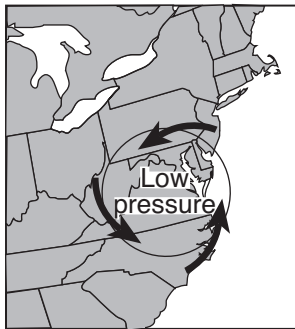

(2)

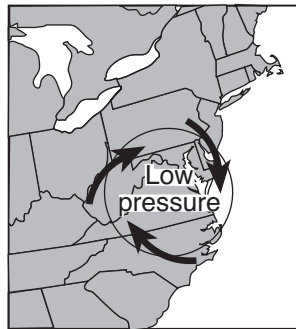

(4)

- 12 Which landscape surface resulted primarily from erosion by glaciers?



(1)



(3)



(2)



(4)

- 13 The formation of soil is primarily the result of
- (1) stream erosion and mass movement
  - (2) stream deposition and runoff
  - (3) precipitation and wind erosion
  - (4) weathering and biological activity

- 14 Sediments found in glacial moraines are best described as

- (1) sorted and layered
- (2) sorted and not layered
- (3) unsorted and layered
- (4) unsorted and not layered

- 15 Old Forge and Watertown, located at nearly the same latitude in New York State, have very different landscapes. Which factor is primarily responsible for these landscape differences?

- (1) average annual temperature
- (2) average annual precipitation
- (3) bedrock structure
- (4) soil characteristics

- 16 The topographic map below shows the location of a stream. Points A and B are locations on Earth's surface.

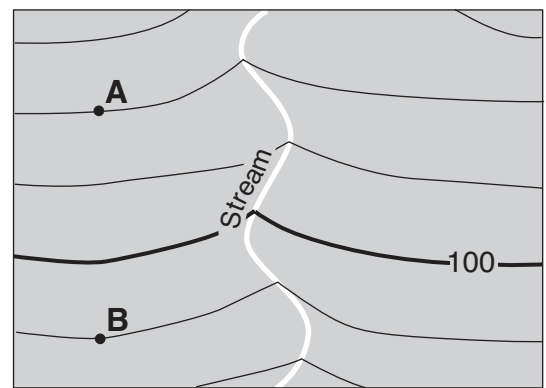

Contour interval = 10 m

0 1 2 3 4 km



What is the gradient between points A and B?

- (1) 1 m/km
- (2) 2 m/km
- (3) 10 m/km
- (4) 20 m/km

17 In which New York State landscape region have fossilized footprints of *Coelophysis* dinosaurs been found in the surface bedrock?

- (1) Allegheny Plateau
- (2) Tug Hill Plateau
- (3) Hudson-Mohawk Lowlands
- (4) Newark Lowlands

18 Which geologic event is inferred to have occurred most recently?

- (1) collision between North America and Africa
- (2) metamorphism of the bedrock of the Hudson Highlands
- (3) formation of the Queenston delta
- (4) initial opening of the Atlantic Ocean

19 The index fossil shown below has been found in New York State sedimentary bedrock.



Which other index fossil could also be found in New York State bedrock of the same age?

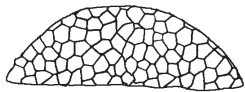

*Lichenaria*

(1)



*Manticoceras*

(3)



*Elliptocephala*

(2)



*Eospirifer*

(4)

20 Which rock is only formed by regional metamorphism?

- (1) slate
- (2) hornfels
- (3) dunite
- (4) marble

21 The Indian-Australian tectonic plate is moving

- (1) away from the Philippine Plate
- (2) away from the Fiji Plate
- (3) toward the Pacific Plate
- (4) toward the Antarctic Plate

22 The inferred temperature at the interface between the stiffer mantle and the asthenosphere is closest to

- (1) 1000°C
- (2) 2500°C
- (3) 4500°C
- (4) 5000°C

23 Which mineral can be found in all samples of rhyolite and andesite?

- (1) pyroxene
- (2) quartz
- (3) biotite
- (4) potassium feldspar

24 A student classified the rock below as sedimentary.



Which observation about the rock best supports this classification?

- (1) The rock is composed of several minerals.
- (2) The rock has a vesicular texture.
- (3) The rock contains fragments of other rocks.
- (4) The rock shows distorted and stretched pebbles.

25 Which material is made mostly of the mineral quartz?

- (1) sulfuric acid
- (2) pencil lead
- (3) plaster of paris
- (4) window glass

26 Which pie graph correctly shows the percentage of elements by volume in Earth's troposphere?

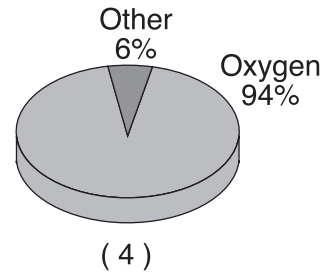
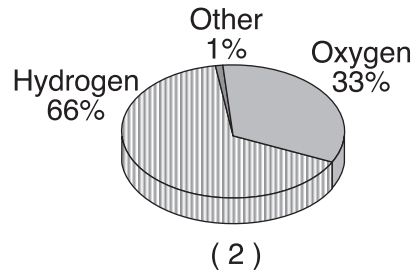
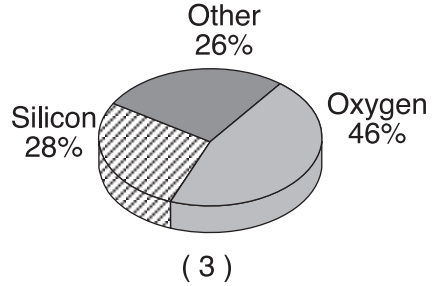
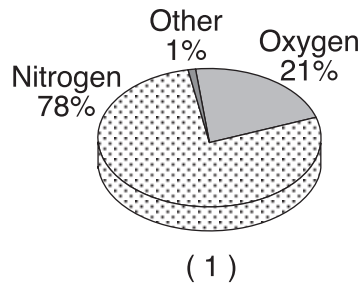

27 The symbols below represent star masses and distances.

- represents a star with a mass the same as the Sun's mass
- represents a star with a mass greater than the Sun's mass
- d represents a certain distance between star centers
- 2d represents twice the distance between star centers

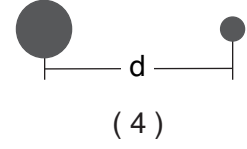
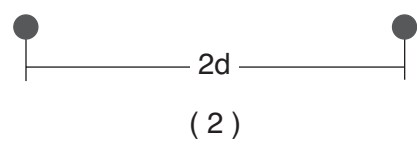
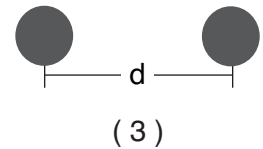
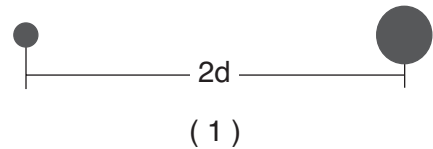

Which diagram shows two stars that have the greatest gravitational force between them?

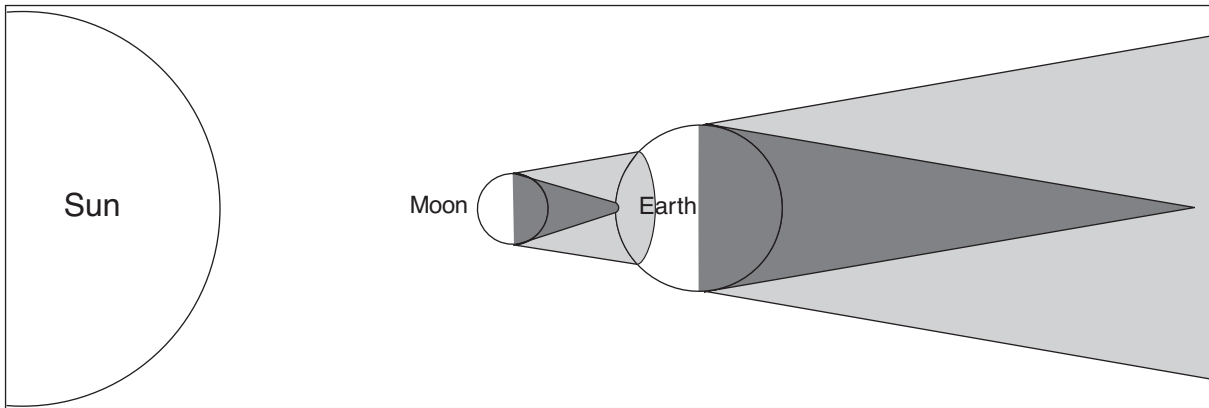

28 The diagram below shows the position of the Sun, the Moon, and Earth during a solar eclipse. The full shadow (umbra) and partial shadow (penumbra) of the Moon and Earth are shown.



(Not drawn to scale)

Key	
	Umbra
	Penumbra

Which diagram best represents the appearance of the Sun and the Moon to an observer located within the umbra of the Moon's shadow on Earth's surface?

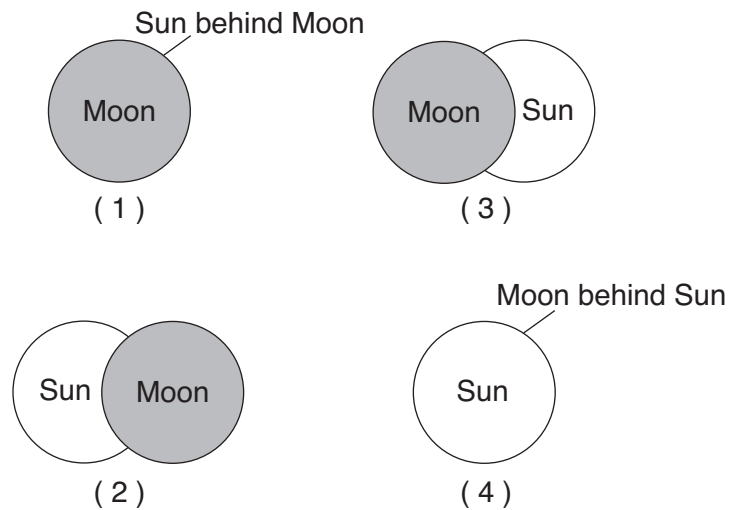

- 29 The map below shows surface air temperatures, in degrees Fahrenheit, reported by weather stations in the north-central United States. Letter X represents an air mass moving in the direction shown by the arrow. A line marks a frontal boundary advancing in a southeasterly direction.

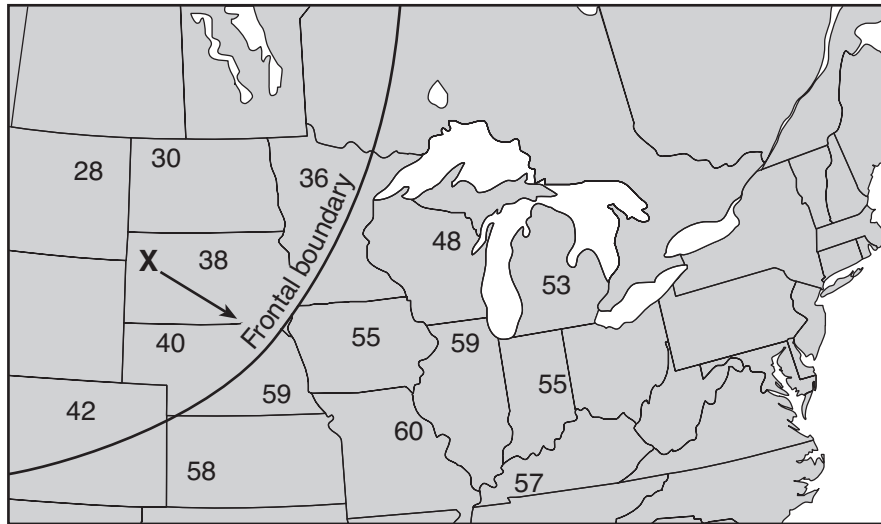

Which weather-map symbols best represent air-mass X and the frontal boundary shown on the map?

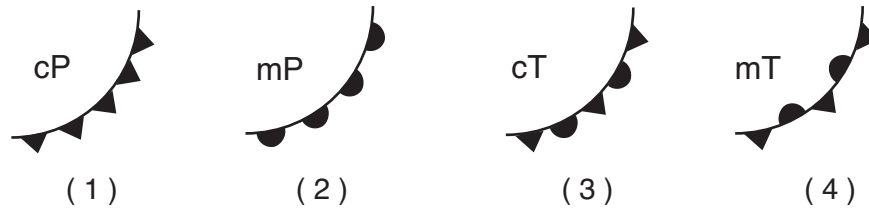

- 30 The block diagram below shows a cross section of a landscape. Letters A, B, C, D, and E represent different rock layers.

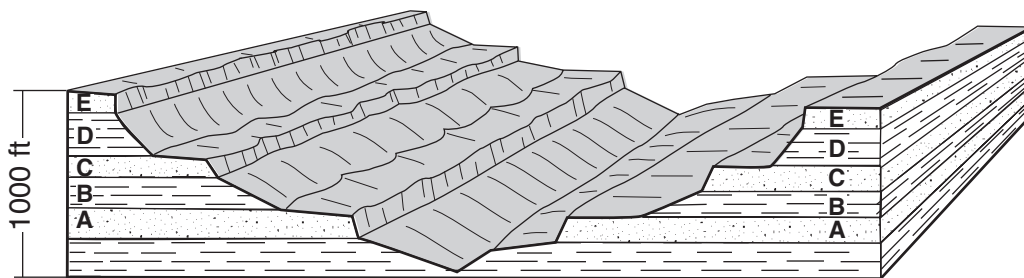

Which rock layers appear to be most resistant to weathering?

- (1) A and B  
 (2) B and D  
 (3) C, D, and E  
 (4) A, C, and E

31 The block diagram below shows a part of the eastern coastline of North America. Points *A*, *B*, and *C* are reference points along the coast.

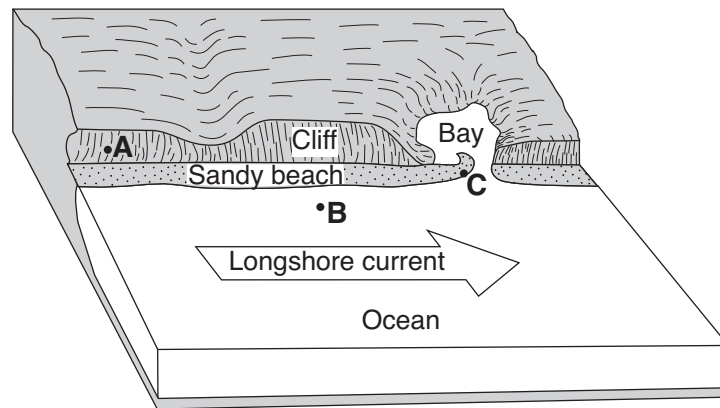

Which list best represents the primary processes occurring along the coastline at points *A*, *B*, and *C*?

- (1) *A* — folding; *B* — subduction; *C* — crosscutting
- (2) *A* — weathering; *B* — erosion; *C* — deposition
- (3) *A* — faulting; *B* — conduction; *C* — mass movement
- (4) *A* — precipitation; *B* — infiltration; *C* — evaporation

32 The block diagram below shows the boundary between two tectonic plates.

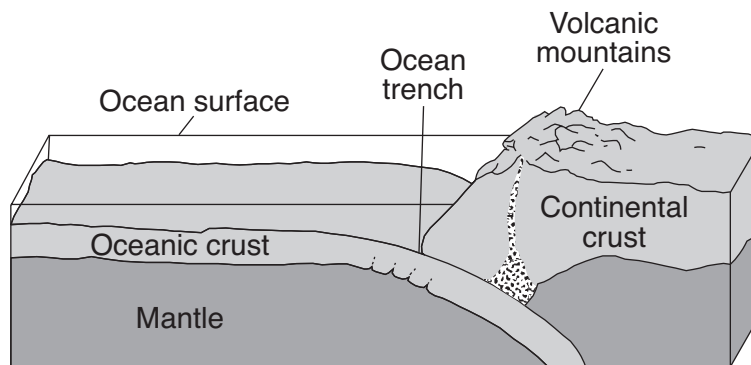

(Not drawn to scale)

Which type of plate boundary is shown?

- (1) divergent
- (2) convergent
- (3) transform
- (4) complex



33 The map below shows the names and ages of different bedrock formations in North America. The bedrock ages are shown in billions of years.

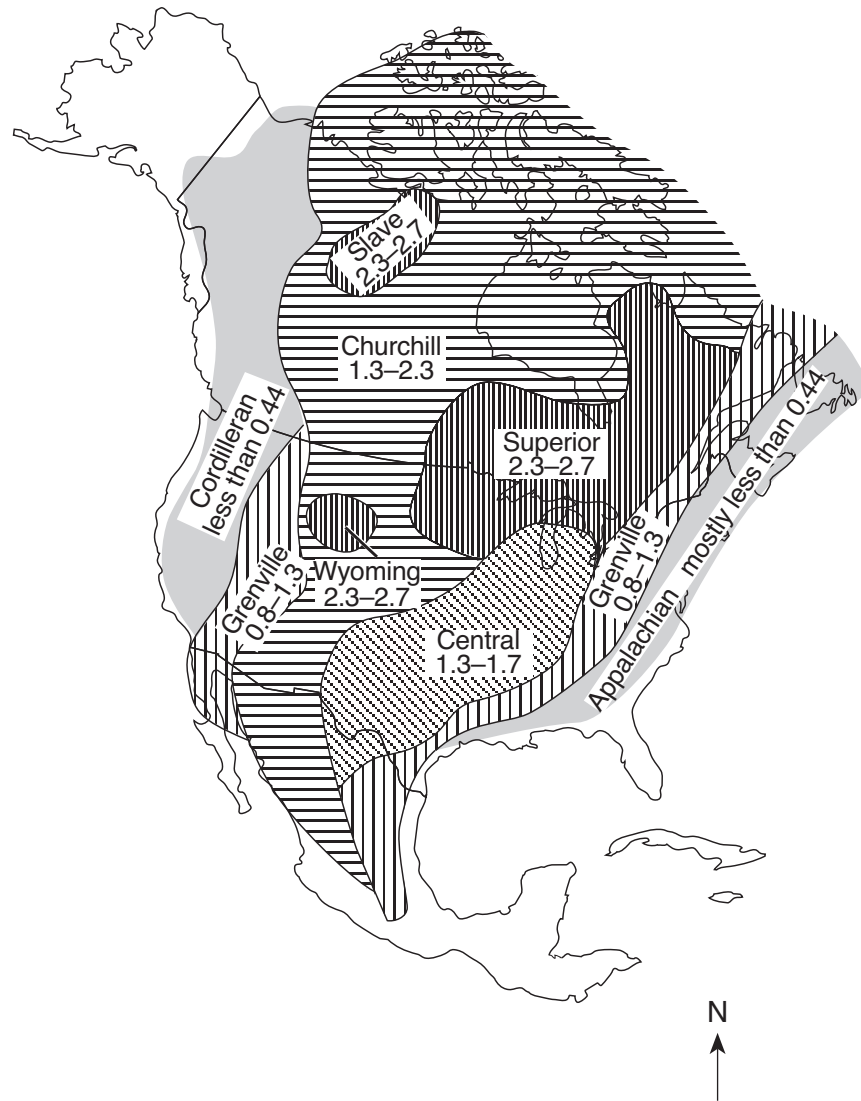

The ages shown on the map suggest that the

- (1) oldest bedrock is located in the Churchill formation
- (2) youngest bedrock is located in the Wyoming formation
- (3) younger bedrock has been added to the east and west coasts of the continent
- (4) age of bedrock increases from west to east across the continent

34 The geologic time line below represents the three most recent geologic eras. The numbers represent events in Earth's history.

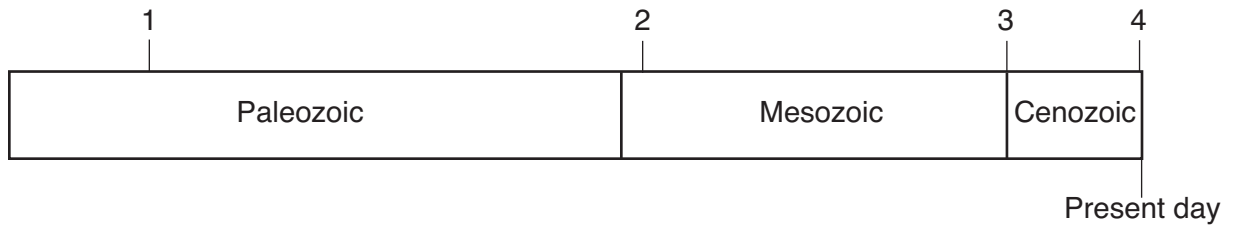

Which number best represents when humans are inferred to have first appeared on Earth?

- (1) 1
- (2) 2
- (3) 3
- (4) 4

35 The diagram below shows magnified views of three stages of mineral crystal formation as molten material gradually cools.

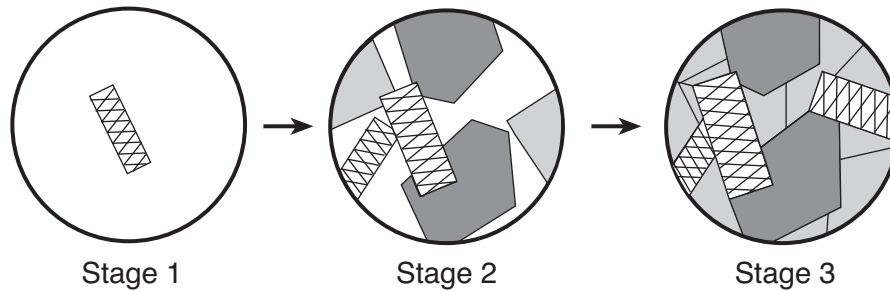

Which rock normally forms when minerals crystallize in these stages?

- (1) shale
- (2) gneiss
- (3) gabbro
- (4) breccia

**Part B-1**

**Answer all questions in this part.**

*Directions (36–50): For each statement or question, write in your answer booklet the number of the word or expression that, of those given, best completes the statement or answers the question. Some questions may require the use of the 2010 Edition Reference Tables for Physical Setting/Earth Science.*

Base your answers to questions 36 and 37 on the diagram below, which shows the results of three different physical tests, A, B, and C, that were performed on a mineral.

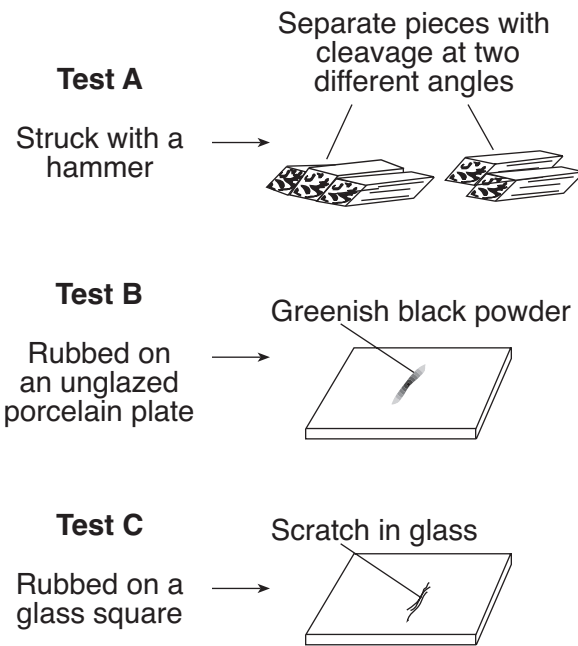

36 Which mineral was tested?

- (1) amphibole
- (2) quartz
- (3) galena
- (4) graphite

37 The luster of this mineral could be determined by

- (1) using an electronic balance
  - (2) using a graduated cylinder
  - (3) observing how light reflects from the surface of the mineral
  - (4) observing what happens when acid is placed on the mineral
-

Base your answers to questions 38 through 42 on the two maps of Australia below. Map I shows Australia's major landscape regions. Letters *A* through *H* represent locations in Australia. Map II shows Australia's general climate regions.

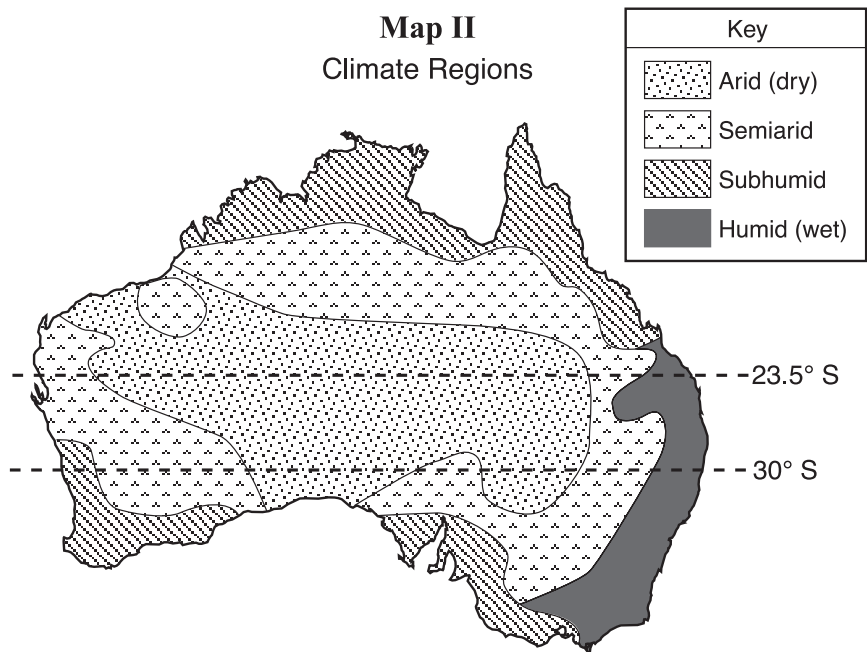
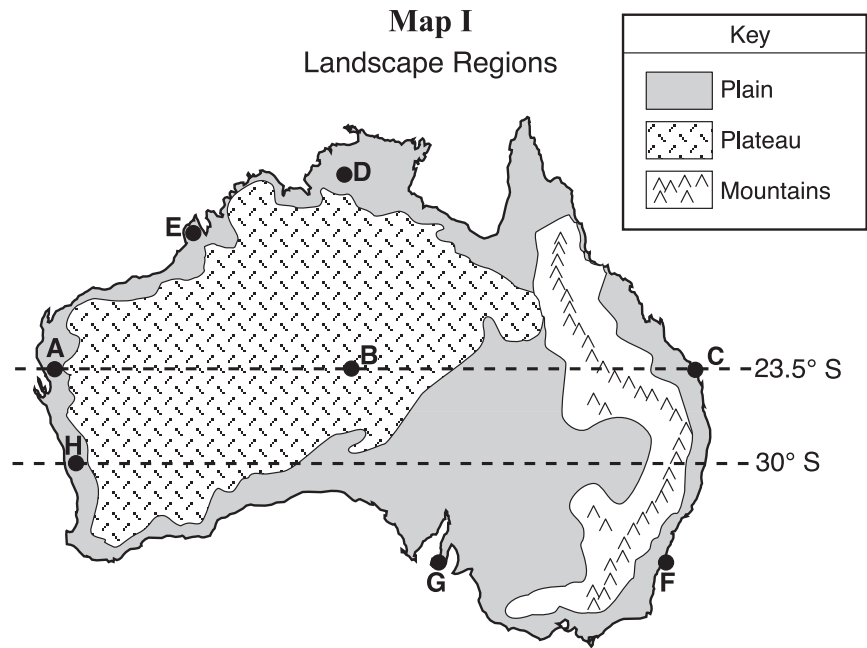

- 38 Location *B* is in a landscape region that has
- (1) high elevations and deformed bedrock
  - (2) high elevations and horizontal bedrock
  - (3) low elevations and deformed bedrock
  - (4) low elevations and horizontal bedrock

39 On which day will the noon Sun be directly overhead at location C?

- (1) March 21
- (2) June 21
- (3) September 23
- (4) December 21

40 The greatest yearly temperature range was most likely recorded at location

- (1) A
- (2) B
- (3) C
- (4) D

41 Which location's climate is most affected by the East Australia Current?

- (1) E
- (2) F
- (3) G
- (4) H

42 Which two locations have the driest climates?

- (1) A and B
  - (2) G and H
  - (3) C and F
  - (4) D and E
- 

Base your answers to questions 43 through 45 on the data table below, which gives information collected at seismic stations W, X, Y, and Z for the same earthquake. Some of the data have been omitted.

**Data Table**

<b>Seismic Station</b>	<b>P-Wave Arrival Time (h:min:s)</b>	<b>S-Wave Arrival Time (h:min:s)</b>	<b>Difference in Arrival Times (h:min:s)</b>	<b>Distance to Epicenter (km)</b>
W	10:50:00	no S-waves arrived		
X	10:42:00	10:46:40		
Y	10:39:20		00:02:40	
Z	10:45:40			6200

43 Which seismic station was farthest from the earthquake epicenter?

- (1) W
- (2) X
- (3) Y
- (4) Z

44 What is the most probable reason for the absence of S-waves at station W?

- (1) S-waves were not generated at the epicenter.
- (2) S-waves cannot travel through liquids.
- (3) Station W was located on solid bedrock.
- (4) Station W was located on an island.

45 At what time did the S-wave arrive at station Y?

- (1) 10:36:40
  - (2) 10:39:20
  - (3) 10:42:00
  - (4) 10:45:20
-

- 46 The diagram below shows an experimental setup to compare water retention and permeability in two columns with equal volumes of spherical plastic beads of different diameters.

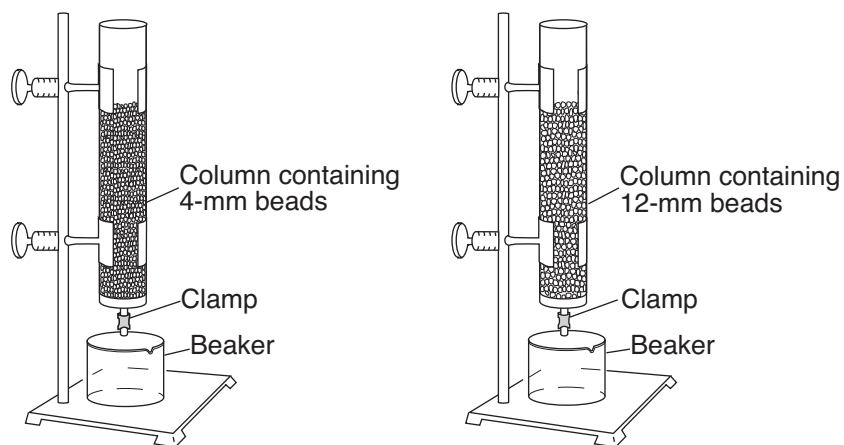

Which statement best describes the water retention and permeability in the two columns of beads?

- (1) The column with 4-mm beads has greater water retention and permeability.
  - (2) The column with 12-mm beads has greater water retention and permeability.
  - (3) The column with 4-mm beads has greater water retention and the column with 12-mm beads has greater permeability.
  - (4) The column with 12-mm beads has greater water retention and the column with 4-mm beads has greater permeability.
- 47 The weather satellite image below shows two large swirl-shaped cloud formations, labeled A and B, over the Pacific Ocean.

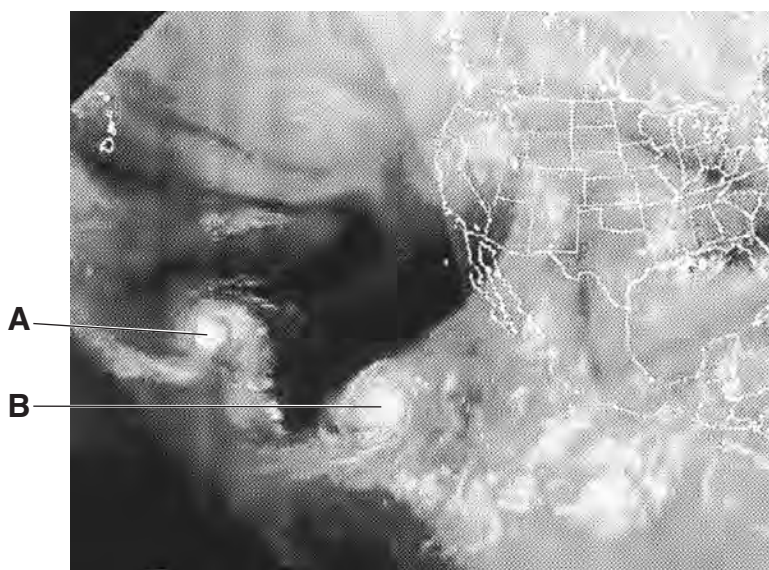

These large swirl-shaped cloud formations most likely represent

- (1) polar air masses
- (2) warm fronts
- (3) tornadoes
- (4) hurricanes

Base your answers to questions 48 through 50 on the map below, which shows the generalized bedrock of a part of western New York State.

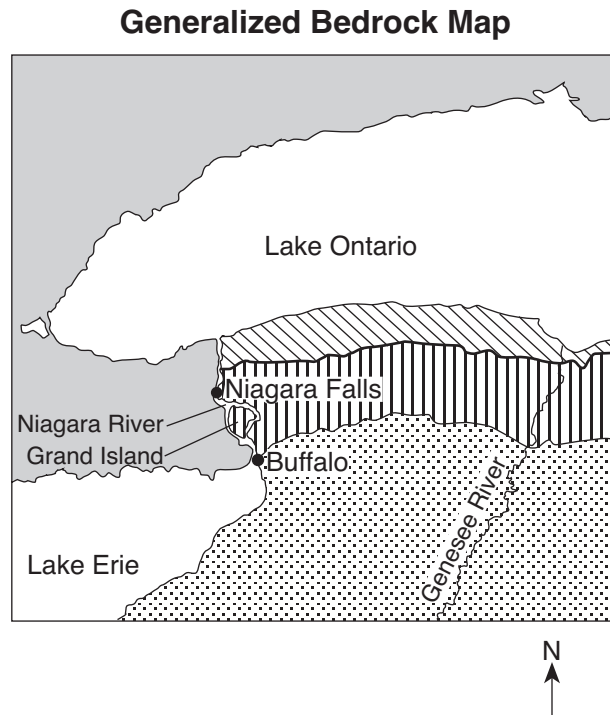

- 48 During which geologic time period was the surface bedrock of Grand Island formed?
- |                |              |
|----------------|--------------|
| (1) Cambrian   | (3) Silurian |
| (2) Ordovician | (4) Devonian |
- 49 Sediments that are transported by the Genesee River generally become
- |                              |                             |
|------------------------------|-----------------------------|
| (1) smaller and rounder      | (3) larger and rounder      |
| (2) smaller and more angular | (4) larger and more angular |
- 50 As the Niagara River enters Lake Ontario, the velocity of the river water
- |   |
|---|
| (1) decreases and larger sediments are deposited first  |
| (2) decreases and smaller sediments are deposited first |
| (3) increases and larger sediments are deposited first  |
| (4) increases and smaller sediments are deposited first |
-

**Part B–2**

**Answer all questions in this part.**

*Directions (51–65):* Record your answers in the spaces provided in your answer booklet. Some questions may require the use of the *2010 Edition Reference Tables for Physical Setting/Earth Science*.

Base your answers to questions 51 and 52 on the diagram below, which shows Earth's orbit around the Sun as viewed from space. Earth is shown at eight different positions labeled A through H. Earth's North Pole, Arctic Circle, and equator have been labeled at position C. The arrows show the direction of orbital motion.

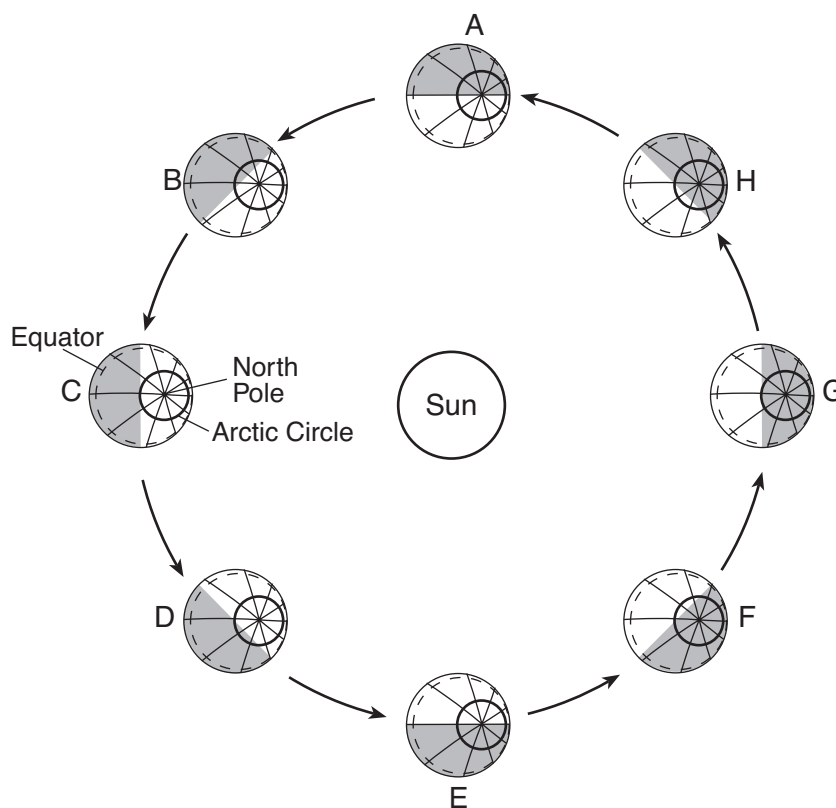

(Not drawn to scale)

- 51 Complete the data table *in your answer booklet* by placing the letter that represents the position of Earth at the start of *each* season in the Northern Hemisphere. [1]
- 52 Approximately how many days does Earth take to move from position A to position C? [1]
-



Base your answers to questions 53 through 57 on the map below, which shows the generalized surface bedrock geology of Iceland, an island located on the Mid-Atlantic Ridge. Points A, B, C, and D are locations on surface bedrock which is igneous in origin. Glaciers cover some surface bedrock.

**Generalized Bedrock Map of Iceland**

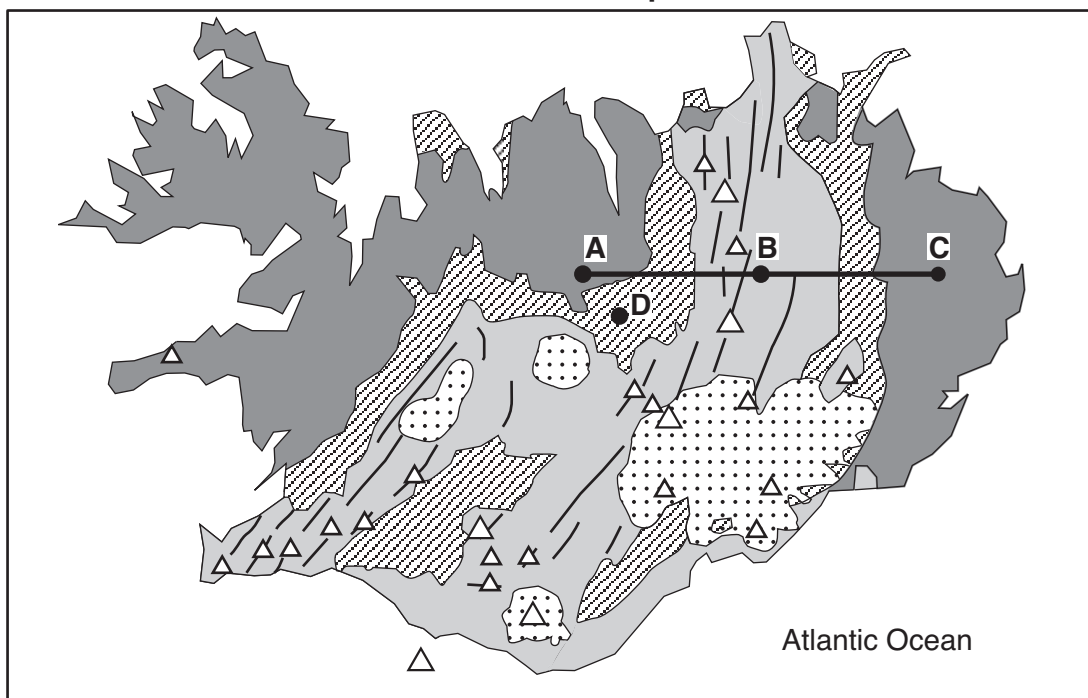

Key	
Glacier	Rock 700,000 to 3,100,000 years old
Rock less than 700,000 years old	Rock more than 3,100,000 years old
Rifting region	Volcano

- 53 State the change in the relative ages of the surface bedrock along the line from A to B to C. [1]
- 54 According to the map, during which geologic era did the surface bedrock at location D form? [1]
- 55 Identify *one* fine-grained, highly mafic, volcanic rock likely found as surface bedrock in Iceland. [1]
- 56 State the names of the *two* crustal plates that are diverging at Iceland. [1]
- 57 In addition to crustal plate divergence, what feature located in the mantle beneath Iceland may be causing Iceland's volcanic activity? [1]
-

Base your answers to questions 58 and 59 on the table below, which shows weather data recorded at Albany, New York.

**Data Table**

Location	Temperature (°F)	Dewpoint (°F)	Cloud Cover (%)	Pressure (mb)	Wind Direction	Wind Speed (knots)
Albany	58	36	25	1017.0	from the west	20

58 Complete the station model *in your answer booklet*, using the proper format to accurately represent these *six* weather conditions. [1]

59 State *one* reason why rain was unlikely at the time the data was collected. Support your answer by using the data. [1]

---

Base your answers to questions 60 and 61 on the passage below.

Average temperatures on Earth are primarily the result of the total amount of insolation absorbed by Earth's surface and atmosphere compared to the amount of long-wave energy radiated back into space. Scientists believe that the addition of greenhouse gases into Earth's atmosphere gradually increases global temperatures.

60 Identify *one* major greenhouse gas that contributes to global warming. [1]

61 Explain how increasing the amount of greenhouse gases in Earth's atmosphere increases global temperatures. [1]

---

Base your answers to questions 62 and 63 on the diagram below, which shows Earth's orbit and the orbit of a comet within our solar system.

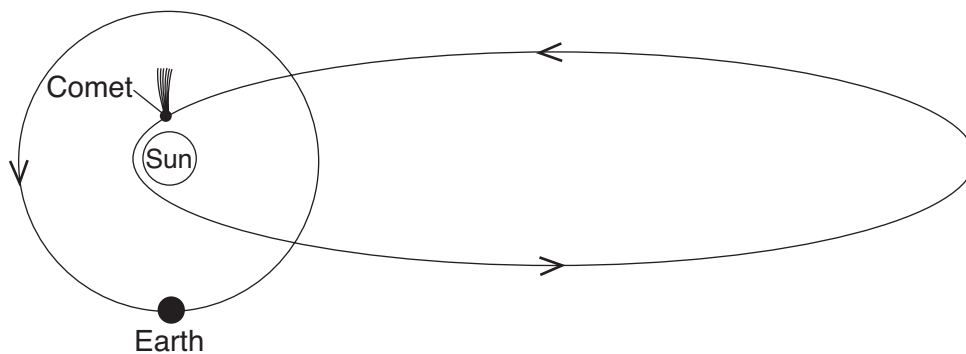

(Not drawn to scale)

62 Explain how this comet's orbit illustrates the heliocentric model of our solar system. [1]

63 Explain why the time required for one revolution of the comet is more than the time required for one revolution of Earth. [1]

---

Base your answers to questions 64 and 65 on the graph below, which shows the distance from the Sun and the period of revolution for four planets in our solar system labeled A, B, C, and D.

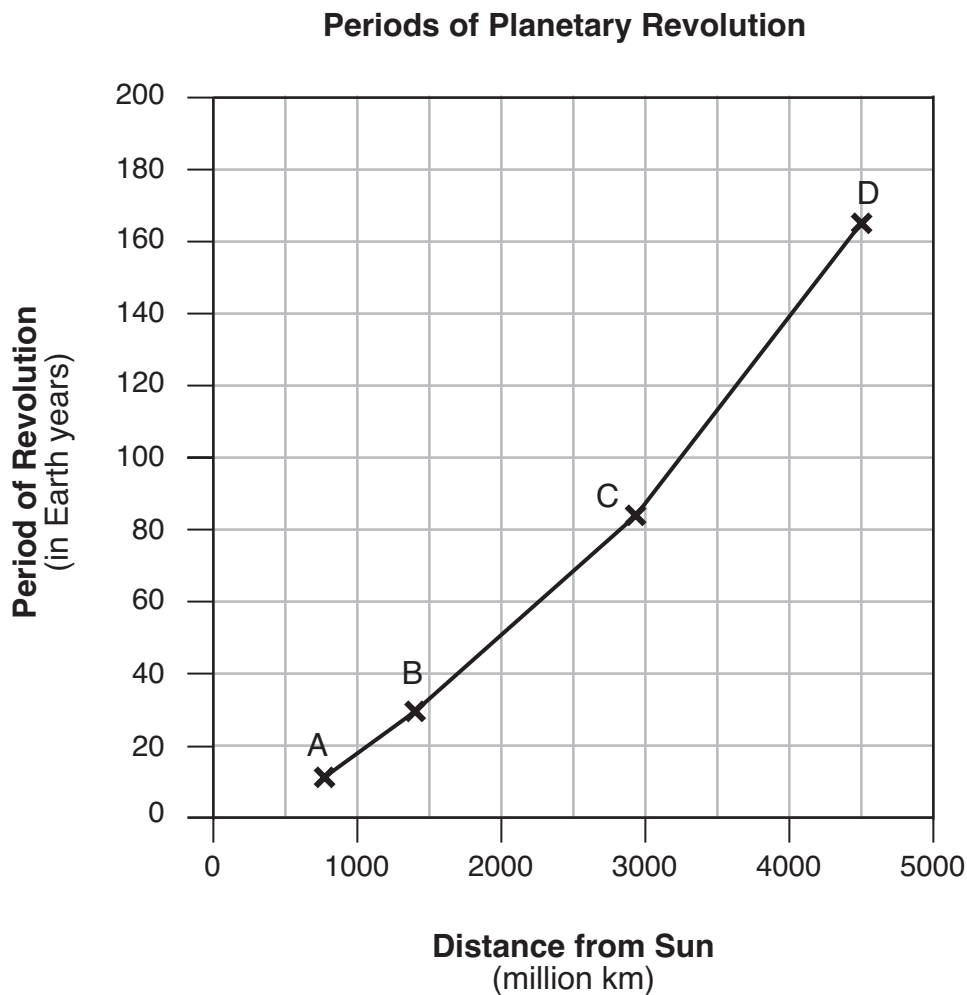

64 State the name of *each* of the planets represented by A, B, C, and D. [1]

65 Describe the relationship between the distance from the Sun and the period of revolution for these four planets. [1]

---

### Part C

#### Answer all questions in this part.

*Directions (66–85):* Record your answers in the spaces provided in your answer booklet. Some questions may require the use of the *2010 Edition Reference Tables for Physical Setting/Earth Science*.

Base your answers to questions 66 through 70 on the cross section below. Letters A through H represent rock units in which overturning has not occurred.

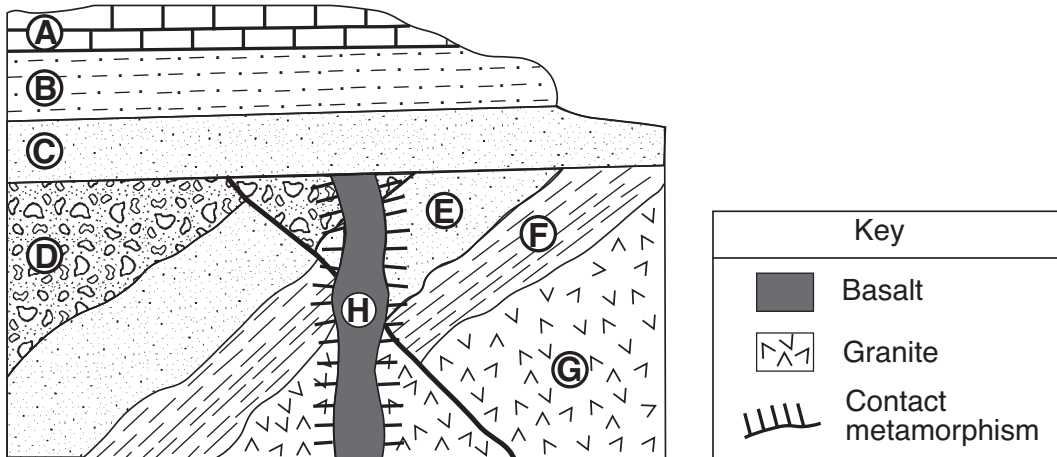

66 Identify *one* metamorphic rock that could have formed at the boundary between rock unit *E* and rock unit *H*. [1]

67 Rock unit *B* contains fossils of *Centroceras* while rock unit *F* contains fossils of *Tetraraptus*. Identify *one* geologic time period when rock unit *D* could have formed. [1]

68 Two inferences about the cross section are listed below.

Inference 1: Rock unit *G* is older than the fault.

Inference 2: Rock unit *A* is younger than rock unit *C*.

Explain how *each* inference is supported by evidence in the cross section. [1]

69 Identify *two* processes that formed rock unit *D* from sediment. [1]

70 State the diameter of a particle normally found in rock unit *B*. [1]

Base your answers to questions 71 through 73 on the passage below.

### Extrasolar Planets

Astronomers have discovered more than 400 planets outside of our solar system. The first extrasolar planet was detected in 1995 orbiting a star known as *51 Pegasi*, which is similar in color and luminosity to our Sun. Astronomers can detect planets by identifying stars that move in response to the gravitational pull of planets revolving around them. Other planets have been discovered by finding stars whose luminosity varies as orbiting planets block outgoing starlight. Nearly all of these discovered planets are thought to be Jovian-like planets similar to Jupiter.

- 71 Other than Jupiter, identify *one* Jovian planet in our solar system. [1]
- 72 Compared to Jupiter, state how Earth's equatorial diameter and density are different. [1]
- 73 State the color and luminosity of *51 Pegasi*. [1]
- 

Base your answers to questions 74 through 76 on the diagram below, which shows one position of the Moon in its orbit around Earth. Letters W, X, Y, and Z are locations on Earth's surface.

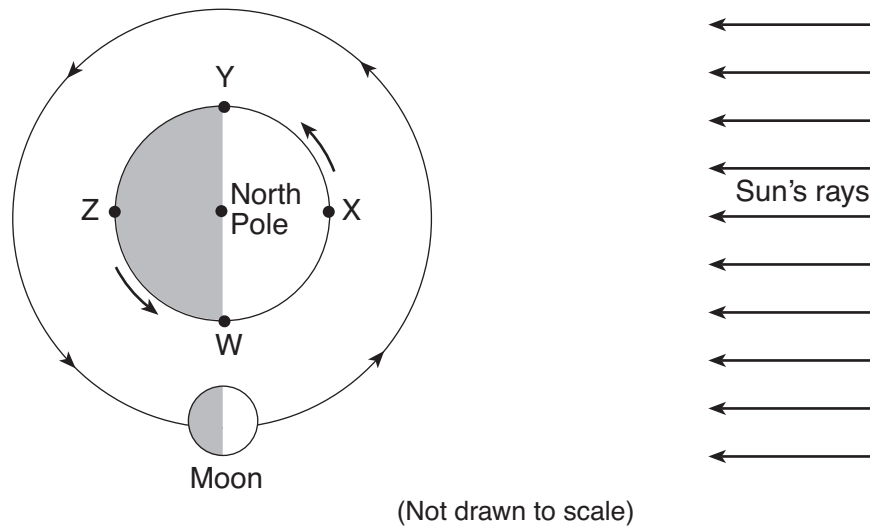

- 74 On the diagram of the Moon *in your answer booklet*, shade the part of the Moon that appears dark to an observer in New York State when the Moon is at the position shown in the diagram. [1]
- 75 *In your answer booklet*, write "high" or "low" to indicate whether a high ocean tide or low ocean tide is occurring at locations W, X, Y, and Z. [1]
- 76 What is the solar time at location Y? Include a.m. or p.m. in your answer. [1]
-

Base your answers to questions 77 through 79 on the map in your answer booklet, which shows the snowfall from the fall of 1976 through the spring of 1977, measured in inches, for most of New York State. The 200-inch snowfall isolines are shown on the map.

- 77 On the map *in your answer booklet*, draw the 100-inch snowfall isoline. Extend the isoline to the edges of New York State. [1]
- 78 The amount of snowfall for Massena is shown on the map. What was the amount of snowfall for Massena? [1]
- 79 Identify *one* factor that contributes to the high snowfall amounts at locations on the eastern side of *both* Lake Erie and Lake Ontario. [1]
- 

Base your answers to questions 80 through 83 on the topographic map in your answer booklet, which shows an area of the Saranac River just west of Plattsburgh, New York. Points *A* and *B* are locations in the river.

- 80 In this region of the Saranac River, the land area that is lower in elevation than 450 feet is a floodplain. On the map *in your answer booklet*, draw a diagonal-line pattern, , to indicate the entire floodplain area. [1]
- 81 Describe how the contour lines shown on the map indicate that the Saranac River flows from point *A* to point *B*. [1]
- 82 Why is erosion of the stream bank more likely at point *A* than at point *B*? [1]
- 83 Identify *one* emergency preparedness activity that people living in the floodplain area can take to protect themselves and their property from possible flooding. [1]
-

Base your answers to questions 84 and 85 on the map and passage below. The map shows isolines of average yearly rainfall, in centimeters, for the Congo River region of Africa.

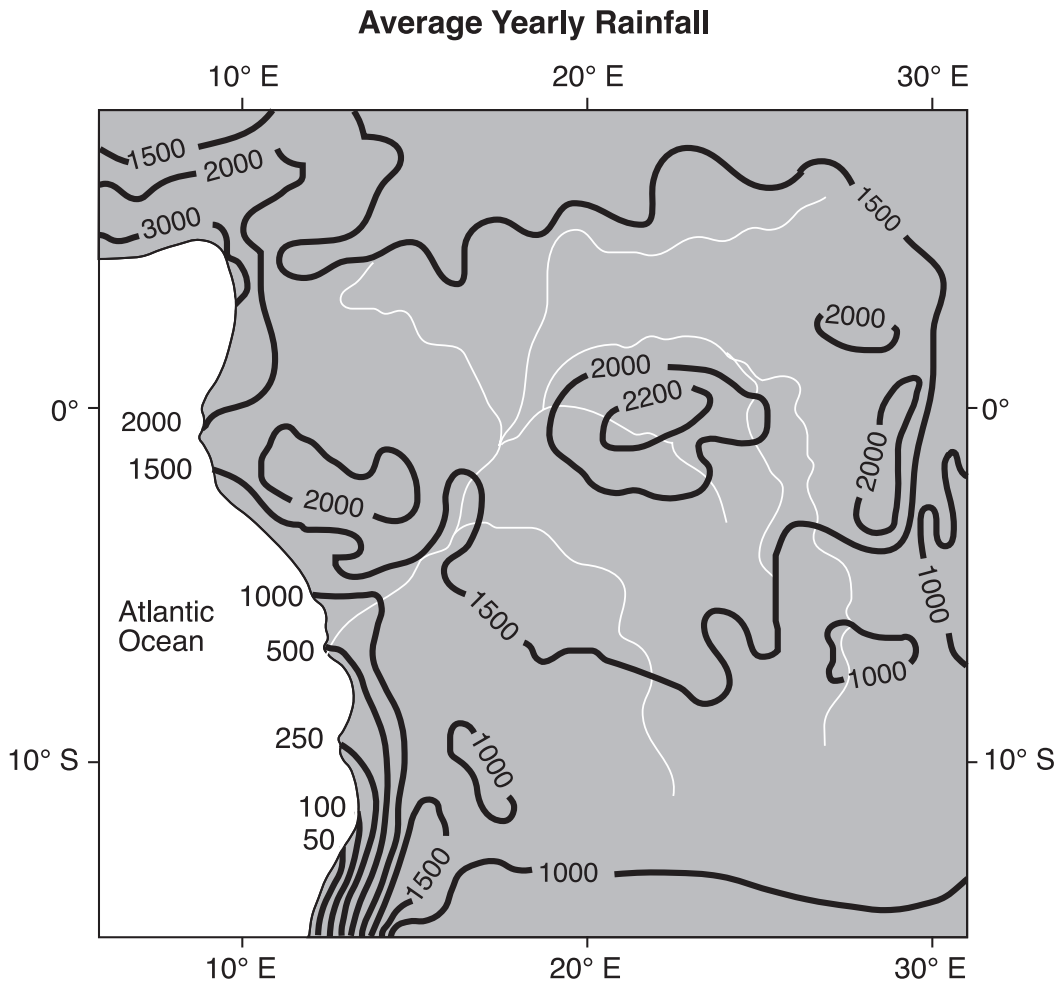

The climate of the Congo River region is mainly influenced by air from two source regions. One air-mass source region is over the Benguela Current along the west coast of Africa. This air mass moves at low altitudes toward the Congo River region. A second air-mass source region is located over the South Equatorial Current along the east coast of Africa. This air mass moves at higher altitudes over the Congo River region.

84 According to the map, what is a possible average yearly rainfall amount received on the equator ( $0^\circ$ ) at  $20^\circ$  E? [1]

85 Explain why air masses that form over the South Equatorial Current move at higher altitudes than air masses that form over the Benguela Current. [1]

---





**PHYSICAL SETTING  
 EARTH SCIENCE**

Wednesday, January 26, 2011 — 9:15 a.m. to 12:15 p.m., only

**ANSWER BOOKLET**

Student ..... Sex:  Male  
 Female  
 Teacher .....  
 School ..... Grade .....

Answer all questions in this examination. Record your answers in this booklet.

**Part A**

- |          |          |          |
|----------|----------|----------|
| 1 .....  | 13 ..... | 25 ..... |
| 2 .....  | 14 ..... | 26 ..... |
| 3 .....  | 15 ..... | 27 ..... |
| 4 .....  | 16 ..... | 28 ..... |
| 5 .....  | 17 ..... | 29 ..... |
| 6 .....  | 18 ..... | 30 ..... |
| 7 .....  | 19 ..... | 31 ..... |
| 8 .....  | 20 ..... | 32 ..... |
| 9 .....  | 21 ..... | 33 ..... |
| 10 ..... | 22 ..... | 34 ..... |
| 11 ..... | 23 ..... | 35 ..... |
| 12 ..... | 24 ..... |          |

**Part A Score**

**Performance Test Score  
 (Maximum Score: 16)**

Part	Maximum Score	Student's Score
A	35	
B-1	15	
B-2	15	
C	20	

**Total Written Test Score  
 (Maximum Raw Score: 85)**

**Final Score  
 (from conversion chart)**

**Raters' Initials:**

Rater 1 ..... Rater 2 .....

**Part B-1**

- |          |          |
|----------|----------|
| 36 ..... | 44 ..... |
| 37 ..... | 45 ..... |
| 38 ..... | 46 ..... |
| 39 ..... | 47 ..... |
| 40 ..... | 48 ..... |
| 41 ..... | 49 ..... |
| 42 ..... | 50 ..... |
| 43 ..... |          |

**Part B-1 Score**

**The declaration below must be signed when you have completed the examination.**

I do hereby affirm, at the close of this examination, that I had no unlawful knowledge of the questions or answers prior to the examination and that I have neither given nor received assistance in answering any of the questions during the examination.

Signature

Part B-2

For Raters  
Only

51

Season	Earth's Position
spring	
summer	
fall	
winter	

51

52 \_\_\_\_\_ d

52

53 \_\_\_\_\_  
\_\_\_\_\_

53

54 \_\_\_\_\_ Era

54

55 \_\_\_\_\_

55

56 \_\_\_\_\_ Plate and \_\_\_\_\_ Plate

56

57 \_\_\_\_\_

57

58

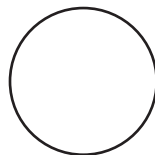

58

59 \_\_\_\_\_  
\_\_\_\_\_

59

**For Raters  
Only**

**60** \_\_\_\_\_

**60**

**61** \_\_\_\_\_  
\_\_\_\_\_

**61**

**62** \_\_\_\_\_  
\_\_\_\_\_

**62**

**63** \_\_\_\_\_  
\_\_\_\_\_

**63**

**64 A:** \_\_\_\_\_

*B:* \_\_\_\_\_

*C:* \_\_\_\_\_

*D:* \_\_\_\_\_

**64**

**65** \_\_\_\_\_  
\_\_\_\_\_

**65**

**Total Score for  
Part B-2**

**Part C**

**For Raters  
Only**

66 \_\_\_\_\_

66

67 \_\_\_\_\_ **Period**

67

68 Evidence for inference 1: \_\_\_\_\_

\_\_\_\_\_

Evidence for inference 2: \_\_\_\_\_

\_\_\_\_\_

68

69 Process 1: \_\_\_\_\_

Process 2: \_\_\_\_\_

69

70 \_\_\_\_\_ **cm**

70

71 \_\_\_\_\_

71

72 Diameter: \_\_\_\_\_

Density: \_\_\_\_\_

72

73 Color: \_\_\_\_\_

Luminosity: \_\_\_\_\_

73

74

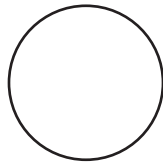

74

For Raters  
Only

75 W: \_\_\_\_\_ tide

X: \_\_\_\_\_ tide

Y: \_\_\_\_\_ tide

Z: \_\_\_\_\_ tide

76 \_\_\_\_\_

77

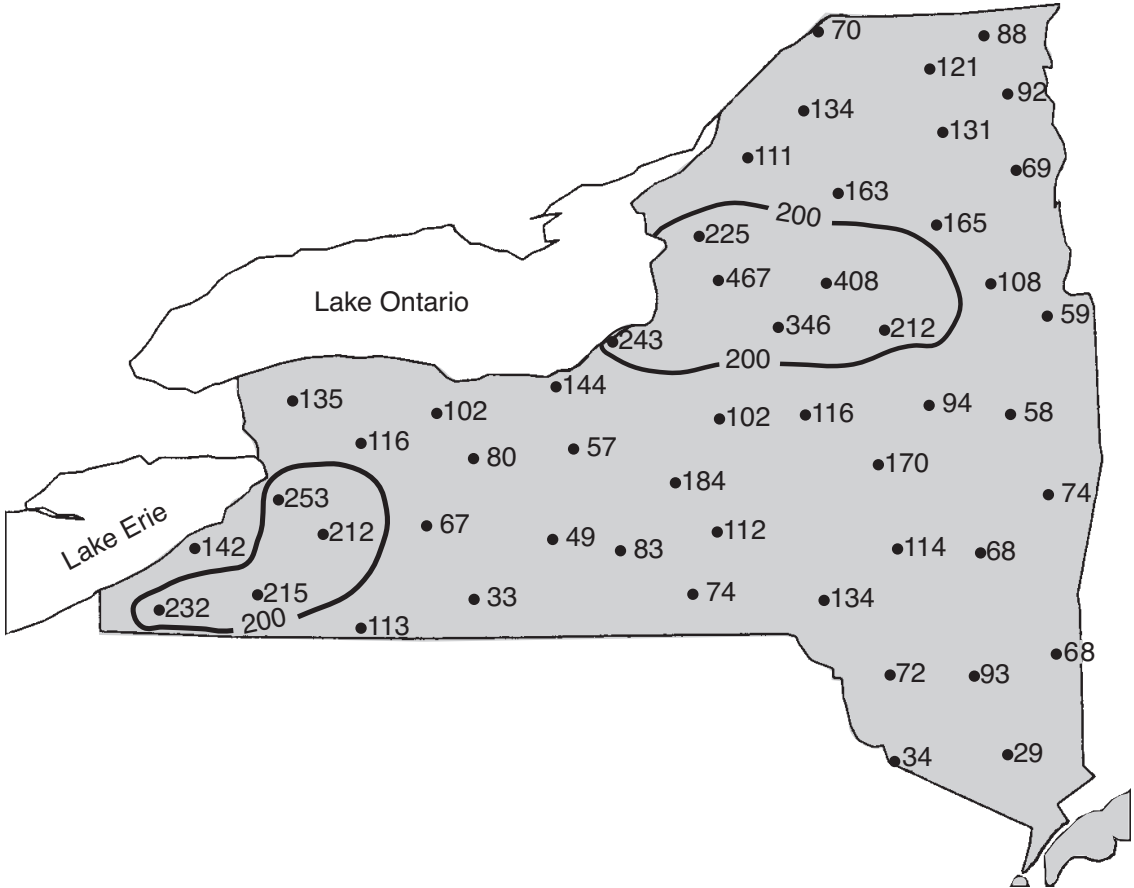

75

76

77

78 \_\_\_\_\_ in



79 \_\_\_\_\_

78

79

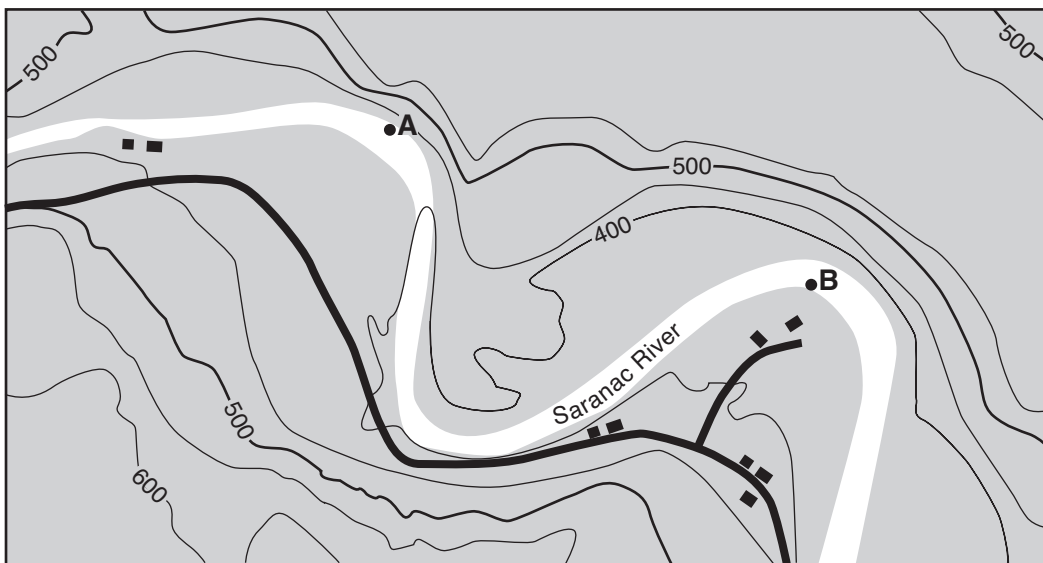
80



Key	
	Road
	Building

Contour interval = 50 ft



80



81

---

---

---

81



82

---

---

---

82



83

---

---

83



**For Raters  
Only**

84

85

**Total Score  
for Part C**

84 \_\_\_\_\_ cm

85 \_\_\_\_\_

\_\_\_\_\_





# FOR TEACHERS ONLY

The University of the State of New York  
REGENTS HIGH SCHOOL EXAMINATION

## PS-ES PHYSICAL SETTING/EARTH SCIENCE

Wednesday, January 26, 2011 — 9:15 a.m. to 12:15 p.m., only

### SCORING KEY AND RATING GUIDE

**Directions to the Teacher:**

Refer to the directions on page 2 before rating student papers.

Updated information regarding the rating of this examination may be posted on the New York State Education Department's web site during the rating period. Check this web site <http://www.p12.nysed.gov/osa/> and select the link "Scoring Information" for any recently posted information regarding this examination. This site should be checked before the rating process for this examination begins and several times throughout the Regents examination period.

**Part A and Part B-1**

Allow 1 credit for each correct response.

Part A			Part B-1	
1 . . . . . <b>1</b> . . . . .	13 . . . . . <b>4</b> . . . . .	25 . . . . . <b>4</b> . . . . .	36 . . . . . <b>1</b> . . . . .	44 . . . . . <b>2</b> . . . . .
2 . . . . . <b>2</b> . . . . .	14 . . . . . <b>4</b> . . . . .	26 . . . . . <b>1</b> . . . . .	37 . . . . . <b>3</b> . . . . .	45 . . . . . <b>3</b> . . . . .
3 . . . . . <b>3</b> . . . . .	15 . . . . . <b>3</b> . . . . .	27 . . . . . <b>3</b> . . . . .	38 . . . . . <b>2</b> . . . . .	46 . . . . . <b>3</b> . . . . .
4 . . . . . <b>3</b> . . . . .	16 . . . . . <b>3</b> . . . . .	28 . . . . . <b>1</b> . . . . .	39 . . . . . <b>4</b> . . . . .	47 . . . . . <b>4</b> . . . . .
5 . . . . . <b>1</b> . . . . .	17 . . . . . <b>4</b> . . . . .	29 . . . . . <b>1</b> . . . . .	40 . . . . . <b>2</b> . . . . .	48 . . . . . <b>3</b> . . . . .
6 . . . . . <b>1</b> . . . . .	18 . . . . . <b>4</b> . . . . .	30 . . . . . <b>4</b> . . . . .	41 . . . . . <b>2</b> . . . . .	49 . . . . . <b>1</b> . . . . .
7 . . . . . <b>2</b> . . . . .	19 . . . . . <b>3</b> . . . . .	31 . . . . . <b>2</b> . . . . .	42 . . . . . <b>1</b> . . . . .	50 . . . . . <b>1</b> . . . . .
8 . . . . . <b>3</b> . . . . .	20 . . . . . <b>1</b> . . . . .	32 . . . . . <b>2</b> . . . . .	43 . . . . . <b>1</b> . . . . .	
9 . . . . . <b>3</b> . . . . .	21 . . . . . <b>3</b> . . . . .	33 . . . . . <b>3</b> . . . . .		
10 . . . . . <b>4</b> . . . . .	22 . . . . . <b>2</b> . . . . .	34 . . . . . <b>4</b> . . . . .		
11 . . . . . <b>2</b> . . . . .	23 . . . . . <b>3</b> . . . . .	35 . . . . . <b>3</b> . . . . .		
12 . . . . . <b>3</b> . . . . .	24 . . . . . <b>3</b> . . . . .			

## Directions to the Teacher

Follow the procedures below for scoring student answer papers for the Physical Setting/Earth Science examination. Additional information about scoring is provided in the publication *Information Booklet for Scoring Regents Examinations in the Sciences*.

Use only *red* ink or *red* pencil in rating Regents papers. Do *not* correct the student's work by making insertions or changes of any kind.

For Part A and Part B–1, indicate by means of a check mark each incorrect or omitted answer. In the box provided at the end of each part, record the number of questions the student answered correctly for that part.

At least two science teachers must participate in the scoring of each student's responses to the Part B–2 and Part C open-ended questions. Each of these teachers should be responsible for scoring a selected number of the open-ended questions on each answer paper. No one teacher is to score all the open-ended questions on a student's answer paper.

Students' responses must be scored strictly according to the Scoring Key and Rating Guide. For open-ended questions, credit may be allowed for responses other than those given in the rating guide if the response is a scientifically accurate answer to the question and demonstrates adequate knowledge as indicated by the examples in the rating guide. In the student's answer booklet, record the number of credits earned for each answer in the box printed to the right of the answer lines or spaces for that question.

Fractional credit is *not* allowed. Only whole-number credit may be given to a response. Units need not be given when the wording of the questions allows such omissions.

Raters should enter the scores earned for Part A, Part B–1, Part B–2, and Part C on the appropriate lines in the box printed on the answer booklet, and then should add these four scores and enter the total in the box labeled "Total Written Test Score." The student's score for the Earth Science Performance Test should be entered in the space provided. Then, the student's raw scores on the performance test and written test should be converted to a scale score by using the conversion chart that will be posted on the Department's web site <http://www.p12.nysed.gov/osa/> on Wednesday, January 26, 2011. The student's scale score should be entered in the labeled box on the student's answer booklet. The scale score is the student's final examination score. On the front of the student's answer booklet, raters must enter their initials on the lines next to "Rater 1" or "Rater 2."

All student answer papers that receive a scale score of 60 through 64 **must** be scored a second time. For the second scoring, a different committee of teachers may score the student's paper or the original committee may score the paper, except that no teacher may score the same open-ended questions that he/she scored in the first rating of the paper. The school principal is responsible for assuring that the student's final examination score is based on a fair, accurate, and reliable scoring of the student's answer paper.

Because scale scores corresponding to raw scores in the conversion chart may change from one examination to another, it is crucial that for each administration, the conversion chart provided for that administration be used to determine the student's final score.

**Part B–2**

**Allow a maximum of 15 credits for this part.**

**51** [1] Allow 1 credit if *all four* letters are correct.

Season	Earth's Position
spring	A
summer	C
fall	E
winter	G

**52** [1] Allow 1 credit for any value from 88 to 94 d.

**53** [1] Allow 1 credit. Acceptable responses include, but are not limited to:

- From point *A* to point *B*, the age of the surface bedrock decreases and from *B* to *C*, the age of the surface bedrock increases.
- The surface bedrock at point *B* is younger than the surface bedrock at point *A* and point *C*.
- gets younger, then older

**54** [1] Allow 1 credit for Cenozoic Era.

**55** [1] Allow 1 credit for basalt *or* vesicular basalt *or* diabase.

**56** [1] Allow 1 credit for North American Plate *and* Eurasian Plate.

**57** [1] Allow 1 credit. Acceptable responses include, but are not limited to:

- hot spot
- rising convection currents
- magma chamber
- rising magma

58 [1] Allow 1 credit if *all six* weather conditions are correctly located and in the proper format.

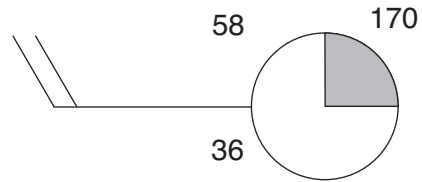

**Note:** Accept *any* quadrant for 1/4 shading to represent sky conditions. Allow credit for two whole feathers on *either* side of the staff.

59 [1] Allow 1 credit. Acceptable responses include, but are not limited to:

- Temperature and dewpoint values are far apart.
- Relative humidity is very low.
- Cloud cover is only 25%.
- Air pressure of 1017.0 mb most likely indicates the presence of a high-pressure system.

60 [1] Allow 1 credit. Acceptable responses include, but are not limited to:

- methane
- water vapor
- carbon dioxide (CO<sub>2</sub>)
- ozone

61 [1] Allow 1 credit. Acceptable responses include, but are not limited to:

- Greenhouse gases absorb the longer wave radiation coming from Earth's surface.
- Greenhouse gases trap the heat given off by Earth.
- Greenhouse gases absorb infrared energy.

62 [1] Allow 1 credit. Acceptable responses include, but are not limited to:

- The comet orbits the Sun.
- The comet doesn't orbit Earth.

63 [1] Allow 1 credit. Acceptable responses include, but are not limited to:

- The comet moves farther from the Sun than Earth's greatest distance from the Sun.
- During most of its orbit the comet is moving slower than Earth.
- The comet's average distance from the Sun is greater.
- The comet has a larger orbit.

**64** [1] Allow 1 credit if *all four* responses are correct.

A: Jupiter

B: Saturn

C: Uranus

D: Neptune

**65** [1] Allow 1 credit. Acceptable responses include, but are not limited to:

— the farther from the Sun, the greater the period of revolution

— Planets closer to the Sun take less time to complete an orbit.

— direct relationship

### Part C

**Allow a maximum of 20 credits for this part.**

- 66** [1] Allow 1 credit for quartzite *or* hornfels.
- 67** [1] Allow 1 credit for Cambrian *or* Ordovician *or* Silurian *or* Devonian Period.
- 68** [1] Allow 1 credit if *both* responses are correct. Acceptable responses include, but are not limited to:  
Evidence for inference 1:  
— A fault is younger than any rock through which it cuts.  
— Rock unit *G* had to be in place before it was cut by the fault.  
— law of crosscutting relationships  
Evidence for inference 2:  
— Rock unit *C* is below rock unit *A*.  
— Younger sedimentary rock is deposited on top of older sedimentary rock.  
— law of superposition
- 69** [1] Allow 1 credit for *two* acceptable responses. Acceptable responses include, but are not limited to:  
— deposition  
— cementation  
— compaction  
— burial
- 70** [1] Allow 1 credit for any value from 0.0004 to 0.006 cm.
- 71** [1] Allow 1 credit for Saturn *or* Uranus *or* Neptune.
- 72** [1] Allow 1 credit if *both* responses are correct. Acceptable responses include, but are not limited to:  
Diameter: smaller  
Density: greater
- 73** [1] Allow 1 credit if *both* responses are correct.  
— Color: yellow  
— Luminosity: 1

74 [1] Allow 1 credit.

**Examples of 1-credit responses:**

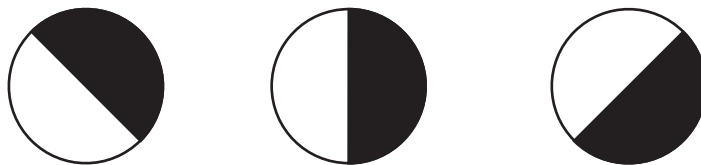

75 [1] Allow 1 credit if *all four* ocean tides are correct.

W: high tide

X: low tide

Y: high tide

Z: low tide

76 [1] Allow 1 credit for 6 p.m.

77 [1] Allow 1 credit for a correctly drawn 100-inch isoline. If the student draws additional isolines, all must be correct to receive credit.

**Example of a 1-credit response:**

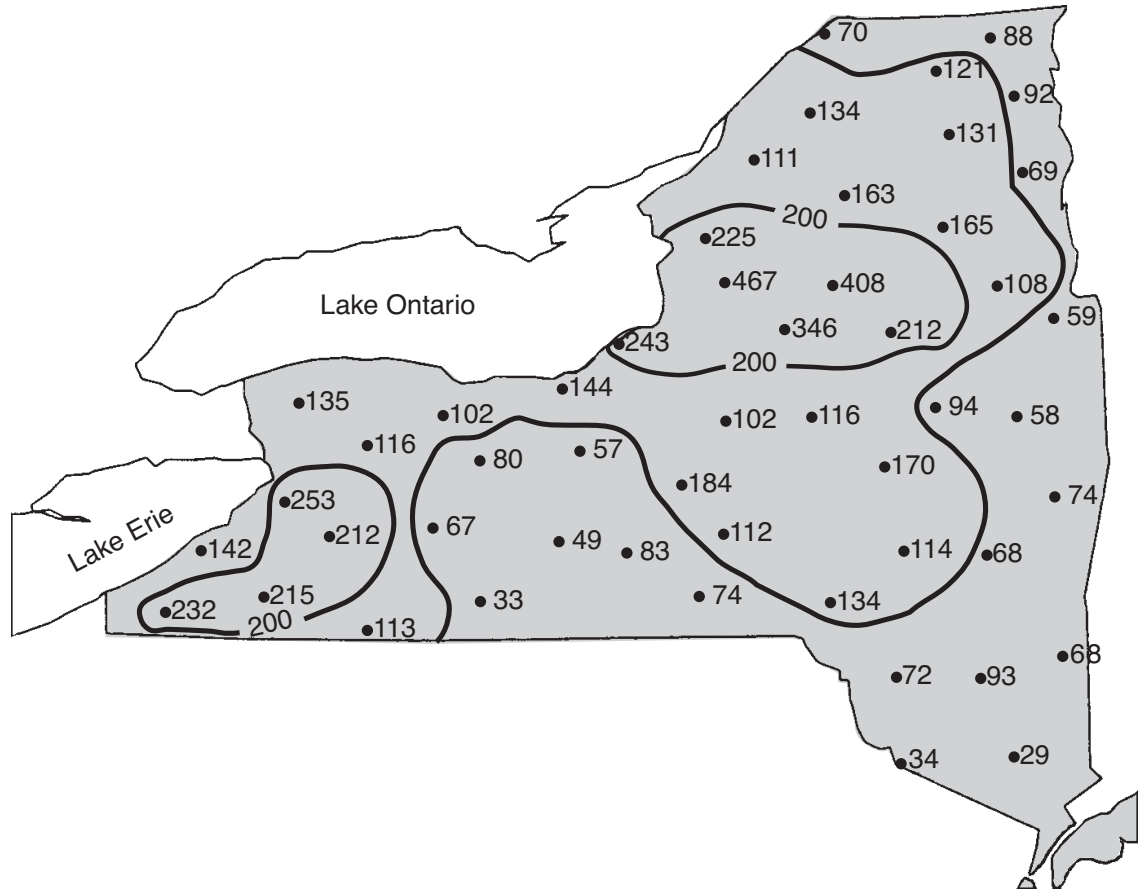

78 [1] Allow 1 credit for 70 in.

79 [1] Allow 1 credit. Acceptable responses include, but are not limited to:

- prevailing wind direction
- higher elevations
- lake-effect snow
- nearness to large bodies of water



80 [1] Allow 1 credit.

**Example of a 1-credit response:**

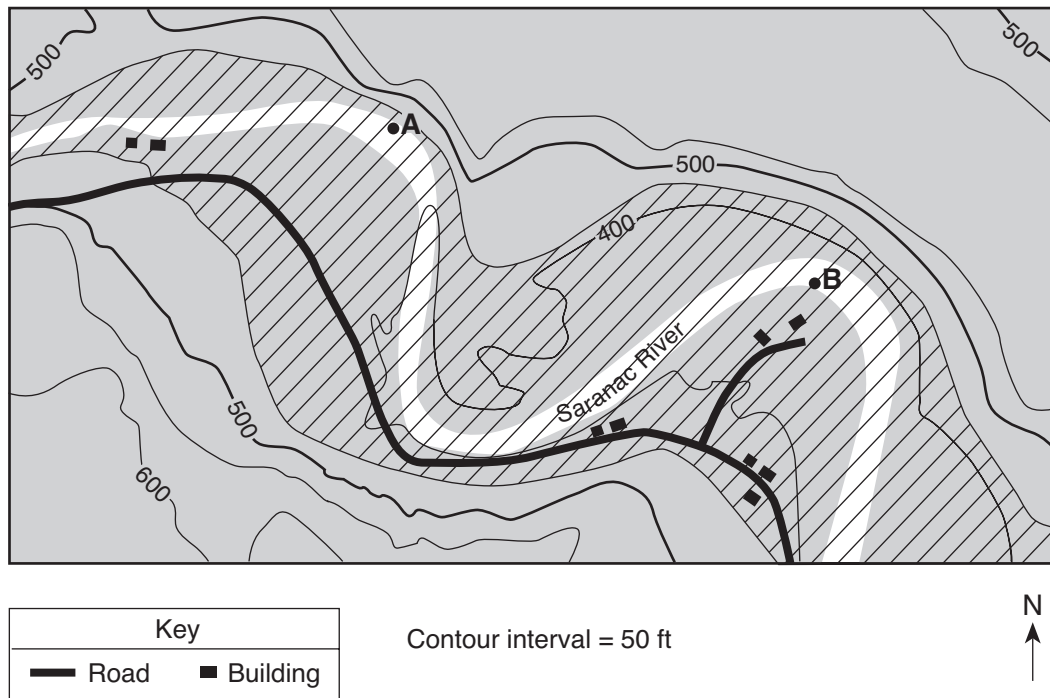

**Note:** Allow credit even if the diagonal line pattern does *not* cover the river.

81 [1] Allow 1 credit. Acceptable responses include, but are not limited to:

- The contour line bends upstream when crossing the river.
- The elevation of the river near the western edge of the map is 450 ft, but is only 400 ft farther east.

82 [1] Allow 1 credit. Acceptable responses include, but are not limited to:

- Erosion is greater on the outside of the meander curve.
- The velocity of the stream is greater at point A.

83 [1] Allow 1 credit. Acceptable responses include, but are not limited to:

- move to higher ground
- build levees
- build flood-control dams upriver
- plan evacuation routes

**84** [1] Allow 1 credit for any value from 2001 cm to 2199 cm.

**85** [1] Allow 1 credit. Acceptable responses include, but are not limited to:

- Warm air from over the South Equatorial Current is less dense.
- The air mass is warmer.
- More moisture is present in the warmer air over the South Equatorial Current.
- The Benguela Current causes the air to be cooler.

## Regents Examination in Physical Setting/Earth Science

January 2011

### Chart for Converting Total Test Raw Scores to Final Examination Scores (Scale Scores)

***The Chart for Determining the Final Examination Score for the January 2011 Regents Examination in Physical Setting/Earth Science will be posted on the Department's web site <http://www.p12.nysed.gov/osa/> on Wednesday, January 26, 2011. Conversion charts provided for previous administrations of the Regents Examination in Physical Setting/Earth Science must NOT be used to determine students' final scores for this administration.***

#### **Submitting Online Teacher Evaluations of the Test to the Department**

Suggestions and feedback from teachers provide an important contribution to the test development process. The Department provides an online evaluation form for State assessments. It contains spaces for teachers to respond to several specific questions and to make suggestions. Instructions for completing the evaluation form are as follows:

1. Go to <http://www.forms2.nysed.gov/emsc/osa/exameval/reexameval.cfm>.
2. Select the test title.
3. Complete the required demographic fields.
4. Complete each evaluation question and provide comments in the space provided.
5. Click the SUBMIT button at the bottom of the page to submit the completed form.

## Map to Core Curriculum

<b>January 2011 Physical Setting/Earth Science</b>			
<b>Question Numbers</b>			
Key Ideas/Performance Indicators	Part A	Part B	Part C
<b>Standard 1</b>			
Math Key Idea 1	16	65	
Math Key Idea 2	7, 16, 26	64, 65	
Math Key Idea 3			
Science Inquiry Key Idea 1		49, 50, 51, 52, 62	66, 67, 68, 69, 79, 82
Science Inquiry Key Idea 2	19	51	
Science Inquiry Key Idea 3			
Engineering Design Key Idea 1			
<b>Standard 2</b>			
Key Idea 1	29	47	
Key Idea 2			
Key Idea 3			83
<b>Standard 6</b>			
Key Idea 1		60	73, 82
Key Idea 2	11, 12, 16, 17, 19, 21, 24, 27, 28, 29, 30, 31, 32, 33, 34, 35	36, 38, 39, 40, 41, 42, 43, 44, 45, 46, 47, 48, 51, 52, 53, 54, 55, 56, 57, 58, 59, 61, 62, 63	66, 67, 68, 69, 70, 71, 72, 73, 74, 75, 76, 77, 79, 80, 81, 82, 84, 85
Key Idea 3			77, 78, 81
Key Idea 4			
Key Idea 5	1, 21, 33	49	76, 82
Key Idea 6		61	
<b>Standard 7</b>			
Key Idea 1			
Key Idea 2			83
<b>Standard 4</b>			
Key Idea 1	1, 2, 3, 4, 5, 9, 10, 17, 18, 19, 27, 28, 33, 34	39, 46, 48, 51, 52, 54, 62, 63, 64, 65	66, 67, 68, 71, 72, 73, 74, 75, 76, 84
Key Idea 2	6, 7, 8, 9, 11, 12, 13, 14, 15, 16, 17, 21, 22, 26, 29, 30, 31, 32	38, 39, 40, 41, 42, 43, 44, 45, 47, 49, 50, 53, 56, 57, 58, 59, 60, 61	76, 77, 78, 79, 80, 81, 82, 83, 84, 85
Key Idea 3	20, 23, 24, 25, 35	36, 37, 55	66, 69, 70
<b>Reference Tables</b>			
ESRT 2010 Edition (Revised)	3, 7, 9, 15, 16, 17, 18, 19, 20, 21, 22, 23, 24, 25, 26, 29, 32, 34, 35	36, 41, 43, 45, 48, 54, 55, 56, 57, 58, 59, 64, 65	66, 67, 69, 70, 71, 72, 73, 79, 85

## Regents Examination in Physical Setting/Earth Science – January 2011

### Chart for Converting Total Test Raw Scores to Final Examination Scores (Scale Scores)

(Not to be used for the Braille Edition)

To determine the student's final score, locate the student's Total Performance Test Score across the top of the chart and the Total Written Test Score down the side of the chart. The point where the two scores intersect is the student's final examination score. For example, a student receiving a Total Performance Test Score of 10 and Total Written Test Score of 71 would receive a final examination score of 90.

		<b>Total Performance Test Score</b>																
		16	15	14	13	12	11	10	9	8	7	6	5	4	3	2	1	0
Total Written Test Score	85	100	99	99	99	98	98	97	96	96	95	94	93	91	90	88	87	85
	84	99	99	98	98	98	97	96	96	95	94	93	92	91	89	88	86	84
	83	99	99	98	98	98	97	96	96	95	94	93	92	91	89	88	86	84
	82	98	98	98	97	97	96	95	95	94	93	92	91	90	88	87	85	83
	81	98	98	98	97	97	96	95	95	94	93	92	91	90	88	87	85	83
	80	97	97	97	96	96	95	95	94	93	92	91	90	89	88	86	84	82
	79	97	96	96	95	95	94	94	93	92	91	90	89	88	87	85	83	82
	78	97	96	96	95	95	94	94	93	92	91	90	89	88	87	85	83	82
	77	96	95	95	95	94	94	93	92	91	91	89	88	87	86	84	83	81
	76	96	95	95	95	94	94	93	92	91	91	89	88	87	86	84	83	81
	75	95	95	94	94	93	93	92	91	91	90	89	88	86	85	83	82	80
	74	94	94	93	93	92	92	91	90	90	89	88	87	86	84	83	81	79
	73	93	93	92	92	92	91	90	90	89	88	87	86	85	83	82	80	78
	72	93	93	92	92	92	91	90	90	89	88	87	86	85	83	82	80	78
	71	92	92	92	91	91	90	90	89	88	87	86	85	84	82	81	79	77
	70	92	91	91	90	90	89	89	88	87	86	85	84	83	82	80	78	77
	69	91	90	90	89	89	88	88	87	86	85	84	83	82	81	79	77	76
	68	91	90	90	89	89	88	88	87	86	85	84	83	82	81	79	77	76
	67	90	90	89	89	88	88	87	86	85	85	84	83	82	81	80	78	75
	66	89	89	88	88	87	87	86	85	85	84	83	82	80	79	77	76	74
65	88	88	87	87	86	86	85	85	84	83	82	81	80	78	77	75	73	
64	87	87	87	86	86	85	84	84	84	83	82	81	80	79	77	76	74	
63	86	86	86	85	85	84	84	84	83	82	81	80	79	78	77	75	73	
62	86	86	86	85	85	84	84	84	83	82	81	80	79	78	77	75	73	
61	86	85	85	84	84	83	83	83	82	81	80	79	78	77	76	74	72	
60	85	84	84	84	83	82	82	81	80	79	78	77	76	75	73	72	70	
59	84	84	83	83	82	82	81	80	80	79	78	77	75	74	72	71	69	
58	83	83	82	82	81	81	80	79	79	78	77	76	74	73	71	70	68	
57	82	82	81	81	81	80	79	79	78	77	76	75	74	72	71	69	67	
56	81	81	81	80	80	79	78	78	77	76	75	74	73	71	70	68	66	
55	80	80	80	79	79	78	78	77	76	75	74	73	72	71	69	67	65	
54	80	79	79	78	78	77	77	76	75	74	73	72	71	70	68	66	65	
53	79	78	78	78	77	77	76	75	74	74	72	71	70	69	67	66	64	
52	78	78	77	77	76	76	75	74	74	73	72	71	69	68	66	65	63	
51	77	77	76	76	75	75	74	73	73	72	71	70	69	67	66	64	62	
50	76	76	75	75	75	74	73	73	72	71	70	69	68	66	65	63	61	
49	75	75	75	74	74	73	73	72	71	70	69	68	67	65	64	62	60	
48	75	74	74	73	73	72	72	71	70	69	68	67	66	65	63	61	60	
47	74	73	73	72	72	71	71	70	69	68	67	66	65	64	62	60	59	

**Final Examination Scores  
January 2011 Examination in Physical Setting/Earth Science – continued**

**Total Performance Test Score**

	<b>16</b>	<b>15</b>	<b>14</b>	<b>13</b>	<b>12</b>	<b>11</b>	<b>10</b>	<b>9</b>	<b>8</b>	<b>7</b>	<b>6</b>	<b>5</b>	<b>4</b>	<b>3</b>	<b>2</b>	<b>1</b>	<b>0</b>
<b>46</b>	73	73	72	72	71	71	70	69	68	68	67	65	64	63	61	60	58
<b>45</b>	72	72	71	71	70	70	69	68	68	67	66	65	63	62	60	59	57
<b>44</b>	71	71	70	70	69	69	68	68	67	66	65	64	63	61	60	58	56
<b>43</b>	70	70	70	69	69	68	67	67	66	65	64	63	62	60	59	57	55
<b>42</b>	69	68	68	67	67	66	66	65	64	63	62	61	60	59	57	55	54
<b>41</b>	68	67	67	67	66	65	65	64	63	62	61	60	59	58	56	55	53
<b>40</b>	67	67	66	66	65	65	64	63	63	62	61	60	58	57	55	54	52
<b>39</b>	66	66	65	65	64	64	63	62	62	61	60	59	57	56	54	53	51
<b>38</b>	65	65	64	64	64	63	62	62	61	60	59	58	57	55	54	52	50
<b>37</b>	63	63	63	62	62	61	61	60	59	58	57	56	55	54	52	50	48
<b>36</b>	63	62	62	61	61	60	60	59	58	57	56	55	54	53	51	49	48
<b>35</b>	62	61	61	61	60	60	59	58	57	57	55	54	53	52	50	49	47
<b>34</b>	61	61	60	60	59	59	58	57	57	56	55	54	52	51	49	48	46
<b>33</b>	59	59	58	58	58	57	56	56	55	54	53	52	51	49	48	46	44
<b>32</b>	58	58	58	57	57	56	56	55	54	53	52	51	50	48	47	45	43
<b>31</b>	58	57	57	56	56	55	55	54	53	52	51	50	49	48	46	44	43
<b>30</b>	56	56	55	55	54	54	53	52	51	51	50	48	47	46	44	43	41
<b>29</b>	55	55	54	54	53	53	52	51	51	50	49	48	46	45	43	42	40
<b>28</b>	54	54	53	53	52	52	51	51	50	49	48	47	46	44	43	41	39
<b>27</b>	52	52	52	51	51	50	50	49	48	47	46	45	44	43	41	39	37
<b>26</b>	52	51	51	50	50	49	49	48	47	46	45	44	43	42	40	38	37
<b>25</b>	51	50	50	50	49	48	48	47	46	45	44	43	42	41	39	38	36
<b>24</b>	49	49	48	48	47	47	46	45	45	44	43	42	40	39	37	36	34
<b>23</b>	48	48	47	47	47	46	45	45	44	43	42	41	40	38	37	35	33
<b>22</b>	46	46	46	45	45	44	44	43	42	41	40	39	38	37	35	33	31
<b>21</b>	46	45	45	44	44	43	43	42	41	40	39	38	37	36	34	32	31
<b>20</b>	44	44	43	43	42	42	41	40	40	39	38	37	35	34	32	31	29
<b>19</b>	43	43	42	42	41	41	40	39	39	38	37	36	35	33	32	30	28
<b>18</b>	41	41	41	40	40	39	39	38	37	36	35	34	33	31	30	28	26
<b>17</b>	41	40	40	39	39	38	38	37	36	35	34	33	32	31	29	27	26
<b>16</b>	39	39	38	38	37	37	36	35	34	34	33	31	30	29	27	26	24
<b>15</b>	37	37	36	36	35	35	34	34	33	32	31	30	29	27	26	24	22
<b>14</b>	36	36	36	35	35	34	33	33	32	31	30	29	28	26	25	23	21
<b>13</b>	35	34	34	33	33	32	32	31	30	29	28	27	26	25	23	21	20
<b>12</b>	33	33	32	32	31	31	30	29	29	28	27	26	24	23	21	20	18
<b>11</b>	32	32	31	31	30	30	29	28	28	27	26	25	23	22	20	19	17
<b>10</b>	30	30	30	29	29	28	27	27	26	25	24	23	22	20	19	17	15
<b>9</b>	29	28	28	27	27	26	26	25	24	23	22	21	20	19	17	15	14
<b>8</b>	28	27	27	27	26	26	25	24	23	23	21	20	19	18	16	15	13
<b>7</b>	26	26	25	25	24	24	23	22	22	21	20	19	18	16	15	13	11
<b>6</b>	24	24	24	23	23	22	22	21	20	19	18	17	16	14	13	11	9
<b>5</b>	23	22	22	21	21	20	20	19	18	17	16	15	14	13	11	9	8
<b>4</b>	22	22	21	21	20	20	19	18	17	17	16	14	13	12	10	9	7
<b>3</b>	20	20	19	19	18	18	17	17	16	15	14	13	12	10	9	7	5
<b>2</b>	18	18	18	17	17	16	16	15	14	13	12	11	10	9	7	5	3
<b>1</b>	17	16	16	16	15	14	14	13	12	11	10	9	8	7	5	4	2
<b>0</b>	15	15	14	14	13	13	12	11	11	10	9	8	6	5	3	2	0